

Airwell

Service Manual

HNDDCISeries

IndoorUnits	OutdoorUnits
AWSI-HND009-N11	AWAU-YND009-H11
AWSI-HND012-N11	AWAU-YND012-H11
AWSI-HND018-N11	AWAU-YND018-H11
AWSI-HND024-N11	AWAU-YND024-H11



REFRIGERANT

R410A

SM HND DCI 4-A.1 GB

HEATPUMP

SEP-2015

CONTENTS

1. Precaution	3
1.1 Safety Precaution.....	3
1.2 Warning.....	3
2. Part Names And Functions	6
2.1 Model Names of Indoor/Outdoor units	6
2.2 Functions of Indoor/Outdoor units.....	6
3. Specification	7
4. Dimension	10
4.1 Indoor Unit	11
4.2 Outdoor Unit.....	13
5. Refrigerant Cycle Diagram	14
6. Wiring Diagram	16
6.1 Indoor Unit	16
6.2 Outdoor Unit.....	19
7. Installation Details	22
7.1 Wrench torque sheet for installation.....	22
7.2 Connecting the cables	22
7.3 Pipe length and the elevation.....	23
7.4 Installation for the first time	24
7.5 Adding the refrigerant after running the system for many years.....	26
7.6 Re-installation while the indoor unit need to be repaired	28
7.7 Re-installation while the outdoor unit need to be repaired	30
8. Operation Characteristics	32
9. Electronic function	33
9.1 Abbreviation	33
9.2 Display function.....	33
9.3 Main Protection	34
9.4 Operation Modes and Functions	36
10. Troubleshooting	Error! Bookmark not defined.
10.1 Indoor Unit Error Display.....	51
10.2 Diagnosis and Solution	52
11. Exploded View	68
11.1 Indoor unit	68
11.2 Outdoor unit	76

1. Precaution

1.1 Safety Precaution

- To prevent injury to the user or other people and property damage, the following instructions must be followed.
- Incorrect operation due to ignoring instruction will cause harm or damage.
- Before service the unit, be sure to read this service manual at first.

1.2 Warning

➤ Installation

- Do not use a defective or underrated circuit breaker. Use this appliance on a dedicated circuit.

There is risk of fire or electric shock.

- For electrical work, contact the dealer, seller, a qualified electrician, or an authorized service center.

Do not disassemble or repair the product, there is risk of fire or electric shock.

- Always ground the product.

There is risk of fire or electric shock.

- Install the panel and the cover of control box securely.

There is risk of fire or electric shock.

- Always install a dedicated circuit and breaker.

Improper wiring or installation may cause electric shock.

- Use the correctly rated breaker of fuse.

There is risk of fire or electric shock.

- Do not modify or extend the power cable.

There is risk of fire or electric shock.

- Do not install, remove, or reinstall the unit by yourself(customer).

There is risk of fire, electric shock, explosion, or injury.

- Be caution when unpacking and installing the product.

Sharp edges could cause injury, be especially careful of the case edges and the fins on the condenser and evaporator.

- For installation, always contact the dealer or an authorized service center.

- Do not install the product on a defective installation stand.

- Be sure the installation area does not deteriorate with age.

If the base collapses, the air conditioner could fall with it, causing property damage, product failure, and personal injury.

- Do not let the air conditioner run for a long time when the humidity is very high and a door or a window is left open.

- Take care to ensure that power cable could not be pulled out or damaged during operation.

There is risk of fire or electric shock.

- Do not place anything on the power cable.

There is risk of fire or electric shock.

- Do not plug or unplug the power supply plug during operation.

There is risk of fire or electric shock.

- Do not touch (operation) the product with wet hands.

- Do not place a heater or other appliance near the power cable.

There is risk of fire and electric shock.

- Do not allow water to run into electrical parts.

It may cause fire, failure of the product, or electric shock.

- Do not store or use flammable gas or combustible near the product.

There is risk of fire or failure of product.

- Do not use the product in a tightly closed space for a long time.

Oxygen deficiency could occur.

- When flammable gas leaks, turn off the gas and open a window for ventilation before

turn the product on.

■ **If strange sounds or smoke comes from product, turn the breaker off or disconnect the power supply cable.**

There is risk of electric shock or fire.

■ **Stop operation and close the window in storm or hurricane. If possible, remove the product from the window before the hurricane arrives.**

There is risk of property damage, failure of product, or electric shock.

■ **Do not open the inlet grill of the product during operation. (Do not touch the electrostatic filter, if the unit is so equipped.)**

There is risk of physical injury, electric shock, or product failure.

■ **When the product is soaked, contact an authorized service center.**

There is risk of fire or electric shock.

■ **Be caution that water could not enter the product.**

There is risk of fire, electric shock, or product damage.

■ **Ventilate the product from time to time when operating it together with a stove etc.**

There is risk of fire or electric shock.

■ **Turn the main power off when cleaning or maintaining the product.**

There is risk of electric shock.

■ **When the product is not be used for a long time, disconnect the power supply plug or turn off the breaker.**

There is risk of product damage or failure, or unintended operation.

■ **Take care to ensure that nobody could step on or fall onto the outdoor unit.**

This could result in personal injury and product damage.

➤ CAUTION

■ **Always check for gas (refrigerant) leakage after installation or repair of product.**

Low refrigerant levels may cause failure of product.

■ **Install the drain hose to ensure that water is drained away properly.**

A bad connection may cause water leakage.

■ **Keep level even when installing the product.**

It can avoid vibration of water leakage.

■ **Do not install the product where the noise or hot air from the outdoor unit could damage the neighborhoods.**

It may cause a problem for your neighbors.

■ **Use two or more people to lift and transport the product.**

■ **Do not install the product where it will be exposed to sea wind (salt spray) directly.**

It may cause corrosion on the product. Corrosion, particularly on the condenser and evaporator fins, could cause product malfunction or inefficient operation.

➤ Operational

■ **Do not expose the skin directly to cool air for long time. (Do not sit in the draft).**

■ **Do not use the product for special purposes, such as preserving foods, works of art etc.**

It is a consumer air conditioner, not a precision refrigerant system.

There is risk of damage or loss of property.

■ **Do not block the inlet or outlet of air flow.**

■ **Use a soft cloth to clean. Do not use harsh detergents, solvents, etc.**

There is risk of fire, electric shock, or damage to the plastic parts of the product.

■ **Do not touch the metal parts of the product when removing the air filter. They are very sharp.**

■ **Do not step on or put anything on the product. (outdoor units)**

■ **Always insert the filter securely. Clean the filter every two weeks or more often if necessary.**

A dirty filter reduces the efficiency of the air conditioner and could cause product malfunction or damage.

■ **Do not insert hands or other objects through air inlet or outlet while the product is operated.**

■ **Do not drink the water drained from the product.**

PRECAUTION

- **Use a firm stool or ladder when cleaning or maintaining the product.**
Be careful and avoid personal injury.
- **Replace the all batteries in the remote control with new ones of the same type. Do not mix old and new batteries or different types of batteries.**
There is risk of fire or explosion.
- **Do not recharge or disassemble the batteries. Do not dispose of batteries in a fire.**
They may burn or explode.
- **If the liquid from the batteries gets onto your skin or clothes, wash it well with clean water. Do not use the remote if the batteries have leaked.**

2. Model Names and Functions

2.1 Model Names of Indoor/Outdoor units

Series	Capacity	Indoor units	Outdoor units
Inverter	9k	AWSI-HND009-N11	AWAU-YND009-H11
	12k	AWSI-HND012-N11	AWAU-YND012-H11
	18k	AWSI-HND018-N11	AWAU-YND018-H11
	24k	AWSI-HND024-N11	AWAU-YND024-H11

2.2 Functions of Indoor/Outdoor units

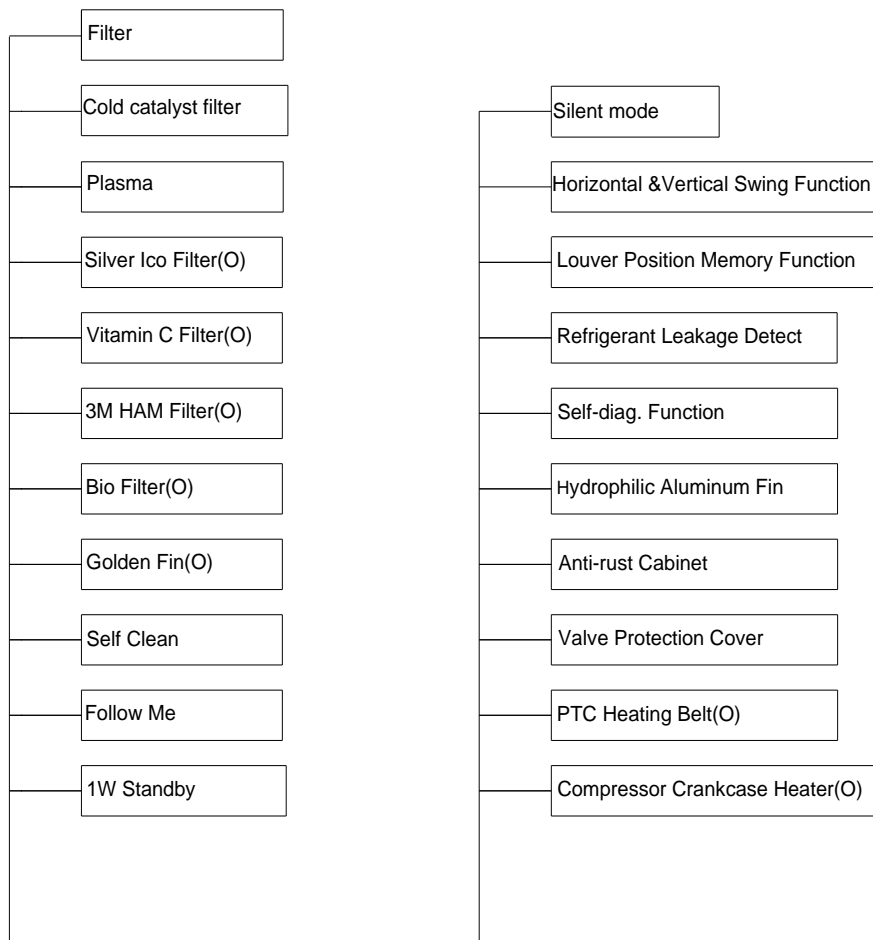

O: optional function

3. Specification

Model Indoor Unit		AWSI-HND009-N11		
Model Outdoor Unit		AWAU-YND009-H11		
Installation Method of Pipe		Flared		
Characteristics	Units	Cooling	Heating	
			Average	
Capacity ⁽¹⁾	kW	2.7(1.0~3.3)	2.78(1.0~3.5)	
Pdesign	kW	2.7	2.8	
SEER /SCOP ⁽²⁾	W/W	6.8	3.9	
Energy efficiency class		A++	A	
Annual energy consumption	kWh	139	1005	
Tbiv	°C	N/A	-10	
Tol	°C	N/A	-15	
Power supply	V/Ph/Hz	220-240V/Single/50Hz		
Circuit breaker rating	A	10		
INDOOR	Fan type & quantity		Cross flow fan x1	
	Fan speeds	H/M/L/VL	RPM	1000/900/800/500
	Air flow ⁽³⁾	H/M/L/VL	m3/hr	500/460/350/300
	External static pressure	Min-Max	Pa	0
	Sound power level ⁽⁴⁾	H/M/L	dB(A)	53
	Sound pressure level ⁽⁵⁾	H/M/L/VL	dB(A)	38/34/28/22
	Moisture removal		l/hr	1.0
	Condensate drain tube I.D		mm	16
	Dimensions	WxHxD	mm	750 x280x198
	Weight		kg	8
	Package dimensions	LxWxH	mm	830 x355x270
	Packaged weight		kg	10.1
	Stacking height		units	8
	OUTDOOR	Refrigerant control		EEV
Compressor type, model		Rotary DC Inverter		
Fan type & quantity		Axial x 1		
Fan speeds		H/L	RPM	800
Air flow		H/L	m3/hr	1800
Sound power level ⁽⁴⁾		H/L	dB(A)	60
Sound pressure level ⁽⁵⁾		H/L	dB(A)	51
Dimensions		WxHxD	mm	760 x590x285
Weight			kg	32.8
Package dimensions		LxWxH	mm	887x355x645
Packaged weight			kg	35.2
Stacking height			units	4
Refrigerant type			R410A	
Refrigerant charge (standard connecting tubing length)		kg(5m)	1.1	
Additional charge per 1 meter		gr / 1m	15	
Connections between units	Liquid line	In.(mm)	1/4"(6.35)	
	Suction line	In.(mm)	3/8"(9.52)	
	Max.tubing length	m.	20	
	Max.height difference	m.	8	
Operation control type			Remote control	
Heating elements		kW		
Others				

Model Indoor Unit		AWSI-HND012-N11		
Model Outdoor Unit		AWAU-YND012-H11		
Installation Method of Pipe		Flared		
Characteristics	Units	Cooling	Heating	
			Average	
Capacity ⁽¹⁾	kW	3.5(1.2~3.8)	3.7(1.2~4.0)	
P _{design}	kW	3.5	3.6	
SEER /SCOP ⁽²⁾	W/W	6.8	3.9	
Energy efficiency class		A++	A	
Annual energy consumption	kWh	180	1292	
T _{biv}	°C	N/A	-7	
T _{ol}	°C	N/A	-15	
Power supply	V/Ph/Hz	220-240V/Single/50Hz		
Circuit breaker rating	A	10		
INDOOR	Fan type & quantity		Cross flow fan x1	
	Fan speeds	H/M/L/VL	RPM	1000/900/800/450
	Air flow ⁽³⁾	H/M/L/VL	m ³ /hr	580/490/380/330
	External static pressure	Min-Max	Pa	0
	Sound power level ⁽⁴⁾	H/M/L	dB(A)	57
	Sound pressure level ⁽⁵⁾	H/M/L/VL	dB(A)	39/35/28/23
	Moisture removal		l/hr	1.3
	Condensate drain tube I.D		mm	16
	Dimensions	WxHxD	mm	835 x280x198
	Weight		kg	9
	Package dimensions	LxWxH	mm	910 x355x270
	Packaged weight		kg	14
	Stacking height		units	8
	OUTDOOR	Refrigerant control		EEV
Compressor type, model		Rotary DC Inverter		
Fan type & quantity		Axial x 1		
Fan speeds		H/L	RPM	800
Air flow		H/L	m ³ /hr	1800
Sound power level ⁽⁴⁾		H/L	dB(A)	62
Sound pressure level ⁽⁵⁾		H/L	dB(A)	52
Dimensions		WxHxD	mm	760 x590x285
Weight			kg	32.9
Package dimensions		LxWxH	mm	887x355x645
Packaged weight			kg	35.2
Stacking height			units	4
Refrigerant type			R410A	
Refrigerant charge (standard connecting tubing length)		kg(5m)	1.1	
Additional charge per 1 meter		gr / 1m	15	
Connections between units		Liquid line	In.(mm)	1/4"(6.35)
		Suction line	In.(mm)	3/8"(9.52)
	Max.tubing length	m.	20	
	Max.height difference	m.	8	
Operation control type			Remote control	
Heating elements		kW		
Others				

SPECIFICATION



Model Indoor Unit		AWSI-HND018-N11		
Model Outdoor Unit		AWAU-YND018-H11		
Installation Method of Pipe		Flared		
Characteristics	Units	Cooling	Heating	
		Average		
Capacity ⁽¹⁾	kW	5.0(1.4~6.2)	5.6(1.42~6.61)	
Pdesign	kW	5	5.1	
SEER /SCOP ⁽²⁾	W/W	6.8	3.9	
Energy efficiency class		A++	A	
Annual energy consumption	kWh	257	1831	
Tbiv	°C	N/A	-7	
Tol	°C	N/A	-15	
Power supply	V/Ph/Hz	220-240V/Single/50Hz		
Circuit breaker rating	A	16		
INDOOR	Fan type & quantity		Cross flow fan x1	
	Fan speeds	H/M/L	RPM	1000/900/800/500
	Air flow ⁽³⁾	H/M/L/VL	m3/hr	1000/780/650/560
	External static pressure	Min-Max	Pa	0
	Sound power level ⁽⁴⁾	H/M/L	dB(A)	58
	Sound pressure level ⁽⁵⁾	H/M/L/VL	dB(A)	45/39/33/29
	Moisture removal		l/hr	1.7
	Condensate drain tube I.D		mm	16
	Dimensions	WxHxD	mm	990 x315x218
	Weight		kg	12.5
	Package dimensions	LxWxH	mm	1065 x400x300
	Packaged weight		kg	15.4
	Stacking height		units	8
	OUTDOOR	Refrigerant control		EEV
Compressor type, model		Twin-rotary DC Inverter		
Fan type & quantity		Axial x 1		
Fan speeds		H/L	RPM	800
Air flow		H/L	m3/hr	2200
Sound power level ⁽⁴⁾		H/L	dB(A)	61
Sound pressure level ⁽⁵⁾		H/L	dB(A)	53
Dimensions		WxHxD	mm	760 x590x285
Weight			kg	36.4
Package dimensions		LxWxH	mm	887x355x645
Packaged weight			kg	38.8
Stacking height			units	4
Refrigerant type		R410A		
Refrigerant charge (standard connecting tubing length)		kg(5m)	1.25	
Additional charge per 1 meter		gr / 1m	15	
Connections between units		Liquid line	In.(mm)	1/2"(6.35)
	Suction line	In.(mm)	1/4" (12.7)	
	Max.tubing length	m.	20	
	Max.height difference	m.	8	
Operation control type		Remote control		
Heating elements		kW		
Others				

Model Indoor Unit		AWSI-HND024-N11	
Model Outdoor Unit		AWAU-YND024-H11	
Installation Method of Pipe		Flared	
Characteristics	Units	Cooling	Heating
		Average	
Capacity ⁽¹⁾	kW	7.0(2.8~7.6)	7.2(2.61~8.47)
Pdesign	kW	7.0	6.4
SEER /SCOP ⁽²⁾	W/W	5.8	3.8
Energy efficiency class		A+	A
Annual energy consumption	kWh	422	2358
Tbiv	°C	N/A	-7
Tol	°C	N/A	-15
Power supply	V/Ph/Hz	220-240V/Single/50Hz	
Circuit breaker rating	A	25	
INDOOR	Fan type & quantity		Cross flow fan x1
	Fan speeds	H/M/L/VL	RPM 1000/900/800/600 1100/950/800/600
	Air flow ⁽³⁾	H/M/L/VL	m3/hr 1450/1280/1050/980
	External static pressure	Min-Max	Pa 0
	Sound power level ⁽⁴⁾	H/M/L	dB(A) 64
	Sound pressure level ⁽⁵⁾	H/M/L/VL	dB(A) 51/48/45/42
	Moisture removal		l/hr 2.6
	Condensate drain tube I.D		mm 16
	Dimensions	WxHxD	mm 1186 x340x258
	Weight		kg 16.8
	Package dimensions	LxWxH	mm 1265x420x340
	Packaged weight		kg 21.7
	Stacking height		units 8
	OUTDOOR	Refrigerant control	
Compressor type, model		Twin-rotary DC Inverter	
Fan type & quantity		Axial x 1	
Fan speeds		H/L	RPM 800
Air flow		H/L	m3/hr 2700
Sound power level ⁽⁴⁾		H/L	dB(A) 69
Sound pressure level ⁽⁵⁾		H/L	dB(A) 59
Dimensions		WxHxD	mm 845 x700x320
Weight			kg 51.2
Package dimensions		LxWxH	mm 965x395x755
Packaged weight			kg 54.5
Stacking height			units 3
Refrigerant type		R410A	
Refrigerant charge (standard connecting tubing)		kg(5m) 2.25	
Additional charge per 1 meter		gr / 1m 30	
Connections between units		Liquid line	In.(mm)
	Suction line	In.(mm)	5/8" (15.9)
	Max.tubing length	m.	25
	Max.height difference	m.	10
Operation control type		Remote control	
Heating elements		kW	
Others			

4. Dimension

4.1 Indoor Unit

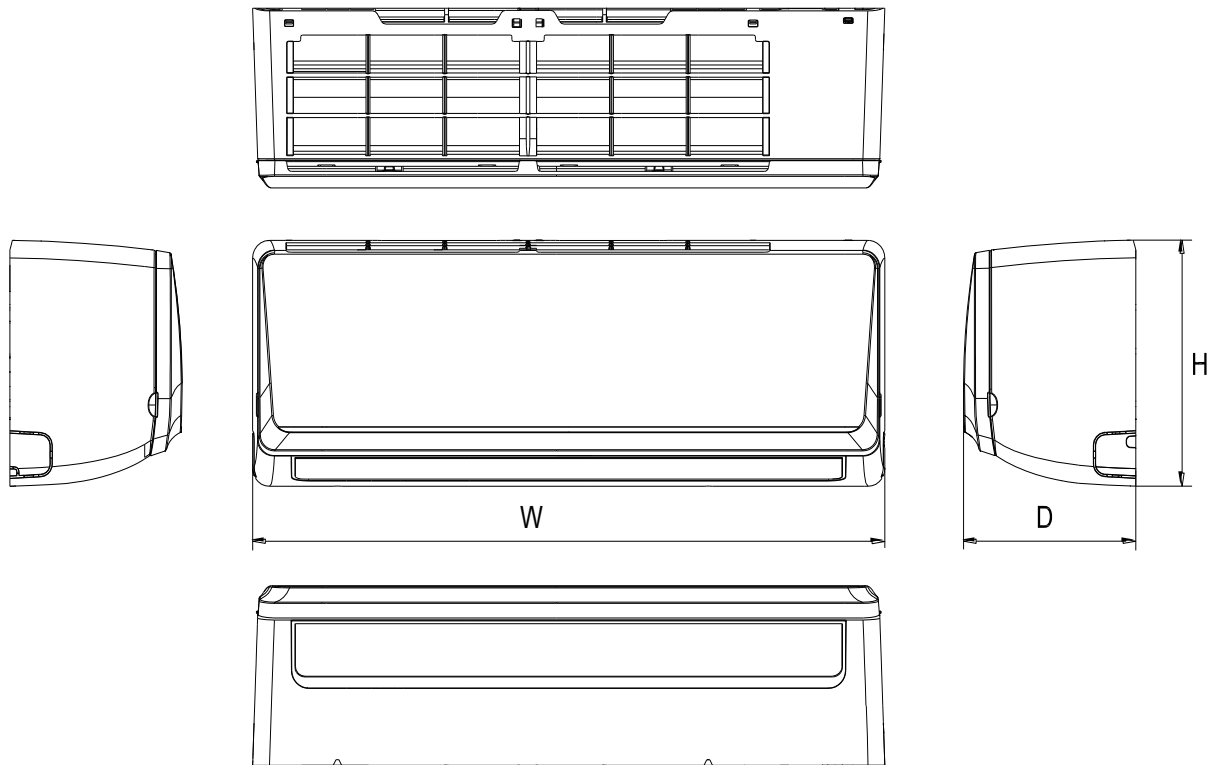

Model	W	D	H
AWSI-HND009-N11	750	205	280
AWSI-HND012-N11	835	205	280
AWSI-HND018-N11	990	225	315
AWSI-HND024-N11	1186	266	340

Unit:mm

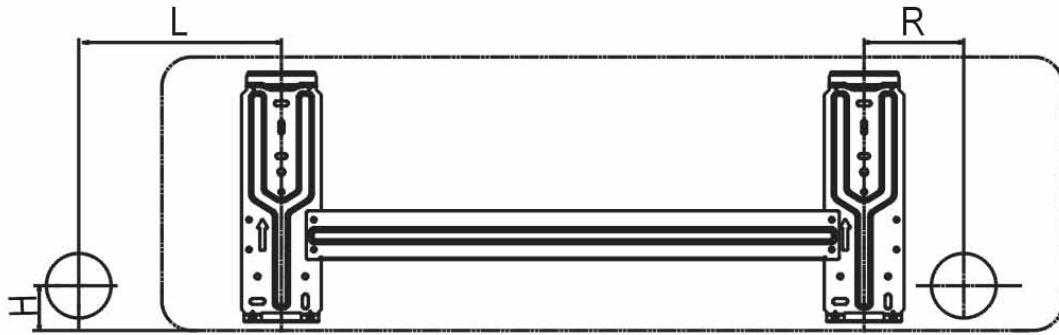

Model	L(mm)	R(mm)	H(mm)	Dimension of installation hole(mm)
AWSI-HND009-N11	180	110	45	∅ 65
AWSI-HND012-N11	140	110	45	

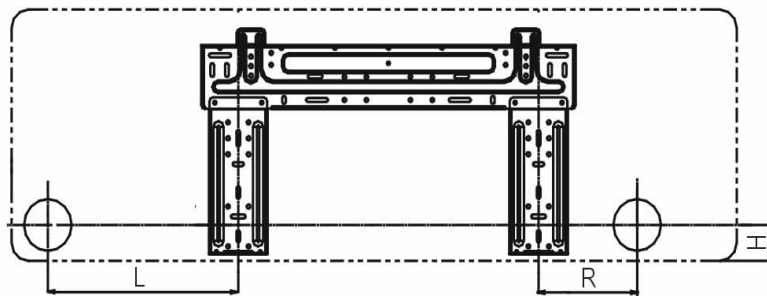

Model	L(mm)	R(mm)	H(mm)	Dimension of installation hole(mm)
AWSI-HND018-N11	260	135	45	∅ 65

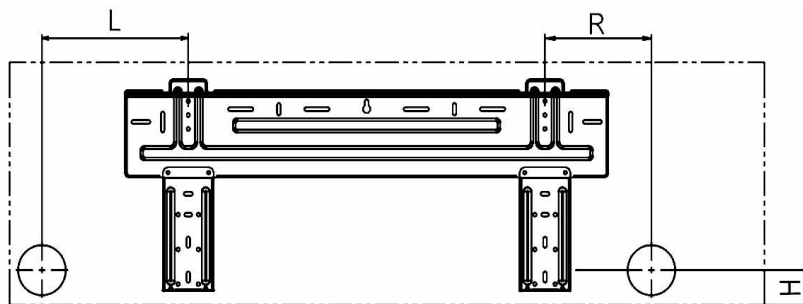

Model	L(mm)	R(mm)	H(mm)	Dimension of installation hole(mm)
AWSI-HND024-N11	275	275	45	∅ 65

4.2 Outdoor Unit

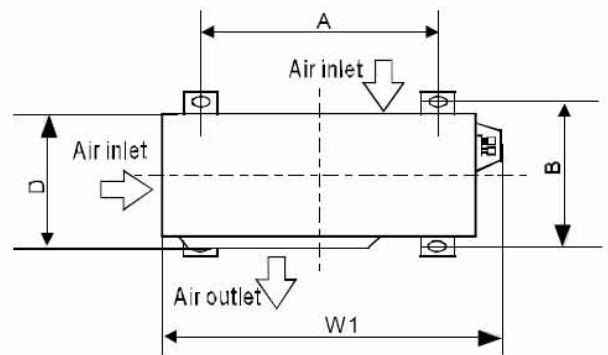
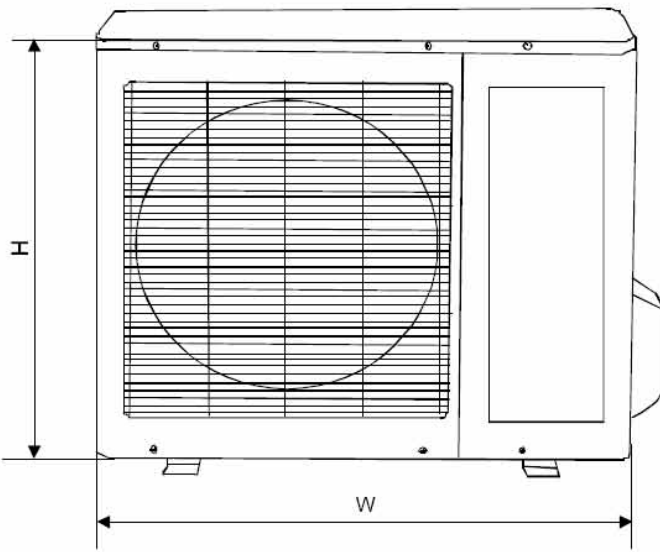
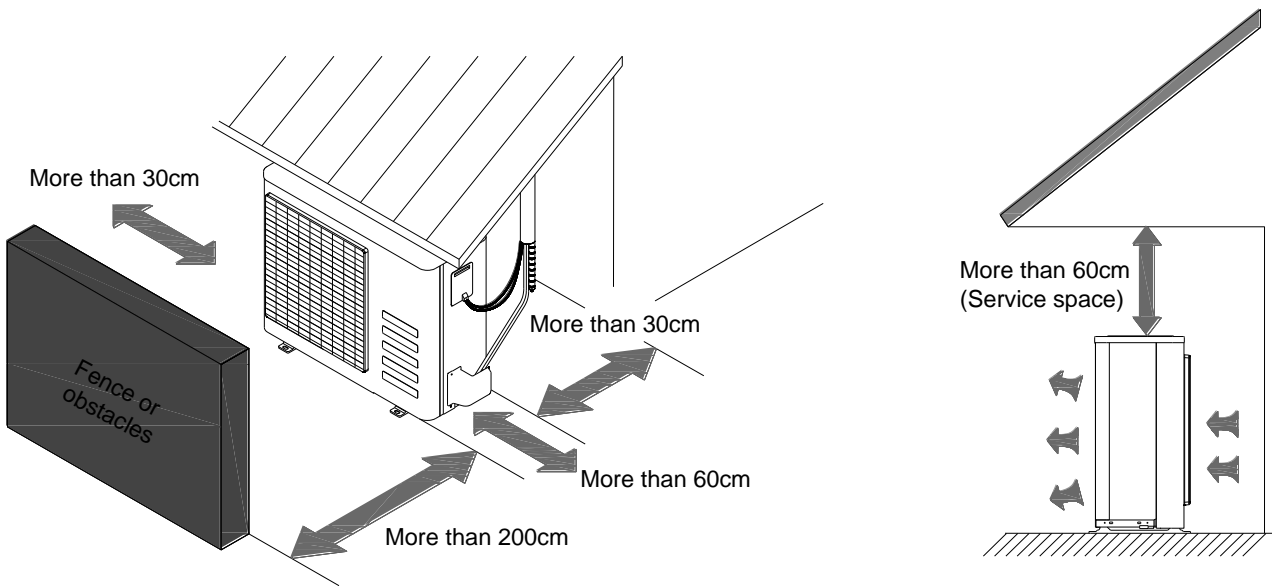

Model	W	D	H	W1	A	B
AWAU-YND009-H11	760	285	590	823	530	290
AWAU-YND012-H11						
AWAU-YND018-H11						
AWAU-YND024-H11	845	320	700	908	560	335

Unit:mm

5. Refrigerant Cycle Diagram

For AWSI-HND024-N11 model:

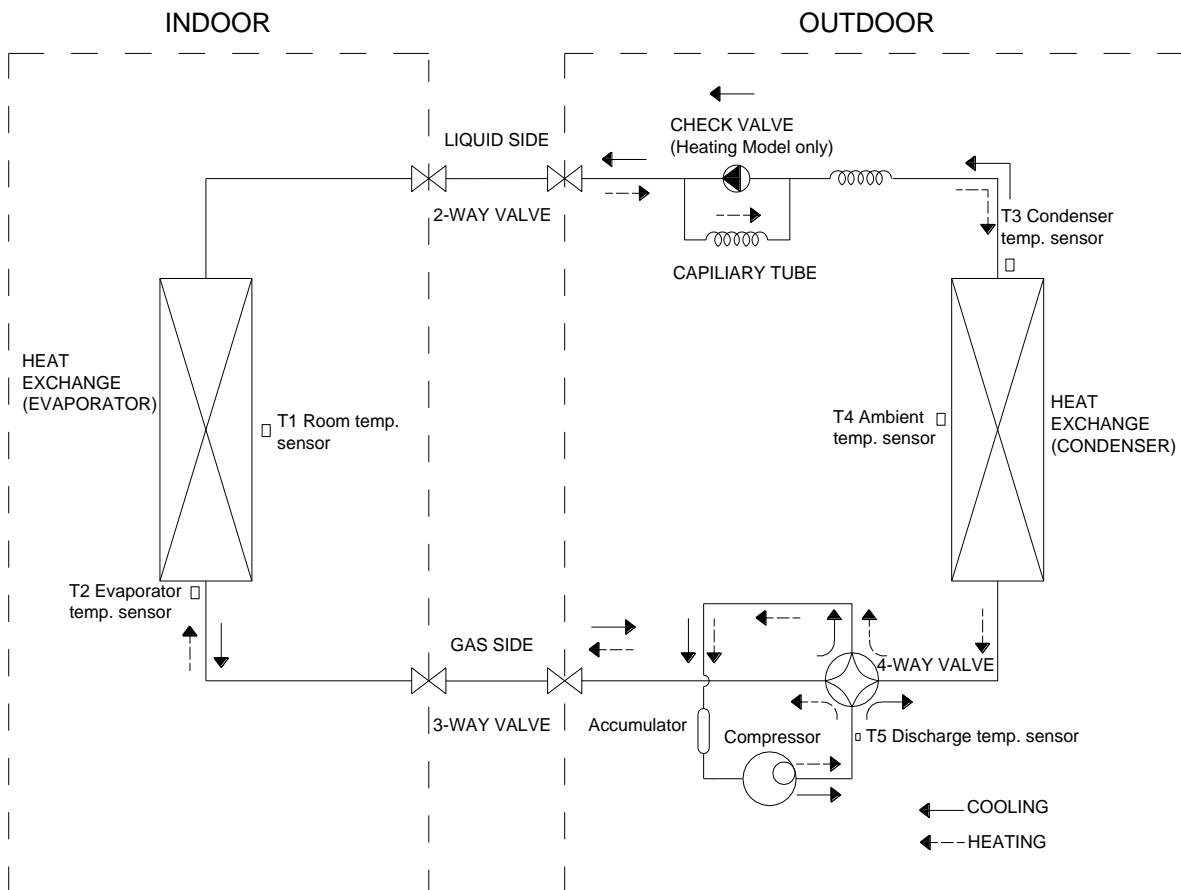

For other models:

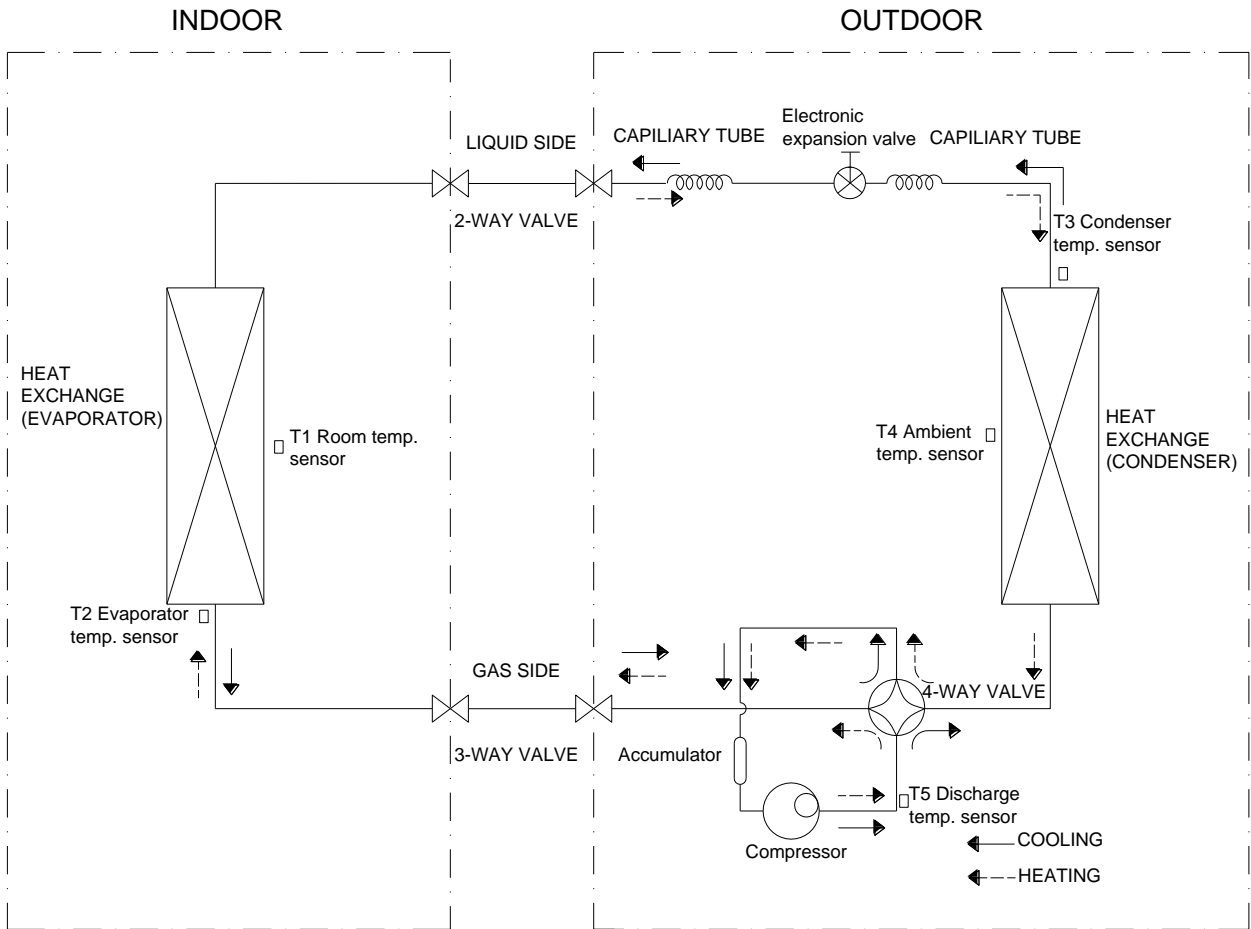

6. Wiring Diagram

6.1 Indoor Unit

AWSI-HND009-N11, AWSI-HND012-N11

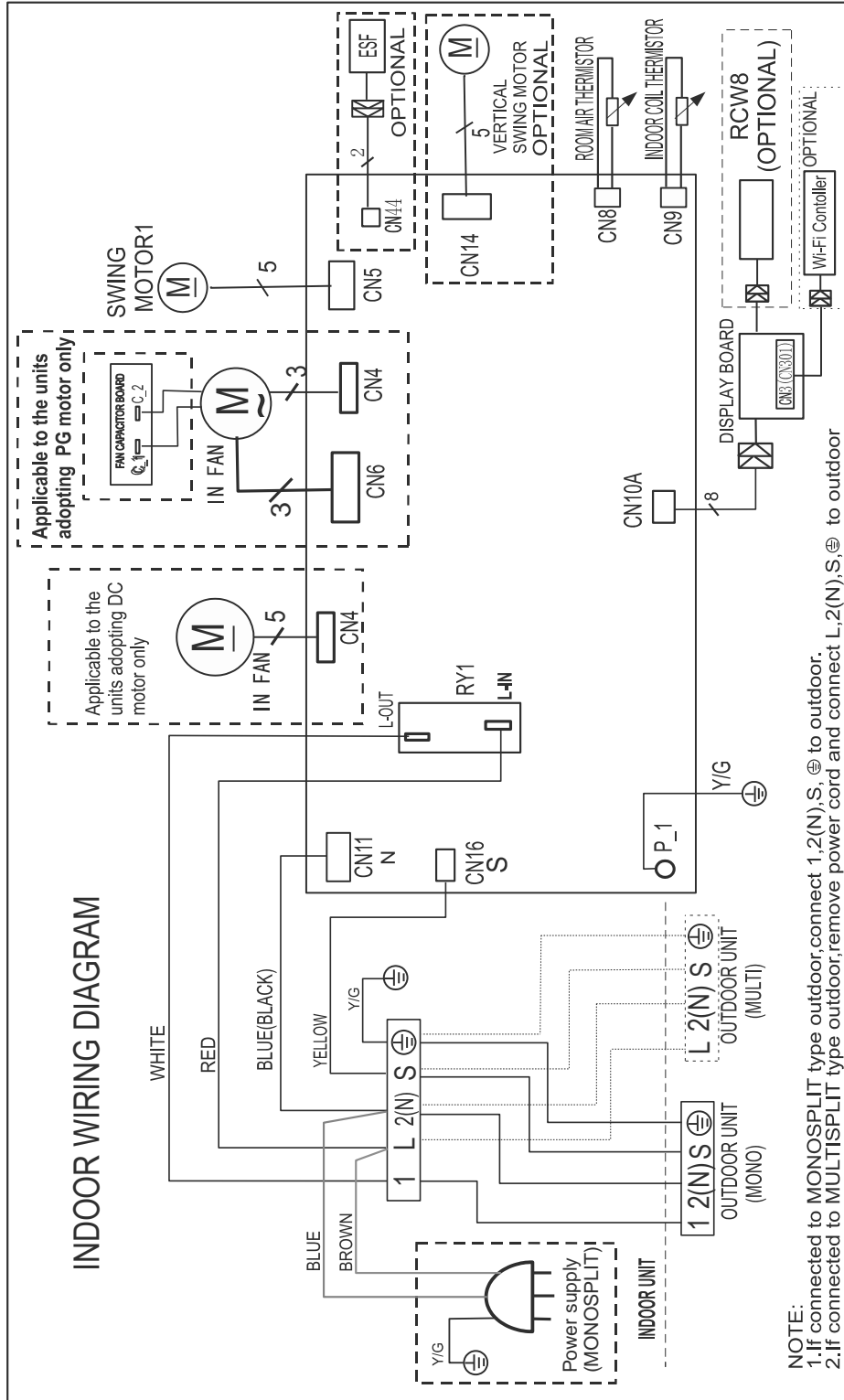

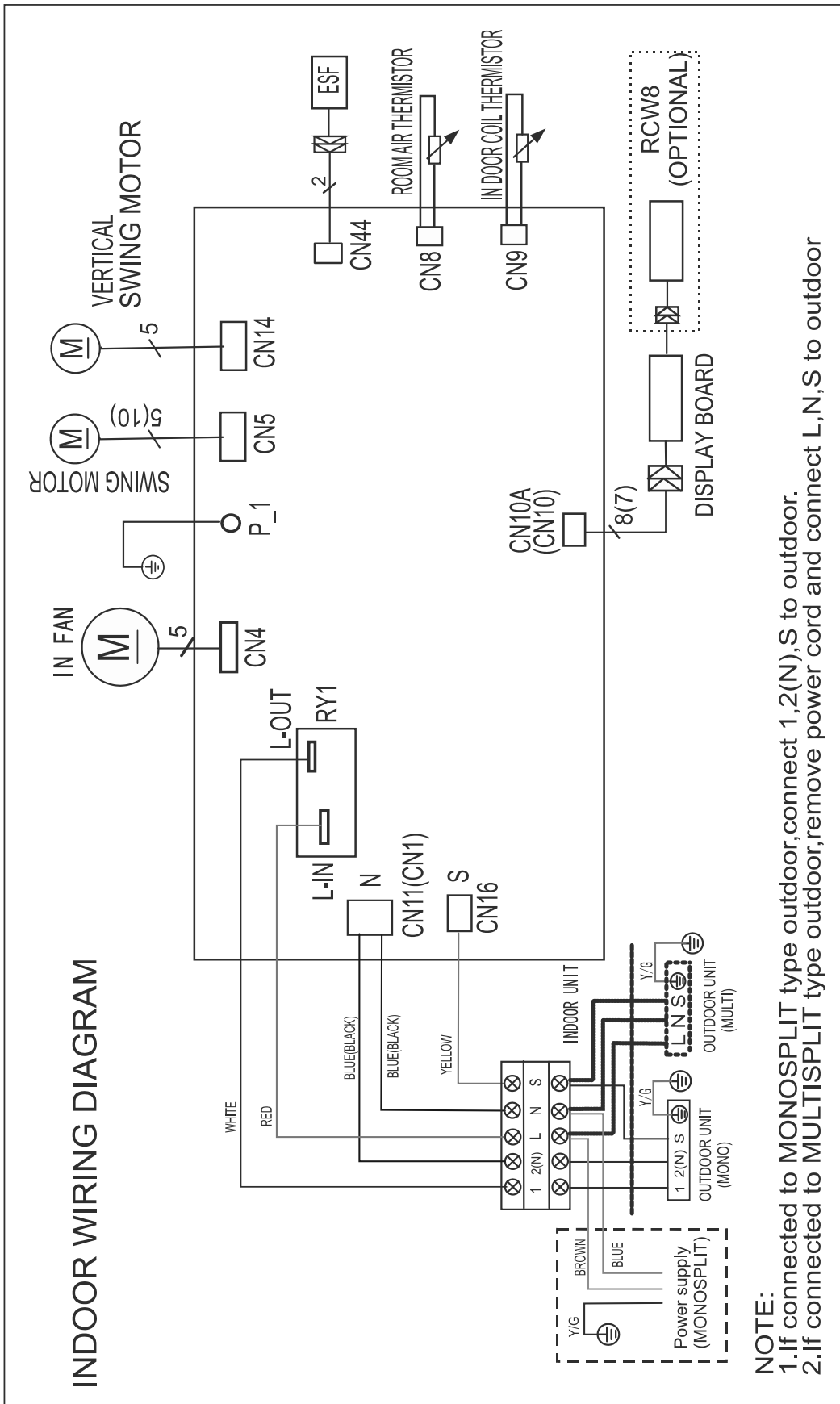

AWSI-HND024-N11

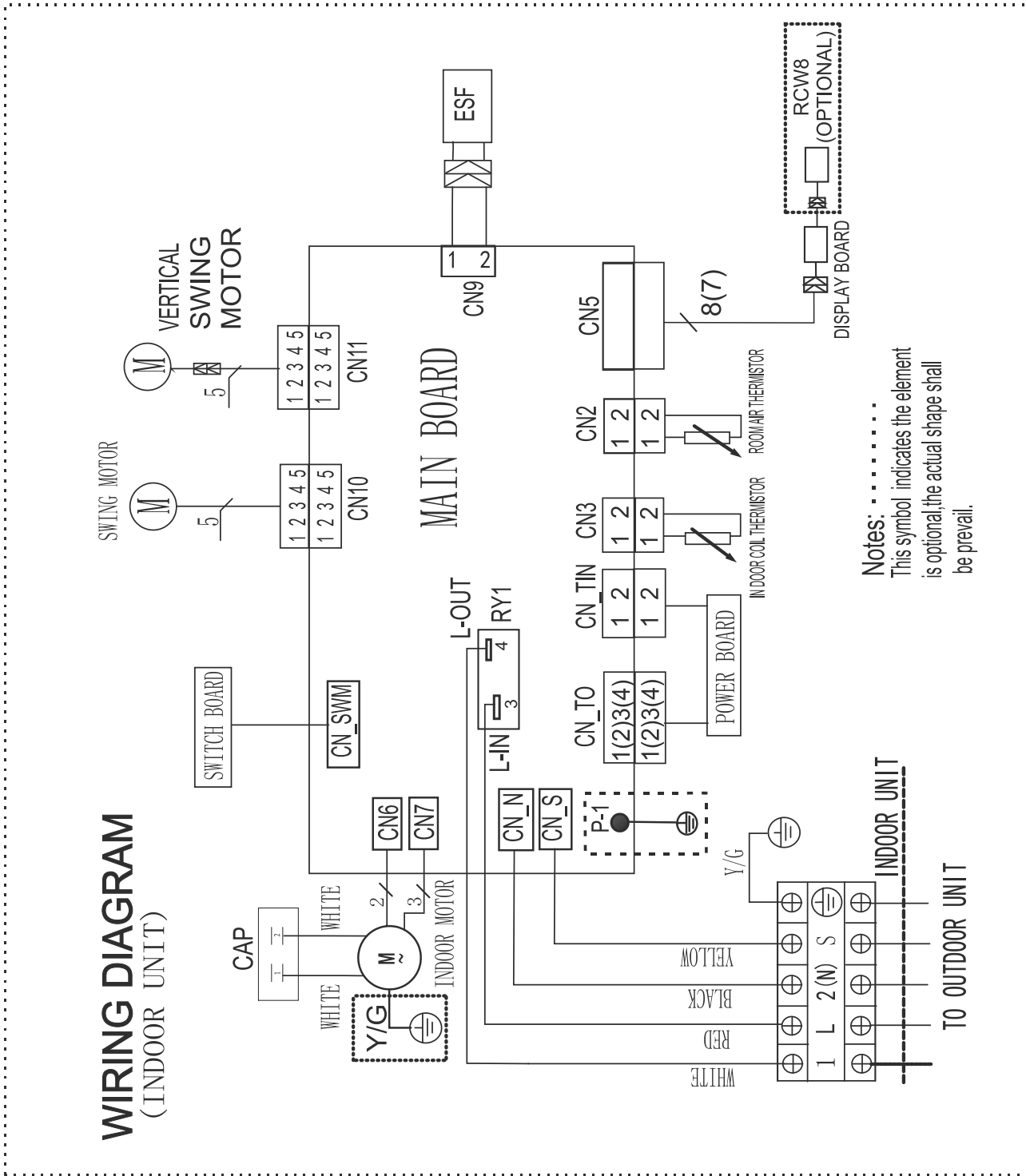

6.2 Outdoor Unit

AWAU-YND009-H11,AWAU-YND012-H11

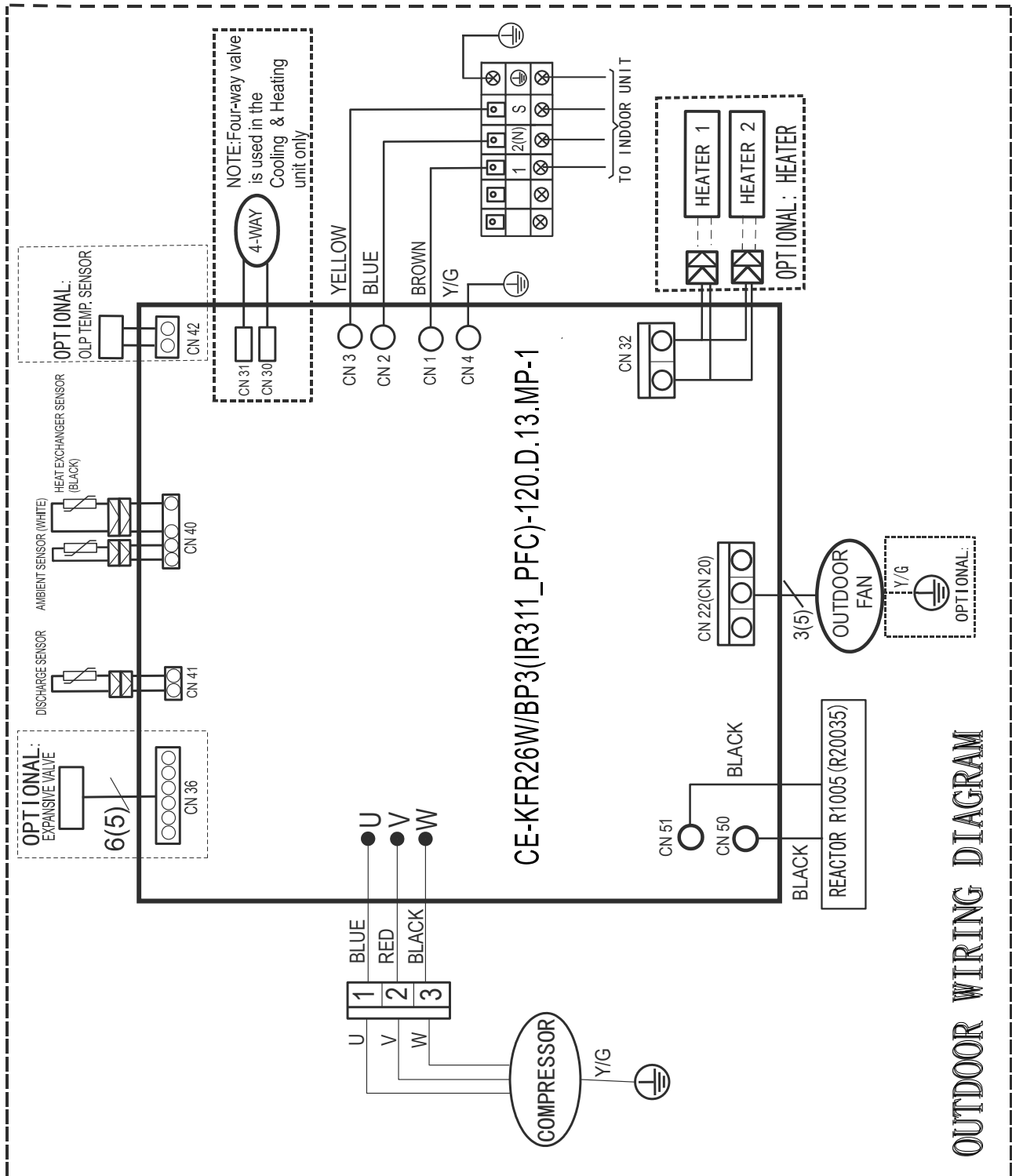

AWAU-YND018-H11

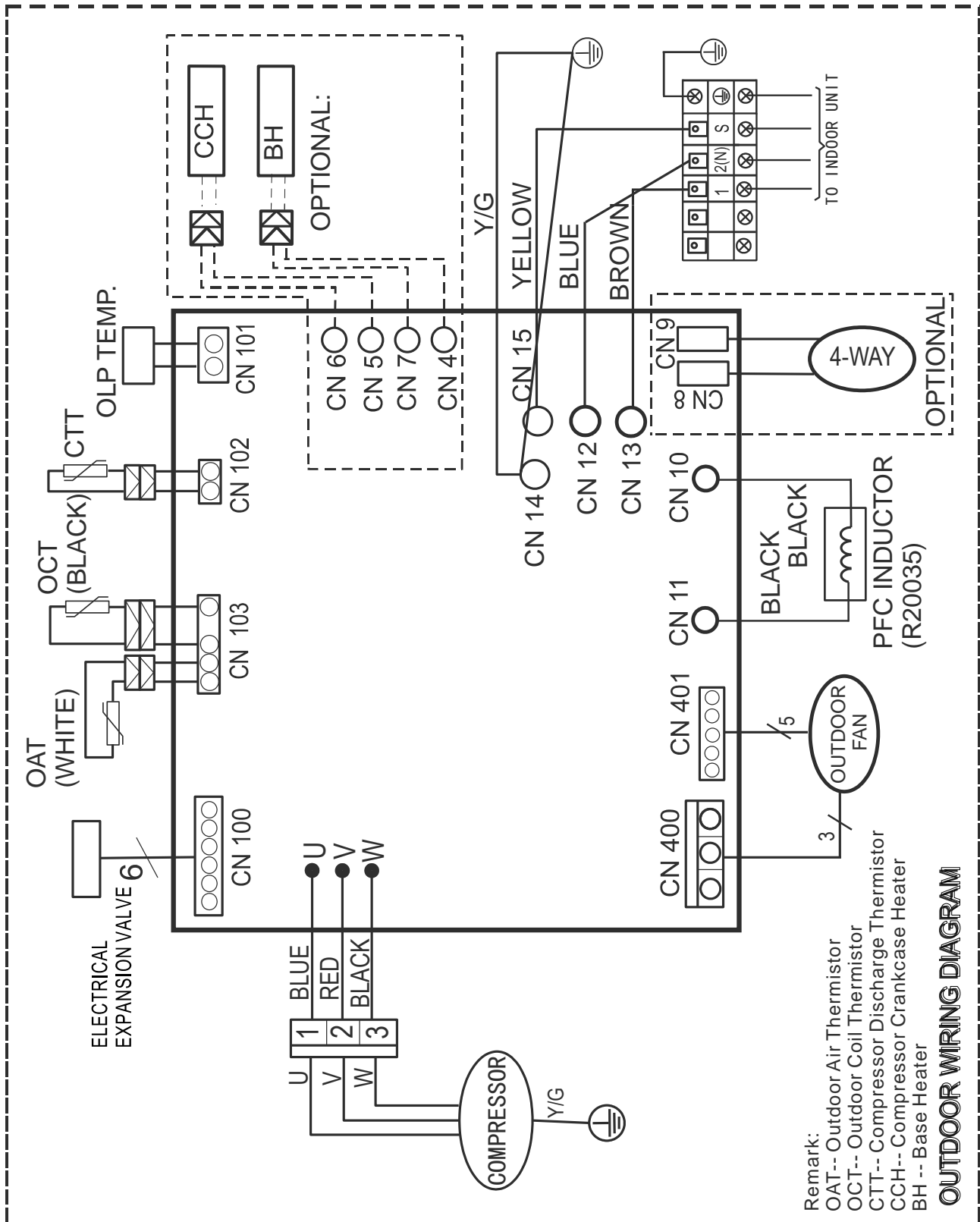

Remark:
 OAT-- Outdoor Air Thermistor
 OCT-- Outdoor Coil Thermistor
 CTT-- Compressor Discharge Thermistor
 CCH-- Compressor Crankcase Heater
 BH -- Base Heater

OUTDOOR WIRING DIAGRAM

AWAU-YND024-H11

Remark:
 OAT-- Outdoor Air Thermistor
 OCT-- Outdoor Coil Thermistor
 CTT-- Compressor Discharge Thermistor
 CCH-- Compressor Crankcase Heater
 BH -- Base Heater

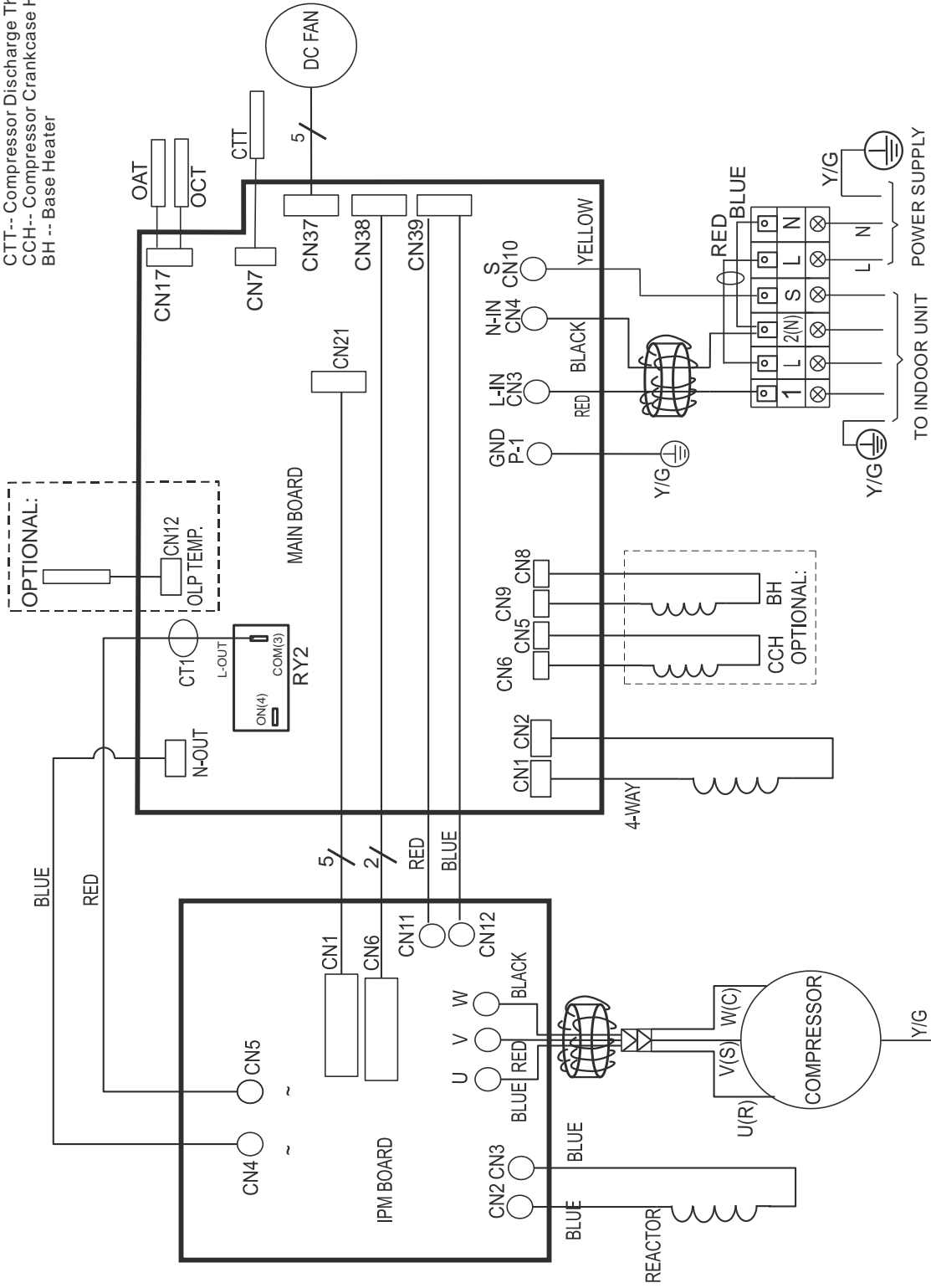

OUTDOOR WIRING DIAGRAM

7. Installation Details

7.1 Wrench torque sheet for installation

Outside diameter		Torque	Additional tightening torque
mm	inch	N.cm	N.cm
Φ6.35	1/4	1500(153kgf.cm)	1600(163kgf.cm)
Φ9.52	3/8	2500(255kgf.cm)	2600(265kgf.cm)
Φ12.7	1/2	3500(357kgf.cm)	3600(367kgf.cm)
Φ15.9	5/8	4500(459kgf.cm)	4700(479kgf.cm)
Φ19	3/4	6500(663kgf.cm)	6700(683kgf.cm)

7.2 Connecting the cables

The power cord of connect should be selected according to the following specifications sheet.

Rated current of appliance	Nominal cross-sectional area (mm ²)
>3 and ≤6	0.75
>6 and ≤10	1
>10 and ≤16	1.5
>16 and ≤25	2.5

The cable size and the current of the fuse or switch are determined by the maximum current indicated on the nameplate which located on the side panel of the unit. Please refer to the nameplate before selecting the cable, fuse and switch.

7.3 Pipe length and the elevation

The pipe length and refrigerant amount:

Model	Pipe size		Standard length (m)	Max. Elevation B (m)	Max. Length A (m)	Additional refrigerant (g/m)
	Gas	Liquid				
AWSI-HND009-N11+AWAU-YND009-H11	3/8" (Φ9.52)	1/4" (Φ6.35)	5	8	20	20
AWSI-HND012-N11+AWAU-YND012-H11						
AWSI-HND018-N11+AWAU-YND018-H11	1/2" (Φ12.7)	1/4" (Φ6.35)	5	8	20	20
AWSI-HND024-N11+AWAU-YND024-H11	5/8" (Φ15.9)	3/8" (Φ9.52)	5	10	25	40

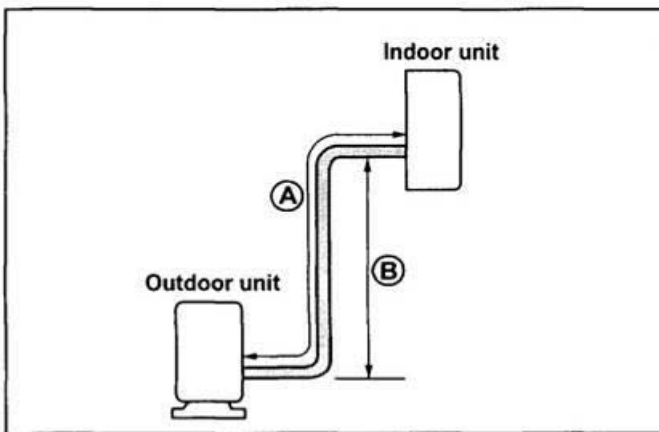

Caution:

The capacity test is based on the standard length and the maximum permissible length is based on the system reliability.

Oil trap:

When the outdoor unit is installed above the indoor unit an oil trap is required every 3m along the suction line at the lowest point. In case the indoor unit is installed above the outdoor, no trap is required.

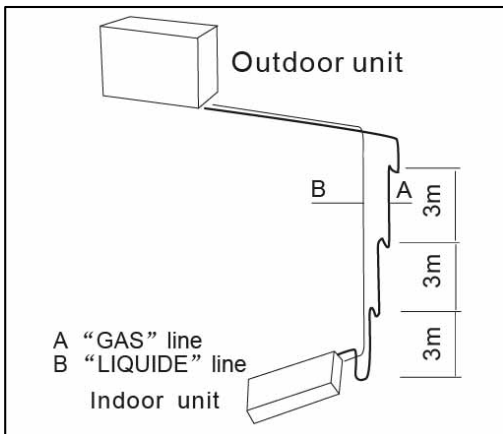

7.4 Installation for the first time

Air and moisture in the refrigerant system have undesirable effects as below:

- Pressure in the system rises.
- Operating current rises.
- Cooling or heating efficiency drops.
- Moisture in the refrigerant circuit may freeze and block capillary tubing.
- Water may lead to corrosion of parts in the refrigerant system.

Therefore, the indoor units and the pipes between indoor and outdoor units must be leak tested and evacuated to remove gas and moisture from the system.

Gas leak check (Soap water method):

Apply soap water or a liquid neutral detergent on the indoor unit connections or outdoor unit connections by a soft brush to check for leakage of the connecting points of the piping. If bubbles come out, the pipes have leakage.

1. Air purging with vacuum pump

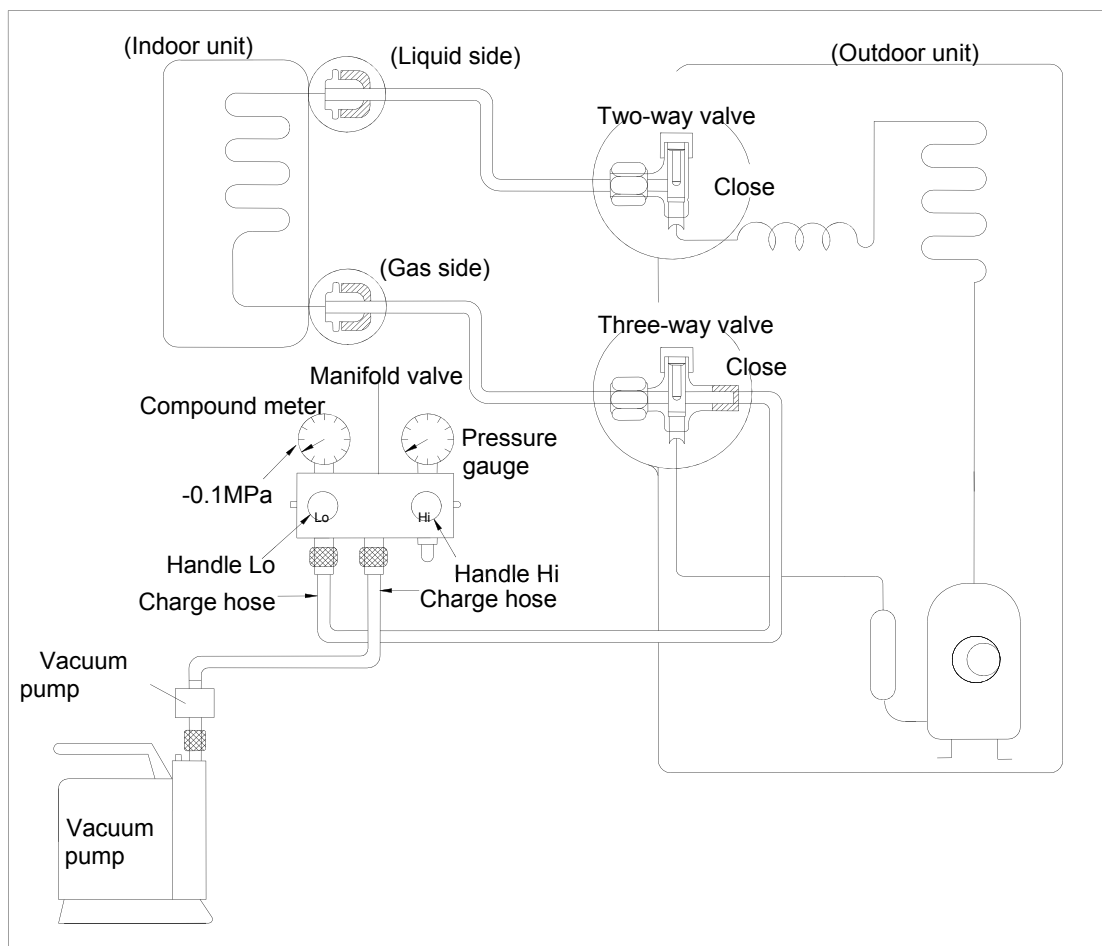

- 1) Completely tighten the flare nuts of the indoor and outdoor units, confirm that both the 2-way and 3-way valves are set to the closed position.
- 2) Connect the charge hose with the push pin of handle lo to the 3-way valves gas service port..
- 3) Connect the charge hose of handle hi connection to the vacuum pump.
- 4) Fully open the handle Lo of the manifold valve.
- 5) Operate the vacuum pump to evacuate.

6) Make evacuation for 30 minutes and check whether the compound meter indicates -0.1Mpa. If the meter does not indicate -0.1Mpa after pumping 30 minutes, it should be pumped 20 minutes more. If the pressure can't achieve -0.1Mpa after pumping 50 minutes, please check if there are some leakage points.

Fully close the handle Lo valve of the manifold valve and stop the operation of the vacuum pump. Confirm that the gauge needle does not move (approximately 5 minutes after turning off the vacuum pump).

7) Turn the flare nut of the 3-way valves about 45° counterclockwise for 6 or 7 seconds after the gas coming out, then tighten the flare nut again. Make sure the pressure display in the pressure indicator is a little higher than the atmosphere pressure. Then remove the charge hose from the 3 way valve.

8) Fully open the 2 way valve and 3 way valve and securely tighten the cap of the 3 way valve.

2. Air purging by refrigerant

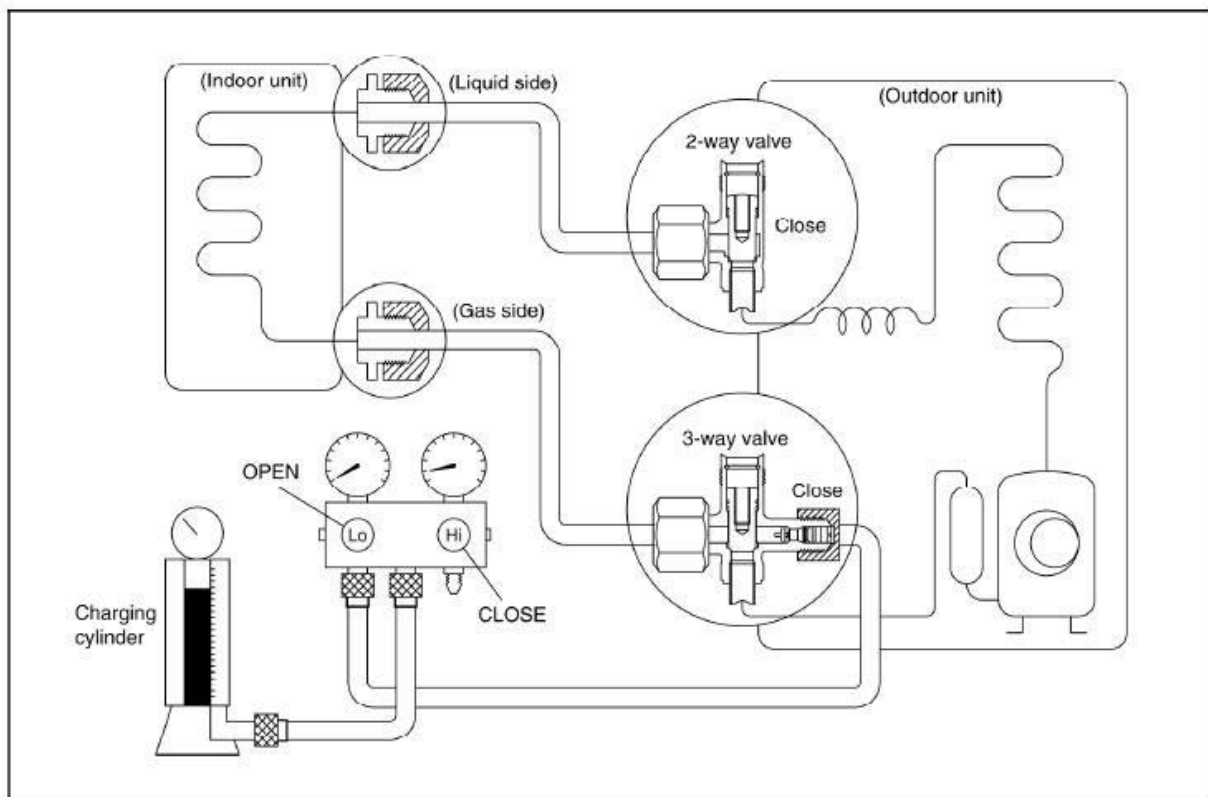

Procedure:

- 1). Confirm that both the 2-way and 3-way valves are set to the closed position.
- 2). Connect the charge set and a charging cylinder to the service port of the 3-way valve.
- 3). Air purging.

Open the valves on the charging cylinder and the charge set. Purge the air by loosening the flare nut on the 2-way valve approximately 45° for 3 seconds then closing it for 1 minute; repeat 3 times.

After purging the air, use a torque wrench to tighten the flare nut on the 2-way valve.

- 4). Check the gas leakage.

Check the flare connections for gas leakage.

- 5). Discharge the refrigerant.

Close the valve on the charging cylinder and discharge the refrigerant by loosening the flare nut on the 2-way valve approximately 45° until the gauge indicates 0.3 to 0.5 Mpa.

- 6). Disconnect the charge set and the charging cylinder, and set the 2-way and 3-way valves to the

INSTALLATION

open position.

Be sure to use a hexagonal wrench to operate the valve stems.

7). Mount the valve stems nuts and the service port cap.

Be sure to use a torque wrench to tighten the service port cap to a torque 18N·m.

Be sure to check the gas leakage.

3. Adding the refrigerant if the pipe length >5m

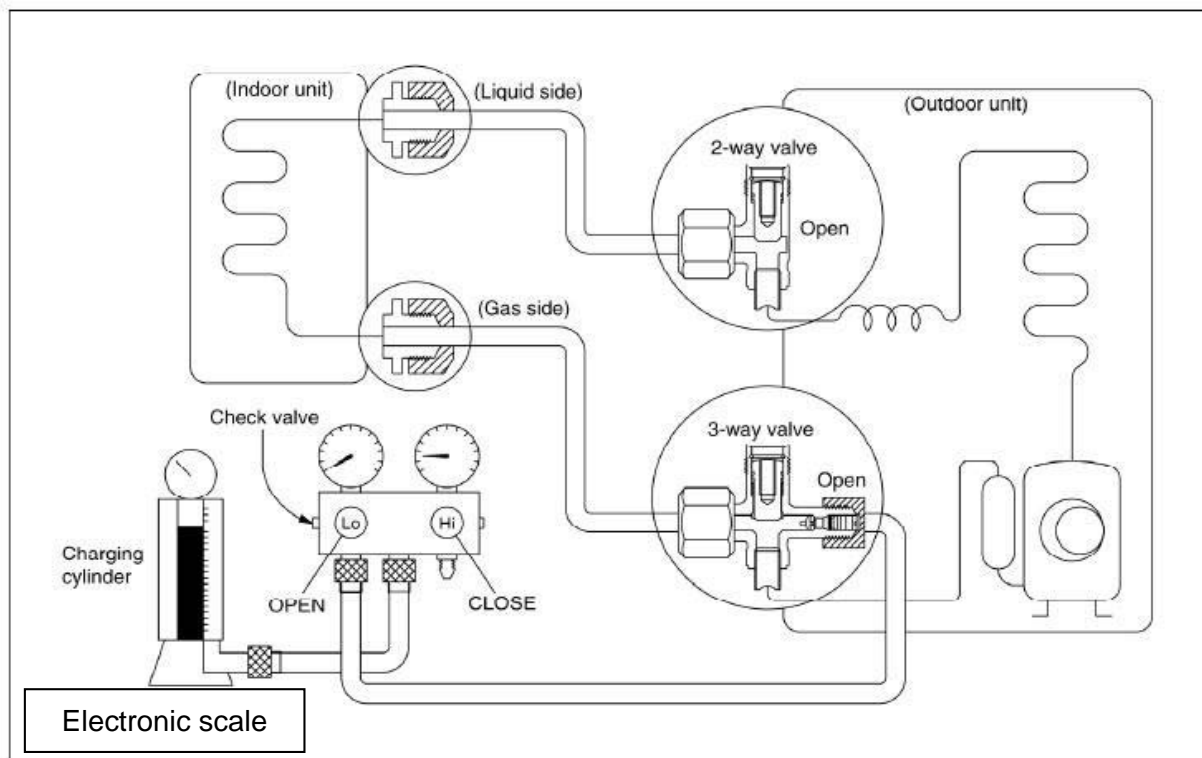

Procedure:

- 1). Connect the charge hose to the charging cylinder, open the 2-way valve and the 3-way valve. Connect the charge hose which you disconnected from the vacuum pump to the valve at the bottom of the cylinder. If the refrigerant is R410A, make the cylinder bottom up to ensure the liquid charge.
- 2). Purge the air from the charge hose.
Open the valve at the bottom of the cylinder and press the check valve on the charge set to purge the air (be careful of the liquid refrigerant).
- 3) Put the charging cylinder onto the electronic scale and record the weight.
- 4) Operate the air conditioner at the cooling mode.
- 5) Open the valves (Low side) on the charge set and charge the system with liquid refrigerant.
- 6).When the electronic scale displays the proper weight (refer to the table), disconnect the charge hose from the 3-way valve's service port immediately and turn off the air conditioner before disconnecting the hose.
- 7). Mount the valve stem caps and the service port
Use torque wrench to tighten the service port cap to a torque of 18N.m.
Be sure to check for gas leakage.

7.5 Adding the refrigerant after running the system for many years

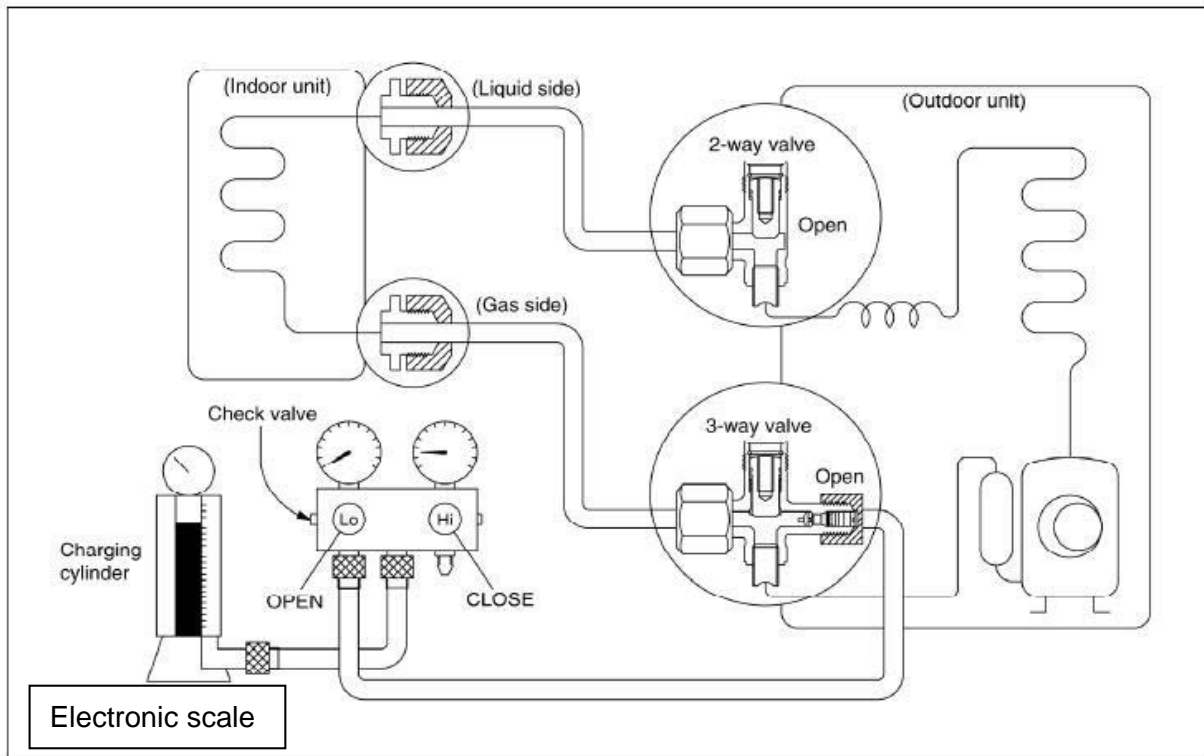

Procedure:

- 1). Connect the charge hose to the 3-way service port, open the 2-way valve and the 3-way valve. Connect the charge hose to the valve at the bottom of the cylinder. If the refrigerant is R410A, make the cylinder bottom up to ensure liquid charge.
- 2). Purge the air from the charge hose.
Open the valve at the bottom of the cylinder and press the check valve on the charge set to purge the air (be careful of the liquid refrigerant).
- 3) Put the charging cylinder onto the electronic scale and record the weight.
- 4) Operate the air conditioner at the cooling mode.
- 5) Open the valves (Low side) on the charge set and charge the system with liquid refrigerant.
- 6).When the electronic scale displays the proper weight (refer to the gauge and the pressure of the low side), disconnect the charge hose from the 3-way valve's service port immediately and turn off the air conditioner before disconnecting the hose.
- 7). Mount the valve stem caps and the service port
Use torque wrench to tighten the service port cap to a torque of 18N.m.
Be sure to check for gas leakage.

7.6 Re-installation while the indoor unit need to be repaired

1. Collecting the refrigerant into the outdoor unit

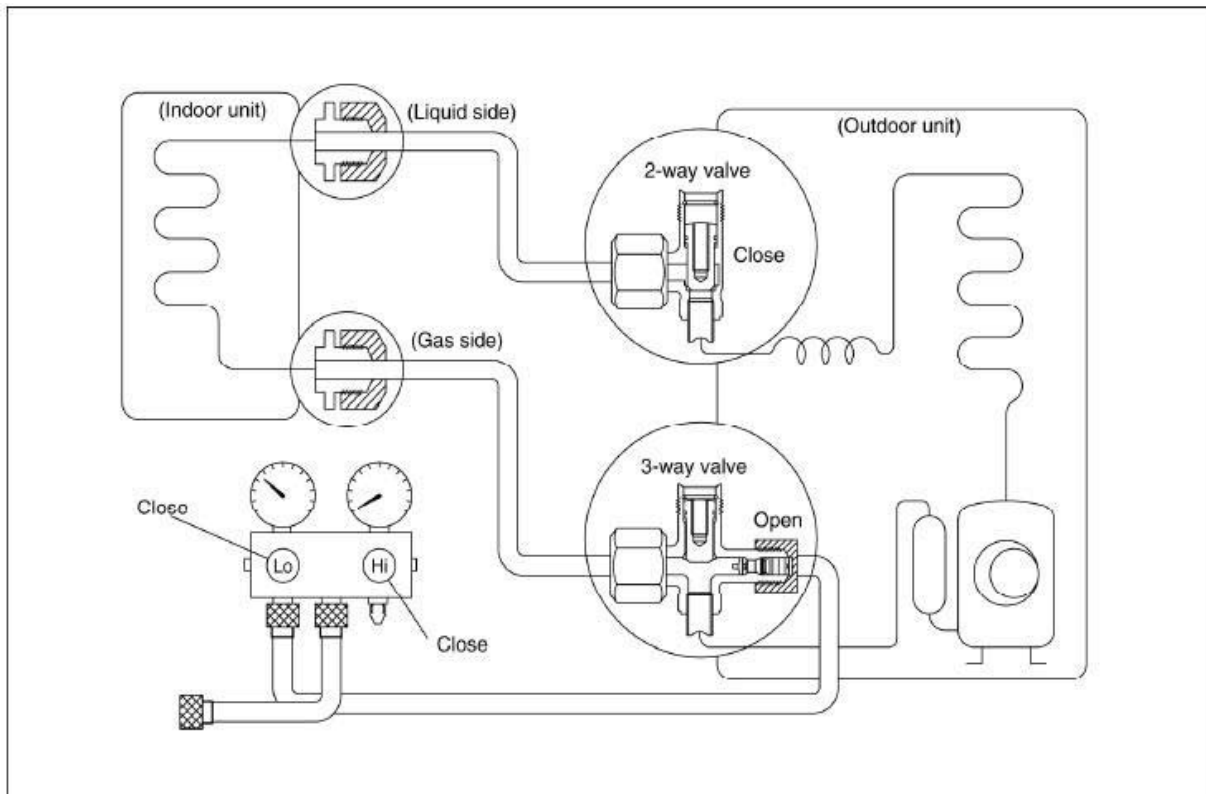

Procedure

- 1). Confirm that both the 2-way and 3-way valves are set to the opened position
Remove the valve stem caps and confirm that the valve stems are in the opened position.
Be sure to use a hexagonal wrench to operate the valve stems.
- 2). Connect the charge hose with the push pin of handle Lo to the 3-way valves gas service port.
- 3). Air purging of the charge hose.
Open the handle Lo valve of the manifold valveslightly to purge air from the charge hose for 5 seconds and then close it quickly.
- 4). Set the 2-way valve to the close position.
- 5). Operate the air conditioner at the cooling cycle and stop it when the gauge indicates 0.1MPa.
- 6).Set the 3-way valve to the closed position immediately
Do this quickly so that the gauge ends up indicating 0.3 to 0.5Mpa.
Disconnect the charge set, and tighten the 2-way and 3-way valve's stem nuts.
Use a torque wrench to tighten the 3-way valves service port cap to a torque of 18N.m.
Be sure to check for gas leakage.

2. Air purging by the refrigerant

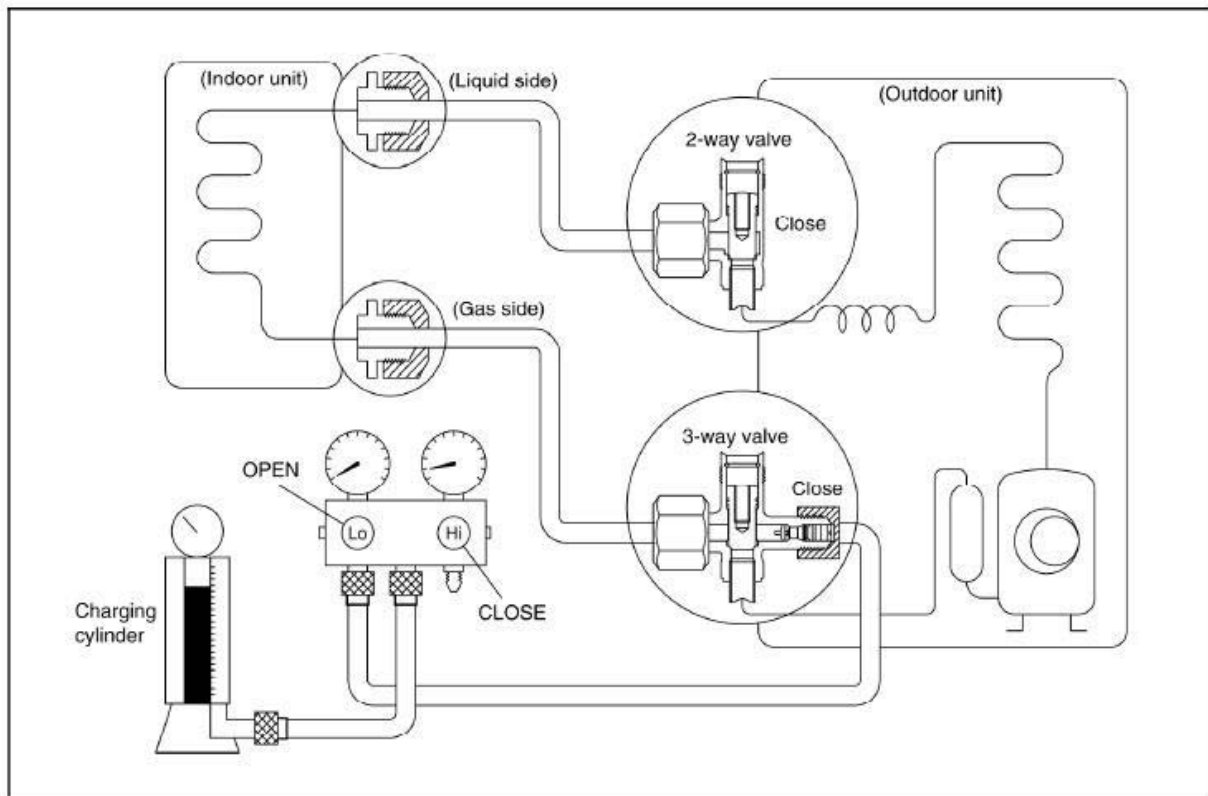

Procedure:

- 1). Confirm that both the 2-way and 3-way valves are set to the closed position.
- 2). Connect the charge set and a charging cylinder to the service port of the 3-way valve
Leave the valve on the charging cylinder closed.
- 3). Air purging.
Open the valves on the charging cylinder and the charge set. Purge the air by loosening the flare nut on the 2-way valve approximately 45° for 3 seconds then closing it for 1 minute; repeat 3 times.
After purging the air, use a torque wrench to tighten the flare nut on the 2-way valve.
- 4). Check the gas leakage
Check the flare connections for gas leakage.
- 5). Discharge the refrigerant.
Close the valve on the charging cylinder and discharge the refrigerant by loosening the flare nut on the 2-way valve approximately 45° until the gauge indicates 0.3 to 0.5 Mpa.
- 6). Disconnect the charge set and the charging cylinder, and set the 2-way and 3-way valves to the open position
Be sure to use a hexagonal wrench to operate the valve stems.
- 7). Mount the valve stems nuts and the service port cap
Be sure to use a torque wrench to tighten the service port cap to a torque 18N.m.
Be sure to check the gas leakage.

7.7 Re-installation while the outdoor unit need to be repaired

1. Evacuation for the whole system

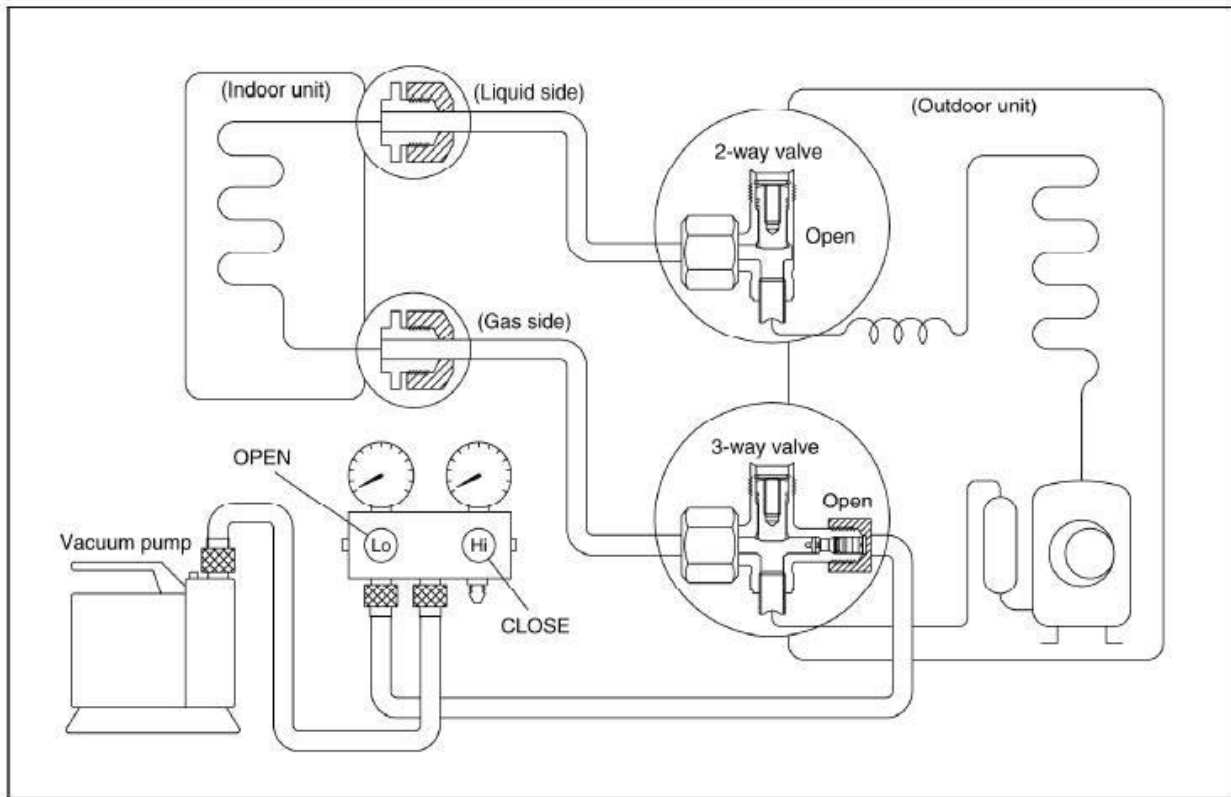

Procedure:

- 1). Confirm that both the 2-way and 3-way valves are set to the opened position.
- 2). Connect the vacuum pump to 3-way valve's service port.
- 3). Evacuation for approximately one hour. Confirm that the compound meter indicates -0.1Mpa.
- 4). Close the valve (Low side) on the charge set, turn off the vacuum pump, and confirm that the gauge needle does not move (approximately 5 minutes after turning off the vacuum pump).
- 5). Disconnect the charge hose from the vacuum pump.

2. Refrigerant charging

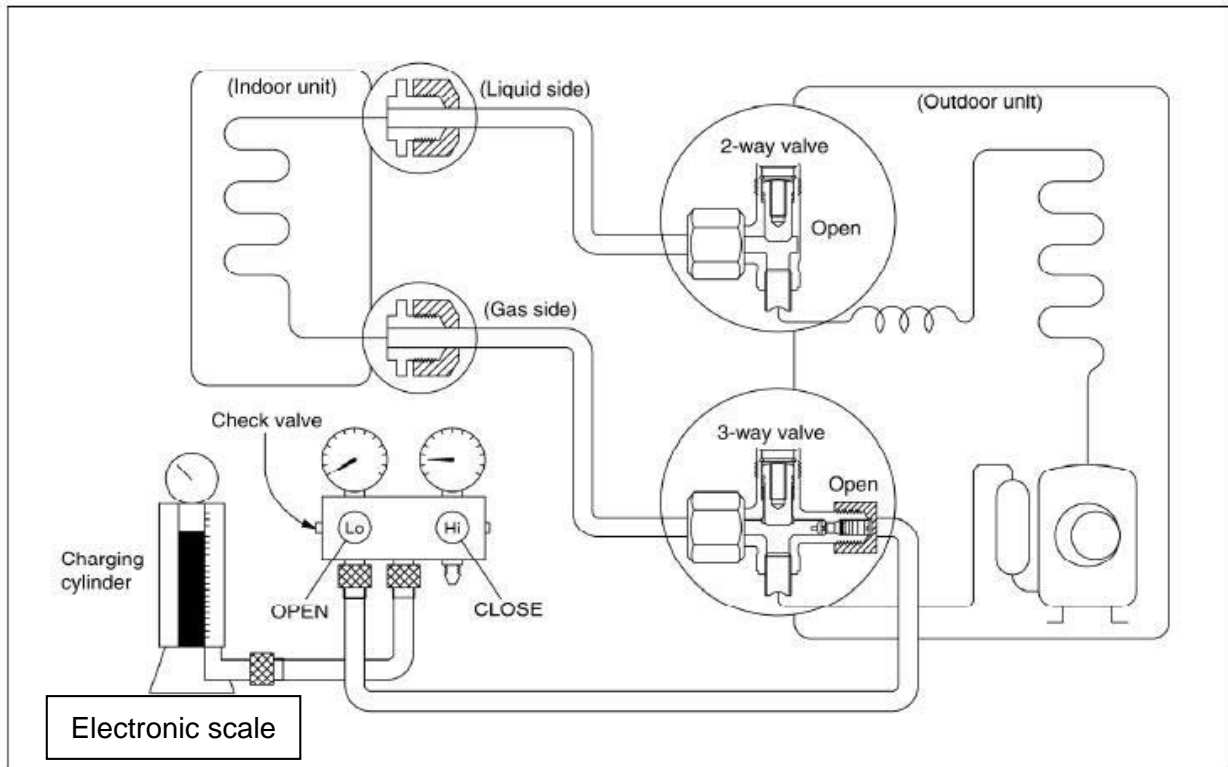

Procedure:

- 1). Connect the charge hose to the charging cylinder, open the 2-way valve and the 3-way valve
Connect the charge hose which you disconnected from the vacuum pump to the valve at the bottom of the cylinder. If the refrigerant is R410A, make the cylinder bottom up to ensure liquid charge.
- 2). Purge the air from the charge hose
Open the valve at the bottom of the cylinder and press the check valve on the charge set to purge the air (be careful of the liquid refrigerant).
- 3) Put the charging cylinder onto the electronic scale and record the weight.
- 4). Open the valves (Low side) on the charge set and charge the system with liquid refrigerant
If the system cannot be charge with the specified amount of refrigerant, or can be charged with a little at a time (approximately 150g each time) , operating the air conditioner in the cooling cycle; however, one time is not sufficient, wait approximately 1 minute and then repeat the procedure.
- 5).When the electronic scale displays the proper weight,disconnect the charge hose from the 3-way valve's service port immediately
If the system has been charged with liquid refrigerant while operating the air conditioner, turn off the air conditioner before disconnecting the hose.
- 6). Mounted the valve stem caps and the service port
Use torque wrench to tighten the service port cap to a torque of 18N.m.
Be sure to check for gas leakage

8. Operation Characteristics

Temperature Mode	Cooling operation	Heating operation	Drying operation
Room temperature	$\geq 17^{\circ}\text{C}$	$\leq 30^{\circ}\text{C}$	$> 10^{\circ}\text{C}$
Outdoor temperature	$-15^{\circ}\text{C} \sim 50^{\circ}\text{C}$	$-15^{\circ}\text{C} \sim 30^{\circ}\text{C}$	$-15^{\circ}\text{C} \sim 50^{\circ}\text{C}$

CAUTION:

1. If the air conditioner is used beyond the above conditions, certain safety protection features may come into operation and cause the unit to operate abnormally.

2. The room relative humidity should be less than 80%. If the air conditioner operates beyond this figure, the surface of the air conditioner may attract condensation. Please set the vertical air flow louver to its maximum angle (vertically to the floor), and set HIGH fan mode.

3. The optimum performance will be achieved during this operating temperature zone.

9. Electronic function

9.1 Abbreviation

- T1: Indoor room temperature(RAT)
- T2: Coil temperature of evaporator(ICT)
- T3: Coil temperature of condenser(OCT)
- T4: Outdoor ambient temperature(OAT)
- T5: Compressor discharge temperature(CTT)

9.2 Display function

9.2.1 Icon explanation on indoor display board.

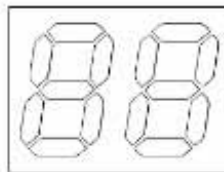

<p>2* 7 segments display</p>	<p>1.In normal situation, the setting temperature is displayed. (display room temp. in fan mode.) 2. Shows "SC" when self clean function is activated, "FP" when 8°C heating function is activated. 3. Shows the alarm code whenever there is an alarm.</p>
<p>ION INDICATOR</p>	<p>Lights up when ionizer or plasma function is activated.</p>
<p>DEFROSTING INDICATOR</p>	<p>Lights up when the unit is under defrosting operation or when the anti-cold air function is activated.</p>
<p>RUN INDICATOR</p>	<p>Lights up when the unit is in operation.</p>
<p>TIMER INDICATOR</p>	<p>Lights up when TIMER function is activated.</p>

9.3 Main Protection

9.3.1 Timedelay at restart for compressor

1 minute delay for the 1st time start-up and 3 minutes delay for others.

9.3.2 Temperature protection of compressor top

The unit will stop working when the compressor top temp. protector cut off, and will restart after the compressor top temp. protector restart.

9.3.3 Temperature protection of compressor discharge

When the compressor discharge temp. is getting higher, the running frequency will be limited as below rules:

---Compressor discharge temp. $T_5 > 115^{\circ}\text{C}$ for 5s, compressor stops and restarts up till $T_5 < 90^{\circ}\text{C}$

--- $110 < T_5 < 115^{\circ}\text{C}$, decrease the frequency to the lower level every 2 minutes.

--- $105 < T_5 < 110^{\circ}\text{C}$, keep running at the current frequency.

---- $T_5 < 105^{\circ}\text{C}$, no limit for frequency.

9.3.4 Fan speed is out of control

When indoor fan speed keeps too low (300RPM) for certain time, the unit will stop and the LED will display the failure.

9.3.5 Inverter module protection

The Inverter module has a protection function about current, voltage and temperature. If these protections happen, the corresponding code will display on indoor unit and the unit will stop working.

9.3.6 Indoor fan delayed open function

When the unit starts up, the louver will be active immediately and the indoor fan will open 10s later. If the unit runs in heating mode, the indoor fan will be also controlled by anti-cold wind function.

ELECTRONIC FUNCTION

9.3.7 Sensor protection at open circuit and breaking disconnection.

When there's one temperature sensor in malfunction, the air conditioner will display error code and will not stop immediately, to avoid the case that the air conditioner is in urgent need.

For AWSI-HND009-N11, AWSI-HND012-N11, AWSI-HND024-N11 models:

Fault temp. sensor	Operation in cooling, drying and fan only mode	Operation in heating mode
T1	Run supposed T1=26°C high fan speed	Run supposed T1=26°C high fan speed
T2	Normal	During the first 1 minute of compressor operation, indoor fan shuts off. After that, indoor fan runs at 500rpm for 1 minute and then resume to the setting fan speed.
T3	Run with compressor frequency not higher than F14	3 minutes' defrosting every 40 minutes when T4<7°C; 2 minutes' defrosting every 90 minutes when T4≥7°C.
T4	Run supposed T4=50°C	Run supposed T4=15°C
TP	Run supposed T4=50°C	Run supposed T4=15°C

For AWSI-HND018-N11 model:

Fault temp. sensor	Operation in cooling, drying and fan only mode	Operation in heating mode
T1	Run supposed T1=26°C high fan speed	Run supposed T1=26°C high fan speed
T2	Refer to table 1	Refer to table 2
T3	Run with compressor frequency not higher than F14	3 minutes' defrosting every 40 minutes when T4<7°C; 2 minutes' defrosting every 90 minutes when T4≥7°C.
T4	Run supposed T4=50°C	Run supposed T4=15°C
TP	Run supposed T4=50°C	Run supposed T4=15°C

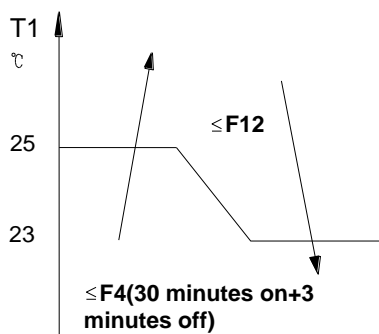

table 1

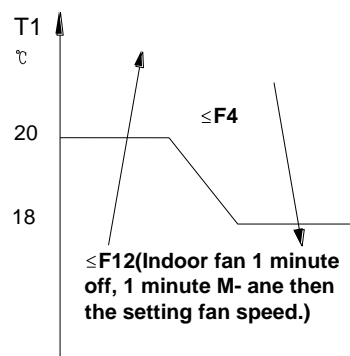

table 2

9.3.8 Refrigerant leakage detection

This function is only active in cooling mode. It can better prevent the compressor being damaged by refrigerant leakage or compressor overload.

Open condition:

Define the evaporator coil temp. T2 of the compressor just starts running as Tcool.

In the beginning 5 minutes after the compressor starts up, if $T2 < T_{cool} - 2^{\circ}\text{C}$ does not keep continuous 4 seconds and this situation happens 3 times, the display area will show "EC" and AC will turn off.

9.4 Operation Modes and Functions

9.4.1 Fan mode

- (1) Outdoor fan and compressor stop.
- (2) Temperature setting function is disabled, and no setting temperature is displayed.
- (3) Indoor fan can be set to high/med/low/auto.
- (4) The louver operates same as in cooling mode.
- (5) Auto fan:

For AWSI-HND024-N11 model:

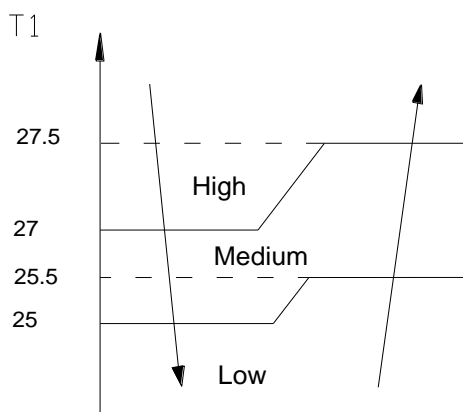

For other models:

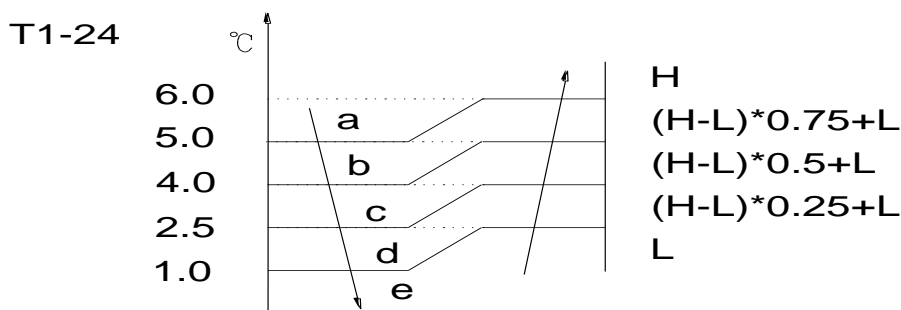

9.4.2 Cooling Mode

9.4.2.1 Compressor running rules

The maximum operation frequency of compressor after starting submits to following rule.

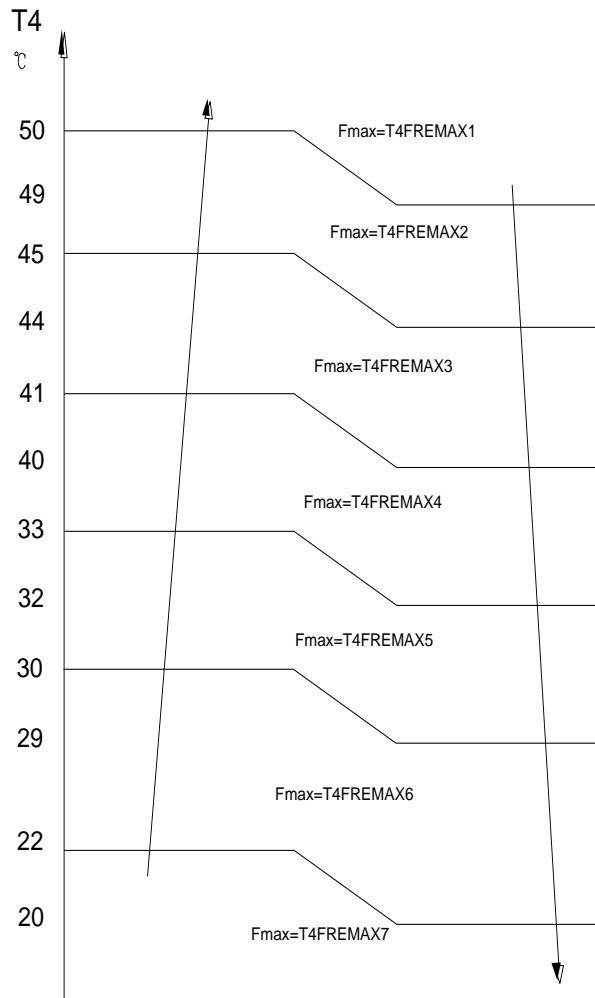

Meanwhile, the maximum frequency is limited by the indoor fan speed.

Indoor fan speed	Maximum frequency
High speed / turbo function	No limit
Silent mode	Fixed at F3

If users switch on AC by remote controller, the compressor will run at the Fmax frequency for 7 minutes according to the outdoor ambient temp. During the 7 minutes, the frequency limitation is active. 7 minutes later, the compressor running frequency will be controlled as below:

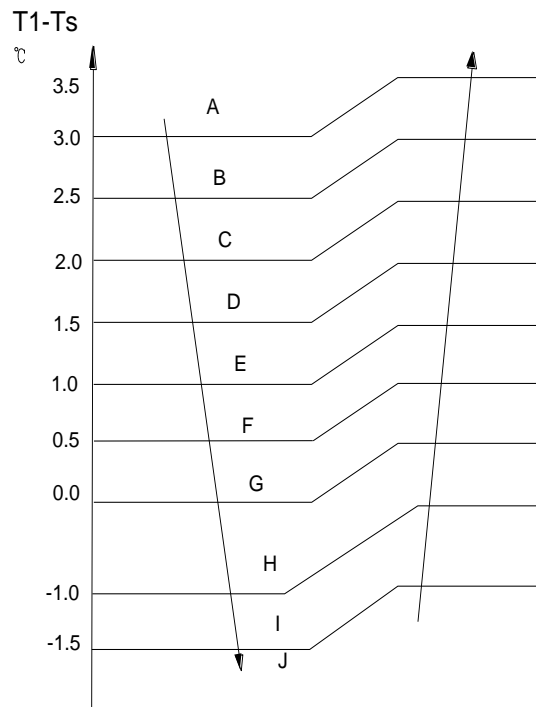

While the zones of A,B,C... are corresponding to different compressor running frequency.

Note:

When T1-Ts keeps in the same temp. zone for 3 minutes, the compressor will run as the below rules:

A: Increase the frequency to 3 grade higher until to FREMAX.

B~E: Increase the frequency to 2 grade higher until to FREMAX.

F~G: Increase the frequency to 1 grade higher until to FREMAX.

H: Keep the current frequency.

I: Decrease the frequency to 1 grade lower until to F1.

J: Run at F1 for 1h. (if T1-Ts < -2°C, the compressor will stop)

Meanwhile, the compressor running frequency is limited by the current.

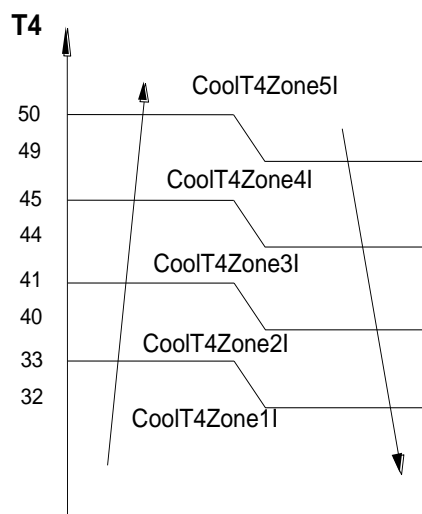

9.4.2.2 Outdoor fan running rules

Heating

- 21 A
- 19 B
- 18 B
- 16 C
- 15 C
- 13 D
- 12 D
- 10 E

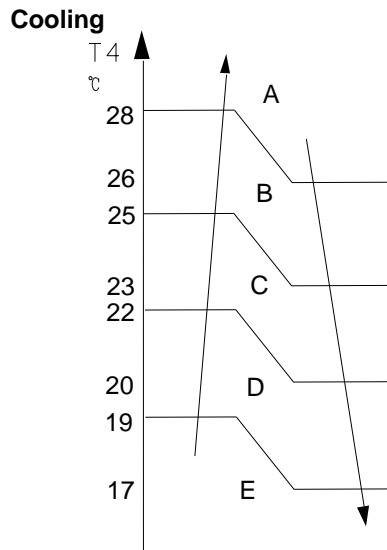

While A,B,C...means different fan speed of outdoor unit.

9.4.2.3 Indoor fan running rules

In cooling mode, indoor fan runs all the time and the speed can be selected as high, medium, low, auto and silent. When the compressor is running, the indoor fan is controlled as below:

Setting Fan speed	T1-Ts	Actual fan speed
H	4.5	$H+(H+=H+G)$
	3.0	$H (=H)$
	1.5	$H- (H=H-G)$
M	4.5	$M+(M+=M+Z)$
	3.0	$M(M=M)$
	1.5	$M-(M-=M-Z)$
L	4.5	$L+(L+=L+D)$
	3.0	$L(L=L)$
	1.5	$L-(L-=L-D)$

The auto fan acts as below rules:

For AWSI-HND024-N11 models:

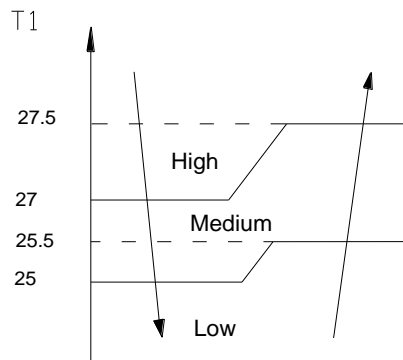

For other models:

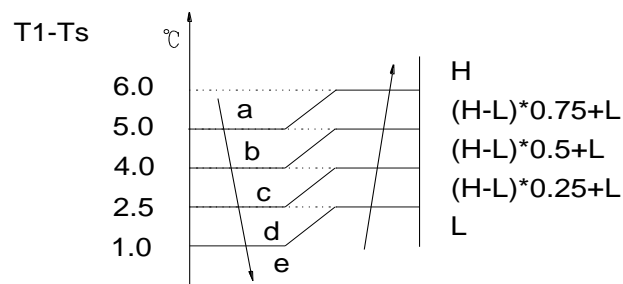

9.4.2.4 Condenser temperature protection

--- $55^{\circ}\text{C} < T3 < 60^{\circ}\text{C}$, the compressor frequency will decrease to the lower level until to F1 and then runs at F1. If $T3 < 54^{\circ}\text{C}$, the compressor will keep running at the current frequency.

--- $T3 < 52^{\circ}\text{C}$, the compressor will not limit the frequency and resume to the former frequency.

--- $T3 > 60^{\circ}\text{C}$ for 5 seconds, the compressor will stop until $T3 < 52^{\circ}\text{C}$.

9.4.2.5 Evaporator temperature protection

--- $T2 < 0^{\circ}\text{C}$, the compressor will stop and restart when $T2 \geq 5^{\circ}\text{C}$.

--- $0^{\circ}\text{C} \leq T2 < 4^{\circ}\text{C}$, the compressor frequency will be limited and decreased to the lower level

--- $4^{\circ}\text{C} \leq T2 \leq 7^{\circ}\text{C}$, the compressor will keep the current frequency.

--- $T2 > 7^{\circ}\text{C}$, the compressor frequency will not be limited.

9.4.3 Heating Mode

9.4.3.1 Compressor running rules

The maximum operation frequency of the compressor after starting submits to the following rule.

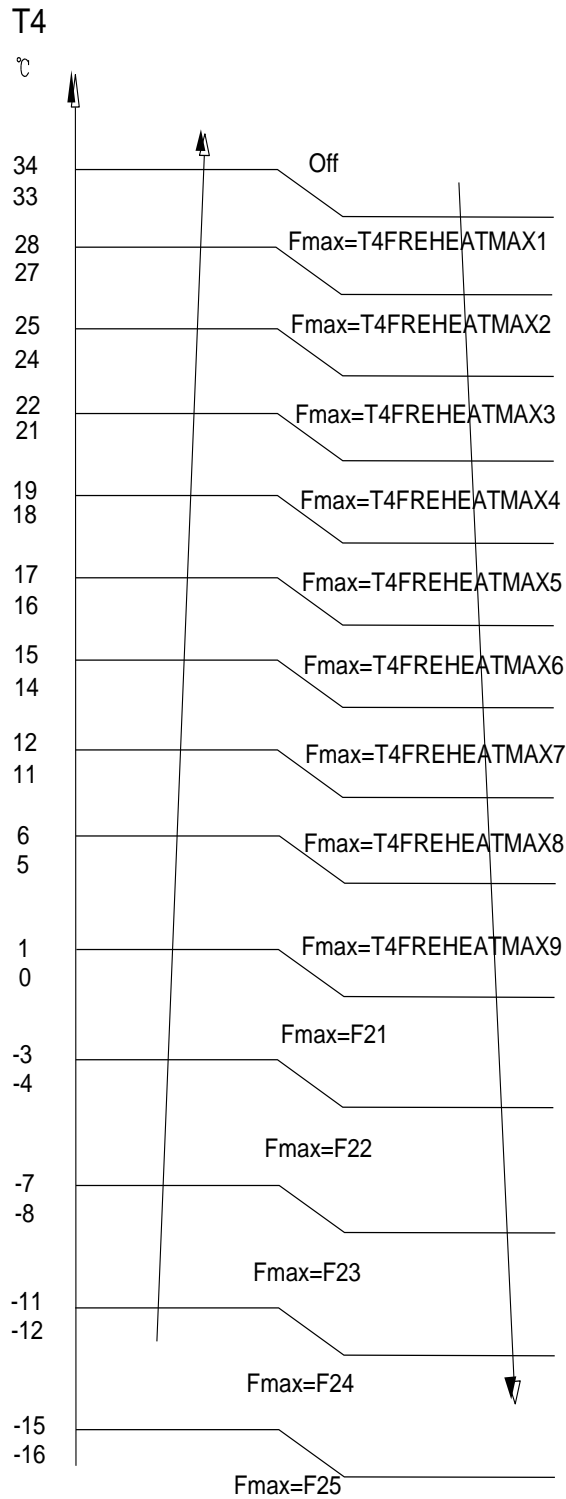

Meanwhile, the maximum frequency is limited by the indoor fan speed.

Indoor fan speed	Maximum frequency
High speed/8 degree heating/ turbo function	No limit
Medium speed	FHeatMaxMidFan
Low speed/sleep mode	FHeatMaxLowFan
Silent mode	Fixed at F3

If users switch on AC by remote controller, the compressor will run at the Fmax frequency for 7 minutes according to outdoor ambient temp. During the 7 minutes, the frequency limitation is active.

7 minutes later, the compressor running frequency will be controlled as below:

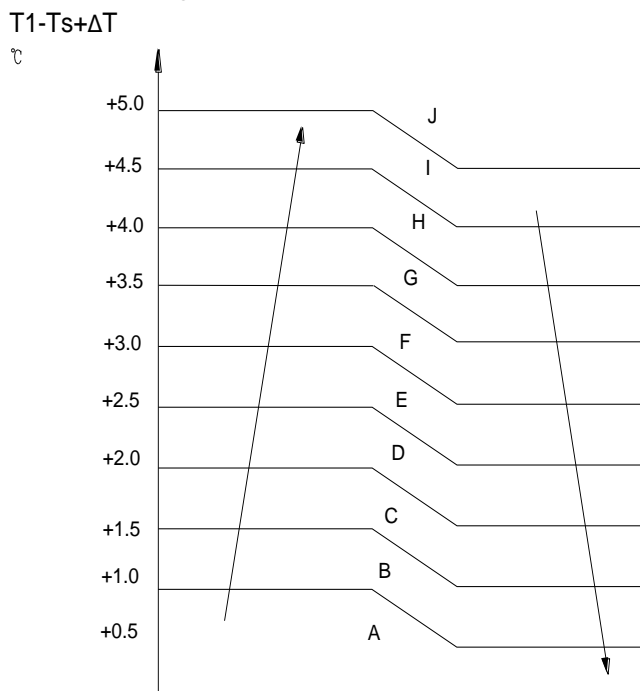

While the zones of A,B,C... are corresponding to different compressor running frequency. $\Delta T=0^{\circ}\text{C}$ as default.

Note:

When $T1-Ts$ keeps in the same temp. zone for 3 minutes, the compressor will run as the below rules:

A: Increase the frequency to 3 grade higher until to FREMAX.

B~E: Increase the frequency to 2 grade higher until to FREMAX.

F~G: Increase the frequency to 1 grade higher until to FREMAX.

H: Keep the current frequency.

I: Decrease the frequency to the 1 grade lower until to F1.

J: Run at F1 for 1h.(if $T1-Ts-\Delta T > 6^{\circ}\text{C}$, the compressor will stop)

Meanwhile, the compressor running frequency is limited by the current.

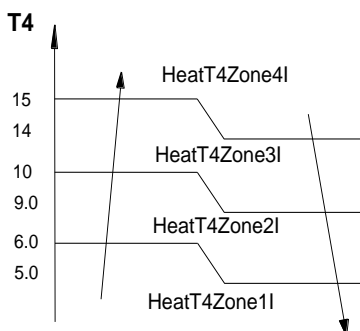

9.4.3.2 Outdoor fan running rules

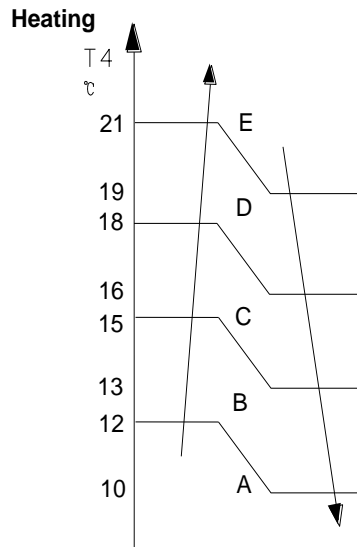

9.4.3.3 Indoor fan running rules

In heating mode, indoor fan can be selected as high, medium, low, auto and silent. The anti-cold-wind function is preferential. The running rules of anti-cold-wind function depend on both T1 and T2 that is more comfortable control.

When the compressor is running, the indoor fan is controlled as below:

Setting fan speed	T1-Ts	Actual fan speed
H	-1.5	H-(H=H-G)
	-3.0	H (=H)
	-4.5	H+(H+=H+G)
M	-1.5	M-(M-=M-Z)
	-3.0	M(M=M)
	-4.5	M+(M+=M+Z)
L	-1.5	L-(L=L-D)
	-3.0	L(L=L)
	-4.5	L+(L+=L+D)

If the compressor stops caused by the room temperature rising, the indoor fan will be forced to run 127seconds with breeze. During this period, the anti-cold-wind is disabled.

Auto fan action in heating mode:

For AWSI-HND024-N11 model:

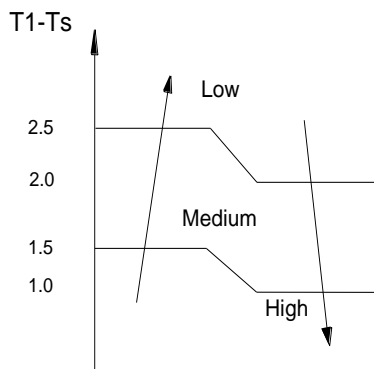

For other models:

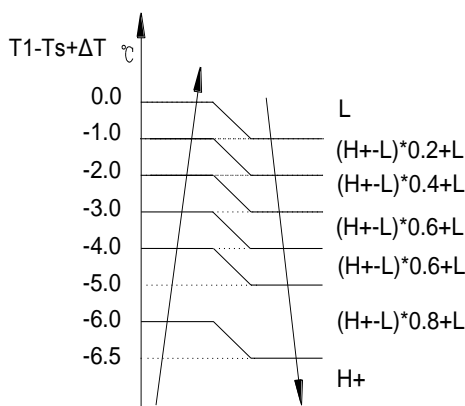

9.4.3.4 Defrosting mode

Condition of defrosting:

If any one of the following items is satisfied, AC will enter the defrosting mode.

After the compressor starts up and keeps running, mark the minimum value of T3 from the 10th minutes to 15th minutes as T30.

- 1) If the compressor cumulate running time is up to 29 minutes and $T3 < TCDI1$, $T3 + T30SUBT3ONE \leq T30$.
- 2) If the compressor cumulate running time is up to 35 minutes and $T3 < TCDI2$, $T3 + T30SUBT3TWO \leq T30$.
- 3) If the compressor cumulate running time is up to 29 minutes and $T3 < TCDI3$ for 3 minutes.
- 4) If the compressor cumulate running time is up to 120 minutes and $T3 < -15^{\circ}C$.

Condition of ending defrosting:

If any one of the following items is satisfied, the defrosting will finish and the machine will turn to normal heating mode.

- T3 rises to be higher than $TCDE1^{\circ}C$.
- T3 keeps to be higher than $TCDE2^{\circ}C$ for 80 seconds.
- The machine has run for 10 minutes in defrosting mode.

Defrosting action:

For AWSI-HND018-N11 model:

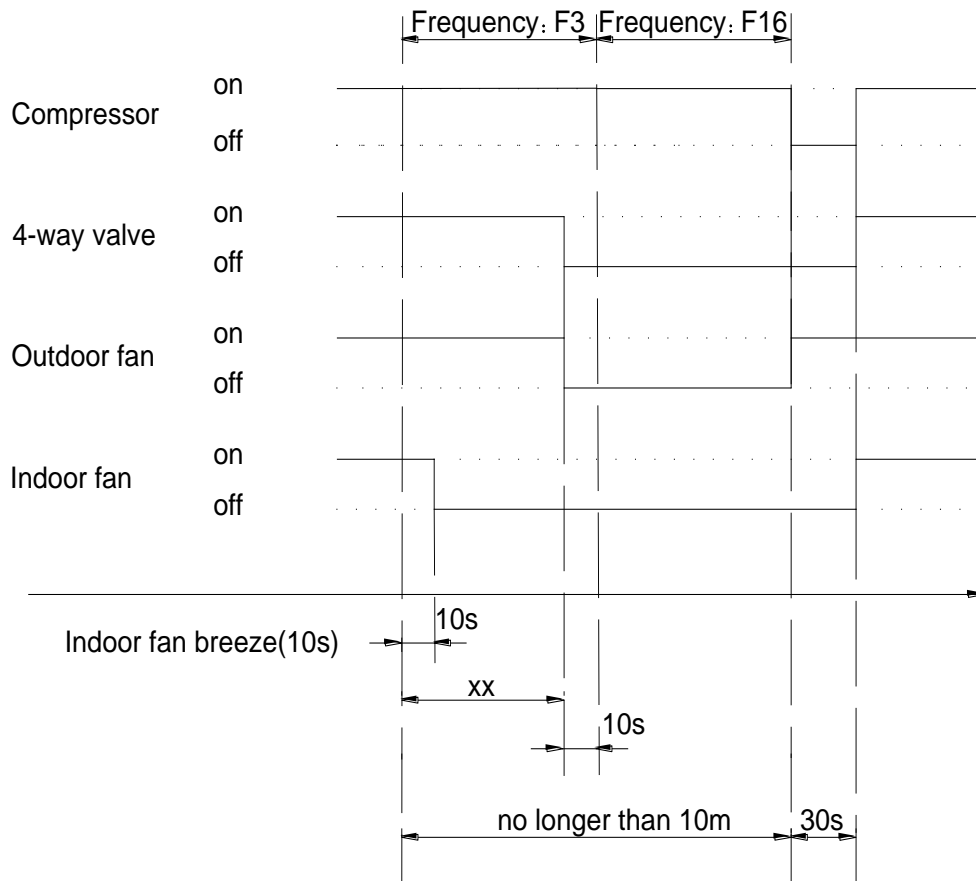

xx=60.

For AWSI-HND024-N11 model:

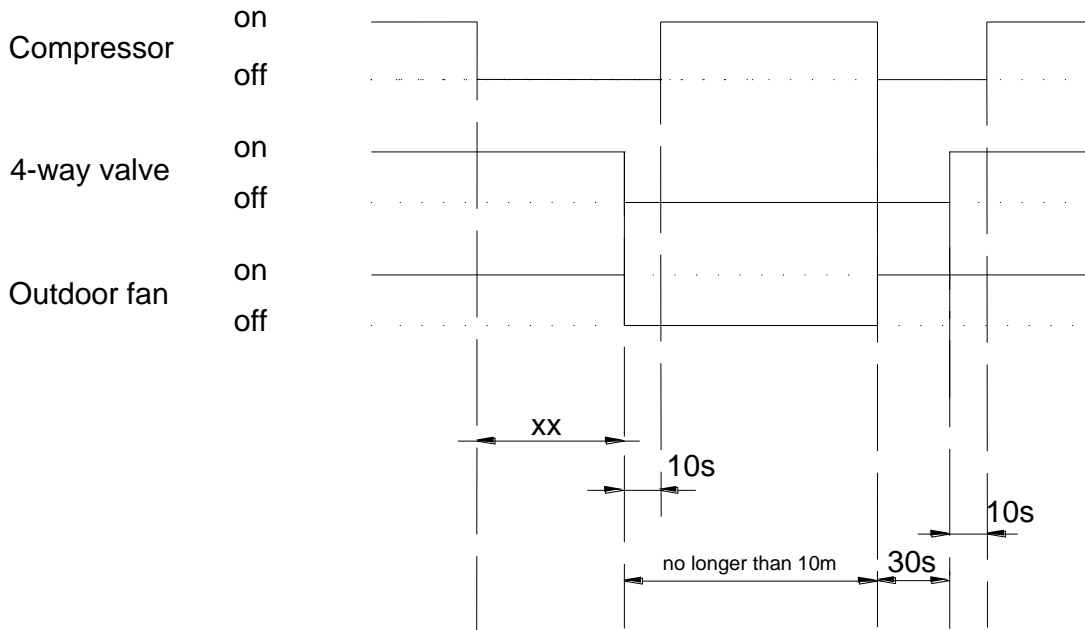

xx=20.

For AWSI-HND009-N11, AWSI-HND012-N11 models:

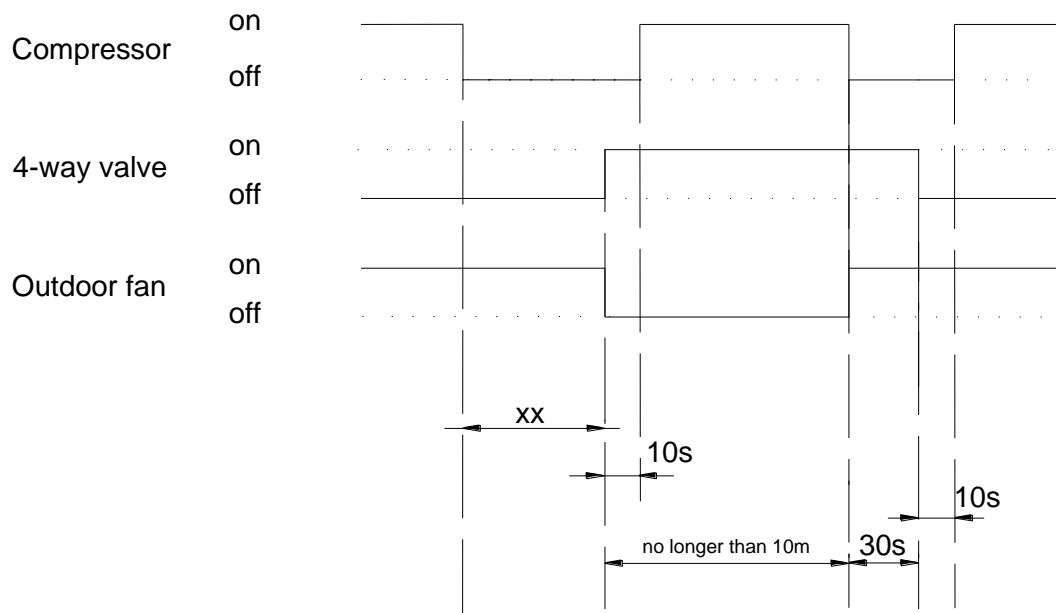

xx=20.

9.4.3.5 Evaporator coil temperature protection

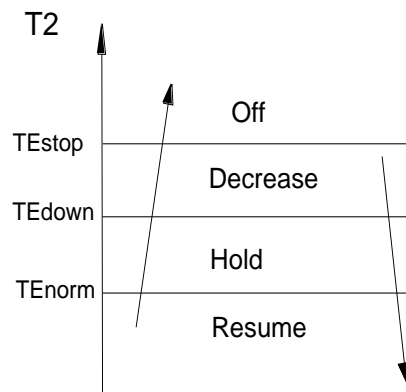

Off: Compressor stops.

Decrease: Decrease the running frequency to the lower level.

Hold: Keep the current frequency.

Resume: No limitation for frequency.

9.4.4 Auto-mode

This mode can be chosen with remote controller and the setting temperature can be changed between 17~30°C.

In auto mode, the machine will choose cooling, heating or fan-only mode according to ΔT ($\Delta T = T1 - Ts$).

$\Delta T = T1 - Ts$	Running mode
$\Delta T > 1^\circ\text{C}$	Cooling
$-1 < \Delta T \leq 1^\circ\text{C}$	Fan-only
$\Delta T \leq -1^\circ\text{C}$	Heating

Indoor fan will run at auto fan of the relevant mode.

The louver operates same as in relevant mode.

If the machine switches mode between heating and cooling, the compressor will keep stopping for 15 minutes and then choose mode according to T1-Ts.

If the setting temperature is modified, the machine will choose running function again.

9.4.5 Drying mode

9.4.5.1 Indoor fan speed is fixed at breeze and can't be changed. The louver angle is the same as in cooling mode.

9.4.5.2 Compressor running rules

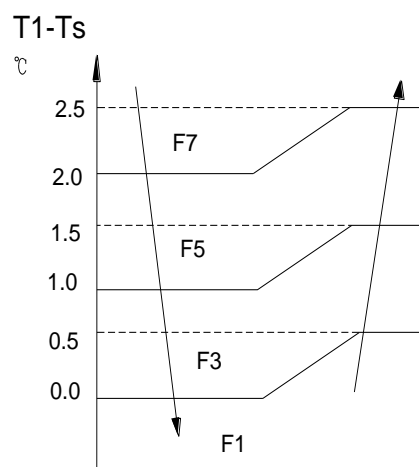

9.4.5.3 Low indoor room temperature protection

In drying mode, if room temperature is lower than 10°C, the compressor will stop and not resume until room temperature exceeds 12°C.

9.4.5.4 Evaporator anti-freezing protection, condenser high temperature protection and outdoor unit frequency limit are active and the same as that in cooling mode.

9.4.5.5 The outdoor fan operates the same as in cooling mode.

9.4.6 Forced operation function

9.4.6.1 Enter forced operation function:

When the machine is off, pressing the touch button will carry the machine to forced auto mode. If pressing the button once again within 5 seconds, the machine will turn into forced cooling mode. In forced auto, forced cooling or any other operation mode, pressing touch button will turn off the machine.

9.4.6.2 In forced operation mode, all general protections and remote control are available.

9.4.6.3 Operation rules:

Forced cooling mode:

The compressor runs at F2 frequency and indoor fan runs as breeze. After running for 30 minutes, the machine will turn to auto mode as 24°C setting temperature.

Forced auto mode:

The action of forced auto mode is the same as normal auto mode with 24°C setting temperature.

9.4.7 Timer function

9.4.7.1 Timing range is 24 hours.

9.4.7.2 Timer on. The machine will turn on automatically when reaching the setting time.

9.4.7.3 Timer off. The machine will turn off automatically when reaching the setting time.

9.4.7.4 Timer on/off. The machine will turn on automatically when reaching the setting "on" time, and then turn off automatically when reaching the setting "off" time.

9.4.7.5 Timer off/on. The machine will turn off automatically when reaching the setting "off" time, and then turn on automatically when reaching the setting "on" time.

9.4.7.6 The timer function will not change the AC current operation mode. Suppose AC is off now, it will not start up firstly after setting the "timer off" function. And when reaching the setting time, the timer LED will be off and the AC running mode has not been changed.

9.4.7.7 The setting time is relative time.

9.4.8 Sleep function mode

9.4.8.1 Operation time in sleep mode is 7 hours. After 7 hours the AC quits this mode and turns off.

9.4.8.2. Operation process in sleep mode is as follow:

When cooling, the setting temperature rises 1°C (be lower than 30°C) every one hour, 2 hours later the setting temperature stops rising and indoor fan is fixed as low speed.

When heating, the setting temperature decreases 1°C (be higher than 17°C) every one hour, 2 hours later the setting temperature stops rising and indoor fan is fixed as low speed. (Anti-cold wind function has the priority)

9.4.8.3 Timer setting is available

9.4.8.4 When user uses timer off function in sleep mode (or sleep function in timer off mode), if the timing is less than 7 hours, sleep function will be cancelled when reaching the setting time. If the timing is more than 7 hours, the machine will not stop until reaches the setting time in sleep mode.

9.4.9 Auto-Restart function

The indoor unit is equipped with auto-restart function, which is carried out through an auto-restart module. In case of a sudden power failure, the module memorizes the setting conditions before the power failure. The unit will resume the previous operation setting (not including swing function) automatically after 3 minutes when power returns.

If the memorization condition is forced cooling mode, the unit will run in cooling mode for 30 minutes and turn to auto mode as 24°C setting temp.

If AC is off before power off and AC is required to start up now, the compressor will have 1 minute delay when power on. Other conditions, the compressor will have 3 minutes delay when restarts.

9.4.10 8°C Heating

In heating operation, the preset temperature of the air conditioner can be as lower as 8°C, which keeps the room temperature steady at 8°C and prevents household things freezing when the house is unoccupied for a long time in severe cold weather.

9.4.11 Follow me

1) If the indoor PCB receives the signal which results from pressing the FOLLOW ME button on

ELECTRONIC FUNCTION

remote controller, the buzzer will emit a sound and this indicates the follow me function is initiated. But when the indoor PCB receives signal which sent from remote controller every 3 minutes, the buzzer will not respond. When the unit is running with follow me function, the PCB will control the unit according to the temperature from follow me signal, and the temperature collection function of room temperature sensor will be shielded, but the error detective function of room temperature sensor will be still valid.

- 2) When the follow me function is available, the PCB will control the unit according to the room temperature from the remote controller and the setting temperature.
- 3) The PCB will take action to the mode change information from remote controller signal, but it will not be affected by the setting temperature.
- 4) When the unit is running with follow me function, if the PCB doesn't receive any signal from remote controller for 7 minutes or pressing FOLLOW ME button again, the follow me function will be turned off automatically, and the temperature collection function of room temperature sensor will be available, the PCB will control the unit according to the room temperature detected from its own room temperature sensor and setting temperature.

9.4.12 Self clean

For heat pump models which are provided with this function, after running in cooling or drying mode, if the user press "Self Clean" button on remote controller, firstly, indoor unit runs in fan only mode for a while, then low heat operation and finally runs in fan only again. This function can keep the inside of indoor unit dry and prevent breeding of mold.

9.4.13 Refrigerant Leakage Detection

With this new technology, the display area will show "EC" when the outdoor unit detects refrigerant leakage.

9.4.14 Louver Position Memory Function

When starting the unit again after shutting down, its louver will restore to the angle originally set by the user, but the precondition is that the angle must be within the allowable range, if it exceeds, it will memorize the maximum angle of the louver. During operation, if the power fails or the end user shuts down the unit in the turbo mode, the louver will restore to the default angle.

9.4.16 Silence operation

Press the "silence" button on remote controller to initiate SILENCE function. When the Silence function is activated, the compressor running frequency will keep lower than F2 and the indoor unit will bring faint breeze, which will reduce the noise to the lowest level and create a quiet and comfortable room for you.

9.4.17 Frequency limitation protection

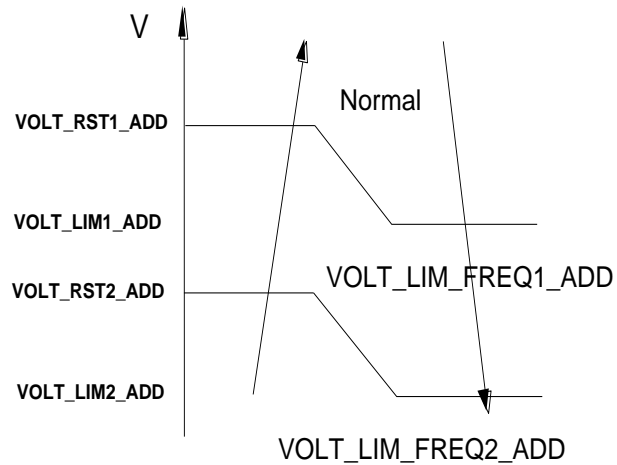

The PCB will detect the voltage of power supply and adjust the compressor running frequency to protect the system.

In the first 10 seconds after power on, this protection is inactive.

When this protection happens, it will last 3 minutes and then the PCB will detect the power supply voltage again.

10.1 Indoor Unit Error Display

Operation lamp	Timer lamp	Display	LED STATUS
☆ 1 time	X	E0	Indoor unit EEPROM parameter error
☆ 2 times	X	E1	Indoor / outdoor units communication error
☆ 3 times	X	E2	Zero crossing signal detection error (only for AWSI-HND024-N11)
☆ 4 times	X	E3	Indoor fan speed has been out of control
☆ 5 times	X	E4	Indoor room temperature sensor T1 open circuit or short circuit
☆ 6 times	X	E5	Evaporator coil temperature sensor T2 open circuit or short circuit
☆ 7 times	X	EC	Refrigerant Leakage Detection
☆ 2 times	O	F1	Outdoor ambient temperature sensor T4 open circuit or short circuit
☆ 3 times	O	F2	Condensercoil temperature sensor T3 open circuit or short circuit
☆ 4 times	O	F3	Compressor discharge temperature sensor T5 open circuit or short circuit
☆ 5 times	O	F4	Outdoor unit EEPROM parameter error
☆ 6 times	O	F5	Outdoor fan speed has been out of control
☆ 1 times	☆	P0	IPM malfunction or IGBT over-strong current protection
☆ 2 times	☆	P1	Over voltage or over low voltage protection
☆ 3 times	☆	P2	High temperature protection of compressor top diagnosis and solution (Only for AWSI-HND018-N11)
☆ 5 times	☆	P4	Inverter compressor drive error

O (light) X (off) ☆ (flash)

10.2 Diagnosis and Solution

10.2.1 EEPROM parameter error diagnosis and solution(E0)

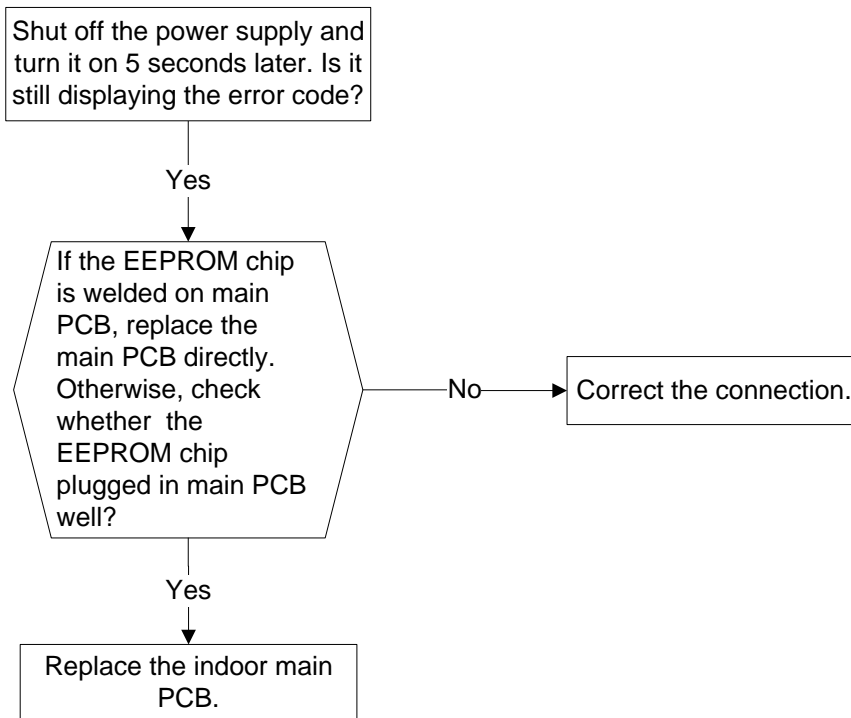

EEPROM: a read-only memory whose contents can be erased and reprogrammed using a pulsed voltage.

10.2.2 Indoor unit and outdoor unit communication protection error diagnosis and solution(E1)

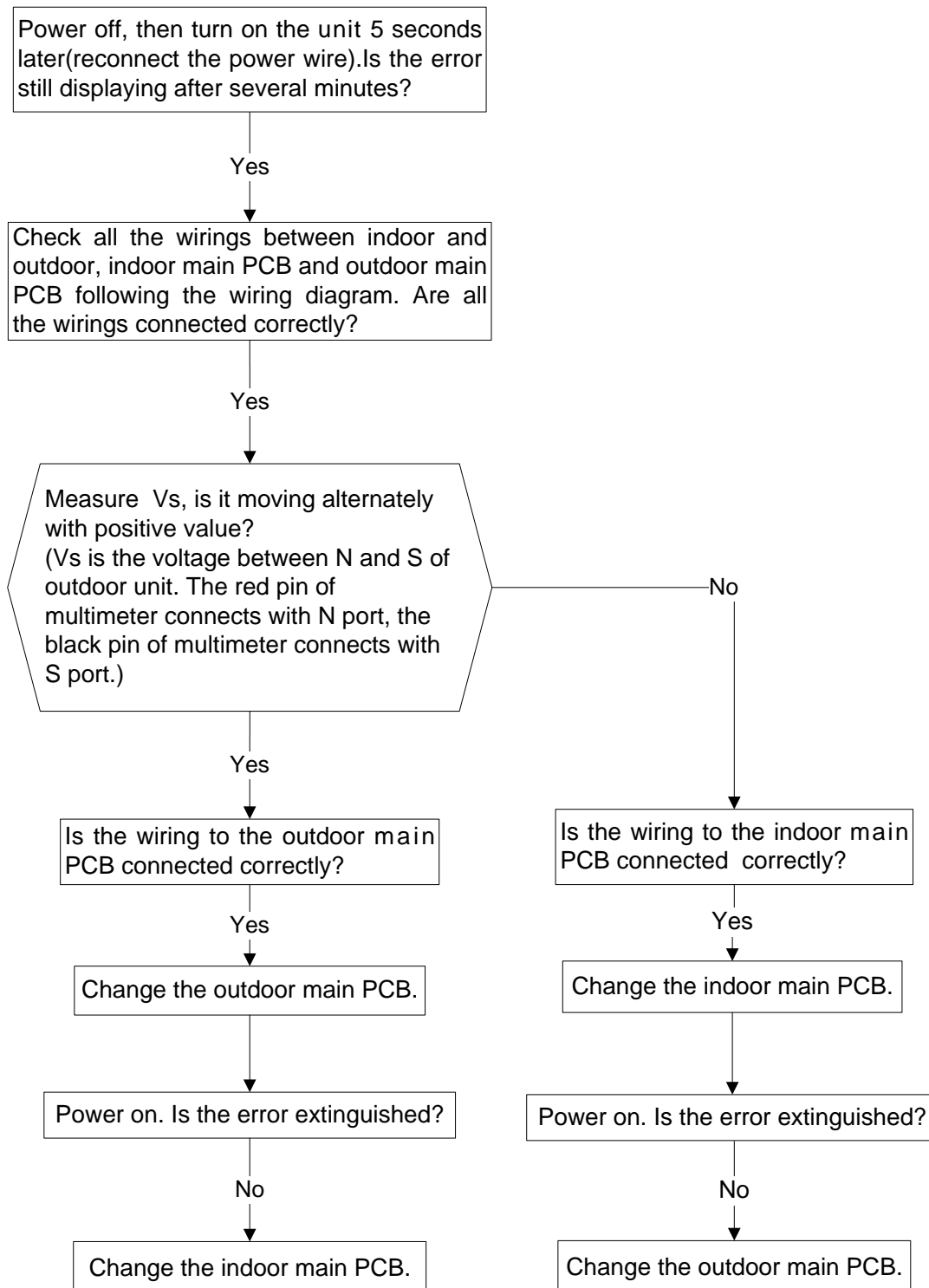

10.2.3 Zero crossing detection error diagnosis and solution (E2)

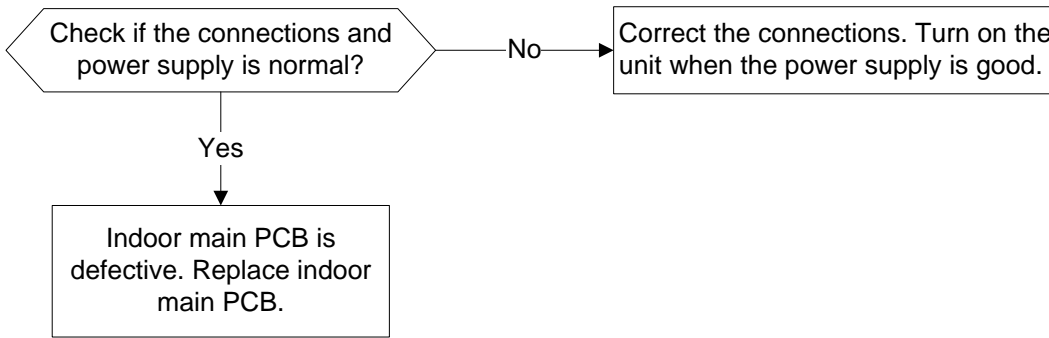

10.2.4 Fan speed has been out of control diagnosis and solution (E3/F5)

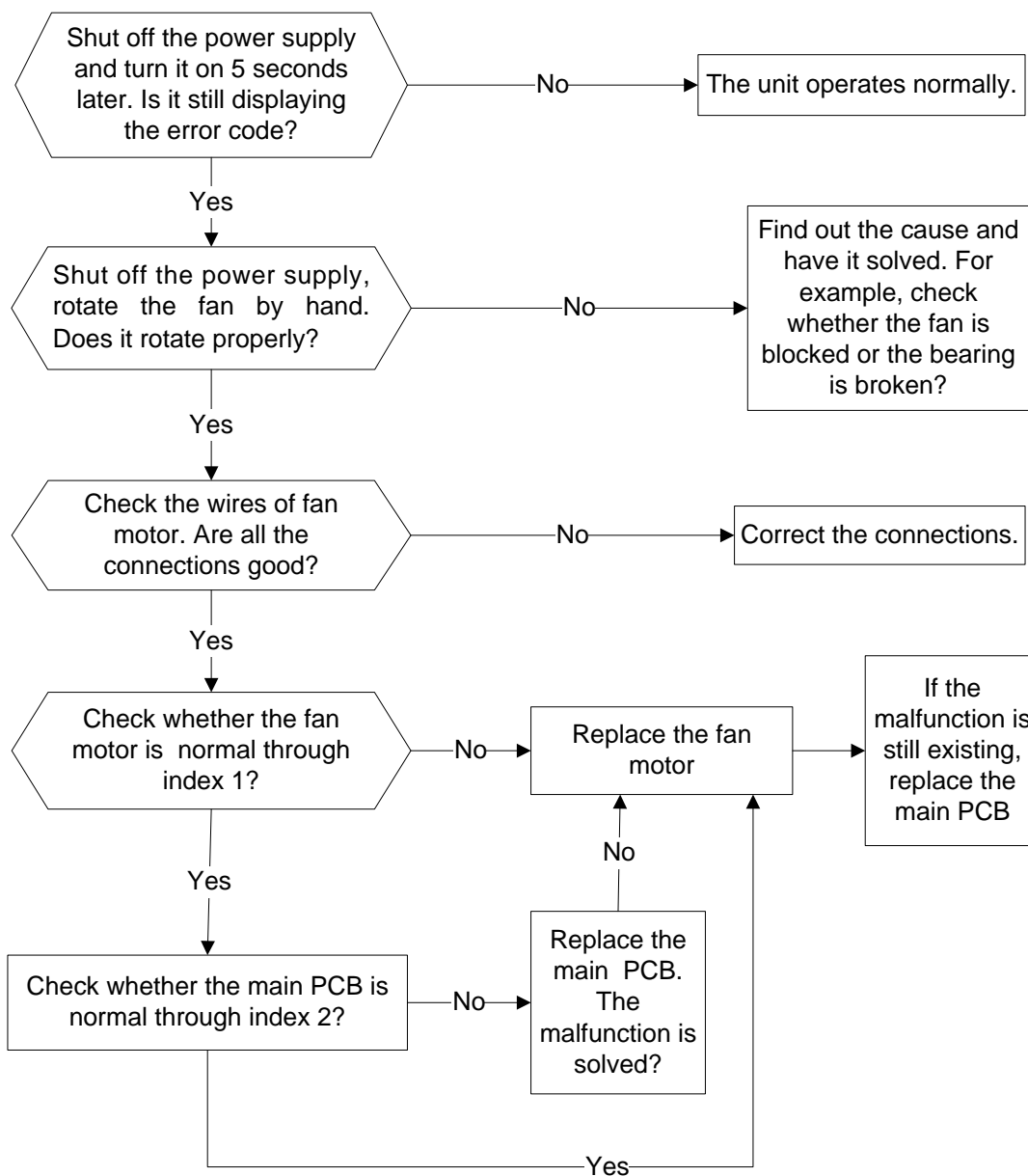

TROUBLESHOOTING

Index 1:

1. Indoor or Outdoor DC Fan Motor(control chip is in fan motor)

Measure the resistance value of each winding by using the tester. If any resistance value is zero, the fan motor must have problems and need to be replaced.

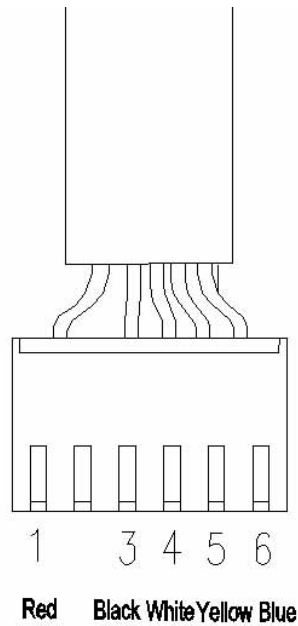

2. Indoor AC Fan Motor

Measure the resistance value of each winding by using the tester.

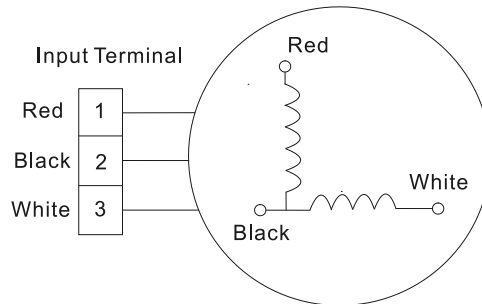

Position	Resistance Value	
	RPG50C	
Black - Red	110Ω±8% (20℃) (Brand: Weiling)	123Ω±8% (20℃) (Brand: Dayang)
White - Black	93Ω±8% (20℃) (Brand: Weiling)	99Ω±8% (20℃) (Brand: Dayang)

3. OutdoorDC Fan Motor (control chip is in outdoor PCB)

For WZDK36-38G-W:

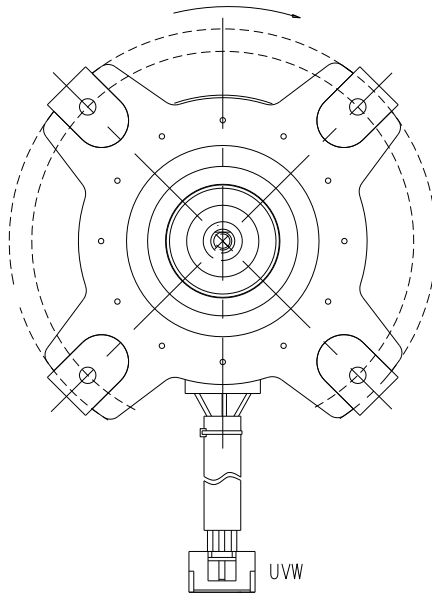

- 1) Release the UVW connector. Measure the resistance of U-V, U-W, V-W. If the resistance is not equal to each other, the fan motor must have problems and need to be replaced. Otherwise, go to step 2.

Index2:

1: Indoor or Outdoor DC Fan Motor (control chip is in fan motor)

Power on and when the unit is in standby, measure the voltage of pin1-pin3, pin4-pin3 in fan motor connector. If the value of the voltage is not in the range showing in below table, the PCB must have problems and need to be replaced.

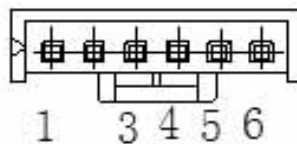

DC motor voltage input and output

NO.	Color	Signal	Voltage
1	Red	Vs/Vm	280V~380V
2	---	---	---
3	Black	GND	0V
4	White	Vcc	14-17.5V
5	Yellow	Vsp	0~5.6V
6	Blue	FG	14-17.5V

TROUBLESHOOTING

2. Indoor AC Fan Motor

Power on and set the unit running in fan mode at high fan speed. After running for 15 seconds, measure the voltage of pin1 and pin2. If the value of the voltage is less than 100V(208~240V power supply) or 50V(115V power supply), the PCB must have problems and need to be replaced.

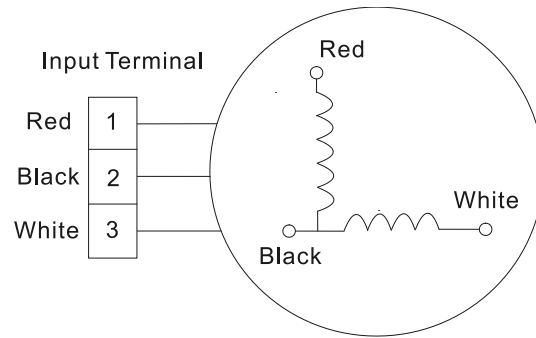

10.2.4 Open circuit or short circuit of temperature sensor diagnosis and solution

(E4/E5/F1/F2/F3)

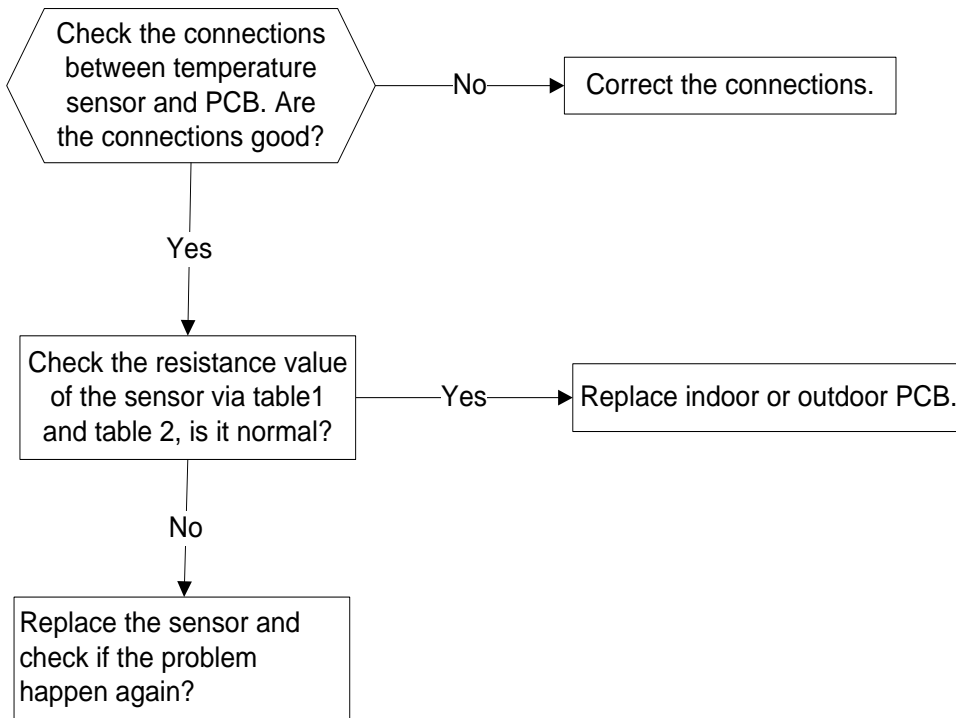

10.2.5 Refrigerant leakage detection diagnosis and solution (EC)

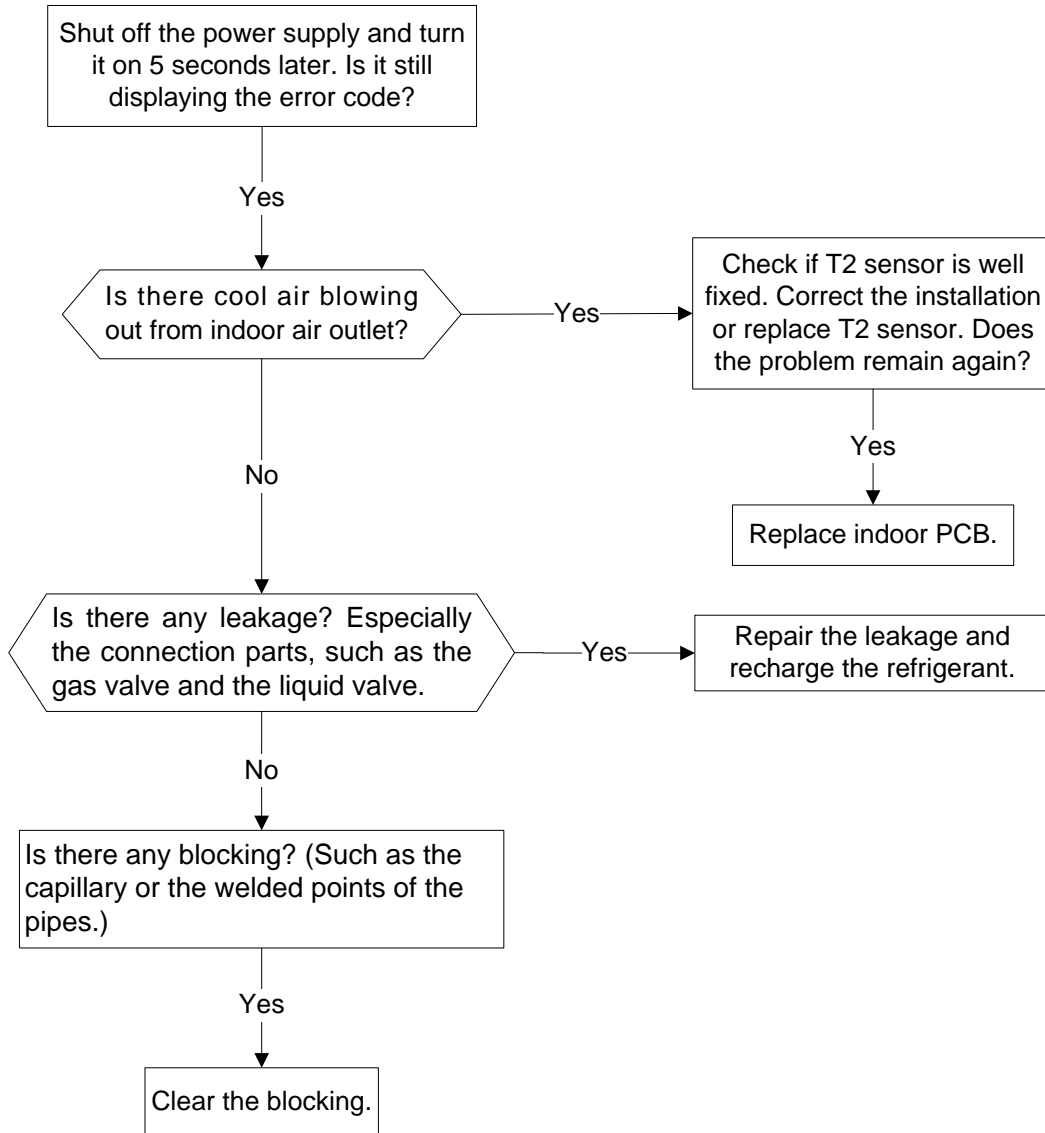

10.2.6 IPM malfunction or IGBT over-strong current protection diagnosis and solution(P0)

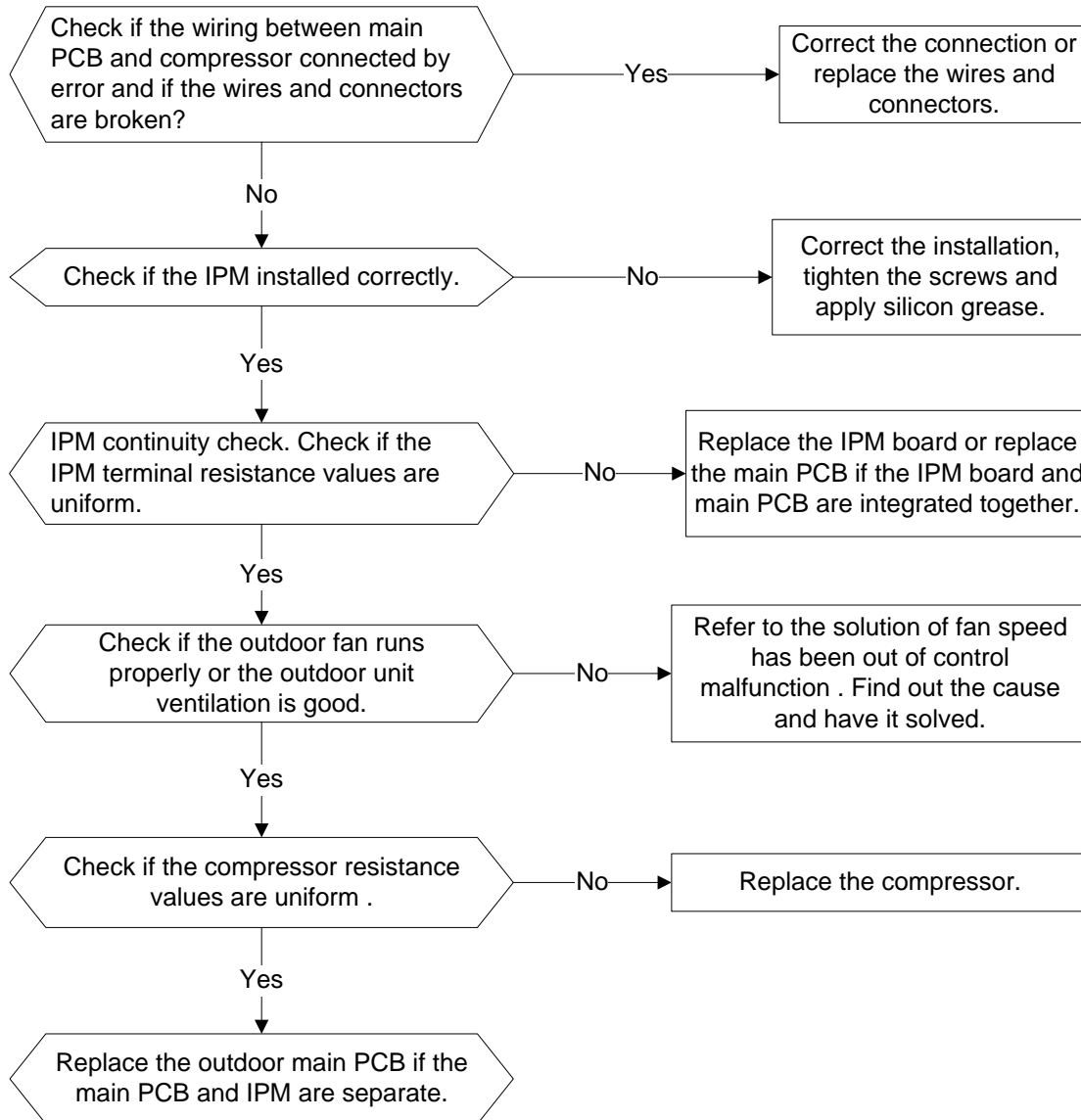

10.2.7 Over voltage or too low voltage protection diagnosis and solution(P1)

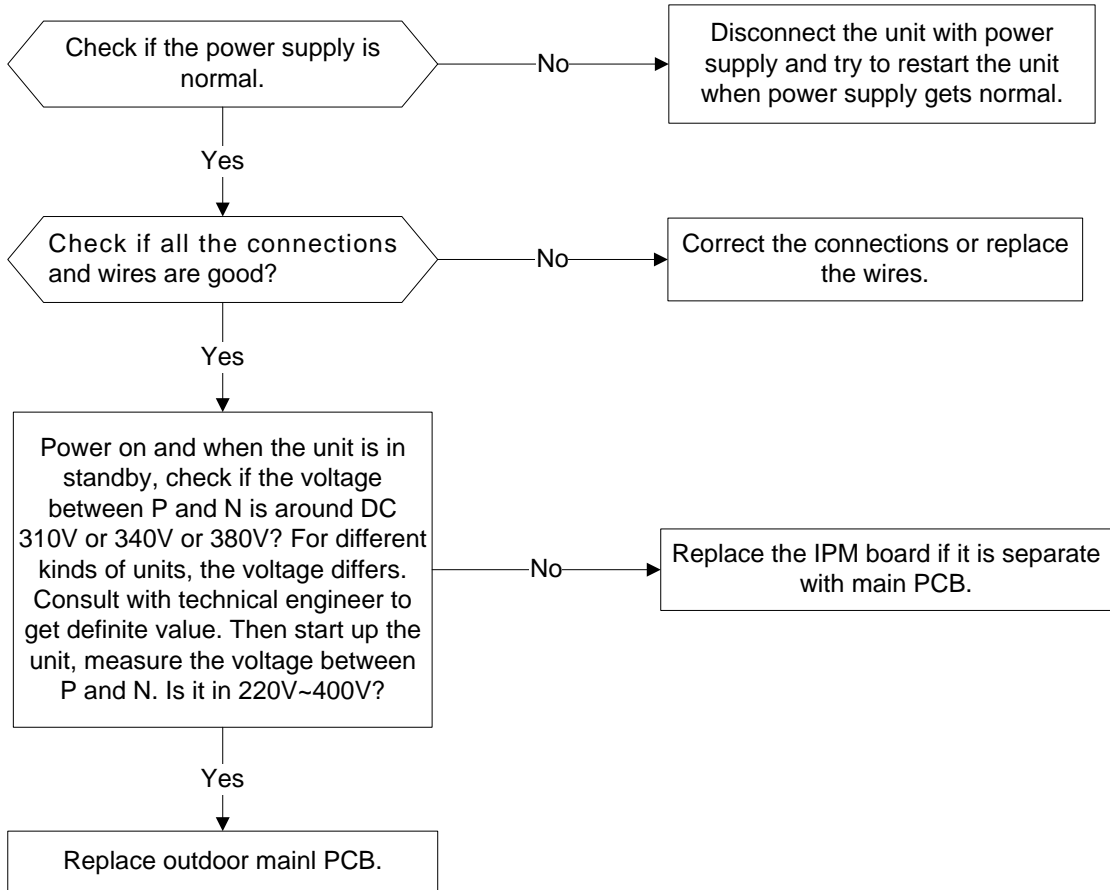

10.2.8 High temperature protection of compressor top diagnosis and solution(P2)

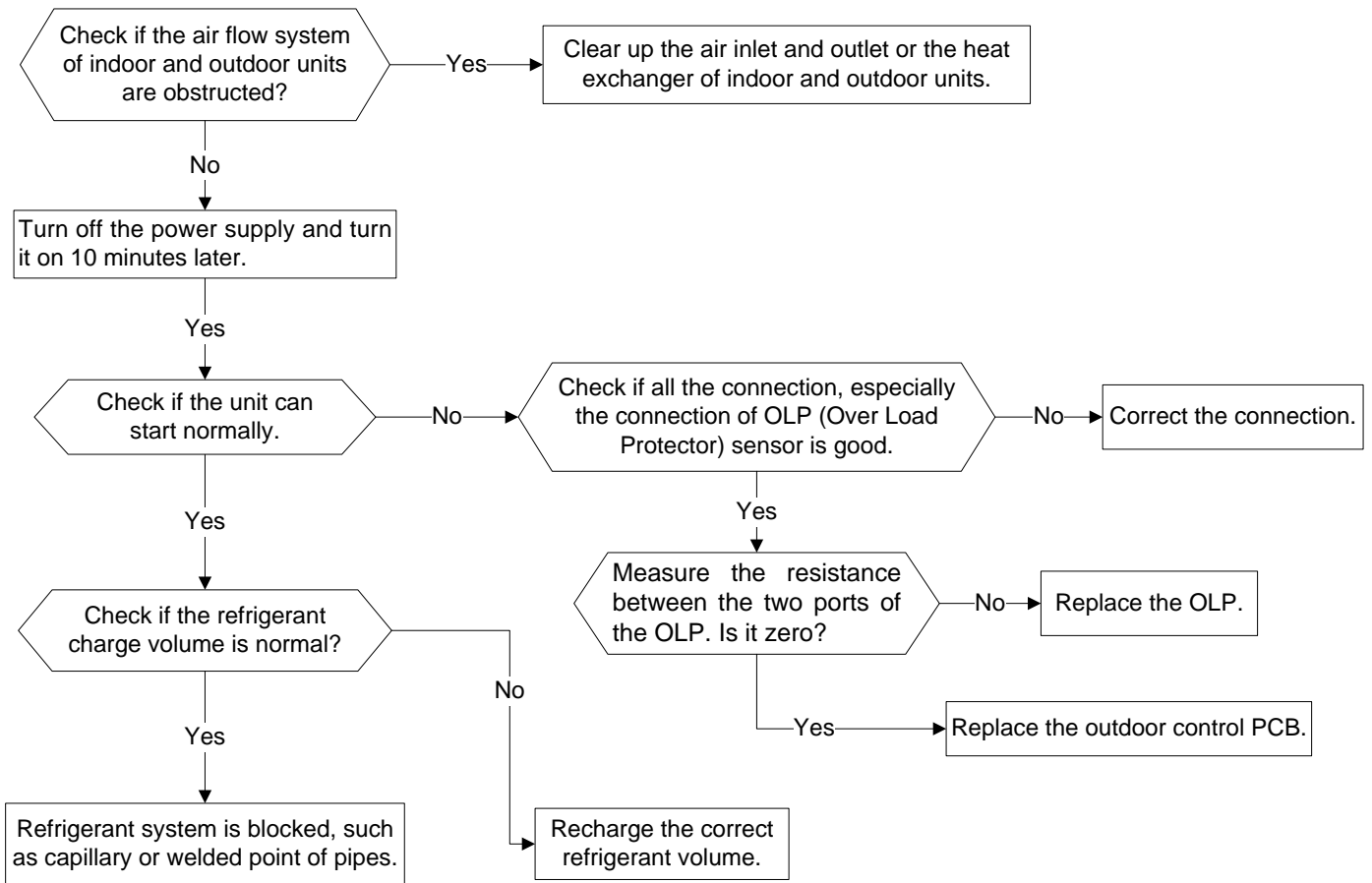

10.2.9 Inverter compressor drive error diagnosis and solution(P4)

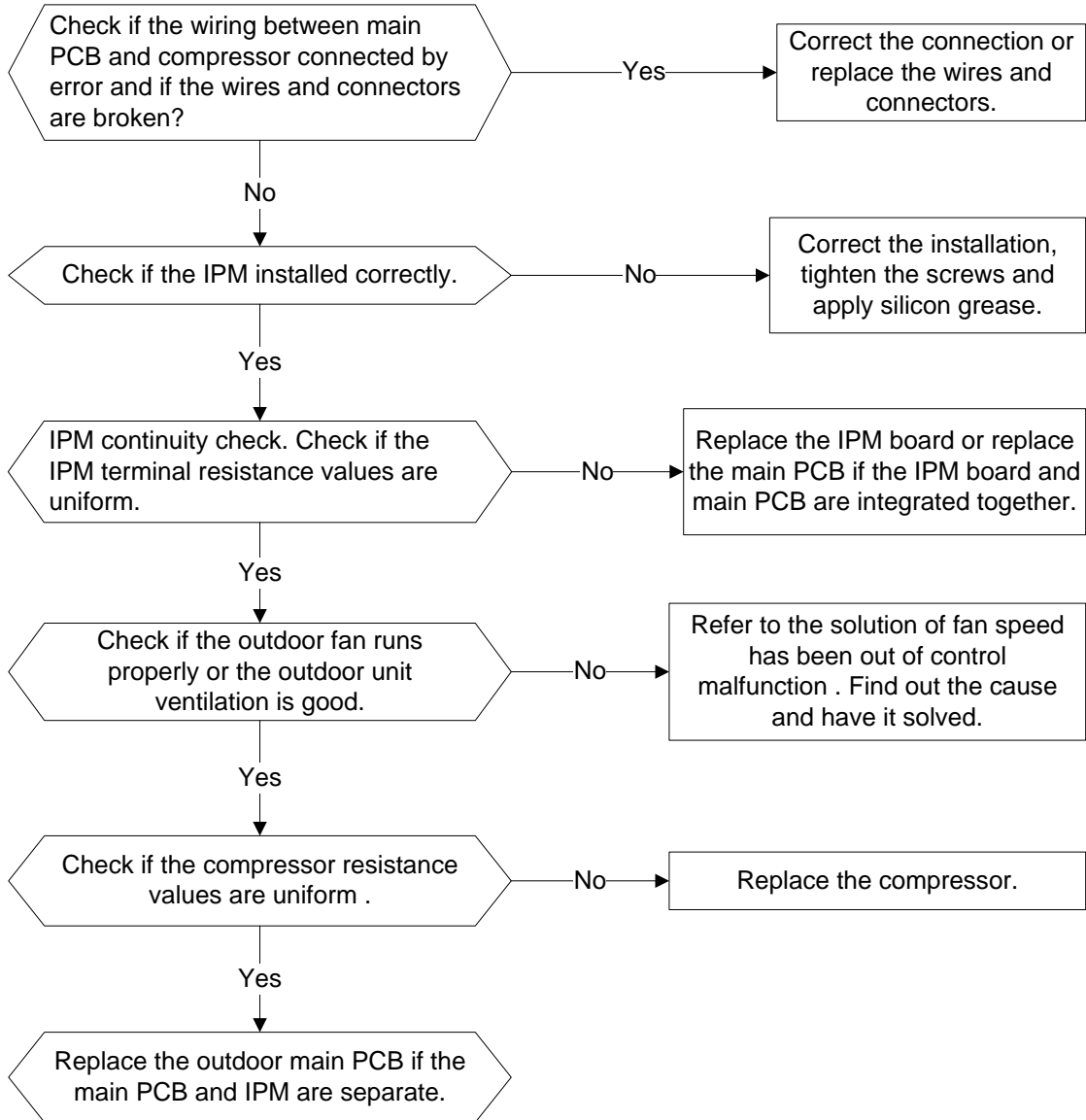

Safety

Electricity power is still kept in capacitors even the power supply is shut off. Do not forget to discharge the electricity power in capacitor.

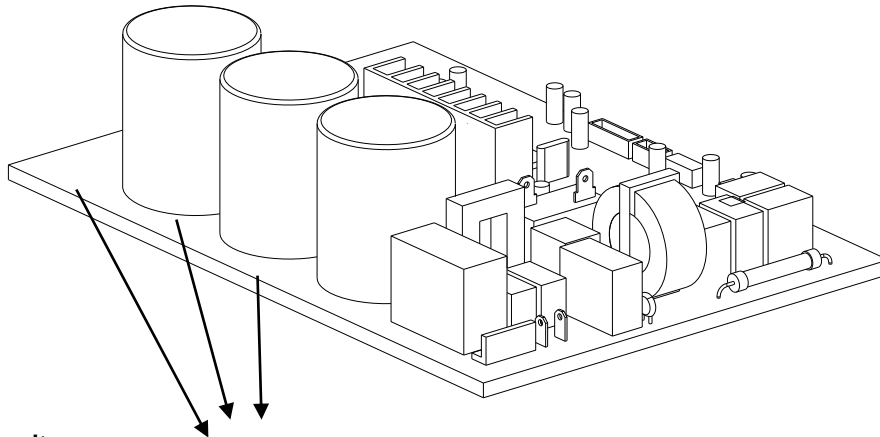

Electrolytic Capacitors

(HIGH VOLTAGE! CAUTION!)

Connect discharge resistance (approx. 100Ω 40W) or soldering iron (plug) between +, - terminals of the electrolytic capacitor on the contraryside of the outdoor PCB.

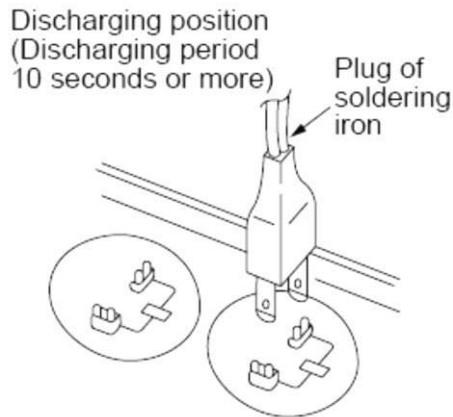

Note: The picture above is only for reference. The plug of your side may be different.

Main parts check

1. Temperature sensor checking

Disconnect the temperature sensor from PCB, measure the resistance value with a tester.

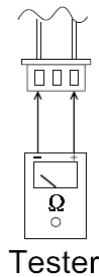

TROUBLESHOOTING

Temperature Sensors.

- Room temp.(T1) sensor,
- Indoor coil temp.(T2) sensor,
- Outdoor coil temp.(T3) sensor,
- Outdoor ambient temp.(T4) sensor,
- Compressor discharge temp.(T5) sensor.

Measure the resistance value of each winding by using the multi-meter.

Table 1:Some frequently-used R-T data for T1,T2,T3 and T4 sensor:

Temperature (°C)	5	10	15	20	25	30	40	50	60
Resistance Value (KΩ)	26.9	20.7	16.1	12.6	10	8	5.2	3.5	2.4

Table 2:Some frequently-used R-T data for T5 sensor:

Temperature (°C)	5	15	25	35	60	70	80	90	100
Resistance Value (KΩ)	141.6	88	56.1	36.6	13.8	9.7	6.9	5	3.7

Resistance value (KΩ)

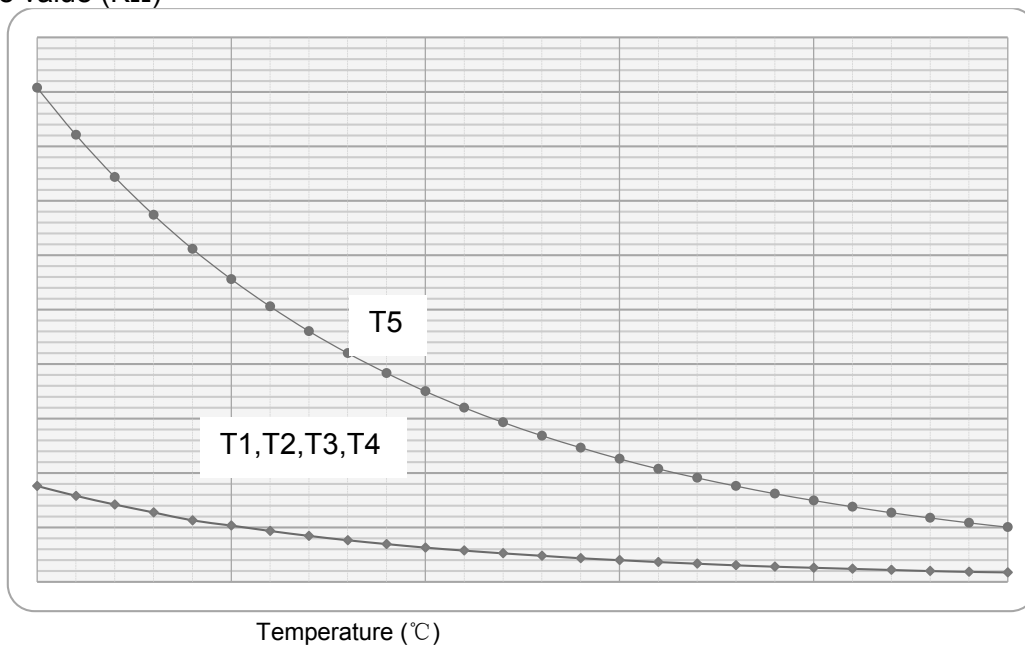

Spec.

Code	2T0032300900	2T0032500719	2T0032800708
Model	AWSI-HND009-N11	AWSI-HND012-N11	AWSI-HND018-N11
Compressor	ASN108D22UEZ	ASN108D22UEZ	DA150S1C-20FZ
Indoor fan motor	WZDK20-38G (☆)	WZDK20-38G (☆)	WZDK58-38G (☆)
Outdoor fan motor	WZDK36-38G-W (★)	WZDK36-38G-W (★)	WZDK35-38G(H) (★)

Code	2T0033000524
Model	AWSI-HND024-N11
Compressor	DA250S2C-30MT
Indoor fan motor	RPG50C
Outdoor fan motor	WZDK50-38G (☆)

Note: The motor marked “★” means DC fan motor with control chip in the PCB while the ones marked “☆” means DC fan motor with control chip in the fan motor.

TROUBLESHOOTING

2. Compressor checking

Measure the resistance value of each winding by using the tester.

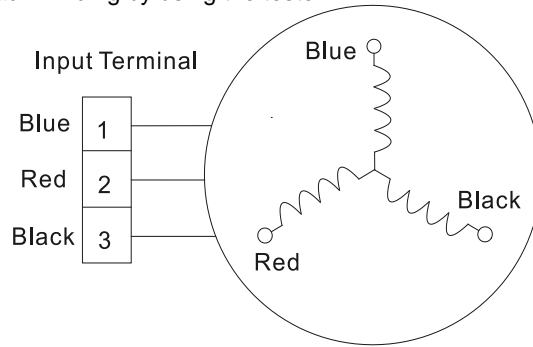

Position	Resistance Value		
	ASN108D22UEZ	DA150S1C-20FZ	DA250S2C-30MT
Blue - Red	1.5Ω (20°C)	0.95Ω (20°C)	0.55Ω (20°C)
Blue - Black			
Red - Blue			

3. IPM continuity check

Turn off the power, let the large capacity electrolytic capacitors discharge completely, and dismount the IPM. Use a digital tester to measure the resistance between P and UVWN; UVW and N.

Digital tester		Normal resistance value
(+)Red	(-)Black	
P	N	∞ (Several MΩ)
	U	
	V	
	W	

Digital tester		Normal resistance value
(+)Red	(-)Black	
U	N	∞ (Several MΩ)
V		
W		

11. Exploded View

11.1 Indoor unit

AWSI-HND009-N11:

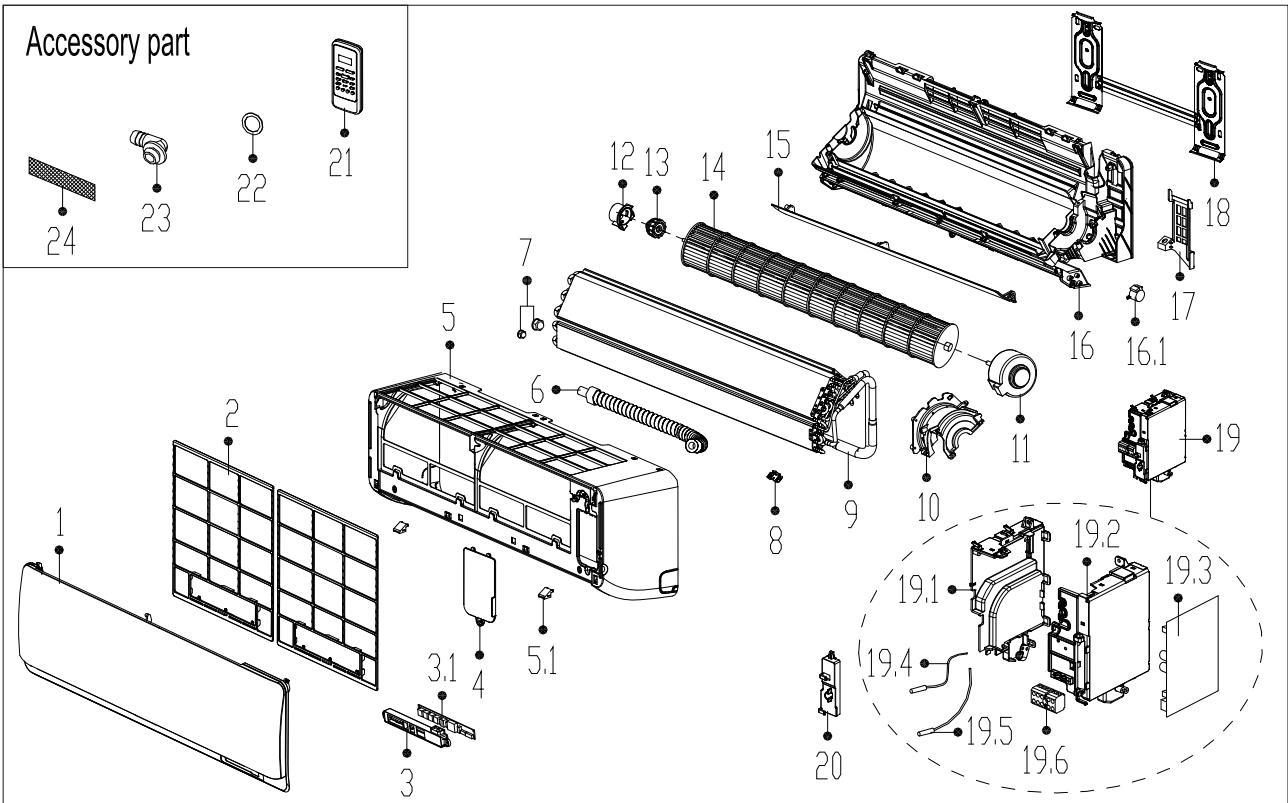

No.	BOM Code	Part Name	Quantity
1	2011323A3829	Panel assembly	1
2	201132391052	Air filter	2
3	2033323A2544	Display box assembly	1
3.1	2013330A0830	Display board assembly	1
4	201119901024	Cover of electrical equipment	1
5	201132392602	Panel frame assembly	1
5.1	201119900950	Screw cap	2
6	201101020038	Drain hose	1
7	201600320001	Pipe nut	1
7	201600320000	Pipe nut	1
8	201102000305	Fix clamp of temperature sensor	1
9	201532390212	Evaporator assembly	1
10	201132490127	Fan motor cover	1
11	202400370025	Brushless DC Motor	1
12	201119900952	Bearing holder	1
13	202719900606	Bearing base	1
14	201100200055	Cross flow fan	1
15	201132391053	Horizontal louver	1
16	201132391058	Chassis assembly	1
16.1	202400200031	Louver motor	1
17	201119900949	Pipe clamp board	1
18	201232590037	Installation plate	1
19	17222000A09671	Electrical Control Box Subassembly	1
19.1	12122000004586	Electrical Control Box	1
19.2	12122000009440	Electrical Control Box	1
19.3	17122000A09899	Indoor Main Control Board Subassembly	1
19.4	202433190000	Ambient temperature sensor assembly	1
19.5	202301300426	Pipe temperature sensor assembly	1
19.6	17400401A00046	Wire holder	1
20	201132490126	Cover of electronic control box	1
21	203355091552	Remote Controller	1
22	202720090001	Seal ring	1
23	201101020011	Drain joint	1
24	201131410703	Anti-bacterial filter	1
	201130100273	Nano photocatalysis filter	1
	202319900113	ESF	1

EXPLODED VIEW

AWSI-HND012-N11:

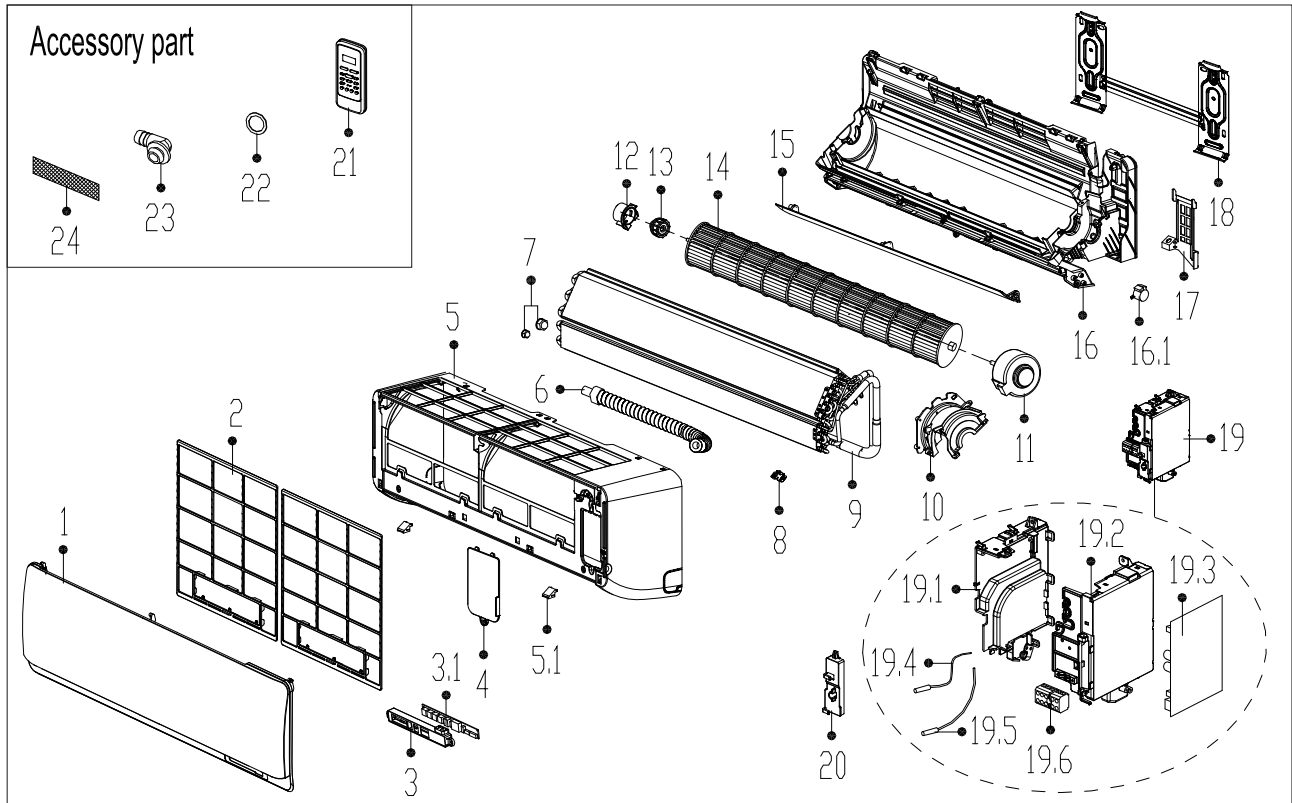

No.	BOM Code	Part Name	Quantity
1	2011325A5384	Panel assembly	1
2	201132590962	Air filter	2
3	2033323A2544	Display box assembly	1
3.1	2013330A0830	Display board assembly	1
4	201119901024	Cover of electrical equipment	1
5	201132591059	Panel frame assembly	1
5.1	201119900950	Screw cap	2
6	201101020038	Drain hose	1
7	201600320001	Pipe nut	1
7	201600320000	Pipe nut	1
8	201102000305	Fix clamp of temperature sensor	1
9	201532590453	Evaporator assembly	1
10	201132490127	Fan motor cover	1
11	202400370025	Brushless DC Motor	1
12	201119900952	Bearing holder	1
13	202719900606	Bearing base	1
14	201100200054	Cross flow fan	1
15	201132590956	Horizontal louver	1
16	201132590963	Chassis assembly	1
16.1	202400200031	Louver motor	1
17	201119900949	Pipe clamp board	1
18	201232590037	Installation plate	1
19	17222000A09674	Electrical Control Box Subassembly	1
19.1	12122000004586	Electrical Control Box	1
19.2	12122000009440	Electrical Control Box	1
19.3	17122000A09903	Indoor Main Control Board Subassembly	1
19.4	202433190000	Ambient temperature sensor assembly	1
19.5	202301300426	Pipe temperature sensor assembly	1
19.6	17400401A00046	Wire holder	1
20	201132490126	Cover of electronic control box	1
21	203355091552	Remote Controller	1
22	202720090001	Seal ring	1
23	201101020011	Drain joint	1
24	201131410703	Anti-bacterial filter	1
	201130100273	Nano photocatalysis filter	1
	202319900113	ESF	1

EXPLODED VIEW

AWSI-HND018-N11:

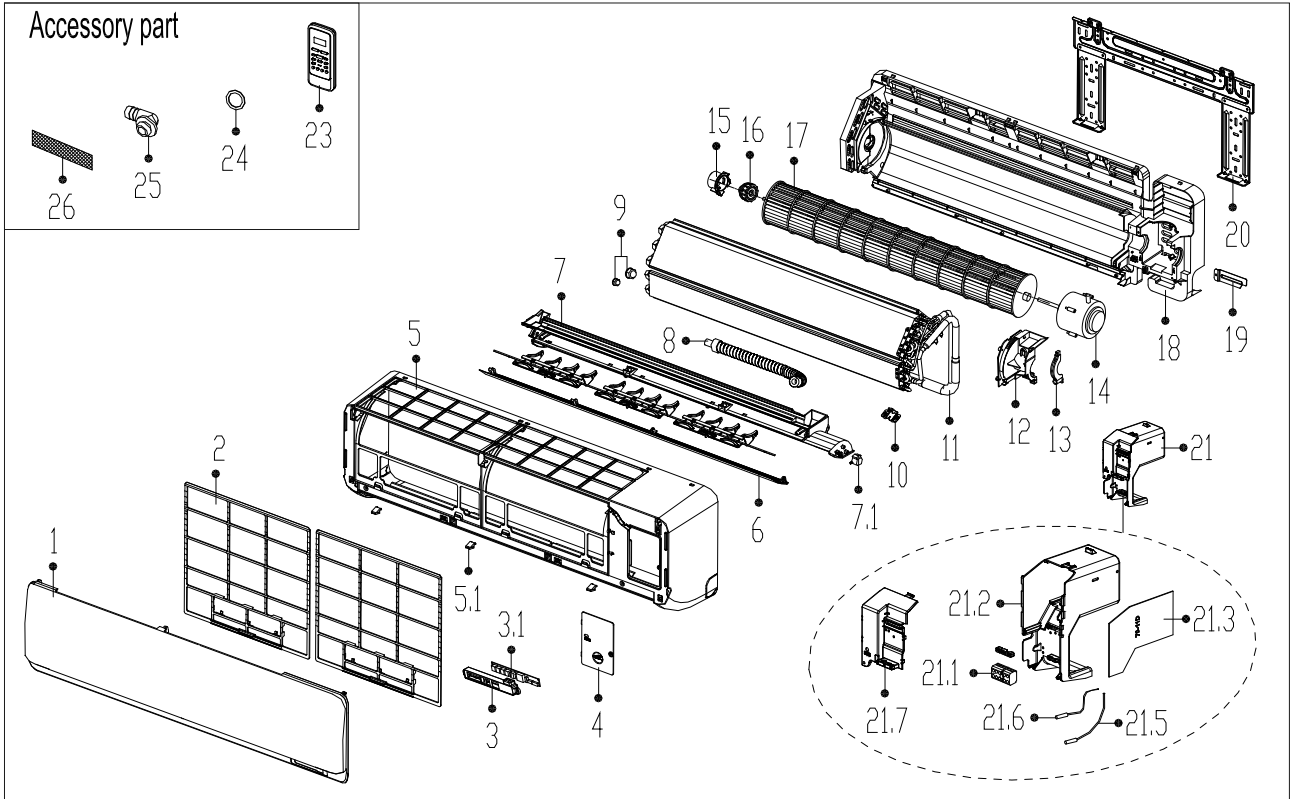

No.	BOM Code	Part Name	Quantity
1	2011328A2355	Panel assembly	1
2	201132890670	Air filter	2
3	2033327A0877	Display box assembly	1
3.1	2013330A0830	Display board assembly	1
4	201133091048	Cover of electrical equipment	1
5	201132890673	Panel frame assembly	1
5.1	201119900950	Screw cap	3
6	201132890671	Horizontal louver	1
7	2011328A1649	Air outlet assembly	1
7.1	202400200120	Louver motor	1
8	201101020038	Drain hose	1
9	201600320000	Pipe nut	1
9	201600320002	Pipe nut	1
10	201102000305	Fix clamp of temperature sensor	1
11	201532890153	Evaporator assembly	1
12	201133090980	Fan motor cover	1
13	201133090167	Fixing board of fan motor	1
14	202400300064	Brushless DC Motor	1
15	201119900952	Bearing holder	1
16	202719900606	Bearing base	1
17	201100200056	Cross flow fan	1
18	201132890703	Chassis assembly	1
19	201232800103	Pipe clamp board	1
20	201232590038	Installation plate	1
21	17222000A09672	Electrical Control Box Subassembly	1
21.1	17400401000032	Wire holder	1
21.2	12122000009480	Electrical Control Box	1
21.3	17122000A09901	Indoor Main Control Board Subassembly	1
21.5	202432390005	Ambient temperature sensor assembly	1
21.6	202301300584	Pipe temperature sensor assembly	1
21.7	12122000009481	Electrical Control Box Cover	1
23	203355091552	Remote Controller	1
24	202720090001	Seal ring	1
25	201101020011	Drain joint	1
26	201131410703	Anti-bacterial filter	1
	201130100273	Nano photocatalysis filter	1
	202319900113	ESF	1

EXPLODED VIEW

AWSI-HND024-N11:

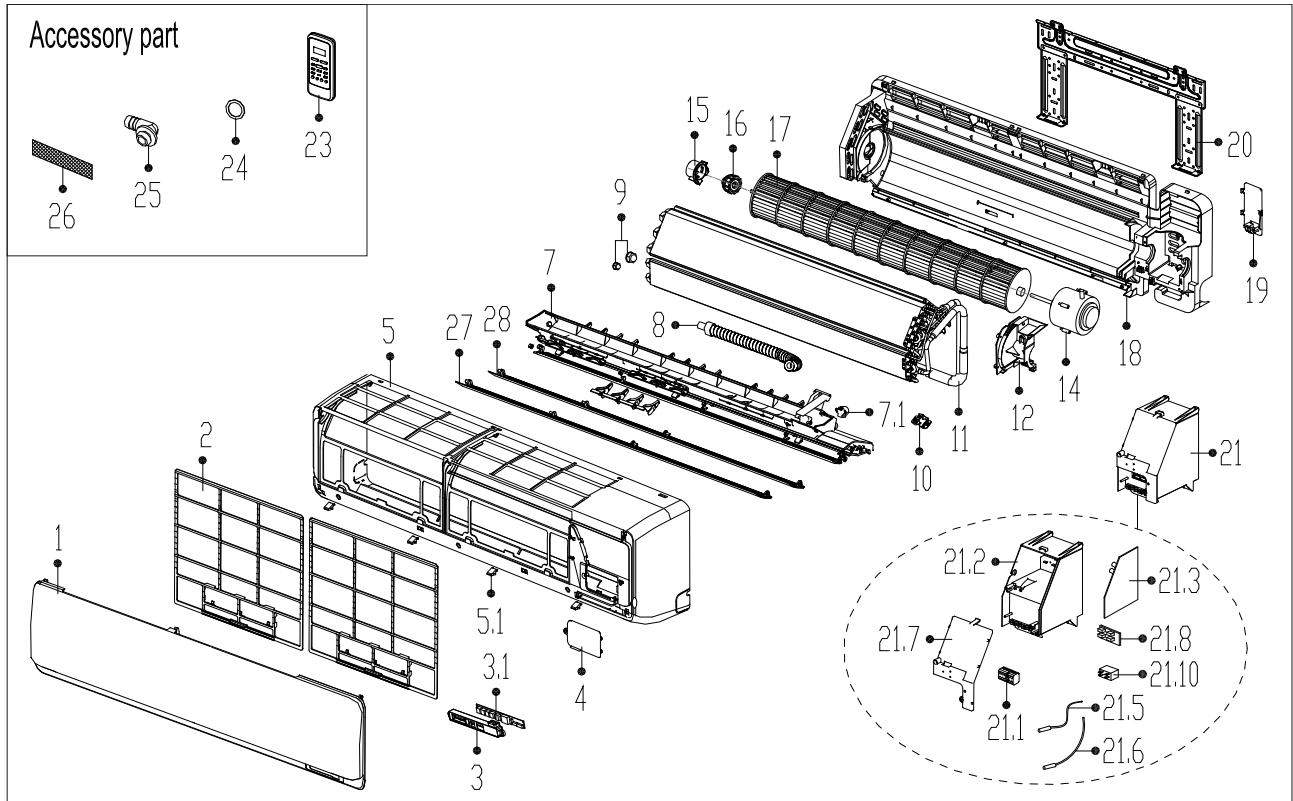

No.	BOM Code	Part Name	Quantity
1	2011330A5096	Panel assembly	1
2	201133090992	Air filter	2
3	2033330A0754	Display box assembly	1
3.1	2013330A0830	Display board assembly	1
4	201119901024	Cover of electrical equipment	1
5	201133090996	Panel frame assembly	1
5.1	201119900950	Screw cap	4
7	201133091008	Air outlet assembly	1
7.1	202400200070	Louver motor	1
8	201101020038	Drain hose	1
9	201600320003	Pipe nut	1
9	201600320001	Pipe nut	1
10	201102000305	Fix clamp of temperature sensor	1
11	201533090133	Evaporator assembly	1
12	201133090991	Fan motor cover	1
14	202400401266	Asynchronous motor	1
15	201119900952	Bearing holder	1
16	202719900606	Bearing base	1
17	201100200057	Cross flow fan	1
18	201133090995	Chassis assembly	1
19	201133090989	Pipe clamp board	1
20	201232990002	Installation plate	1
21	17222000A09303	Electrical Control Box Subassembly	1.0
21.1	17400401000032	Wire holder	1.0
21.2	12122000009485	Electrical Control Box	1.0
21.3	17122000A09691	Indoor Main Control Board Subassembly	1.0
21.5	202301300210	Ambient temperature sensor assembly	1
21.6	202301300426	Pipe temperature sensor assembly	1
21.7	12122000005040	Electrical Control Box Cover	1.0
21.8	17122000008083	Power Supply Module Subassembly	1.0
21.10	17400101000031	Capacitor	1.0
23	203355091552	Remote Controller	1
24	202720090001	Seal ring	1
25	201101020011	Drain joint	1
26	201131410703	Anti-bacterial filter	1
27	201133090993	Horizontal louver (above)	1
28	201133090999	Horizontal louver (below)	1
	201130100273	Nano photocatalysis filter	1
	202319900113	ESF	1

11.2 Outdoor unit

AWAU-YND009-H11:

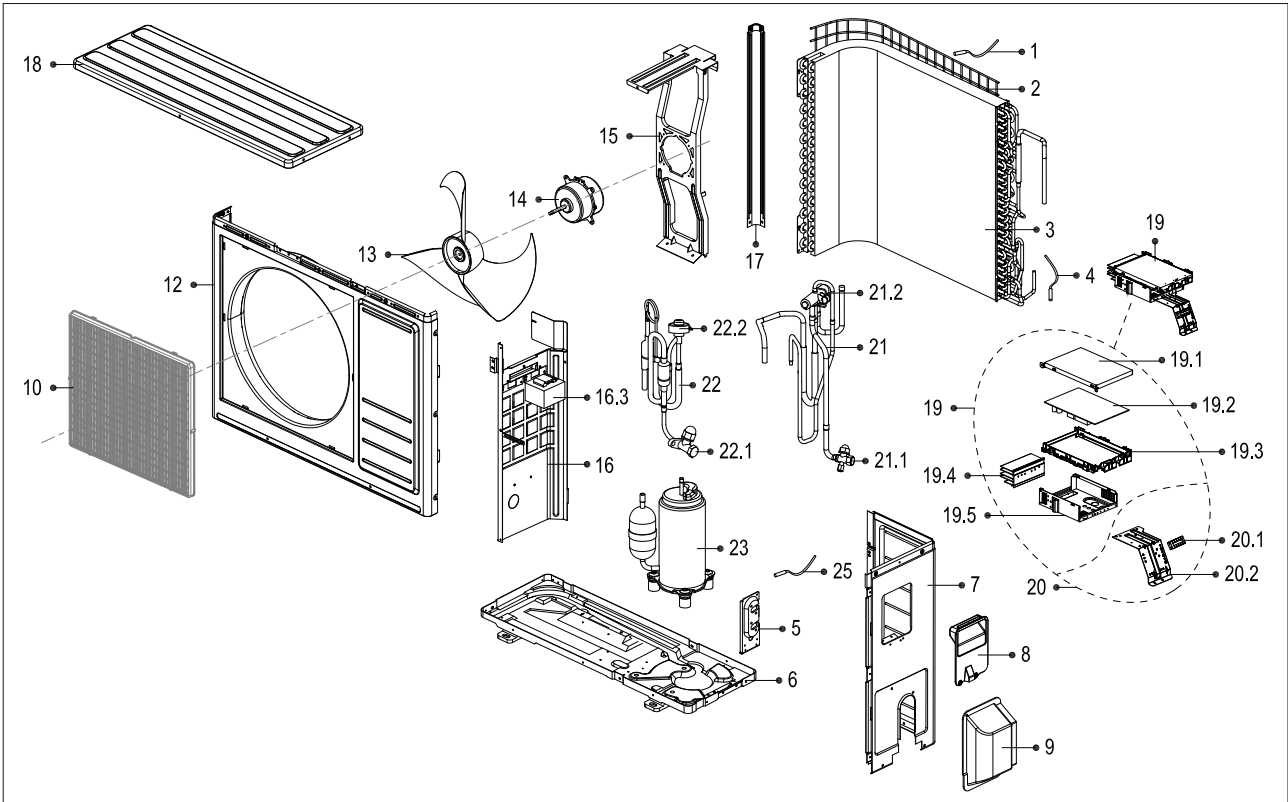

No.	BOM Code	Part Name	Quantity
1	202301300115	Ambient temperature sensor assembly	1
2	2011374G0003	Rear net	1
3	201537390033	Condenser assembly	1
4	202440500004	Pipe temperature sensor assembly	1
5	201237200299	Valve plate	1
6	201237590105	Chassis assembly	1
7	201237500263	Right clapboard assembly	1
8	201148100123	Big handle	1
9	201137400000	Water collector	1
10	2011374A0004	Air outlet grille	1
	2011374A0005	Round sticker of air outlet grille	1
12	201237400392	Front panel	1
13	201100390002	Axial flow fan	1
14	202400300536	Brushless DC Motor	1
15	201237390026	Supporter assembly of fan motor	1
16	201237500241	Partition board assembly	1
16.3	202301000867	Reactor	1
17	201237400400	Left supporter	1
18	201237900028	Top cover assembly	1
19	203337390267	Electronic control box assembly	1
19.1	201237300162	Cover of electronic control box	1
19.2	201337390241	Outdoor main control board assembly	1
19.3	201137300162	Support of electronic control box	1
19.4	202301990015	Radiator	1
19.5	201237300033	Electronic installing box	1
20	203337590135	Terminal board assembly	1
20.1	202301400015	Wire joint	1
20.2	201237590046	Terminal board	1
21	201637391703	4-Ways valve assembly	1
21.1	201600720095	Gas valve	1
21.2	201600600521	4-Ways valve	1
22	201637391551	Liquid valve assembly	1
22.1	201600740523	Liquid valve	1
22.2	201601300554	Electronic expansion valve assembly	1
23	201400611186	Compressor	1
25	202301310068	Discharge temperature sensor assembly	1

EXPLODED VIEW

AWAU-YND012-H11:

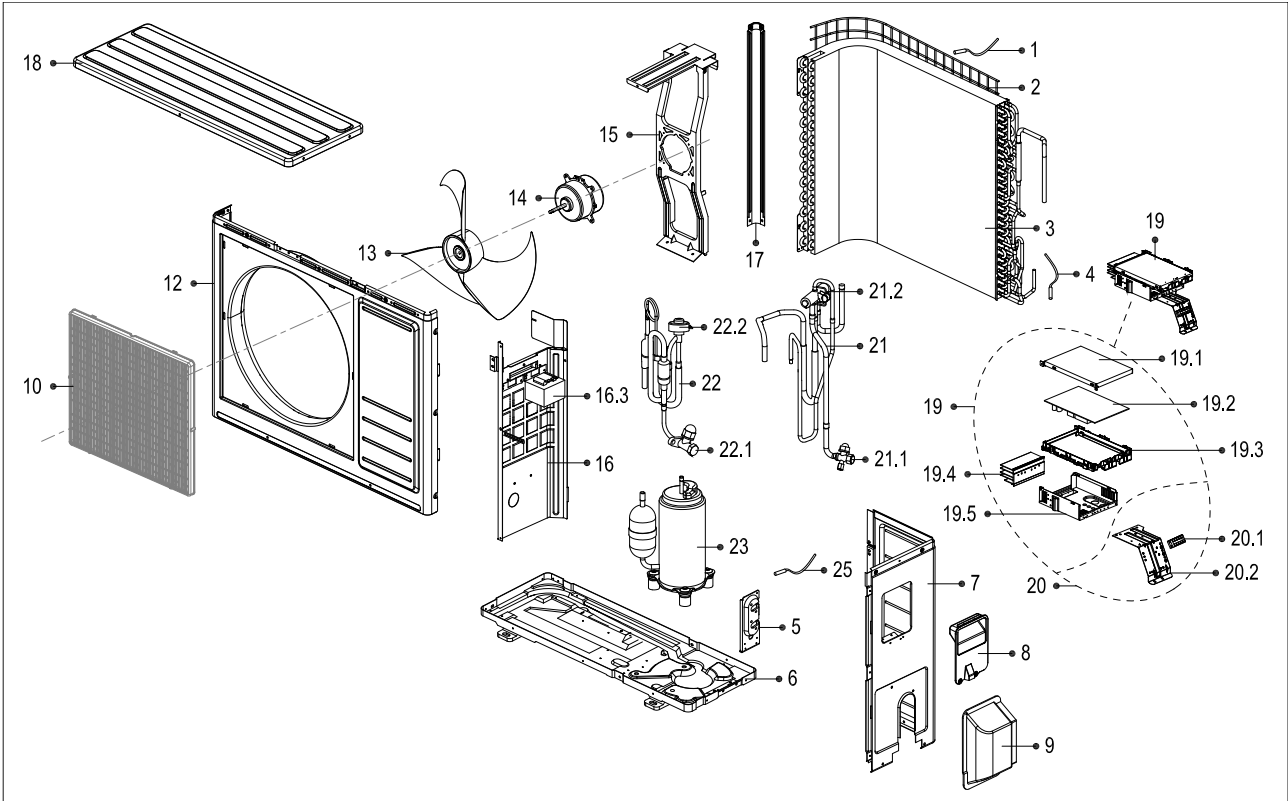

No.	BOM Code	Part Name	Quantity
1	202301300115	Ambient temperature sensor assembly	1
2	2011374G0003	Rear net	1
3	201537390033	Condenser assembly	1
4	202440500004	Pipe temperature sensor assembly	1
5	201237200299	Valve plate	1
6	201237590104	Chassis assembly	1
7	201237500263	Right clapboard assembly	1
8	201148100123	Big handle	1
9	201137400000	Water collector	1
10	2011374A0004	Air outlet grille	1
	2011374A0005	Round sticker of air outlet grille	1
12	201237400392	Front panel	1
13	201100390002	Axial flow fan	1
14	202400300536	Brushless DC Motor	1
15	201237390026	Supporter assembly of fan motor	1
16	201237500241	Partition board assembly	1
16.3	202301000867	Reactor	1
17	201237400400	Left supporter	1
18	201237900028	Top cover assembly	1
19	203337590128	Electronic control box assembly	1
19.1	201237300162	Cover of electronic control box	1
19.2	201337590104	Outdoor main control board assembly	1
19.3	201137300162	Support of electronic control box	1
19.4	202301990015	Radiator	1
19.5	201237300033	Electronic installing box	1
20	203337590135	Terminal board assembly	1
20.1	202301400015	Wire joint	1
20.2	201237590046	Terminal board	1
21	201637391703	4-Ways valve assembly	1
21.1	201600720095	Gas valve	1
21.2	201600600521	4-Ways valve	1
22	201637391551	Liquid valve assembly	1
22.1	201600740523	Liquid valve	1
22.2	201601300554	Electronic expansion valve assembly	1
23	201400611186	Compressor	1
25	202301310068	Discharge temperature sensor assembly	1

EXPLODED VIEW

AWAU-YND018-H11:

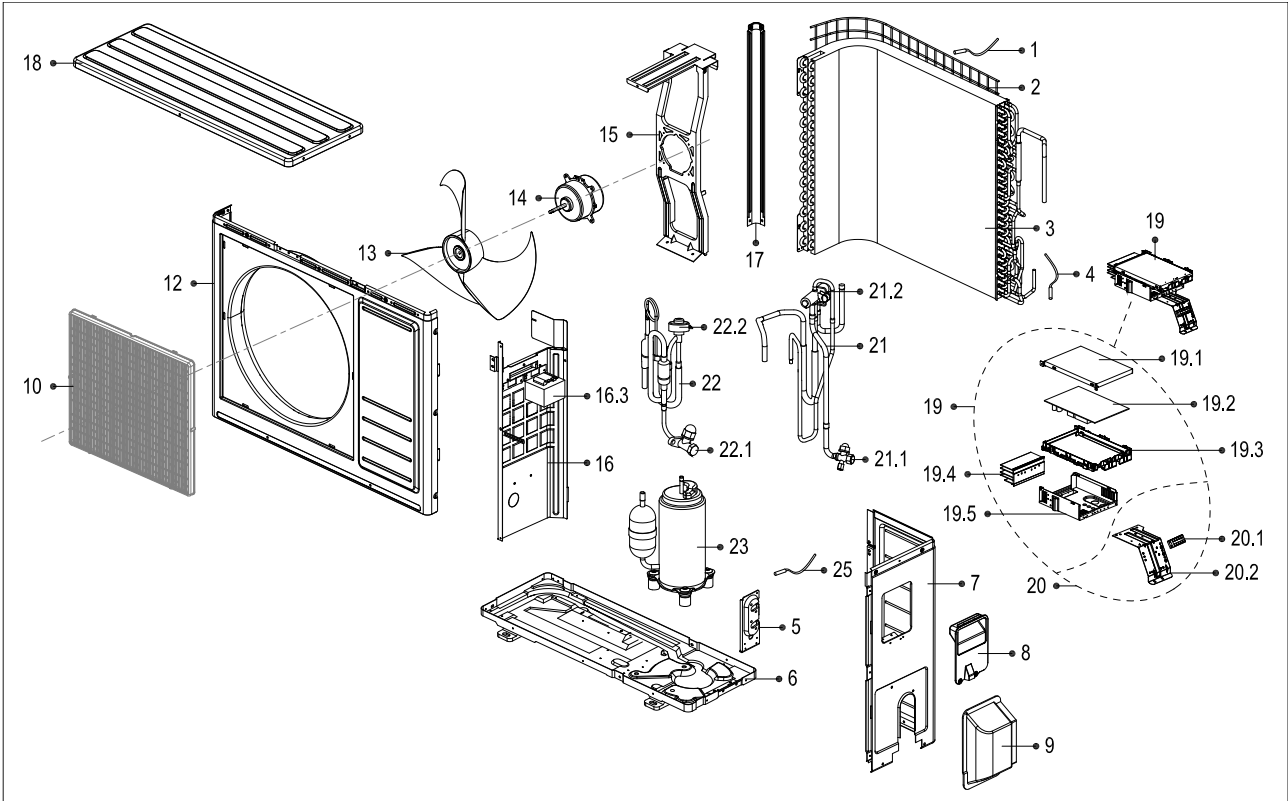

No.	BOM Code	Part Name	Quantity
1	202301300115	Ambient temperature sensor assembly	1
2	2011374G0003	Rear net	1
3	201537390033	Condenser assembly	1
4	202440500004	Pipe temperature sensor assembly	1
5	201237200299	Valve plate	1
6	201237590104	Chassis assembly	1
7	201237500263	Right clapboard assembly	1
8	201148100123	Big handle	1
9	201137400000	Water collector	1
10	2011374A0004	Air outlet grille	1
	2011374A0005	Round sticker of air outlet grille	1
12	201237400392	Front panel	1
13	201100390002	Axial flow fan	1
14	202400300060	Brushless DC Motor	1
15	201237390026	Supporter assembly of fan motor	1
16	201237500242	Partition board assembly	1
16.3	202301000903	Reactor	1
17	201237400400	Left supporter	1
18	201237900028	Top cover assembly	1
19	203337790159	Electronic control box assembly	1
19.1	201237300162	Cover of electronic control box	1
19.2	201337790091	Outdoor main control board assembly	1
19.3	201137300162	Support of electronic control box	1
19.4	202301901222	Radiator	1
19.5	201237300033	Electronic installing box	1
20	203337590135	Terminal board assembly	1
20.1	202301400015	Wire joint	1
20.2	201237590046	Terminal board	1
21	201637891315	4-Ways valve assembly	1
21.1	201600720195	Gas valve	1
21.2	201600690011	4-Ways valve	1
22	201637591358	Liquid valve assembly	1
22.1	201600740523	Liquid valve	1
22.2	201601300554	Electronic expansion valve assembly	1
23	201400600530	Compressor	1
25	202301310068	Discharge temperature sensor assembly	1

EXPLODED VIEW

AWAU-YND024-H11:

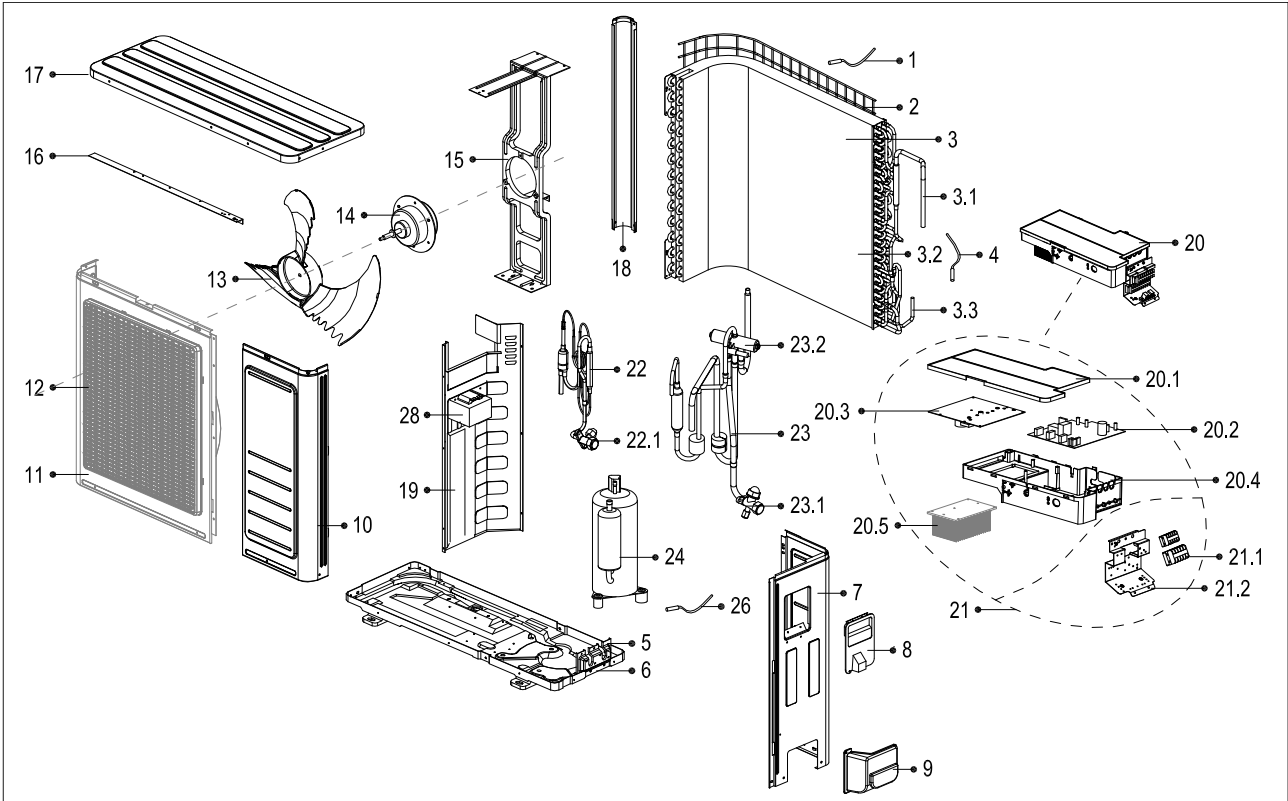

No.	BOM Code	Part Name	Quantity
1	202301310075	Ambient temperature sensor assembly	1
2	2011481G0001	Rear net	1
3	201537990084	Condenser assembly	1
3.1	201637991011	Input pipe assembly	1
3.2	201537990003	Condenser	1
3.3	201637991010	Output pipe	1
4	202301300111	Pipe temperature sensor assembly	1
5	201237300316	Valve plate	1
6	201237790056	Chassis assembly	1
7	201237990048	Rear right clapboard assembly	1
8	201157390007	Big handle	1
9	201137390017	Water collector	1
10	201248100389	Front right clapboard assembly	1
11	201248100390	Front panel	1
12	2011379A0005	Air outlet grille	1
	2011374A0005	Round sticker of air outlet grille	1
13	201100300553	Axial flow fan	1
14	202400300535	Brushless DC Motor	1
15	201257090067	Supporter assembly of fan motor	1
16	201248100384	Rear supporter	1
17	201248100266	Top cover assembly	1
18	201248100367	Left supporter	1
19	201257190118	Partition board assembly	1
20	203337990359	Electronic control box assembly	1
20.1	201157190011	Cover of electronic control box	1
20.2	201337990074	Outdoor main control board assembly	1
20.3	201357190124	Inverter control board assembly	1
20.4	201157190010	Electronic installing plate	1
20.5	202301901173	Radiator	1
21	203337990358	Terminal board assembly	1
21.1	202301450155	Wire joint	1
21.2	201257190117	Terminal board	1
22	201638091081	Liquid valve assembly	1
22.1	201600740704	Liquid valve	1
23	201638091083	4-ways valve assembly	1
23.1	201600720296	Gas valve	1
23.2	201600690011	4-ways valve	1
24	201400601740	Compressor	1
26	202448200000	Discharge temperature sensor assembly	1
28	202301000943	Reactor	1



SERVICE MANUAL
HNDDCISeries