

Airwell

■ *Just feel well*

Installation and maintenance manual

PAC HT

High temperature
air-water heat pump

PAC HT
12-6 / 14-7 / 18-9



Airwell
Residential



**POWER SUPPLY MUST BE SWITCHED OFF
BEFORE STARTING WORK IN THE ELECTRIC CONTROL BOX**

[GENERAL RECOMMENDATIONS]

Please read the following safety precautions very carefully before installing the unit.

■ SAFETY DIRECTIONS

Follow the safety rules in forces when you are working on your appliance.

The installation, commissioning and maintenance of these units should be performed by qualified personnel having a good knowledge of standards and local regulations, as well as experience of this type of equipment.

This appliance has not been designed for use by persons (including children) with reduced physical, sensorial or mental faculties or by persons without any experience or knowledge of heating systems, unless they act under the safety and supervision of a responsible person or have received prior training concerning the use of the appliance.

Children should be supervised to ensure that they do not play with the appliance.

The unit should be handled using lifting and handling equipment appropriate to the unit's size and weight.

Any wiring produced on site must comply with the corresponding national electrical regulations.

Make sure that the power supply and its frequency are adapted to the required electric current of operation, taking into account specific conditions of the location and the current required for any other appliance connected to the same circuit.

The unit must be EARTHED to avoid any risks caused by insulation defects.

It is forbidden to start any work on the electrical components if water or high humidity is present on the installation site.

■ WARNING

Cutoff power supply before starting to work on the appliance.

When making the hydraulic connections, ensure that no impurities are introduced into the pipe work.

The manufacturer declines any responsibility and the warranty becomes void if these instructions are not respected.

If you meet a problem, please call the Technical Department of your area.

If possible, assemble the compulsory or optional accessories before placing the appliance on its final location. (see instructions provided with each accessory).

In order to become fully familiar with the appliance, we suggest to read also our Technical Instructions.

The information contained in these Instructions are subject to modification without advance notice.

EQUIPEMENT SAFETY DATA

Safety Data	R407C
Toxicity	Low
In contact with skin	Liquid splashes or sprays may cause freeze burns. Unlikely to be hazardous by skin absorption. However, R407C may be slightly irritant and, if liquid, it has a strong degreasing effect. Flush contaminated skin areas with running water. If it comes into contact with fabrics, the liquid refrigerant will cause them to freeze and adhere to the skin. Carefully remove the contaminated clothing since it might adhere to the skin and cause freeze burns. Contact a doctor if the affected skin areas are reddened or irritated.
In contact with eyes	Vapours have no effect. Liquid splashes or sprays may cause freeze burns. In these cases rinse your eyes with running water or with a solution for eye lavages for at least 10 minutes. Immediately contact a doctor.
Ingestion	Very unlikely to occur. If this should be the case, it may cause freeze burns. Never induce vomiting. Keep the patient awake. Make him rinse his mouth with running water and make him drink about 1/4 of a litre. Immediately contact a doctor.
Inhalation	R407C: High concentration levels of its vapours in the air can produce an anaesthetic effect, including the loss of consciousness. Particularly severe exposures may cause heart arrhythmia and sometimes prove to be also fatal. At high concentrations there is a danger of asphyxia due to a reduced oxygen content in the atmosphere. In these cases take the patient to the open air, in a cool place and keep him at rest. Administer oxygen, if required. Apply artificial respiration if breathing has ceased or if it has become irregular. In case of heart failure immediately apply cardiac massage. Immediately contact a doctor.
Further Medical Advice	A symptomatic and supportive therapy is generally suitable. A heart sensitisation has been observed in some cases, as a result of exposures to particularly high concentrations. In the presence of catecholamines (such as for example adrenaline) in the blood flow, it has increased the irregularity of the cardiac rhythm and then caused the heart failure.
Long-term exposure	R407C: A lifetime study which has been conducted on the effects inhalation may have on rats at 50,000 ppm has shown the onset of benign tumours of the testicle. These remarks suggest that there is no danger for human beings if they are exposed to concentrations below the occupational limits or equal to them.
Occupational exposure limits	R407C: Recommended limits: 1,000 ppm v/v 8 hours TWA.
Stability	R407C: Not specified.
Conditions to avoid	Use in the presence of exposed flames, red heat surfaces and high humidity levels.
Hazardous reactions	Possibility of violent reactions with sodium, potassium, barium and other alkaline substances. Incompatible materials: magnesium and all the alloys containing over 2% of magnesium.
Hazardous decomposition products	R407 C: Halogen acids deriving from thermal decomposition and hydrolysis.
General precautions	Avoid the inhalation of high concentrations of vapours. The concentration in the atmosphere shall be kept at the minimum value and anyway below the occupational limits. Since vapours are heavier than air and they tend to stagnate and to build up in closed areas, any opening for ventilation shall be made at the lowest level.
Breathing protection	In case of doubt about the actual concentration, wear breathing apparatus. It should be self-contained and approved by the bodies for safety protection.
Storage Preservation	Refrigerant containers shall be stored in a cool place, away from fire risk, direct sunlight and all heat sources, such as radiators. The maximum temperature shall never exceed 45°C in the storage place.
Protection clothes	Wear boots, safety gloves and glasses or masks for facial protection.
Behaviour in case of leaks or escapes	Never forget to wear protection clothes and breathing apparatus. Isolate the source of the leakage, provided that this operation may be performed in safety conditions. Any small quantity of refrigerant which may have escaped in its liquid state may evaporate provided that the room is well ventilated. In case of a large leakage, ventilate the room immediately. Stop the leakage with sand, earth or any suitable absorbing material. Prevent the liquid refrigerant from flowing into drains, sewers, foundations or absorbing wells since its vapours may create an asphyxiating atmosphere.
Disposal	The best procedure involves recovery and recycle. If this is not possible, the refrigerant shall be given to a plant which is well equipped to destroy and neutralise any acid and toxic by-product which may derive from its disposal.
Combustibility features	R407C: Non flammable in the atmosphere.
Containers	If they are exposed to the fire, they shall be constantly cooled down by water sprays. Containers may explode if they are overheated.
Behaviour in case of fire	In case of fire wear protection clothes and self-contained breathing apparatus.

[INSPECTION AND STORAGE]

At the time of receiving the equipment carefully cross check all the elements against the shipping documents in order to ensure that all the crates and boxes have been received. Inspect all the units for any visible or hidden damage.

In the event of shipping damage, write precise details of the damage on the shipper's delivery note and send immediately a registered letter to the shipper within 48 hours, clearly stating the damage caused. Forward a copy of this letter to the manufacturer or his representative.

Never store or transport the unit upside down. It must be stored indoors, completely protected from rain, snow etc. The unit must not be damaged by changes in the weather (high and low temperatures). Excessively high temperatures (above 60 °C) can harm certain plastic materials and cause permanent damage. Moreover, the performance of certain electrical or electronic components can be impaired.

[WARRANTY]

The units are delivered fully assembled and tested.

Any modification to the units without the manufacturer's prior approval, shall automatically render the warranty null and void.

The following conditions must be respected in order to maintain the validity of the warranty:

- Commissioning shall be performed by specialised technicians from technical services approved by the manufacturer.
- Maintenance shall be performed by technicians trained for this purpose.
- Only Original Equipment spare parts shall be used.
- All the operations listed in the present manual shall be performed within the required time limits.



THE WARRANTY SHALL BE NULL AND VOID IN THE EVENT OF NON-COMPLIANCE WITH ANY OF THE ABOVE CONDITIONS.

[CONTENTS OF PACKAGE]

- 1 PAC HT
- 1 Documentation pouch
- 1 Water filter kit
- 1 stop cock
- 4 Anti-vibration pads

[PRODUCT PRESENTATION]

This range of air/water **PAC HT** (High Temperature) appliances offers the special feature of producing hot water at 65° C at outdoor temperatures between 0° C and -20° C, while guaranteeing a high COP.

Between 0°C and +42°C, the temperature of the hot water produced varies between 65°C and 55°C for the Heating mode and is maintained at 60°C for the Domestic Hot Water (DHW) mode.

Consequently, this **PAC HT** system is ideally suited to replace a traditional hot water boiler in producing DHW without alterations to the rest of the system.

This technology uses two-stage compressors connected to a patented refrigeration circuit.

This technology ensures remarkably accurate "capacity supplied/heating needs" matching due to its ability to run each compressor independently. Depending on the demand for heating capacity and the operating temperature of heat emitters (i.e. radiators, etc.) the **PAC HT** regulator selects either the small or large compressor to operate on its own or in a two-stage mode.

[ACCESSORIES]

- Set of stop cocks with pressure tap
 - Set of 2 flexible pipes (length 1m)
 - Hydraulic connection kit
 - Sludge pot (decanting filter)
 - Domestic hot water tank (300l)
 - Domestic hot water plate exchanger kits for:
 - wall-mounted electric tank (DHW outflow via the bottom)
 - floor-mounted electric tank (DHW outflow via the top)
 - Directional valve to be linked to the:
 - domestic Hot Water function.
 - boiler substitution function
 - swimming pool function (with temperature probe kit)
 - 140 litre buffer tank
 - Anti-vibration pads (Anti-vibration mountings)
 - 6kW in-line electric heater
 - Dual zone Under-floor / Radiator heating kit (modulating valve + electric control box + temperature probe)
 - Dual zone management kit for existing valve (electric control box + temperature probe)
 - Wired programmable ambience terminal
 - Wireless programmable ambience terminal
- } **Accessory recommended for an optimal functioning**

[DIMENSIONS]

→ See Appendix

[HANDLING]

Take care to avoid any rough handling or impacts when unloading and moving the appliance. Only push or pull the appliance by its base. Place a safety wedge between the unit base and the fork lift truck to avoid damaging the unit's structure and casing.

The handles present on the appliance's panels are intended for the removal/refitting of the latter and must not be used for handling the complete appliance (too heavy to be supported by the panels).

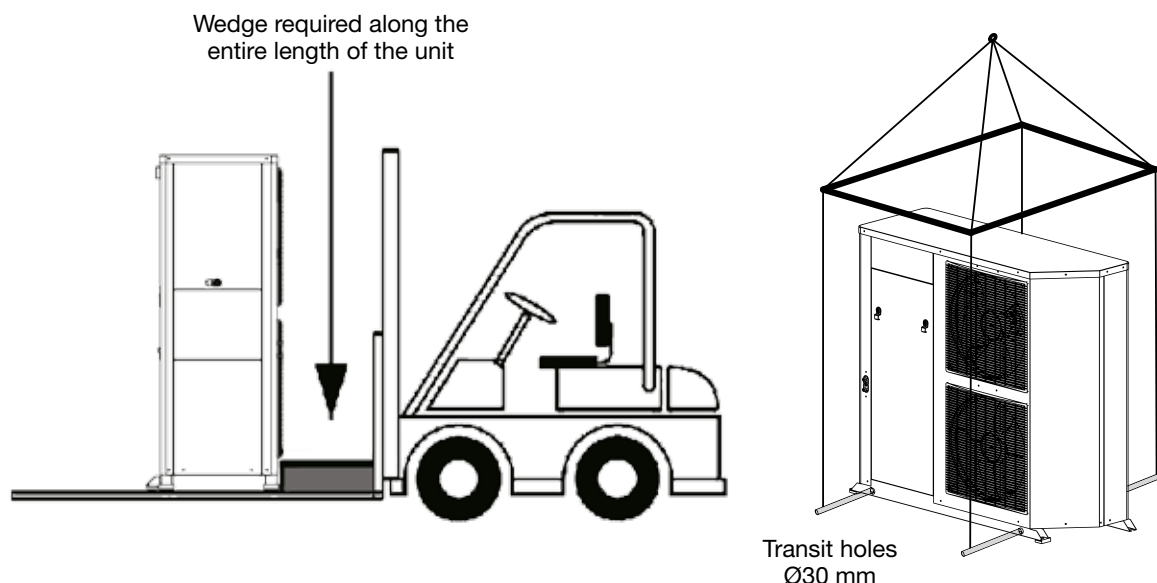

[NET WEIGHT (kg)]

12-6	14-7	18-9
184	209	213

[TECHNICAL SPECIFICATIONS]

■ PHYSICAL CHARACTERISTICS

		12-6	14-7	18-9
REFRIGERANT				
Type		R407C		
Factory charge	g	SEE NAME PLATE		
HYDRAULIC LINKS				
Inlet water	gas	1" Female / Rotating nut		
Outlet water	gas	1" Female / Rotating nut		
WATER FLOW				
Nominal	l/h	1030 / 1230		1480
Minimum	l/h	880 / 1050		1260
Maximum	l/h	1170 / 1390		1670
FANS				
Fans (x2)		206 W - 700 tr/mn - 6000 m ³ /h		
ACOUSTIC PRESSURE				
Acoustic pressure – outdoor unit	dB(A)	65	65	65

This equipment contains fluorinated gas with greenhouse gas effects covered by the Kyoto agreement.

■ ELECTRICAL CHARACTERISTICS

		12-6	14-7	18-9
Supply voltage		400V / 3 Ph / 50Hz		
Start-up current draw with limiter	A	< 60		
MAXIMUM CURRENT				
Only PAC HT	A	12.2	13.2	15.2
PAC HT + accessories	A	15.5	16.5	18.5
Supply voltage		230V / 1 Ph / 50Hz		
Start-up current draw with limiter	A	< 45		
MAXIMUM CURRENT				
Only PAC HT	A	25.7	27.2	/
PAC HT + accessories	A	29	30.5	/

■ OPTIONS COMPATIBILITY

The card μ PC allows to install one or two options at most. The various possible configurations are the following ones:

- Domestic hot water plate exchanger kits (SE4287)
- Dual zone kit (SE4288)
- Boilier relief (SE4289 or SE4290)
- Electric heater kit (SE4291 or SE4292)
- Domestic hot water tank (SE4290 or SE4291 or SE4293)
- Dual zone kit + boilier relief (SE4289)
- Dual zone kit + electric heater kit (SE4292)
- Dual zone kit + Domestic hot water tank (SE4293)
- Domestic hot water tank + boilier relief (SE4290)
- Domestic hot water tank + electric heater kit (SE4291)



■ OPERATING LIMITS

PAC HT appliances are equipped with a 2-stage output system with a ratio of 1:2.

When heating needs are low and when the required outlet water temperature is below 55° C, only the first stage is used at reduced capacity until the temperature balance point is reached. In other cases, the **PAC HT** operates at full capacity to supply heating needs until the chosen balance point is reached.

The outlet water temperature is automatically adjusted to the water rule (heating curve) up to a maximum temperature of 65° C.

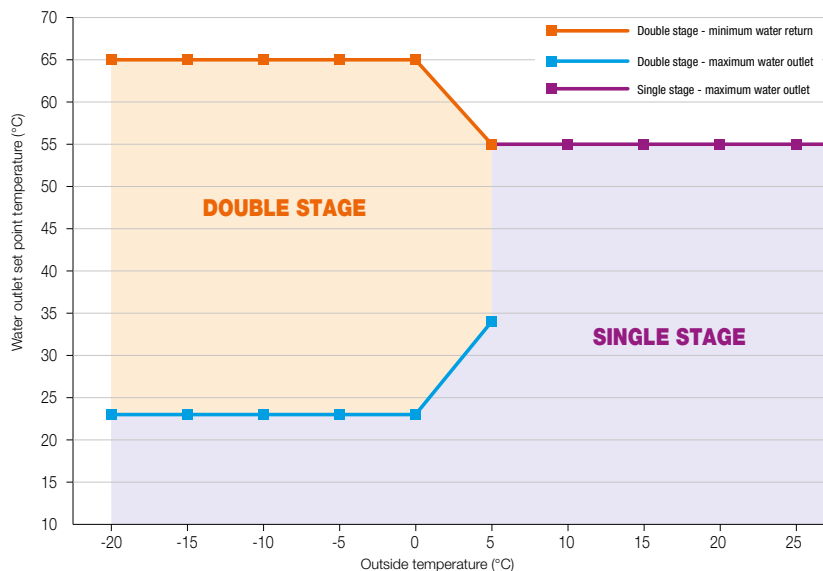

■ THERMODYNAMIC DOMESTIC HOT WATER PRODUCTION

→ Performances

		PAC HT 12-6				PAC HT 14-7				PAC HT 18-9			
		Compressor C2		Compressor C1+C2		Compressor C2		Compressor C1+C2		Compressor C2		Compressor C1+C2	
Configuration													
Outdoor temp.	°C	40	7	0	-10	40	7	0	-10	40	7	0	-10
PAC max. outlet temp.	°C	60	60	65	65	60	60	65	65	60	60	65	65
Average capacity	kW	9	5.5	10.6	9.3	11	7.1	13.6	12	13.3	8.3	16	14.1
DHW temperature	°C	56	58	58	58	54	57	56	57	53	56	55	56
Time [min] Initial temperature: 15°C	min	97	163	85	98	72	124	63	73	60	103	52	61
Time [min] Initial temperature: 35°C	min	49	87	45	53	35	65	32	38	28	53	26	31

Tank capacity: 300 litres

THE ABOVE PERFORMANCE FIGURES ARE STATED FOR A SYSTEM WITH THE DOMESTIC HOT WATER TANK ACCESSORY.

The tank is equipped with a 2.5kW back-up heating element for single or three phase connection. The performances obtained and stated in the above table are without back-up heating. For higher domestic hot water temperatures or for Legionnaires disease protection treatment, the use of the back-up electric heating resistances is required.

→ Pressure loss

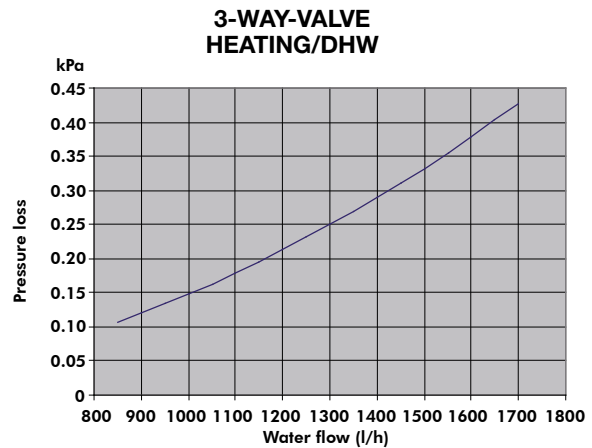
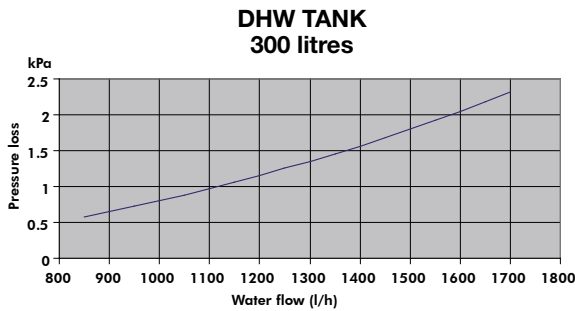

[REFRIGERATION AND HYDRAULIC DIAGRAM]

→ See Appendix

[INSTALLATION]



The unit is not designed to withstand weights or stresses from adjacent equipment, pipe work or constructions. Any foreign weight or stress on the unit structure could lead to a malfunction or a collapse with dangerous consequences for personnel and property. In such an event, the warranty shall be null and void.

■ SITING THE INSTALLATION

The outdoor unit must be installed outdoors with sufficient surrounding clearance to enable unobstructed air circulation through the appliance and access for maintenance work.

→ **Prevailing wind**

In the case of the unit being sited in areas exposed to high winds, you must avoid the wind hitting the fan blowing surface areas directly to avoid any risk of recycling cooled air. Exchanger fan operation can be disrupted by strong winds, which can cause de-icing problems and fan malfunctions.

Unit operation depends on air temperature. Any recycling of air extracted by the fan lowers the air intake temperature across the exchanger fins and alters the standard operating conditions.

The arrows show the direction of air circulation through the appliance. (Refer to the § ATTACHEMENT TO THE GROUND).

→ **Condensate water management**

Depending on temperature and outdoor air humidity conditions, water vapour contained in the air can condense on the finned heat exchanger and even form ice under low outdoor temperature conditions (around $< 5^{\circ}\text{C}$). This condensate water and defrosted water runs off via outlets provided under the exchanger. To aid water run-off and avoid frozen water remaining in the appliance in winter, we recommend that it is mounted at a height of around 10cm off the ground by installing the ant-vibration mounting kit. In this way, condensate and defrosted water can run off freely and be absorbed into the ground or channelled to a basin built under the appliance in order to protect the environment.

In areas where outdoor temperatures fall below 1°C , the system can be equipped with a condensate anti-freeze protection system (e.g. a heated pipe sheath, Not supplied).

→ **How to reduce noise pollution**

In order to contain noise levels, we equip our appliances with quiet fans and encase the technical compartment in sound-proofed panels. However, noise levels can be reduced even further by following a few installation precautions:

- Do not install the appliance near a bedroom window. Avoid locating the appliance in a corner (increased reverberated noise).
- Install the rubber pads supplied or anti-vibration pads (available as an option) under the appliance.
- Do not join the concrete slab supporting the appliance to the structure of the dwelling (structure-borne noise transmission).

■ CLEARANCE

When choosing the location for the appliance, take care to leave sufficient free clearance on all sides to ensure easy access for maintenance work. The minimum free clearance dimensions indicated must be observed to ensure both proper system operation and allow access for maintenance and cleaning.

REF.	DIMENSION
A	800 mm
B	500 mm
C	500 mm
D	400 mm
E	800 mm
F	100 mm

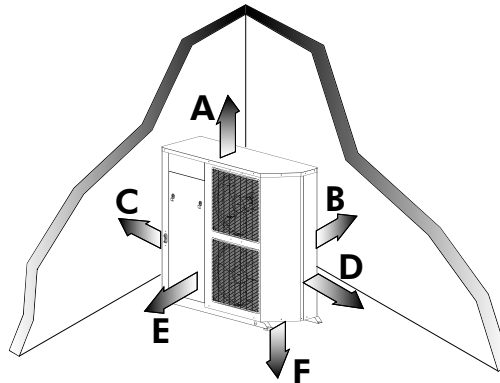

■ ATTACHEMENT TO THE GROUND

The appliance must be sited on a level and solid floor and preferably on a masonry surface.

Unit mounting measurements are shown on the drawing opposite. A slope of 1 cm/m should be created to assist rainwater drainage.

Vibration dampers must be fitted during installation to overcome any risks of vibration being transmitted due to direct contact with a rigid support surface.

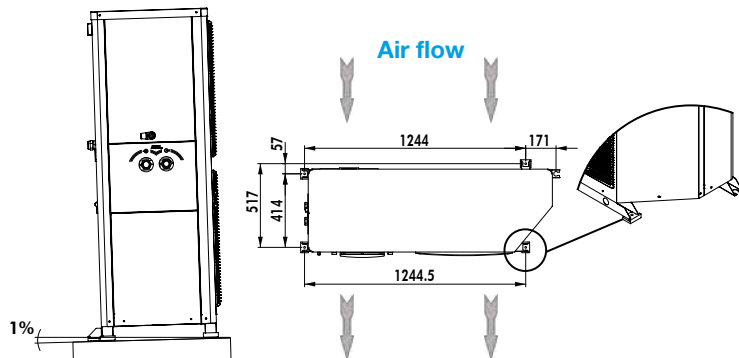

THE UNIT MUST NEVER BE INSTALLED ON A WALL BRACKET.

■ MOUNTING WITH ANTI-VIBRATION SUPPORTS

Angled feet

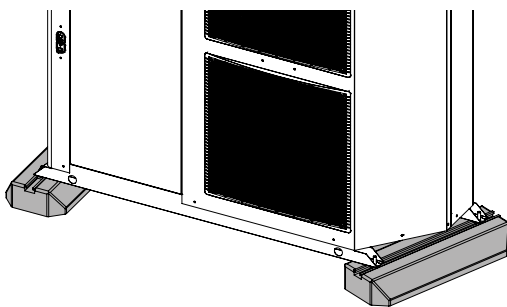

Parallel feet

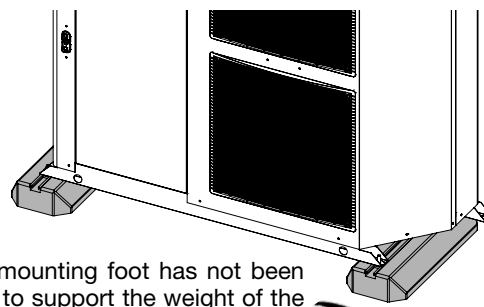

The rear mounting foot has not been designed to support the weight of the unit on its own.

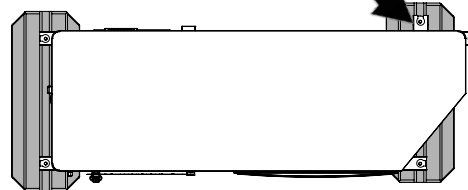
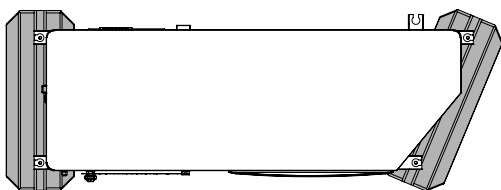

THE REAR FOOT MUST BE USED IN ACCORDANCE WITH THE ASSEMBLY ILLUSTRATED BELOW.

[HYDRAULIC LINKS]

When choosing and installing water pipes, you must consult and observe all current local standards, regulations and instructions.

■ GENERAL RECOMMENDATIONS

You must design the pipe network with the minimum number of bends and keep the number of changes in height to the strict minimum. This will reduce installation costs and ensure optimum system performance. The pipe network must include:

- A vibration elimination system (e.g.: link hoses available as an accessory) on all pipes connected to the appliance in order to reduce vibrations and noise transmitted to the building fabric.
- Stop cocks to isolate the hydraulic circuit during maintenance.
- Manual or automatic bleed valves at the highest point on the water circuit.
- A suitable system for maintaining water pressure in the circuit (expansion tank).
- The installation of thermometers and pressure gauges on the heat exchanger inlet and outlet to facilitate day-to-day controls and system maintenance.

■ ANTI-CLOGGING PROTECTION

To avoid any risk of foreign bodies entering the appliance and to guarantee operating performance, **WE STRONGLY RECOMMEND THAT YOU INSTALL THE WATER FILTER ACCESSORY on the PAC HT inlet pipe.**

When installing **PAC HT** appliances in existing water circuits, a sludge trap and a removable mesh filter should be installed upstream of the appliance.

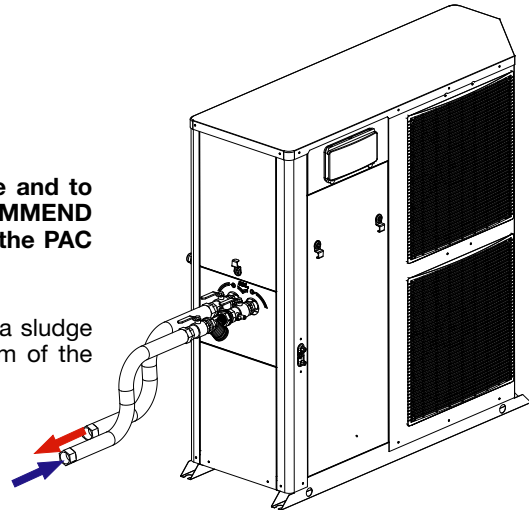

■ MINIMUM HEATED WATER VOLUME REQUIREMENTS – BUFFER TANK.

To ensure that the system operates correctly you must use suitably sized and properly routed pipes for the hydraulic links between the Heat pump and the mains network.

The volume of water contained in the installation must be sufficient to avoid any possibility of the compressor “short cycling”, and to guarantee adequate compressor running times in order to provide optimum service life and to ensure that de-icing cycles are performed properly. To ensure the **PAC HT** functions efficiently, available installation water volume must be:



200L < AVAILABLE WATER VOLUME < 250L

When water circulation through heat emitters can be interrupted (thermostatic radiator valves closed) or the heating supply halted, you must ensure that:

- The heat pump maintains its nominal water flow,
- The heat pump operates in a loop with a minimum available volume of 200 litres.

The use of a 3-speed circulation pump enables water flow through the appliance to be adapted to pressure losses in the system. (Pump supplied set on Max position).

STANDARD CIRCUITS

→ PAC HT only

Layout 1: Application without room by room regulation

This layout is recommended when the **PAC HT** water flow is continuous and close to the nominal value (no thermostatic valves).

The buffer tank (2) provides extra circulating water volume to maintain the minimum volume.

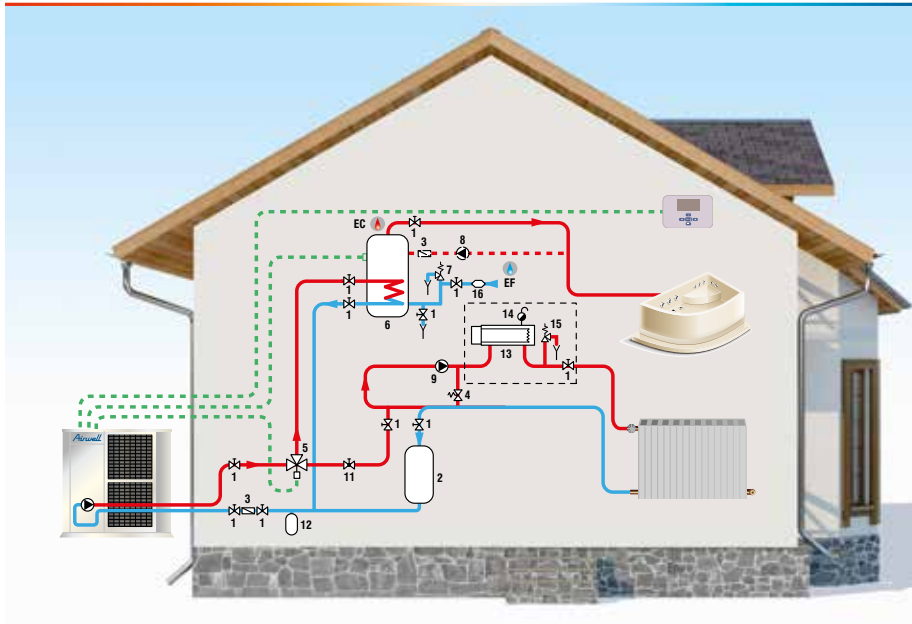

Layout 2: Application with room by room regulation

This layout is recommended for heating installations with wide operating water flow variations (radiator thermostatic valves present in the system). We strongly recommend including the buffer tank (2) as it guarantees that the heating loop capacity is higher than the minimum volume when the maximum number of thermostatic valves are closed.

The flow regulating valve (11) is used to balance the flow in heating mode and domestic hot water production mode to always ensure optimum **PAC HT** operation.

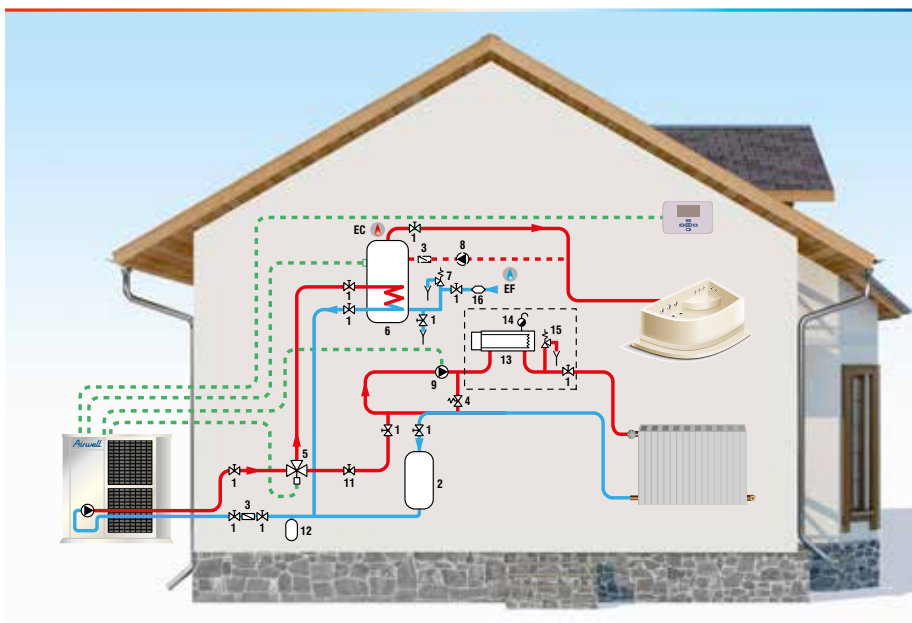

CAPTIONS

NO.	NAME
1	Shut-off valve
2	Buffer tank
3	Water filter Pot
4	Sludge pot
5	Three-way domestic hot water valve
6	300-litre domestic hot water tank
7	Plumbing safety unit
8	Recirculator pump
9	Circulator pump
11	Flow adjustment valve
12	Expansion vessel
13	On-line heater (optional)
14	Bleeder
15	Safety valve
16	Backflow preventer
	Cold water
	Hot water
	Heat pump communication
	DHW recycling loop

* Components not supplied.

** Always check that the capacity of the vessel is suitable for the installation.

Mandatory accessory.









Layout 3: Application with room by room regulation

This layout is also recommended for heating installations with wide operating water flow variations (radiator thermostatic valves present in the system). Minimum system volume is guaranteed by a mixing tank (10). Take care when calculating the volume of water in the installation and only take account of 50% of the mixing tank's volume.

Example: For a useful volume of 100 litres the actual mixing tank volume will be 200 litres.

The flow regulating valve (11) is used to balance the flow in heating mode and domestic hot water production mode to always ensure optimum **PAC HT** operation.

CAPTIONS

REP.	DÉSIGNATION
1	Shut-off valve
3	Water filter  Pot 
4	Pressure release valve
5	Domestic Hot Water 3-way valve
6	300-litre domestic hot water tank
7	Plumbing safety unit
8	Recirculator pump
9	Circulator pump
10	140-litre mixing tank
11	Flow adjustment valve
12	Expansion vessel 
13	Optional in line warmer (see top diagram)
14	Drain or boiler
15	Safety valve 
16	Backflow preventer 
17	Domestic hot water preparation kit
	Cold water
	Hot water
	Heat pump communication
	DHW recycling loop

* Components not supplied.

** Always check that the capacity of the vessel is suitable for the installation.

 Mandatory accessory.

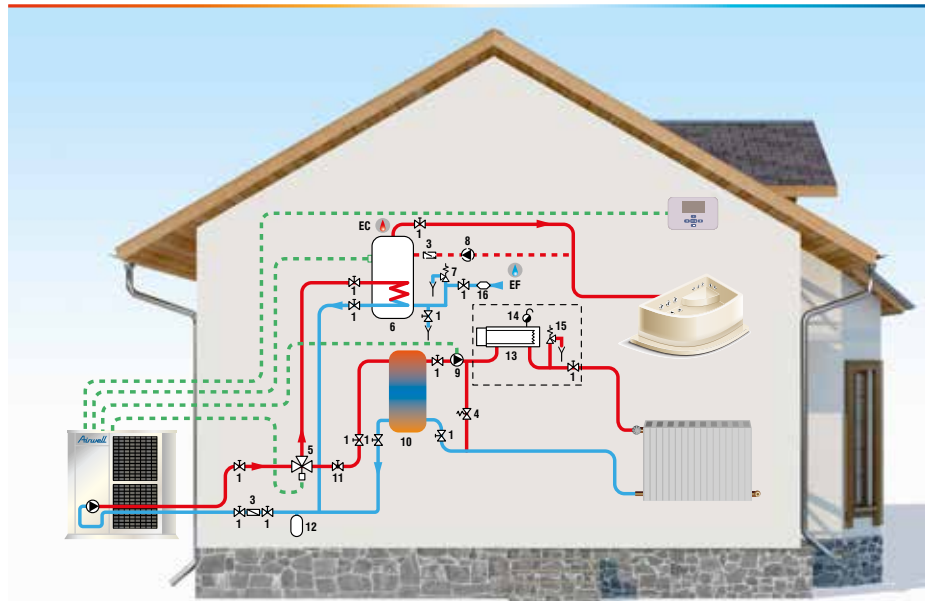

Layout 4: Domestic Hot Water (DHW) production by way of the plate exchanger kit for fitment on the existing DHW tank

Example: for a wall-mounted tank (DHW outflow via the bottom)

A different kit is required for a floor-mounted tank (DHW outflow via the top). Please refer to the corresponding documentation.

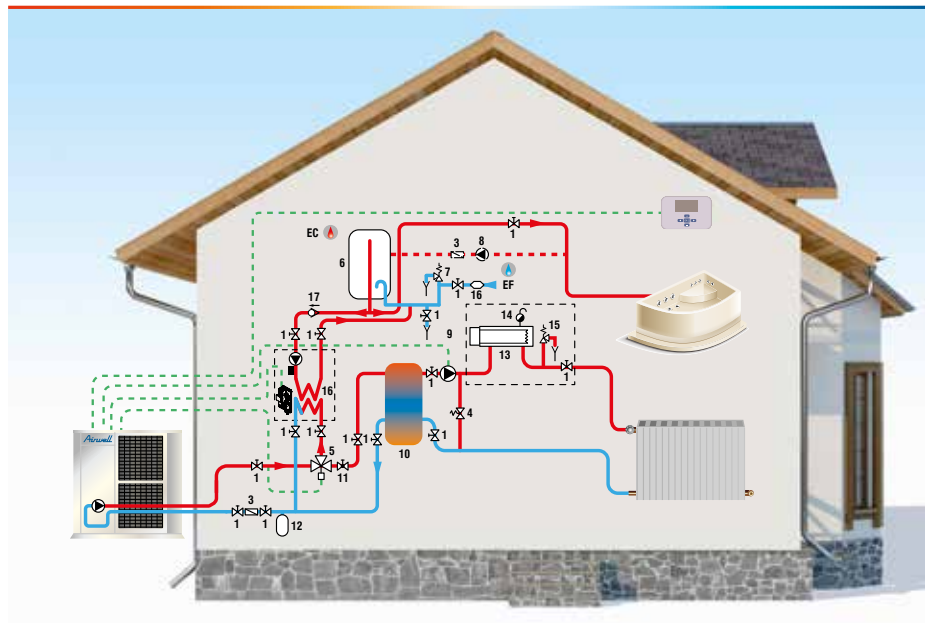

→ **PAC HT as a boiler substitute**

We recommend the fitting of a zone valve to avoid heat losses via the boiler when the **PAC HT** is working on its own. All system devices should be of a suitable size to limit pressure losses. Water flow within the heating circuit is normally driven by the circulation pump already present in the installation (recommended solution) or by the **PAC HT**'s circulation pump. In this case, you must ensure that the circulation pump generates sufficient water pressure.

There is no need to replace the existing buffer tank on the circuit to take account of the small volume of water added by the presence of the **PAC HT**.

IMPORTANT: the hydraulic kit available as an option enables you to prepare the circuit for connection to the **PAC HT** in accordance with our recommendations. The hydraulic kit is available with or without zone valves.

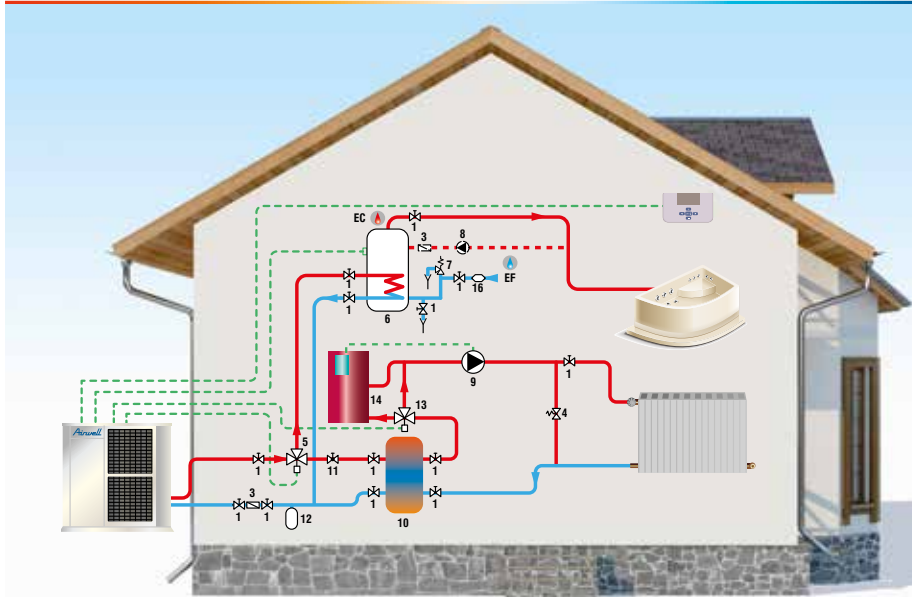

DO NOT FIT A BOILER SUBSTITUTE VALVE:

- WALL-MOUNTED GAS-FIRED BOILER with domestic hot water production and a single circulation pump used for both heating and domestic hot water.
- BOILER with a circulation pump.

→ **PAC HT dual zone installation (under-floor heating + radiators)**

The **PAC HT** manages a radiator zone (high temperature, zone 2) and an under-floor heating zone (low temperature, zone 1) by way of an under-floor temperature outlet probe, a modulating 3-way valve (230V 3 phase motor) and a water circulation pump for each zone. Each zone can be controlled by a dedicated ambience terminal, which then enables the **PAC HT** to manage 2 independent water laws. When the radiators zone is not in operation, the **PAC HT** switches over automatically to the under-floor heating water law, and thereby optimises the seasonal COP for the entire installation.

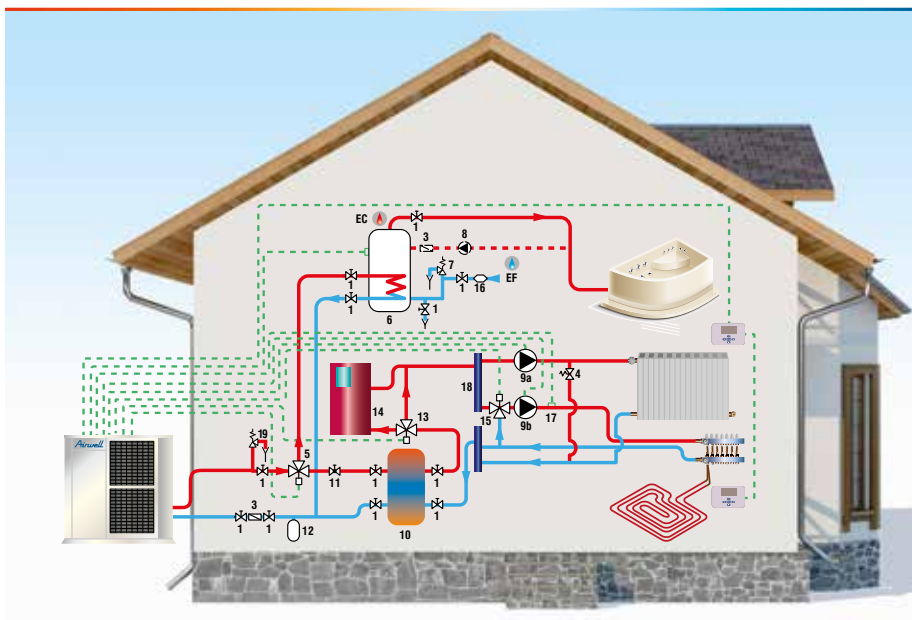

CAPTIONS

NO.	NAME
1	Shut-off valve
3	Water filter
4	Pressure release valve
5	Three-way domestic hot water valve
6	300-litre domestic hot water tank
7	Plumbing safety unit
8	Recirculator pump
9a/9b	Circulator pump
10	140-litre mixing tank
11	Flow adjustment valve
12	Expansion vessel
13	Three-way domestic hot water valve
14	Boiler
15	Mixer valve
16	Backflow preventer
17	Dual-zone kit probe
18	Feeder
19	Safety valve
20	Mixing tank
21	Controller
	Cold water
	Hot water
	Heat pump communication
	DHW recycling loop

* Components not supplied.

** Always check that the capacity of the vessel is suitable for the installation.

Mandatory accessory.

■ WATER QUALITY

The water must be analyzed; the hydraulic network system installed must include all elements necessary for water treatment: filters, additives, intermediate exchangers, drain valves, vents, check valves, etc., according to the results of the analysis.



The PAC HT must not run on a network with open loops, likely to cause incidents related to oxygenation, or with non treated table water.

Using improperly treated or non treated water in the **PAC HT** may cause scaling, erosion, corrosion or algae or sludge deposits in the exchangers. Refer to a specialist skilled in water treatment to determine any treatment to apply. The manufacturer will not be held liable for damages caused when non treated or improperly treated water, demineralized water, salty water or sea water are used.

Apply the following guidelines:

- No NH_4^+ ammonium ions in the water, highly detrimental to copper. $<10\text{mg/l}$
- Cl^- chloride ions are detrimental to copper with a risk of puncture by picking corrosion. $<10\text{mg/l}$.
- SO_4^{2-} sulphate ions may cause perforating corrosion. $<30\text{mg/l}$.
- No fluoride ions ($<0.1\text{ mg/l}$)
- No Fe^{2+} and Fe^{3+} ions, particularly in case of dissolved oxygen. $\text{Fe} < 5\text{mg/l}$ with dissolved oxygen $< 5\text{mg/l}$. The presence of these ions with dissolved oxygen indicates corrosion of steel parts, likely to generate corrosion of copper parts under Fe deposits, particularly in the case of multitubular exchangers.
- Dissolved silica: silica is an acid element of water and may also cause corrosion. Content $< 1\text{mg/l}$.
- Water hardness: TH $> 2.8\text{K}$. Values between 10 and 25 may be recommended. This facilitates scaling deposits likely to limit copper corrosion. Excess TH values may lead to clogging the pipes.
- TAC < 100
- Dissolved oxygen: Prevent any sudden change in the water's oxygenation conditions. Also, avoid deoxygenating water by sparging inert gas as well as overoxygenating it by pure oxygen sparging. Disturbing oxygenation conditions destabilizes copper hydroxides and particle salting-out.
- Electrical Resistivity - Conductivity: The higher the resistivity, the slower the corrosion. Values above 3000 ohm/cm are preferred. A neutral environment favours maximum resistivity. For electrical conductivity, values around $200\text{-}600\text{ S/cm}$ can be recommended.
- pH: neutral pH at 20°C ($7 < \text{pH} < 8$)



If the water circuit is to be drained for a time exceeding one month, the circuit must be fully charged with nitrogen to prevent any risk of corrosion by differential venting.



The manufacturer is not liable for recommendations in terms of water treatment (call a specialized company).
However, this matter has a critical nature, and particular care must be given to ensure that the type of treatment applied is effective.

The liability of the manufacturer or its representative will not be sought when non treated water or non compliant quality water is used.

■ CONNECTION TO THE CENTRAL HEATING LOOP

You must check water tightness and the cleanliness of the installation before connecting the **PAC HT**.

For the **PAC HT**'s WATER INLET and OUTLET connections, you must install manual stop cocks with the same diameter as the main pipe work. This will enable maintenance work to be carried out on the **PAC HT** without having to bleed the entire system. **A link valve with pressure tap kit is available.**

The **PAC HT** must be protected by a water filter. When connecting this device to the **PAC HT**, take care to keep the water filter sieve pointing downwards. A sludge trap should be fitted in the event of high sludge build-ups.



An expansion tank adapted to the volume of water in the installation must be installed.

It is important to ensure that the mains water supply pressure is sufficient to fill the installation.



THE MANUFACTURER'S WARRANTY IS VOID IF THE FILTER SUPPLIED WITH THE PAC HT IS NOT INSTALLED TO PROTECT THE APPLIANCE

WARNING!

Take care not to damage the hydraulic pipe links by applying too much tightening pressure. Use a second wrench to compensate for the tightening torque.

You should always use a counter-wrench for tightening valves.

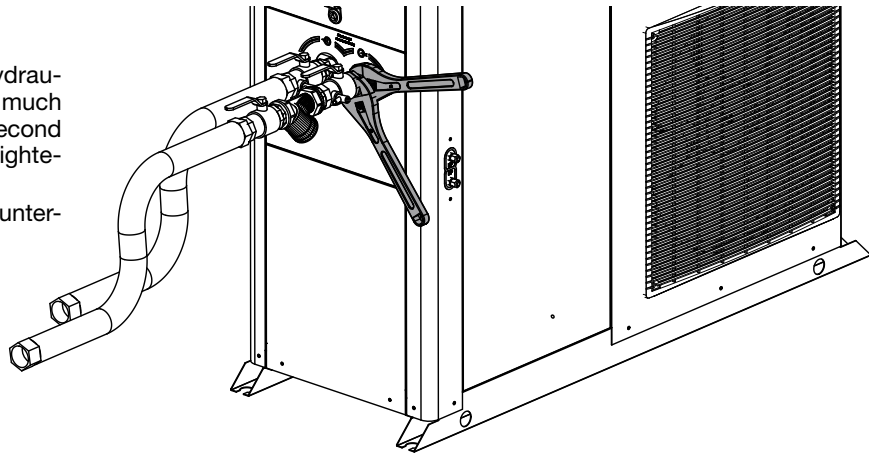

■ HEAT INSULATION

To guarantee proper energy efficiency and compliance with current standards, water pipes passing through uninhabited zones should be properly lagged to retain heat.

To achieve correct insulation with conductivity of 0.04 W/mK, lag the pipes with insulating material with a radial thickness between 25mm and 30 mm.

■ FILLING THE SYSTEM WITH WATER

Once the installation is complete and after having clean and rinsed out the circuit network, you must fill the water circuit in accordance with current professional standards until you obtain the service pressure which will be:

0.5 bar < P. service < 2.5 bars.

The **PAC HT** is equipped with an electronic water pressure sensor. This can be viewed on the main P1 screen on the display, as well as on the Maintenance screens.

The water supply should come either from the mains network or from the Heat Pump or from any other point on the installation.

Check that the automatic bleed valve operates correctly.

You must completely bleed the circuit of all air to ensure efficient operation.

Close the inlet water valve once the hydraulic circuit is filled correctly.

■ ELECTRONIC FLOW METER

The condenser water circuit is equipped with a vortex effect electronic flow meter. This device provides real-time readings of the installation's water flow and reassurance that this flow is adequate before starting the unit.

The appliance is also equipped with a group of safety devices including a valve set at 3 bars, and a manual relief valve.

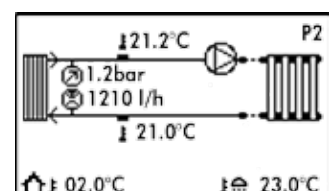
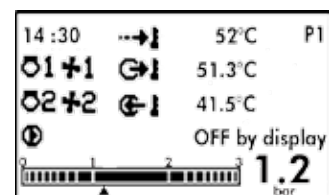

■ WATER FLOW REGULATION

Water flow can be viewed on screen P2 as well as on the Maintenance screens.

Use the water circulation pump speed selector to adjust the flow in the installation at the recommended nominal value (Refer to the § PHYSICAL CHARACTERISTICS). Pressure drop of the installation must be situated in the circulator operating range.

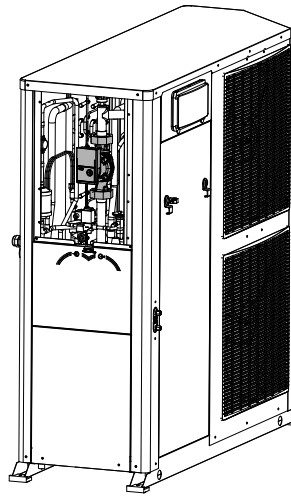

[WIRING DIAGRAM AND LEGEND]

■ WIRING DIAGRAM



→ See Appendix

■ LEGEND

N 802				
SE 4213	PAC HT 12-6	Power	1-Phase	230V +/-10% 50Hz
SE 4214	PAC HT 12-6	Control	1-Phase	230V +/-10% 50Hz
SE 4215	PAC HT 14-7	Power	1-Phase	230V +/-10% 50Hz
SE 4216	PAC HT 14-7	Control	1-Phase	230V +/-10% 50Hz
SE 4217	PAC HT 12-6/14-7	Power	3-Phases	3N~400V +/-10% 50Hz
SE 4218	PAC HT 12-6/14-7	Control	3-Phases	3N~400V +/-10% 50Hz
SE 4219	PAC HT 18-9	Power	3-Phases	3N~400V +/-10% 50Hz
SE 4220	PAC HT 18-9	Control	3-Phases	3N~400V +/-10% 50Hz

→ Power supply

Terminal connections:

230 V +/-10% 50 Hz	3N~400V +/-10% 50 Hz
L: phase	L1 (L1): phase
N: neutral	L2 (L2): phase
 : ground	L3 (L3): phase
	N (N): neutral
	 : ground

This supply comes from a CIRCUIT BREAKER or a FUSE HOLDER equipped with aM type fuses supplied by the installer. Fuse sizes are indicated on the chart on the following page.

The appliance's electrical installation and wiring must comply with the country's current standards.

→ **Wiring diagram key descriptions**

FT1/2	M1/2 compressors thermo-magnetic relay (three phase models)
FF1/2	M1/2 compressors protection fuse carrier (single phase models)
KM1/2	M1/2 compressors power contactor or relay
M1/2	Compressors
CM1/2	M1/2 compressors capacitors (single phase models)
AS1/2	“Soft START” starter
R1/2	Sump resistance
OF1/2	Air exchanger fan motor
KOF1	OF1 fan motor relay
FOF1/2	OF1/2 motors internal safety
COF1/2	OF1/2 motors capacitors
CF	OF1/2 fan motor variator
RAG	anti-freeze resistance
TAG	anti-freeze thermostat
FFC	Control circuit protection fuse carrier
KA1	Phase sequence and cut-out control module (three phase models)
μPC	Controller
FT1/2	Thermo-magnetic relays ancillary contacts for M1/2 compressors
HP	Automatic reset high pressure switch
EEV	Electronic pressure relief valve
IHP	Intermediate high pressure switch
DHP	De-icing high pressure switch
RV	4-way cycle changeover valves
ISV	Injection valve
DRV	De-icing valve
ESV	Oil equalization valve
EP	Pressure transducer (evaporation pressure)
OCT	De-icing temperature probe (evaporator inlet)
OAT	Outdoor temperature probe
CDT	High discharge temperature
CST	Evaporation temperature probe
FFT	T1 transformer protection fuse (24V secondary circuit)
T1	Ambience terminal 230/24V power supply transformer
WFL	Flow meter (water flow measurement)
WPR	Water pressure sensor
WP	Water pump
kWP	WP water pumprelay
EWT	Inlet water temperature probe
LWT	Outlet water temperature probe

→ **Options**

DZ WP/2	Dual zone water pumps
DZ MV	Dual zone mixer valve
AEH1	Backup electric heating (Stage 1)
AEH2	Backup electric heating (Stage 2)
BOILER	Hot water boiler (ON dry switch)
DHW WP	Domestic Hot Water circulation pump (kit with plate exchanger)
DHW V	Domestic Hot Water 3-way valve
DHW EH	Domestic Hot Water tank electric heating resistance
BR V	Substitute Boiler 3-way valve
DZWT	Dual zone water temperature probe (Under-floor heating outlet)
DHWT	Domestic hot water temperature probe
SPWT	Swimming pool water temperature probe
ON/OFF	Remote ON/OFF switch (Summer/Winter parameter settings)
LS	Off-peak hours electricity contact (DHW)
EMH	Backup heating switch (electric heater and boiler substitution)

→ Contactor fuse ratings, nominal currents settings (class AC3/AC1)

Supply voltages		3N~400V +/-10% 50 Hz		
		PAC HT 12-6	PAC HT 14-7	PAC HT 18-9
Only PAC HT General protection fuse rating (not supplied) aM type (1)		16 A	16 A	20 A
FUSE RATINGS				
FFC	aM type	6 A	6 A	6 A
FFT	T type	1.6 A	1.6 A	1.6 A
THERMO-MAGNETIC CUT-OUT SWITCH				
FT1	Range	9 - 14 A	9 - 14 A	9 - 14 A
	Setting	10 A	11 A	13 A
FT2	Range	4 - 6.3 A	4 - 6.3 A	4 - 6.3 A
	Setting	4.2 A	5.1 A	5.6 A
CONTACTORS				
K1		12 A	12 A	/
K2		9 A	9 A	9 A

Supply voltages		230 V +/-10% 50 Hz	
		PAC HT 12-6	PAC HT 14-7
Only PAC HT General protection fuse rating (not supplied) aM type (1)		32A	32A
FUSE RATINGS			
FF1	aM type	25A	25A
FF2	aM type	12A	16A
FFC	aM type	6A	6A
FFT	T type	1.6A	1.6A
CONTACTORS			
K2		12A	/

(1) These values are provided for information purposes only and must be checked and adjusted in relation to currently applicable standards. They vary depending on the type of installation and the choice of conductors.

[ELECTRICAL CONNECTIONS]



WARNING

Before carrying out any work on the equipment, make sure that the electrical power supply is disconnected and that there is no possibility of the unit being started inadvertently.

Non-compliance with the above instructions can lead to injury or death by electrocution.

The electrical installation must be performed by a fully qualified electrician, and in accordance with local electrical standards and the wiring diagram corresponding to the unit model.

Any modification performed without our prior authorisation may result in the unit's warranty being declared null and void.

The power supply cable section must be sufficient to provide the appropriate voltage to the unit's power supply terminals, both at start-up and under full load operating conditions.

The use of under-sized power supply cables can lead to major losses of around 100W to 200W.

The power supply cable shall be selected in accordance with the following criteria:

1. Power supply cable length.
2. Maximum unit starting current draw – the cables shall supply the appropriate voltage to the unit terminals for starting.
3. Power supply cables' installation mode.
4. Cables' capacity to transport the total system current draw.

Short circuit protection shall be provided. This protection shall comprise fuses or circuit breakers with high breaking capacity, mounted on the distribution board.

If the planned installation includes an ambience terminal, the latter must be connected with shielded cable which must not run through the same conduits as the power supply cables, as the possible voltage generated could cause a unit operating fault.

■ PHASE SEQUENCE AND CUT-OUT CONTROLLER

→ **Very important:**

3N~400V-50Hz

The outdoor unit is equipped as standard with a phase sequence and cut-out controller located in the electrical box.

THE LED'S INDICATE THE FOLLOWING CONDITIONS:

Green LED = 1 Yellow LED = 1	Green LED = 1 Yellow LED = 0	Green LED = 0 Yellow LED = 0
Power ON	Phase inversion or phase absent (L1)	Phase absent (L2 or L3)
The compressor rotation direction is correct.	The compressor and the fans do not start.	The compressor and the fans do not start.

■ PROGRESSIVE START-UP

3N~400V-50Hz

The **PAC HT 18-9** is equipped with a progressive starter (soft start) for the C1 compressor. The starter is situated in the electrical box of the outdoor unit and marked "AS1".

It is important to check the following settings:

- Start slope..... 1s
- Stop slope..... 0s
- Minimum starting voltage 60%

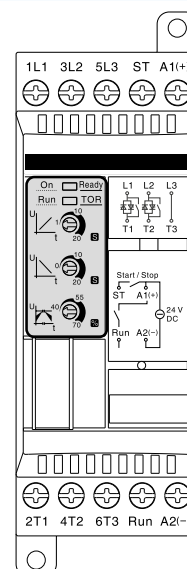
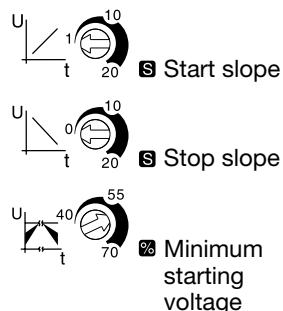

230 V +/-10% 50 Hz

→ **Important:**

The compressors are equipped with a soft starter. The starter is situated in the electrical box of the outdoor unit and marked "AS1/2".

THE LED'S INDICATE THE FOLLOWING CONDITIONS:				
Green diode	Red diode	Meaning	Recommended action	Comments
On	Off	No fault		
Off	Off	No supply voltage present at starter terminals.	Check the power supply to the PAC. Check the condition of the 230V protection fuse. Replace the fuse if it has melted.	
Flashing	Off	Insufficient supply voltage (compressor stopped).	Measure the compressor starter supply voltage at rest. Cut the power supply to the PAC and check whether or not the fault reappears. Refer to the following cause in the event of repeated failure.	
		Defective starter power supply component.	Cut the power supply to the PAC. If the fault persists, replace the starter.	
On	Flashing twice ■ ■	Insufficient compressor starting voltage (<190V).	Check the mains supply voltage at rest. Contact the electricity supplier if < 207V.	The alarm resets itself automatically after 5 min. If the fault re-occurs during the next start-up procedure, the compressor seizes and the power supply has to be disconnected to reset it.
			With the compressor running, check the mains supply voltage and the starter output voltage. In the event of major voltage drop, check the diameter of the PAC power supply cable. As a last resort, contact the electricity supplier.	
On	Flashing 3 times ■ ■ ■	Excessive compressor starting current.	Force the compressor to start several times and check whether it is a one-off or recurring fault.	The alarm resets itself automatically after 5 min. If the fault re-occurs during the next start-up procedure, the compressor seizes and the power supply has to be disconnected to reset it.
			If the fault persists, when the compressor is running, check for normal current draw. In the event of excessively-high current draw, replace the compressor.	
			Starter fault. Replace the starter.	
On	Flashing 4 times ■ ■ ■ ■	Starter internal condenser	Replace the starter.	
On	Flashing 5 times ■ ■ ■ ■ ■	Incomplete or defective compressor starting sequence	Force the compressor to start several times and check whether it is a one-off or recurring fault.	The alarm resets itself automatically after 5 min. If the fault re-occurs during the next start-up procedure, the compressor seizes and the power supply has to be disconnected to reset it.
			In the event of a persistent fault, check the compressor power supply cable.	

■ CONNECTIONS

Remove the inspection cover to gain access to the electrical connection box.

Pass the power supply cable through the cable passage provided on the appliance.

Install end fittings suitable for the cable section to ensure a good contact. Make the connections as shown.

→ Mains power supply

A circuit breaker or fuse holder (not supplied) must be installed on the main power supply of the unit in accordance with the circuit diagram; for the ratings, refer to the electrical specifications.

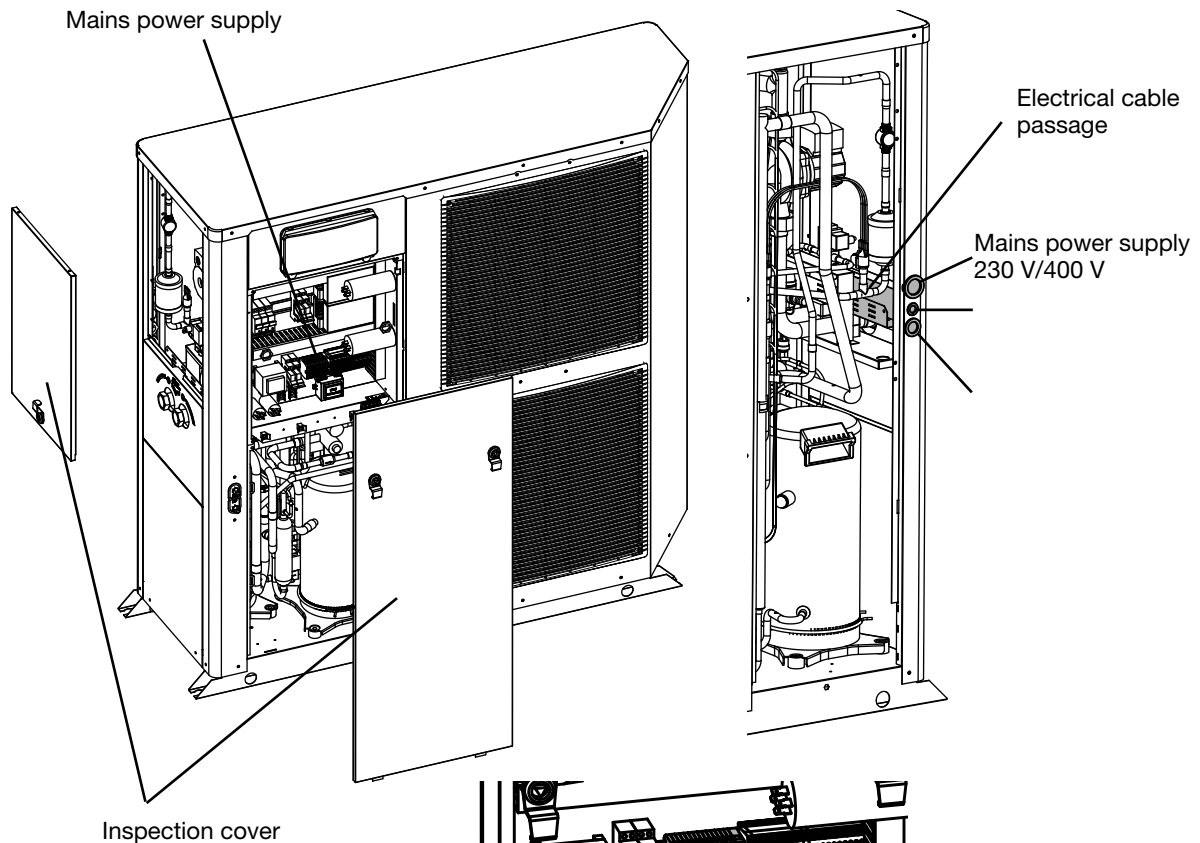

Inspection cover

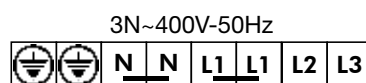
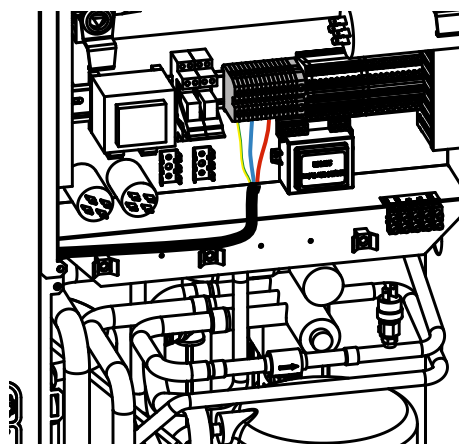

Mains power supply 400 V

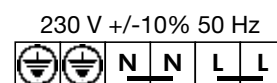

Mains power supply 230 V

→ **Ambience terminal**

2 separate cables for power supply (24V) and communication (A-B-GND).

Power supply 24V: Single pair cable 1 mm²

Communication: Shielded twisted single pair cable with screen 0.33 mm² to 0.5 mm² (AWG 20/22)

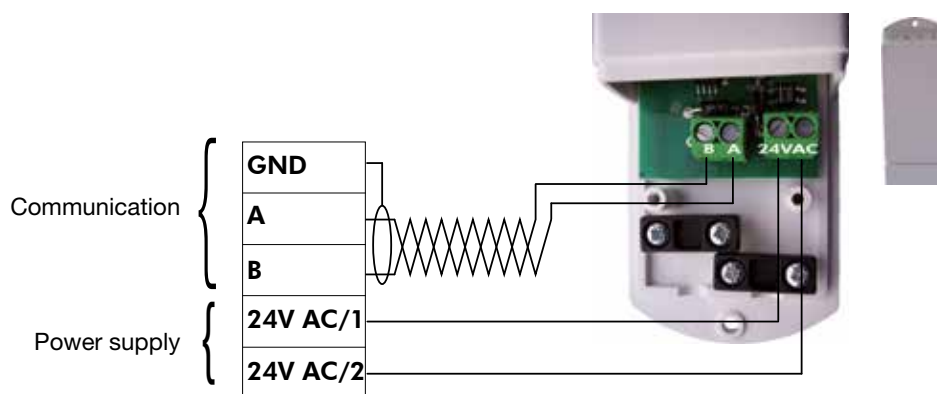
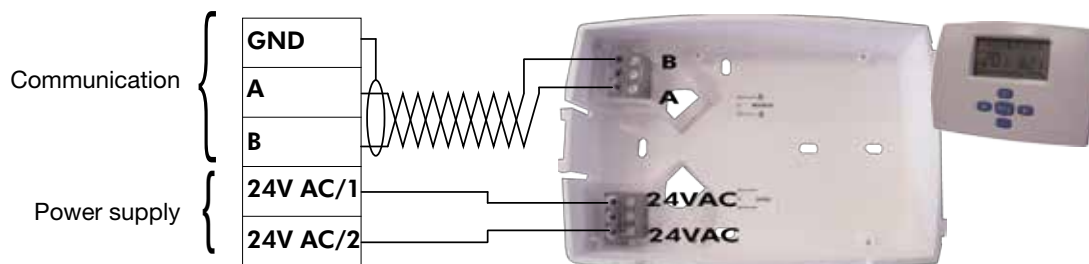
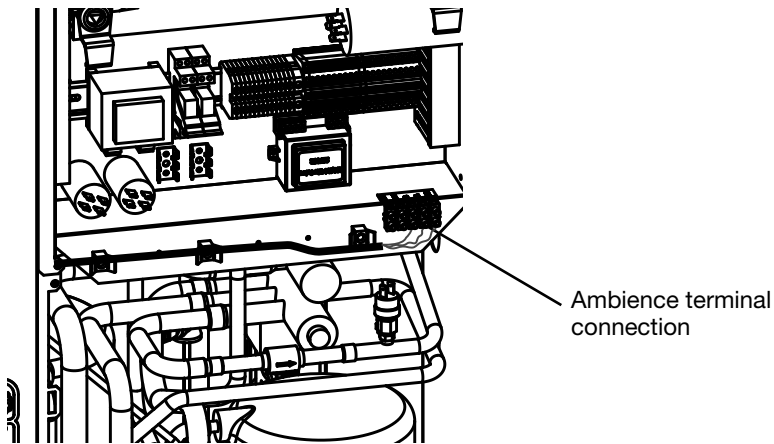

[DOMESTIC HOT WATER]

■ CONNECTION TO THE CENTRAL HEATING LOOP

An On-Off 3-way valve directs hot water produced by the **PAC HT** to either the heating circuit or the domestic hot water tank. Hydraulic connections must be made in accordance with the circuit layout diagrams provided.

Warning: You must ensure that the 3-way valve orifices (marked A, B and AB) are connected correctly to the circuit in order for the valve to operate in accordance with the electrical diagram provided.

→ 3-Way heating / domestic hot water valve

Fit the valve in accordance with the flow direction marks etched on the valve.

THE CONNECTIONS MUST CORRESPOND EXACTLY WITH THE FLOW DIRECTIONS INDICATED ON THE LAYOUT DIAGRAM FOR THE TYPE OF INSTALLATION.

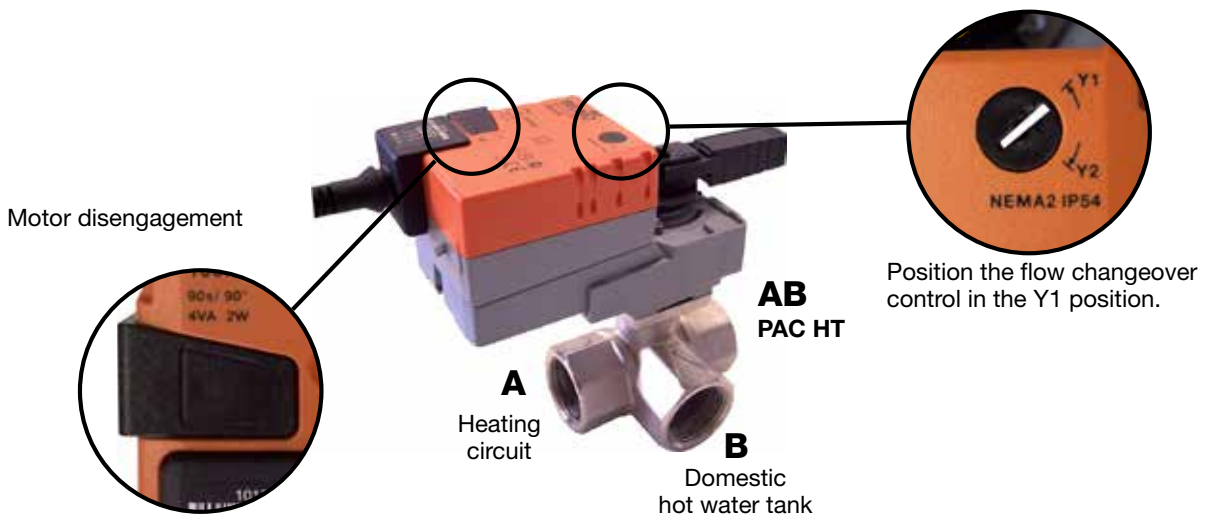

→ Electrical connections

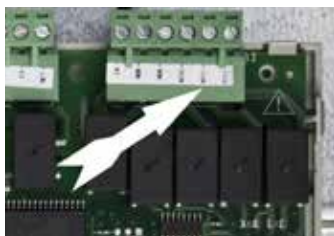
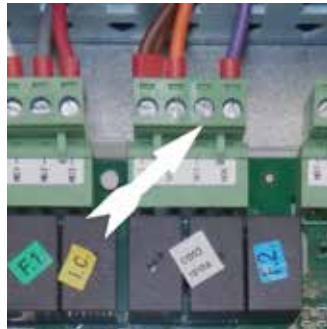
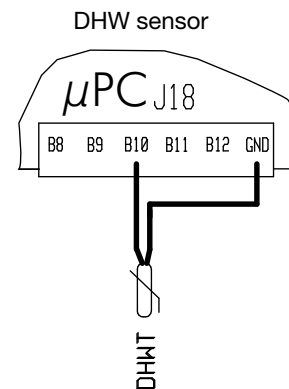
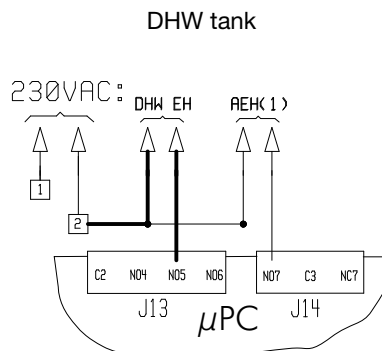
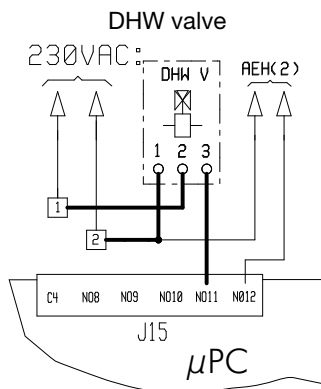

DOMESTIC HOT WATER PRODUCTION MODES

The PAC HT controller manages domestic hot water production in accordance with the following operating modes:

→ Permanent comfort mode

Domestic hot water production has priority over heating except when the ambience temperature / set temperature difference is greater than 2° C (Maximum one hour).

Example: Set temperature = 20°C, Ambience < 18°C

→ Economy mode

Domestic hot water is produced during off-peak hours (dry contact) or in accordance with times programmed in the controller.

Option: Possibility to restart domestic hot water production outside off-peak hours if the water temperature has reached a programmable minimum temperature.

→ Immediate domestic hot water production

The PAC HT 's regulator enables domestic hot water production to be forced as required. At the end of the cycle, the system returns to its usual operating mode.

The Legionnaires' Disease protection treatment managed by the PAC HT 's controller is fully programmable (frequency, temperature threshold, treatment length).

The PERMANENT COMFORT and ECONOMY modes place priority on thermodynamic heating. In the event of excessive demand for Domestic Hot Water Temperature that does not permit the compressor(s) to operate, the backup electric heating function is activated. In order to achieve energy savings, it is important to use the lowest possible set temperature points.

We recommend:
ECO SET TEMPERATURE < COMFORT SET TEMPERATURE < 53°C

DOMESTIC HOT WATER HEATING FUNCTION ACTIVATION

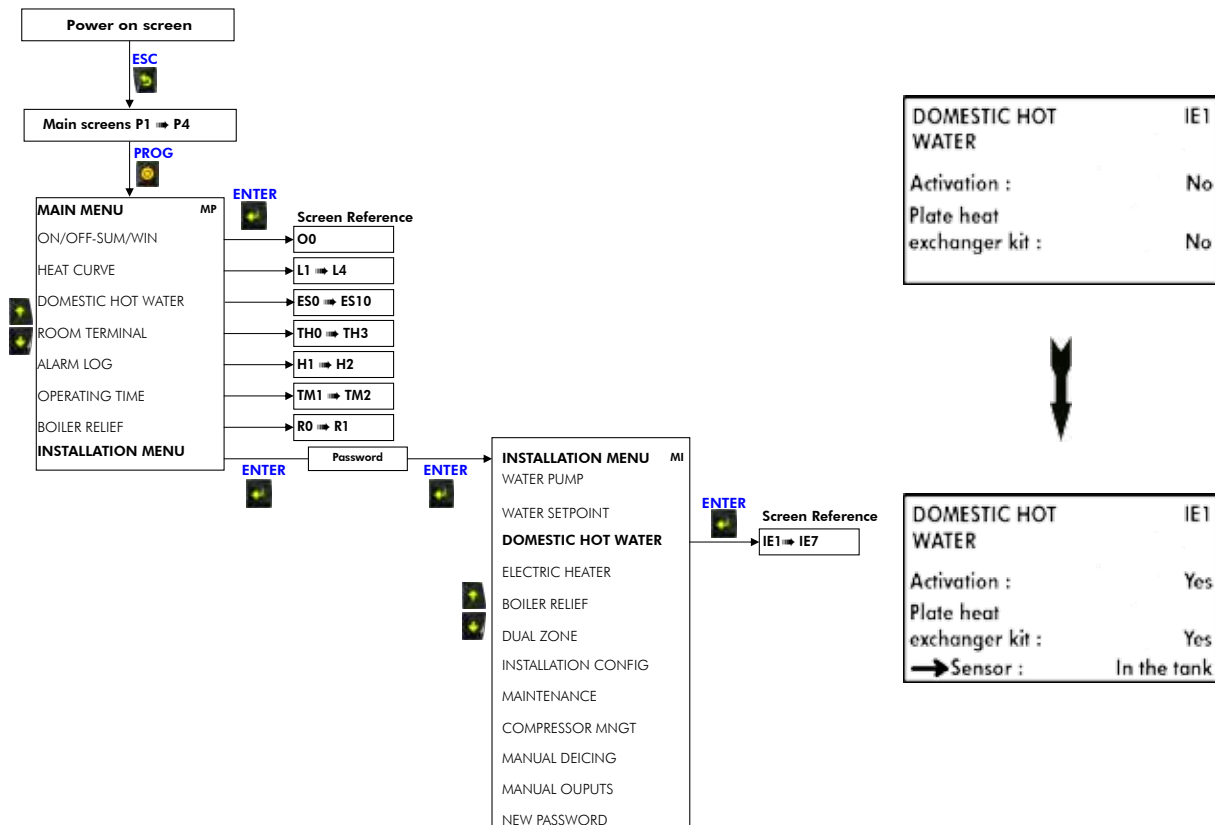

[IN-LINE ELECTRIC HEATER]

■ ELECTRICAL CONNECTIONS

→ See Appendix

■ OPERATING MODE

Operating parameters for these modes can be set via the display on the **PAC HT** .

→ Boost mode

The backup electric heating offers additional capacity when the demand for heating is higher than the capacity of the **PAC HT**. The aim is to maintain occupant comfort, while favouring thermodynamic operation for optimised performance.

The resistances are only activated below a certain outdoor temperature (values can be set for Stage 1, AEH1 and Stage 1+2, AEH1+AEH2) and only if the **PAC HT** regulation system detects a lack of capacity in compressor only mode (check on water temperature and ambient temperature).

Activation of the EMH Back-up switch on the heater switches the **PAC HT** into Back-up mode.

→ Back-up mode

As opposed to Booster mode, this mode operates only when the user activates the EMH Back-up switch (this supposes an alarm on the **PAC HT**). Outdoor temperature conditions are overridden and priority is no longer given to the thermodynamic mode but to the heating resistances that are nevertheless still controlled by the **PAC HT**.

■ ELECTRIC HEATER FUNCTION ACTIVATION

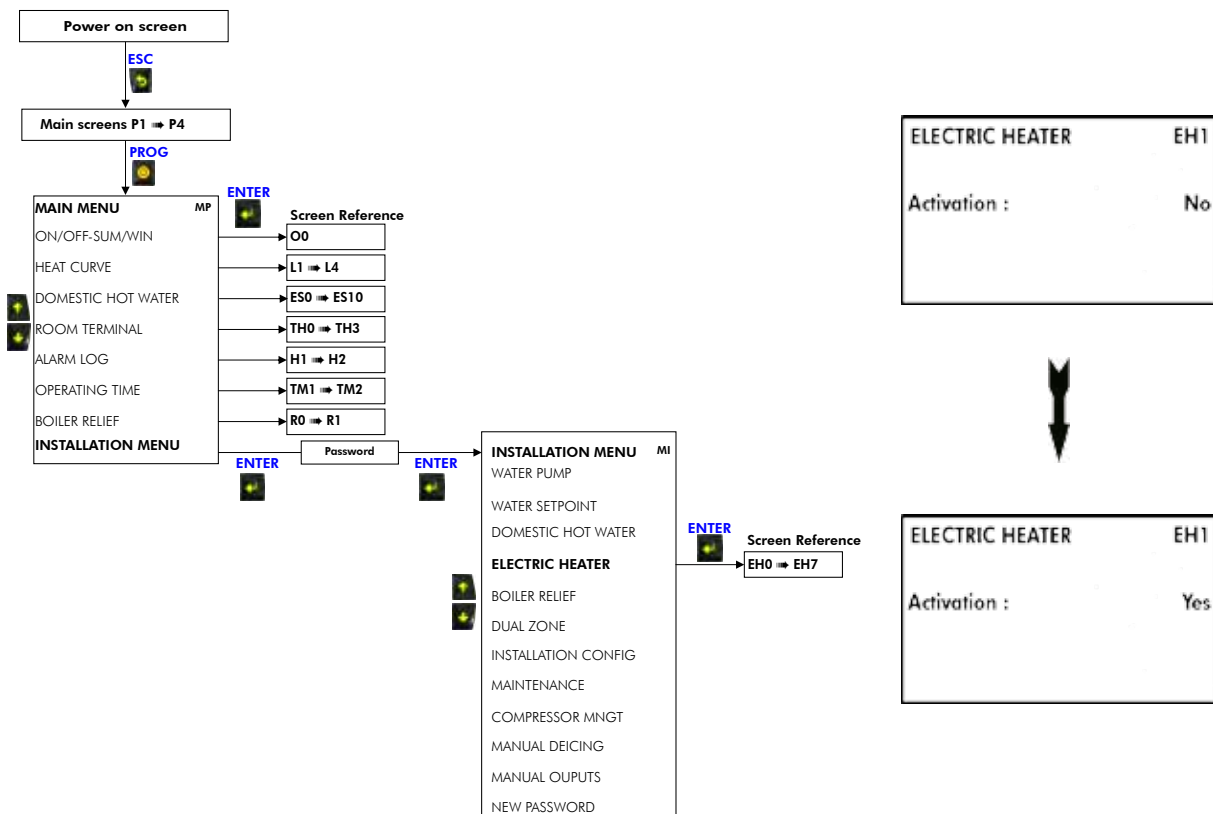

[BOILER RELIEF]

■ ELECTRICAL CONNECTIONS

The boiler relief function uses the digital outputs of the in-line electric heater function to control the hot water boiler ON/OFF switch (Boiler dry contact switch) as well as a 3-way valve output (230V BRV). A switch should be wired to the ICS input to ensure operation in Back-up mode.

■ OPERATING MODES

Operating parameters for these modes can be set via the display on the **PAC HT**.

→ Boost mode

Hot water boiler operation is only authorised below a certain set outdoor temperature value and the appliance can also be placed in forced shutdown mode below a different outdoor temperature value. Just as the electric heater, the **PAC HT** continuously checks the water temperature and the ambient temperature to optimise compressor operation and to only start the hot water boiler when absolutely necessary.

The **PAC HT** can also be set to manage a heat curve on the hot water boiler higher than the temperature set for the appliance (65° C maximum).

→ Back-up mode

Activation of the EMH switch (to be wired by the installer) or the Back-up parameter, via the “Boiler Relief” tab on the main menu of the **PAC HT** display, switches the system into Back-up mode and both outdoor temperature and ambient temperature conditions are overridden.



We strongly recommend the installation of the ambience terminal for effective operation of the Boiler Relief function. In the absence of an ambience terminal the PAC HT will be unable to optimise hot water boiler operation and this will lead to unnecessary energy consumption.

■ BOILER RELIEF FUNCTION ACTIVATION

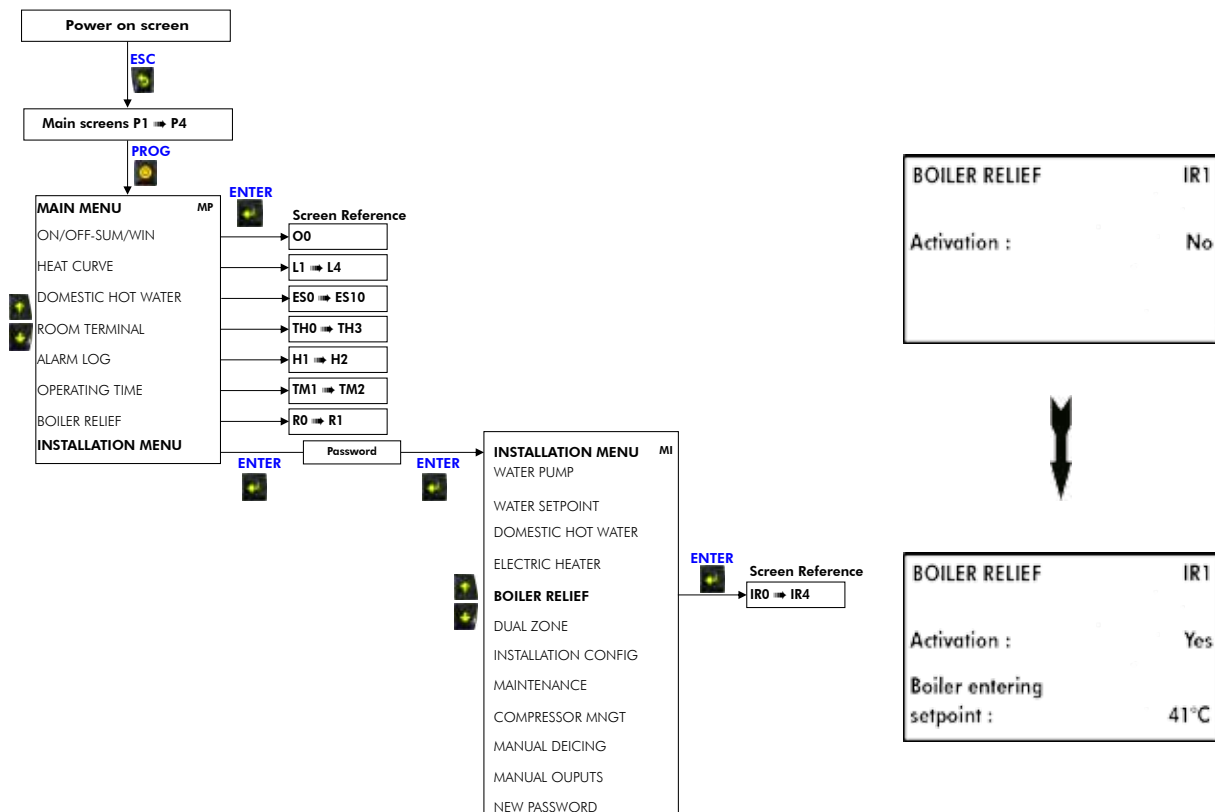

[DUAL ZONE]

■ ELECTRICAL CONNECTIONS

→ See Appendix

■ ACTIVATING THE DUAL ZONE FUNCTION

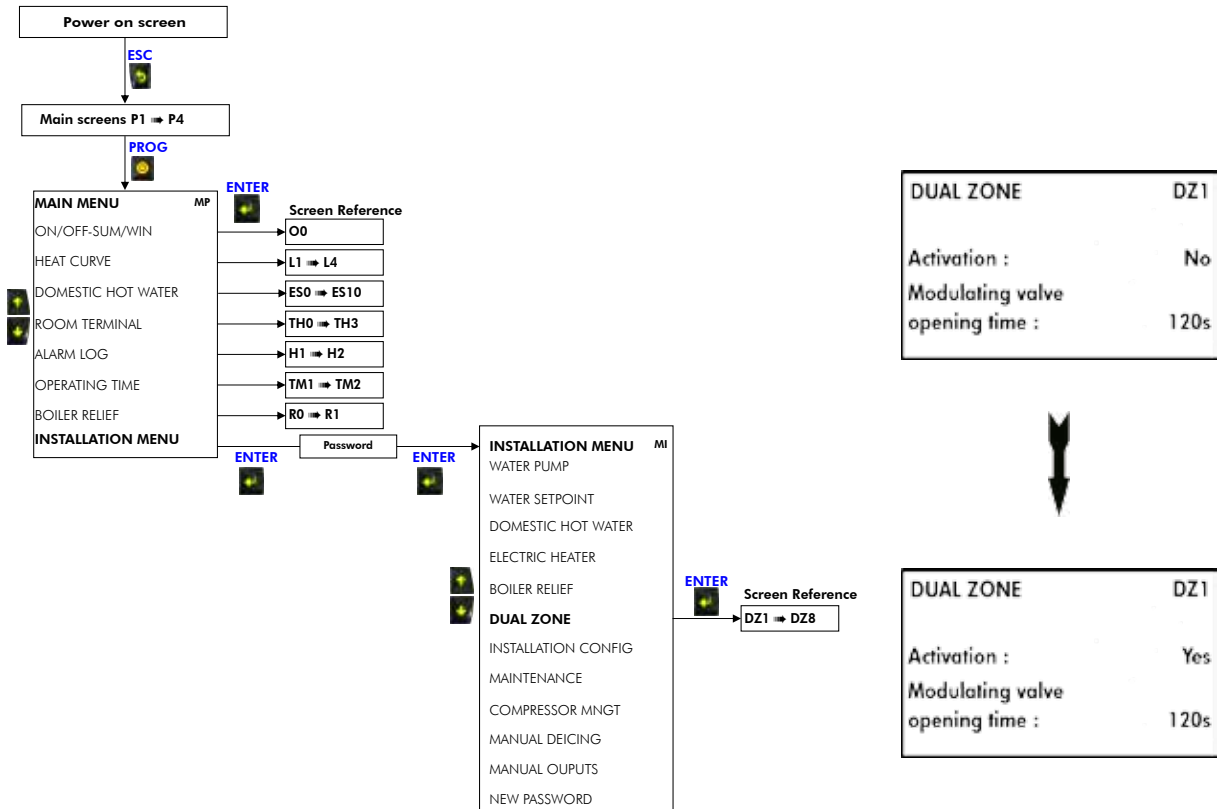

You MUST install one room terminal per zone.

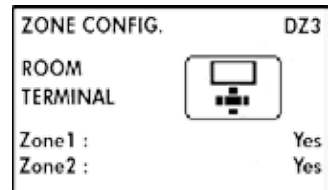

You must specify the type of emitter for each zone. Zone 1 corresponds to the low temperature zone. Setting the Aqu@Scop HT controls the water output temperature using the DZMV modulating valve and the DZWT temperature sensor.

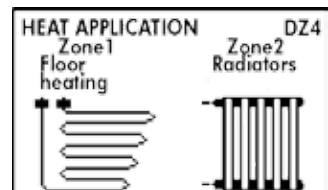

■ AMBIENCE TERMINAL

The double zone function requires the use of one ambience terminal per zone. You must specify one address per ambience terminal.

→ **Zone 1:** Address 1

→ **Zone 2:** Address 2



CHANGING THE AMBIENCE TERMINAL ADDRESS FOR ZONE 2.
See the communicating ambience terminal's installation manual (IOM WATTS 01-N-2ALL).

[COMMISSIONING]

■ PRE-START CHECK LIST

Before commissioning the system, you must carry out a certain number of installation checks to ensure that the appliance will operate in the best possible conditions. The following list of checks is not exhaustive and only serves as a minimum reference guide.

→ Visual check

1. Check free clearances around the unit, including the exchanger air intake and outlet, and access for maintenance work.
2. Comply with the free clearance dimensions around the domestic hot water tank.
3. Check unit assembly in accordance with specifications.
4. Check presence and tightness of all screws and bolts.
5. Check the position of the rubber anti-vibration pads or the vibration-absorbing supports.
6. Check that the unit is level and that condensates drain freely away from the unit.
7. Check that there is no possibility of blown air being recycled through the fans due to wind exposure.
8. In arduous climates (sub-zero temperature, snow, high humidity), check that the appliance is raised 10 cm off ground.
9. Check that the ambience terminal is located correctly (frequently occupied area, 1.5 m above ground level, etc.).
10. For refrigerant leaks in connections and components.

→ Electrical check

11. Electrical installation has been carried out according to unit wiring diagram and the Supply Authority Regulations.
12. Size fuses or circuit breaker has been installed at the main power supply.
13. Supply voltages as specified on unit wiring diagram.
14. Check the tightness of wire to component connections.
15. the cables and wires are clear of or protected from pipework and sharp edges.
16. Check the electrical grounding of the appliance.

→ Hydraulic check

1. Check that the external water circuit components (pumps, user equipment, filters, expansion tank and reservoir if supplied) have been correctly installed in accordance with the manufacturer's recommendations and that the water inlet and outlet connections are correct.
2. Check the presence, direction and position of the water filter upstream of the appliance. Rinse the filter after the first 2 hours of operation.
3. Check that the water quality complies with stated standards.
4. Check that the hydraulic circuit is filled correctly and that the fluid flows freely without any signs of leaks or air bubbles.
5. Adjust the water flow in order to comply with the specifications. (Refer to the § WATER FLOW REGULATION, page 21)
6. Check the presence and position of the stop cocks to isolate the appliance for maintenance.
7. Check the presence of the air bleed valve.
8. Check protection against freezing (heat isolation, antifreeze percentage if required...).
9. Check that the bleed valve in the appliance has been opened.

[STARTING THE APPLIANCE]

After checking all the electrical connections and making any rectifications as required, proceed with starting up the installation.

■ USER INTERFACE

The terminal is a 6-button, 8-line x 22-character LCD model, which can display text in various sizes and icons.



→ Keypad

ALARM  :

When you press the Alarm key (the red bell is apparent if an alarm is active), the first active alarm is displayed on the screen and the screen buzzer is switched off (if active). Use the UP/DOWN keys to view all the active alarms. Press the Alarm key a second time to cancel all alarms that can be cancelled in this manner. Alarms that remain active are still displayed. If no alarm is active, pressing the key returns the system to the “NO ALARM ACTIVE” screen.

ESC  :

Moves to previous level in the menu arborescence. Press this to change an analogue or integer variable, such as 34.5 for example (as opposed to a digital variable such as Yes/No), to cancel the current change and return to the previous menu. This function is very important if a parameter is changed by mistake.

PROG  :

From any screen, this key returns to the main menu. Just as the ESCAPE key, this key cancels the current change.

UP/DOWN   :

These keys have several functions:

In a menu, they enable you to scroll through the list of available selections.

When the cursor is placed in the top left hand corner of the screen it is possible to scroll through the screens available in this arborescence.

Finally, these keys enable you to change the value of a parameter when the cursor is placed on the parameter in question.





ENTER  :

On those screens where it is possible to change one or several parameters, the first press on the key moves the cursor to the first parameter on the screen. A second press validates the current parameter and the cursor scrolls to the following parameter until it returns to the upper left hand corner.

→ Backlighting

All the screen keys are backlit.

The ALARM key diode lights up when at least one alarm is active. The  key is lit when you are in the main menu or in one of its sub-menus.

The  ,  ,  and  keys light up along with the display backlighting.

If no key is pressed during a 5 minute period, the display automatically reverts to the first main screen (P1) and all backlighting is switched off.

→ Menus

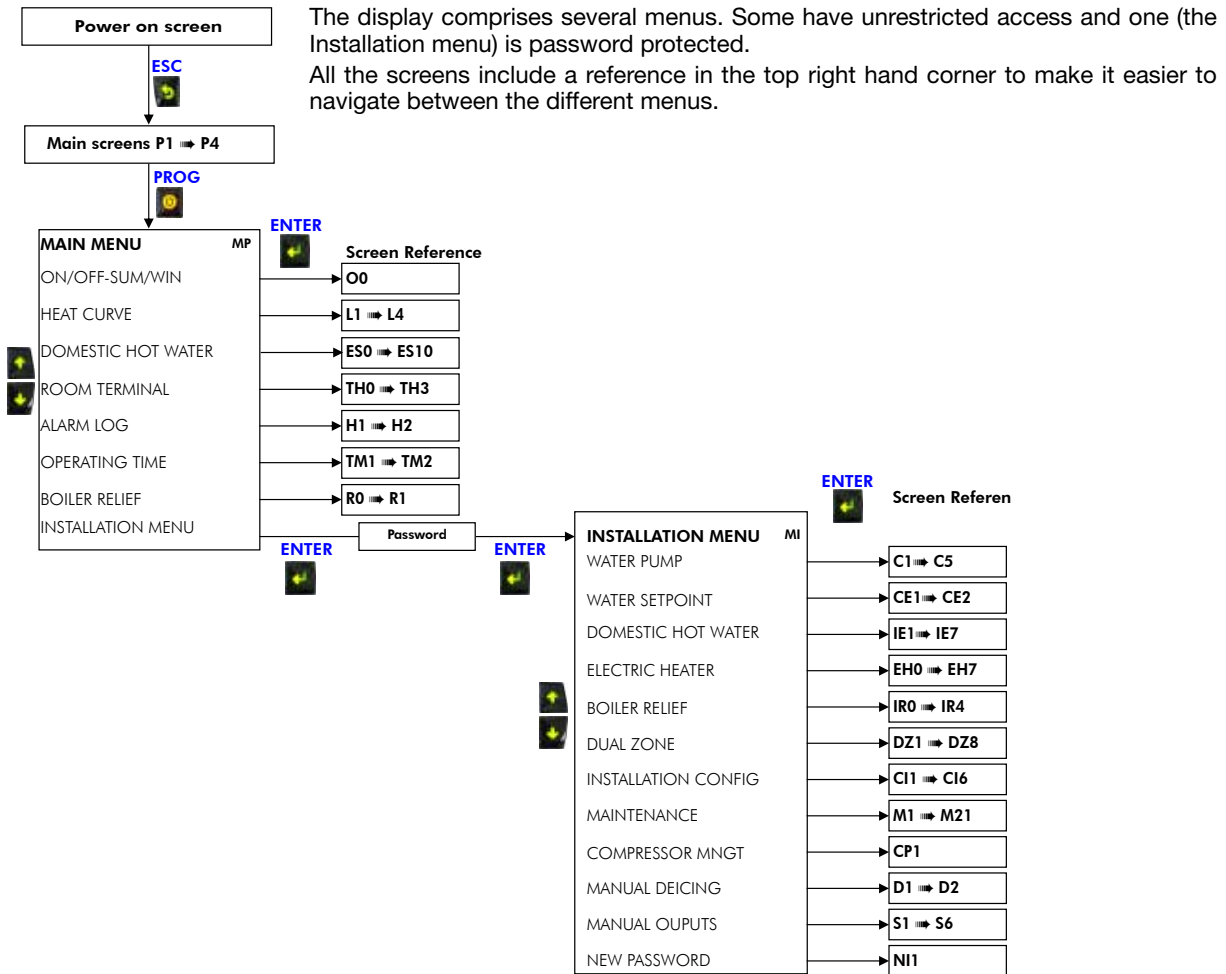

→ Icons

P1		Outlet water set temperature, calculated from the heat curve parameters, the outdoor temperature, the ambience set temperature and the variance between the set and the ambience temperature.
		Compressor 1 (large) in operation - Flashing => Compressor in time delay
		Compressor 2 (small) in operation - Flashing => Compressor in time delay
		Fan 1 (upper) in operation
		Fan 2 (lower) in operation
		Outlet water temperature
		Inlet (return) water temperature
		PAC HT in Summer mode
		Flashing: Countdown for de-icing Fixed on: De-icing in progress
		Circulation pump in operation
P3		Instantaneous outdoor temperature
		Reference outdoor temperature used by the PAC HT (upper fan special management)
		Evaporator inlet temperature (used for calculating the length of the de-icing time period).
		Domestic hot water temperature (when the option is installed)
		PAC HT in domestic hot water production mode (flashing)
		Electric heater Stage 1 in operation (flashing)
		Electric heater Stage 2 in operation (flashing)
		Hot water boiler in operation (flashing)

■ SIMPLIFIED START-UP PROCEDURE

→ Main screens

On the **PAC HT** display, after having checked the coherence of the temperature probes on the main screens P1, P2 and P3, as well as effective communication with the ambience terminal, it is advisable to set the heat curve parameters before starting the **PAC HT**. The main screen P1 is accessible by pressing the key  several times. The main screen P1 also appears after 5 minutes of display inactivity.

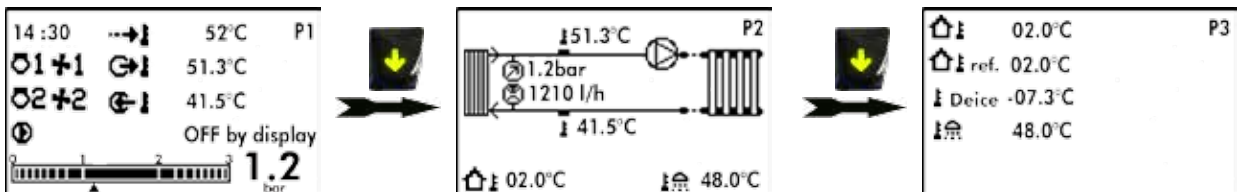

→ Installation configuration

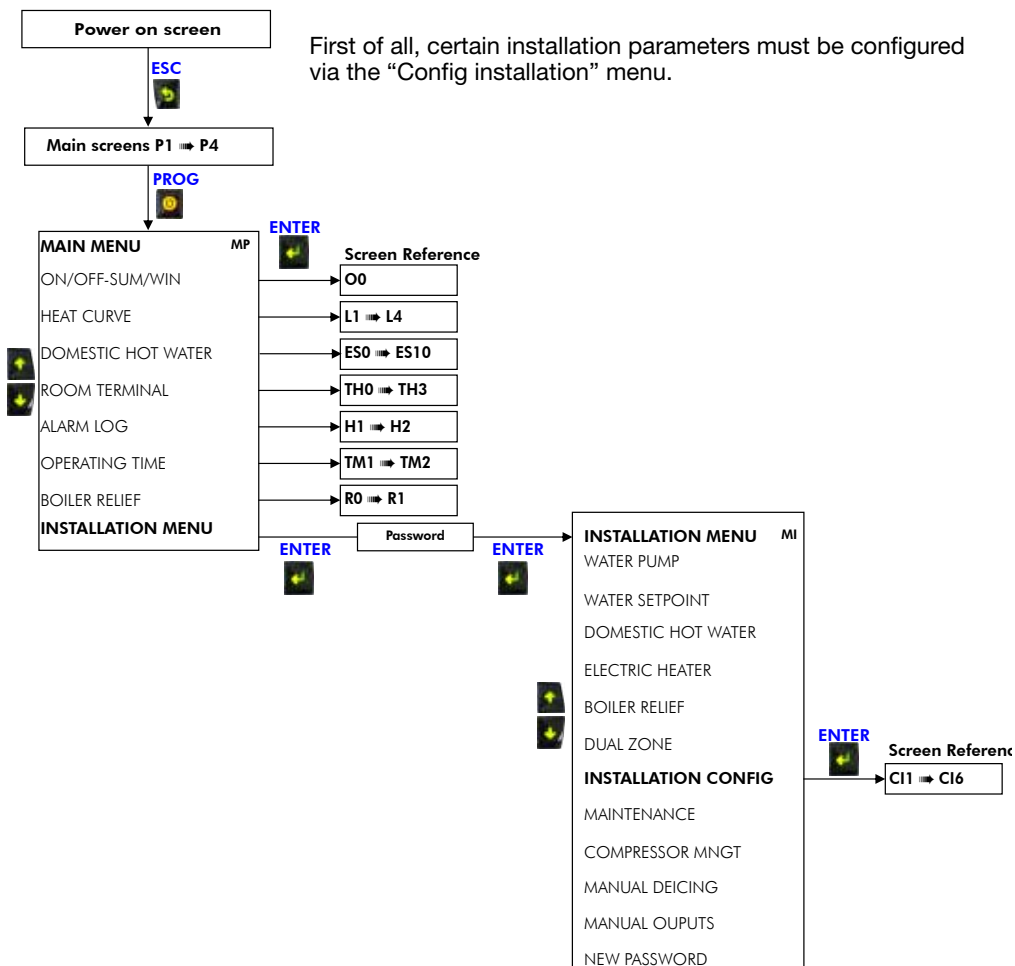

C11 Configuration of the type of heating emitter: radiators or under-floor heating. Changing this parameter automatically leads to changes in the water law parameters. It is very important to configure this parameter before making any alterations whatsoever to the water law parameters and before starting the **PAC HT** for the first time.

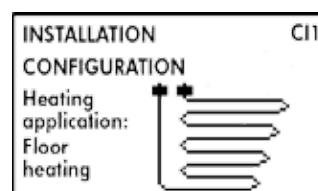
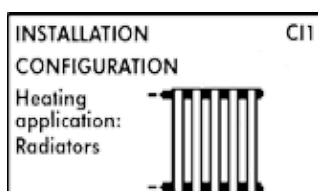

CI2 Outdoor temperature probe. This probe should not be installed remotely.

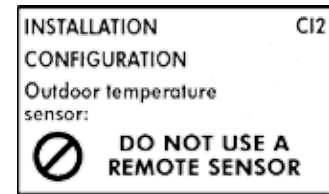

CI3 Ambience terminal Activation/deactivation (Default setting: activated). The temperature differential parameters in relation to the set ambient temperature control the starting and stopping of the **PAC HT** in terms of ambient temperature (even though the water law is also managed by ambient temperature conditions). As a default setting, the PAC will stop at the set ambient temperature + 1°C and restart at the set ambient temperature + 0.5°C (this enables the installation to anticipate any drop in ambient temperature and avoid excessive temperature fluctuations).

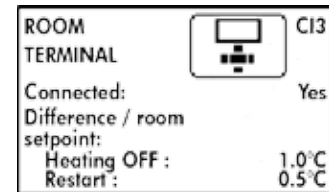
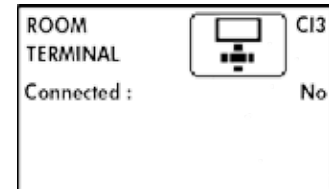

CI4 Configuration of the remote all or nothing ON/OFF input. Refer to the Indoor unit wiring diagram.

In ON/OFF configuration, this input enables the **PAC HT** to be stopped completely. When the boiler substitution function is activated, switching to OFF automatically activates the boiler. It is possible to configure this input as Normally Open or Closed (Default setting: NO).

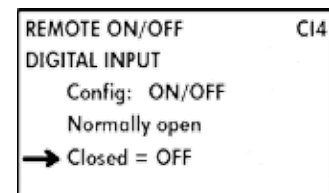

In SUMMER/WINTER configuration, this input stops the Heating function while maintaining the DHW function active (equivalent to the ambience terminal switching to OFF). NO (Normally Open) or NC (Normally Closed) configuration is also possible.

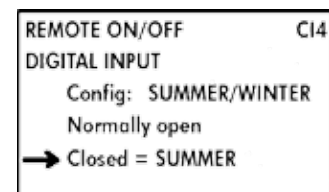



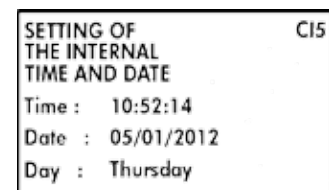

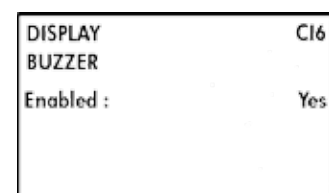

CI5 Refer to the § TIME AND DATE VERIFICATION.



CI6 Display buzzer authorisation in the event of an alarm (Default setting: authorised).



→ **Heat curve parameters**

On the main menu (key ) , use the  /  arrows to highlight the “HEAT CURVE” menu. Validate this selection with the  key. This moves the display to the L1 screen. Use the  and  /  keys to set the following parameters:

Screen L1

HEAT CURVE	L1
Altitude :	0.0 km
Base outdoor temperature :	-07°C
Correction Coef. :	0.8

Altitude: Installation site altitude, in km (e.g. 0.5km equals 500m. Default setting: 0).

Base outd. T.: Typical outdoor temperature for the installation region (Default setting: -7°C).

Corr. Coef.: Correction Coefficient for the base of the slope. This is a simple way of changing the water set temperature (Default setting: 0.8).

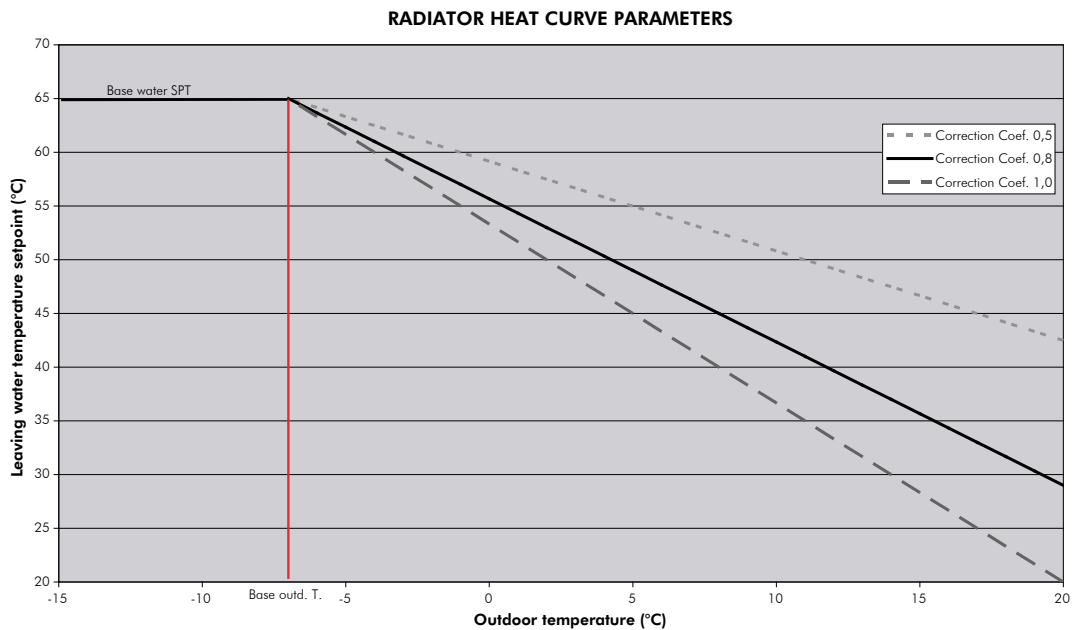

Screen L2

HEAT CURVE	L2
Heat loss at base outdoor temperature :	12.9kW
Water outlet at -7°C outdoor :	65°C

Losses at base Outdoor Temp : Estimated heat loss for the dwelling for an ambient temperature of 20°C and a base outdoor temperature (e.g. -7°C). This parameter is used to calculate the outdoor temperature that triggers the change from small compressor mode to two-stage compressor mode. This value is capped at the maximum capacity of the **PAC HT** model in question for this same outdoor temperature (Default value = Maximum value).

Water outlet temperature at -07°C Outdoor temperature : Outlet water temperature required at the base outdoor temperature (-7°C for example) to have an ambient temperature of 20°C (Default setting: 65°C).

Screen L3

Outdoor temperature balance point	L3
DEFAULT	
$C2\{small\} / C1+C2$	
06.0°C	

Information screen for the outdoor temperature calculated automatically by the **PAC HT** . With the preceding default parameters, the value of 5.4° C means that below an outdoor temperature of 5.4° C the **PAC HT** will start the large compressor or the two-stage compressor. Above 5.4° C the **PAC HT** will start the small compressor.

Screen L4

Outdoor temperature balance point	L4
AUTOMATIC	
$C2\{small\} / C1+C2$	
06.0°C	
Reset:	No

The value of the outdoor balance temperature displayed on L4 is the one updated by the **PAC HT** after running for some time, in the event that the **PAC HT** detects a lack of capacity with the small compressor.

Zero reset: This is required in the event of changes to the heat curve parameters in order for the **PAC HT** to register these changes. The parameter on screen **L3** is then recopied into screen **L4**.

→ **Verification of communication with the communicating ambience terminal**

Screen TH1

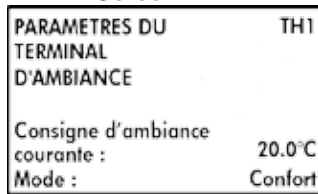

By default, the ambience terminal is declared in the regulator. This means that an alarm will be visible on the screen of the **PAC HT** a few seconds after the power supply is switched on, if the terminal is not connected. Proper terminal operation can be checked on screens TH1 to TH3.

All the terminal parameters are accessible via the “Ambience Terminal” menu in the main menu (key ).

Screen TH0



Screens: TH0 to TH3.

The screen TH0 appears when the terminal is deactivated (installation menu) or disconnected. This screen provides access to a set temperature to facilitate the inputting of water law offset values.

→ **Compressor sump heater function activation**

After the first power ON (compressors OFF), and for any outdoor air temperature, manually switch ON the compressor sump heaters.

Before starting the compressors, the sump heaters must be powered On for at least 2 hours in order to evaporate any liquid refrigerant that could be in the compressors to ensure their lubrication at the first start-up.

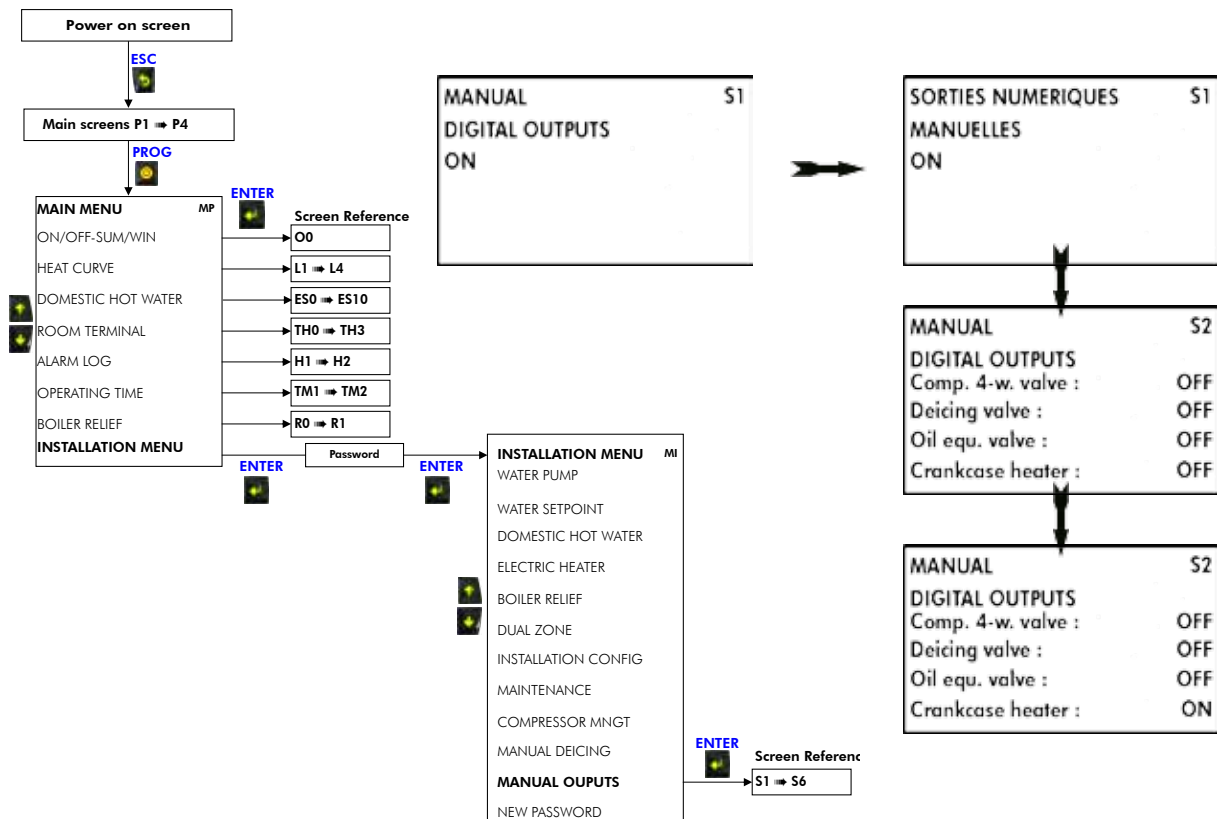

→ **Time and date verification**

The time and the date are used to manage the:
 - alarm log.
 - the DHW Legionnaires Disease protection function.

	TIME / DATE	P4
Time :	10:52:14	
Date :	05/01/2012	
	Thursday	

When a communicating ambience terminal is connected to the **PAC HT**, the time is automatically updated in the regulator. The date is managed solely by the regulator. At commissioning, check:
 The date, screen P4. Update as required in the “**Config installation**” CI5 menu.
 The time (screen P4) if no ambient terminal is connected. Update as required in the “**Config installation**” CI5 menu.

→ **PAC HT ON/OFF settings**

In order to start, the **PAC HT** must always be ON at the level of the appliance’s display. In addition, the ambience terminal must be in demand mode (when it is connected). To force the terminal to enter demand mode, change it to Comfort mode  with an ambience temperature set at 30° C.

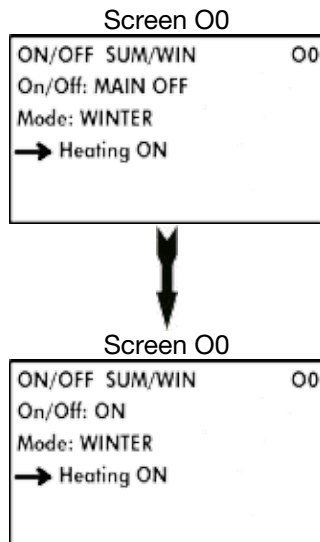

The appliance OFF function will always have priority and therefore you will never be able to start the **PAC HT** in this mode.







From the main menu, use the  /  arrows to highlight the “ON/OFF-SUMMER/WINTER” menu. Validate this selection by pressing the  key.

The display moves to the O0 screen.

Press the  key twice to move the cursor to the GENERAL OFF parameter.

Use the  /  arrows to change this parameter to ON.

Press  to validate and then on the key .

If the ambience terminal is in demand mode, and if no alarm is active and the water temperature condition permits (inlet water  at least 7° C below set temperature ) , the **PAC HT** will start operating.
 Normal **PAC HT** operation is guaranteed with an appliance inlet (system return) water temperature above 20° C.

■ OPERATING CHECK LIST

→ General

Check for any unusual noises or vibration in the running components, particularly the fan drive system.

→ Phase rotation protection

If the phase of the power supply are not correct, the phase rotation protection device will prevent the machine from starting.

→ Electrical

OPERATING VOLTAGE	Recheck voltage at unit supply terminals.
CONTROL	Verify all sensor inputs, using the controller display.

→ Fan & drive

Check that the fans rotate freely, in a balanced manner without any rubbing.

→ Compressor and refrigeration system

1. Checking operation: Start the **PAC HT**. Check for any abnormal noises or vibrations.
2. After a few minutes operation, the evaporator outlet superheating should be:
 - 3K (±1K) with C2 compressor operating on its own,
 - 5K (±1K) with C1 + C2 compressors or C1 operating on its own. (*)

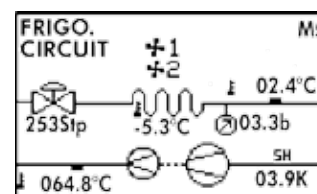

→ Final check

1. All panels and fan guards are in place and secured.
2. Unit clean and free of remainder installation material.

[FINAL TASKS]

Place the plugs back on the valves and check that they are properly tightened.

If needed, fix the cables and the pipes on the wall with clamping collars.

Operate the **PAC HT** in the presence of the user and explain all functions.

[IN CASE OF WARRANTY - MATERIAL RETURN PROCEDURE]

Material must not be returned without permission of our After Sales Department.

To return the material, contact your nearest sales office and ask for a "return form". The return form shall be sent with the returned material and shall contain all necessary information concerning the problem encountered.

The return of the part is not an order for replacement. Therefore, a purchase order must be entered through your nearest distributor or regional sales office. The order should include part name, part number, model number and serial number of the unit involved.

Following our personal inspection of the returned part, and if it is determined that the failure is due to faulty material or workmanship, and in warranty, credit will be issued on customer's purchase order. All parts shall be returned to our factory, transportation charges prepaid.

[ORDERING SERVICE AND SPARE PARTS ORDER]

The part number, the order confirmation and the unit serial number indicated on the name plate must be provided whenever service works or spare parts are ordered.

For any spare part order, indicate the date of unit installation and date of failure. Use the part number provided by our service spare parts, if not available, provide full description of the part required.

* These checks can be performed at the time of commissioning with the help of qualified technical personnel.

[MAINTENANCE]

The user is responsible for ensuring that the unit is in perfect working order and that the technical installation and minimum annual maintenance operations have been performed by a qualified technician in accordance with the procedures described in the present manual.



Some alarms can only be cancelled by switching the PAC HT to OFF. Generally, an alarm means that there is an anomaly present on the appliance. We strongly recommend that you refrain from repeatedly resetting an alarm without rectifying its cause in order to avoid the risk of causing irrevocable damage to one or several components.

Depending on actual operational constraints and regulatory changes, the installer might recommend increased maintenance operations and more frequent inspections.

WARNING: Isolate unit from power supply before working on unit.

■ SERVICING CHECKLIST

Carry out a visual inspection of the complete installation in service.

→ Outdoor unit

1. Clean the outer panels.
2. Remove the panels.
3. Check that the insulation is not damaged. Repair as required.

→ Condensate recovery tray

1. Check that the drainage orifices are not blocked.
2. Eliminate all accumulated dirt.
3. Check that no traces of rust are present.

→ Refrigeration circuit

1. Check the absence of gas leaks.



A control of gas leaks absence should be performed on this device at least once a year, by a qualified technician. Referred to national requirements for the frequency of such controls.

2. Check that the copper tubes or the capillary tubes do not rub against any metal or vibrate.
3. Check that the compressors do not generate any abnormal noises or vibrations.
4. Check the compressor discharge temperature.
5. Check that the crankcase heater is energised during the OFF cycle. (Switch on manually if necessary)

→ Fin exchanger

1. Clean the heat exchanger using a special product for aluminium-copper heat exchangers, and rinse with water. Do not use hot water or steam, as this could cause the pressure of the refrigerant to rise.
2. Check for signs of wear on the fan bearings.
3. Verify the condition of the fans and the motors.

→ Electrical equipment

Les interventions dans les boîtiers électriques sont réalisées par des techniciens habilités.

1. Check that the main power supply cable is not damaged or altered in such a way as to affect the insulation.
2. Check that the interconnecting cables between the two units are not damaged or altered, and that they are correctly connected.
3. Check the tightness of the screw terminals.
4. Check the general tightness of all cable connections.
5. Perform a visual check of the condition of the contacts.
6. Inspect the relay contact surfaces and the contractors and replace them if necessary.
7. Check nominal current draw and the condition of the fuses.
8. Clean the control box with compressed air to remove any build-ups of dust or dirt.
9. Check the earth grounding connection.

→ Protection devices

1. Check the proper operation of the high pressure protection devices.

→ Hydraulic circuit

1. Check that the hydraulic circuit is filled correctly and that the fluid circulates freely without any sign of leaks or air bubbles.
2. Inspect filter cleanliness.
3. Check water pressure and flow.



CAUTION

BEFORE CARRYING OUT ANY OPERATION ON THE EQUIPMENT, CHECK THAT THE ELECTRICAL POWER SUPPLY IS SWITCHED OFF AND THAT IT CANNOT BE SWITCHED ON INADVERTENTLY.

IT IS RECOMMENDED THAT THE DISCONNECT SWITCH BE PADLOCKED

[ALARM LIST AVAILABLE ON THE PAC HT DISPLAY]

Software version: 6.0

Some terms may differ depending on the software version.

Ref.	Alarm description	PAC HT action	Alarm cancellation	Time delay	Possible cause(s)	Recommended action(s)
AL01	Entering water temperature sensor disconnected or damaged	Complete shutdown	Manual	10 s	Disconnected or faulty sensor	Check the probe wiring, replace the probe if faulty.
AL02	Leaving water temperature sensor disconnected or damaged	Complete shutdown	Manual	10 s		
AL03	Outdoor temperature sensor disconnected or damaged	Complete shutdown	Manual	10 s		
AL04	Domestic hot water temperature sensor disconnected or damaged	DHW function stopped.	Manual	10 s		
AL05	Deicing temperature sensor (coil bend) disconnected or damaged	Thermodynamic function stopped completely.	Manual	10 s		
AL06	Lack of water flow, freezing risk	Complete stoppage and forced water circulation pump operation during stoppage	Manual	30s after start of circulation pump	Seized water pump	Check water pump operation
					Clogged water filter.	Clean the filter.
					Water flow too low or air in the system	Check the PAC's temperature difference in operation. Increase the flow (change the water pump speed)
AL07	Double zone temperature sensor disconnected or damaged	Radiator zone stoppage, under-floor heating water law, modulating valve 100% open.	Manual	10 s	Probe disconnected or faulty.	Check the probe wiring, replace the probe if faulty.
AL08	Outdoor fans fault	Thermodynamic function stopped completely.	Manual	None	Internal temperature protection cut-out in one of the fans	Reset the alarm after allowing the motors to cool. Check which fan is overheating. Replace the defective fan.
AL09	Compressor 1 / big overload	Automatic changeover to C2 compressor WARNING: De-icing impossible.	Manual (PAC HT OFF via keypad)	None	Thermo-magnetic circuit breaker tripped (three phase)	Reset the circuit breaker. Check that the setting corresponds to specifications
AL10	Compressor 2 / small overload	Automatic changeover to C1 compressor	Manual (PAC HT OFF via keypad)	None	Thermo-magnetic circuit breaker tripped (three phase)	Reset the circuit breaker. Check that the setting corresponds to specifications
AL11	High pressure lockout	Complete thermodynamic function stoppage (no manual reset).	Manual (PAC HT OFF via keypad) after at least 2 minutes stoppage	None	Refer to the fault diagnosis guide in the Installation and Maintenance Manual	Refer to the fault diagnosis guide in the Installation and Maintenance Manual
					Water flow too low or air in the system	Re-establish nominal water flow or bleed the system
AL12	Low pressure lockout	Complete thermodynamic function stoppage (no manual reset).	Manual (PAC HT OFF via keypad) after at least 2 minutes stoppage	60 s after compressor start-up	Refer to the fault diagnosis guide in the Installation and Maintenance Manual	Refer to the fault diagnosis guide in the Installation and Maintenance Manual
					Coil blocked	Clean the finned coil
					incomplete de-icing (lack of refrigerant charge)	Check the amount of refrigerant charge
AL13	Internal clock of the controller faulty.	Information	Manual	None	Defective internal regulator clock.	Confirm the problem by switching the mains power on several times. Replace the Indoor unit regulator.
AL14	Both compressor alarm, unit stopped	Complete thermodynamic function stoppage	Manual (PAC HT OFF via keypad)	None	Both compressors in Alarm mode	Find the cause of the alarm for each compressor

Ref.	Alarm description	PAC HT action	Alarm cancellation	Time delay	Possible cause(s)	Recommended action(s)
AL16	Comm. loss PAC HT / room terminal, heating forced.	Switchover to forced Heating mode by changing the adjustable ambient temperature (Default setting: 20° C)	Manual	Variable depending on the cause of the problem (clean trip or trip due to electrical interference)	Ambiance terminal is not connected	Deactivate it via the PAC HT keypad
					One of the communication cables is disconnected	Check the connections on the PAC HT and the terminal as well as the polarities (A and B)
					Too much interference on the communication bus	Use shielded cable as recommended
AL17	Phase inversion or one phase missing	Complete shutdown	Manual	None	Power supply fault detection by the phase controller (three phase)	Two phases have been inverted or one phase is missing. Refer to the Installation and Maintenance Manual
AL18	Deicing required, compressor 1 / big not available	Complete shutdown	Auto. If outdoor conditions permit natural de-icing	None	There is a fault on the large C1 compressor at a time when it is required by the PAC HT for de-icing	Rectify the fault on the C1 compressor
AL20	Deicing by evaporating pressure < 0.6bar	De-icing	Automatic after 30 min. compressor operation. D	Variable	Outdoor temperature or De-icing probe defective but undetected.	Check the values recorded by the Outdoor and De-icing temperature probes. Replace the probe if necessary.
					Evaporation pressure sensor defective but undetected.	Check the evaporation pressure value in operation. Replace the sensor if necessary.
					Outdoor temperature too low for PAC HT operation.	
AL21	2 deicings by evaporating pressure < 0.6bar in 30 minutes	Thermodynamic function stopped completely.			Refrigerant leak.	Checked for leaks. Check the refrigerant charge.
					Ineffective de-icing, exchanger blocked.	Clean the fin exchanger.
					Outdoor temperature too low for PAC HT operation.	
AL22	Deicing ended abnormally by maximum duration	De-icing stopped	Auto. Alarm displayed for 10 minutes for information purposes	None	De-icing has lasted over 10 minutes. This is abnormal as de-icing usually takes between 3 and 4 minutes	Monitor the appliance to see if this fault is a one-off occurrence, if not, check all possible causes of poor de-icing (lack of refrigerant charge)
AL23	Deicing ended abnormally by leaving water temp. < 10°C	De-icing stopped	Auto. Alarm displayed for 10 minutes for information purposes	None	Outlet water temperature during de-icing has fallen below 10° C	Check that there is sufficient water volume in the system, as recommended in the Installation and Maintenance Manual
AL25	Discharge temperature too high	Thermodynamic function stopped completely.	Manual	None	Cut out by the N°2 compressor outlet temperature probe	Monitor to determine whether this fault is a one-off incident. If not, check the overheating value on the display (may be too high in the event of outflow being cut off).
AL27	Deicing valve failure	Thermodynamic function stopped completely.	Manual (PAC HT OFF via keypad)	90 s	De-icing valve fault detected automatically by the control system. Valve disconnected, inverted or blocked	Check valve wiring. Activate the Manual controller outputs and check that the valve operates. Replace the valve if the slide is blocked or the coil is burnt out
AL28	Compressor 1 alarm by controller, 2 successive AL34	Automatic changeover to C2 compressor WARNING: De-icing impossible.	Manual (PAC HT OFF via keypad)	90 s	Fault detected automatically by the system management (e.g. when the Temp. difference is too low, indicating that the compressor has not started)	Refer to fault diagnosis guide in the Installation and Maintenance Manual Probable cause: Faulty single phase soft starter, compressor protection fuse melted, excessively low supply voltage or phase missing on the compressor.
AL29	Compressor 2 alarm by controller, 2 successive AL35	Automatic changeover to C1 compressor	Manual (PAC HT OFF via keypad)	90 s		
AL30	Deicing problem - Compressor 1 or compressor valve	Automatic changeover to C2 compressor	Manual (PAC HT OFF via keypad)	90 s	Zero temperature difference during de-icing due to C1 compressor not starting or non activation of the compressor changeover valve. Impossible to determine the cause of the blockage in compressor C1 with certainty	Check that C1 is operating correctly. Check the compressor changeover valve wiring. Activate the Manual controller outputs and check that the valve operates. Replace the valve if the slide is blocked or the coil is burnt out
AL31	Compressor reversing valve failure	Automatic changeover to C2 compressor	Manual (PAC HT OFF via keypad)	10 s	Alarm generated by the intermediate pressostat. Compressor changeover valve disconnected, blocked or coil burnt out	Check the compressor changeover valve wiring. Activate the Manual controller outputs and check that the valve operates. Replace the valve if the slide is blocked or the coil is burnt out

Ref.	Alarm description	PAC HT action	Alarm cancellation	Time delay	Possible cause(s)	Recommended action(s)
AL32	Entering/leaving water sensors reversed	Complete shutdown	Manual (PAC HT OFF via keypad)	90 s	Auto detection by checking whether the water temperature probes are inverted.	Invert the probes at the level of the regulator. Check the probe values when the compressor(s)is/are running.
AL33	DT > 20°C, low water flow	Complete thermodynamic function stoppage	Manual (PAC HT OFF via keypad)	90 s	Insufficient water flow in the circuit, flow too low for proper PAC HT operation	Check that the water flow in the system is always adequate (presence of thermostatic radiator valves) Clean the inlet water filter on the PAC HT
AL34	Compressor 1 alarm by controller (water DT < 1°C)	Complete shutdown during 7 minutes. 2 cut-outs ➡ AL28	Automatic	90 s	Fault detected automatically by the system management (e.g. when the Temp. difference is too low, indicating that the compressor has not started)	Refer to fault diagnosis guide in the Installation and Maintenance Manual Probable cause: Faulty single phase soft starter, compressor protection fuse melted, excessively low supply voltage or phase missing on the compressor
AL35	Compressor 2 alarm by controller (water DT < 1°C)	Complete shutdown during 7 minutes. 2 cut-outs ➡ AL29	Automatic	90 s		
INF36	--Information-- Back-up heater Boiler/Electric heater enabled	Information	Stop backup mode	None	Activation of the EMH digital input of the controller or backup mode through the display for boiler relief	
AL39	Water pressure < 0.5bar in the heating circuit	Information	Pressure > 1 bar for 5s.	10 s	Insufficient water pressure in the Heating circuit.	Add water to the heating circuit. Check proper expansion tank operation. Check for leaks on the Heating network.
AL40	No communication with the outdoor unit	Complete thermodynamic function stoppage	Manual and Com OK for 22s.	22s	Incorrect wiring.	Check bus connections at both ends.
					Communication bus cable cut.	Check the condition of the bus cable
					Unshielded cable.	Install shielded cable.
					Outdoor unit not auto-detected.	Check the wiring of the Outdoor unit probes.
AL41	1 PAC HT unit not recognized on the communication bus	Information	Automatic	None	Probes B1 to B4, B8 and B9 partially or totally disconnected on the unit in question.	Check the probe values on the display and check the probe connections.
AL42	Indoor/outdoor units software versions incompatible	Complete thermodynamic function stoppage	Power supply cut.	None	Different versions for Indoor and Outdoor units.	Update the programme for both units.
AL43	No PAC HT model detected Split or Monobloc	Complete stoppage.	Power supply cut.	None	Probes B1 to B4, B8 and B9 partially or totally disconnected on the unit in question.	Check the probe values on the display and check the probe connections.
AL44	PAC HT model modified for the indoor unit	Information		None	Probes B1 to B4, B8 and B9 partially or totally disconnected on the unit in question => incorrect model detection	Check the probe values on the display and check the probe connections.
					µPC replaced by that of another PAC HT (Split Indoor/Outdoor /Monobloc)	Confirm once the situation is understood.
					Programme taken from another PAC HT (Split Indoor/Outdoor/Monobloc)	
AL45	PAC HT model modified for the outdoor unit	Information		None	Probes B1 to B4, B8 and B9 partially or totally disconnected on the unit in question => incorrect model detection	Check the probe values on the display and check the probe connections.
					µPC replaced by that of another PAC HT (Split Indoor/Outdoor /Monobloc)	Confirm once the situation is understood.
					Programme taken from another PAC HT (Split Indoor/Outdoor/Monobloc).	
AL46	Size modified for the outdoor unit	Information		None	Modification of the wiring of the analogue inputs B5 and B12 of the Outdoor unit configuration.	Check the status and the wiring of B5 and B12
					Programme or µPC replaced by another Outdoor unit.	Confirm once the situation is understood.

Ref.	Alarm description	PAC HT action	Alarm cancellation	Time delay	Possible cause(s)	Recommended action(s)
AL47	Different indoor and outdoor unit sizes	Information		None	Different Indoor and Outdoor unit sizes.	Check the sizes and their correspondence on the makers plates. Check the status and the wiring of inputs B5 and B12 on the Outdoor unit.
AL48	Water flow meter disconnected or damaged	Complete stoppage.	Manual	10 s	Flow meter disconnected or faulty.	Check the wiring of the flow meter, replace the flow meter if it is faulty.
					Faulty 0-5V supply.	Measure the 0-5V voltage.
AL49	Water pressure sensor disconnected or damaged	Information	Manual	10 ss	Water pressure sensor disconnected or damaged.	Check the sensor wiring, replace the sensor if it is faulty.
					Faulty 0-5V supply.	Measure the 0-5V voltage.
AL50	Compressor discharge sensor disconnected or damaged	Complete thermodynamic function stoppage	Manual	10 s	Probe disconnected or damaged.	Check the probe wiring, replace the probe if it is faulty.
AL51	Evaporating temperature sensor disconnected or damaged	Complete thermodynamic function stoppage	Manual	10 s	Probe disconnected or damaged.	Check the probe wiring, replace the probe if it is faulty.
AL52	Evaporating pressure sensor disconnected or damaged	Complete thermodynamic function stoppage	Manual	10 s	Transducer disconnected or damaged.	Check the transducer wiring, replace the transducer if it is faulty.
INF56	Software updated or new controller in the indoor unit	Information	Manual	None	Programme update or µPC replaced in the Indoor unit.	Confirm once the situation is understood.
INF57	Software updated or new controller in the outdoor unit	Information	Manual	None	Programme update or µPC replaced in the Outdoor unit.	Confirm once the situation is understood.
INF58	No indoor unit size in controller memory	Information	Manual	None	Programme update or µPC replaced in the Indoor unit.	Check the size of the Indoor unit on the makers plate. Key in the details and then confirm
AL59	Swimming pool sensor disconnected or damaged	Swimming pool function stopped.	Manual	10 s	Probe disconnected or damaged.	Check the probe wiring, replace the probe if it is faulty.
AL76	PAC HT stopped by outdoor temperature too high	Complete thermodynamic function stoppage	Automatic	None	Outdoor temperature too high (>40°C) for Heating or DHW operation.	Wait until the outdoor temperature drops (restart value visible on the alarm screen).

GENERAL COMMENTS:

If you have a doubt about a **PAC HT** component, use the Manual activation function for the outputs (all the all or nothing outputs excluding the compressors) via the "INSTALLATION" menu on the appliances display. Use a volt-meter to check that the regulator output is activated (230V) and that the component is question is also activated. The **PAC HT** retains a very comprehensive log of alarms, i.e. the 150 last alarms, as well as temperature probe values (water inlet and outlet, outdoor and outdoor battery) when the alarm appears. You can access this log from the main menu (sub-menu "Alarm log").

Press the ENTER () key to switch back and forth between the log screen and the probes screen.

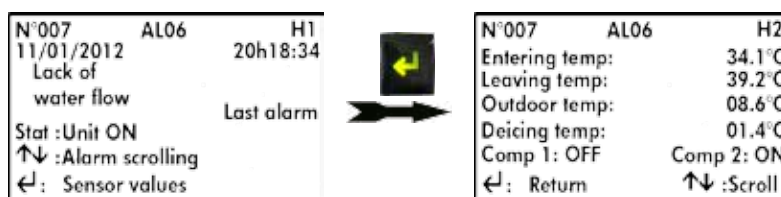

 **Generally, an alarm means that there is an anomaly with the appliance. We strongly advise against repeatedly resetting an alarm at the risk of causing irreparable damage to one or several components.**

[FAULTY DIAGNOSIS GUIDE]

Simple diagnosis advice. In the event of a breakdown, you should contact your local after sales department for confirmation and assistance.

Compressor does not start		
Problem symptoms	Probable cause	Recommended action
Power is present at the compressor terminal but the motor does not rotate	Motor burnt out	Replace the compressor
Motor contactor inoperable	Coil burnt out or contacts broken	Repair or replace the contactor
No current upstream of the motor contactor	Circuit breaker tripped	Check the fuses / thermo-magnetic circuit breakers and electrical connections
Current upstream of the fuse, but not on the contactor side	Fuse blown or thermo-magnetic circuit breaker tripped	Replace the fuse. Reset the thermo-magnetic circuit breaker Check current values
Low voltage measured on voltmeter	Voltage too low	Contact your electricity supplier
No power supply to contactor coil	Regulation open circuit	Use the appliance display to check that the system is actually calling for compressor operation
Compressor operates but current draw is abnormally high	Compressor damaged	Replace the compressor
"Growling" compressor motor	Excessive output pressure Abnormally low voltage on start-up in single phase	Check the supply voltage. Refer to the single phase soft start faults chart Check the controller control relays and their wiring (refer to wiring diagrams)

Compressor stops		
Problem symptoms	Probable cause	Recommended action
HP pressostat triggered	Excessively high outlet pressure	Refer to instructions provided for "high outlet pressure"
Discharge thermostat triggered	Lack of refrigerant fluid	Repair the leak. Add refrigerant fluid or completely replace the charge
	Abnormal Compressor superheat	Set the superheat on the expansion valve
	Defective de-icing	Check proper de-icing operation
Inlet pressure too low	Dryer filter blocked	Replace dryer filter
	Lack of refrigerant fluid	Repair the leak. Add refrigerant fluid or completely replace the charge
	Faulty expansion valve	Replace the expansion valve
Dryer filter iced up	Abnormal icing up of finned exchanger	Check proper operation of de-icing function
	Blocked dryer filter	Replace the dryer filter

Compressor lubrication problem		
Problem symptoms	Probable cause	Recommended action
Noisy compressor	Fault in oil equalisation system	Check operation of the oil equalisation valve. Contact your After Sales Service

Excessively high discharge pressure		
Problem symptoms	Probable cause	Recommended action
Major difference between condensing and water outlet temperatures	Presence of incondensable matter in the system or excessive refrigerant fluid charge Presence of air in water circuit	Bleed the incondensable matter and drain off the excess refrigerant fluid Bleed the air from the circuit
High output pressure and very high water ΔT	Insufficient water flow	Flow meter control Ensure that there is an adequate water flow through the entire system

Excessively high inlet pressure		
Problem symptoms	Probable cause	Recommended action
Presence of liquid in the intake line	Expansion valve open too far	Check the overheating value on the display. Check the position of the pressure sensor and the evaporation temperature probe. Check the values present on the display.
Refrigerant fluid flow back towards the compressor, irrespective of the expansion valve setting	Expansion valve blocked in open position	Inspect the electronic regulator wiring on the Outdoor unit regulator. Replace the regulator if it does not react when mains power is switched on to the unit.

Excessively low inlet pressure		
Problems - symptoms	Probable cause	Recommended action
Excessive pressure loss across the dryer filter	Clogged dryer filter	Replace the dryer filter
Refrigerant does not pass through the electronic pressure relief valve, irrespective of the regulator settings.	The electronic pressure relief valve is faulty.	Replace the electronic pressure relief valve.
	The electronic pressure relief valve is disconnected from the Outdoor unit's regulator	Reconnect the electronic pressure relief valve wiring.
Loss of power	Expansion valve blocked	Replace the expansion valve
	Lack of refrigerant fluid	Repair the leak. Add refrigerant fluid or completely replace the charge
	Evaporator blocked	Clean the finned evaporator
	Insufficient air flow	Check proper operation of the fan/motor units
	Defective de-icing	Check proper operation of de-icing function

Airwell

■ *Just feel well*

Appendix



[DIMENSIONS]

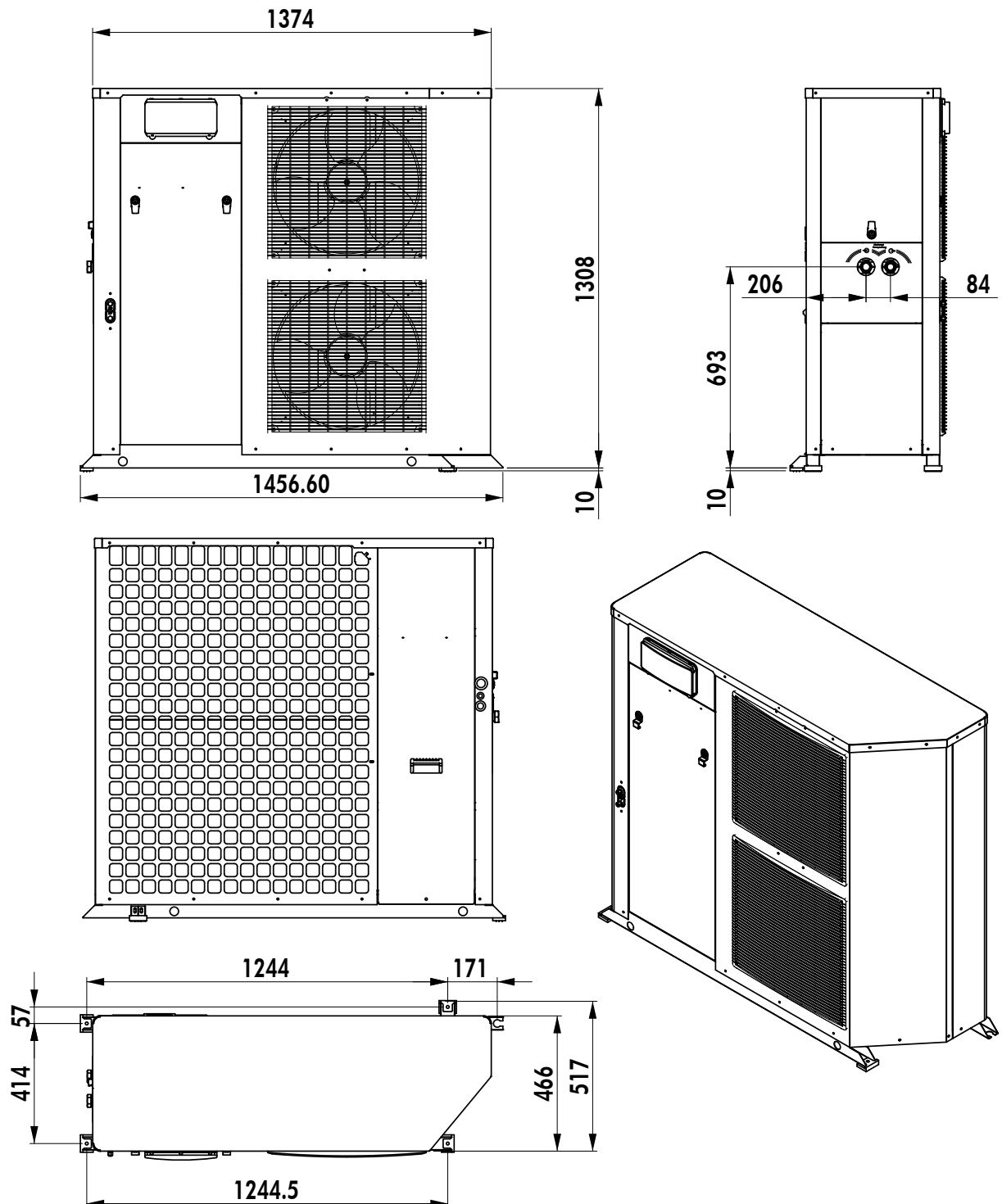

[REFRIGERATION AND HYDRAULIC LINKS DIAGRAM]

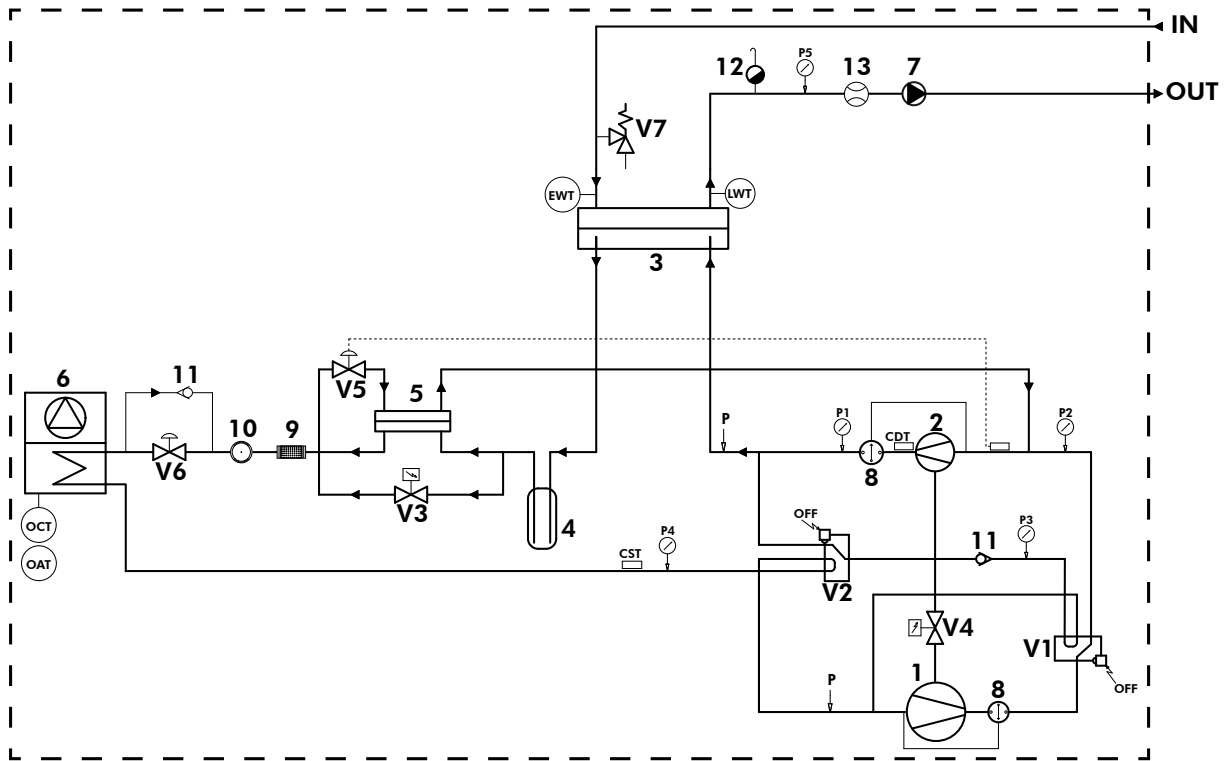

1	Large compressor
2	Small compressor
3	Plate heat exchangers. Counter-current heating
4	Liquid tank
5	Plate heat exchangers. economiser
6	Finned heat exchanger and fans
7	Circulation pump
8	Oil separator
9	Dehydrator filter
10	Liquid warning light
11	Non-return valve
12	Automatic bleed
13	Flowmeter
V1	Four-way valve
V2	Four-way valve
V3	Injection electrovalve

V4	Electrovalve
V5	Injection expansion valve
V6	Electronic expansion valve
V7	Safety valve (3 bar)
P1	High Pressure safety pressostat
P2	High Pressure pressostat
P3	Defrost system high pressure control pressostat
P4	Evaporation pressure probe
P5	Water pressure probe
P	Pressure take-off
CDT	Outlet temperature probe
CST	Evaporation temperature probe
LWT	Water temperature probe (outlet)
EWT	Water temperature probe (inlet)
OCT	Outdoor coil temperature probe
OAT	Outdoor air temperature probe

[WATER FLOW CALCULATION GRAPH]

■ PAC HT 12-6

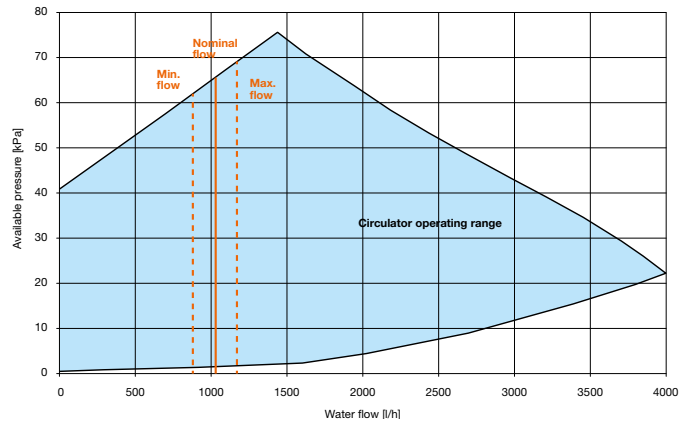

■ PAC HT 14-7

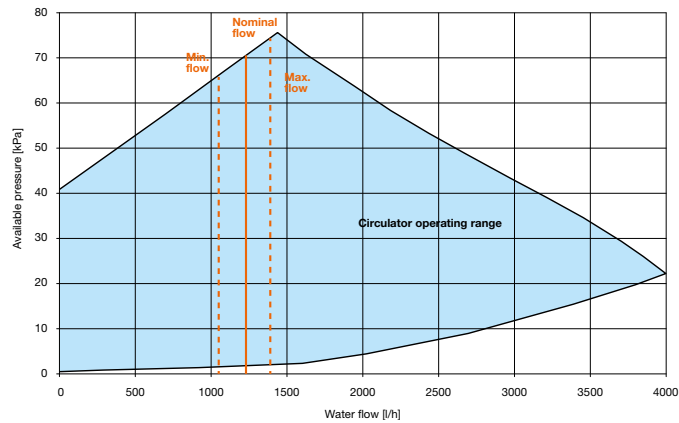

■ PAC HT 18-9

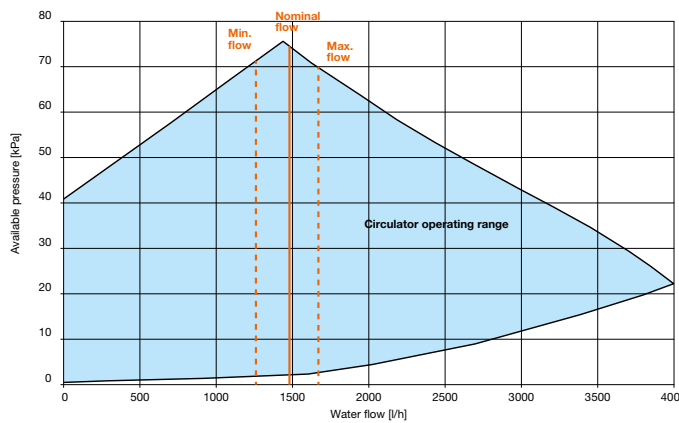

[WIRING DIAGRAM]



TAKE CARE!

These wiring diagrams are correct at the time of publication. Manufacturing changes can lead to modifications. Always refer to the diagram supplied with the product.



POWER SUPPLY MUST BE SWITCHED OFF BEFORE STARTING TO WORK IN THE ELECTRIC CONTROL BOXES!

PAC HT 12-6 230V +/-10% 50HZ

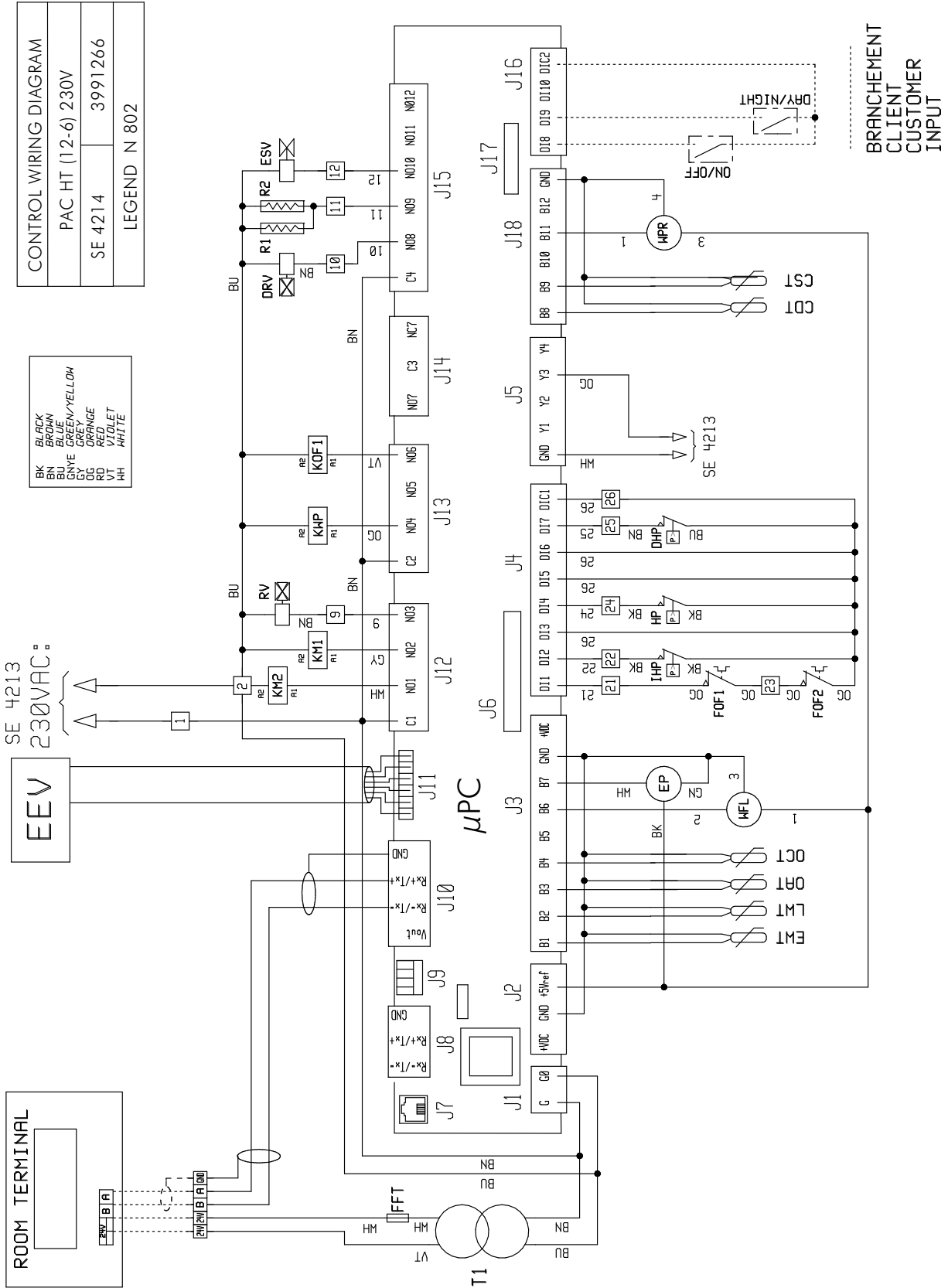

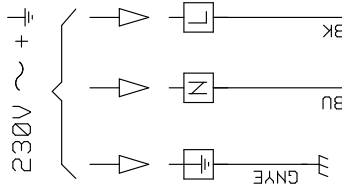

POWER WIRING DIAGRAM	
PAC HT (12-6) 230V	
SE 4213	3991265
LEGEND N 802	

BK	BLACK
BRN	BROWN
BU	BLUE
BLU	BLUE
GNYE	GREEN/YELLOW
GRY	GREY
OG	ORANGE
VT	VIOLET
WH	WHITE

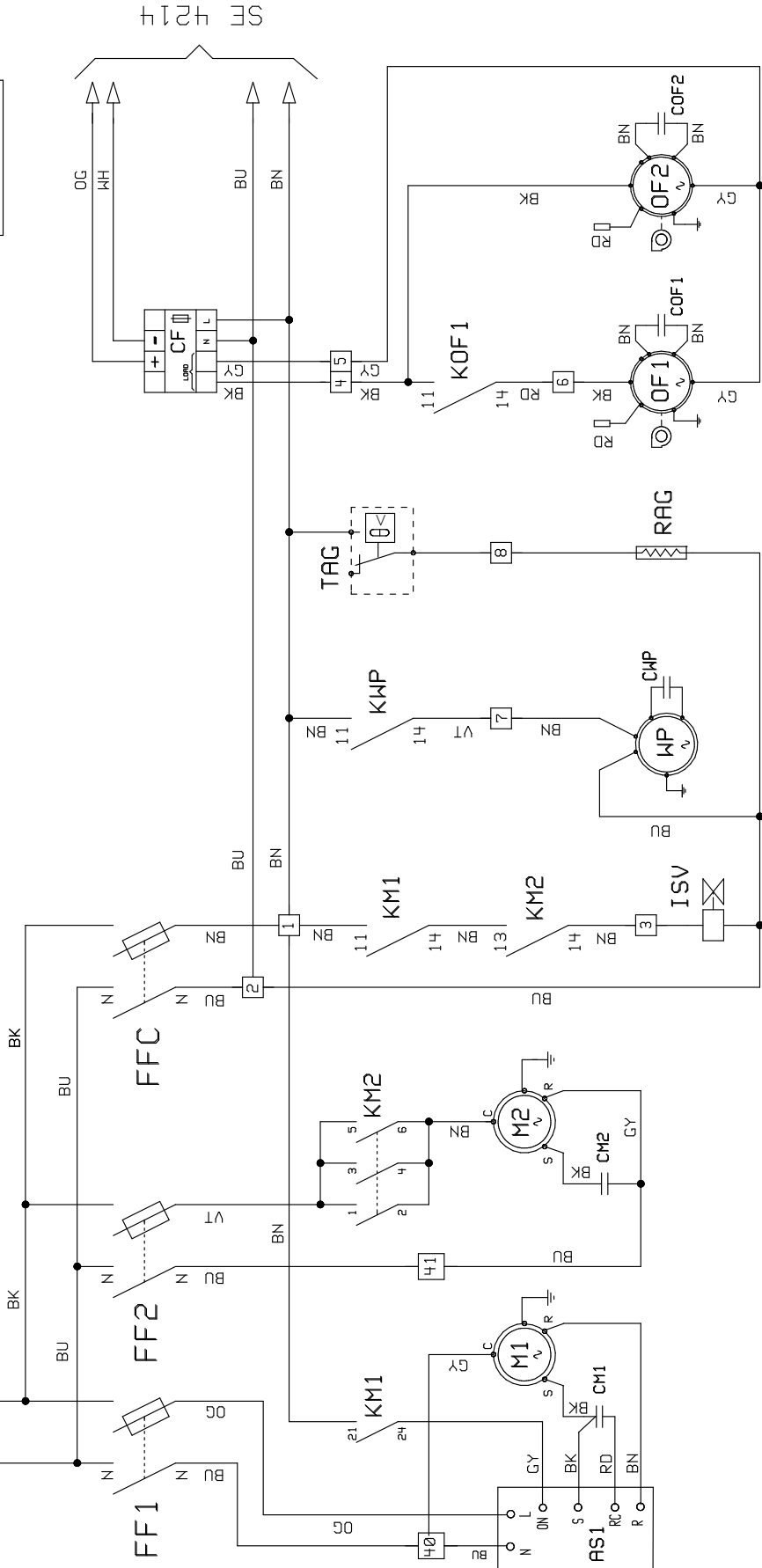

PAC HT 14-7 230V +/-10% 50HZ

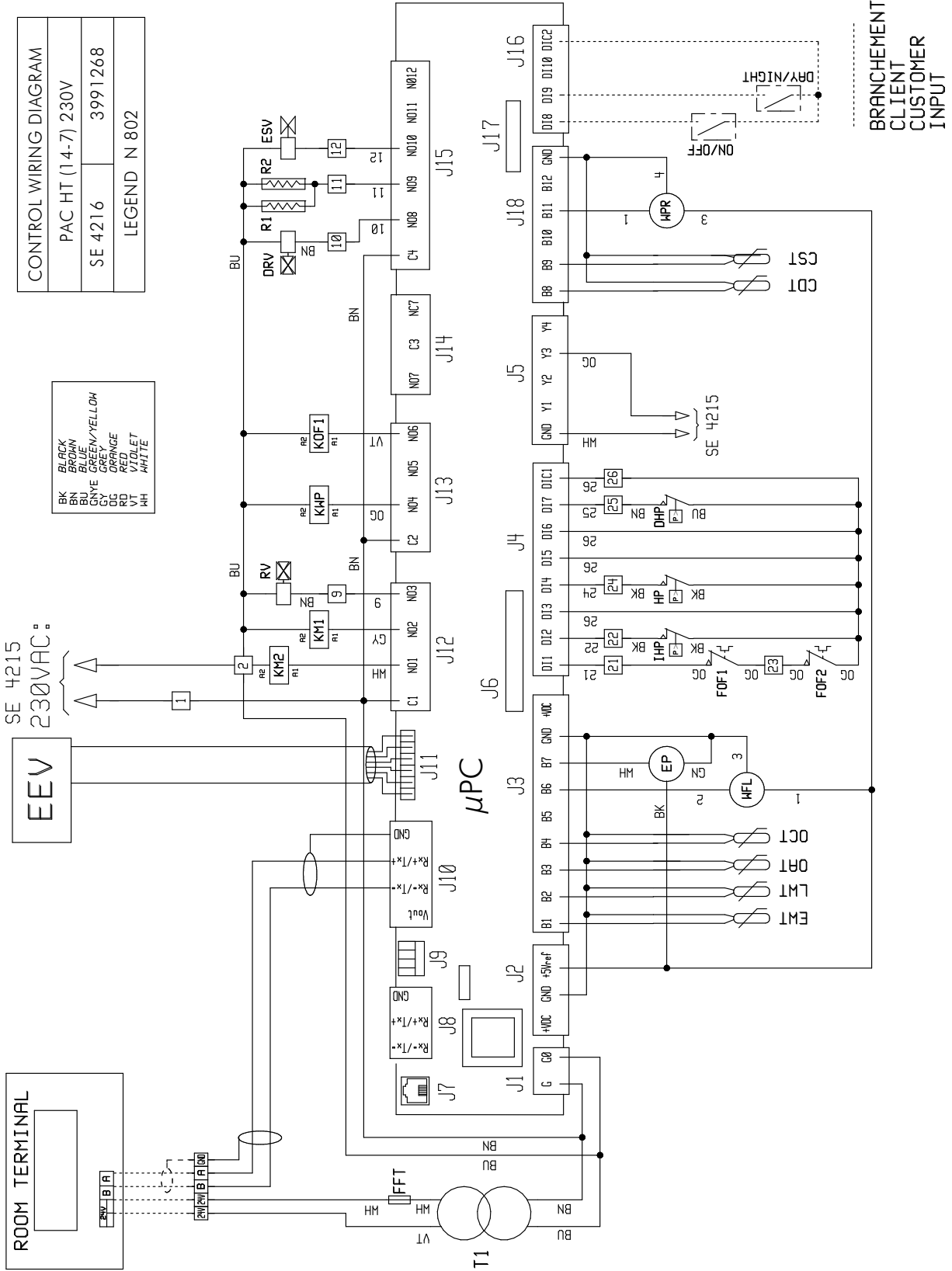

POWER WIRING DIAGRAM	
PAC HT (14-7) 230V	
SE 4215	3991267
LEGEND N 802	

BK	BLACK
BRN	BROWN
BU	BLUE
BLU	BLUE
GNYE	GREEN/YELLOW
GY	GREY
OG	ORANGE
RD	RED
RD	RED
WH	WHITE

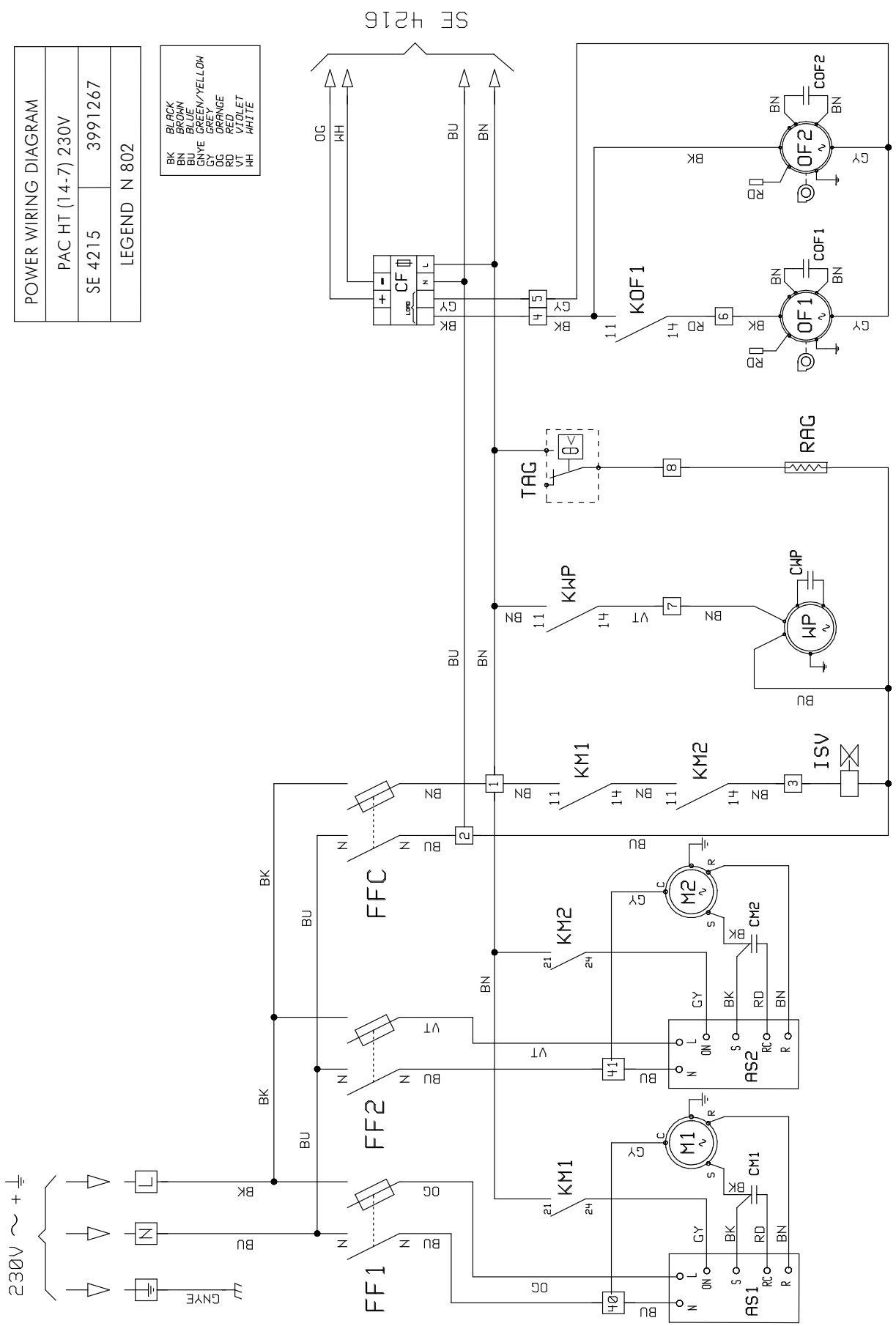

■ PAC HT 12-6 / 14-7 3N~400V +/-10% 50HZ

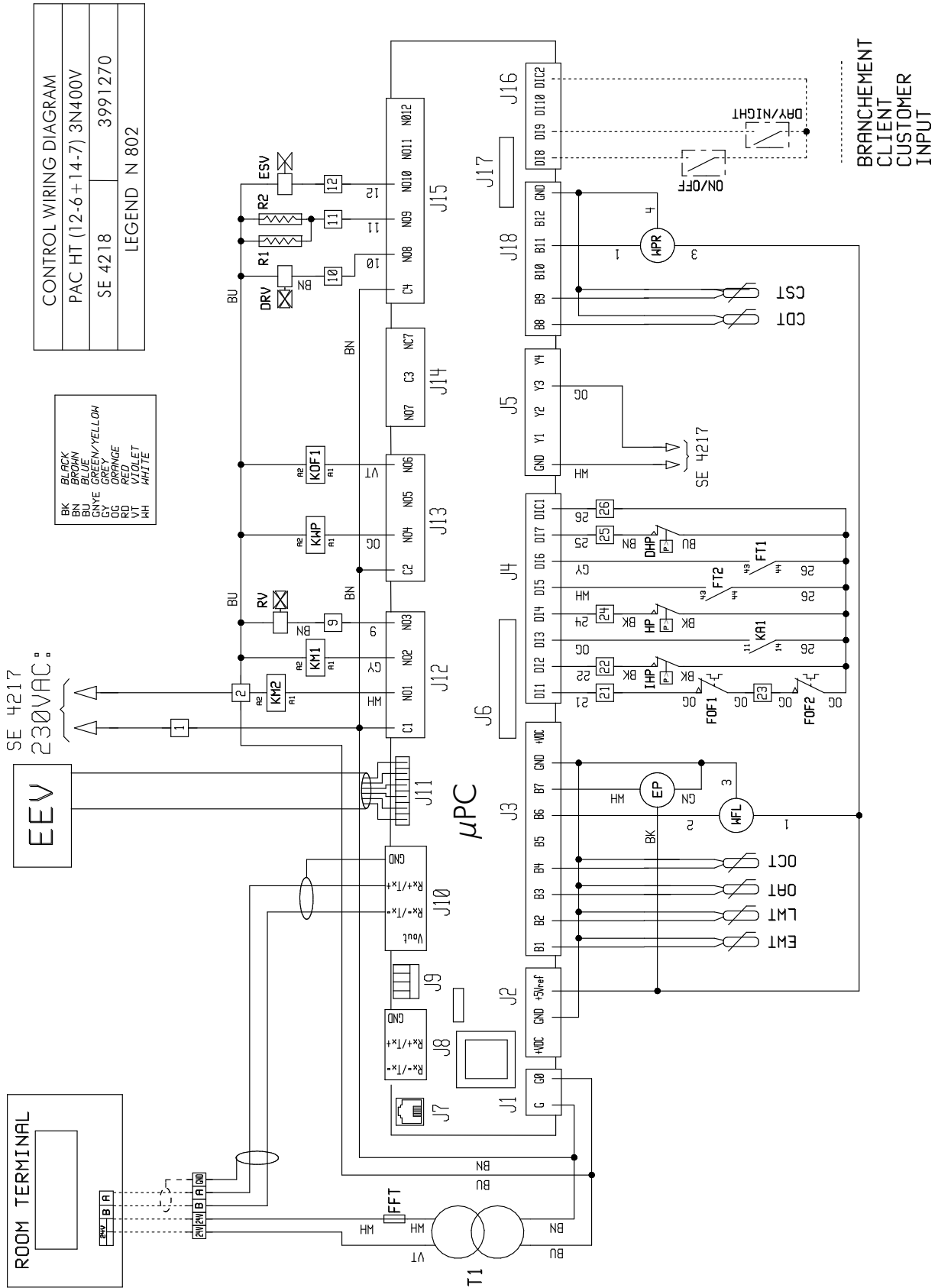

3N400V ~+⊥

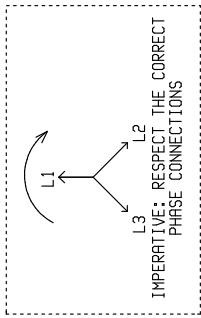
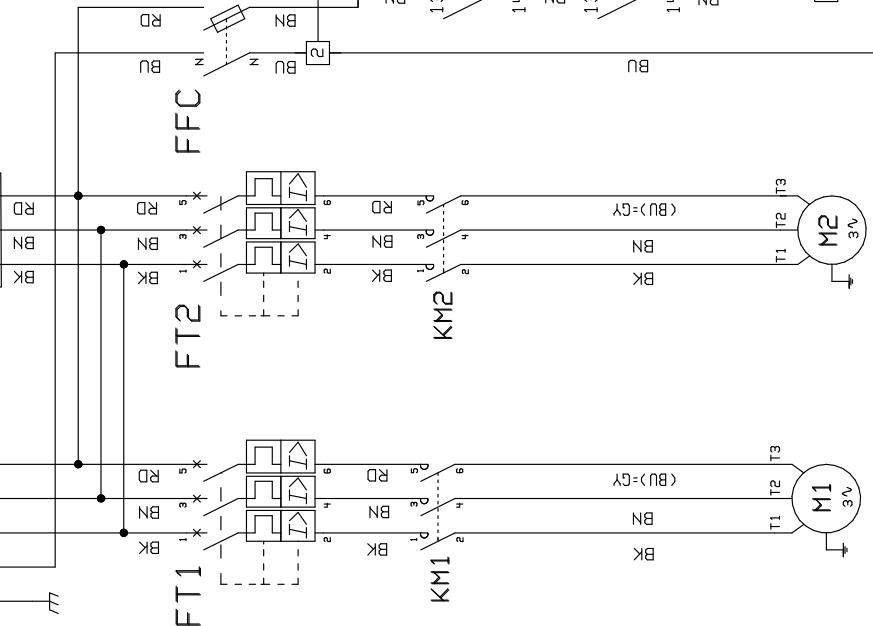
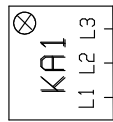
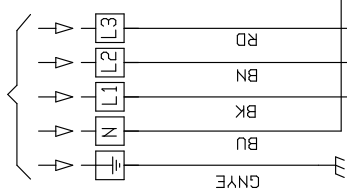

POWER WIRING DIAGRAM	
PAC HT (12-6+14-7) 3N400V	
SE 4217	3991269
LEGEND N 802	

BK	BLACK
BN	BLUE
RD	BROWN
BN	GREEN/YELLOW
GY	GREY
OG	ORANGE
YD	YELLOW
VT	VIOLET
MH	WHITE

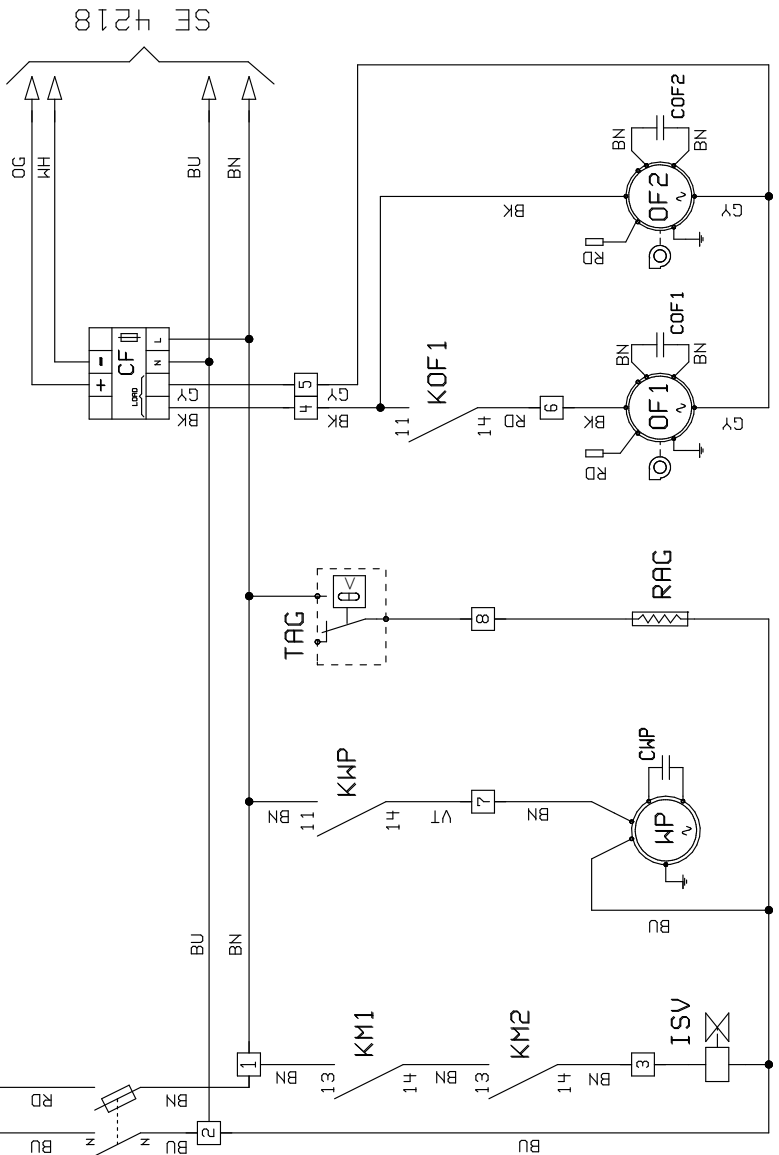

SE 4218

PAC HT 18-9 3N~400V +/-10% 50HZ

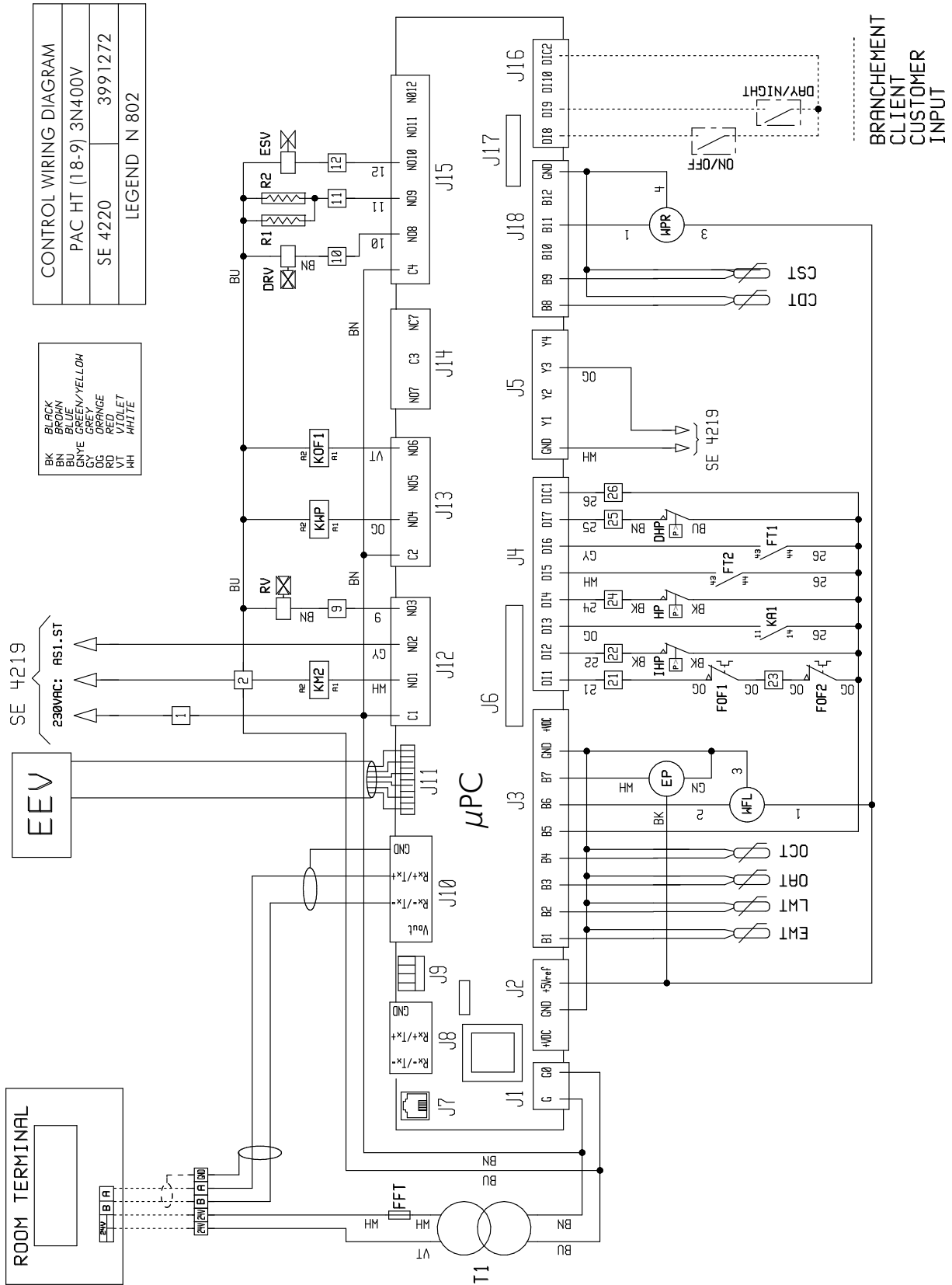

3N400V ~+⊥

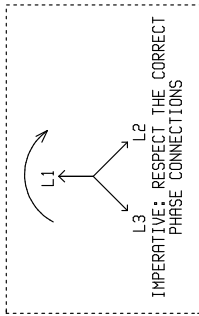
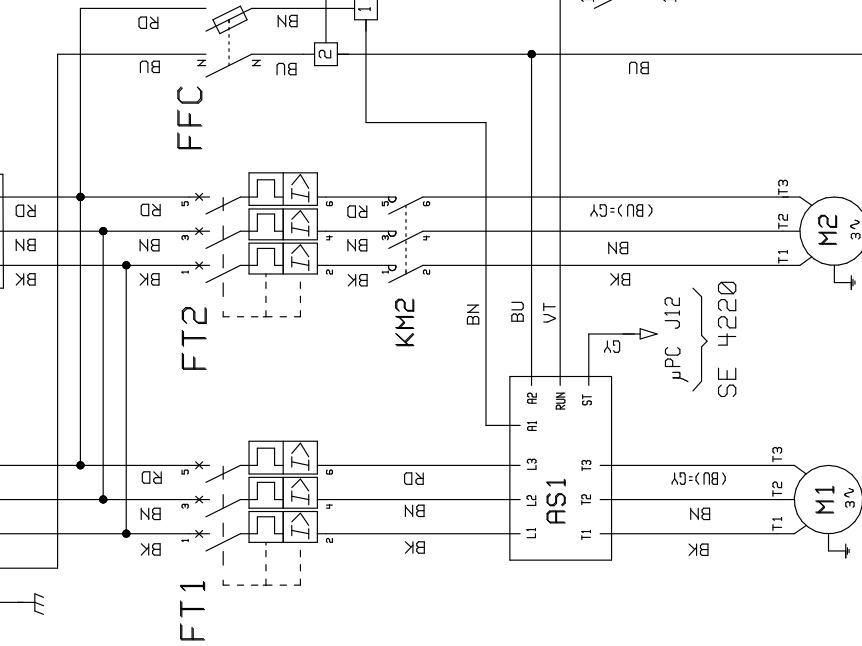
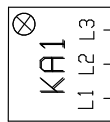
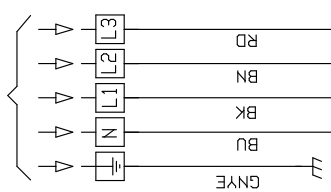

BK	BLACK
BN	BLUE
RD	RED
BN	GREEN/YELLOW
GY	GREY
OG	ORANGE
VT	VIOLET
WH	WHITE

POWER WIRING DIAGRAM	
PAC HT (18-9) 3N400V	
SE 4219	3991271
LEGEND N 802	

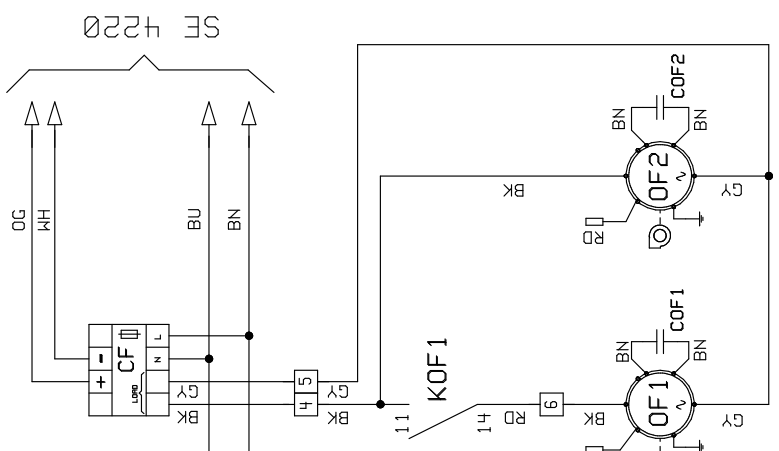

SE 4220

[DOMESTIC HOT WATER PLATE EXCHANGEUR KIT]

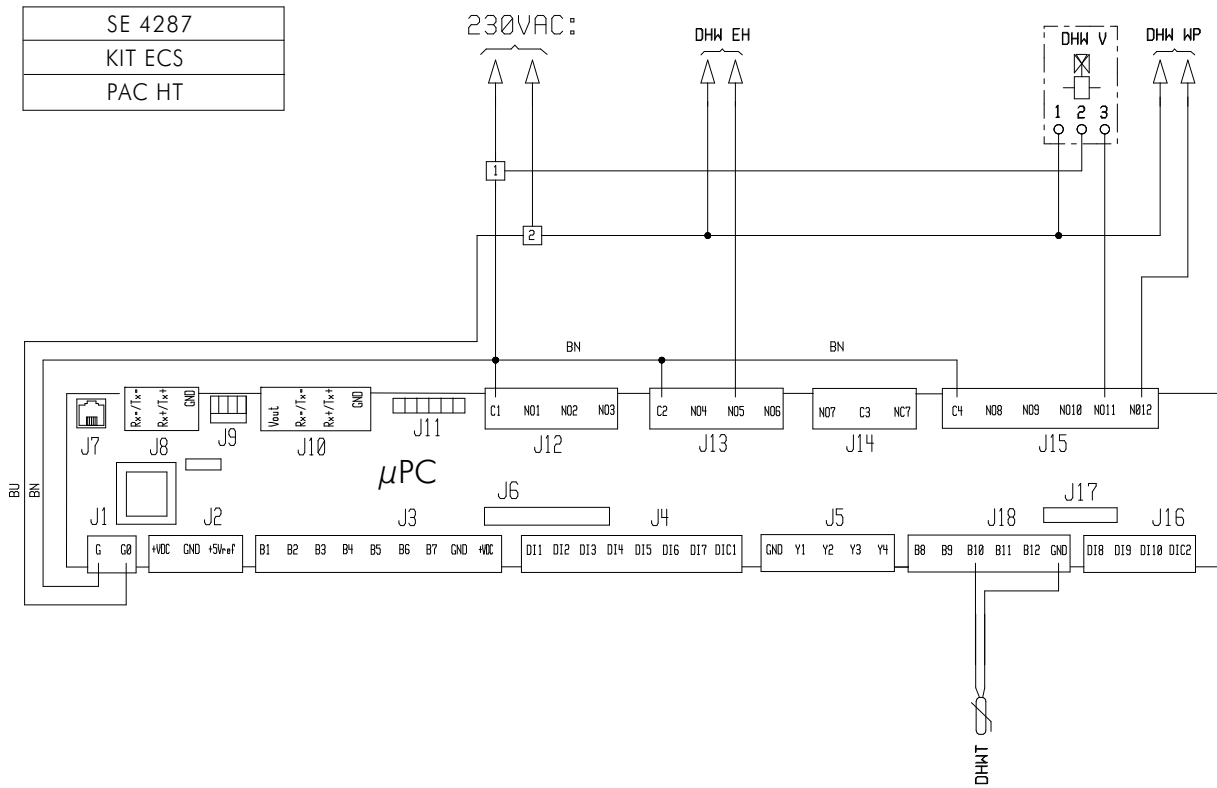

[DUAL ZONE UNDER-FLOOR/RADIATOR HEATING KIT]

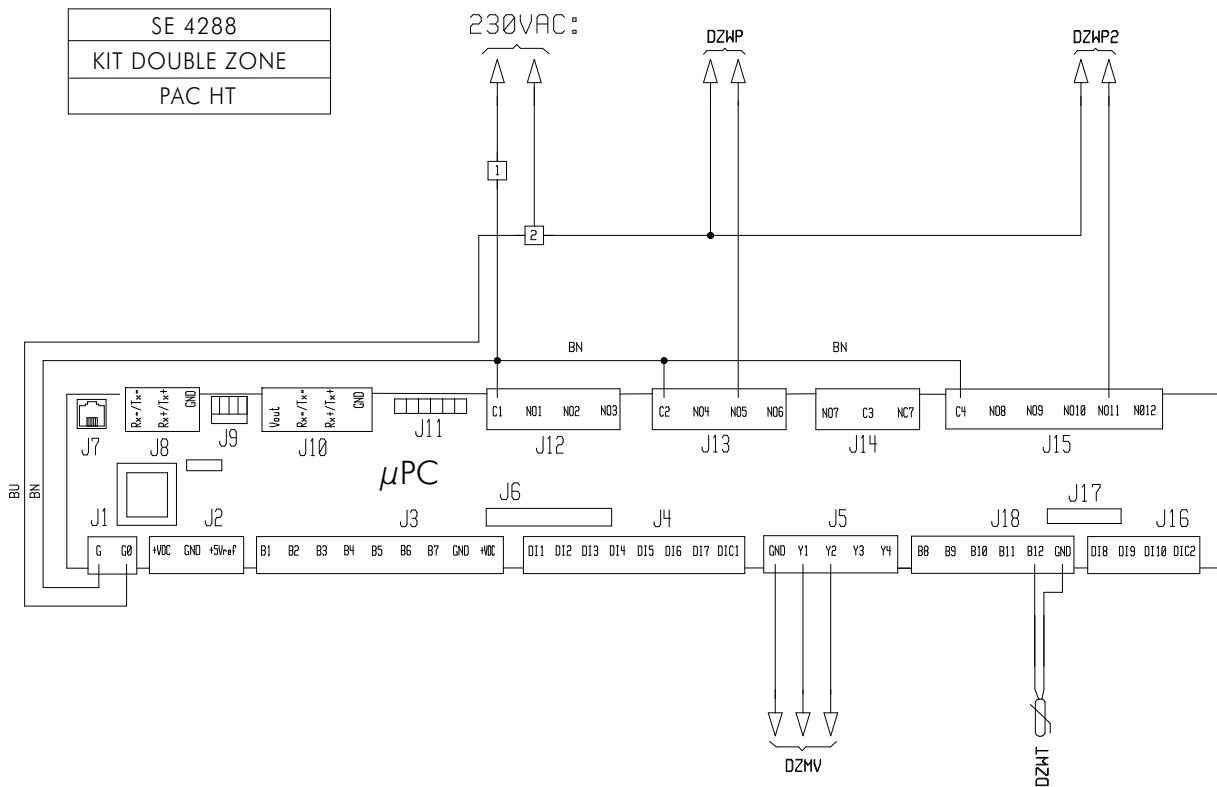

[BOILER RELIEF + DUAL ZONE KIT]

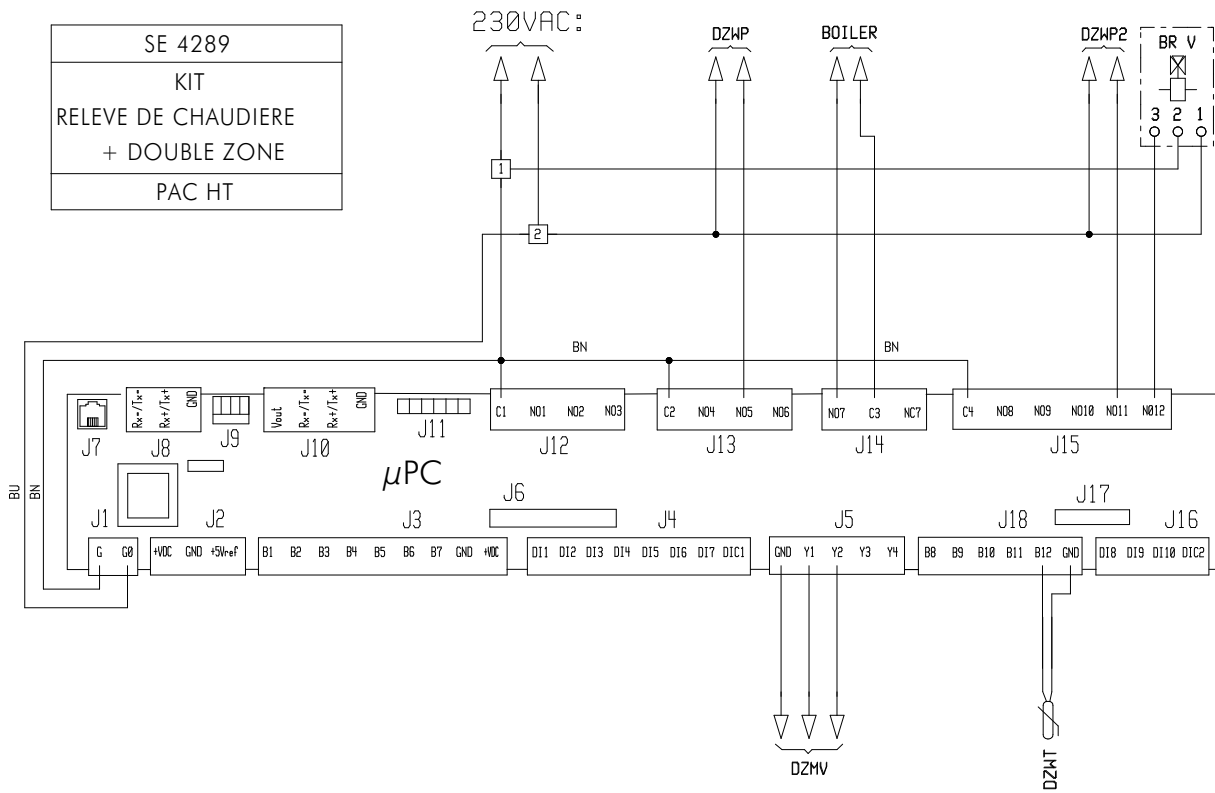

[BOILER RELIEF + DOMESTIC HOT WATER TANK]

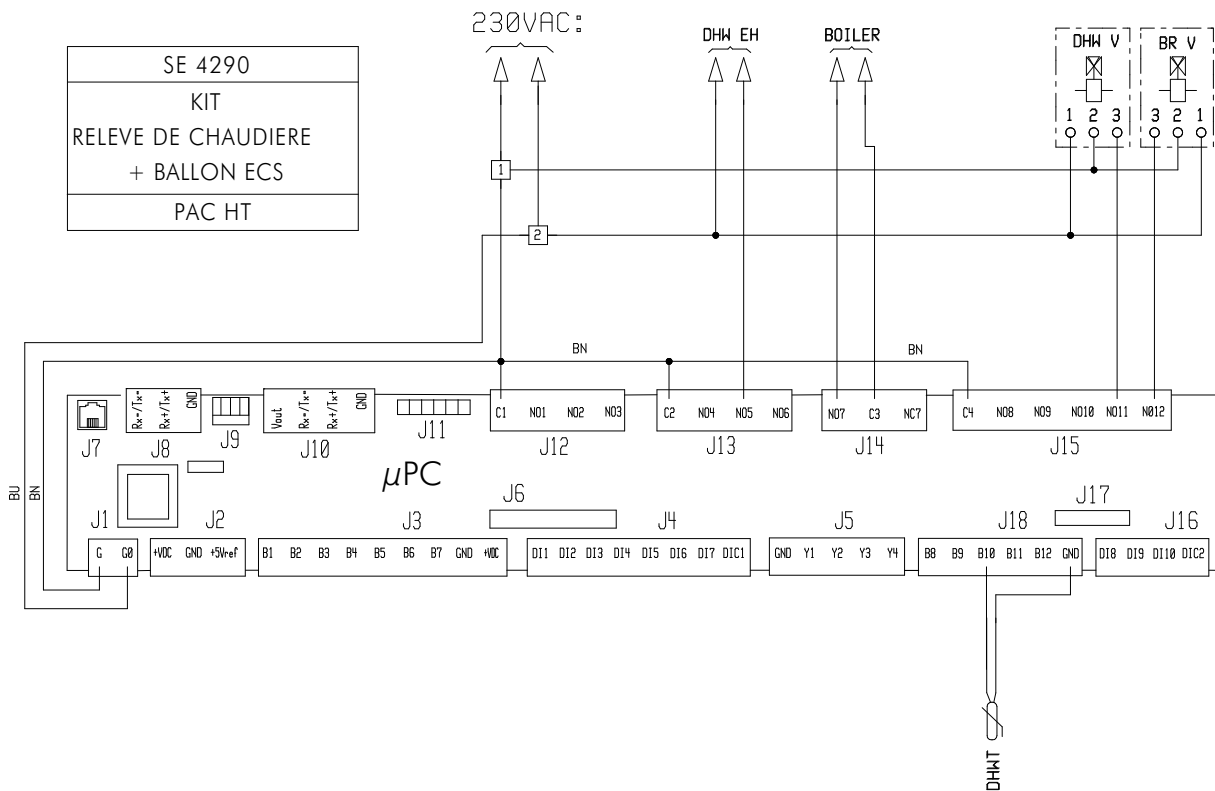

[ELECTRIC HEATER + DOMESTIC HOT WATER TANK]

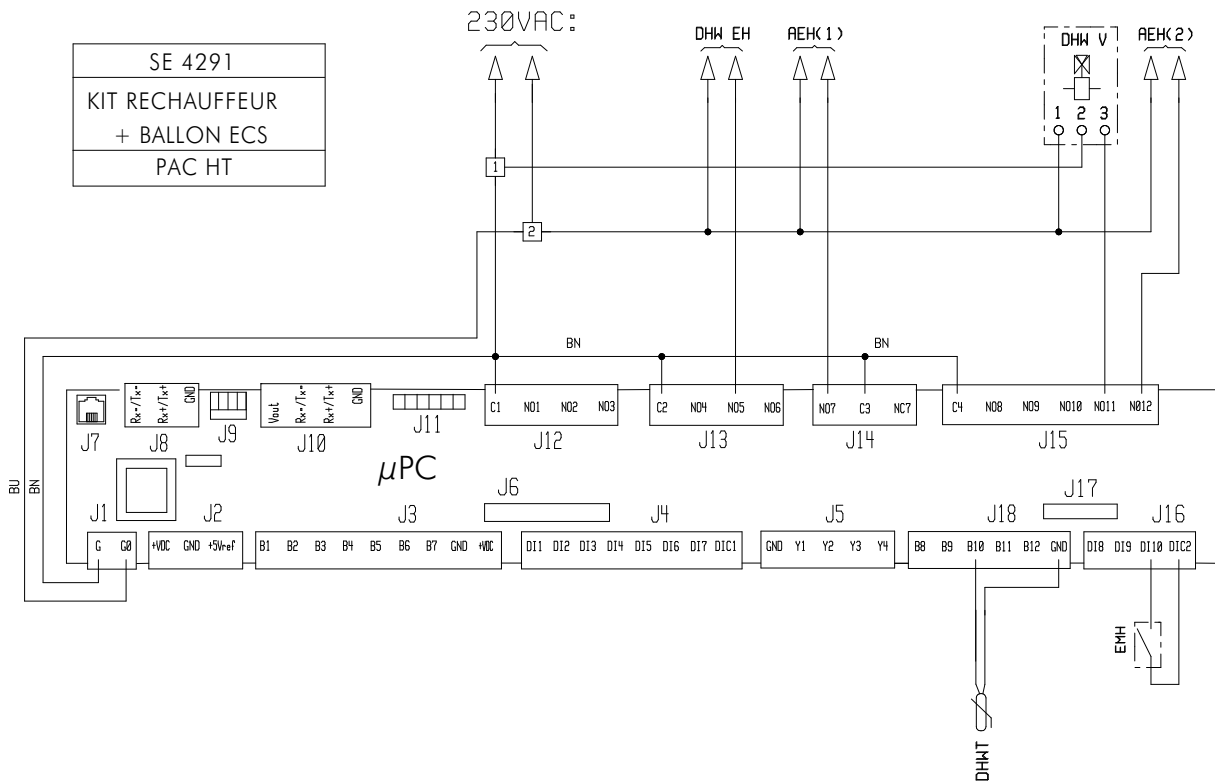

[ELECTRIC HEATER + DUAL ZONE KIT]

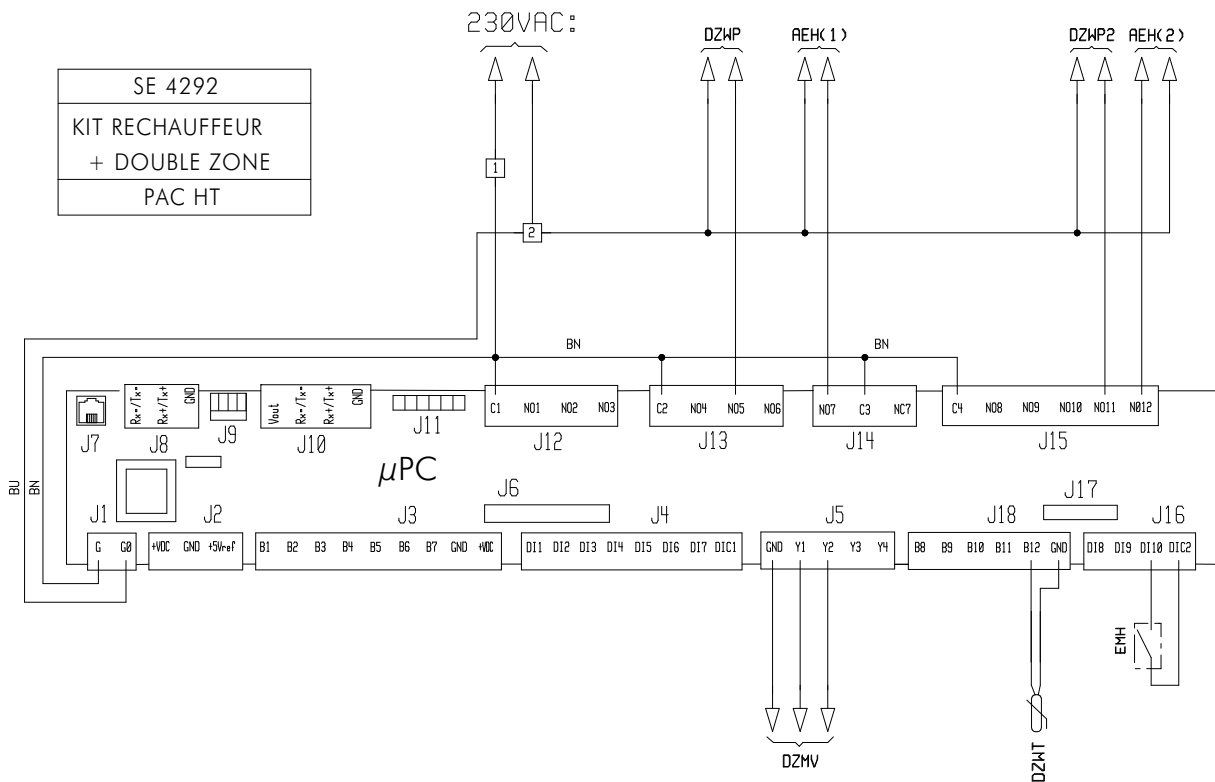

[DOMESTIC HOT WATER TANK + DUAL ZONE KIT]

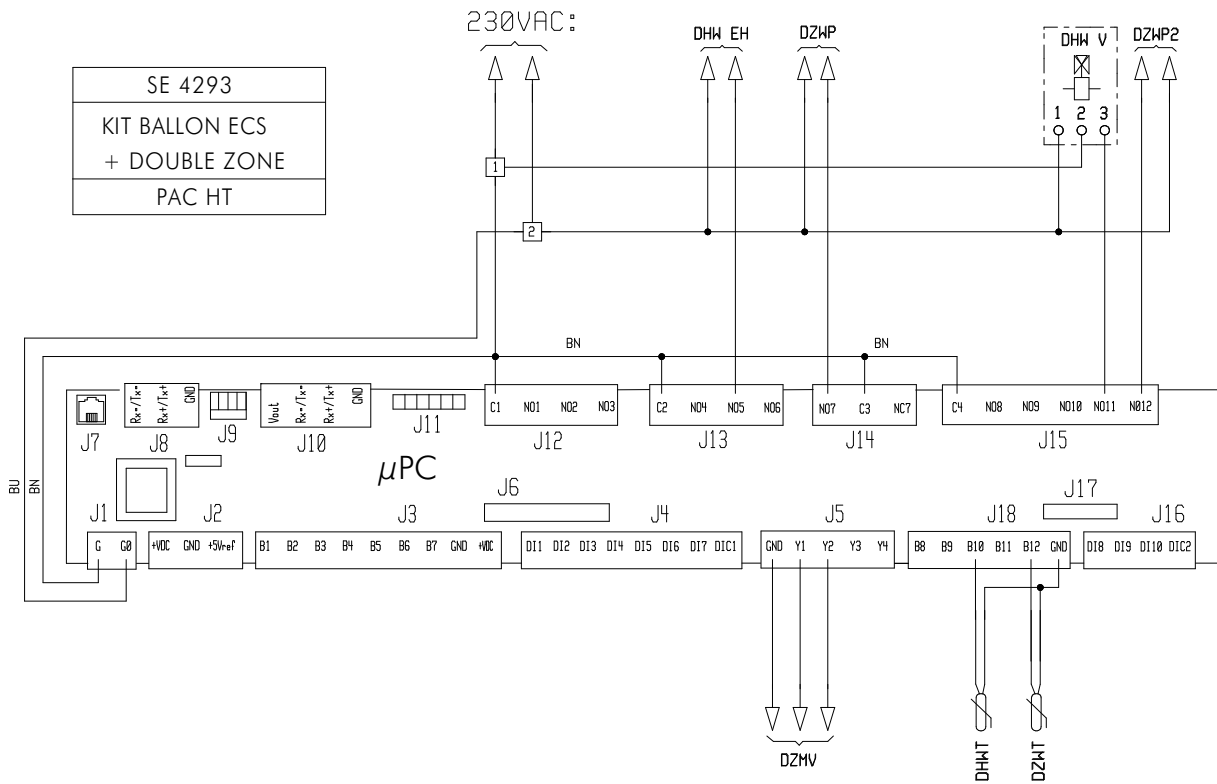

[DOMESTIC HOT WATER TANK]

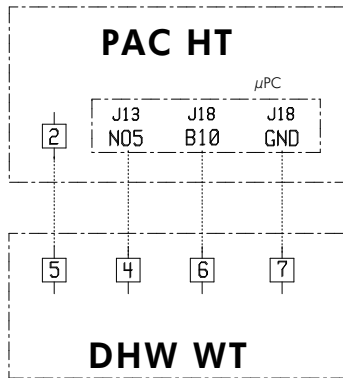

μPC	PAC HT controller
DHW WT	Domestic hot water tank

[ELECTRIC HEATER + DUAL ZONE KIT]

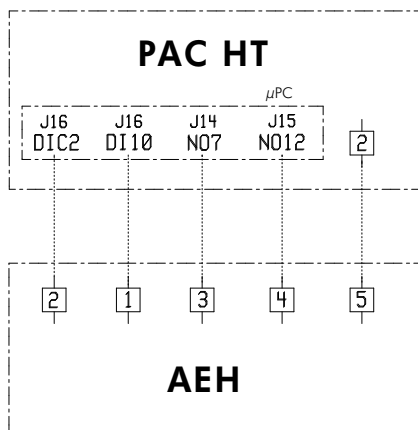

μPC	PAC HT controller
AEH	Additional electric heater

[PERFORMANCES]

■ PAC HT 12-6

		Air 7°C Water 35°C	Air 2°C Water 35°C	Air -7°C Water 35°C	Air -15°C Water 35°C	Air 7°C Water 45°C	Air 7°C Water 55°C	Air -7°C Water 55°C	Air 20°C Water 55°C
Outdoor temperature		2	2	-7	-15	7	7	-7	20
Outlet water temperature		35	35	35	35	45	55	55	55
Water flow	L/h	1 008	1 008	1 008	1 008	960	584	584	584
Heating capacity	W	6 000	8 640	8 960	7 200	5 760	5 520	9 000	7 600
Power input (1)	W	1 459	2 784	2 934	2 796	1 868	2 286	3 681	2 176
COP		4.11	3.10	3.05	2.57	3.08	2.42	2.45	3.49
Compressor		C2	C1+C2	C1+C2	C1+C2	C2	C2	C1+C2	C2

■ PAC HT 14-7

		Air 7°C Water 35°C	Air 2°C Water 35°C	Air -7°C Water 35°C	Air -15°C Water 35°C	Air 7°C Water 45°C	Air 7°C Water 55°C	Air -7°C Water 55°C	Air 20°C Water 55°C
Outdoor temperature		2	2	-7	-15	7	7	-7	20
Outlet water temperature		35	35	35	35	45	55	55	55
Water flow	L/h	1 260	1 260	1 260	1 260	1 200	730	730	730
Heating capacity	W	7 500	10 800	11 200	9 000	7 200	6 900	11 250	9 500
Power input (1)	W	1 820	3 473	3 660	3 488	2 330	2 851	4 592	2 714
COP		4.12	3.11	3.06	2.58	3.09	2.42	2.45	3.50
Compressor		C2	C1+C2	C1+C2	C1+C2	C2	C2	C1+C2	C2

■ PAC HT 18-9

		Air 7°C Water 35°C	Air 2°C Water 35°C	Air -7°C Water 35°C	Air -15°C Water 35°C	Air 7°C Water 45°C	Air 7°C Water 55°C	Air -7°C Water 55°C	Air 20°C Water 55°C
Outdoor temperature		2	2	-7	-15	7	7	-7	20
Outlet water temperature		35	35	35	35	45	55	55	55
Water flow	L/h	1 487	1 487	1 487	1 487	1 416	861	861	861
Heating capacity	W	8 850	10 800	11 200	9 000	7 200	6 900	11 250	9 500
Power input (1)	W	2 085	3 372	3 554	3 387	2 262	2 768	4 458	2 635
COP		4.24	3.20	3.15	2.66	3.18	2.49	2.52	3.61
Compressor		C2	C1+C2	C1+C2	C1+C2	C2	C2	C1+C2	C2

(1) According to EHPA and EN 14511

Airwell

■ *Just feel well*

IOM PAC HT GB 0815 - Specifications subject to change without notice. Pictures non contractual. Printed in UE. BJC