

Airwell

■ *Just feel well*

SIMPLE TECHNICAL MANUAL

YKD 018 [**ECODESIGN**]

Monosplit / DC Inverter



NEW



YKD 018



COMPATIBLE WITH
HKD



[**ECODESIGN**] Comply with ECO Design regulation

[TECHNICAL DATA]

Outdoor unit YKD 018		
Cooling capacity	kW	5.0 (1.4-6.2)
Input power (cooling)	kW	1.66
Heating capacity	kW	5.1 (1.4-6.4)
Input power (heating)	kW	1.41
Circuit breaker rating	A	16
Sound pressure level outdoor unit	dB(A)	55
Weight outdoor unit	kg	35
Refrigerant charge	kg (5m)	1.25
Additional charge	g/m	15
Annual energy consumption (cooling)	kW/h	269
Annual energy consumption (heating)	kW/h	1768
Max length	m	20
Max height	m	8
Refrigerant control	type	Capillary tube

[COMPRESSOR CHECKING]

→ Measure the resistance value of each winding by using the tester.

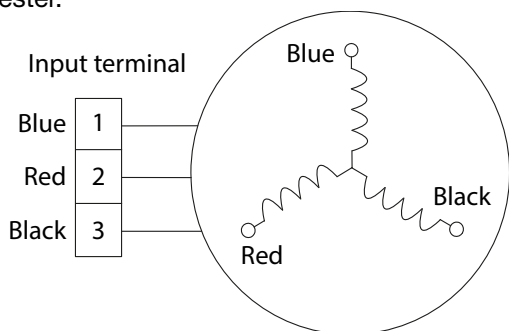

Position	Resistance Value		
	ASN108D22UEZ	DA130M1C-31FZ	DA150S1C-20FZ
Blue - Red			
Blue - Black	1,5 Ω (20 °C)	1,77 Ω (20 °C)	0,95 Ω (20 °C)
Red - Blue			



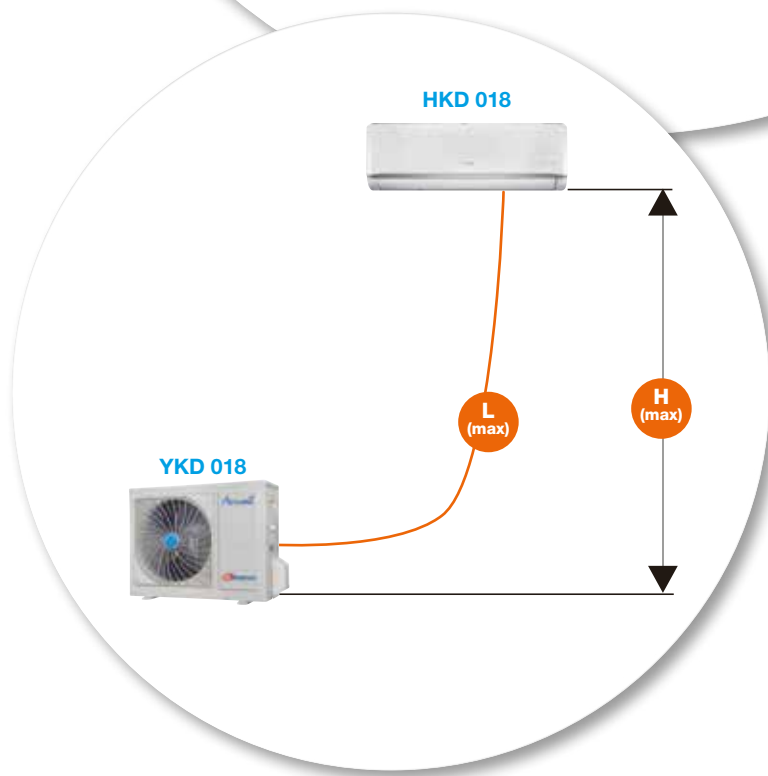
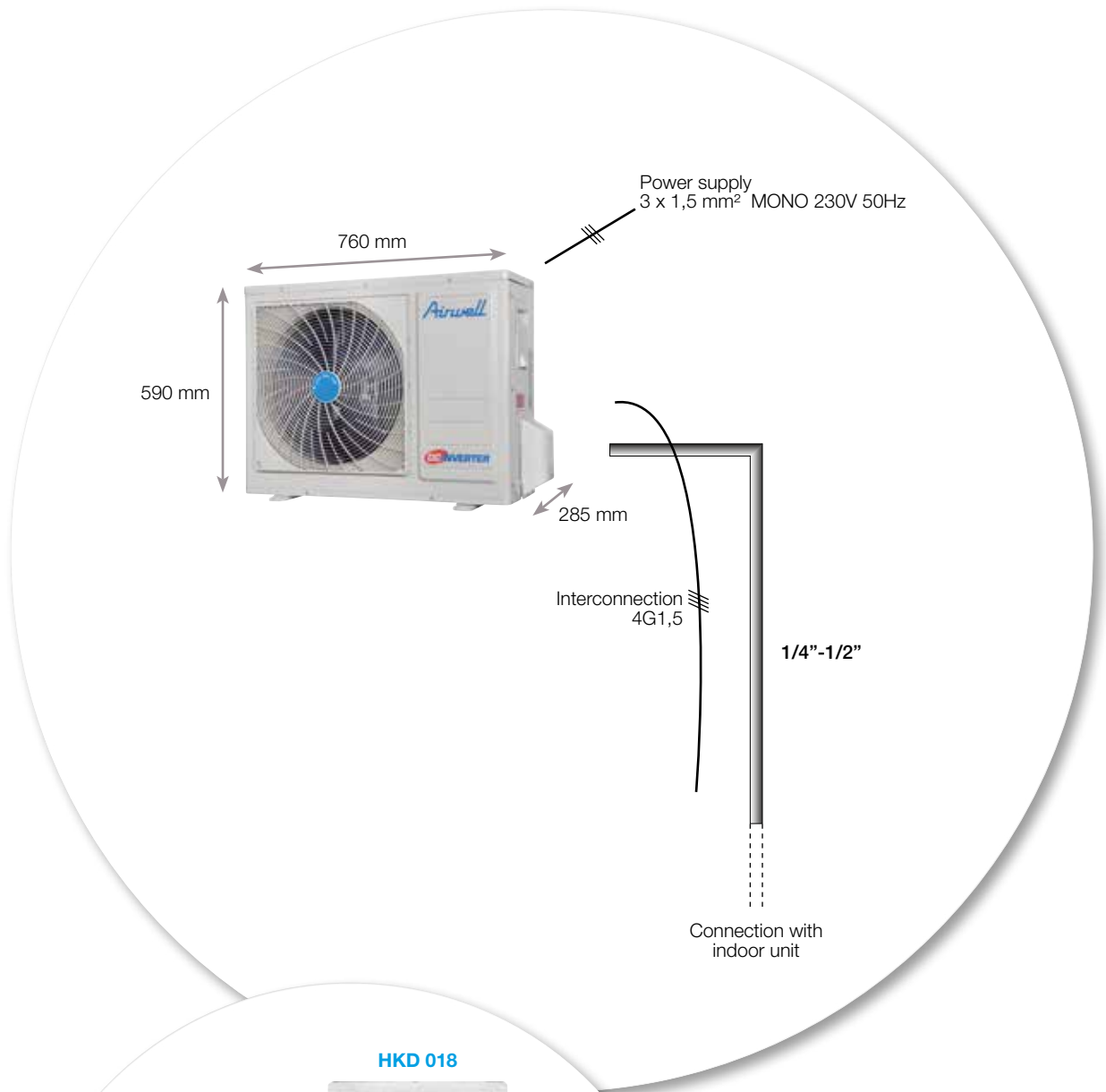

→ L(max) = 20 m

→ H(max) = 8 m

- Cable
- ▬ Pipe
- ≡≡≡ Number of wires

[FAULT CODE DISPLAY FROM HKD]

Displayed though IDU			Fault description
Display	LEDs	Displayed	
E0	☆ 1 time	□	IDU Bad EEPROM
E1	☆ 2 times	□	Communication failure IDU/ODU
E2	☆ 3 times	□	Zero crossing error (for HKD009 and HKD024)
E3	☆ 4 times	□	IFAN failure
E4	☆ 5 times	□	RAT failure
E5	☆ 6 times	□	ICT failure
EC	☆ 7 times	□	Refrigerant Leakage Detection
F1	☆ 2 times	■	OAT failure
F2	☆ 3 times	■	OCT failure
F3	☆ 4 times	■	CTT failure
F4	☆ 5 times	■	ODU Bad EEPROM
F5	☆ 6 times	■	OFAN failure
P0	☆ 1 times	☆	IPM fault
P1	☆ 2 times	☆	Over voltage / under voltage
P2	☆ 3 times	☆	Compressor overload
P4	☆ 5 times	☆	Compressor drive failure

□ LED light off / ■ LED light on / ☆ LED blink

[FAULT CODE DISPLAY FROM YKD]

Displayed though ODU			Description
Indoor fault code	LED2 (green)	LED3 (red)	
P1	■	■	Over voltage to low voltage protection
	■	□	Normal standby
	□	■	Normal operation
P4	□	☆	Compressor speed is abnormal
P4	☆	■	Compressor phase error
P0	☆	□	IGBT over current or IPM protection
P4	☆	☆	Communication error between ODU main chip and compressor drive chip

□ LED light off / ■ LED light on / ☆ LED blink

[OUTDOOR DC FAN MOTOR (CONTROL CHIP IS IN FAN MOTOR)]

→ Power on and when the unit is in standby, measure the voltage of pin1-pin3, pin4-pin3 in fan motor connector. If the value of the voltage is not in the range showing in below table, the PCB must has problems and need to be replaced.

DC motor voltage input and output			
N°	Color	Signal	Voltage
1	Red	Vs/Vm	280~380 V
2	-	-	-
3	Black	GND	0 V
4	White	Vcc	14~17,5 V
5	Yellow	Vsp	0~5,6 V
6	Blue	FG	14~17,5 V

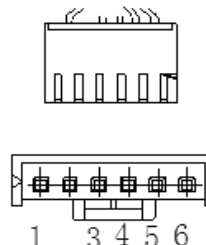

[SOME FREQUENTLY-USED R-T DATA FOR RAT, ICT, OCT, OAT SENSOR]

Temperature	°C	5	10	15	20	25	30	40	50	60
Resistance Value	kΩ	26,9	20,7	16,1	12,6	10	8	5,2	3,5	2,4

Remark:RAT - Room Air Thermistor. ICT - Indoor Coil Thermistor. OCT - Outdoor Coil Thermistor. OAT- Outdoor Air Thermistor.

[SOME FREQUENTLY-USED R-T DATA FOR CTT SENSOR]

Temperature	°C	5	15	25	35	60	70	80	90	100
Resistance Value	kΩ	141,6	88	56,1	36,6	13,8	9,7	6,9	5	3,7

Remark: CTT- Compressor Discharge Thermistor.

Our Aftersales Service

Export

Tél. ■ +33 (0)1 76 21 82 95

Fax ■ +33 (0)1 76 21 82 96

SPARE PARTS ORDERS:
e-mail ■ sp@airwell-res.com

TECHNICAL SUPPORT:
e-mail ■ technical-sp@airwell-res.com