

ROOFTECH RTCH: KIT SAV TUBING POUR 1 TANDEM COMPRESSEURS

F

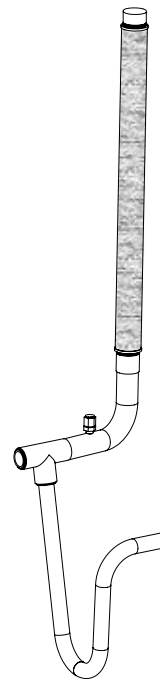

MISE HORS TENSION OBLIGATOIRE AVANT TOUTE INTERVENTION DANS LES BOITIERS ELECTRIQUES.



X1

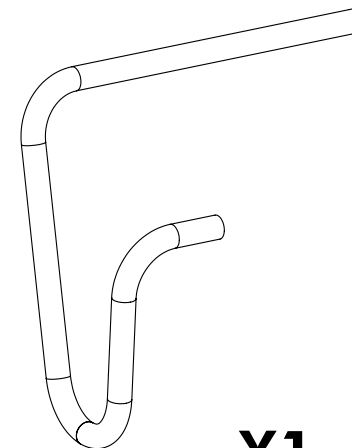

X1

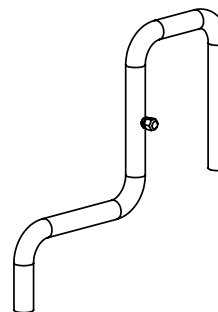

X1

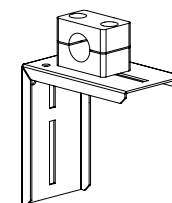

X1

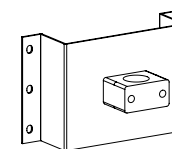

X1



1

Couper la tension avec le sectionneur principal de l'unité.

2

Vider le réfrigérant par la prise de pression du tube de refoulement, en récupérant le réfrigérant conformément à la norme EN378-4.



Ne pas vider le circuit frigorifique par la ligne d'aspiration (risque d'aspiration de l'huile des compresseurs).

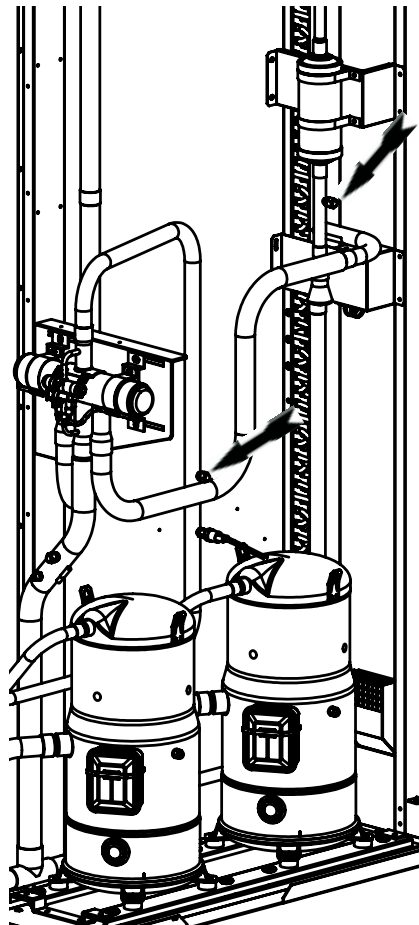

3

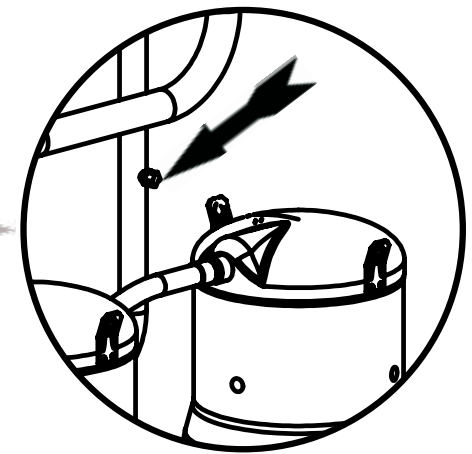
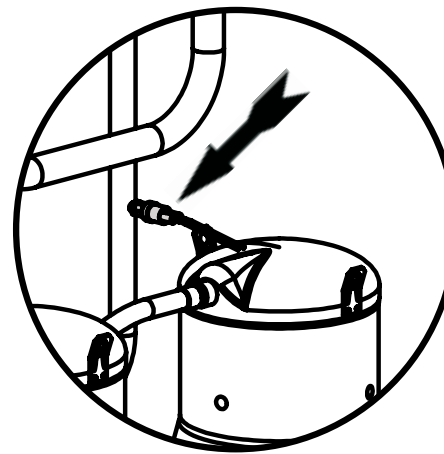
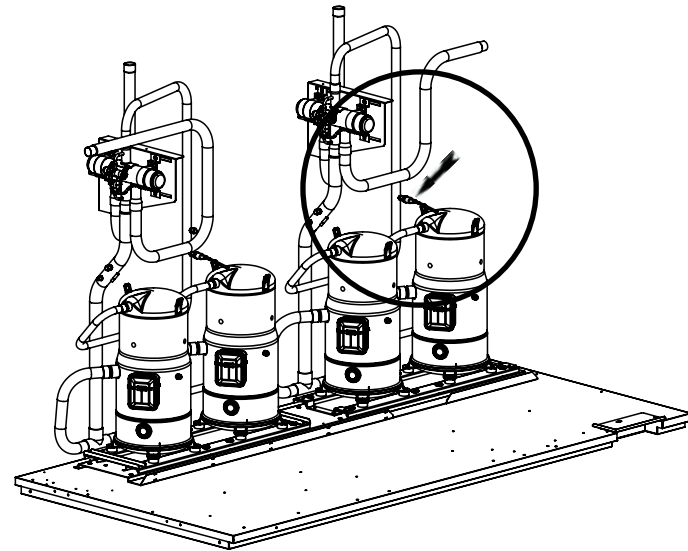

4

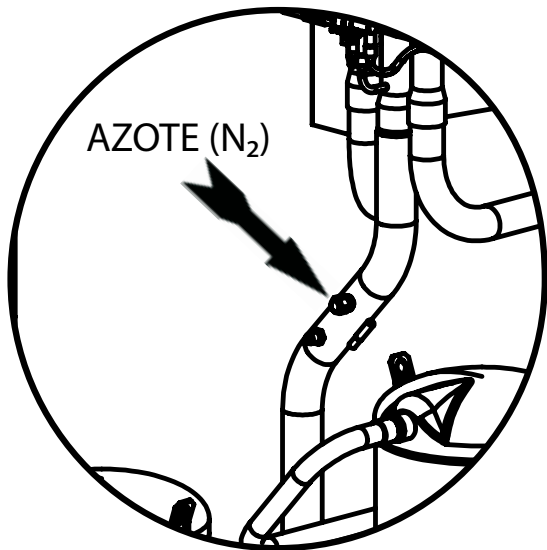
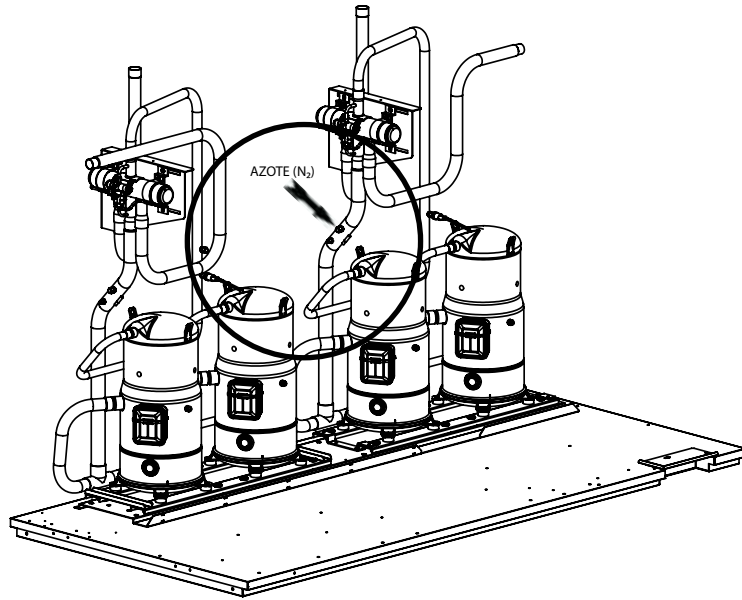

5

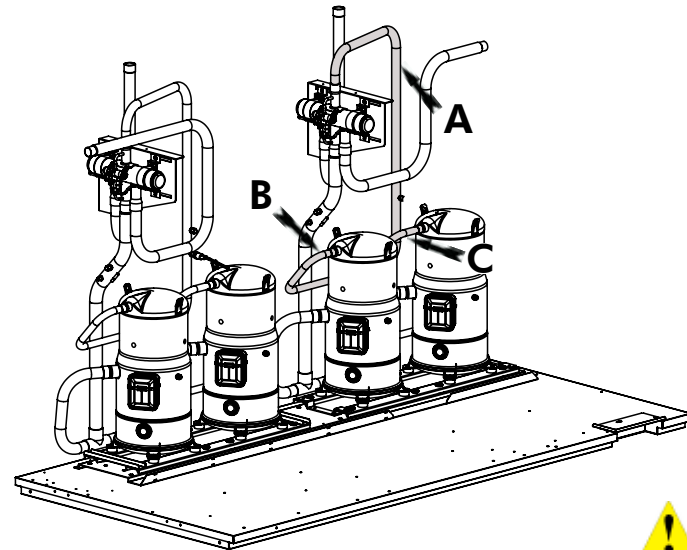

⚠
Couper sous azote

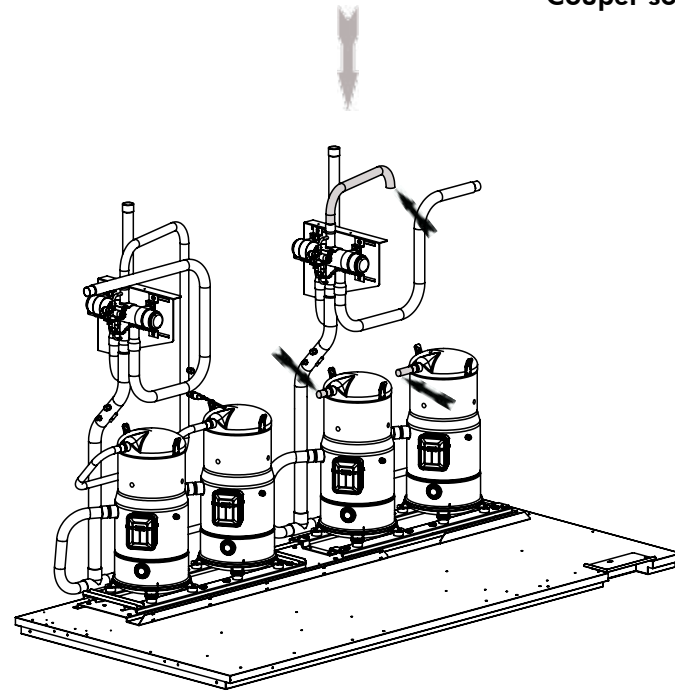

6

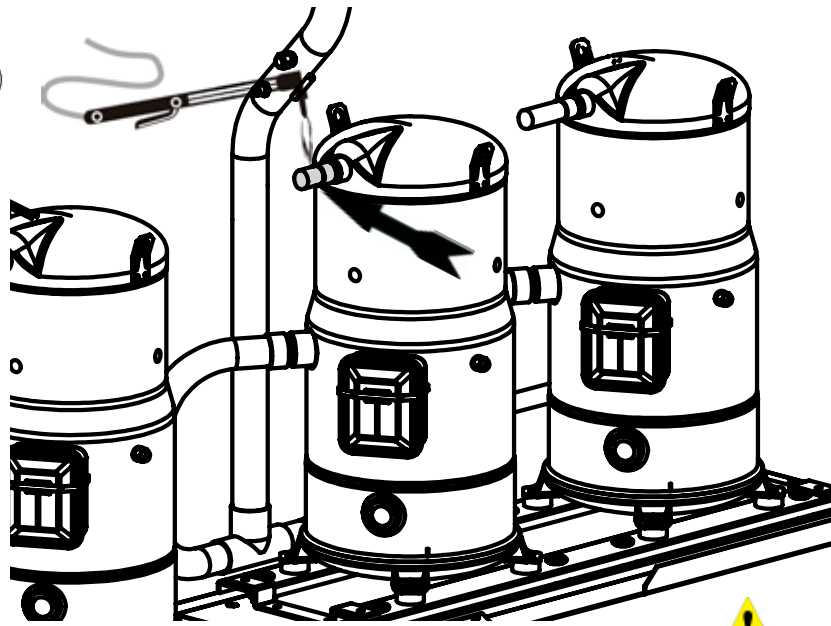

Débraser sous azote

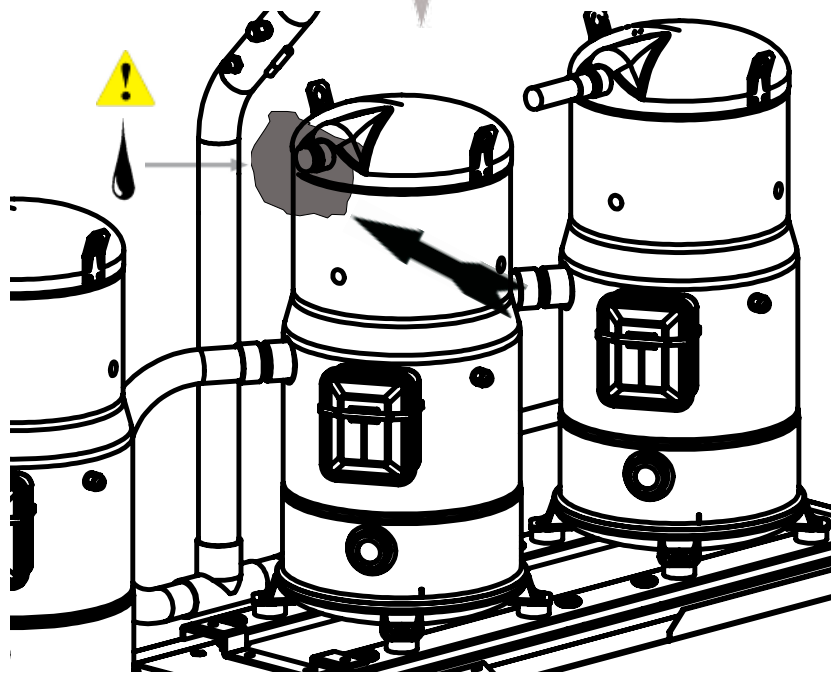

7

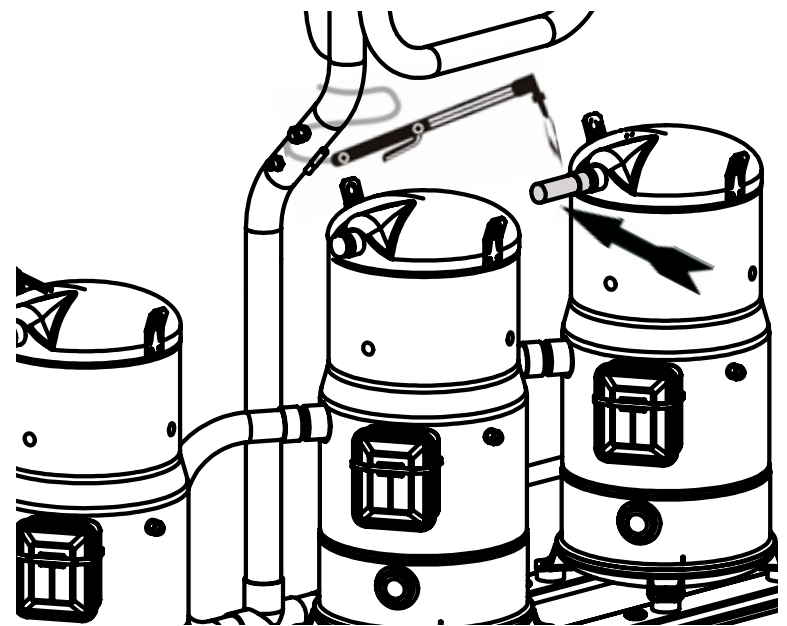

Débraser sous azote

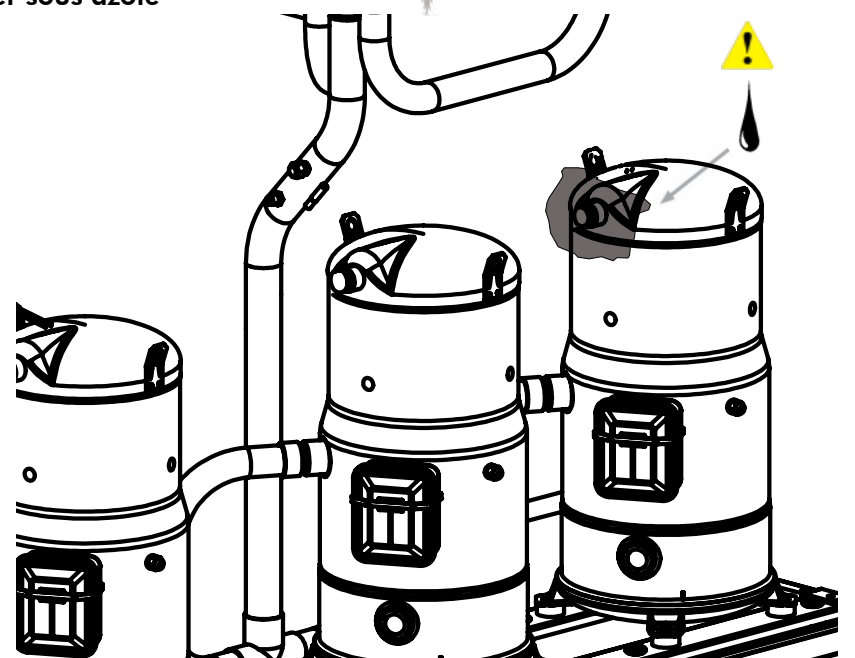

8

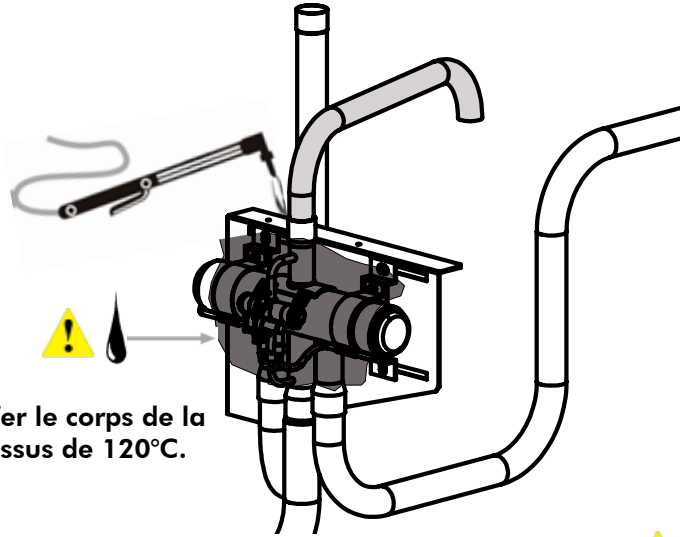

Ne pas chauffer le corps de la vanne au dessus de 120°C.

 Débraser sous azote

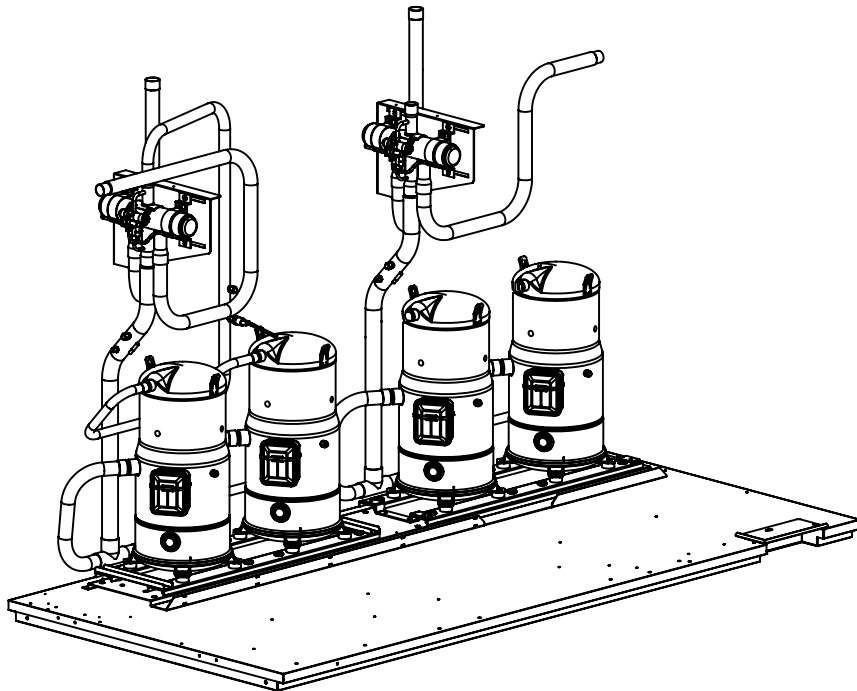

9

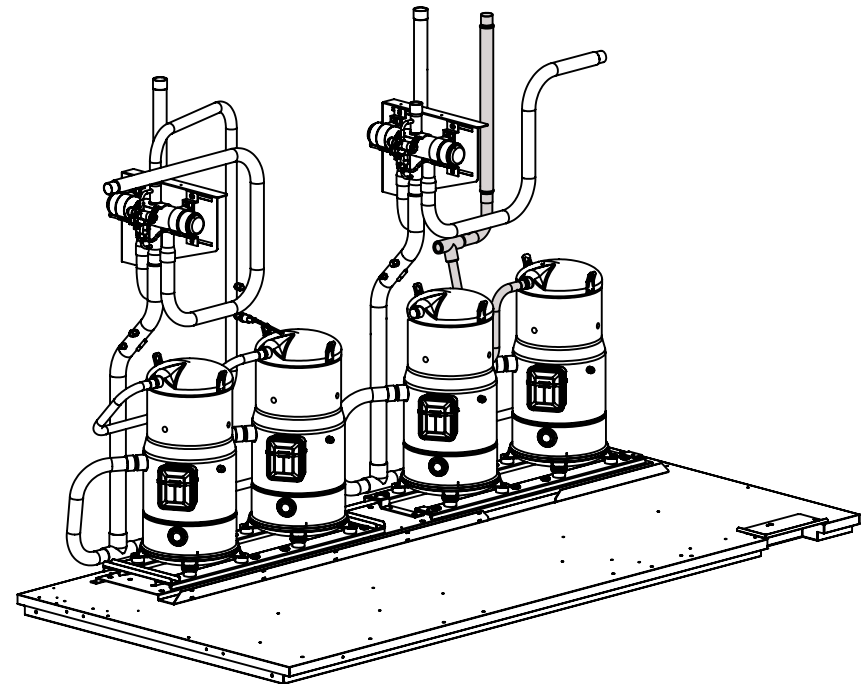
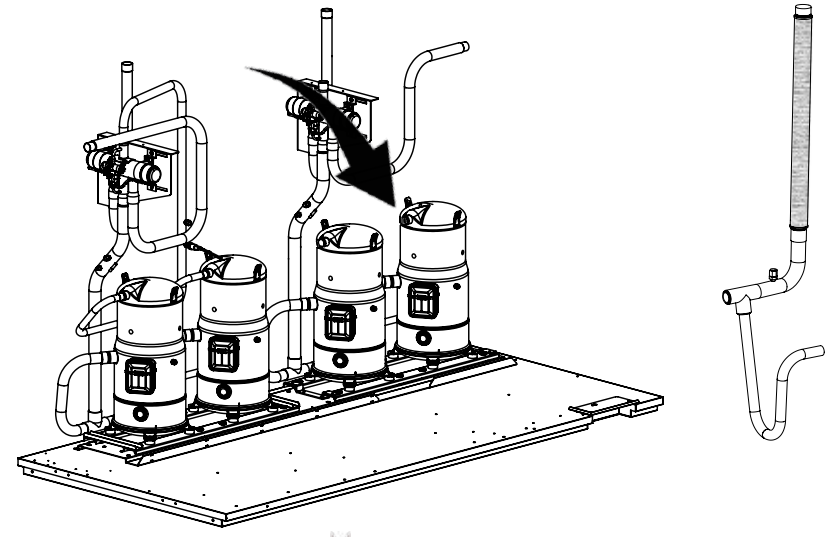

10

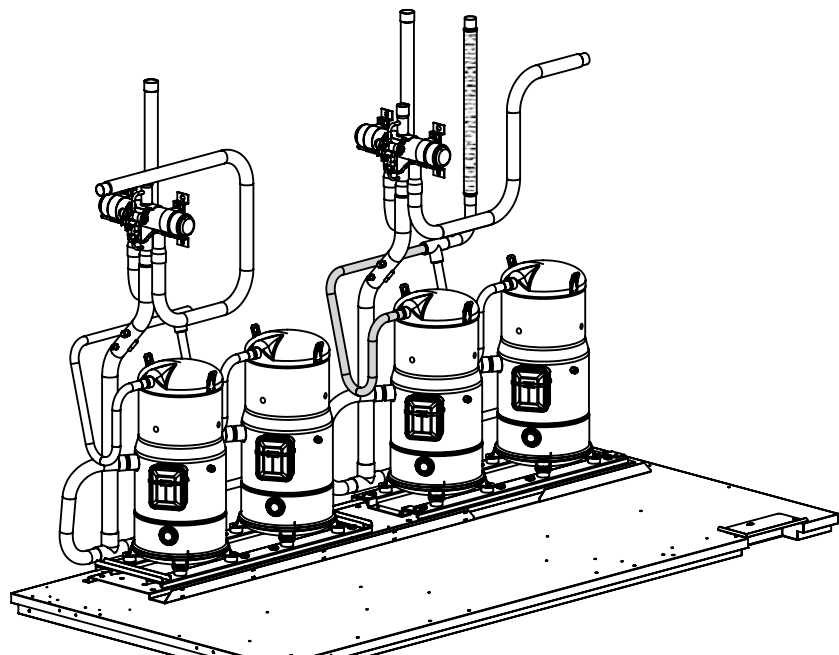
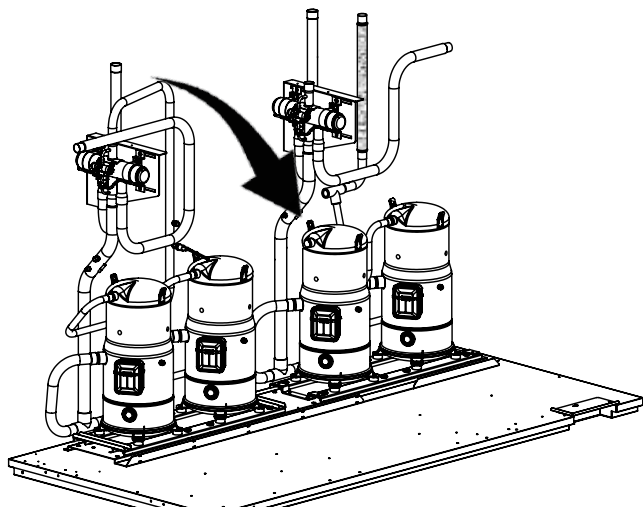

11

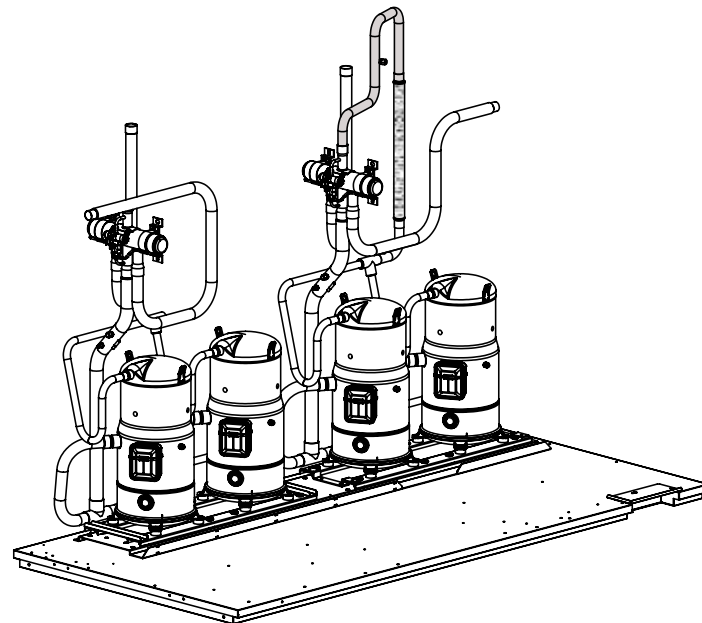
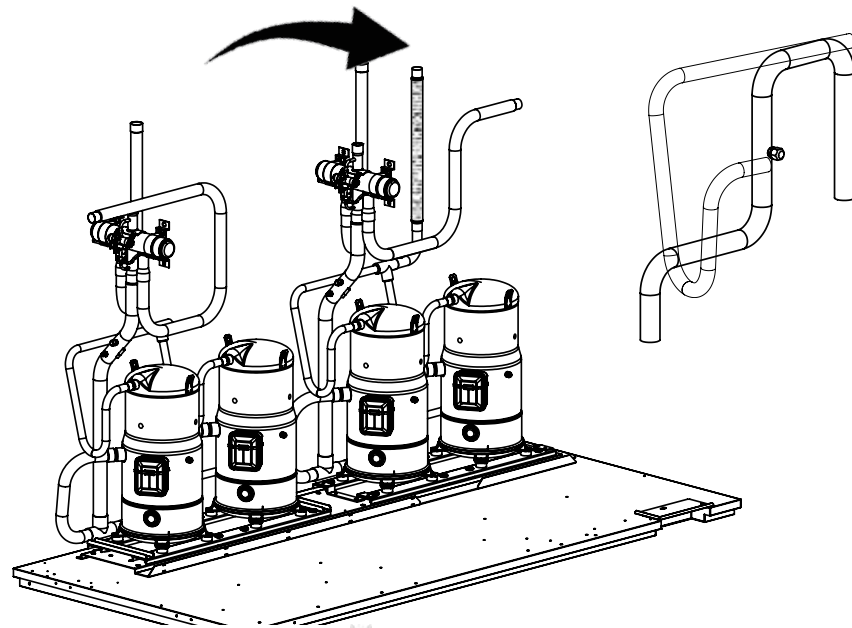

12

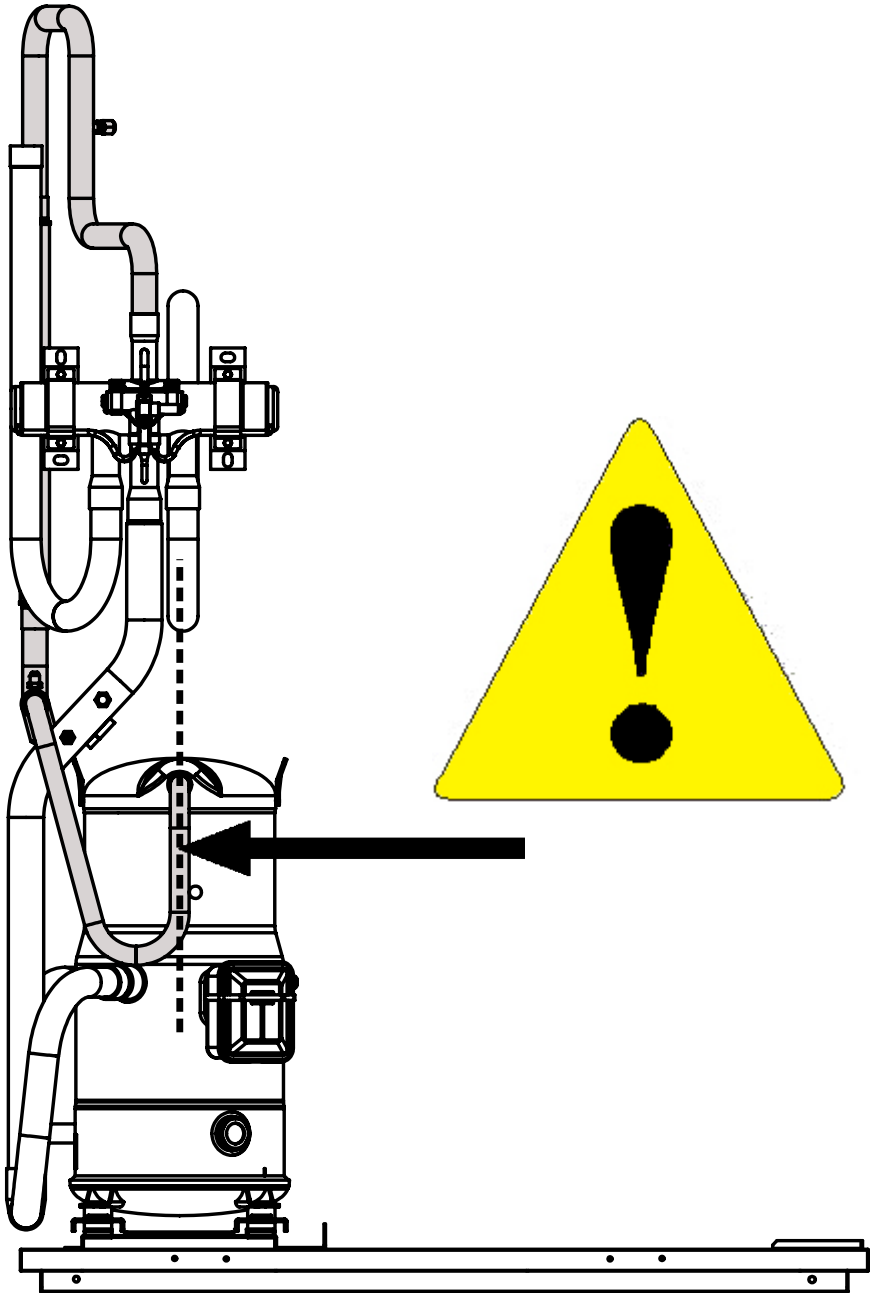

13

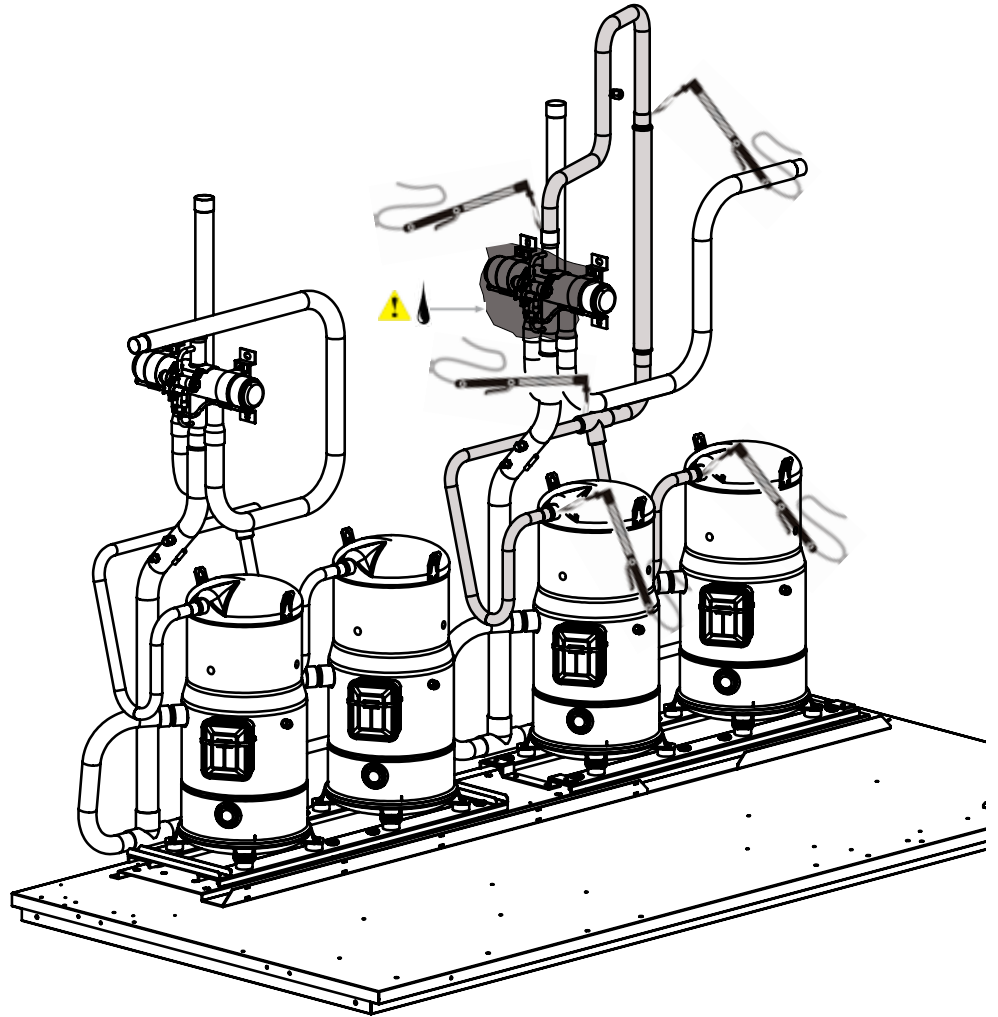

14

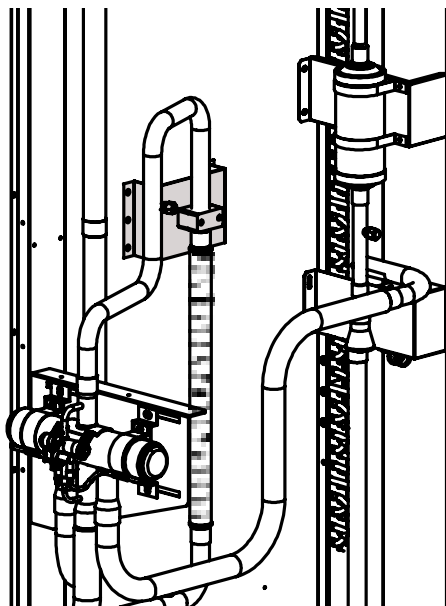
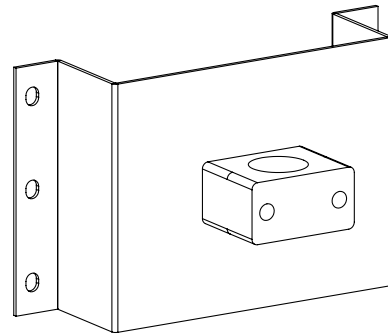
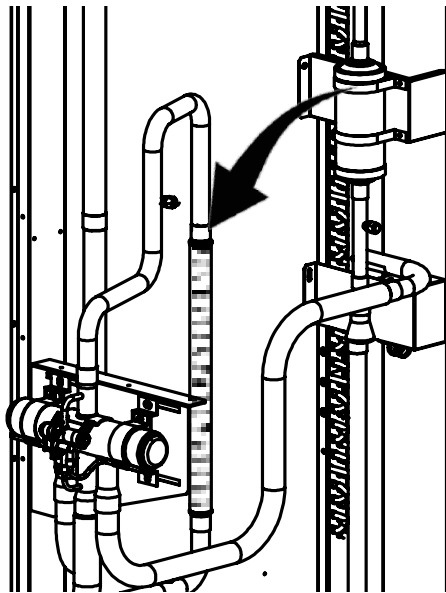

15

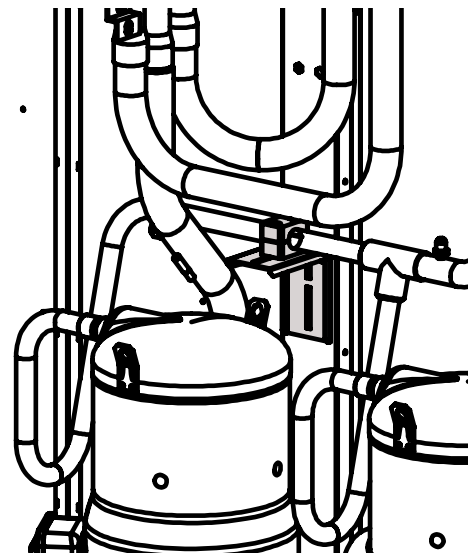
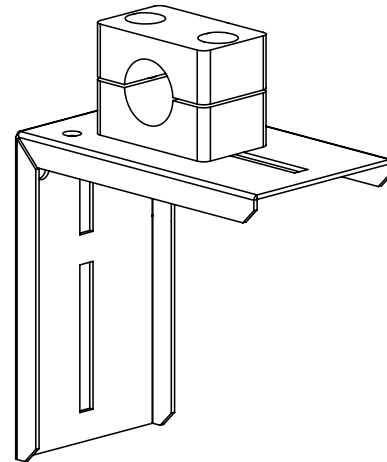
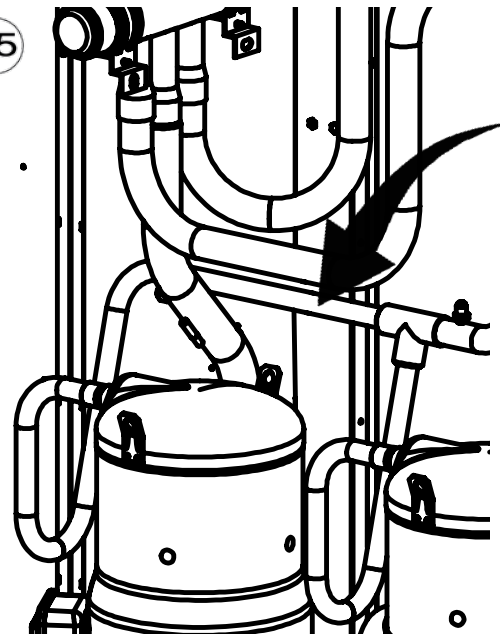

16

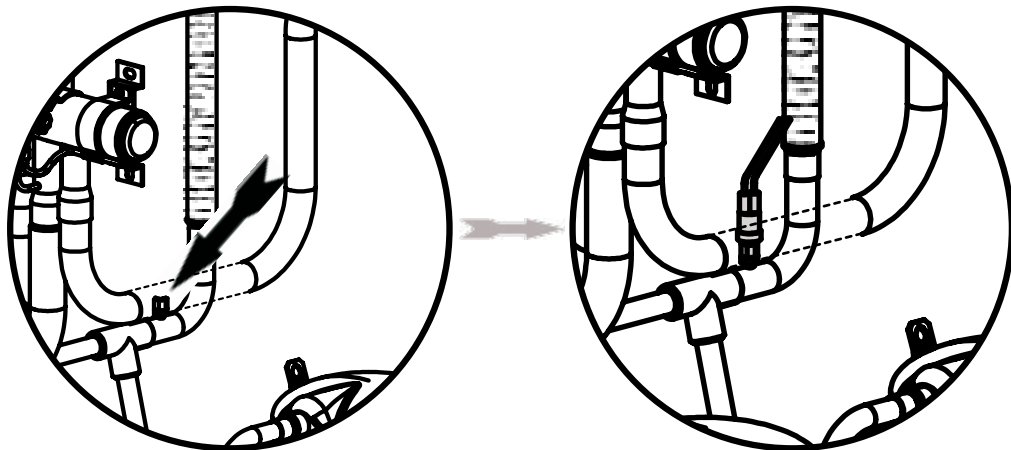
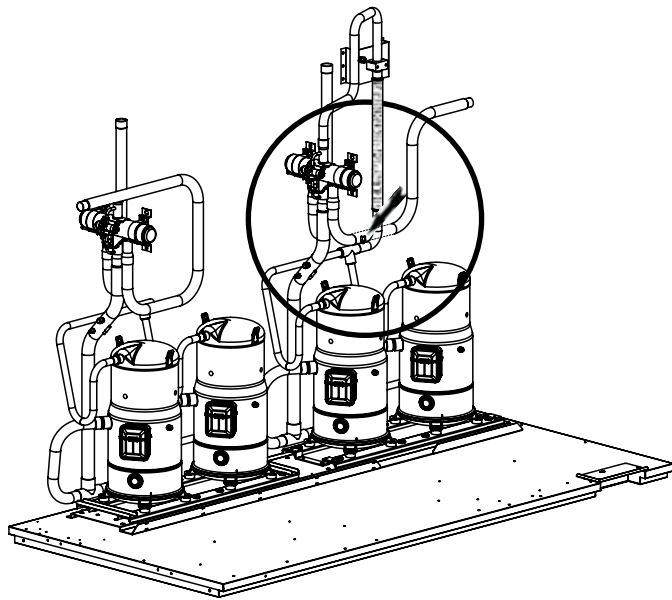

17

Suite à ces opérations, il est recommandé de remplacer le déshydrateur du circuit concerné.

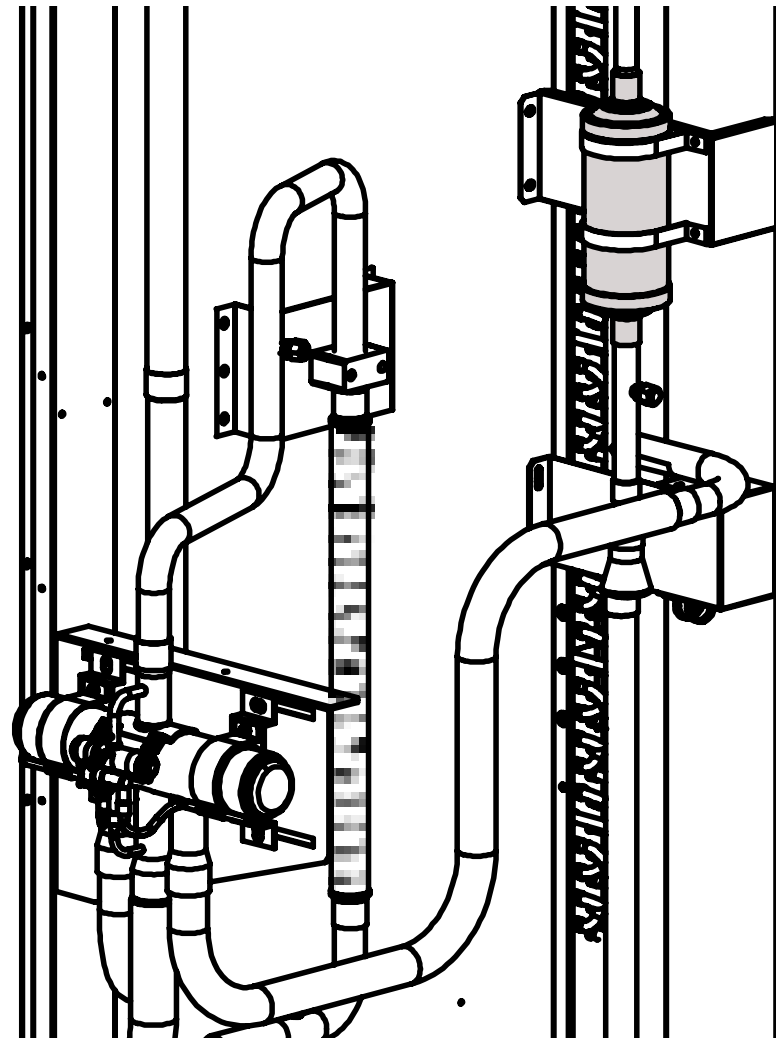

18

Procéder au tirage au vide du circuit frigorifique en deux points (VUS HP et VUS BP).

Le tirage au vide est correct lorsqu'une pression de 10 mbar est atteinte.

Lorsque le circuit est en dépression vérifier les niveaux d'huile des compresseurs. Si besoin compléter la quantité d'huile en raccordant un tuyau avec prise de type manifold au raccord spécifique sur le compresseur.



Référence de l'huile POE pour compresseur SH120-161-184 :

- Désignation : 160SZ
- Quantité par compresseur :
 - SH120 : 3.3L
 - SH161 : 3.3L
 - SH184 : 3.6L

19

Charger le circuit avec la charge plaquée sur l'unité par le côté refoulement (au plus proche du condenseur).

20

Mettre l'unité sous tension, et préchauffer les compresseurs avec les résistances de carter (10 à 12 heures).

21

Procéder au démarrage de l'unité, et compléter la charge par le côté aspiration si besoin par tranches maximum de 500g.



Lors de cette opération, il faut impérativement vérifier l'absence de mousse au niveau du voyant d'huile de chaque compresseur.

22

Vérifier les paramètres thermodynamiques de l'unité.

23

Contrôler visuellement les vibrations du tubing.

