



# Installation Manual

WELLEA HT

Air to Water heat pump

*EN*



Dear Customer,

Thank you for purchasing this device.

We invite you to read this manual carefully before using your appliance. Keep this document in a safe place for future reference.

To ensure safe and efficient operation, we recommend that you carry out the necessary maintenance operations regularly. Our After-Sales service can help you with these operations.

We hope that you will be satisfied with our services for many years.

**AIRWELL**

This manual is referring to the following unit :

Designation	Code
<b>BDHW-040R-04M25</b>	
<b>BDHW-060R-04M25</b>	
<b>BDHW-080R-04M25</b>	
<b>BDHW-100R-04M25</b>	
<b>BDHW-120R-04M25</b>	
<b>BDHW-140R-04M25</b>	
<b>BDHW-160R-04M25</b>	
<b>BDHW-120R-04T35</b>	
<b>BDHW-140R-04T35</b>	
<b>BDHW-160R-04T35</b>	



The data contained in this manual are not binding and may be modified by the manufacturer without prior notice.

## SUMMARY

1. SAFETY PRECAUTIONS .....	9
1.1. Symbols on the unit.....	9
1.2. Target group.....	9
1.3. Intended use.....	9
1.4. Regulations to be observed .....	10
1.5. Safety instructions for working on the system.....	10
1.6. Working in the safety zone .....	10
1.7. Working on the system.....	11
1.8. Working on the refrigerant circuit .....	11
1.9. About the Refrigerant .....	12
1.10. Leak detection .....	14
1.11. Disposal.....	14
2. INTRODUCTION.....	15
2.1. Validity of the instructions .....	15
2.2. Unpacking .....	15
2.3. Accessories of the unit .....	16
2.4. Transportation .....	17
2.4.1. Dimensions and barycenter .....	17
2.4.2. Manual transportation.....	18
2.4.3. Lifting.....	18
2.5. Parts to be Removed .....	18
2.6. Operating range .....	19
2.7. Hydraulic Module.....	20
3. SAFETY ZONE .....	21
4. INSTALLATION.....	22
4.1. Conditions for Installation.....	22
4.2. Installation Site.....	23
4.2.1. Precautions for installation on a ground.....	24
4.2.2. Precautions for installation on a flat roof.....	24
4.2.3. Occupational safety.....	24
4.3. Foundation and Unit Installation.....	24
4.3.1. Installation on a ground.....	24
4.3.2. Installation on a flat roof.....	25
4.4. Drainage.....	25
4.4.1. Drain hole position.....	25
4.4.2. Drainage layout (installation on a ground) .....	25
4.5. Cold Climates .....	27
4.6. Exposure to Strong Sunlight .....	27
5. SYSTEM DESIGN.....	27
5.1. Capacity and Load Curve.....	27
5.2. DHW Tank (Supplied by the User).....	27
5.3. Room Thermostat (Supplied by the User) .....	28
5.4. Solar Kit for DHW Tank (Supplied by the User).....	28

5.5.	Balance Tank (Supplied by the User)	28
5.6.	Additional Expansion Vessel	28
5.7.	Circulation Pump	29
5.8.	Thermistor	30
6.	TYPICAL INSTALLATIONS	31
6.1.	Controlled through the wired controller	31
6.1.1.	Single-zone control	31
6.1.2.	Double-zone control	32
6.2.	Control through the wired controller and room thermostat	33
6.2.1.	Single-zone control	33
6.2.2.	Control through mode setting	34
6.2.3.	Double-zone control	35
7.	HYDRAULIC INSTALLATION	36
7.1.	Preparations for Installation	36
7.1.1.	Minimum water volume	36
7.1.2.	Maximum water volume	36
7.1.3.	Flow rate range	36
7.1.4.	Pre-pressure adjustment of the expansion vessel	36
7.1.5.	Requirements for third-party tanks	36
7.1.6.	Thermistor of domestic hot water tank	37
7.1.7.	Requirements for balance tank volume	37
7.1.8.	Field connection of hydraulics parts	37
7.2.	Water Circuit Connection	37
7.3.	Water	38
7.4.	Filling Water Loop with Water	39
7.5.	Filling Domestic Hot Water Tank with Water	39
7.6.	Water Pipe Insulation	39
7.7.	Freeze Protection	39
7.7.1.	Protected by software	39
7.7.2.	Protected by glycol	40
7.7.3.	About freeze protection valves (field supplied)	40
7.7.4.	Measure without freeze protection	41
7.7.5.	Freeze protection for water circuit	41
7.8.	Check of Water Circuit	41
8.	ELECTRICAL INSTALLATION	42
8.1.	Opening the Electrical Box Cover	42
8.2.	Opening the Electrical Box Cover	43
8.3.	Opening the Electrical Box Cover	44
8.3.1.	Field wiring guidelines	44
8.3.2.	Operating current and wire diameter	44
8.3.3.	Tightening torque and tie wrap	45
8.3.4.	Back plate layout for wiring	45
8.4.	Connection with Power Supply	45
8.4.1.	Precautions	45

8.4.2.	Wiring of main power supply .....	46
8.5.	Control board.....	48
8.5.1.	Main control board.....	48
8.6.	Connection of Other Components.....	50
8.6.1.	Wiring of additional heat source control (AHS) .....	51
8.6.2.	Wiring of 3-way valves SV1, SV2 and SV3.....	51
8.6.3.	Wiring of additional pumps .....	52
8.6.4.	Wiring of tank booster heater (TBH) .....	54
8.6.5.	Wiring of alarm or defrost run (P_x).....	54
8.6.6.	Wiring of room thermostat (RT).....	55
8.6.7.	Wiring of solar energy input signal (low voltage) .....	56
8.6.8.	Wiring of remote shutdown .....	56
8.6.9.	Wiring of smart grid .....	57
8.7.	Cascade Function .....	58
8.8.	Connection for Other Optional Components.....	59
8.8.1.	Wiring of drainage pipe heating tape .....	59
9.	INSTALLATION OF WIRED CONTROLLER.....	60
9.1.	Materials for Installation .....	60
9.2.	Dimensions.....	60
9.3.	Wiring .....	61
9.4.	Mounting.....	62
10.	COMPLETION OF INSTALLATION.....	63
11.	CONFIGURATION .....	64
11.1.	Check Before Configuration .....	64
11.2.	Configuration .....	65
11.2.1.	DHW setting .....	65
11.2.2.	Cooling setting.....	65
11.2.3.	Heating setting .....	66
11.2.4.	Auto mode setting .....	66
11.2.5.	Temp. type setting.....	66
11.2.6.	Room thermostat setting .....	66
11.2.7.	Other heat source.....	67
11.2.8.	Holiday away setting .....	67
11.2.9.	Holiday away setting .....	67
11.2.10.	Restoration of factory settings.....	68
11.2.11.	Test run .....	68
11.2.12.	Special function .....	68
11.2.13.	Auto restart.....	69
11.2.14.	Power input limitation .....	69
11.2.15.	Input definition .....	69
11.2.16.	Cascade setting.....	70
11.2.17.	HMI address setting .....	70
11.2.18.	Common setting .....	70
11.3.	Configuration .....	71

12. COMMISSIONING .....	74
12.1. Test Run for the Actuator .....	74
12.2. Air Purge .....	75
12.3. Test Run .....	75
12.4. Check of the Minimum Flow Rate .....	76
13. HAND-OVER TO THE USER .....	76
13.1. Energy Saving Tips .....	76
13.2. Additional Operation Reference .....	77
13.2.1. Mode .....	77
13.2.2. Schedule .....	77
13.2.3. Weather temp. setting .....	77
13.2.4. DHW setting .....	80
13.2.5. Options .....	81
13.2.6. Unit status .....	81
13.2.7. Error info .....	81
13.2.8. FAQ .....	81
14. TROUBLESHOOTING .....	82
14.1. General Guidelines .....	82
14.2. Typical Abnormalities .....	82
14.3. Error Codes .....	84
15. MAINTENANCE .....	85
15.1. Safety Precautions for Maintenance .....	85
15.2. Annual Maintenance .....	85
15.2.1. Water pressure .....	85
15.2.2. Water strainer .....	85
15.2.3. Water pressure relief valve .....	85
15.2.4. Pressure relief valve hose .....	85
15.2.5. Insulation cover of backup heater .....	85
15.2.6. Pressure relief valve of domestic hot water tank (supplied by the user) .....	85
15.2.7. Booster heater of domestic hot water tank .....	85
15.2.8. Switch box of the unit .....	85
15.2.9. Temperature sensor .....	85
15.2.10. Temperature sensor .....	85
15.2.11. Refrigerant leakage check .....	85
15.2.12. Flow switch failure .....	86
16. SERVICE INFORMATION .....	86
16.1. Label for Refrigerant Presence .....	86
16.2. Leak Detection Methods .....	86
16.3. Check of Refrigeration Equipment .....	86
16.4. Check of Electrical Devices .....	86
16.5. Repair of Sealed Components .....	87
16.6. Repair of Intrinsically Safe Components .....	87
16.7. Transportation and Marking .....	87
17. DISPOSAL .....	87

17.1.	Refrigerant Removal, Evacuation, Charge, Recovery, and Unit Decommissioning .....	87
18.	TECHNICAL DATA .....	89
18.1.	General.....	89
18.2.	Electrical Specifications.....	89
18.3.	Piping Diagram.....	90
19.	ANNEX.....	93
19.1.	Menu Structure (Wired Controller) .....	93



## 1. SAFETY PRECAUTIONS

Meaning of DANGER, WARNING, CAUTION and NOTE.

### **DANGER**

Indicates an imminently hazardous situation which, if not avoided, will result in death or serious injury.

### **WARNIG**

Indicates a potentially hazardous situation which, if not avoided, could result in death or serious injury.



### **CAUTION**

Indicates a potentially hazardous situation which, if not avoided, may result in minor or moderate injury. This term can also be used as a warning in case of insufficiently safe procedures.

### **NOTE**

Indicates situations that may cause only accidental damage to equipment or other property.

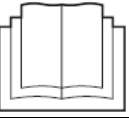
### 1.1.Symbols on the unit

	WARNING	Flammable refrigerant is applied. A fire may occur due to unexpected leakage of refrigerant.
	CAUTION	Read the operation manual carefully before any further action.
	CAUTION	Only a specialist is allowed to take action under the instructions of the installation manual.
	CAUTION	The information is available in the relevant documentation.

### 1.2.Target group

### **DANGER**

These instructions are exclusively intended for qualified contractors and authorized installers.

- Work on the refrigerant circuit with flammable refrigerant in safety group A3 may only be carried out by authorized heating contractors. These heating contractors must be trained in accordance with EN 378 Part 4 or IEC 60335-2-40, Section HH. The certificate of competence from an industry accredited body is required.

- Brazing/soldering work on the refrigerant circuit may only be carried out by personnel certified in accordance with ISO 13585 and AD 2000, Datasheet HP 100R. And only contractors qualified and certified for the processes can perform brazing/soldering work.

The work must fall within the range of applications purchased and be carried out in accordance with the prescribed procedures. Soldering/brazing work on accumulator connections requires certification of personnel and processes by a notified body according to the Pressure Equipment Directive (2014/68/EU).

- Work on electrical equipment may only be carried out by a qualified electrician. Before initial commissioning, all safety-related points must be checked by the particular certified heating contractors. The system must be commissioned by the system installer or a qualified person authorized by the installer.

### 1.3.Intended use

There is a risk of injury or death to the user or others, or of damage to the product and other property in the event of improper or unintended use.

The product is the outdoor unit of an air-to-water heat pump with monoblock design.

The product uses the outdoor air as a heat source and can be used to heat a residential building and generate domestic hot water.

The air that escapes from the product must be able to flow out freely, and must not be used for any other purposes.

The product is only intended for outdoor installation.

The product is intended exclusively for domestic use, which means that the following places are not appropriate for installation:

- Where there is mist of mineral oil or oil spray or vapors. Plastic parts may deteriorate, and cause joint loose and leakage of water.

- Where corrosive gases (such as sulfurous acid gas) are produced, or corrosion of copper pipes or soldered parts may cause leakage of refrigerant.

- Where there is machinery which emits massive electromagnetic waves. Enormous electromagnetic waves can disturb the control of the system and cause equipment malfunction.

- Where flammable gases may leak, carbon fiber or ignitable dust is suspended in the air or volatile flammables such as paint thinner or gasoline are handled. These types of gases might cause a fire.

- Where the air contains high levels of salt such as a location near the ocean.

- Where voltage fluctuates a lot, such as a location in a factory.

- In vehicles or vessels.

- Where acidic or alkaline vapors are present.

Intended use includes the following:

- Observance of the operating instructions included for the product and any other installation components.

- Compliance with all inspection and maintenance conditions listed in the instructions.

- Installing and setting up the product in accordance with the product and system approval.

- Installation, commissioning, inspection, maintenance and troubleshooting by qualified contractors and authorized installers.

Intended use also covers installation in accordance with the IP code.

This appliance can be used by children aged from 8 years and above and persons with reduced physical, sensory or mental capabilities or lack of experience and knowledge provided that they have been given supervision or instruction concerning the use of the appliance in a safe way and understand the hazards involved. Children should not play with the appliance. Cleaning and maintenance should not be made by children without supervision. Any other use that is not specified in these instructions, or use beyond that specified in this document, should be considered as improper use. Any direct commercial or industrial use is also deemed to be improper.

### **CAUTION**

*Improper use of any kind is prohibited.*

- Do not rinse the unit.
- Do not place any object or equipment on top of the unit (top plate).
- Do not climb, sit or stand on top of the unit.

## 1.4.Regulations to be observed

- 1.National installation regulations.
- 2.Statutory regulations for the prevention of accidents.
- 3.Statutory regulations for environmental protection.
- 4.Statutory requirements for pressure equipment: Pressure Equipment Directive 2014/68/EU.
- 5.Codes of practice of the relevant trade associations.
- 6.Relevant country-specific safety regulations.
- 7.Applicable regulations and guidelines for operation, service, maintenance, repair and safety of cooling, air conditioning and heat pump systems containing flammable and explosive refrigerant.

## 1.5.Safety instructions for working on the system

The outdoor unit contains flammable refrigerant R290 (propane C3H8). In case of a leak, the escaping refrigerant may form a flammable or explosive atmosphere in the ambient air. A safety zone is defined in the immediate vicinity of the outdoor unit, in which special rules apply when work is performed on the appliance. See section "Safety zone".

## 1.6.Working in the safety zone

### **DANGER**

*Risk of explosion: Refrigerant leak may form a flammable or explosive atmosphere in the ambient air. Take the following measures to prevent fire and explosion in the safety zone:*

- Keep ignition sources away, including naked flames, plug sockets, hot surfaces, light switches, lamps, electrical devices not free of ignition sources, mobile devices with integrated batteries (such as mobile phones and fitness watches).
- Do not use any sprays or other combustible gases in the safety zone.

### **CAUTION**

*Permissible tools: All tools for working in the safety zone must be designed and explosion-protected in accordance with the applicable standards and regulations for refrigerant in safety groups A2L and A3, such as brushless machines (cordless disposal containers, installation aids, and screwdrivers), extraction equipment, vacuum pumps, conductive hoses, and mechanical tools of non-sparking material.*

### **NOTE**

*The tools must also be suitable for the pressure ranges in use. Tools must be in perfect maintenance conditions.*

- The electrical equipment must meet the requirements for areas at risk of explosion, zone 2.
- Do not use flammable materials such as sprays or other flammable gases.
- Before starting work, discharge static electricity by touching grounded objects, such as heating or water pipes.
- Do not remove, block or bridge safety equipment.
- Do not make any changes: Do not modify the outdoor unit, inlet/ outlet lines, electrical connections/ cables or the surroundings. Do not remove any components or seals.

## 1.7. Working on the system

Switch off the power supply for the unit (including all affiliated parts) at a separate fuse or mains isolator. Check and ensure that the system is no longer live.

### **NOTE**

*In addition to the control circuit there may be several power circuits.*

### **DANGER**

*Contact with live components can result in severe injuries. Some components on PCBs remain live even after the power supply has been switched off. Prior to removing covers from the appliances, wait at least 4 minutes until the voltage has completely dropped out.*

- Safeguard the system against re-connection.
- Wear suitable personal protective equipment when carrying out any work.
- Do not touch any switch or electrical parts with wet fingers. It may cause electrical shock and compromise the system.

### **DANGER**

*Hot surfaces and fluids can result in burns or scalding. Cold surfaces may cause frostbite.*

- Prior to servicing or maintenance tasks, switch off and allow the equipment to cool down or warm up.
- Do not touch hot or cold surfaces on the appliance, fittings or pipework.

### **NOTE**

*Electronic assemblies can be damaged by electrostatic discharge. Before beginning work, touch earthed objects, such as heating or water pipes, to discharge any static.*

Safety work area and temporary flammability zones.

### **CAUTION**

*When working on systems using flammable refrigerants, the technician should consider certain locations as “temporary flammable zones”. These are normally regions where at least some emission of refrigerant is anticipated to occur during the normal working procedures, such as recovery, charging and evacuation, typically where hoses may be connected or disconnected. The technician should ensure three meters safety working area (radius of the unit) in case of any accidental release of refrigerant that forms a flammable mixture with air.*

## 1.8. Working on the refrigerant circuit

R290 refrigerant (propane) is an air displacing, colorless, flammable, odorless gas which forms explosive mixtures with air. Refrigerant drained must be properly disposed of by authorized contractors. Perform the following measures before beginning

work on the refrigerant circuit:

- Check the refrigerant circuit for leaks.
- Ensure very good ventilation especially in the floor area and maintain this for the duration of the work.
- Secure the area surrounding the work area.
- Inform the following persons of the type of work to be carried out: – All maintenance personnel – All persons in the vicinity of the system.
- Inspect the area immediately around the heat pump for flammable materials and ignition sources: Remove all flammable materials and ignition sources.
- Before, during and after the work, check the surrounding area for escaping refrigerant using an explosion-proof refrigerant detector suitable for R290. This refrigerant detector must not generate any sparks and must be suitably sealed.
- A CO2 or powder extinguisher must be available in the following cases: –Refrigerant is being drained. – Refrigerant is being topped up. – Soldering or welding work is in progress.
- Display signs prohibiting smoking.

### **DANGER**

*Escaping refrigerant can lead to fires and explosions that result in very serious injuries or death.*

- Do not drill or apply heat to a refrigerant circuit filled with refrigerant.
- Do not operate Schrader valves unless a fill valve or extraction equipment is attached.
- Take measures to prevent electrostatic charge.
- Do not smoke. Avoid naked flames and sparks. Never switch lights or electrical appliances on or off in environments with naked flames or sparks.
- Components that contain or contained refrigerant must be labeled, and stored in well-ventilated areas in accordance with the applicable regulations and standards.

### **DANGER**

*Direct contact with liquid or gaseous refrigerant can cause serious damage to health such as frostbite and/or burns. There is a risk of asphyxiation if liquid or gaseous refrigerant is breathed in.*

- Prevent direct contact with liquid or gaseous refrigerant.
- Wear personal protective equipment when handling liquid or gaseous refrigerant.
- Never breathe in any refrigerant vapor.

### **DANGER**

*Refrigerant is under pressure: Mechanical loading of lines and components can cause leaks in the refrigerant circuit. Do not apply loads to the lines or components, such as supporting or placing tools.*

## 1.9>About the Refrigerant

### **WARNIG**

- The following applies to R290 refrigerant systems.
- Prior to work on systems containing flammable refrigerants, safety checks are necessary to minimize the risk of ignition.

For repair of the refrigerating system, the following precautions should be complied with prior to conducting work on the system.

Work should be undertaken under a controlled procedure so as to minimize the risk of a flammable gas or vapor being present while the work is being performed.

All maintenance staff and others working in the local area should be instructed on the nature of work being carried out. Work in confined spaces should be avoided. The area around the workspace should be sectioned off. Ensure that the area is safe through control of flammable materials.

The area should be checked with an appropriate refrigerant detector prior to and during work, to ensure the technician is aware of potentially flammable atmospheres.

Ensure that the leak detection equipment being used is suitable for use with flammable refrigerants, i.e. , the equipment should be non-sparking, adequately sealed or intrinsically safe. If any hot work is to be conducted on the refrigeration equipment or any associated parts, appropriate fire extinguishing equipment should be available to hand. Have a dry powder or CO2 fire extinguisher adjacent to the charging area.

No person carrying out work in relation to a refrigeration system which may expose any pipe that contains or has contained flammable refrigerant should use any sources of ignition in such a manner that it may lead to the risk of fires or explosions.

All possible ignition sources, including lighted cigarettes, should be kept sufficiently far away from the site of installation, repair, removal and disposal, during which flammable refrigerant can possibly be released into the surrounding space.

Prior to work, the area around the equipment should be checked to make sure that there are no flammable hazards or ignition risks. "No Smoking" signs should be displayed.

Ensure that the area is in the open or adequately ventilated before breaking into the system or conducting any hot work. A degree of ventilation should continue during the work. The ventilation should safely disperse any released refrigerant and preferably expel it externally into the atmosphere.

For any change of the electrical components, they should be fit for the intended purpose and comply with the correct specifications.

Always follow the manufacturer's maintenance and service guidelines. In case of any doubt, consult the manufacturer's technical department for assistance.

The following checks should be applied to installations using flammable refrigerants:

- The charge size should depend on the size of the room within which refrigerant containing components are installed;

- The ventilation machinery and outlets should operate adequately and not be obstructed;

- If an indirect refrigerating circuit is used, the secondary circuit should be checked for any refrigerant;

- Marking to the equipment should remain visible and legible. Illegible markings and signs should be corrected;

- Refrigeration pipes or components should be installed in positions where they are unlikely to be exposed to any substance which may corrode refrigerant containing components, unless the components are constructed of materials that are inherently resistant to corrosion or are suitably protected against corrosion.

Repair and maintenance of electrical components should include initial safety checks and component inspection procedures.

In the event of a fault that could compromise safety, no power supply should be connected to the circuit until it is satisfactorily dealt with. If the fault cannot be corrected immediately but it is necessary to continue operation, an adequate temporary solution should be used. This should be reported to the owner of the equipment to give advises to all parties involved.

Initial safety checks should include the following:

- Capacitors should be discharged in a safe manner to avoid possibility of sparking;

- No live electrical components and wiring should be exposed while charging, recovering or purging the system;

- The earth bonding should be continuous.

During repairs of sealed components, all power supplies should be disconnected from the equipment where work is in progress prior to any removal of sealed covers or other components. If it is absolutely necessary to keep a power supply connected with the equipment during servicing, a permanent leak detection should be performed at the most critical point to avoid a potential hazard.

Particular attention should be paid to the following to ensure that the casing is not altered in such a way that the level of protection is affected by working on electrical components. This includes damage to cables, an excessive number of connections, terminals not compliance with original specifications, damage to seals, and incorrect fitting of glands.

Ensure that seals or sealing materials have not degraded in such a manner that they no longer serve for the purpose of preventing the ingress of flammable atmospheres. Parts for replacement should be in accordance with the manufacturer's specifications.

Do not apply any permanent inductive or capacitance loads that exceed the permissible voltage or current of the equipment in use to the circuit.

Intrinsically safe components are the only types that can be worked on while live in the presence of a

flammable atmosphere. The test apparatus should be provided with the correct rating.

Replace components only with parts specified by the manufacturer. Other parts may result in the ignition of refrigerant in the atmosphere due to a leak.

Check and ensure that cabling is free from wear, corrosion, excessive pressure, vibration, sharp edges or any other adverse environmental effects. The check should also take into account the effects of ageing or continual vibration from sources such as compressors or fans.

When breaking into the refrigerant circuit for repair – or for any other purpose – follow the conventional procedures. However, it is important to follow the best practice.

Since flammability is a consideration, the following procedure should be adhered to:

- Remove the refrigerant;
- Purge the circuit with inert gas;
- Evacuate;
- Purge the circuit again with inert gas;
- Open the circuit by cutting or brazing.

The refrigerant should be recovered into correct recovery cylinders. The system should be “flushed” with OFN to guarantee the unit safety. This process may need to be repeated several times. Compressed air or oxygen should not be used for this task. Flushing should be achieved by breaking the vacuum in the system with OFN and continuing to fill until the working pressure is achieved before venting to the atmosphere and pulling down to a vacuum. This process should be repeated until no refrigerant exists in the system. When the final OFN charge is used, the system should be vented down to the atmospheric pressure so that the work can start.

This operation is absolutely vital if brazing operations on the pipe-work are to take place.

Ensure that the outlet for the vacuum pump is not close to any ignition sources and adequate ventilation is available.

Ensure that contamination of different refrigerants does not occur when using charging equipment. Hoses or lines should be as short as possible to minimize the amount of refrigerant contained in them.

Prior to recharging the system, it should be pressure tested with OFN.

#### Decommissioning:

Before this procedure starts, it is necessary for the technician to be completely familiar with the equipment and all its details. It is recommended that all refrigerants be recovered safely. Prior to the task, an oil and refrigerant sample should be taken in case analysis is required prior to re-use of reclaimed refrigerant.

It is essential that electrical power is available before the task is commenced.

- a) Be familiar with the equipment and its operation.
- b) Isolate the system electrically.
- c) Before attempting the procedure, ensure

that:

- Mechanical handling equipment is available, if required, for handling refrigerant cylinders;

- All personal protective equipment is available and being used correctly;

- The recovery process is supervised at all times by a competent person;

- The recovery equipment and cylinders should conform to the appropriate standards.

- d) Pump down refrigerant system, if possible.

- e) If a vacuum is not possible, make a manifold so that refrigerant can be removed from various parts of the system.

- f) Make sure that the cylinders are situated on the scales before recovery.

- g) Start the recovery machine and operate it in accordance with manufacturer's instructions.

- h) Do not overfill the cylinders. (No more than 80 % of volume for liquid charge).

- i) Do not exceed the maximum working pressure of the cylinders, even temporarily.

- j) When the cylinders have been filled correctly, make sure that the cylinders and the equipment are removed from the site promptly and all isolation valves on the equipment are closed off.

- k) Recovered refrigerant should not be charged into another refrigeration system unless it has been cleaned and checked.

Equipment should be labeled stating that it has been de-commissioned and emptied of refrigerant. The label should be dated and signed. Ensure that the equipment is provided with a label stating the existence of flammable refrigerant in the equipment. When removing refrigerant from a system, either for servicing or decommissioning, it is recommended that all refrigerants be removed safely. Always transfer refrigerant into appropriate cylinders. Ensure that a correct number of cylinders are available for supporting the total system charge. All cylinders to be used should be designated for the recovered refrigerant and labeled for that refrigerant (i.e. special cylinders for the recovery of refrigerant). The cylinders should be complete with pressure relief valves and associated shut-off valves in good working conditions. Empty recovery cylinders should be evacuated and, if possible, cooled down before recovery occurs.

The recovery equipment should be in good working conditions with a set of instructions concerning the equipment that is at hand and should be suitable for the recovery of flammable refrigerants. In addition, a set of calibrated weighing scales should be available and work properly. Hoses should be complete with leak-free disconnect couplings and work properly.

Before using the recovery machine, check and ensure that it is in satisfactory working conditions and has been properly maintained, and that all associated electrical components are sealed to prevent ignition in the event of a refrigerant leak.

Consult the manufacturer if in in case of any doubt.

The recovered refrigerant should be returned to the refrigerant supplier in correct recovery cylinders, with the relevant Waste Transfer Note arranged. Do not mix refrigerants in recovery units and especially not in cylinders. If any compressor or compressor oils is to be removed, ensure that it has been evacuated to an acceptable level to ensure that flammable refrigerant does not remain within the lubricant. The evacuation process should be carried out prior to returning the compressor to the supplier. To accelerate this process, you can only heat the compressor body with an electric heater. Draining oil from the system should ensure the safety.

Warning: Disconnect the appliance from its power source during servicing and parts replacement.

These units are partial unit air conditioners, complying with partial unit requirements of this International Standard, and must only be connected to other units that have been confirmed as complying to corresponding partial unit requirements of this International Standard.

Ask the installer to tell you how to make the following settings:

- on/off
- modification of setpoints
- put to rest
- maintenance
- what to do/not to do in the event of a breakdown .

## 1.10.Leak detection

The following leak detection methods are deemed acceptable for systems containing flammable refrigerants. Electronic leak detectors should be used to detect flammable refrigerants, but the sensitivity may not be adequate, or may need re-calibration. (Detection equipment should be calibrated in a refrigerant-free area.) Ensure that the detector is not a potential source of ignition and is suitable for the refrigerant. Leak detection equipment should be set at a percentage of the LFL of the refrigerant and should be calibrated to be suitable for the refrigerant employed, with the appropriate percentage of gas (25% maximum) confirmed. Leak detection fluids should be suitable for most refrigerants but the use of detergents containing chlorine should be avoided as the chlorine may react with the refrigerant and corrode the copper pipes. If a leak is suspected, all naked flames should be removed or extinguished. If a leakage of refrigerant is found and brazing is required, all of the refrigerant should be recovered from the system, or isolated (by means of shut off valves) in a part of the system that is far from the leak. The system should be purged with oxygen free nitrogen (OFN) both before and during the brazing process.

## 1.11.Disposal

This equipment uses flammable refrigerants. The disposal of the equipment must comply with national regulations. Do not dispose this product as unsorted municipal waste. Collection of such waste separately for special treatment is necessary.

- Do not dispose of electrical appliances as unsorted municipal waste, and use separate collection facilities.
- Contact your local government for information regarding the collection systems available.

If electrical appliances are disposed of in landfills or dumps, hazardous substances can leak into the groundwater and get into the food chain, damaging your health and well-being.

## 2. INTRODUCTION

### 2.1. Validity of the instructions







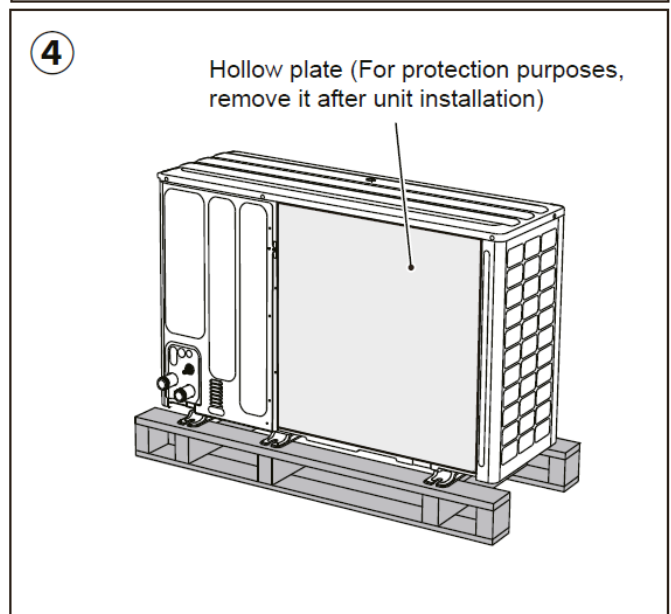
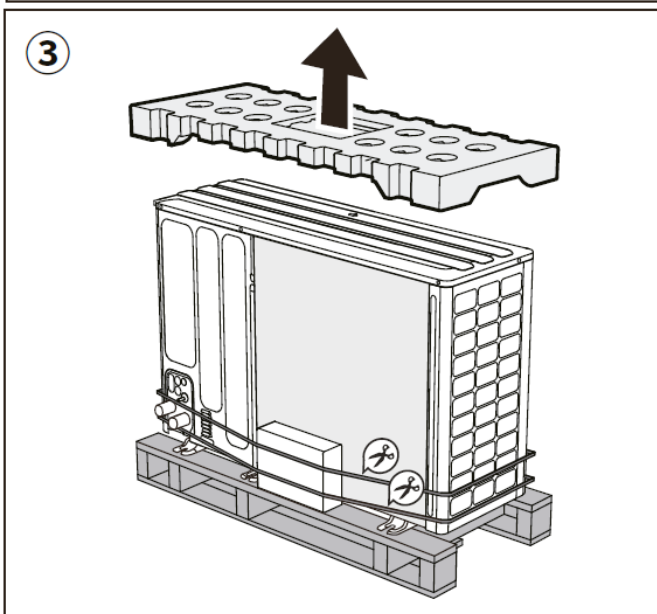
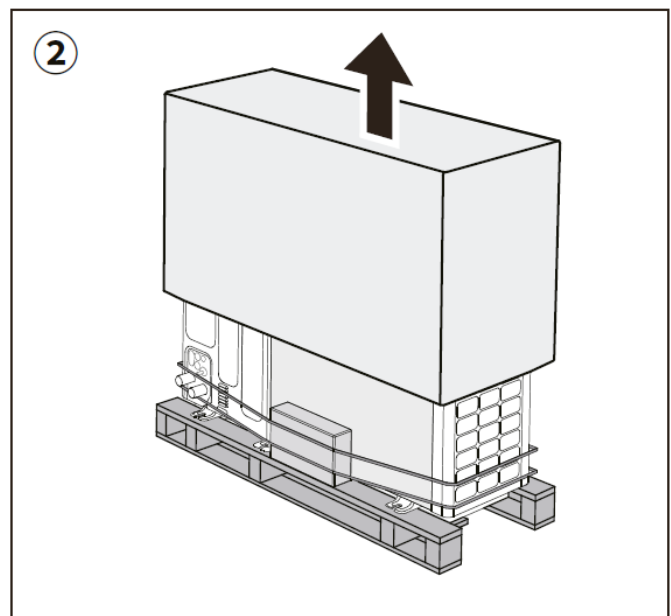
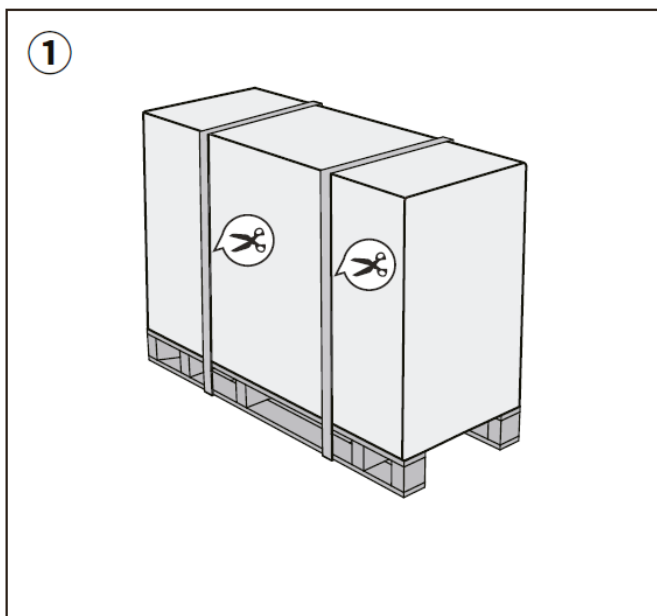





These instructions apply only to:

Unit	1 phase						3 phases		
	4	6	8	10	12	14	16	12	14
Net weight (kg)	95		122		140		142		
Wiring power supply (mm <sup>2</sup> )	3G2.5		3G4		3G6		5G2.5		
Mini flow rate (l/min)	7			12			12		
Backup heater (kW)	3						9 (3/6/9)		
Wiring back up heater power supply (mm <sup>2</sup> )	3G2.5						5G2.5		

### 2.2. Unpacking



## 2.3. Accessories of the unit

Accessories of the unit			
Name	Illustration	Quantity	Specification
Installation Manual (this manual)		1	
Operation Manual		1	
Y-shape strainer		1	4-6 kW : G1" 8-16kW : G1 1"1/4
Wired controller box		1	
Thermistor (DHW tank, zone 2 water flow or balance tank)		1	10m
Drain joint		1	Ø32
Energy label		1	
Tie wrap		4	
Corner protector		1	A
		1	B
Network matching line		1	
Extension wire for T5 or T1B		1	



## 2.4. Transportation

### 2.4.1. Dimensions and barycenter

The illustrations below are for 8-16 kW units. The principle is the same for 4-6 kW units. A, B, and C indicate the locations of barycenter.

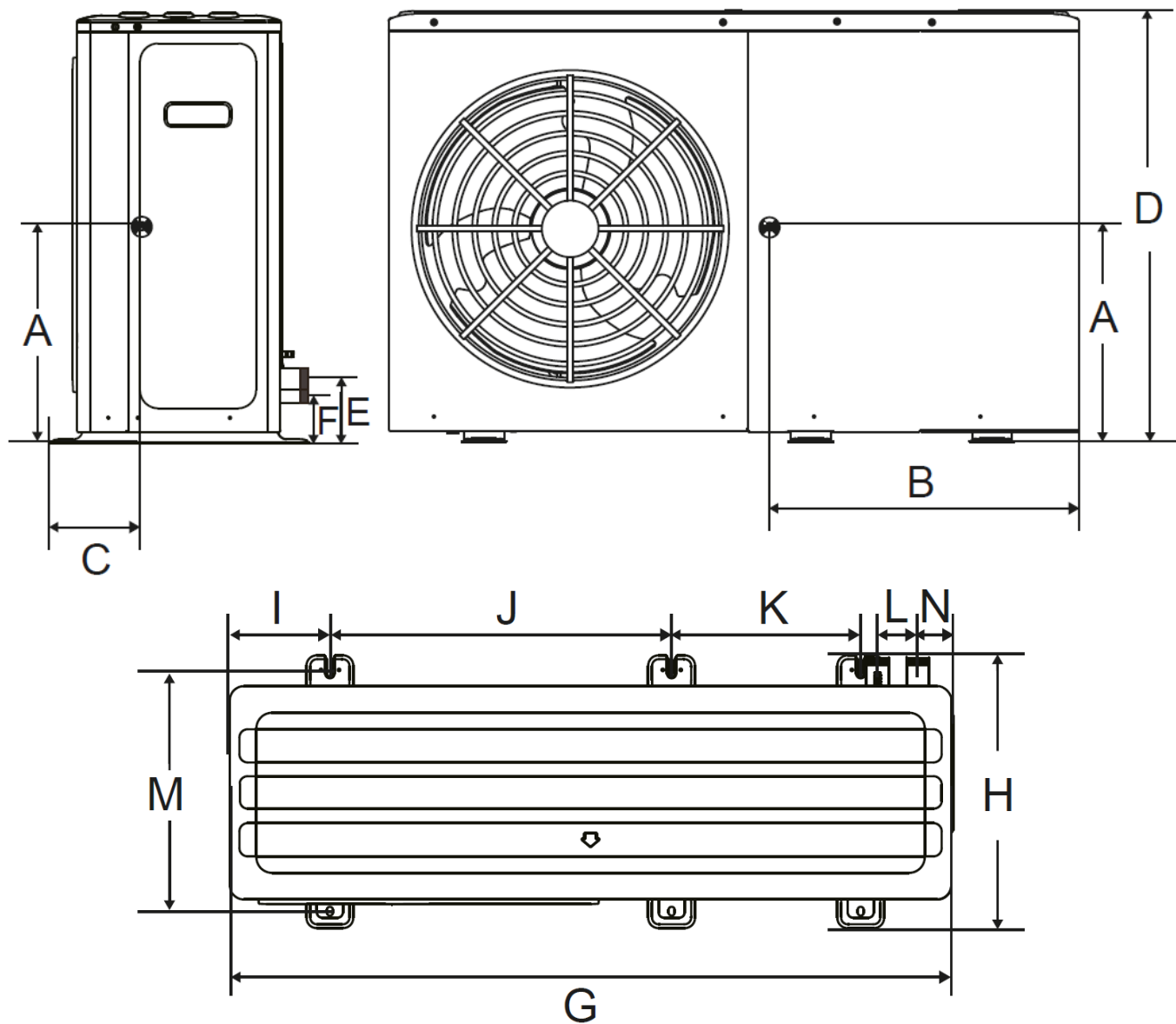

Models	A	B	C	D	E	F	G	H	I	J	K	L	M	N
4-6 kW	333	528	210	717	91	91	1299	426	121	644	379	90	375	71
8-10 kW	360	550	234	865	129	100	1385	523	192	656	363	77	456	68
1ph 12-14-16 kW	415	715	200	865	129	100	1385	523	192	656	363	77	456	68
3ph 12-14-16 kW	415	715	200	865	129	100	1385	523	192	656	363	77	456	68

## 2.4.2. Manual transportation

### **WARNIG**

*Risk of injury from lifting a heavy weight. Lifting weights that are too heavy may cause injury to the spine, for example.*

- Note the weight of the product.
- Have four people lift the product.

1.Take into consideration the weight distribution during transportation. The product is significantly heavier on the compressor side than on the fan motor side. (see content above for the barycenter)

2.Protect the casing sections from damage. Using corner protectors under the unit when lift the unit.

3.After transportation, remove the transport straps.

4.During transportation, do not tilt the product to an angle larger than 45°.

## 2.4.3. Lifting

Use lifting tools with transport straps or a suitable hand truck. Unit on the pallet:

Pass the transport straps through the holes on the left and right sides of the pallet properly.

No pallet under the unit:

The transport straps can be fitted into foreseen sleeves at the base frame that are made specifically for this purpose. Using corner protectors under the unit when lifting the unit.

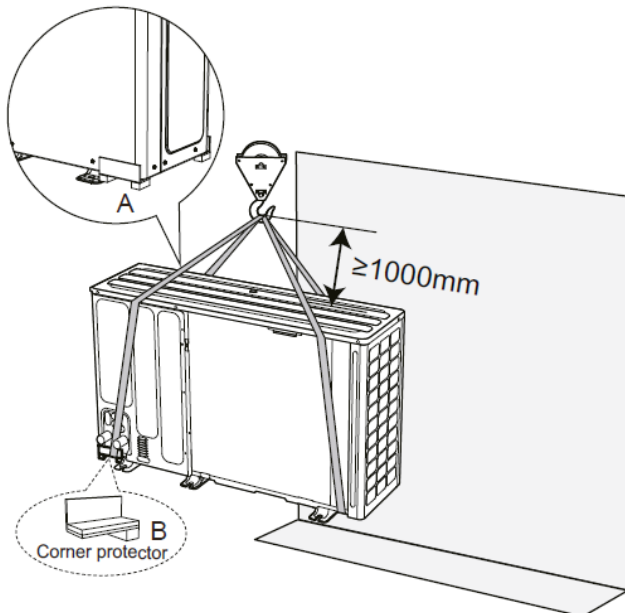

### **NOTE**

*The barycenter of the product and the hook should be kept in a straight line in the vertical direction to prevent excessive tilting.*

## 2.5. Parts to be Removed

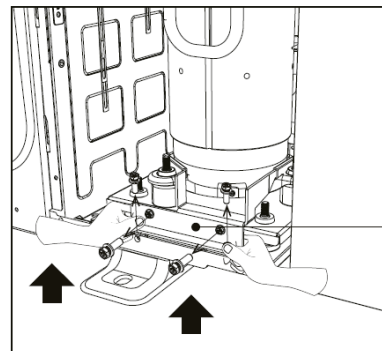
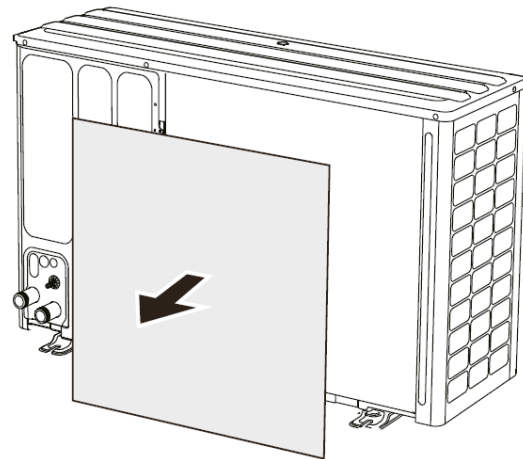

Remove the transportation support

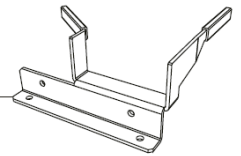

For 3-phase 12/14/16kW

### **CAUTION**

*Move the parts above after unit installation.*

## 2.6. Operating range

In cooling mode, the product works at an outdoor temperature of -5 to 46°C.

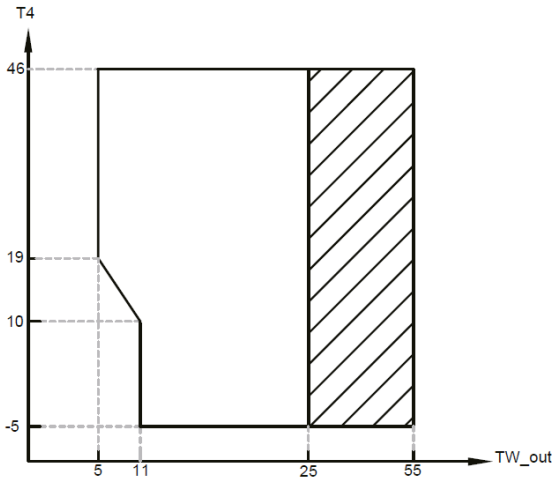



 Operation range by heat pump with possible limitation and protection.

TW\_out leaving water temperature  
T4 outdoor ambient temperature

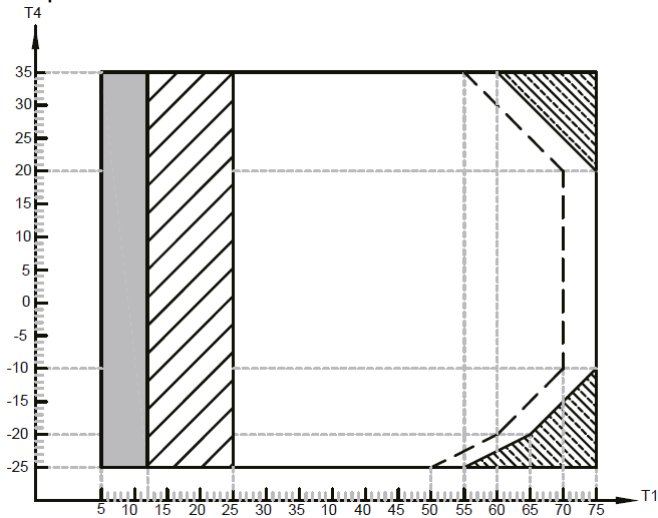
In heating mode, the product works at an outdoor temperature of -25 to 35°C.



 If IBH/AHS setting is valid, only IBH/AHS turns on;  
If IBH/AHS setting is invalid, only heat pump turns on, limitation and protection may occur during heat pump operation.

 Operation range by heat pump with possible limitation and protection.

 Heat pump turns off, only IBH/AHS turns on.

 Maximum inlet water temperature line for heat pump operation.

T1 leaving water temperature  
T4 outdoor ambient temperature

In DHW mode, the product works at an outdoor temperature of -25 to 46°C.

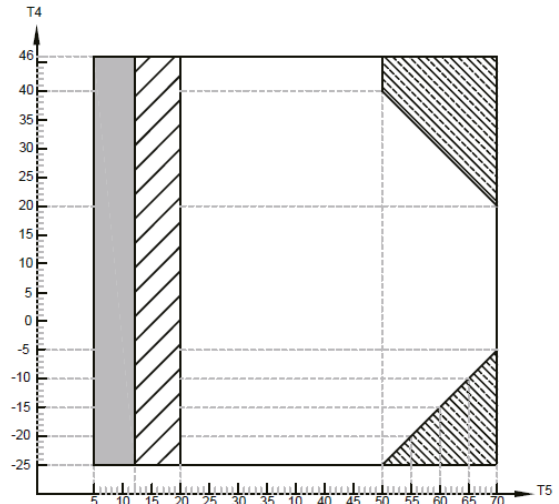



 If TBH/IBH/AHS setting is valid, only TBH/IBH/AHS turns on;  
If TBH/IBH/AHS setting is invalid, only heat pump turns on, limitation and protection may occur during heat pump operation.

 Operation range by heat pump with possible limitation and protection.

 Heat pump turns off, only TBH/IBH/AHS turns on.

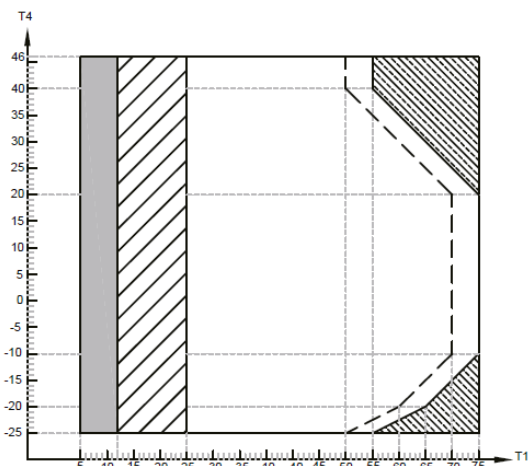
T5 DHW tank temperature  
T4 outdoor ambient temperature



 If IBH/AHS setting is valid, only IBH/AHS turns on;  
If IBH/AHS setting is invalid, only heat pump turns on, limitation and protection may occur during heat pump operation.

 Operation range by heat pump with possible limitation and protection.

 Heat pump turns off, only IBH/AHS turns on.

 Maximum inlet water temperature line for heat pump operation.

T1 leaving water temperature  
T4 outdoor ambient temperature

## 2.7. Hydraulic Module

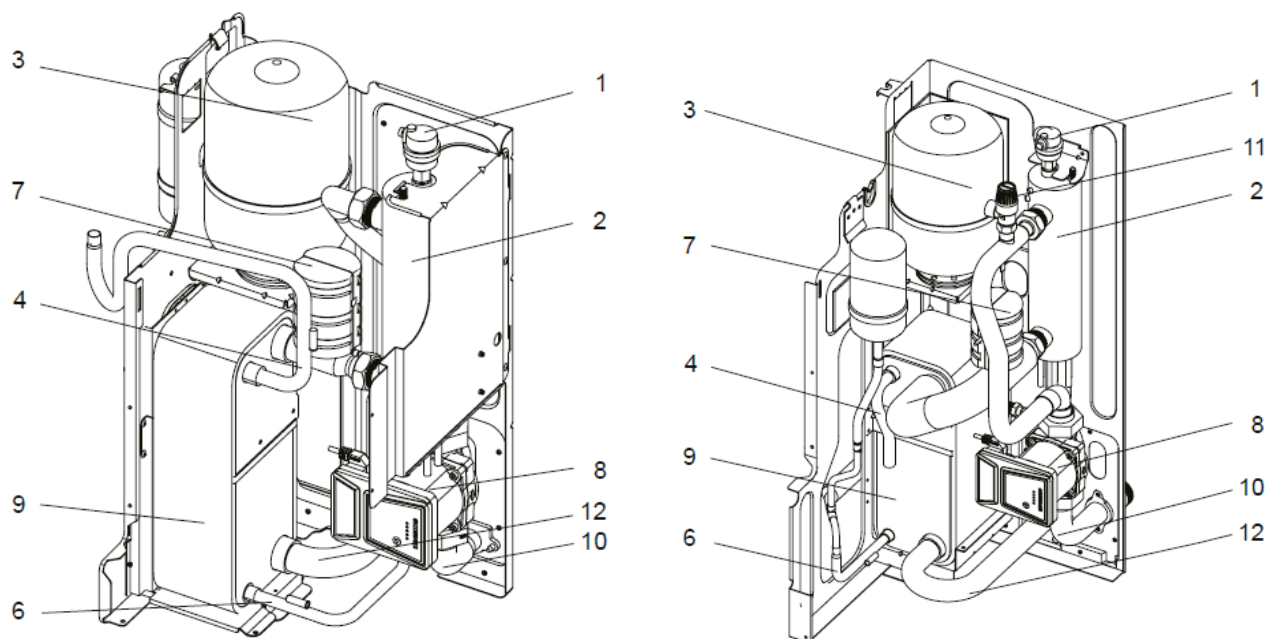

4-6kW8-16kW

Code	Assembly unit	Explanation
1	Automatic air purge valve	Automatically removes the remaining air from the water loop.
2	Backup heater	Provides additional heating capacities when the heating capacity of the heat pump is insufficient due to low outdoor temperature, and protects the external water pipes from freezing.
3	Expansion vessel	Balances the water system's pressure.
4	Refrigerant gas pipe	/
5	Temperature sensor	Four temperature sensors determine the water and refrigerant temperature at various points in the water loop: 5.1-T2B, 5.2-T2, 5.3-T1, 5.4-TW_out, and 5.5-TW_in
6	Refrigerant liquid pipe	/
7	Flow switch	Detects the water flow rate to protect the compressor and water pump in the event of insufficient water flow.
8	Pump	Circulates water in the water loop.
9	Plate heat exchanger	Transfers heat from the refrigerant to the water.
10	Water outlet pipe	/
11	Pressure relief valve	Prevents excessive water pressure by opening when the pressure reaches 3 bar and discharging water from the water loop.
12	Water inlet pipe	/

## 3. SAFETY ZONE

The refrigerant circuit in the outdoor unit contains easily flammable refrigerant in safety group A3 as described in ISO 817 and ANSI/ASHRAE Standard 34. Therefore, a safety zone is defined in the immediate vicinity of the outdoor unit, in which special requirements apply. Note that this refrigerant has a higher density than air. In the event of a leak, escaping refrigerant may be collected near the earth.

The following conditions must be avoided within the safety zone:

- Building openings such as windows, doors, light wells, and flat roof windows;
- Outdoor air and exhaust air apertures of ventilation and air conditioning systems;
- Property boundaries, neighboring properties, footpaths, and driveways;
- Pump shafts, inlets to waste water systems, downpipes, and waste water shafts, etc.;
- Other slopes, troughs, depressions, and shafts;
- Electrical house supply connections;
- Electrical systems, sockets, lamps, and light switches; Snowfall from roofs.

Do not introduce ignition sources into the safety zone:

- Naked flames or burner gauze assemblies.
- Grills.
- Tools that generate sparks.
- Electrical devices not free of ignition sources, mobile devices with integrated batteries (such as mobile phones and fitness watches).
- Objects with a temperature of above 360°C.

### NOTE

The particular safety zone is dependent on the surroundings of the outdoor unit.

The safety zones below are shown with floor standing installation. These safety zones also apply to other types of installation.

Freestanding positioning of the outdoor unit

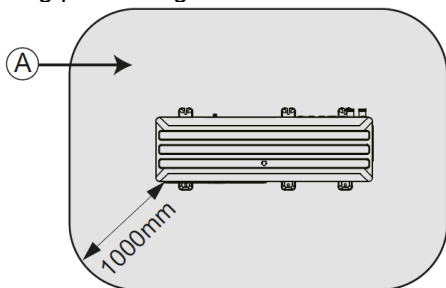

### Ⓐ Safety zone

Siting the outdoor unit in front of an external wall

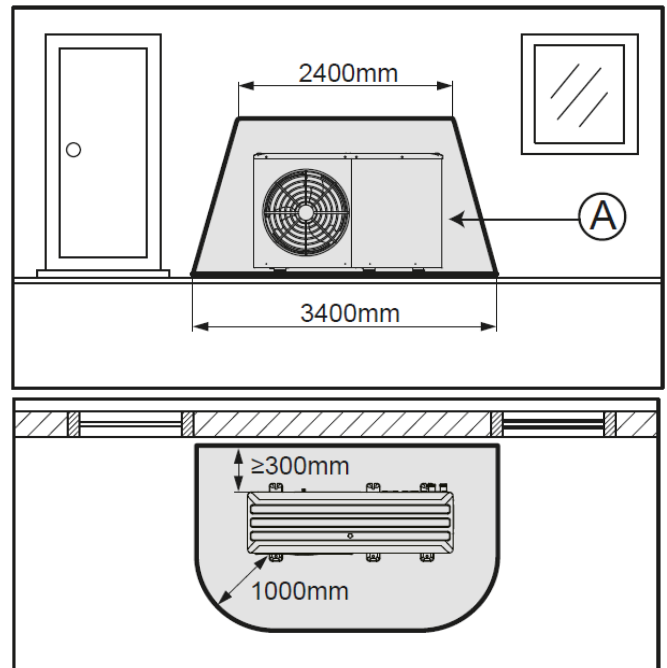

### Ⓐ Safety zone

Corner positioning of the outdoor unit, left

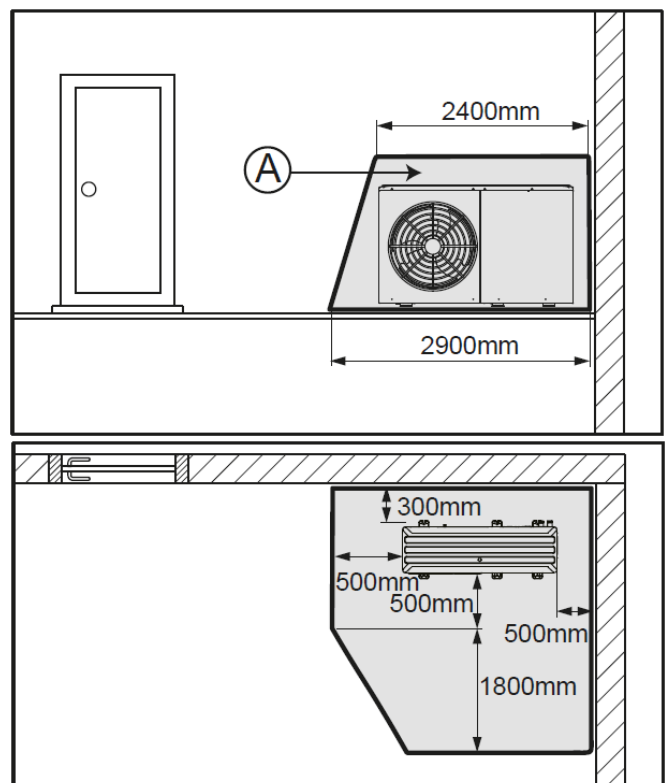

## 4. INSTALLATION

### 4.1. Conditions for Installation

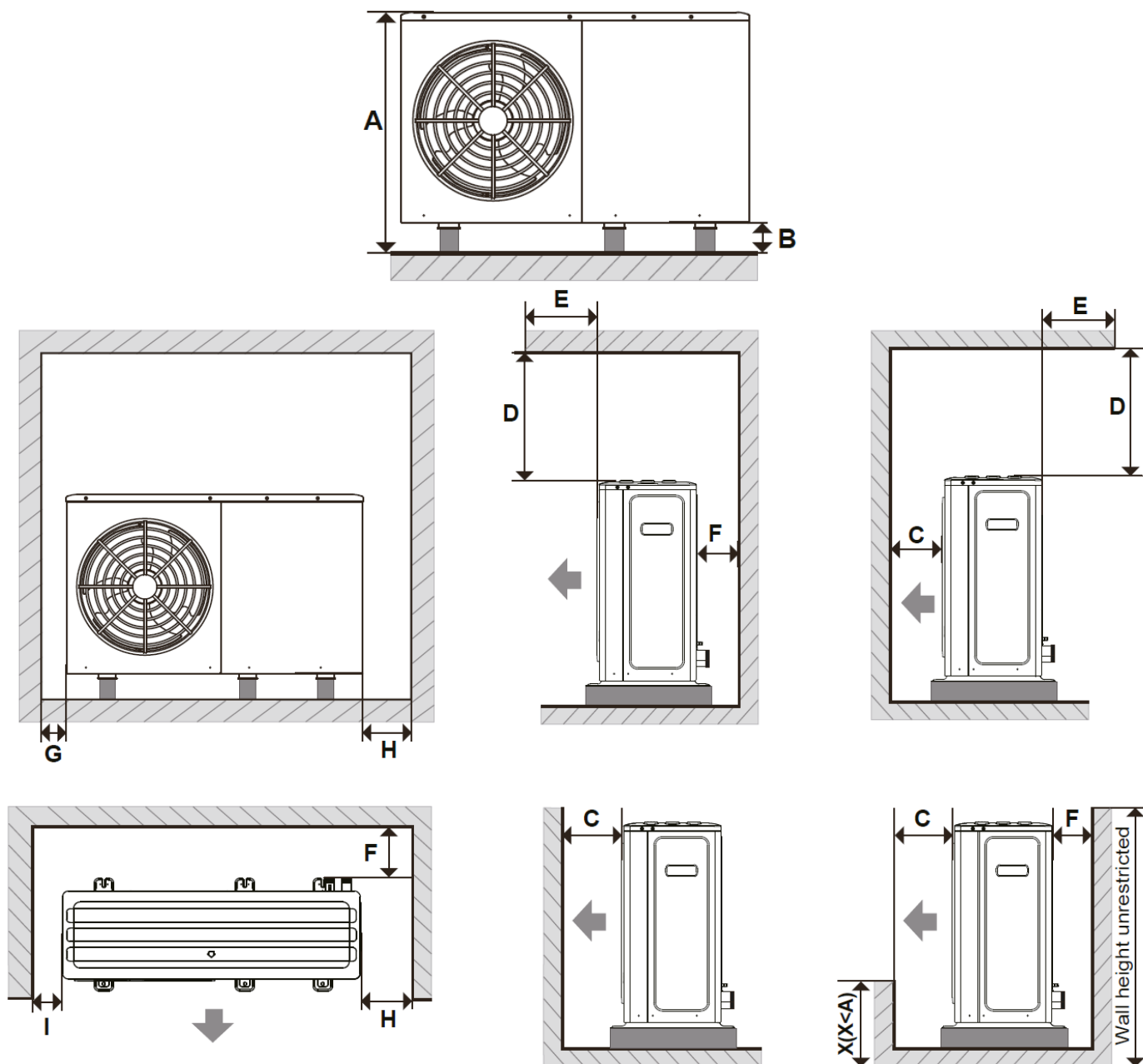

Models	A	B	C	D	E	F	G	H	I
4-10kW	Unit height + B	≥100*	≥1000	≥500	≥500	≥300	≥500	≥500	≥500
12-16kW	Unit height + B	≥100*	≥1500	≥500	≥500	≥300	≥500	≥500	≥500

\* In case of cold weather, take into account of snow on the ground. For more information, refer to 4.4 In Cold Climates.

In addition to “Safety zone”, the following conditions should be observed.

## Environment

- For the sake of safety and unit performance, the installation site must be with sufficient air flow.
- For maintenance and service purposes, the installation site should be highly accessible.
- Impact protection measures should be taken, if the installation site has high impact risks, such as a vehicle shunting area.
- Keep the unit away from flammable substances or flammable gases.
- Keep the unit away from heat sources.
- Keep the unit as far away from raindrops as possible.
- Do not expose the outdoor unit to any dirty, dusty or corrosive atmosphere.
- Keep the unit away from ventilation openings or ventilation ducts.

## Nature

Beware of the impact from the nature:

- Plants with vines could block the air inlet and outlet of the unit as they grow.
- Fallen leaves could block the unit air inlet or stuck the air channel.
- Insects, snakes or some small animals might enter the unit. Wild animals might bite or damage the piping and wiring of the unit.

### NOTE

*In case of any evidence of animal effects, ask professionals for inspection and maintenance.*

## Strong wind

When installing the unit in a place exposed to strong wind, pay special attention to the following:  
A wind speed of 5 m/s or higher against the unit's air outlet could cause a short circuit (suction of discharge air), which may have the following consequences:

- Deterioration of the operational capacity.
- Frequent frosting in heating operation.
- Disruption of operation due to pressure rise.
- When strong wind blows continuously on the front of the unit, the propeller could start rotating very fast until it breaks.

## Noise impact

Select an installation site that is as far away from living rooms and bedrooms as possible.  
Please note the noise emissions. Select an installation site that is as far away from the windows of adjacent buildings as possible.

## Installation by the sea

If the installation site is in the immediate vicinity of a coastline, ensure that the product is protected against spraying water by an additional protection device.  
Wind from the sea brings saline substances to the land. This could have negative impacts on the unit due to long-time exposure to the saline substances. To prolong the lifetime of the unit, ask professionals for a customized maintenance proposal, and follow the proposal.

## Altitude

The unit is designed to be used below 2000 m of altitude. If it is installed above this level, its performance and reliability cannot be guaranteed.

## 4.2. Installation Site

The product is suitable for installation on a ground, wall or flat roof.

### NOTE

*Installation on a pitched roof (inclined place) is not permitted.*

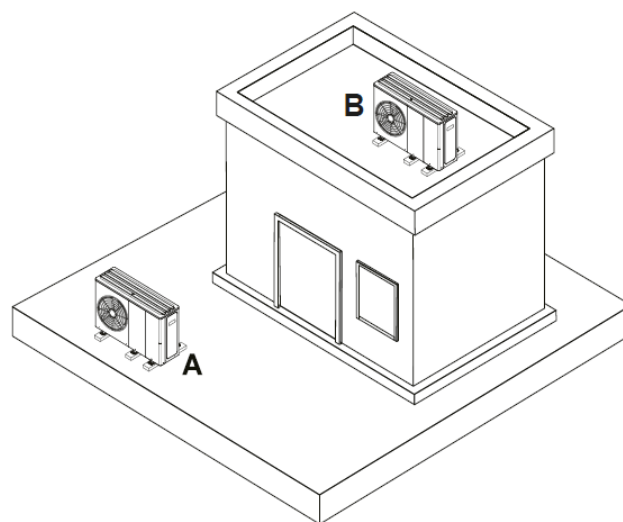

- (A) Installation on a ground
- (B) Installation on a flat roof

## 4.2.1. Precautions for installation on a ground

- Avoid any installation site that is in the corner of a room, between walls or between fences.
- Prevent the return intake of air from the air outlet.
- Ensure that water cannot accumulate on the subsoil.
- Ensure that the subsoil can absorb water well.
- Plan a bed of gravel and rubble for the condensate discharge.
- Select an installation site that is free from significant accumulations of snow in winter.
- Select an installation site at which the air inlet is not affected by strong wind. Position the unit crosswise to the wind direction whenever it is possible.
- If the installation site is not protected against wind, a protective wall is required.
- Please note the noise emissions. Avoid corners of rooms, recesses or sites between walls.
- Select an installation site with excellent sound absorption performance such as those with grass, hedges or fencing.
- Route the hydraulic lines and electrical wires underground.
- Provide a safety pipe that leads from the outdoor unit through the wall of the building

## 4.2.2. Precautions for installation on a flat roof

- Only install the product in a building with a solid construction structure and that has cast concrete ceilings throughout.
- Do not install the product in any building with a wooden structure or with a lightweight roof.
- Select an installation site that is easily accessible so that foliage or snow can be regularly removed from the product.
- Select an installation site at which the air inlet is not affected by strong wind. Position the unit crosswise to the wind direction whenever it is possible.
- If the installation site is not protected against wind, a protective wall is required.
- Please note the noise emissions. Maintain a sufficient clearance from adjacent buildings.
- Route the hydraulic lines and electrical wires.
- Provide a wall duct.

## 4.2.3. Occupational safety

### Installation on a flat roof

- Ensure that the flat roof can be safely accessed.
- Maintain a safety area that is 2 m from falling edges, and a clearance that is required for working on the product. The safety area must be inaccessible.
- If this is not possible, install technical falling protections at the falling edges such as reliable railings. Alternatively, set up technical safety equipment such as scaffolding or safety nets.

- Maintain a sufficient clearance from any roof escape hatches and flat-roof windows. Use suitable protective equipment (e.g. barriers) to prevent people from stepping on or falling through any escape hatches and flat-roof windows.

## 4.3. Foundation and Unit Installation

### 4.3.1. Installation on a ground

#### Installation on a soft ground

In case of installation on a soft ground such as lawn and soil, create a foundation as shown in the figure below.

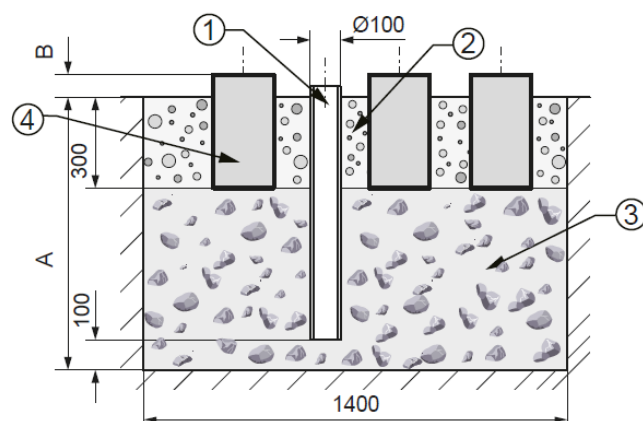

- 1) Downpipe for drainage
- 2) Strip foundations
- 3) Water-permeable coarse rubble
- 4) Concrete strip foundations

- Dig a hole in the ground. For the location of the downpipe, refer to 5.4.1 Drain hole position.
- Insert a downpipe (1) to divert the condensate.
- Add a layer of water-permeable coarse rubble (3).
- Calculate the depth (A) in accordance with local conditions.
  - Region with ground frost: minimum depth: 900 mm
  - Region without ground frost: minimum depth: 600 mm
- Calculate the height (B) in accordance with local conditions. Such height should not be smaller than 100 mm.
- Create three concrete strip foundations (4). The recommended dimensions can be found in the figure.
  - Make sure the three foundations are level.
  - There are no restrictions on the width or length of the foundations, provided that the unit can be mounted on the foundation properly and the downpipe for drainage is not blocked.
  - Add a gravel bed between and beside the strip foundations (2) to divert the condensate.



## Installation on a solid ground

In case of installation on a solid ground such as concrete, create a concrete strip foundation comparable to what is described in the section above. The height of the strip foundation should not be smaller than 100 mm.

### Unit mounting

Installation with foundation: Fix the unit with foundation bolts. (Six sets of  $\Phi 10$  expansion bolts, nuts and washers are needed, which are provided by the user). Screw the foundation bolts to a depth of 20 mm into the foundation.

Installation without foundation: Install proper anti-vibration pads and level the unit.

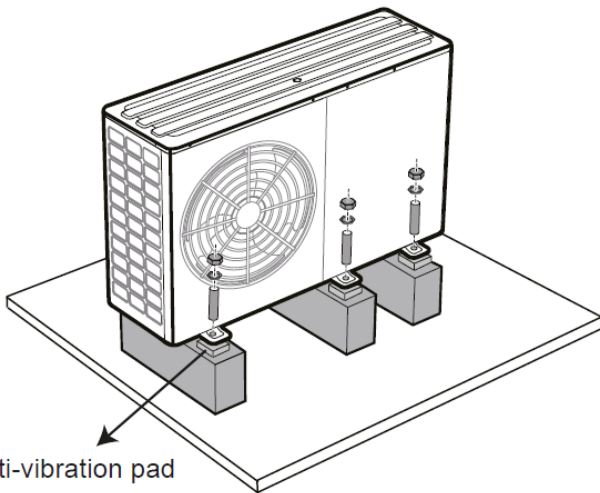

Anti-vibration pad

## 4.3.2. Installation on a flat roof

In case of installation on a flat roof, create a concrete strip foundation comparable to what is described in 5.3.1

Installation on a ground. The height of the strip foundation should not be smaller than 100 mm.

Take drainage layout into consideration, and install the unit close to the drainage.

### Unit mounting

Same as 5.3.1 Installation on a ground.

## 4.4. Drainage

### 4.4.1. Drain hole position

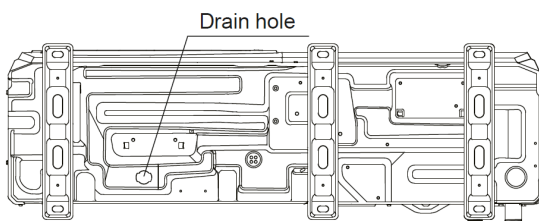

4/6 kW

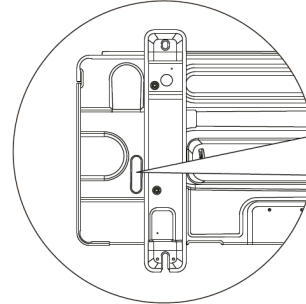
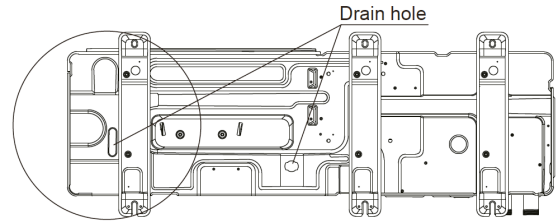

This drain hole is covered by a rubber plug. If the small drain hole cannot meet the drainage requirements, the big drain hole can be used instead.

8/10/12/14/16 kW

### CAUTION

- Watch the condensate when removing the rubber plug of the additional drain hole.
- Make sure the condensate is drained properly. Collect and direct the condensate that can drip from the base of the unit to a drain tray.
- Prevent water dripping onto the floor that may generate a slip hazard, especially in winter.
- For cold climate with high humidity, it is highly recommended that a bottom plate heater be installed to avoid damage to the unit due to the drain water freezing in case of a low drainage rate.
- Collect and direct the condensate that can drip from the base of the unit to a drain tray.
- Prevent water dripping onto the floor that may generate a slip hazard, especially in winter.

## 4.4.2. Drainage layout (installation on a ground)

### Drain joint

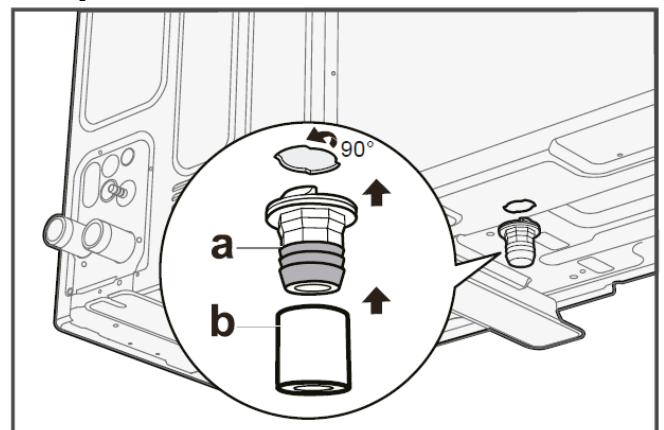

a – Drain joint (plastic, Pagoda connection, 1")

b - Drain hose (field supply)

## Installation on a soft ground

### Draining condensate into a gravel bed

For installation on a ground, the condensate must be discharged through a downpipe into a gravel bed that is located in a frost-free area.

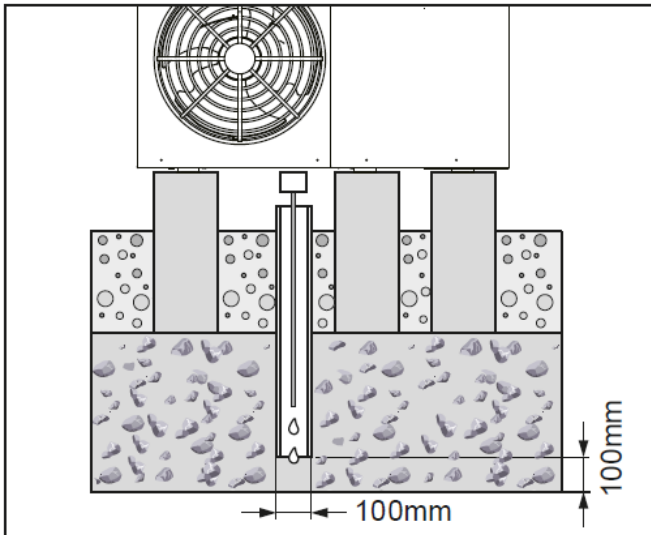

The downpipe must flow into a sufficiently large gravel bed so that the condensate can trickle away freely.

#### NOTE

To prevent the condensate from freezing, the heating wire must be threaded into the downpipe through the condensate discharge.

### Draining condensate through a pump sump/soakaway

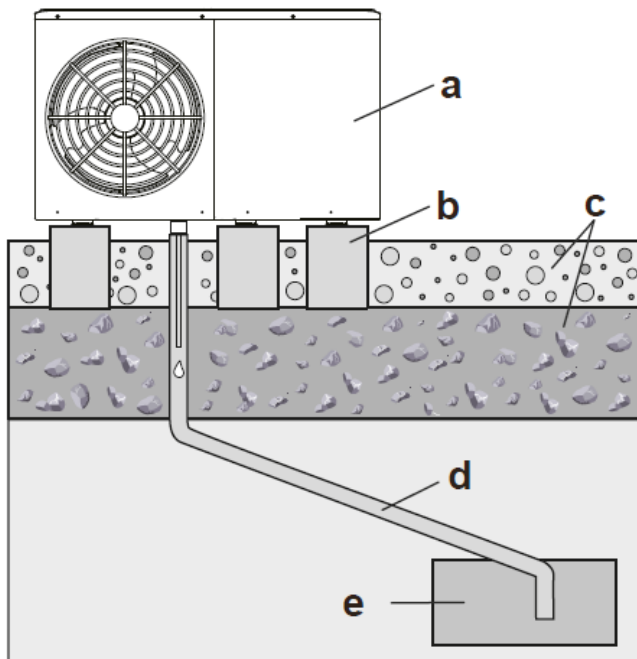

- a - Outdoor unit
- b - Concrete strip foundations
- c - Foundation (See 5.3.1 Installation on a ground)
- d - Drain pipe(at least DN 40)
- e - Pump sump/soakaway

## Sewer

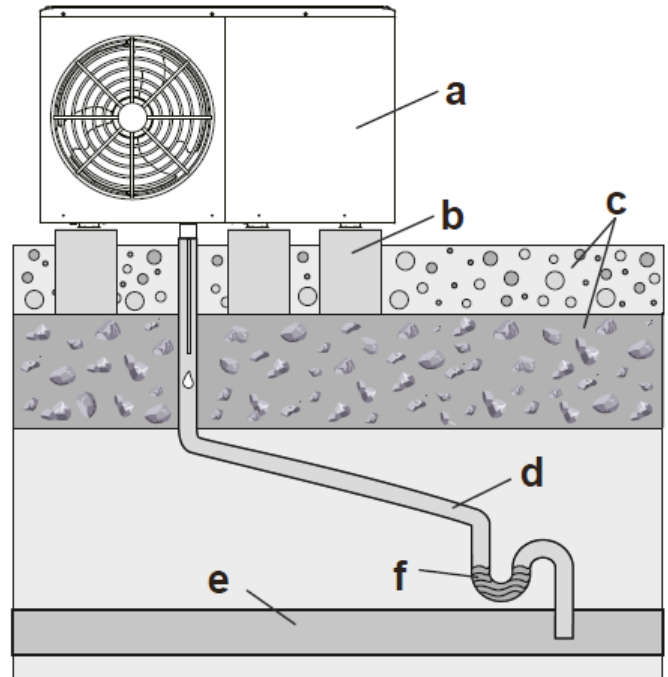

- a - Outdoor unit
- b - Concrete strip foundations
- c - Foundation (See 5.3.1 Installation on a ground)
- d - Drain pipe (at least DN 40)
- e - Sewer
- f - Stench trap in an area free from frosting risks

### Installation on a solid ground

Guide the condensation pipe to a sewer, pump sump or soakaway.

The drain plug in the accessory pack cannot bend to another direction. For this, use a hose to guide the condensate into a sewer, pump sump or soakaway through a gully, balcony run-off or roof run-off.

Open gullies within the safety zone do not pose any safety risk.

### Installation on a flat roof

Refer to Installation on a solid ground.

#### NOTE

For all installation types, ensure that any accumulated condensate is discharged in a frost-free manner.

To prevent the condensate from freezing, the heating tape can be threaded into the downpipe through the condensate discharge.

## 4.5. Cold Climates

It is recommended that the unit be placed with the rear side against the wall.

Install a lateral canopy on top of the unit to prevent lateral snowfall in extreme weather conditions.

Install a high pedestal or wall mount the unit to keep a proper clearance (at least 100 mm) between the unit and snow.

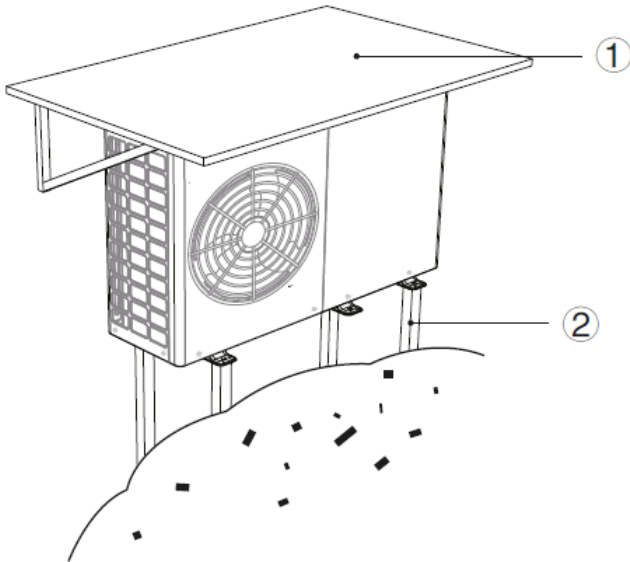

- ① Canopy or alike
- ② Pedestal in case of installation on a ground

## 4.6. Exposure to Strong Sunlight

Long time of exposure of the ambient temperature sensor of the unit to sunlight might impact the sensor negatively, and cause undesirable impacts on the unit. Shade the unit with a canopy or alike.

## 5. SYSTEM DESIGN

### 5.1. Capacity and Load Curve

Match the load with appropriate capacity of the unit based on the curve below.

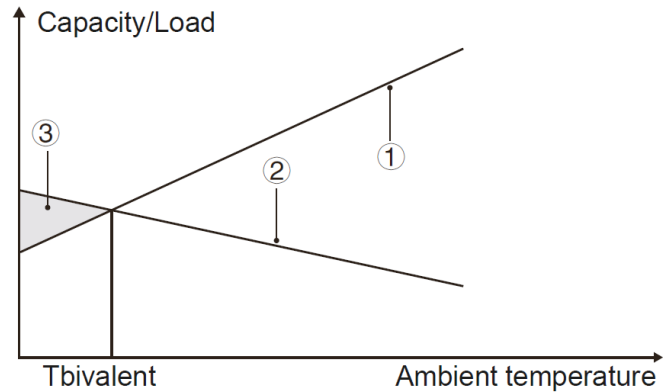

- ① Heat pump capacity
- ② Required heating capacity (site-dependent)
- ③ Additional heating capacity provided by backup heaters

For further details, consult with your supplier.

### 5.2. DHW Tank (Supplied by the User)

A domestic hot water (DHW) tank (with or without a booster heater) can be connected to the unit.

The requirements for the tank vary with the unit model and the heat exchanger material.

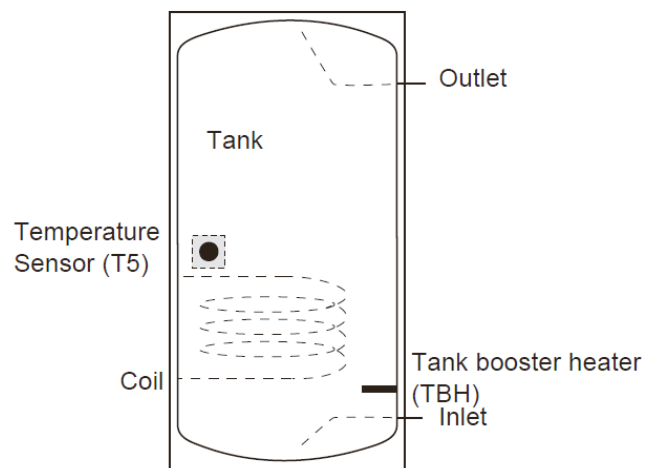

The booster heater should be installed below the temperature probe (T5).

The heat exchanger (coil) should be installed below the temperature probe.

Recommendation for the tank :

		4-6 kW	8-10 kW	12-16 kW
Tank volume	(L)	100-250	150-300	250-500
Stainless steel coil area	m <sup>2</sup>	1.4	1.4	1.6
Enamel coil area	m <sup>2</sup>	2.0	2.0	2.5

See 6.1.5 Requirements for third-party tanks for more information.

## 5.3. Room Thermostat (Supplied by the User)

The room thermostat can be connected to the unit, and it should be kept away from heating sources.

## 5.4. Solar Kit for DHW Tank (Supplied by the User)

An optional solar kit can be connected to the unit. The unit can be controlled by T<sub>solar</sub> or by the input signal. See 10.2.7 Other heat sources.

## 5.5. Balance Tank (Supplied by the User)

The installation of a balance tank in the system can effectively reduce the unit startup frequency, and achieve efficient defrosting and mitigate room temperature fluctuations. The recommended balance tank size is as follows:

No.	Model	Balance tank (L)
1	4-10kW	≥25
2	12-16kW	≥40
3	Cascade system	≥40*n

n: Quantity of outdoor units

## 5.6. Additional Expansion Vessel

When the capacity of the integrated expansion vessel is insufficient for the system due to high water volume, an additional expansion vessel (supplied by the user) is needed.

1) Calculation of the pre-pressure (P<sub>g</sub>) of the expansion vessel:

$$P_g = 0.3 + (H / 10) \text{ (bar)}$$

H - installation height difference

2) Calculation of the volume of the additional expansion vessel:

$$V_1 = 0.103 * (V_{\text{water}} - 72.8) / (3 - P_g)$$

V<sub>1</sub> – volume of the additional expansion vessel  
V<sub>water</sub> – system water volume

3) For different scenarios, follow the table below.

4) See 6.1.4 Pre-pressure adjustment of the expansion vessel for how to adjust the pre-pressure of the integrated expansion vessel.

Installation height difference*	Water volume ≤ 72.8L	Water volume > 72.8L
H ≤ 12m	Pre-pressure adjustment	1) Pre-pressure adjustment is not required. 2) Make sure the water volume is lower than the maximum allowable water volume (see 6.1.2 Maximum water volume).
H > 12m	1) Increase the pre-pressure, and follow the calculation of the pre-pressure above. 2) Make sure the water volume is lower than the maximum allowable water volume (see 6.1.2 Maximum water volume).	Due to the small size of the integrated expansion vessel, an additional expansion vessel is required. See the calculation of the volume of the additional expansion vessel above.

\* The installation height difference above refers to the height difference between the highest point of the water circuit and the outdoor unit's expansion tank. When the unit is located at the highest point of the system, this value is zero.

## NOTE

*It is recommended to install an expansion vessel for the tapping water side.*

### 5.7.Circulation Pump

The relationship between the external static pressure (ESP) and the water flow rate is shown as follows:

#### 4-6kW

ESP (kPa)	Flow rate (m <sup>3</sup> /h)
29.6	2.892
36.1	2.708
43.7	2.49
51.2	2.301
57.9	2.101
65.2	1.901
73.1	1.699
80.7	1.5
85.2	1.297
86.8	1.1
88	0.901
88.5	0.8
89.1	0.61
89.5	0.376

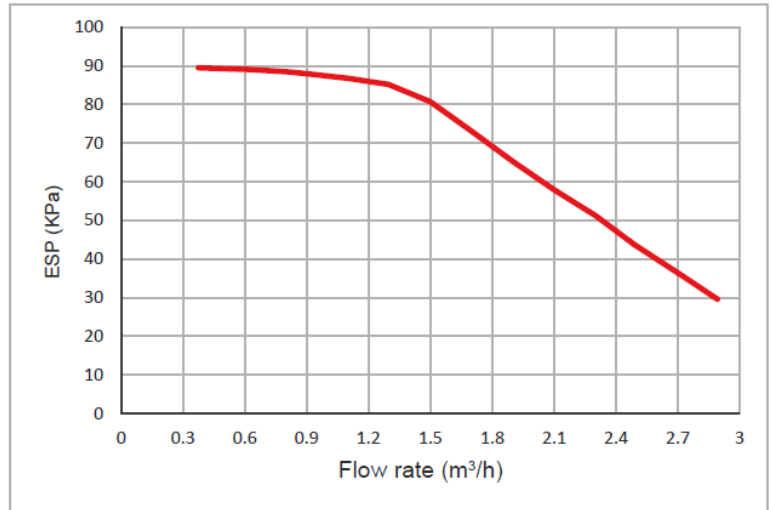

#### 8-10kW

ESP (kPa)	Flow rate (m <sup>3</sup> /h)
19.9	3.126
31.5	2.79
42.1	2.5
52.5	2.2
63	1.9
74.4	1.605
83.5	1.3
85.3	1
86.2	0.7
86.4	0.4

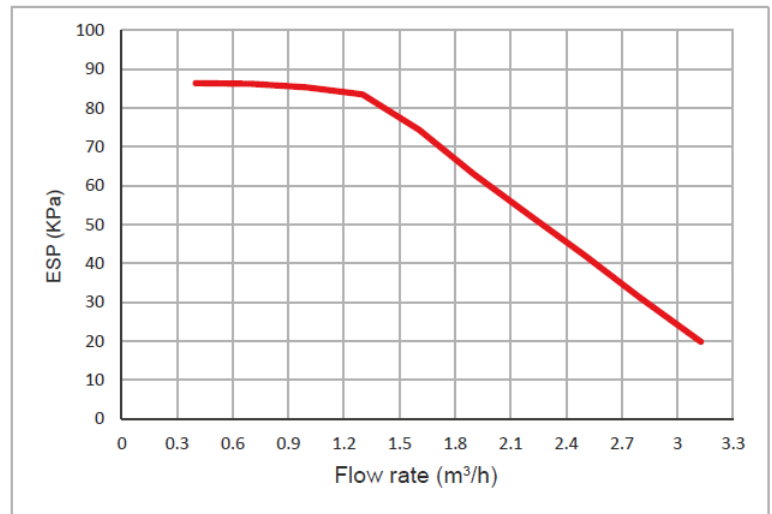

#### 12-16kW

ESP (kPa)	Flow rate (m <sup>3</sup> /h)
23.2	3.47
29.1	3.271
35.5	3.06
41	2.861
46.9	2.67
52	2.47
58	2.27
63.5	2.07
69.6	1.87
76.3	1.67
81.9	1.47
86.9	1.27
87.6	1.07
88.2	0.87
88.4	0.67

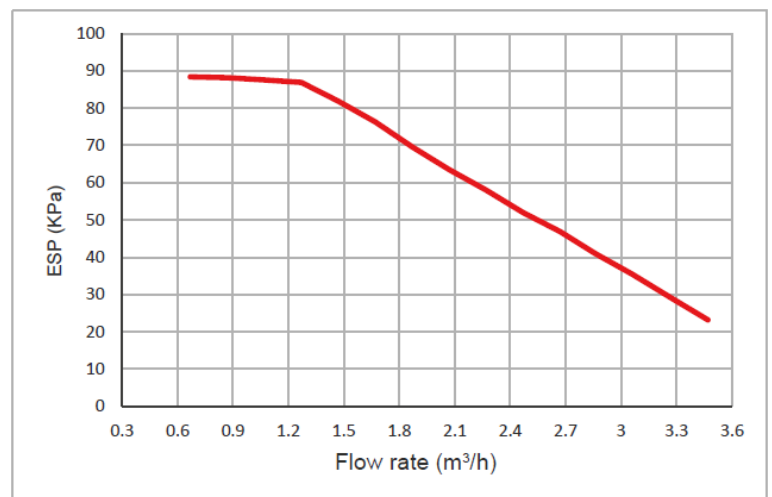

## CAUTION

*Installing the valves in wrong position can damage the circulation pump.*

## DANGER

*If it is necessary to check the running status of the pump with the unit powered on, please do not touch the internal electronic control box components to avoid electric shock.*

## 5.8. Thermistor

This table referring to the temperature sensor in the water loop side.

Temperature (°C)	Resistance (kΩ)	Temperature (°C)	Resistance (kΩ)	Temperature (°C)	Resistance (kΩ)
-10	269.569	30	39.427	70	8.547
-9	255.439	31	37.784	71	8.259
-8	242.131	32	36.219	72	7.983
-7	229.593	33	34.726	73	7.717
-6	217.774	34	33.304	74	7.461
-5	206.63	35	31.947	75	7.215
-4	196.119	36	30.653	76	6.978
-3	186.201	37	29.419	77	6.75
-2	176.84	38	28.241	78	6.531
-1	168.001	39	27.115	79	6.319
0	159.653	40	26.042	80	6.115
1	151.766	41	25.015	81	5.919
2	144.311	42	24.036	82	5.73
3	137.264	43	23.1	83	5.548
4	130.599	44	22.206	84	5.372
5	124.293	45	21.35	85	5.204
6	118.326	46	20.532	86	5.041
7	112.679	47	19.749	87	4.884
8	107.33	48	19.001	88	4.732
9	102.265	49	18.285	89	4.587
10	97.466	50	17.6	90	4.446
11	92.918	51	16.944	91	4.31
12	88.607	52	16.316	92	4.179
13	84.519	53	15.714	93	4.053
14	80.642	54	15.139	94	3.932
15	76.963	55	14.586	95	3.814
16	73.471	56	14.058	96	3.701
17	70.157	57	13.55	97	3.591
18	67.011	58	13.064	98	3.486
19	64.023	59	12.597	99	3.384
20	61.184	60	12.15	100	3.286
21	58.486	61	11.721	101	3.191
22	55.921	62	11.309	102	3.098
23	53.483	63	10.913	103	3.009
24	51.165	64	10.533	104	2.923
25	48.959	65	10.168	105	2.84
26	46.86	66	9.818	106	2.759
27	44.863	67	9.481	107	2.681
28	42.961	68	9.157	108	2.606
29	41.151	69	8.846	109	2.533
				110	2.463

## NOTE

*The resistance tolerance is 3% at 50°C and 5% at 25°C.*

## 6. TYPICAL INSTALLATIONS

The application examples given below are only for illustration purposes.

### 6.1. Controlled through the wired controller

#### 6.1.1. Single-zone control

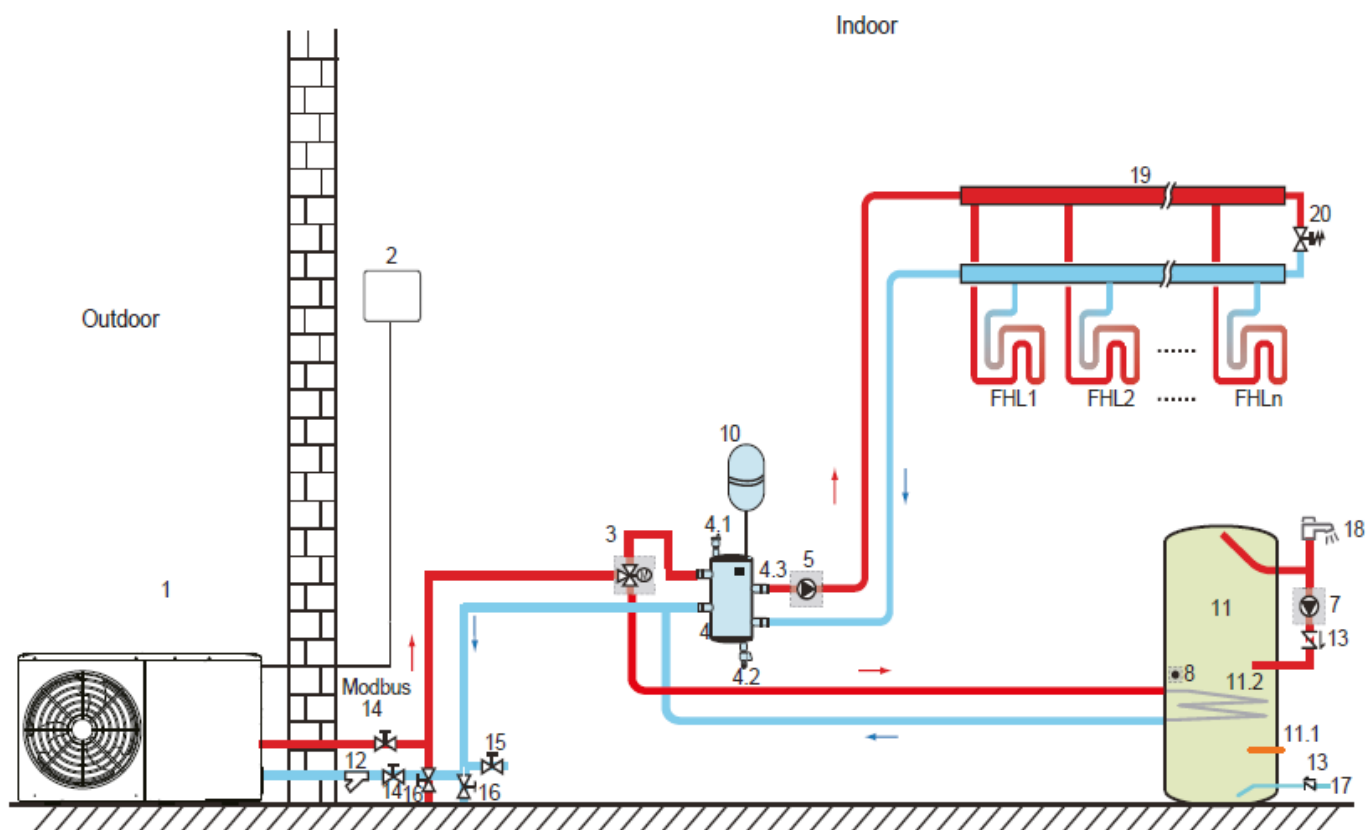

Code	Component	Code	Component
1	Main unit	11.1	TBH: domestic hot water tank booster heater (field supply)
2	User interface	11.2	Coil 1, heat exchanger for heat pump
3	SV1: 3-way valve (field supply)	12	Filter (accessory)
4	Balance tank (field supply)	13	Check valve (field supply)
4.1	Automatic air purge valve (field supply)	14	Shut-off valve (field supply)
4.2	Drainage valve (field supply)	15	Filling valve (field supply)
4.3	Tbt1: upper temperature sensor of balance tank (optional)	16	Drainage valve (field supply)
5	P_o: outside circulation pump (field supply)	17	Tap water inlet pipe (field supply)
7	P_d: DHW pipe pump (field supply)	18	Hot water tap (field supply)
8	T5: temperature sensor of domestic water tank (accessory)	19	Collector/distributor (field supply)
10	Expansion vessel (field supply)	20	Bypass valve (field supply)
11	Domestic hot water tank (field supply)	FHL 1...n	Floor heating loop (field supply)

**Control logic :**

- Space heating :

The ON/OFF signal, operation mode, and temperature are set on the user interface.

P\_o keeps running as long as the unit is ON for space heating while SV1 remains OFF.

- Domestic water heating

The ON/OFF signal and target tank water temperature (T5S) are set on the user interface.

P\_o stops running as long as the unit is ON for domestic water heating while SV1 remains ON.

- TBH (tank booster heater)

The TBH function is set on the user interface. (See 10.2.7 Other heat source)

1) When the TBH is set to be valid, TBH can be turned on via TANKHEATER function on the user interface; In DHW mode, TBH will be turned on automatically when the initial domestic water temperature T5 is too low or the target domestic water temperature is too high at low ambient temperature.

2) When the TBH is set to be valid, M1M2 can be set to be valid on the user interface. TBH will be turned on when the M1M2 dry contact closes.

### 6.1.2. Double-zone control

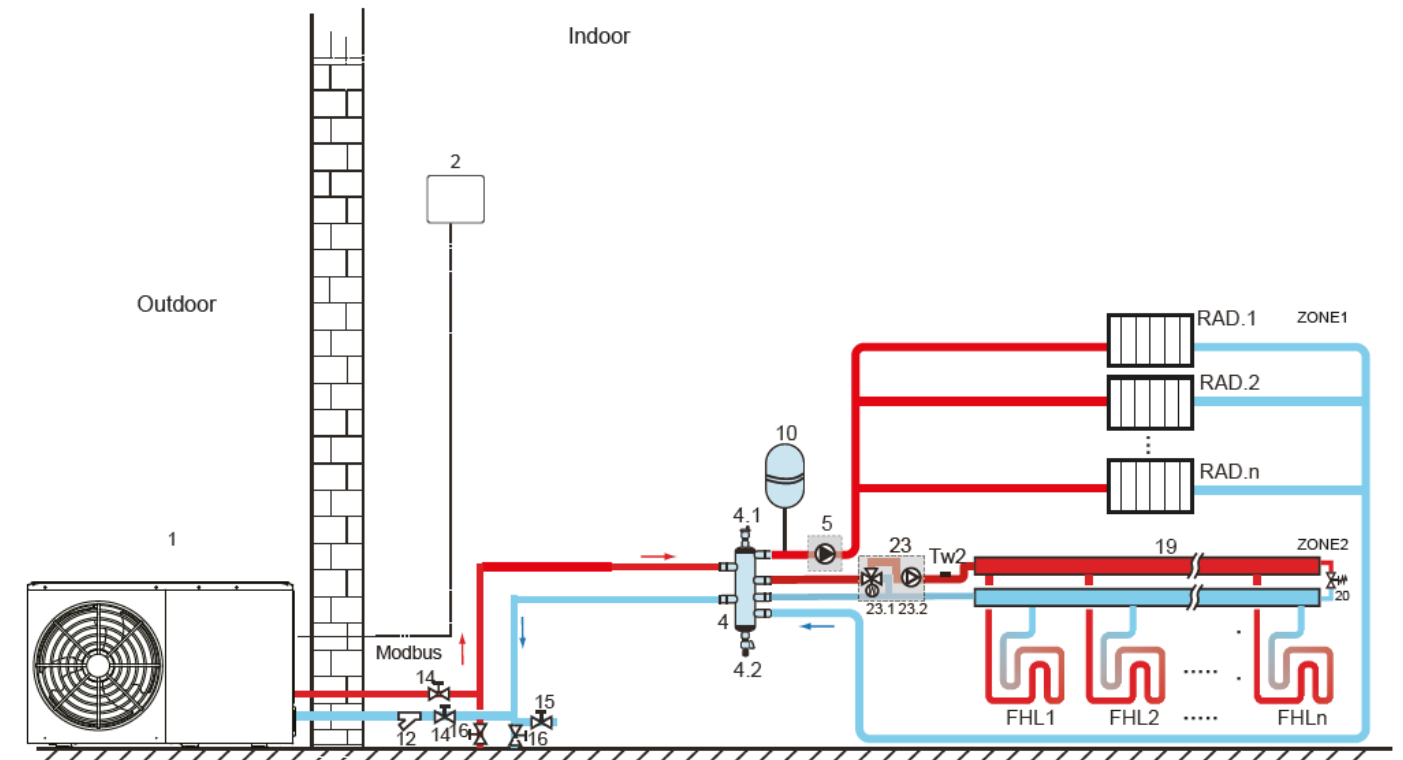

Code	Component	Code	Component
1	Main unit	15	Filling valve (field supply)
2	User interface	16	Drainage valve (field supply)
4	Balance tank (field supply)	19	Collector/distributor
4.1	Automatic air purge valve (field supply)	20	Bypass valve (field supply)
4.2	Drainage valve (field supply)	23	Mixing station (field supply)
4.3	Tbt1: upper temperature sensor of balance tank (optional)	23.1	SV3: mixing valve (field supply)
5	P_o: outside circulation pump (field supply)	23.2	P_c: Zone 2 circulation pump (field supply)
10	Expansion vessel (field supply)	Tw2	Zone 2 water flow temperature sensor (accessory)
12	Filter (accessory)	FHL 1...n	Floor heating loop (field supply)
14	Shut-off valve (field supply)	RAD.1...n	Radiator (field supply)



**Control logic :**

- Space heating :

The ON/OFF signal, operation mode, and temperature are set on the user interface.

P\_o keeps running as long as the unit is ON for Zone 1 for space heating while SV1 remains OFF.

P\_c keeps running as long as the unit is ON for Zone 2 for space heating while SV1 remains OFF.

SV3 is open & close according the water temperature Tw2.

## 6.2. Control through the wired controller and room thermostat

### 6.2.1. Single-zone control

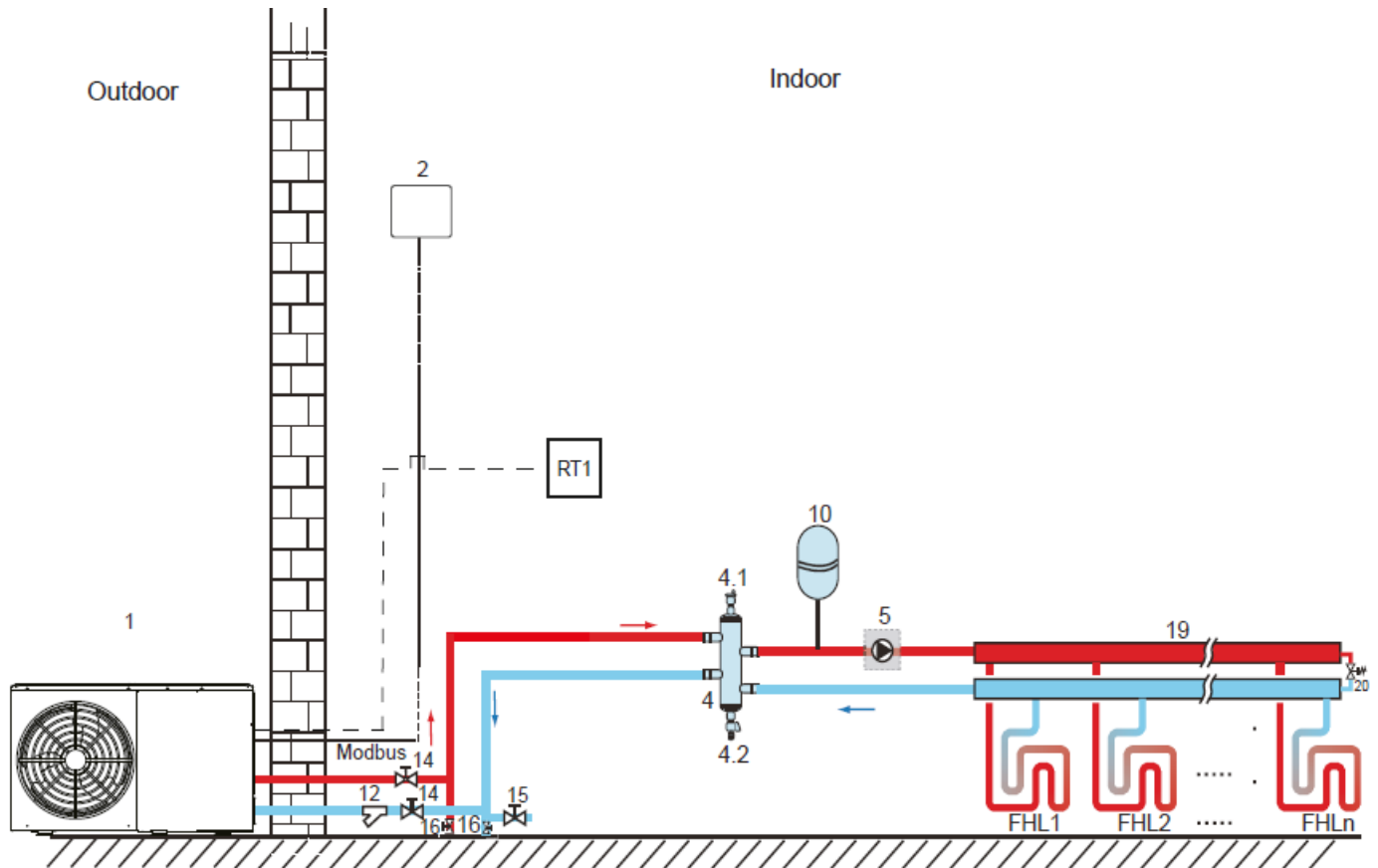

Code	Component	Code	Component
1	Main unit	12	Filter (accessory)
2	User interface	14	Shut-off valve (field supply)
4	Balance tank (field supply)	15	Filling valve (field supply)
4.1	Automatic air purge valve (field supply)	16	Drainage valve (field supply)
4.2	Drainage valve (field supply)	19	Collector/distributor (field supply)
4.3	Tbt1: upper temperature sensor of balance tank (accessory)	20	Bypass valve (field supply)
5	P_o: outside circulation pump (field supply)	FHL 1...n	Floor heating loop (field supply)
10	Expansion vessel (field supply)	RT1	Room thermostat (field supply)

**Control logic :**

- Space heating :

One-zone control: the unit ON/OFF is controlled by the room thermostat.

The cooling or heating mode and outlet water temperature are set on the user interface.

The system is ON when any "HL" of all the thermostats closes. When all "HLs" open, the system turns OFF.

- Circulation pump operation :

When the system turns ON, which means any "HL" of all the thermostats closes, P\_o starts running.

When the system turns OFF, which means all "HLs" open, P\_o stops running.

## 6.2.2. Control through mode setting

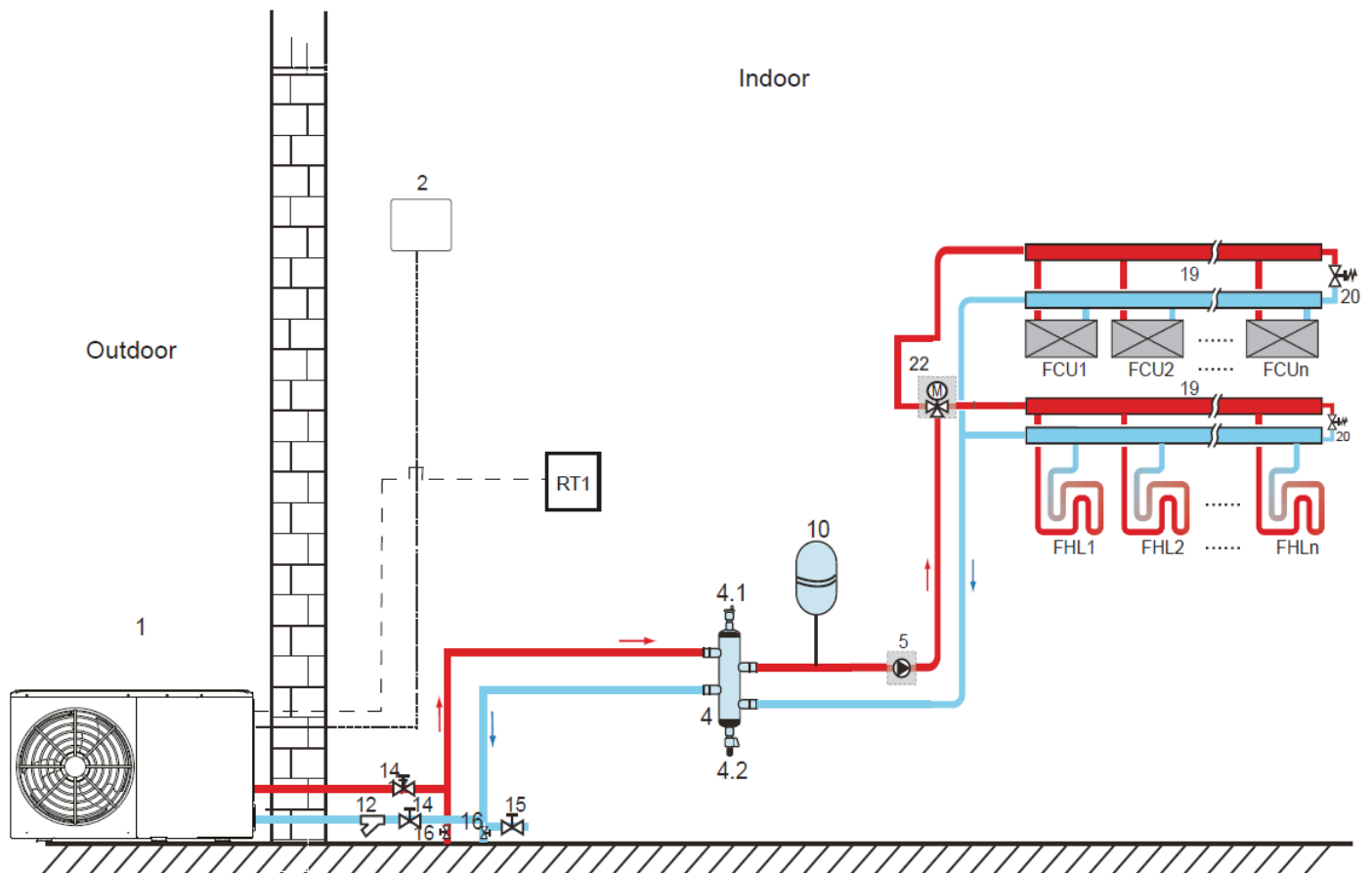

Code	Component	Code	Component
1	Main unit	14	Shut-off valve (field supply)
2	User interface	15	Filling valve (field supply)
4	Balance tank (field supply)	16	Drainage valve (field supply)
4.1	Automatic air purge valve (field supply)	19	Collector/distributor (field supply)
4.2	Drainage valve (field supply)	20	Bypass valve (field supply)
4.3	Tbt1: upper temperature sensor of balance tank (accessory)	22	SV2: 3-way valve (field supply)
5	P <sub>o</sub> : outside circulation pump (field supply)	FHL 1...n	Floor heating loop (field supply)
10	Expansion vessel (field supply)	FCU1...n	Fan coil unit (field supply)
12	Filter (accessory)	RT1	Room thermostat (field supply)

### Control logic :

- Space heating :

The cooling or heating mode is set via the room thermostat, and the water temperature is set on the user interface.

1) When any "CL" of all the thermostats closes, the system will be set to work in cooling mode.

2) When any "HL" of all the thermostats closes and all "CLs" open, the system will be set to work in heating mode.

- Circulation pump operation :

1) When the system is in cooling mode, which means any "CL" of all the thermostats closes, SV2 remains OFF while P<sub>o</sub> starts running.

2) When the system is in heating mode, which means one or more "HLs" close and all "CLs" open, SV2 remains ON while P<sub>o</sub> starts running.

## 6.2.3. Double-zone control

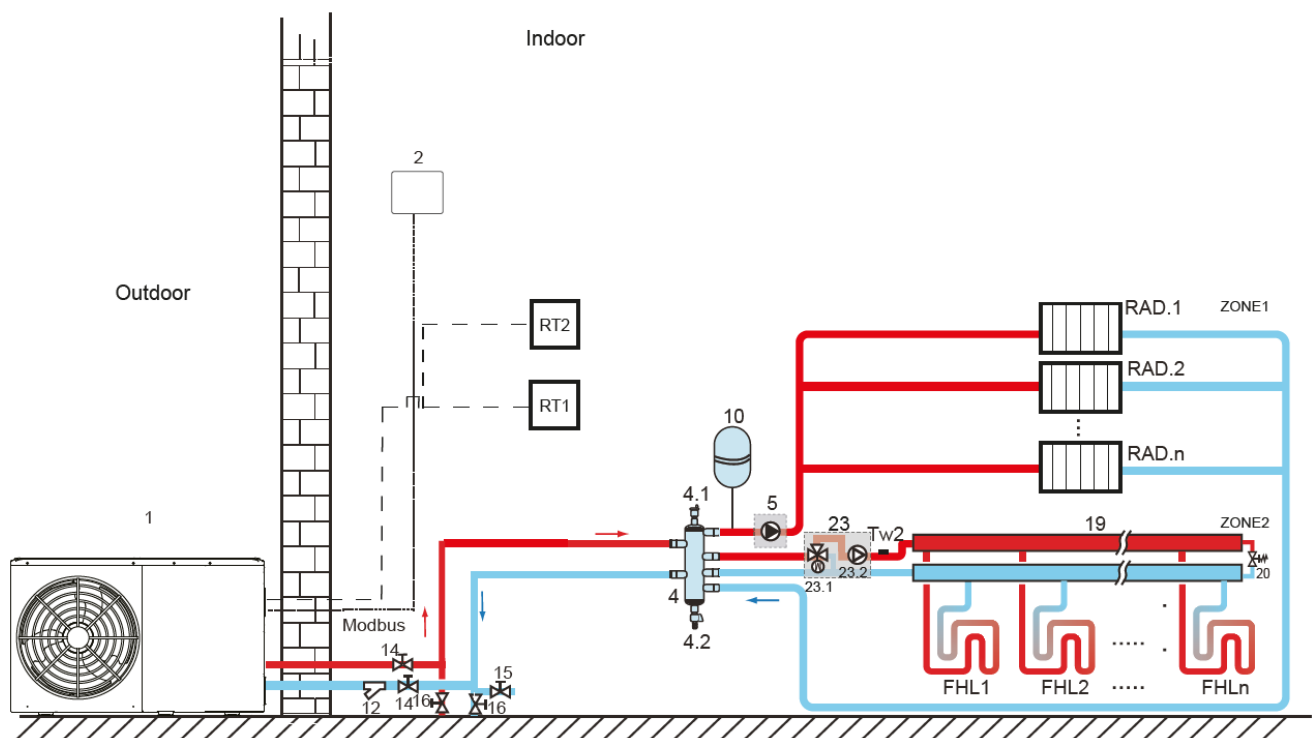

Code	Component	Code	Component
1	Main unit	16	Drainage valve (field supply)
2	User interface	19	Collector/distributor
4	Balance tank (field supply)	20	Bypass valve (field supply)
4.1	Automatic air purge valve (field supply)	23	Mixing station (field supply)
4.2	Drainage valve (field supply)	23.1	SV3: mixing valve (field supply)
4.3	Tbt1: upper temperature sensor of balance tank (optional)	23.2	P_c: Zone 2 circulation pump (field supply)
5	P_o: outside circulation pump (field supply)	Tw2	Zone 2 water flow temperature sensor (accessory)
10	Expansion vessel (field supply)	FHL 1...n	Floor heating loop (field supply)
12	Filter (accessory)	RAD.1...n	Radiator (field supply)
14	Shut-off valve (field supply)	RT1	Room thermostat zone1 (field supply)
15	Filling valve (field supply)	RT2	Room thermostat zone2 (field supply)

### Control logic :

- Space heating :

Zone1 can operate in cooling mode or heating mode, while Zone2 can only operate in heating mode; During installation, for all thermostats in Zone1, only "HL" terminals need to be connected. For all thermostats in Zone2, only "CL" terminals need to be connected.

1) The ON/OFF of Zone1 is controlled by the room thermostats there. When any "HL" of all thermostats in Zone1 closes, Zone 1 turns ON. When all "HLs" turn OFF, Zone 1 turns OFF; The target temperature and operation mode are set on the user interface.

2) In heating mode, the ON/OFF of Zone2 is controlled by the room thermostats there. When any "CL" of temperature is set on the user interface; Zone 2 can only operate in heating mode. When cooling mode is set on the user interface, Zone2 remains OFF.

- Circulation pump operation :

When Zone1 turns ON, P\_o starts running; When Zone1 turns OFF, P\_o stops running;

When Zone2 turns ON, SV3 switches between ON and OFF according to the set TW2, and P\_c remains ON; When Zone 2 turns OFF, SV3 remains OFF and P\_c stops running.

The floor heating loops require a lower water temperature in heating mode than radiators or fan coil units. To reach the set temperature points, a mixing station is used to adapt the water temperature according to requirements of the floor heating loops. The radiators are directly connected to the unit's water circuit and the floor heating loops and after the mixing station. The mixing station is controlled by the unit.

## 7. HYDRAULIC INSTALLATION

### 7.1. Preparations for Installation

#### NOTE

In case of plastic pipes, make sure they are fully oxygen-tight according to DIN 4726. The diffusion of oxygen into the piping can lead to excessive corrosion.

#### 7.1.1. Minimum water volume

Verify that the total water volume in the installation is at least 40L, excluding the internal water volume of the outdoor unit.

#### NOTE

Extra water might be required in critical processes or in rooms with a high heating load. When circulation in each space heating/cooling loop is controlled by remotely controlled valves, it is necessary to guarantee the minimum water volume, even if all of the valves are closed.

#### 7.1.2. Maximum water volume

Determine the maximum water volume for the calculated pre-pressure based on the following graph and formula.

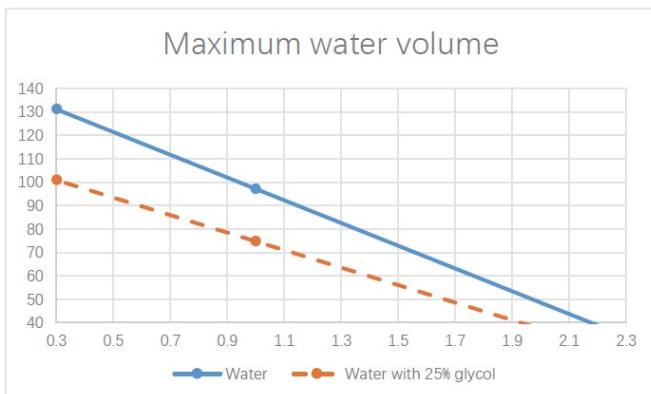

Vw\_max – maximum water volume (L)  
Pg – pre-pressure (bar)

System with only water	$V = 48.54 * (3 - P_g)$
System with 25% glycol	$V = 37.34 * (3 - P_g)$

#### 7.1.3. Flow rate range

Verify that the minimum flow rate in the installation is guaranteed in all conditions. This rate is required during defrosting/ backup heater operation.

#### NOTE

When one or more heating circuits are controlled by remotely controlled valves, the minimum water flow needs to be guaranteed, even if all valves are closed. If the minimum flow rate cannot be satisfied, E0 and E8 (unit shutdown) will be triggered.

Unit	Flow rate range
4kW	0.40 - 0.90 m <sup>3</sup> /h
6kW	0.40 - 1.25 m <sup>3</sup> /h
8kW	0.40 - 1.65 m <sup>3</sup> /h
10kW	0.40 - 2.10 m <sup>3</sup> /h
12kW	0.70 - 2.50 m <sup>3</sup> /h
14kW	0.70 - 2.75 m <sup>3</sup> /h
16kW	0.70 - 3.00 m <sup>3</sup> /h

#### 7.1.4. Pre-pressure adjustment of the expansion vessel

The unit is equipped with an expansion vessel of 8 L that has a default pre-pressure of 1.5 bar. To assure proper operation of the unit, the pre-pressure of the expansion vessel needs to be adjusted.

1) Verify that the total water volume in the installation, excluding the internal water volume of the unit, is at least 40 L.

2) The calculation of the pre-pressure (Pg) of the expansion vessel is shown in the formula below:

$$P_g = 0.3 + (H/10) \text{ (bar)}$$

H - installation height difference

3) Rotate and remove the protective cap, and pressurize (with nitrogen) or vent the expansion vessel through the Schrader valve.

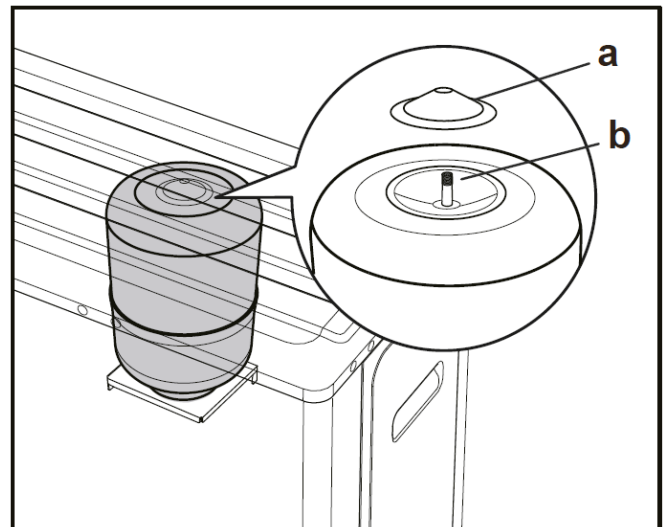

a – Top cover  
b - Schrader valve

#### 7.1.5. Requirements for third-party tanks

A third-party tank, if used, should meet the following requirements:

- The heat exchanger coil of the tank is  $\geq 1.05 \text{ m}^2$ .
- The tank thermistor must be located above the heat exchanger coil.
- The booster heater must be located above the heat

## NOTE

### •Performance

Performance data for third-party tanks is unavailable, and the performance CANNOT be guaranteed.

### •Configuration

Configuration of a third-party tank depends on the size of the heat exchanger coil of the tank.

For installation of the domestic hot water tank (supplied by the user), refer to the specific manual of the domestic hot water tank.

## 7.1.6. Thermistor of domestic hot water tank

The maximum allowable thermistor cable length is 20 m, which is equal to the maximum allowable distance between the domestic hot water tank and the unit (only for installation with a domestic hot water tank). The thermistor cable supplied with the domestic hot water tank is 10 m in length.

## 7.1.7. Requirements for balance tank volume

For balance tank selection, refer to 5.5 Balance tank.

## 7.1.8. Field connection of hydraulics parts

When a 3-way valve is to be used in the water circuit, a ball valve is recommended to guarantee full separation between the domestic hot water circuit and the floor heating water circuit.

When a 3-way valve or a 2-way valve is used in the water circuit, the recommended valve changeover time is less than 60 seconds.

To optimize unit efficiency, you are advised to install the 3-way valve and the domestic hot water tank as close as possible to the unit.

## 7.2. Water Circuit Connection

### Typical workflow

Connecting the water circuit typically consists of the following steps:

- 1) Connect the water piping to the outdoor unit.
- 2) Connect the drain hose to the drain.
- 3) Fill the water circuit.
- 4) Fill the domestic hot water tank (if available).
- 5) Insulate the water piping.

## Requirements

### NOTE

- The pipe inside must be clean.
- Hold the pipe end downwards when removing burrs.
- Cover the pipe end when inserting the pipe through a wall to prevent dust and dirt from entering the pipe.
- Use proper thread sealant to seal the connections. The sealing must be able to withstand the pressure and temperature of the system.
- When using non-copper metallic piping, be sure to insulate two kinds of materials from each other to prevent galvanic corrosion.
- Copper is soft. Use appropriate tools to avoid damage.
- Zn-coated parts cannot be used.
- Always use materials that do not react with the water used in the system and with the materials used in the unit.
- Ensure that components installed in the field piping can withstand the water pressure and temperature.

### CAUTION

Incorrect orientation of water outlet and inlet could cause unit malfunction.

Do NOT apply excessive force when connecting the field piping and make sure the piping is aligned properly. Water piping deformation could cause unit malfunction.

The unit is only to be used in a closed water system.

- 1) Connect the Y-shaped strainer to the water inlet of the unit, and seal the connection with thread sealant. (To provide access to the Y-shaped strainer for cleaning, an extension pipe can be connected between the strainer and the water inlet depending on the field conditions)
- 2) Connect the pipe provided on the site to the water outlet of the unit.
- 3) Connect the outlet of the safety valve with a hose with a suitable size and length, and guide the hose to the condensate 5.4.2 Drainage layout.

### NOTE

The installation of the Y-shaped strainer at the water inlet is mandatory

Pay attention to the correct flow direction of the Y-shaped strainer.

4-6 kW/8-16 kW

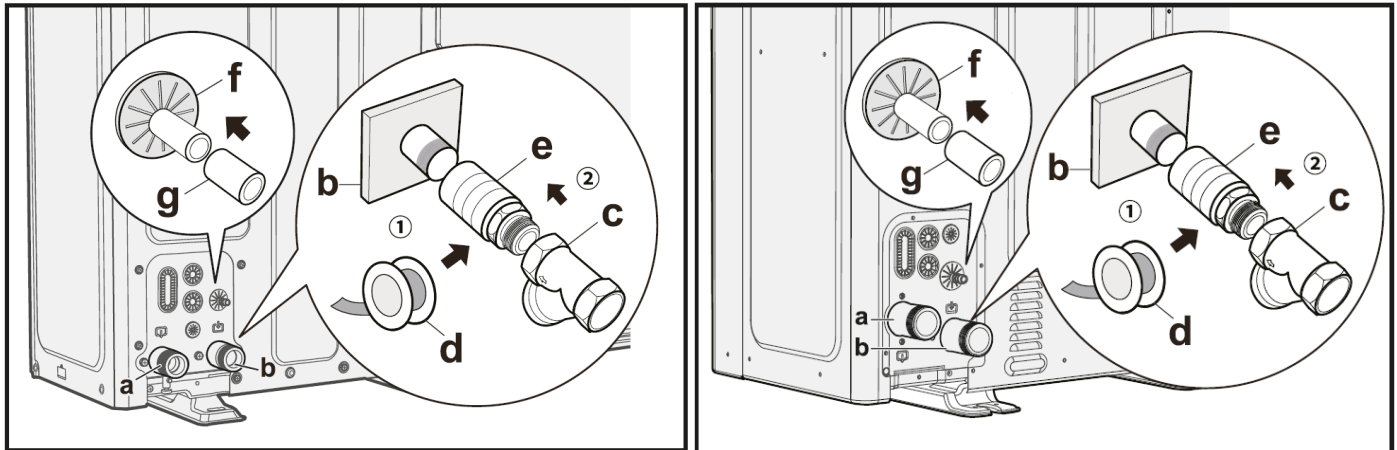

a	Water OUTLET (connection with screws, male, 1" for 4/6 kW units and 1 1/4" for 8-16 kW units)
b	Water INLET (connection with screws, male, 1" for 4/6 kW units and 1 1/4" for 8-16 kW units)
c	Y-shaped strainer (delivered with the unit) (2 screws for connection, female, 1" for 4/6 kW
d	units and 1 1/4" for 8-16 kW units)
e	Thread seal tape
f	Extension pipe (recommended, with the length depending on the field conditions)
g	Safety valve outlet (hose, $\phi$ 16mm)

## Domestic hot water

For the installation of the domestic hot water tank (supplied on the site), refer to the specific manual of the domestic hot water tank.

## Others

### NOTE

*Air vent valves must be installed at high points of the system.*

*Drain taps must be installed at low points of the system.*

## 7.3. Water

### Checking and treating the heating water/filling and supplementing water

Before filling or topping up the installation, check the quality of the heating water.

### NOTE

*Risk of material damage due to poor-quality heating water.*

*Ensure that the heating water is of sufficient quality.*

*Water quality should be complied with EN 98/83 EC Directives.*

### Checking the filling and supplementary water

Before filling the installation, measure the hardness of the filling and supplementary water.

### Checking the quality of the heating water

- 1) Remove a little water from the heating circuit.
- 2) Check the appearance of the heating water.

If it is determined that the heating water contains sedimentary materials, be sure to desludge the installation.

- 3) Use a magnetic rod to check whether the heating

water contains magnetite (iron oxide).

If you ascertain that it contains magnetite, clean the installation and take suitable corrosion-inhibition measures, or install a magnetite separator.

- 4) Check the pH value of the removed water at 25 °C.

If the value is below 8.2 or above 10.0, clean the installation and treat the heating water.

### NOTE

*Ensure that oxygen cannot get into the heating water.*

### Treating the filling and supplementary water

Observe all applicable national regulations and technical rules when treating the filling and supplementary water.

Provided the national regulations and technical rules do not stipulate more stringent requirements, the following applies:

You must treat the heating water in the following cases.

- If the entire filling and supplementary water quantity during the service life of the system exceeds three times the nominal value of the heating installation, or
- If the guideline values listed in the following table are not met, or
- If the pH value of the heating water is smaller than 8.2 or larger than 10.0.

## 7.4. Filling Water Loop with Water

### NOTE

Before filling with water, please check 6.3 Water for the water quality requirements. Pumps and valves may become stuck as a result of poor water quality.

Connect the water supply to the filling valve and open the valve. Follow applicable regulations. Make sure the automatic air vent valve is open. Ensure a water pressure of approximately 2.0 bar. Remove the air in the loop as much as possible using the air vent valves. Air in the water loop could lead to malfunction of the backup electric heater.

Do not fasten the black plastic cover on the vent valve at the top side of the unit when the system is running. Open the air vent valve, and turn it anticlockwise at least 2 full turns to release air from the system.

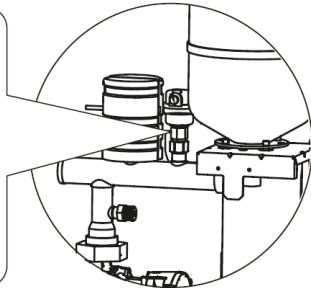

### NOTE

During filling, it might not be possible to remove all air from the system. Remaining air will be removed through the automatic air purge valves during the first operation of the system. Topping up with water afterwards might be required. The water pressure will vary with the water temperature (a higher pressure at a higher water temperature). Always keep the water pressure above 1.3 bar to prevent air from entering the loop. The unit might drain off too much water through the pressure relief valve.

Maximum water pressure	3 bar
------------------------	-------

## 7.5. Filling Domestic Hot Water Tank with Water

See the specific manual of the domestic hot water tank.

## 7.6. Water Pipe Insulation

The complete water loop including all pipes, must be insulated to prevent condensation during cooling operation, heating and cooling capacity reduction, and freezing of the outside water pipes in winter.

### NOTE

The insulation material should be provided with a fire resistance rating of B1 or above and comply with all applicable regulations. The thermal conductivity of the sealing material should be below 0.039 W/mK.

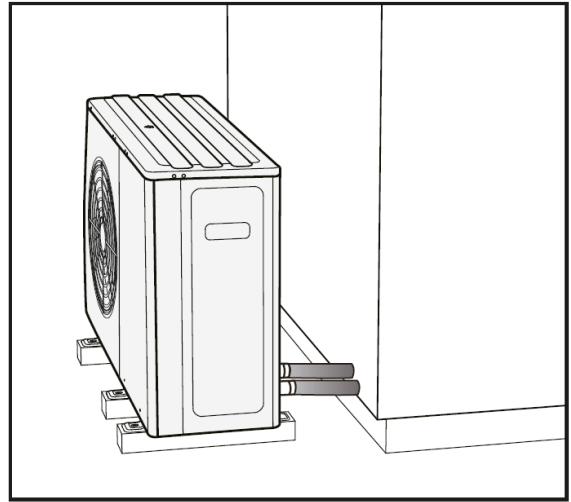

Recommended thickness of the sealing material is shown as below.

Piping length (m) between the unit and the terminal device	Minimum insulation thickness(mm)
< 20	19
20~30	32
30~40	40
40~50	50

If the outdoor ambient temperature is higher than 30°C and the humidity is higher than RH 80%, the thickness of the sealing materials should be at least 20 mm to avoid condensation on the surface of the seal.

## 7.7. Freeze Protection

### 7.7.1. Protected by software

The software is equipped with specific functions to protect the entire system from freezing by using the heat pump and the backup heater.

When the temperature of the water flow in the system drops to a certain value, the unit will heat the water using the heat pump, electric heating tape, or backup heater.

The anti-freeze function is enabled only when the temperature increases to a certain value.

### CAUTION

In the event of power failure, the above features would fail to protect the unit from freezing. Therefore, always keep the unit powered on.

If the power supply for the unit is to be switched off for a long time, the water in the system pipe needs to be drained to avoid damage to the unit and pipeline system due to freezing.

In case of power failure, add glycol to the water. Glycol lowers the freezing point of the water.

## 7.7.2. Protected by glycol

Glycol lowers the freezing point of water.

### CAUTION

*Ethylene glycol and propylene glycol are toxic.*

### CAUTION

*Glycol can corrode the system. When uninhibited glycol comes into contact with oxygen, it becomes acidic. This corrosion process is accelerated by copper and high temperature. The acidic uninhibited glycol attacks metal surfaces, forming galvanic corrosion cells that can cause severe damage to the system. Therefore, it is important to follow these steps:*

- *Let a qualified specialist treat the water correctly;*
- *Select a glycol with corrosion inhibitors to counteract acids formed by the oxidation of glycols;*
- *Do not use any automotive glycol because its corrosion inhibitors have a limited lifetime and contain silicates which can contaminate or block the system;*
- *Do not use galvanized pipes in glycol systems as such pipes may lead to the precipitation of certain components in the glycol's corrosion inhibitor.*

### NOTE

*Glycol absorbs moisture from the environment, so it is important to avoid using glycol exposed to air. If glycol is left uncovered, the water content increases, lowering the glycol concentration and potentially causing hydraulic components to freeze. To prevent this, take precautions and minimize glycol's exposure to air.*

### Types of glycol

The types of glycol that can be used depend on whether the system contains a domestic hot water tank:

The system contains a domestic hot water tank	Only use propylene glycol (a)
The system does NOT contain a domestic hot water tank	Either propylene glycol(a) or ethylene glycol can be used

(a) Propylene glycol, including the necessary inhibitors, falls in Category III according to EN1717.

### Required concentration of glycol

The required concentration of glycol depends on the lowest expected outdoor temperature, and on whether you want to protect the system from bursting or from freezing. To prevent the system from freezing, more glycol is required.

Add glycol according to the table below.

Lowest expected outdoor temperature	Prevention from bursting	Prevention from freezing
-5°C	10%	15%
-10°C	15%	25%
-15°C	20%	35%
-20°C	25%	N/A*
-25°C	30%	N/A*
-30°C	35%	N/A*

\* Additional action is needed to prevent freezing.

Protection from bursting: Glycol can prevent the piping from bursting, but cannot prevent the liquid inside the piping from freezing.

Protection from freezing: Glycol can prevent the liquid inside the piping from freezing.

### NOTE

*The required concentration might vary depending on the type of glycol used. ALWAYS compare the requirements from the table above with the specifications provided by the glycol manufacturer. If necessary, meet the requirements set by the glycol manufacturer.*

*The added concentration of glycol should NEVER exceed 35%.*

*If the liquid in the system is frozen, the pump will NOT be able to start. Please note that solely preventing the system from bursting may not prevent the liquid inside from freezing.*

*If water remains stagnant within the system, it is highly likely to freeze and result in system damage.*

### Glycol and the maximum allowed water volume

Adding glycol to the water circuit reduces the maximum allowed water volume of the system.

## 7.7.3. About freeze protection valves (field supplied)

### NOTE

*Do NOT install freeze protection valves, if glycol is added to the water. Otherwise, glycol may leak from the freeze protection valves.*

When no glycol is added to the water, you can use freeze protection valves to drain the water from the system before it freezes.

Install freeze protection valves (supplied by the user) at all lowest points of the field piping.

Normally closed valves (located indoors near the piping entry/exit) can prevent drainage of water from indoor piping when the freeze protection valves are open.

### NOTE

*When freeze protection valves are installed, ensure the minimum cooling set point is 7°C (7°C=default). Otherwise, freeze protection valves can open during cooling operation.*



## 7.7.4. Measure without freeze protection

In cold environments, if there is no antifreeze (e.g. glycol) in the system or lasting power failure or pump failure is foreseen, drain the system (as shown in the figure below).

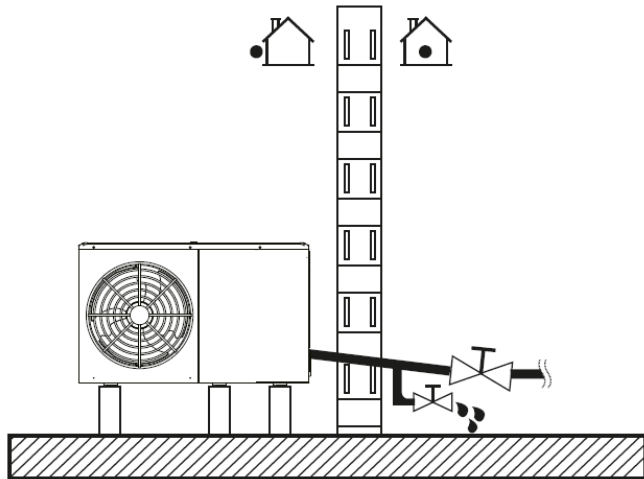

### NOTE

*If water is not removed from the system in freezing weather when the unit is not in use, the frozen water may damage the water circle parts.*

## 7.7.5. Freeze protection for water circuit

All internal hydronic parts are insulated to reduce heat loss. The field piping must also be insulated. In the event of a power failure, the above features would not protect the unit from freezing.

The software contains special functions using the heat pump and backup heater (if optional and available) to protect the entire system from freezing. When the temperature of the water flow in the system drops to a certain value, the unit will heat the water, either using the heat pump, the electric heating tap, or the backup heater. The anti-freeze function will be disabled only when the temperature increases to a certain value.

Water may enter the flow switch and cannot be drained out, and may freeze when the temperature is low enough. The flow switch should be removed and dried before being installed in the unit.

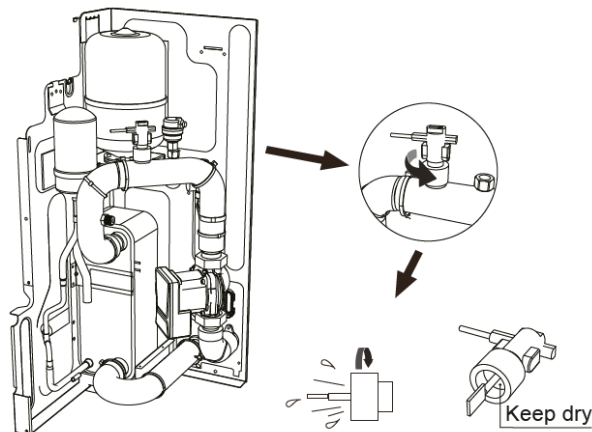

### NOTE

*Rotate the flow switch counterclockwise to remove it. Dry the flow switch completely.*

## 7.8. Check of Water Circuit

The conditions below should be met before installation:

- The maximum water pressure is smaller than or equal to 3 bar.
- The maximum water temperature is smaller than or equal to 75°C according to safety device setting.
- Drain taps must be installed at all low points of the system to ensure complete drainage of the circuit during maintenance.
- Air purge valves must be installed at all high points of the system. The vents should be located at points that are easily accessible for service. An automatic air purge valve is provided inside the unit. Verify that this air purge valve is not tightened so that automatic release of air from the water circuit is possible.

## 8. ELECTRICAL INSTALLATION

### DANGER

Risk of electrocution.

### 8.1. Opening the Electrical Box Cover

To access the unit for installation and maintenance, follow the instructions below.

### WARNIG

Risk of electrocution.

Risk of burning.

### NOTE

Illustrations below are based on 8-16 kW units.

The principle is the same for 4-6 kW units.

Keep the screws properly for later use.

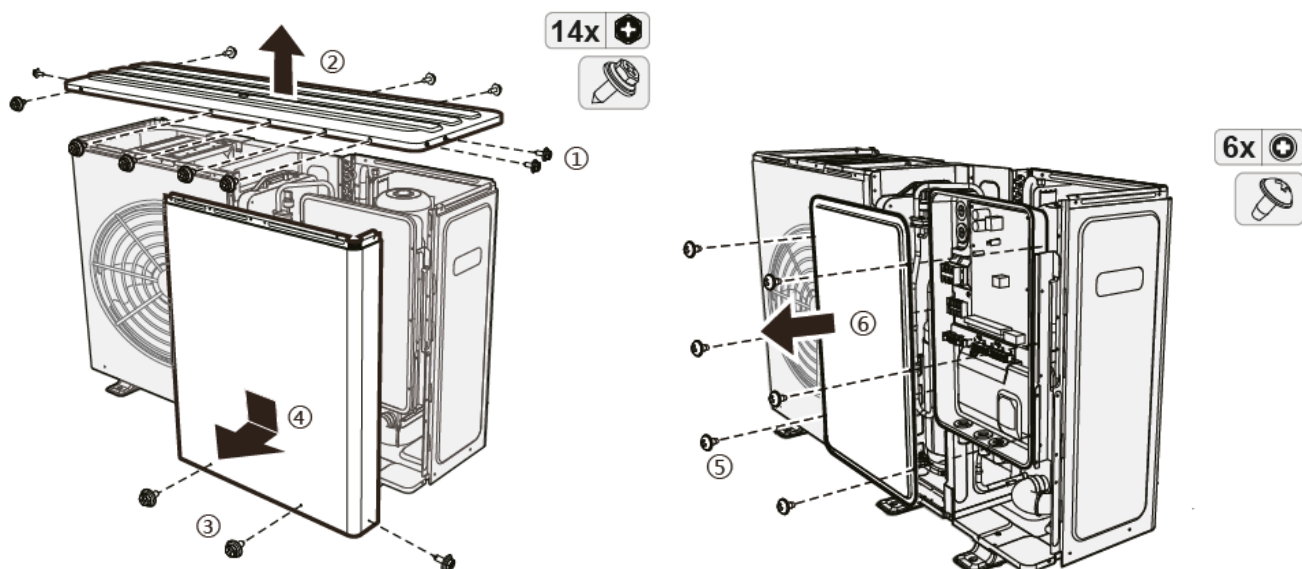

## 8.2. Opening the Electrical Box Cover

### **WARNING**

*The wiring must comply with local laws and regulations.*

*Follow the electrical wiring diagrams for electrical wiring (the electrical wiring diagrams are located on the rear side of the switch box service panel).*

### **CAUTION**

*A main switch or other means of disconnection, such as having a contact separation in all poles, must be incorporated in the fixed wiring in accordance with relevant local laws and regulations.*

*Use only copper wires.*

*Never squeeze bundled cables and keep them away from piping and sharp edges.*

*Make sure no external pressure is applied to the terminal connections.*

*The field wiring must be carried out in accordance with the wiring diagram supplied with the unit and the instructions given below.*

*Be sure to use a dedicated power source, instead of a power source shared by another appliance.*

*Earth the unit properly, including the wired controller. Do not connect the unit to a utility pipe, surge protector, or telephone earth. Incomplete earthing may cause electrocution.*

*An earth fault circuit interrupter (30 mA) must be installed to avoid electrical shock. Use 3-core shielded wires.*

*Be sure to install the required fuses or circuit breakers.*

*A leakage protection switch must be installed to the power supply of the unit.*

*Attach an earth fault circuit interrupter and fuse to the power supply line.*

### **Power cable and communication cable**

### **NOTE**

*Communication wires must be shielded, including the unit-to-controller ABXYE line.*

*Use H07RN-F as the power cable. Only the thermistor and user interface wiring are provided with low voltage.*

*Power cables and communication wires must be laid out separately, and cannot be placed in the same conduit.*

*Otherwise, electromagnetic interference may occur.*

*Secure the electrical wires with cable ties so that they will not come in contact with the piping, particularly on the high-pressure side.*

*The unit is equipped with an inverter. A phase advancing capacitor will reduce the power factor improvement effect, and may cause abnormal heating of the capacitor due to high-frequency waves. Installing a phase advancing capacitor is not permitted.*

*The external load current should be lower than 0.2 A. If the single load current is higher than 0.2 A, the load must be controlled through an AC contactor.*

*"AHS1" and "AHS2" terminal ports only provide on/off signals.*

*The expansion valve E-heating tape, plate heat exchanger E-heating tape, and flow switch E-heating tape share the same terminal port.*

### **Earthing**

### **NOTE**

*The equipment must be earthed.*

*Any high-voltage external load, if it is metal or an earthed port, must be earthed.*

*Make sure the earth fault circuit interrupter is compatible with the inverter (resistant to high frequency electrical noise) to avoid unnecessary startup of the interrupter.*

## 8.3. Opening the Electrical Box Cover

### 8.3.1. Field wiring guidelines

- Most field wiring of the unit is to be made on the terminal block inside the switch box. To gain access to the terminal block, remove the switch box service panel.
- Fix all cables with cable ties.
- The backup heater requires a dedicated power circuit.
- Installations equipped with a domestic hot water tank (supplied by the user) require a dedicated power circuit for the booster heater.
- Please refer to the Installation & Owner's Manual of the domestic hot water tank. Secure the wiring in the order shown
  - below.
- Lay out the electrical wires so that the front cover does not rise up during the wiring, and attach the front cover securely.
- Install the wires and fix the cover firmly so that the cover may be fit properly.

### 8.3.2. Operating current and wire diameter

- 1) Select the wire diameter ( minimum value) individually for each unit based on Table 7-1 and Table 7-2. The rated current in Table 7-1 means MCA in Table 7-2. In case the MCA exceeds 63 A, the wire diameters should be selected according to the local wiring regulation.
- 2) The maximum allowable voltage deviation between phases is 2%.
- 3) Select circuit breakers that have a contact separation of at least 3 mm in all poles for full disconnection. MFA is used to select the current circuit breakers and residual current operation breakers.
- 4) The inverter PCB is equipped with an overcurrent protector (fuse). In case any additional overcurrent protector is needed, refer to the TOCA in Table 7-2.

#### NOTE

- (a) Minimum cable section AWG18 (0.75 mm<sup>2</sup>).
- (b) The thermistor cable is delivered with the unit.

**Table 7-1**

Rated current (A)	Nominal cross-sectional area (mm <sup>2</sup> )	
	Flexible cord	Cable for fixed wiring
≤3	0.5 and 0.75	1 and 2.5
>3 and ≤6	0.75 and 1	1 and 2.5
>6 and ≤10	1 and 1.5	1 and 2.5
>10 and ≤16	1.5 and 2.5	1.5 and 4
>16 and ≤25	2.5 and 4	2.5 and 6
>25 and ≤32	4 and 6	4 and 10
>32 and ≤50	6 and 10	6 and 16
>50 and ≤63	10 and 16	10 and 25

**Table 7-2**

Model	Outdoor unit				Power current			Compressor		Fan motor	
	Voltage (V)	Hz	Min. (V)	Max. (V)	MCA (A)	TOCA (A)	MFA (A)	MSC (A)	RLA (A)	kW	FLA (A)
4kW	220-240	50	198	264	12	16	20		10	0.08	0.32
6kW	220-240	50	198	264	13.5	16	20		10	0.08	0.32
8kW	220-240	50	198	264	16	20	25		13	0.17	0.80
10kW	220-240	50	198	264	17.5	20	25		13	0.17	0.80
12kW	220-240	50	198	264	25	31	32		18	0.2	0.80
14kW	220-240	50	198	264	26.5	31	32		18	0.2	0.80
16kW	220-240	50	198	264	28	31	32		18	0.2	1.30
12kW 3-PH	380-415	50	342	456	8.5	11	16		18	0.2	0.57
14kW 3-PH	380-415	50	342	456	9	11	16		18	0.2	0.57
16kW 3-PH	380-415	50	342	456	9.5	11	16		18	0.2	1.25

## Backup heater

Model	Outdoor unit				Power current		
	Voltage (V)	Hz	Min. (V)	Max. (V)	MCA (A)	TOCA (A)	MFA (A)
3kW 1-PH	220-240	50	198	264	13.5	13.5	20
3kW 3-PH	380-415	50	342	456	4.5	4.5	20
6kW 3-PH	380-415	50	342	456	9	9	20
9kW 3-PH	380-415	50	342	456	13.5	13.5	20

MCA: min. circuit current (A) KW : rated motor output MFA: max. fuse current (A)

TOCA: total over current (A) FLA : full-load current (A) MSC: max. starting current (A)

RLA: rated load amps (A); the rated input current of the compressor at the maximum frequency (max hz) when the unit is running in cooling or heating mode

### 8.3.3. Tightening torque and tie wrap

Item	Tightening torque (N·m)
M4 (power terminal, electric control board terminal)	1.2-1.5
M4 (earthing)	1.2-1.5

#### NOTE

Over-tightening might damage the screws.

Tighten the screws with a proper screwdriver. Using an improper screwdriver could damage the screws and provide improper tightening torques.

### 8.3.4. Back plate layout for wiring

#### 4-6 kW 8-16 kW

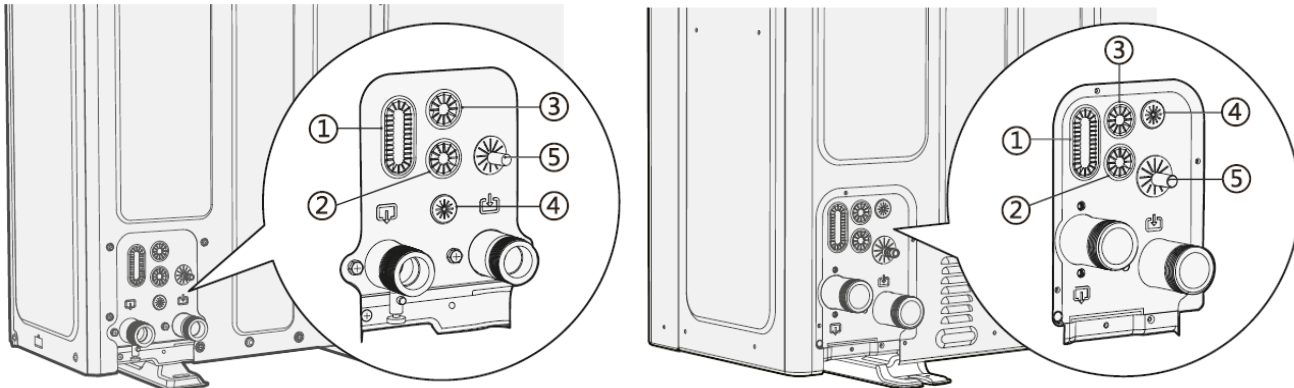

①②③	For high voltage wiring.
④	For low voltage wiring.
⑤	Safety valve drain.

## 8.4. Connection with Power Supply

### 8.4.1. Precautions

For connection of the unit to a power supply terminal, the terminal should be a circular wiring terminal with an insulation casing (see Figure 7.1).

If it is impossible to use such a circular wiring terminal, observe the following instructions:

- Use a power cord that conforms to the specifications and connect the power cord firmly. Apply a proper tightening torque shown in the above section (Tightening torques) to prevent the cord from being accidentally pulled out by an external force.

- Do not connect two power cords with different diameters to the same power supply terminal. Otherwise, the wires may overheat due to loose wiring (See Figure 7.2).

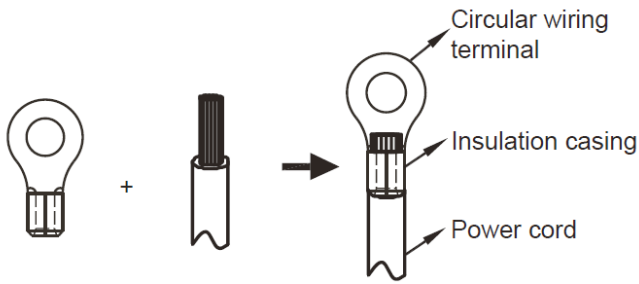
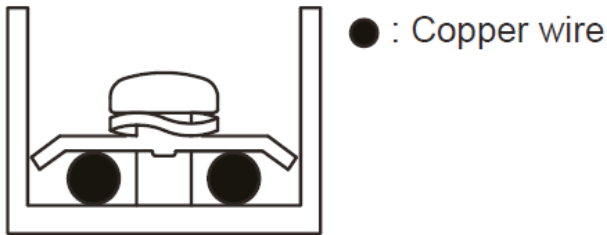

Figure 7.1



Proper power wiring connections

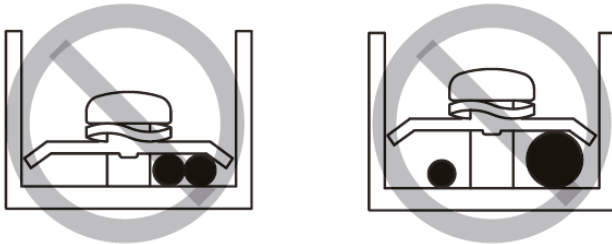

Figure 7.2

## 8.4.2. Wiring of main power supply

### NOTE

Use a round crimp-style terminal for connection to the power supply terminal board.

- The power cord model is H05RN-F or H07RN-F.
- Illustrations below are for 3-phase units. The principle is the same for 1-phase units.
- Illustrations below are for units with a backup heater.

1-phase with backup heater.

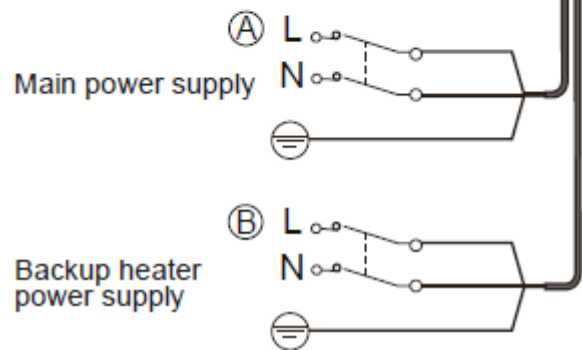
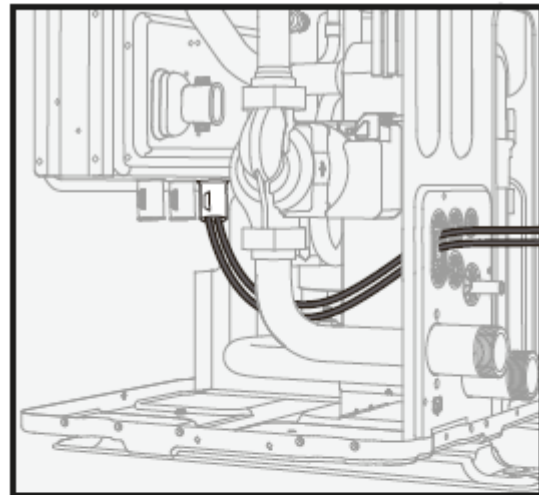
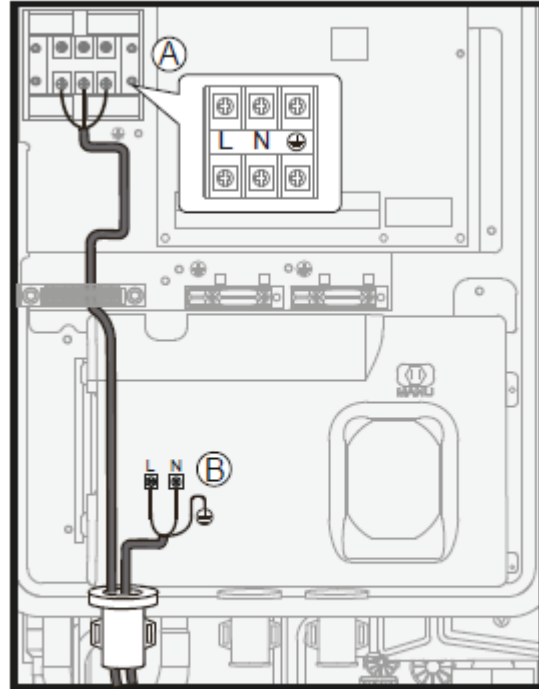

### NOTE

Leakage protection switch must be installed.

3-phase with backup heater.

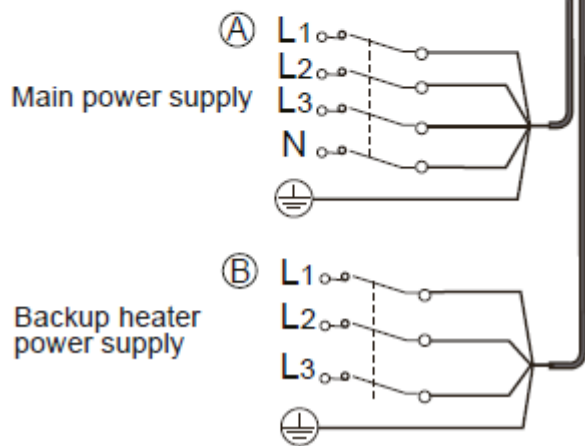
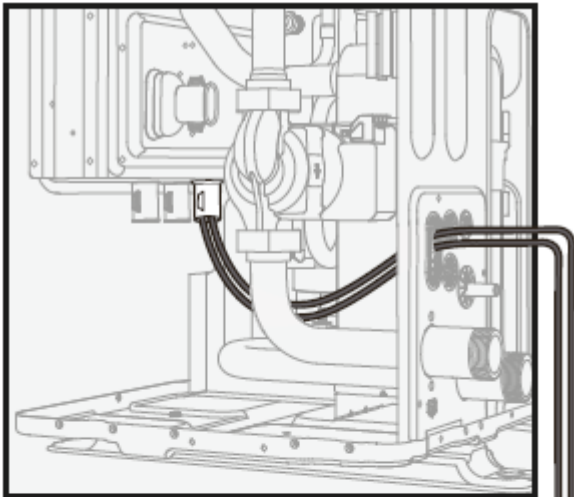
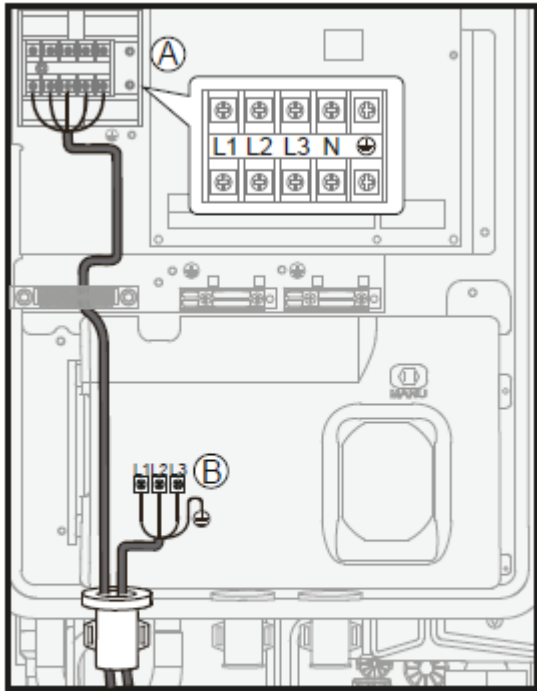

**NOTE**

Leakage protection switch must be installed.

## 8.5. Control board

### 8.5.1. Main control board

The main control board is the same board for the model, 4-6 kW, 8-10 kW, 12-14-16 kW 1ph, 12-14-16 kW 3ph.

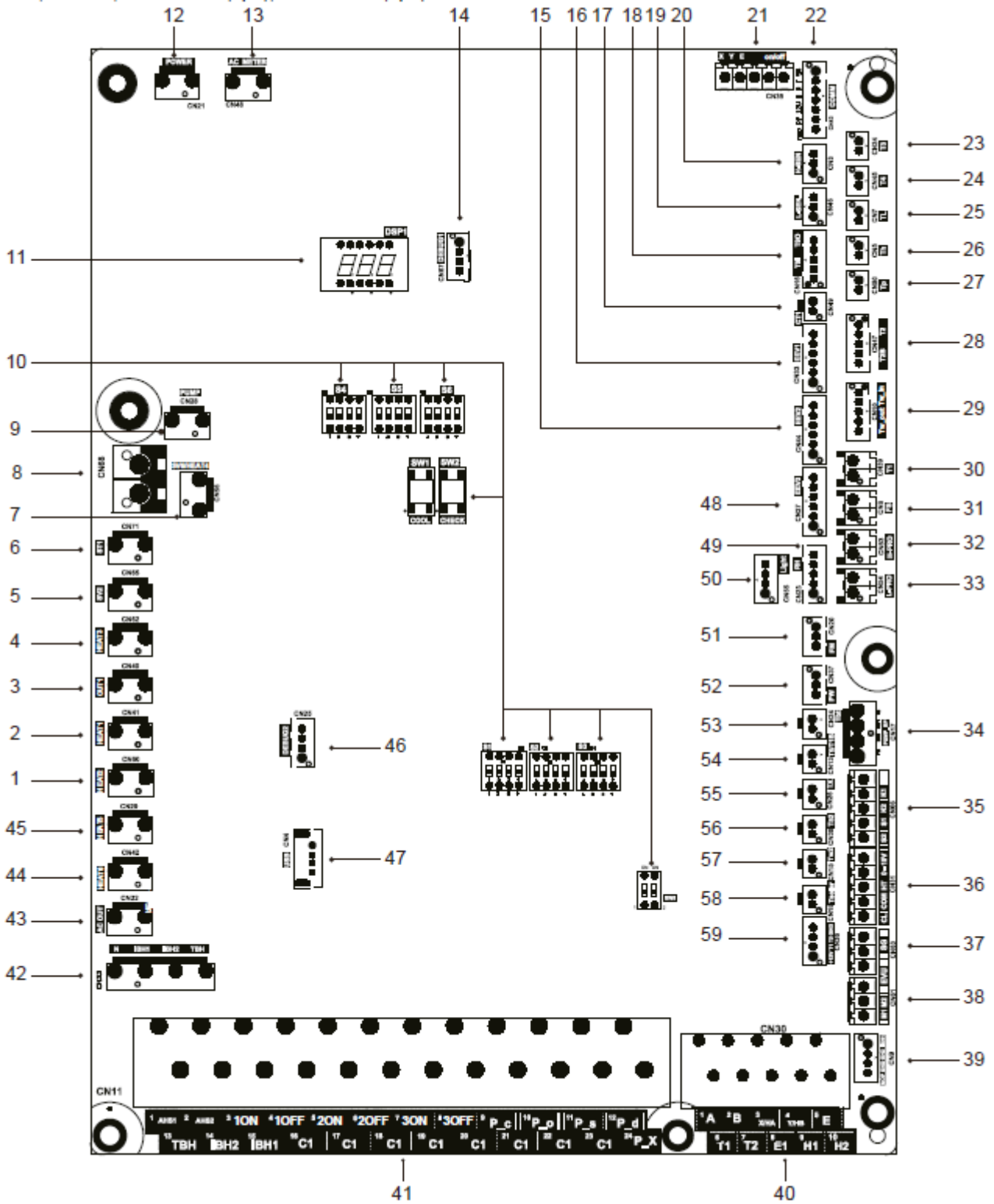



N°	Port	Code	Assembly unit		N°	Port	Code	Assembly unit	
1	CN60	HEAT2	Reserved		37	CN63	SG	Port for smart grid (grid signal)	0-12VDC
2	CN41	HEAT1	Reserved	230VAC			EVU	Port for smart grid (photovoltaic signal)	0-12VDC
3	CN40	OUT1	OUT1	230VAC	38	CN61	M1M2	Port for remote switch	0-12VDC
4	CN62	HEAT3	Port for crankcase heating tape	230VAC	39	CN9	/	Control port for internal backup heater	0-5VDC
5	CN65	SV2	Reserved		40	CN30	1, 2	Port for additional heat source	
6	CN71	ST1	Port for 4-way valve	230VAC			3, 4	Port for communication with the wired controller	
7	CN56	/	Port for the heating tape of drainage outlet	230VAC			6, 7	Port for thermostat transfer board	
8	CN68	/	Port for the heating tape of drainage outlet	230VAC			9, 10	Port for machine Cascade	
9	CN28	PUMP	Port for variable speed pump power input		41	CN11	1-2	Port for additional heat source	230VAC
10	/	/	Dip switch				3-4-17	Port for SV1(3-way valve)	230VAC
11	DSP1	/	Digital display				5-6-18	Port for SV2(3-way valve)	230VAC
12	CN21	POWER	Port for power supply	230VAC			7-8-19	Port for SV3(3-way valve)	230VAC
13	CN48	AC METER	Reserved				9-20	Port for zone 2 pump	230VAC
14	CN67	DEBUG1	Port for IC programming				10-21	Port for outside circulation pump	230VAC
15	CN44	EEV2	Port for electrical expansion valve2				11-22	Port for solar energy pump	230VAC
16	CN33	EEV1	Port for electrical expansion valve1(Reserved)	0-12VDC			12-23	Port for DHW pipe pump	230VAC
17	CN49	CT1	Port for current transformer(Reserved)				13-16	Control port for tank booster heater	230VAC
18	CN16	T9O/T9I	Reserved				14-16	Control port for internal backup heater 1	230VAC
19	CN46	L-SEN	Port for low pressure sensor	0-5VDC	15-17	Control port for internal backup heater 2	230VAC		
20	CN3	H-SEN	Port for high pressure sensor	0-5VDC	24-23	Reserved	230VAC		
21	CN35	RS485	Reserved	0-5VDC	42	CN22	IBH1	Control port for internal backup heater 1	230VAC
		ON/OFF	Reserved	0-5VDC			IBH2	Control port for internal backup heater 2	230VAC
22	CN43	COMM	Port for communication with Inverter module	0-5VDC			TBH	Control port for tank booster heater	230VAC
23	CN34	T3	Port for T3 temp.sensor	0-3.3VDC	43	CN32	AC OUT	Port for transformer power input	230VAC
24	CN45	T4	Port for T4 temp.sensor	0-3.3VDC	44	CN42	HEAT6	Port for anti-freeze electric heating tape(internal)	230VAC
25	CN7	TL	Port for TL temp.sensor	0-3.3VDC	45	CN29	HEAT5	Port for anti-freeze electric heating tape(internal)	230VAC
26	CN5	Th	Port for Th temp.sensor	0-3.3VDC	46	CN25	DEBUG2	Port for IC programming	
27	CN50	Tp	Port for Tp temp.sensor	0-3.3VDC	47	CN4	USB	Port for USB programming	
28	CN47	T2	Port for refrigerant liquid side temperature (heating mode)	0-5VDC	48	CN27	EEV3	Port for electrical expansion valve3(Reserved)	
		T2B	Port for temperature sensors of refrigerant gas side temperature (cooling mode)	0-5VDC	49	CN23	RH	Port for humidity sensor	
29	CN10	TW_in	Port for temperature sensors of inlet water temperature of plate heat exchanger	0-5VDC	50	CN55	LIGHT	Port for breathing light	
		TW_out	Port for temperature sensors of outlet water temperature of plate heat exchanger	0-5VDC	51	CN20	FM	Reserved	0-5VDC
30	CN39	T1	Port for temperature sensors of final outlet water temperature	0-5VDC	52	CN37	PW	Port for temperature sensor of water pressure	0-5VDC
31	CN8	FS	Port for flow switch	0-12VDC	53	CN24	Tbt	Port for temperature sensor of balance tank	0-5VDC
32	CN53	H-PRO	Port for high pressure switch(Reserved)		54	CN13	T5/T1B	Port for domestic hot water tank temp. sensor	0-5VDC
33	CN54	L-PRO	Port for low pressure switch(Reserved)		55	CN26	TX	Reserved	
34	CN17	PUMP_BP	Port for variable speed pump communication	0-5VDC	56	CN38	T52	Port for temperature sensor of balance tank 2	0-5VDC
35	CN66	K1, K2	Port for high pressure switch	0-5VDC	57	CN15	Tw2	Port for outlet water for zone 2 temp. sensor	0-5VDC
		S1, S2	Port for high pressure switch	0-5VDC	58	CN18	Tsolar	Port for solar panel temp sensor	0-5VDC
36	CN31	0-10V	Output port for 0-10V	0-5VDC	59	CN36	/	Port for thermostat transfer board	0-12VDC
		HT	Control port for room thermostat (heating mode)	0-5VDC					
		COM	Power port for room thermostat	0-5VDC					
		CL	Control port for room thermostat (cooling mode)	0-5VDC					

## 8.6. Connection of Other Components

The port provides the control signal to the load. Two kinds of control signal ports:

- Type 1: dry contactor without voltage.
- Type 2: The port provides the signal with 220 V-240 V~ 50 Hz voltage.

**NOTE**

If the current of load is smaller than 0.2 A, load can connect to the port directly. If the load current is larger than or equal to 0.2 A, it is necessary to connect the AC contactor to the load.

Illustrations below are for 3-phase units. The principle is the same for 1-phase units.

Illustrations below are based on units with a backup heater.

**Type 1**

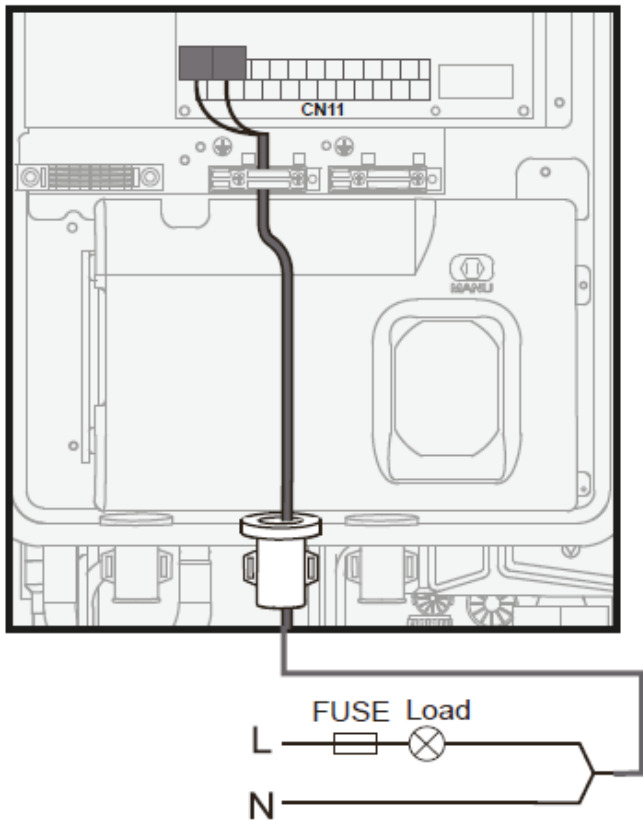

**Type 2**

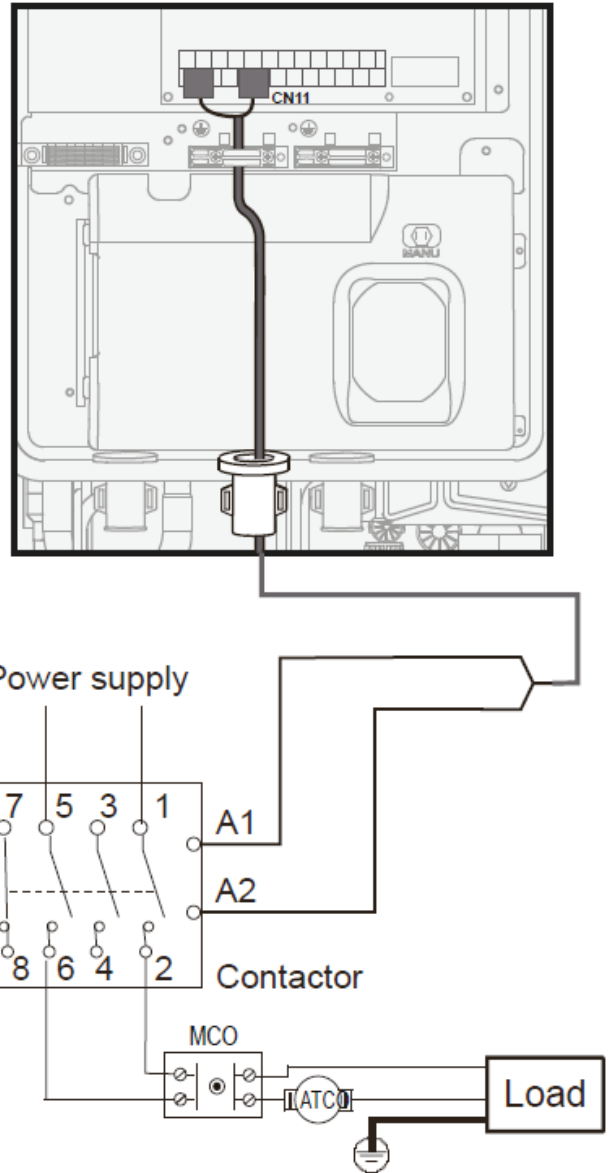

Control signal port of hydraulic module: The CN11 contains terminals for the 3-way valve, pump, booster, and heater, etc.

Connect the cable to an appropriate terminal as shown in the figure and fix the cable reliably.

## 8.6.1. Wiring of additional heat source control (AHS)

If you want to install the unit with a gas boiler or oil boiler, you need to control it.

Please note that you cannot have AHS & IBH at the same time. If you activate the AHS, you need to deactivate the IBH.

L-N Voltage	220-240 VAC
Maximum running current (A)	0.2
Minimum wire size (mm <sup>2</sup> )	0.75
Control port signal type	Type 1

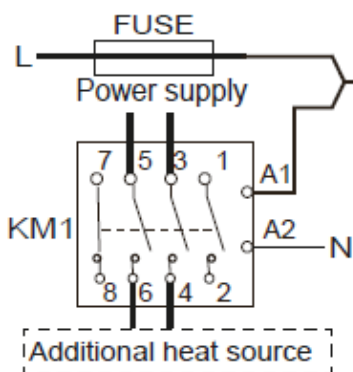
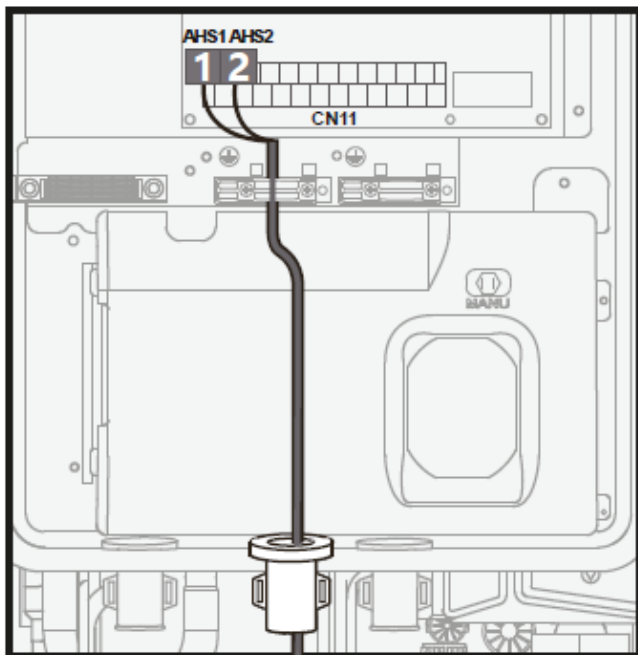

## 8.6.2. Wiring of 3-way valves SV1, SV2 and SV3

SV1 is controlling the change between Heating/Cooling and Domestic Hot Water mode.

SV2 is controlling the change between Heating & Cooling.

SV3 is controlling the mixing valve for the Zone2 temperature control.

L-N Voltage	220-240 VAC
Maximum running current (A)	0.2
Minimum wire size (mm <sup>2</sup> )	0.75
Control port signal type	Type 2

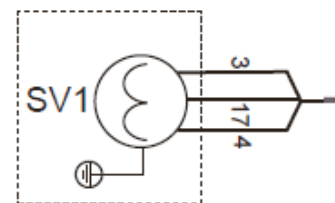
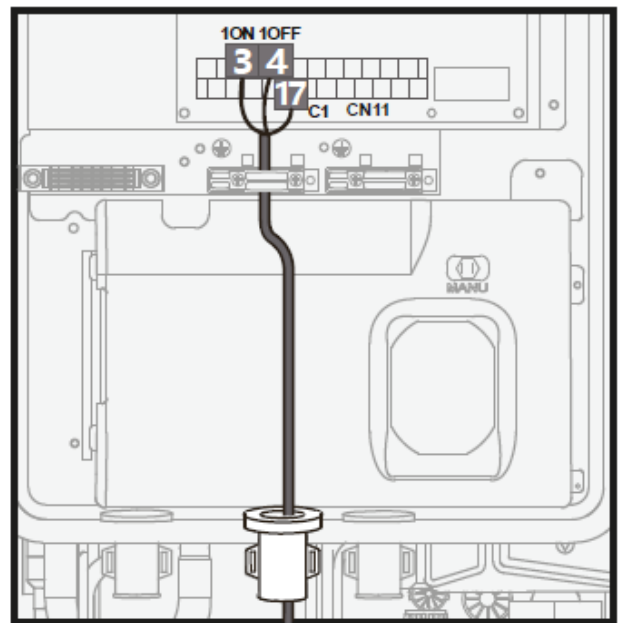

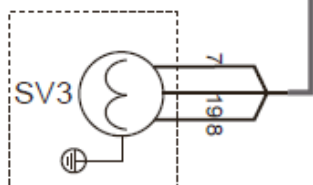
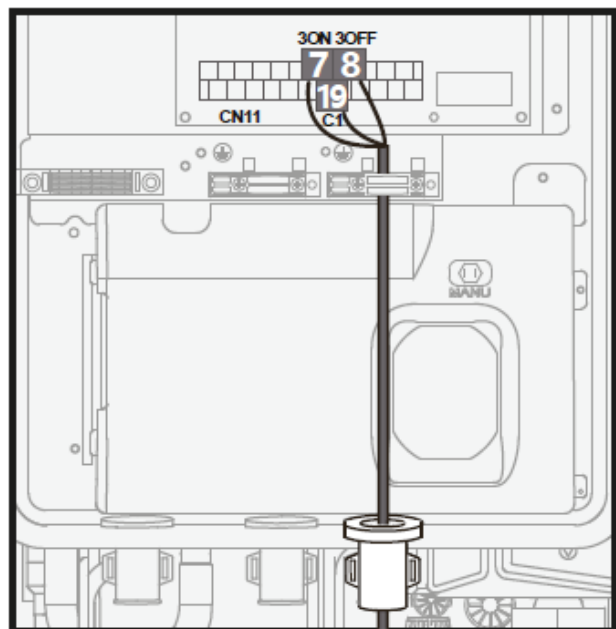
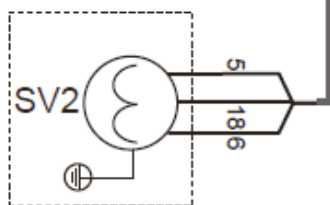
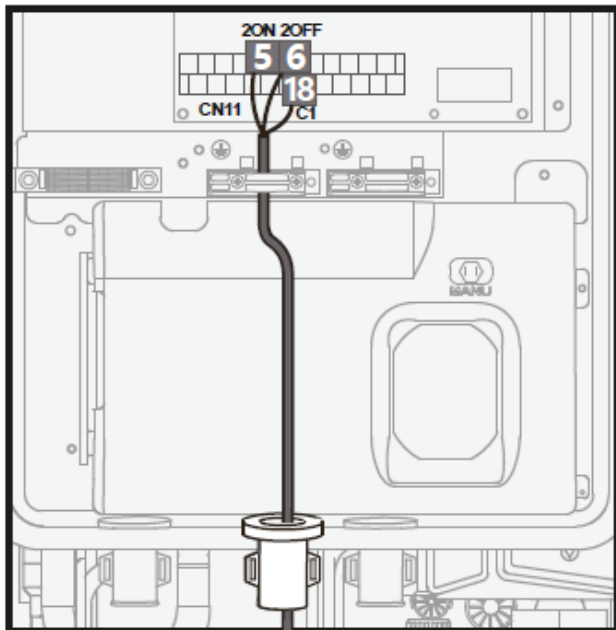

### 8.6.3. Wiring of additional pumps

P\_o is the additional circulation pump. It is controlling Zone 1.

P\_c is the additional circulation pump for the Zone 2.

P\_s is the circulation pump for the solar panel.

P\_d is the recirculation pump for the Domestic Hot Water.

L-N Voltage	220-240 VAC
Maximum running current (A)	0.2
Minimum wire size (mm <sup>2</sup> )	0.75
Control port signal type	Type 2

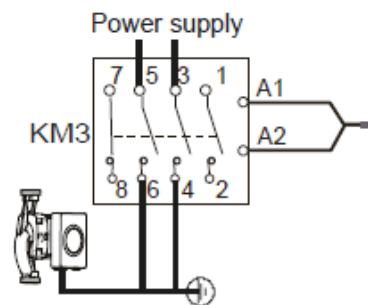
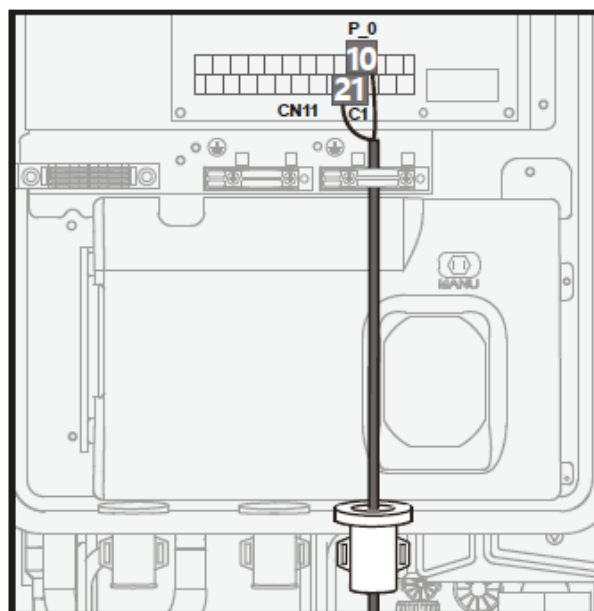

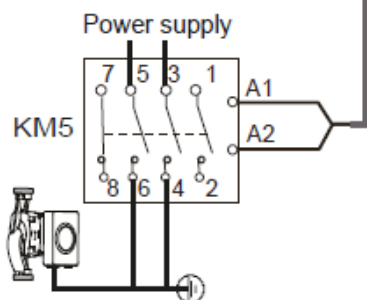
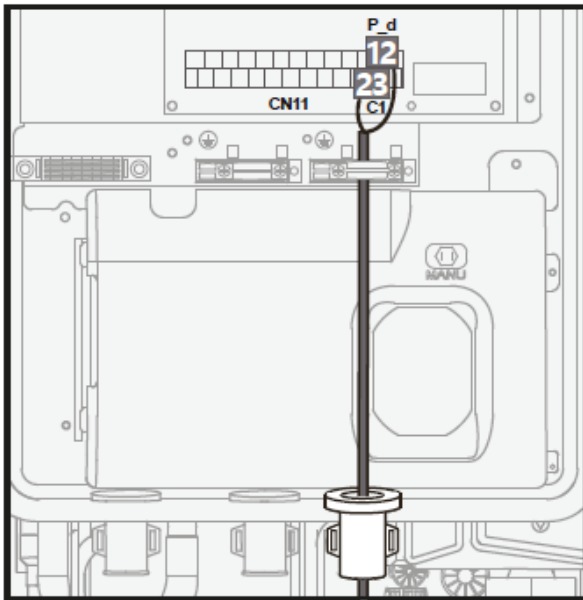
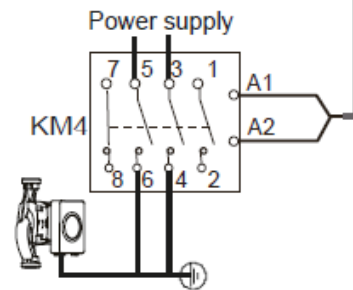
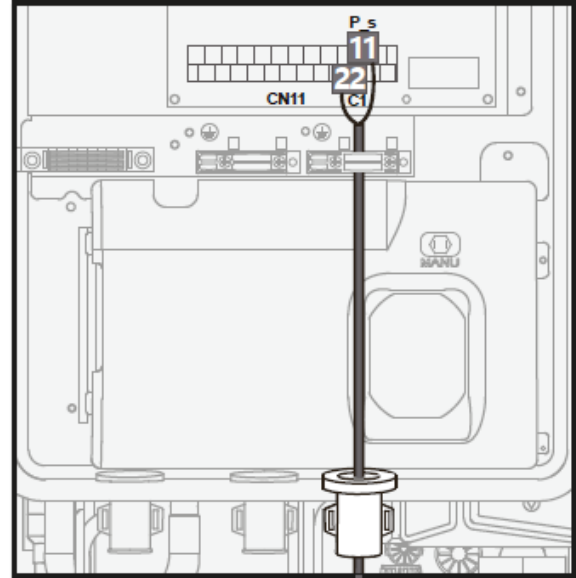
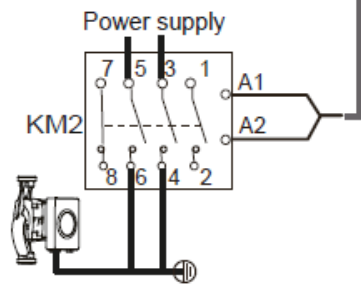
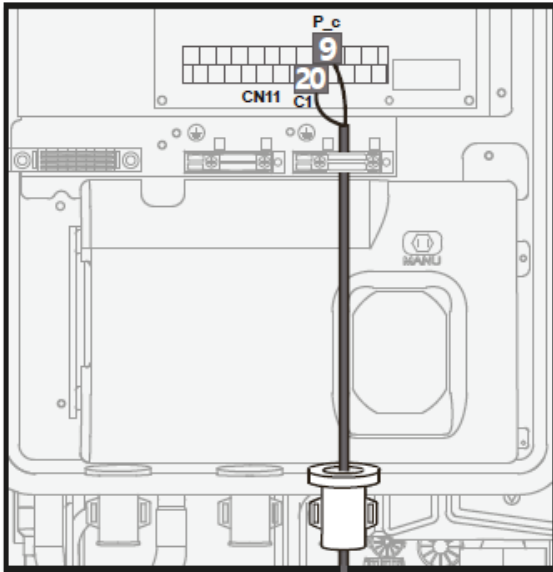

## 8.6.4. Wiring of tank booster heater (TBH)

If you install a Domestic Water Tank, please install also a Tank Booster Heater (TBH). This will allow the heat pump to control the disinfection mode inside the tank. The heat pump only control the ON/OFF of the TBH, it cannot provide the power.

L-N Voltage	220-240 VAC
Maximum running current (A)	0.2
Minimum wire size (mm <sup>2</sup> )	0.75
Control port signal type	Type 1

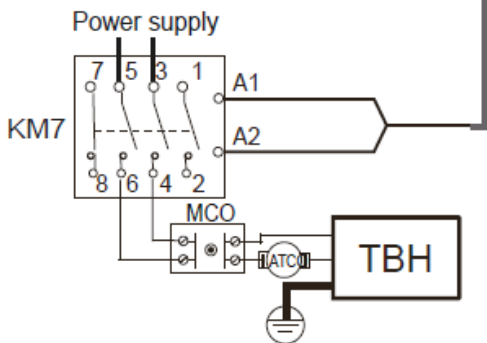
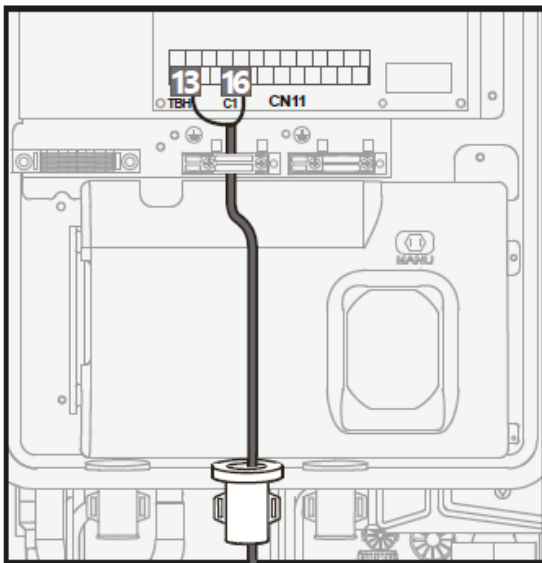

### NOTE

MCO: Manual reset thermal protector  
ATC: Auto reset thermal protector

## 8.6.5. Wiring of alarm or defrost run (P\_x)

If needed, you can connect a alarm output or defrost output to this port. You can change on the remote controller between Alarm or Defrost.

So if the unit is in Defrost mode, the heat pump will activate the port.

Or if the heat pump is in fault, it will activate the port.

L-N Voltage	220-240 VAC
Maximum running current (A)	0.2
Minimum wire size (mm <sup>2</sup> )	0.75
Control port signal type	Type 2

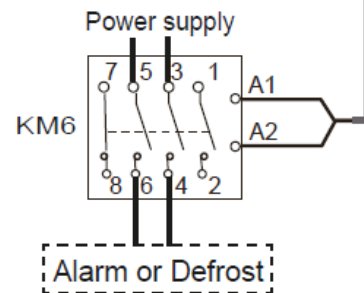
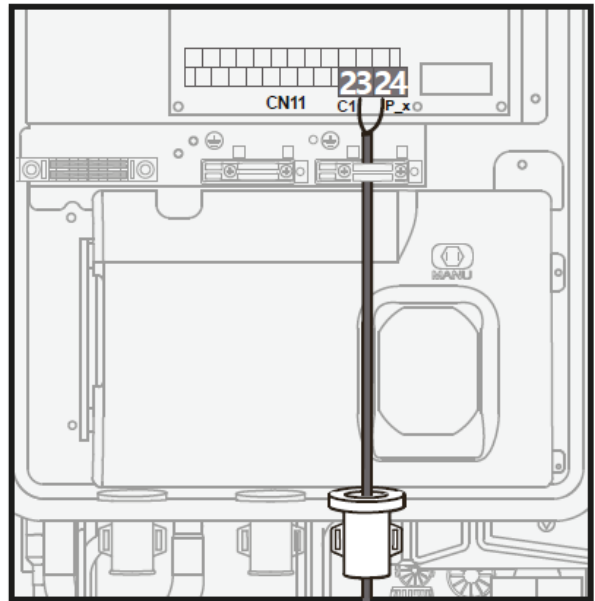

## 8.6.6. Wiring of room thermostat (RT)

Room thermostat (low voltage): "POWER IN" provides the voltage to the RT.

### NOTE

The room thermostat must be low-voltage. (12V)

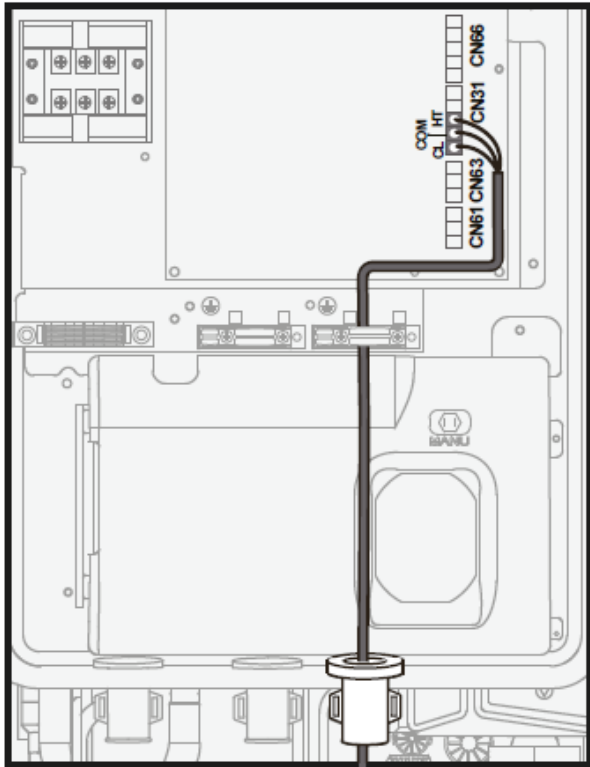

Method A  
(Mode setting control)

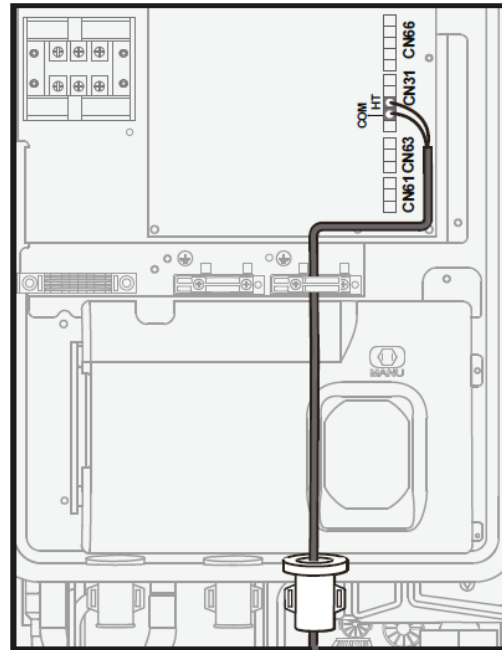
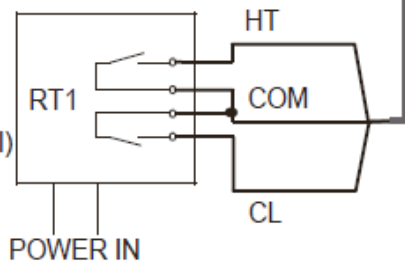

Method B  
(Single-zone control)

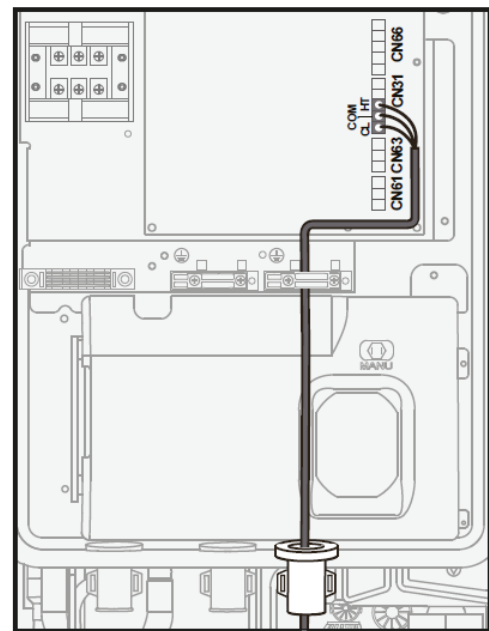
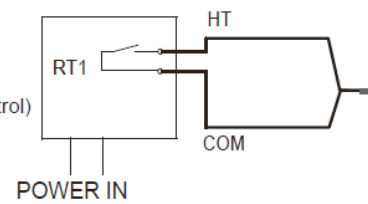

Method C  
(Double-zone control)

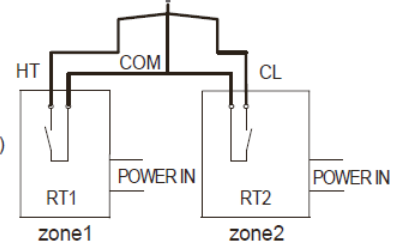

The thermostat cable can be connected in three ways (as described in the figures above) and the specific connection method depends on the application.

## Method A (Mode setting control)

RT can control heating and cooling individually, like the controller for 4-pipe FCU. When the hydraulic module is connected with the external temperature controller, ROOM THERMOSTAT is set to MODE SET on the user interface:

A.1 When the unit detects a voltage of 230 VAC between C and L1, it operates in cooling mode.

A.2 When the unit detects a voltage of 230 VAC between H and L1, it operates in heating mode.

A.3 When the unit detects a voltage of 0 VAC for both sides (C-L1 and H-L1), it stops working for space heating or cooling.

A.4 When the unit detects a voltage of 230 VAC for both sides (C-L1 and H-L1), it operates in cooling mode.

## Method B (single-zone control)

RT provides the switch signal to the unit. ROOM THERMOSTAT is set to ONE ZONE on the user interface:

B.1 When the unit detects a voltage of 230 VAC between H and L1, it turns on.

B.2 When the unit detects a voltage of 0 VAC between H and L1, it turns off.

## Method C (double-zone control)

The hydraulic module is connected with two room thermostats, and ROOM THERMOSTAT is set to DOUBLE ZONE on the user interface:

C.1 When the unit detects a voltage of 230 VAC between H and L1, zone1 turns on. When the unit detects a voltage of 0 VAC between H and L1, zone1 turns off.

C.2 When the unit detects a voltage of 230 VAC between C and L1, zone2 turns on according to the climate temp curve. When the unit detects a voltage of 0 V between C and L1, zone2 turns off.

C.3 When the voltage between H-L1 and C-L1 is detected as 0VAC, the unit turns off.

C.4 When the voltage between H-L1 and C-L1 is detected as 230 VAC, both zone1 and zone2 turn on.

### NOTE

The wiring of the thermostat should correspond to the settings of the user interface. Refer to 7.6.7 "Room Thermostat".

- Power supply of the device and room thermostat must be connected to the same neutral line.
- When ROOM THERMOSTAT is not set to NON, the indoor temperature sensor Ta cannot be set to VALID.
- Zone 2 can only operate in heating mode. When cooling mode is set on the user interface and zone 1 is OFF, "CL" in Zone 2 closes, and system still remains 'OFF'. For installation, the wiring of thermostats for Zone 1 and Zone 2 must be correct.

## 8.6.7. Wiring of solar energy input signal (low voltage)

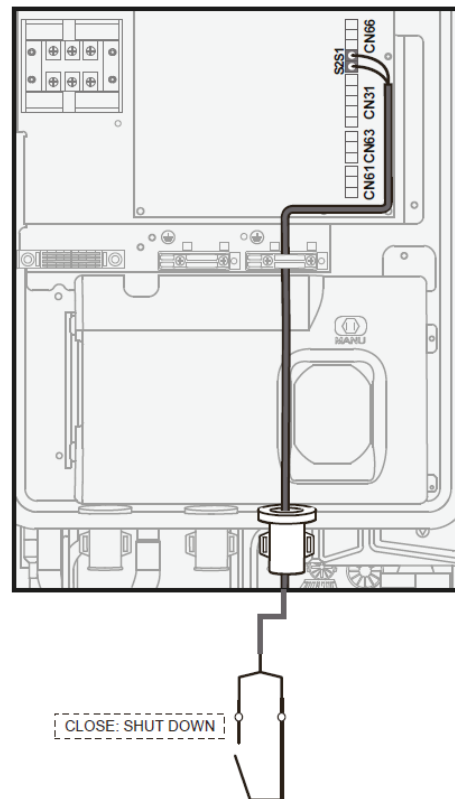

## 8.6.8. Wiring of remote shutdown

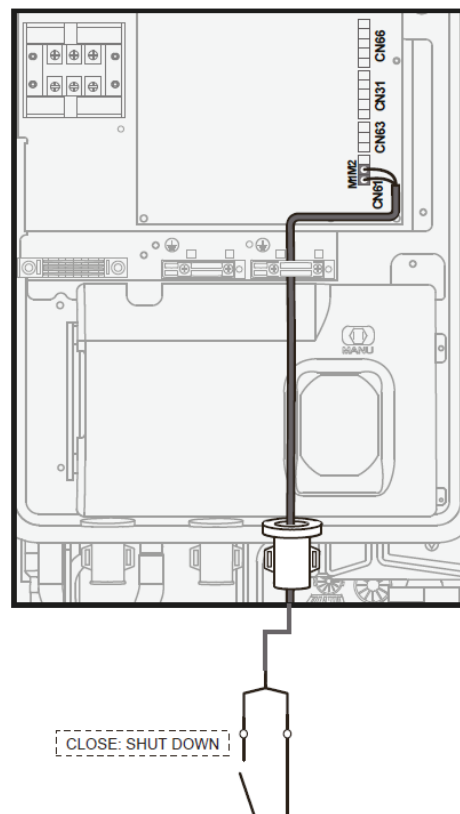



## 8.6.9. Wiring of smart grid

The unit has a smart grid feature, and there are two ports on the PCB to connect SG signals and EVU signals as below:

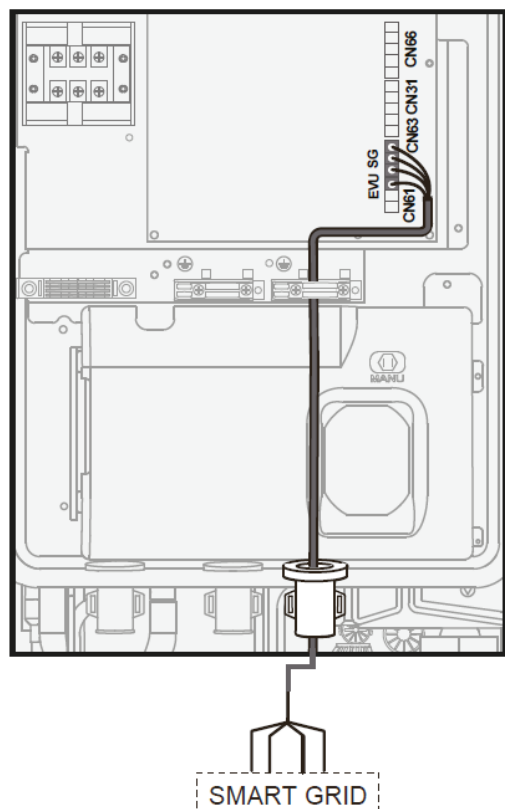

### 1) SG=ON, EVU=ON.

If DHW mode is set available:

- The heat pump will operate in DHW mode firstly.
- When TBH is set available, if T5 is smaller than 69°C, the TBH will be turned on forcibly (The heat pump and TBH can operate at the same time.); if T5 is larger than or equal to 70°C, the TBH will be turned off. (DHW:

•Domestic Hot Water; T5S is the set temperature of the water tank.)

- When TBH is set unavailable and IBH is set available for DHW mode, if T5 is smaller than 59°C, the IBH will be turned on forcibly (The heat pump and TBH can operate at the same time.); if T5 is larger than or equal to 60°C, the IBH will be turned off.

### 2) SG=OFF, EVU=ON.

If DHW mode is set available and DHW mode is set to ON:

- The heat pump will operate in DHW mode firstly.
- When TBH is set available and DHW mode is set ON, if T5 is smaller than T5S-2, the TBH will be turned on (The heat pump and IBH can operate at the same time.); If T5 is larger than or equal to T5S+3, the TBH will be turned off.

- When TBH is set unavailable and IBH is set available for DHW mode, if T5 is smaller than T5S-dT5\_ON, the IBH will be turned on (The heat pump and IBH can operate at the same time.); If T5 is larger than

or equal to Min (T5S+3,60), the IBH will be turned off.

### 3) SG=OFF, EVU=OFF.

The unit will operate properly.

### 4) SG=ON, EVU=OFF.

The heat pump, IBH, and TBH will be turned off immediately.

## 8.7.Cascade Function

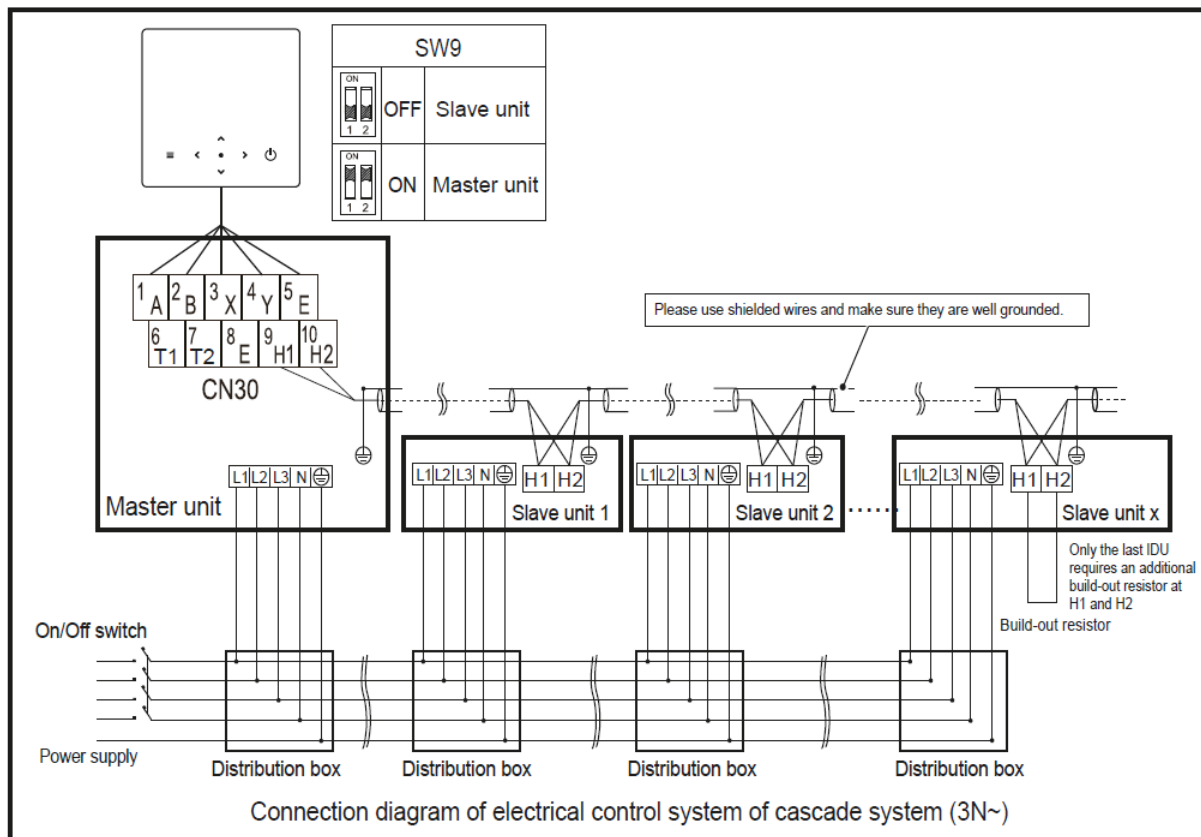
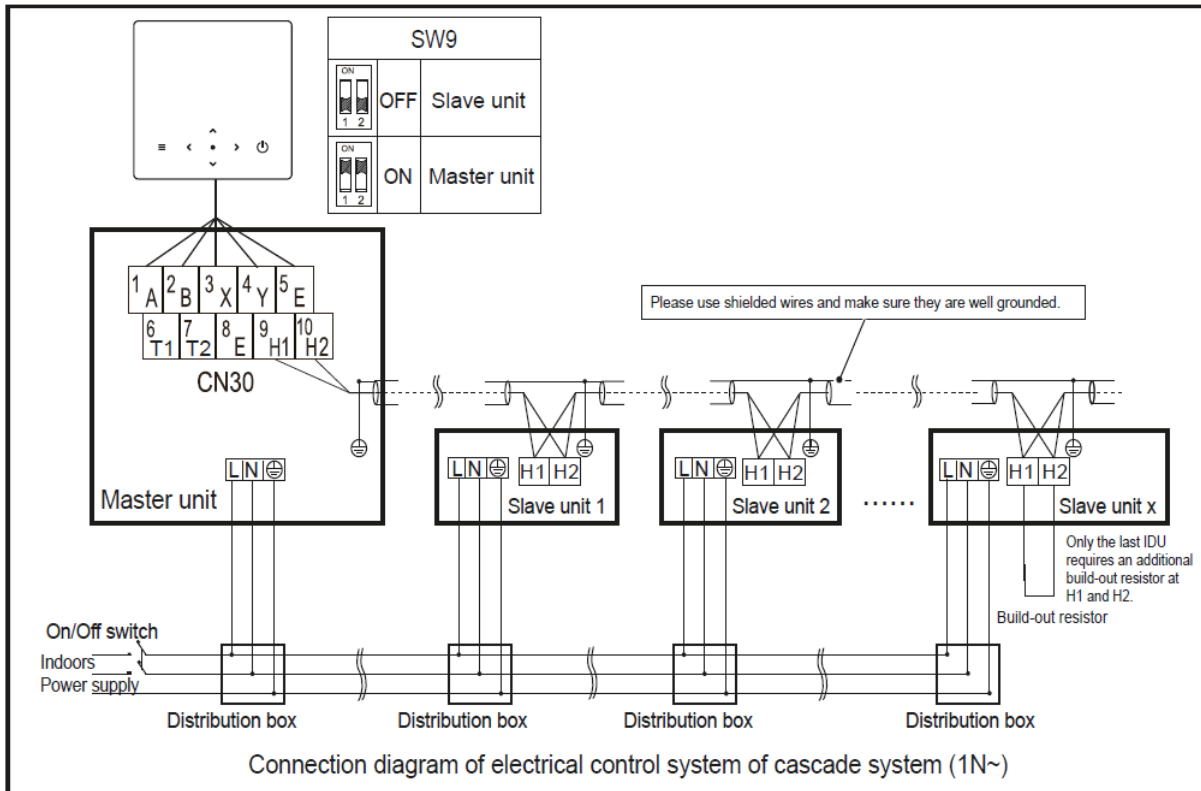

### CAUTION

1. The cascade function of the system supports up to 6 units.
2. To ensure successful automatic addressing, all units must be connected to the same power supply and powered on uniformly.

3. Only the master unit can connect with the controller, and the SW9 of the master unit must be switched to "on". Slave units cannot connect with the controller.
4. Please use shielded wires and make sure they are well grounded.

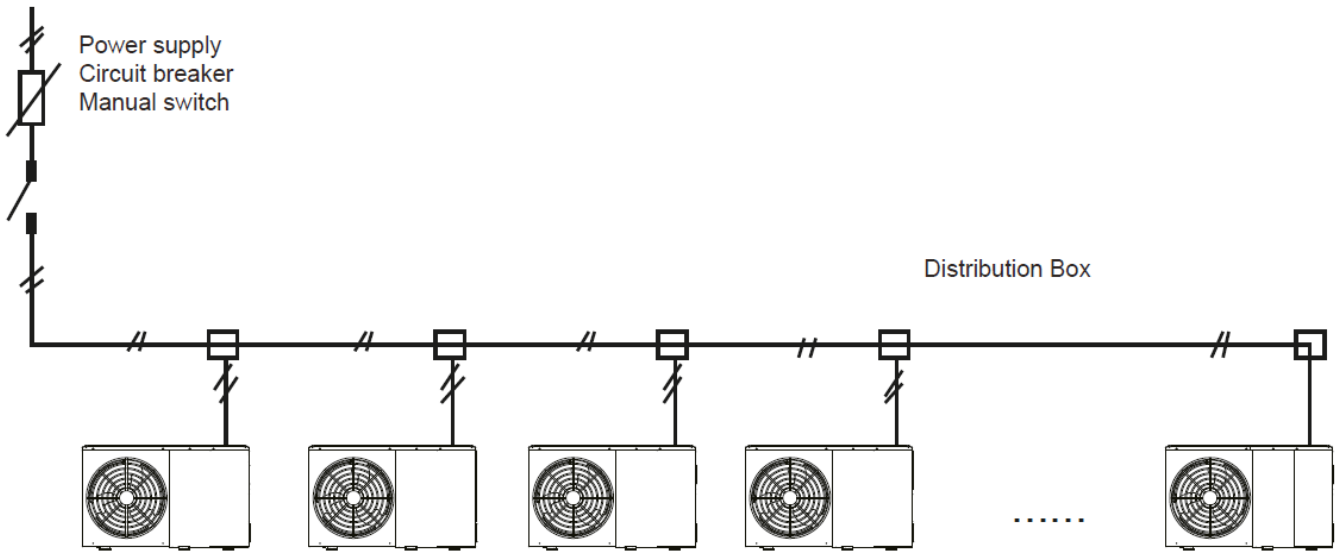

## 8.8.Connection for Other Optional Components

### 8.8.1.Wiring of drainage pipe heating tape

The maximum power is 100W.

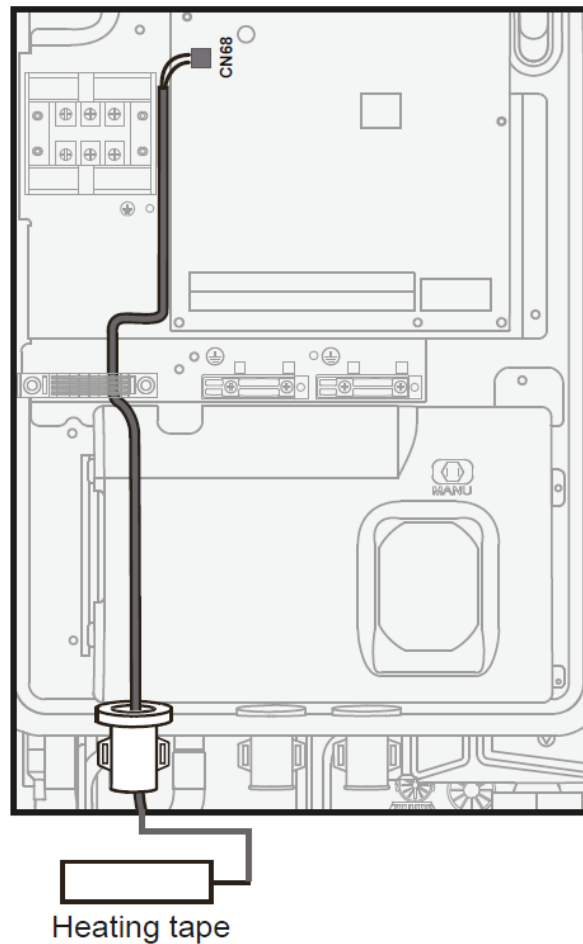

**NOTE**

Use tie wraps

After wiring, the sleeve should be fastened with a tie wrap (accessory)

## 9. INSTALLATION OF WIRED CONTROLLER

### CAUTION

- The general instructions on wiring in previous chapters should be observed.
- The wired controller must be installed indoors and kept away from direct sunlight.
- Keep the wired controller away from any ignition source, flammable gas, oil, water vapor, and sulfide gas.
- To avoid electromagnetic disturbance, keep the wired controller at a proper distance from electric appliances, such as lamps.
- The circuit of the remote wired controller is a low-voltage circuit. Never connect it with a standard 220 V/380 V circuit or place it into a same wiring tube with the circuit.
- Use a terminal connection block to extend the signal wire if necessary.
- Do not use a megger to check insulation of the signal wire upon completion of connection.

### 9.1. Materials for Installation

Verify that the accessory bag contains the following items:

N°	Name	Qty	Remarks
1	Wired controller	1	
2	Round head screw, ST4 x 20	4	For mounting on a wall
3	Cross round head mounting screw	2	For mounting on an 86-type box
4	Phillips head screw, M4 x 25	2	For mounting on an 86-type box
5	Plastic support bar	4	For mounting on a wall

### 9.2. Dimensions

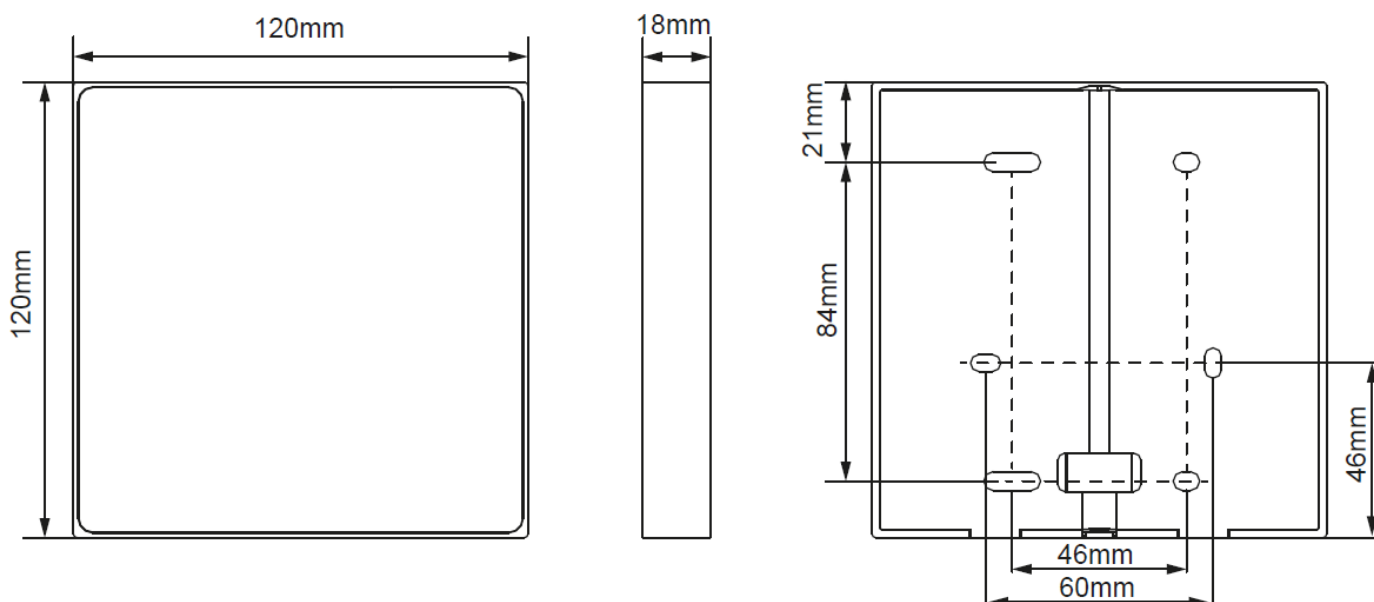

## 9.3.Wiring

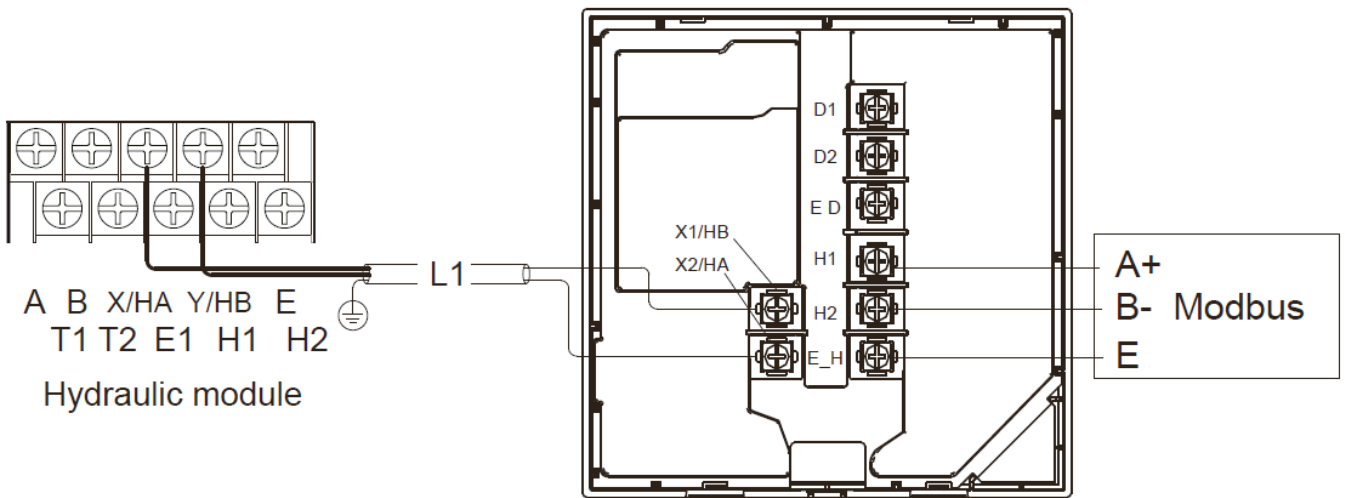

Input voltage (HA/HB)	18 VDC
Wire size	0.75 mm <sup>2</sup>
Wire type	2-core shielded twisted pair cable
Wire length	L1<50 m

The maximum length of the communication wire between the unit and the controller is 50 m.

### Route

Bottom-side wiring out

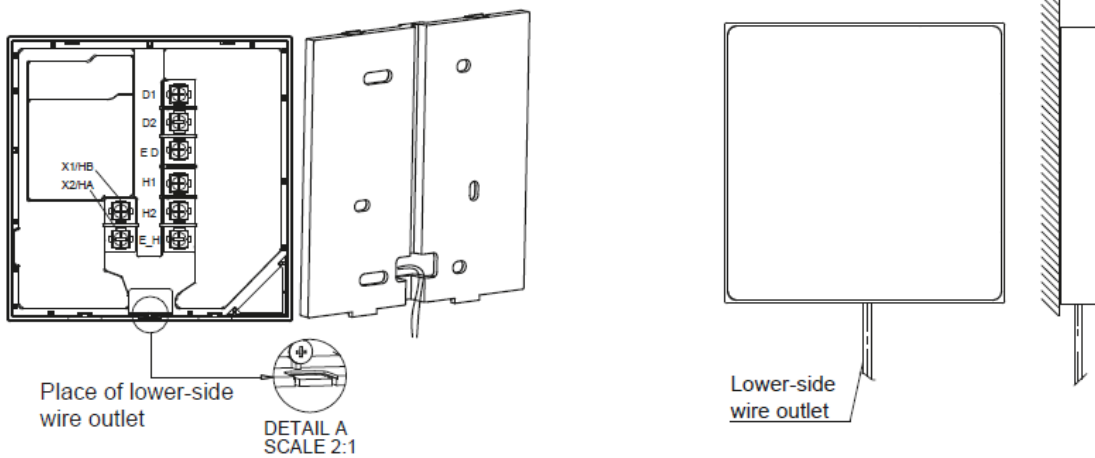

Inside wall wiring (with an 86-type box)

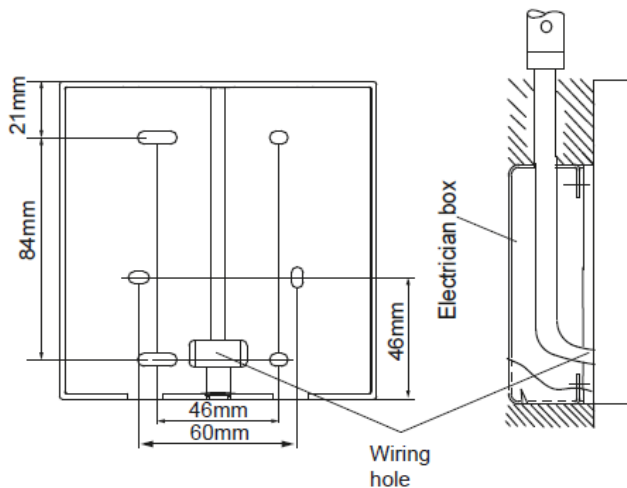

Inside wall wiring (without an 86-type box)

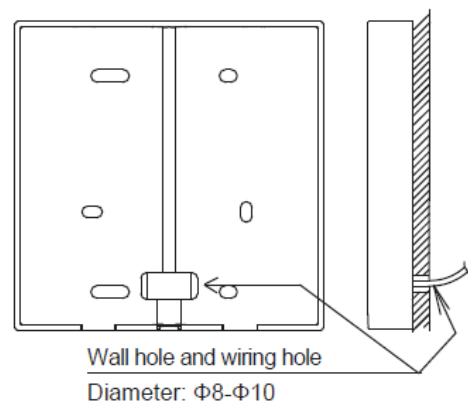

## 9.4.Mounting

### NOTE

Only wall-mount the wired controller, instead of embedded, otherwise maintenance will not be possible.

#### Mounting on a wall (without an 86-type box)

Directly install the back cover on the wall with four ST4 x 20 screws.

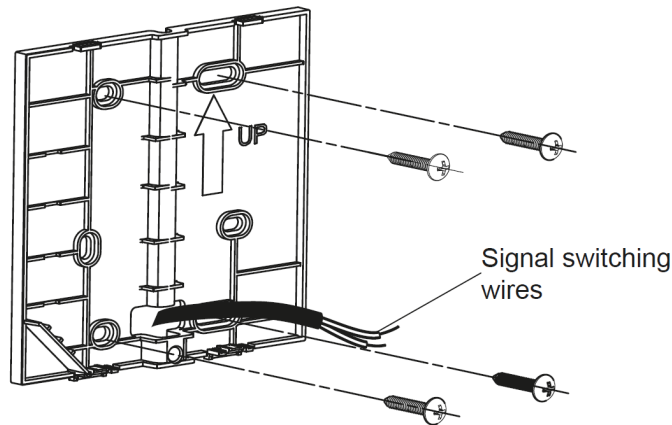

#### Mounting on a wall (with an 86-type box)

Install the back cover on an 86-type box with two M4 x 25 screws, and fixing the box on the wall with two ST4 x 20 screws.

Adjust the length of the plastic bolt in the accessory box to make it suitable for installation.

Fix the wired controller's bottom cover to the wall through the screw bar by using cross head screws. Make sure the bottom cover is set flush on the wall.

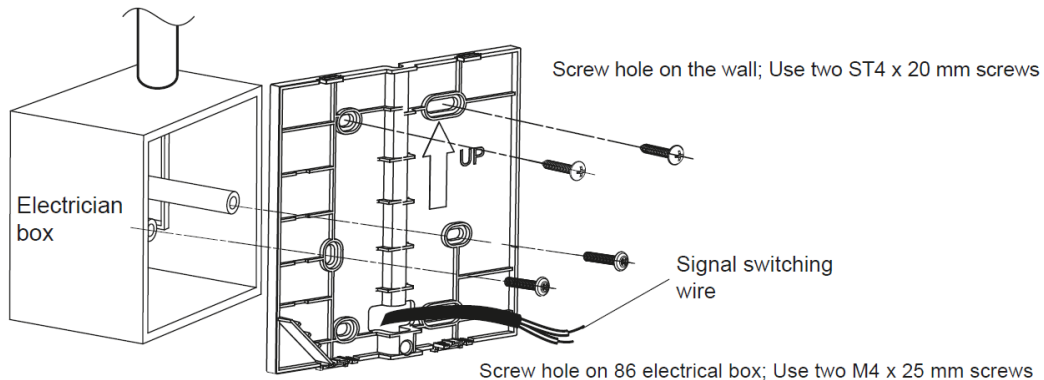

Buckle the front cover, and fit the front cover to the back cover properly, leaving the wire unclamped during the installation.

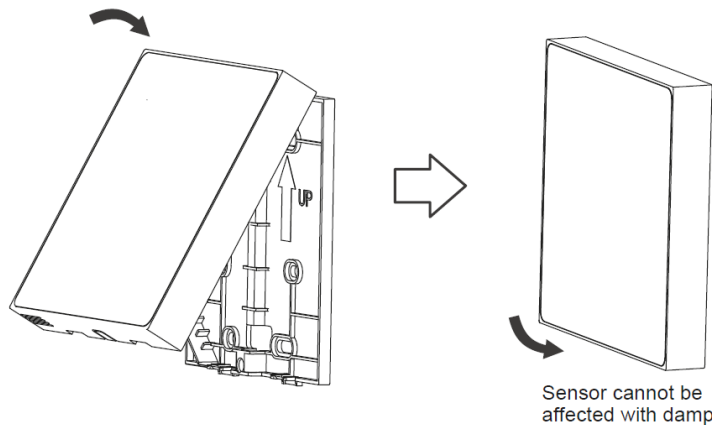

### NOTE

To prevent water from entering the remote wired controller, use traps and plugs to seal the wire connections during wiring.

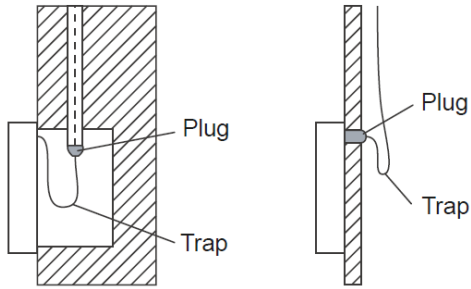

Avoid the water enter into the wired remote controller, use trap and putty to seal the connectors of wires during wiring installation.

### NOTE

Over-tightening the screw can cause deformation of the back cover.

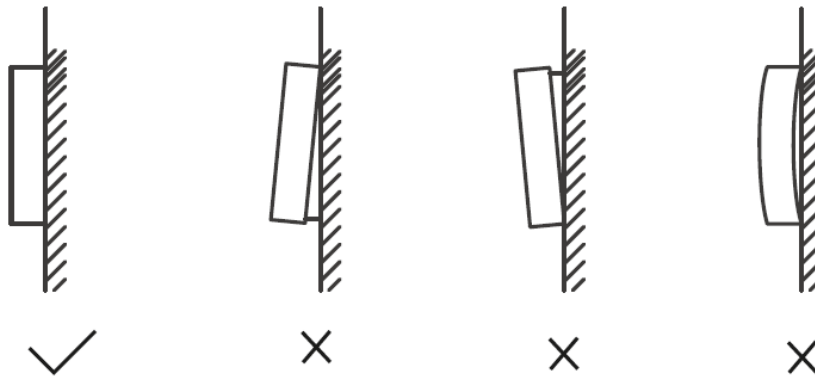

## 10.COMPLETION OF INSTALLATION

### DANGER

Risk of electrocution.  
Risk of burning.

### NOTE

The illustrations below are for 8-16 kW units. The principle is the same for 4-6 kW units.

Tightening torque 4.1 N·m

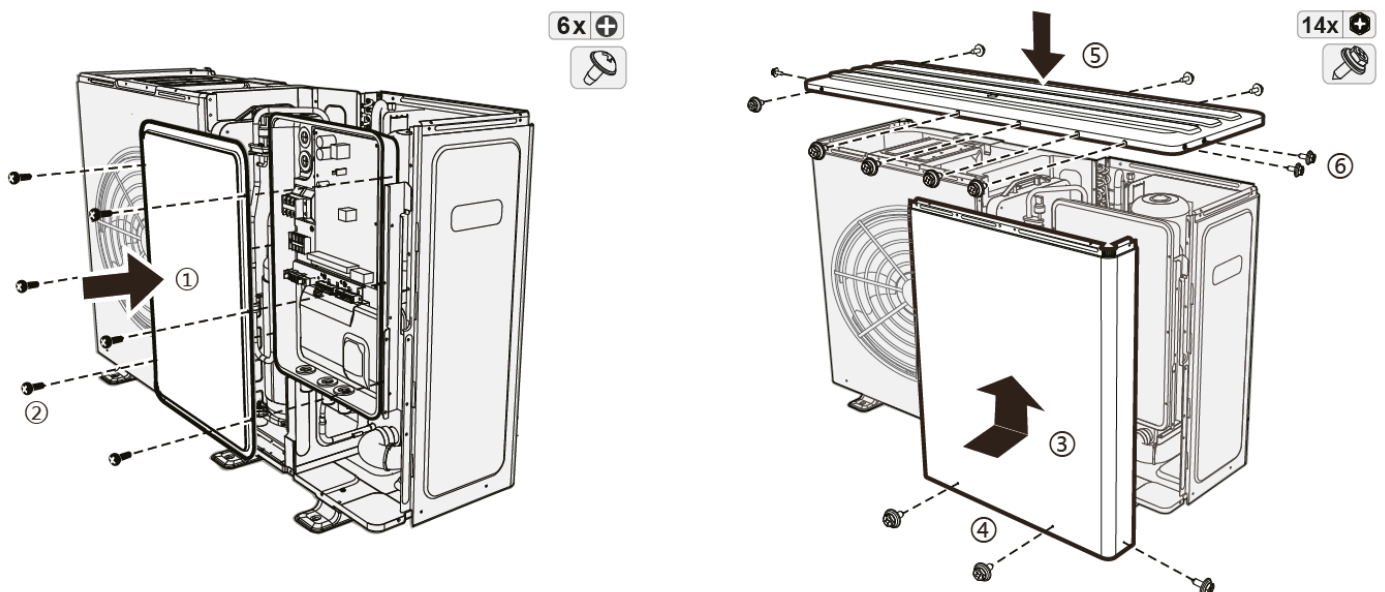

## 11.CONFIGURATION

The unit should be configured by an authorized installer to match the installation environment (outdoor climate, installed options, etc.) and meet the user demand.  
Follow the instructions below for the next step.

### 11.1.Check Before Configuration

Before powering on the unit, check the following items:

N°	CHECK	Description
1		<b>Field wiring:</b> Make sure all wiring connections observe the instructions mentioned in the 8. Electrical installation
2		<b>Fuses, circuit breakers, or protection devices:</b> Check the size and type according to the instructions mentioned in the 8.4 Electrical wiring guidelines. Make sure that no fuses or protection devices have been bypassed.
3		<b>Backup heater's circuit breaker:</b> Ensure the backup heater's circuit breaker in the switch box is closed (It varies with the backup heater type). Refer to the wiring diagram.
4		<b>Booster heater's circuit breaker:</b> Ensure the booster heater's circuit breaker is closed (applicable only to units with an optional domestic hot water tank).
5		<b>Internal wiring:</b> Check the wiring and connections inside the switch box for loose or damaged parts, including earth wiring.
6		<b>Mounting:</b> Check and ensure that the unit and the water loop system are properly mounted to avoid water leakage, abnormal noises and vibrations during the unit startup.
7		<b>Damaged equipment:</b> Check the components and piping inside the unit for any damage or deformation.
8		<b>Refrigerant leak:</b> Check the inside of the unit for any refrigerant leakage. In case of refrigerant leakage, follow the relevant content in the "Safety Precautions".
9		<b>Power supply voltage:</b> Check the voltage of the power supply. The voltage must be consistent with the voltage on the identification label of the unit.
10		<b>Air vent valve:</b> Make sure the air vent valve is open (at least 2 turns).
11		<b>Shut-off valve:</b> Make sure that the shut-off valve is fully open.
12		<b>Sheet metal:</b> Make sure all the sheet metal of the unit is mounted properly.

After powering on the unit, check the following items:

N°	CHECK	Description
13		<b>Upon power-on of the unit, nothing is displayed on the user interface:</b> Check the following abnormalities before diagnosing possible error codes. - Wiring connection issue (power supply or communication signal). - Fuse failure on PCB.
14		<b>Error code "E8" or "E0" is displayed on the user interface:</b> - Residual air exists in the system. - The water level in the system is insufficient. Before starting test run, make sure that the water system and the tank are filled with water, and air is removed. Otherwise, the pump or backup heater (optional) may be damaged.
15		<b>Error code "E2" is displayed on the user interface:</b> - Check the wiring between the wired controller and the unit.
16		<b>Initial start-up at low outdoor ambient temperature:</b> To start the initial start-up in low outdoor ambient temperature, the water has to be heated gradually. Please use the preheating for floor function. (Refer to "SPECIAL FUNCTION" in FOR SERVICEMAN mode)





## 11.2.Configuration

To initialize the unit, a group of advanced settings should be provided by the installer. The advanced settings are accessible in FOR SERVICEMAN mode.

The overall parameters list of the advanced settings can be found in 11.3 Operation Settings.

### How to enter FOR SERVICEMAN mode

Press and hold  and  simultaneously for 3 seconds to enter the authorization page. Enter password 234 and confirm it. Then, the system jumps into the page with a list of advanced settings.

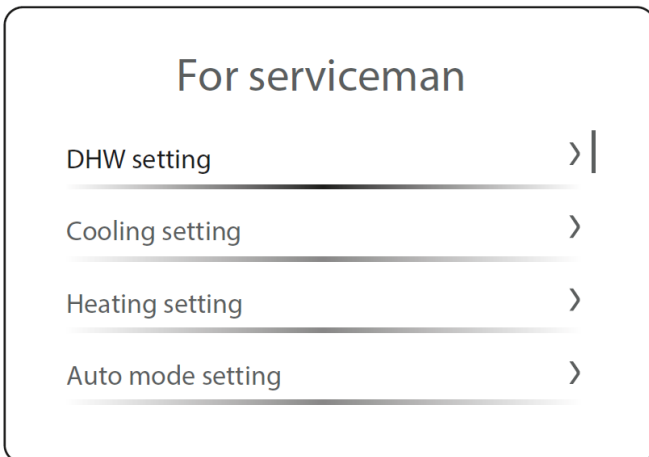
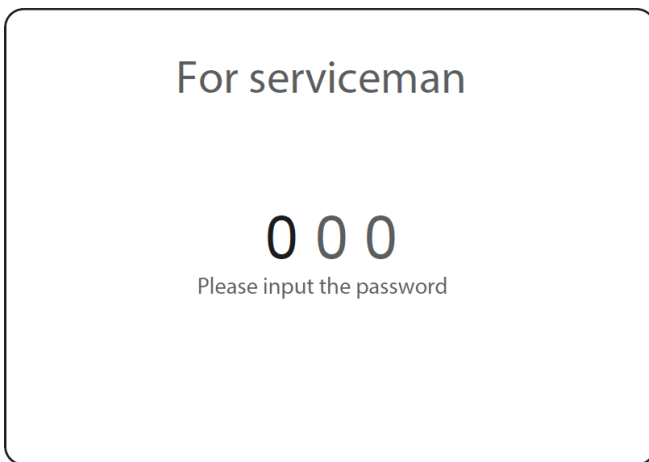

#### NOTE

*It is not recommended to enter "FOR SERVICEMAN" unless you have enough knowledge about the unit and advanced settings.*

### Save the settings and quit FOR SERVICEMAN mode

After all settings are adjusted, press  and the confirmation page pops out. Select Yes and confirm to quit FOR SERVICEMAN mode.

#### NOTE

*The settings are saved automatically after you quit FOR*

#### SERVICEMAN mode.

*Temperature values displayed on the wired controller (user interface) are measured in °C.*

### 11.2.1.DHW setting

Select the target item and enter the setting page. Adjust the launch settings and values based on end user demands.

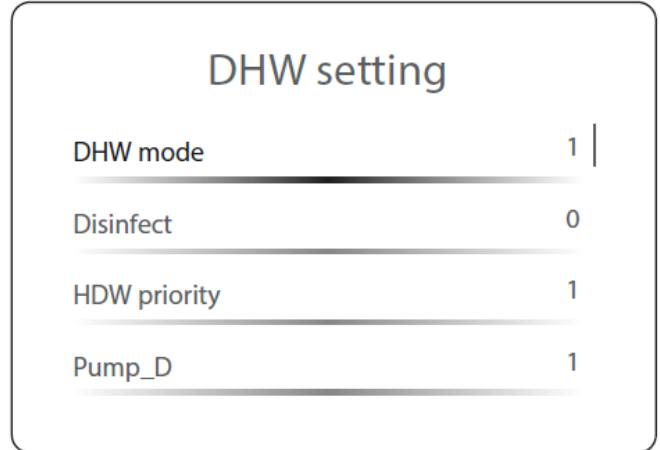

All set parameters and limitations can be found in 11.3 Operation Settings.

### 11.2.2.Cooling setting

Select the target item and enter the setting page. Adjust the launch settings and values based on end user demands.

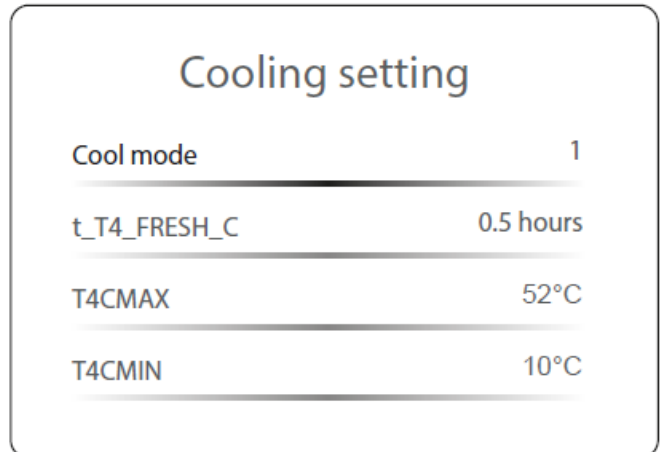

All set parameters and limitations can be found in 11.3 Operation Settings.

## 11.2.3. Heating setting

Select the target item and enter the setting page. Adjust the launch settings and values based on end user demands.

### Heating setting

Heating mode	1
t_T4_FRESH_H	0.5 hours
T4HMAX	25°C
T4HMIN	-15°C

All set parameters and limitations can be found in 11.3 Operation Settings.

Either cooling mode or heating mode must be enabled, and they cannot be both set to NON at the same time.

## 11.2.4. Auto mode setting

Select the target item and enter the setting page. Adjust the launch settings and values based on end user demands.

### Auto mode setting

T4AUTOCMIN	25°C
T4AUTOHMAN	17°C

All set parameters and limitations can be found in 11.3 Operation Settings.

## 11.2.5. Temp. type setting

Select the target item and enter the setting page. Adjust the launch settings and values based on end user demands.

### Temp. type setting

Water flow temp.	1
Room temp.	0
Double zone	1

All set parameters and limitations can be found in 11.3 Operation Settings.

When both DOUBLE ZONE and ROOM TEMP. are enabled, the room temperature control is valid only for Zone 2, and Zone 1 is always under water temperature control.

When Room temp. is enabled, the temperature curve for the room temperature control zone is enforced, and the set temperature of the room temperature control zone can still be adjusted. The type of the temperature curve and the temperature offset can be set. (The unit will stop running if either the set temperature or the temperature curve r is reached).

## 11.2.6. Room thermostat setting

Select the target item and enter the setting page. Adjust the launch settings and values based on end user demands.

### Room thermostat setting

Room thermostat	1
-----------------	---

All set parameters and limitations can be found in 11.3 Operation Settings.

•When Room thermostat is set to any value rather than NON, the setting of Temp. type is invalid.

- When Room thermostat is set to DOUBLE ZONE, DOUBLE ZONE is enabled automatically, and the temperature control mode is water temperature control.

- When Room thermostat is set to MODE SETTING/ONE ZONE, DOUBLE ZONE is disabled automatically, and the temperature control mode is water temperature control.

1) When Room thermostat is set to NON, the room thermostat is invalid.

2) When Room thermostat is set to MODE SETTING, Mode setting priority is visible. The wired controller cannot be used to turn on/off the unit or set the operation mode. Besides the timer related to DHW, all timers in Schedule are invalid. The unit can read the operating status of the unit, and set the temperature if the temperature curve is inactive.

3) When Room thermostat is set to ONE ZONE, the wired controller cannot be used to turn on/off Zone 1. Besides the timer related to DHW, all timers in Schedule are invalid. The unit can read the operating status of the unit, and set the operation mode (excluding Auto mode), and the temperature if the temperature curve is inactive.

4) When Room thermostat is set to DOUBLE ZONE, the wired controller cannot be used to turn on/off the Zone 1 or Zone 2. Besides the timer related to DHW, all timers in Schedule are invalid. The unit can read the operating status of the unit, and set the operation mode (excluding Auto mode), and the temperature if the temperature curve is inactive.

## 11.2.7. Other heat source

Select the target item and enter the setting page. Adjust the launch settings and values based on end user demands.

### Other heat source

IBH function	1	
IBH locate	0	
dT1_IBH_ON	5°C	
t_IBH_DELAY	15 minutes	

All set parameters and limitations can be found in 11.3 Operation Settings.

1) When EnSwitchPDC is set to NON, T4\_AHS\_ON can be set manually. When EnSwitchPDC is set to ON, T4\_AHS\_ON cannot be set manually.

2) When AHS function is set to NON, EnSwitchPDC is

enforced to be NON.

3) When DHW mode is invalid, IBH function is enforced to be HEAT.

4) When AHS function is set to NON, AHS\_PUMPI CONTROL is enforced to be RUN.

## 11.2.8. Holiday away setting

Select the target item and enter the setting page. Adjust the launch settings and values based on end user demands.

### Holiday away setting

T1S_H.A_H	25°C	
T5S_H.A_DHW	25°C	

All set parameters and limitations can be found in 11.3 Operation Settings.

## 11.2.9. Holiday away setting

Up to two phone numbers can be saved, and the maximum length of the phone numbers is 15 characters. If the length is smaller than 15 character, use 0 in the front to indicate blank characters.

### Service call

Phone number	0000000000000	
Mobile number	0000000000000	

## 11.2.10. Restoration of factory settings

Allow all operating parameters to be restored to the factory preset values.

Select YES and confirm to validate this function.

All the settings will come back to factory default. Do you want to restore factory settings?

NO
YES

## 11.2.11. Test run

Refer to 12. Commissioning for further information.

## 11.2.12. Special function

### Special function

Preheating for floor
>

---

Floor drying up
>

### Preheating for floor

Provide mild heat to the concrete or other structural materials around the underfloor water piping in a certain period of time, accelerate the process of dehumidification.

### Preheating for floor

Preheating for floor

---

T1S
25°C

---

t\_ARSTH
72 hours

---

Elapsed time
--

### Preheating for floor

Tw\_out temp.
0°C

The first line is the operating status. Grey means it is off, and green means it is on.

**T1S** is the set temperature.

**t\_ARSTH** is the duration.

**Elapsed time** is the time for which the function is enabled.

**Tw\_out temp.** is the current leaving water temperature.

### Floor drying up

Provide mild heat to the underfloor water piping for initial heating operation to diminish the risk of damage to the floor and piping system.

### Floor drying up

Floor drying up

---

t\_Dryup
8 days

---

t\_Highpeak
5 days

---

t\_Drydown
5 days

### Floor drying up

t\_Drypeak
45°C

---

Start time
00:00

---

Start date
12-02-2023

The first line is the status indicator. Grey means it is off, and green means it is on.

**t\_Dryup** is the time for which the unit rises the temperature.

**t\_Highpeak** is the time for which the unit maintains the temperature.

**t\_Drydown** is the time for which the unit drops the temperature.

**t\_Drypeak** is the target temperature.

This function will be enabled only when the time reaches the Start time and Start day.

When the function is enabled, you can see the interface as below.

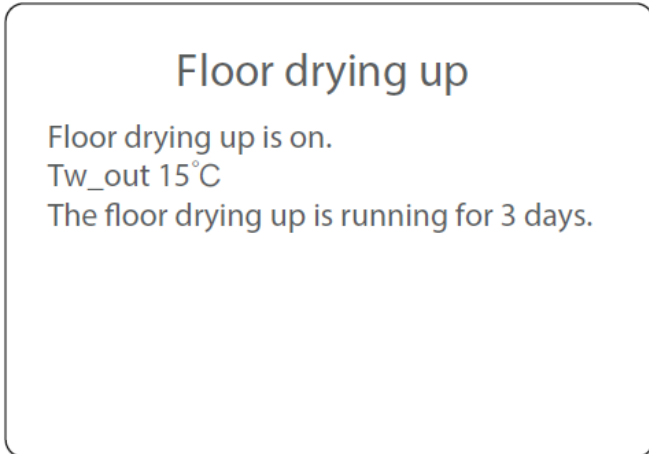

### 11.2.13. Auto restart

Select the target item and enter the setting page. Adjust the launch settings and values based on end user demands.

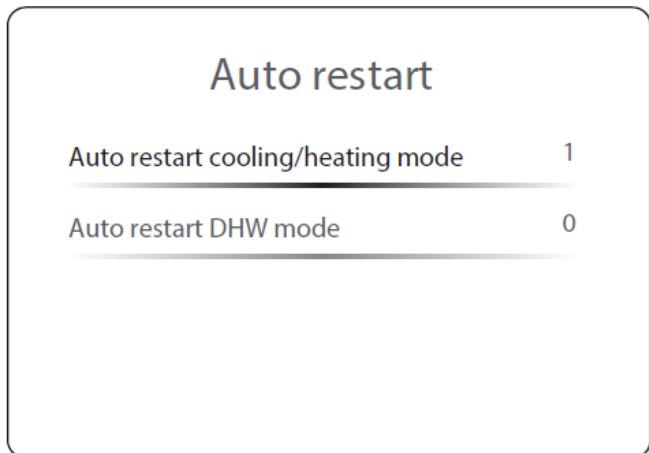

All set parameters and limitations can be found in 11.3 Operation Settings.

### 11.2.14. Power input limitation

Select the target item and enter the setting page. Adjust the launch settings and values based on end user demands.

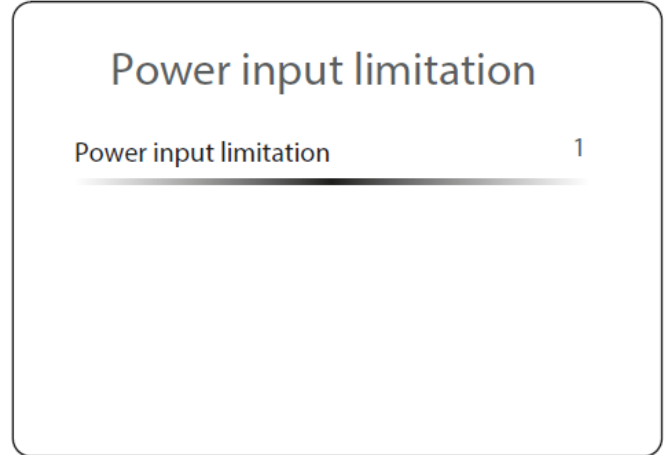

All set parameters and limitations can be found in 11.3 Operation Settings.

### 11.2.15. Input definition

Select the target item and enter the setting page. Adjust the launch settings and values based on end user demands.

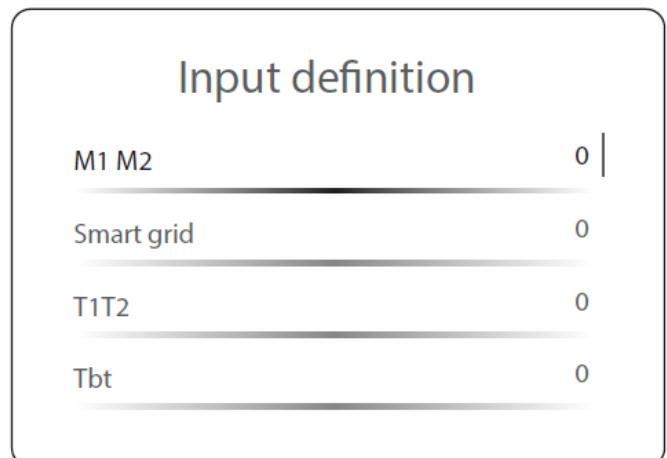

All set parameters and limitations can be found in 11.3 Operation Settings.

## 11.2.16. Cascade setting

Select the target item and enter the setting page. Adjust the launch settings and values based on end user demands.

### Cascade setting

PER_START	10%
TIME_ADJUST	5 minutes

All set parameters and limitations can be found in 11.3 Operation Settings.

## 11.2.17. HMI address setting

Select the target item and enter the setting page. Adjust the launch settings and values based on end user demands.

### HMI address setting

HMI setting	0
HMI address for BMS	1
Stop BIT	1

All set parameters and limitations can be found in 11.3 Operation Settings.

## 11.2.18. Common setting

Select the target item and enter the setting page. Adjust the launch settings and values based on end user demands.

### Common setting

t_DELAY PUMP	20 minutes
t1_ANTILOCK PUMP	24 hours
t2_ANTILOCK PUMP RUN	60 seconds
t1-ANTILOCK SV	24 hours

All set parameters and limitations can be found in 11.3 Operation Settings.

### 11.3.Configuration

Title	Code	State	Default	Min	Max	Interval	Unit
DHW heating setting	DHW mode	Enable or disable DHW mode: 0=NON, 1=YES	1	2	1	1	/
	Disinfect	Enable or disable the disinfect mode: 0=NON, 1=YES	1	2	1	1	/
	DHW priority	Enable or disable DHW priority mode: 0=NON, 1=YES	1	2	1	1	/
	Pump_D	Enable or disable DHW pump mode: 0=NON, 1=YES	0	0	1	1	/
	DHW priority time set	Enable or disable DHW priority time setting: 0=NON, 1=YES	0	0	1	1	/
	dT5_ON	The temperature difference for starting DHW mode	10	1	30	1	°C
	dT1S5	The difference value between Twout and T5 in DHW mode	10	5	40	1	°C
	T4DHWMAX	The maximum ambient temperature at which the heat pump can operate for domestic water heating	43	35	43	1	°C
	T4DHWMIN	The minimum ambient temperature at which the heat pump can operate for domestic water heating	-10	-25	30	1	°C
	t_INTERVAL_DHW	The start time interval of the compressor in DHW mode	5	5	5	/	Minutes
	T5S_DISINFECT	The target temperature of water in the domestic hot water tank in DISINFECT mode	65	60	70	1	°C
	t_DI_HIGHTEMP.	The time for which the highest temperature of water in the domestic hot water tank in DISINFECT mode lasts	15	5	60	5	Minutes
	t_DI_MAX	The maximum time for which disinfection lasts	210	90	300	5	Minutes
	t_DHWHP_RESTRICT	The operating time for heating/cooling	30	10	600	5	Minutes
	t_DHWHP_MAX	The maximum continuous operating time of the heat pump in DHW PRIORITY mode	90	10	600	5	Minutes
	PUMP_D TIMER	Enable or disable the DHW pump to run as scheduled and to keep running for PUMP RUNNING TIME: 0=NON, 1=YES	1	0	1	1	/
	PUMP_D RUNNING TIME	The certain time for which the DHW pump keeps running	5	5	120	1	Minutes
PUMP_D DISINFECT	Enable or disable the DHW pump to operate when the unit is in DISINFECT mode and T5 is larger than or equal to T5S_DI-2: 0=NON, 1=YES	1	0	1	1	/	
ACS function	Enable or disable the double DHW tanks: 0=NON, 1=YES	0	0	1	1	/	
Cooling setting	Cooling mode	Enable or disable the cooling mode: 0=NON,1=YES	1	0	1	1	/
	t_T4_FRESH_C	The refresh time of climate-related curves in cooling mode	0.5	0.5	6	0.5	Hours
	T4CMAX	The highest ambient operating temperature in cooling mode	52	35	52	1	°C
	T4CMIN	The lowest ambient operating temperature in cooling mode	10	-5	25	1	°C
	dT1SC	The temperature difference for starting the heat pump (T1)	5	2	10	1	°C
	dTSC	The temperature difference for starting the heat pump (Ta)	2	1	10	1	°C
	t_INTERVAL_C	Compressor operation delay in cooling mode	5	5	5	/	Minutes
	Zone 1 C-emission	The type of Zone 1 terminal for cooling mode: 0=FCU (fan coil unit), 1=RAD. (radiator), 2=FLH (floor heating)	0	0	2	1	/
	Zone 2 C-emission	The type of Zone 2 terminal for cooling mode: 0=FCU (fan coil unit), 1=RAD. (radiator), 2=FLH (floor heating)	0	0	2	1	/

Title	Code	State	Default	Min	Max	Interval	Unit
Heating setting	Heating mode	Enable or disable the heating mode: 0=NON, 1=YES	1	0	1	1	/
	t_T4_FRESH_H	The refresh time of climate-related curves in heating mode	0.5	0.5	6	0.5	Hour
	T4HMAX	The maximum ambient operating temperature in heating mode	25	20	35	1	°C
	T4HMIN	The minimum ambient operating temperature in heating mode	-15	-25	30	1	°C
	dT1SH	The temperature difference for starting the unit (T1)	5	2	20	1	°C
	dTSH	The temperature difference for starting the unit (Ta)	2	1	10	1	°C
	t_INTERVAL_H	Compressor operation delay in heating mode	5	5	5	/	Minute
	Zone 1 H-emission	The type of Zone 1 terminal for heating mode: 0=FCU (fan coil unit), 1=RAD. (radiator), 2=FLH (floor heating)	1	0	2	1	/
	Zone 2 H-emission	The type of Zone 2 terminal for heating mode: 0=FCU (fan coil unit), 1=RAD. (radiator), 2=FLH (floor heating)	2	0	2	1	/
	Force defrost	Enable or disable the force defrost: 0=NON, 1=YES	0	0	1	1	/
AUTO mode setting	T4AUTOCMIN	The minimum operating ambient temperature for cooling in auto mode	25	20	29	1	°C
	T4AUTOHMAX	The maximum operating ambient temperature for heating in auto mode	17	10	17	1	°C
Temp. type setting	Water flow temp.	Enable or disable the WATER FLOW TEMP.: 0=NON, 1=YES	1	0	1	1	/
	Room temp.	Enable or disable the ROOM TEMP.: 0=NON, 1=YES	0	0	1	1	/
	Double zone	Enable or disable the DOUBLE ZONE: 0=NON, 1=YES	0	0	1	1	/
Room thermostat setting	Room thermostat	The style of room thermostat: 0=NON, 1=MODE SET, 2=ONE ZONE, 3=DOUBLE ZONE	0	0	3	1	/
	Mode set priority	Select the priority mode in ROOM THERMOSTAT: 0=HEAT, 1=COOL	0	0	1	1	/
Other heat source	IBH FUNCTION	Select the mode of IBH (BACKUP HEATER): 0=HEAT+DHW, 1=HEAT	0	0	1	1	/
	IBH locate	IBH/AHS installation location: 0=pipe loop	0	0	0	/	/
	dT1_IBH_ON	The temperature difference between T1S and T1 for starting the backup heater	5	2	10	1	°C
	t_IBH_DELAY	The time for which the compressor has run before startup of the first step backup heater	30	15	120	5	Minute
	T4_IBH_ON	The ambient temperature for starting the backup heater	-5	-15	30	1	°C
	P_IBH1	Power input of IBH1	0	0	20	0.5	kW
	P_IBH2	Power input of IBH2	0	0	20	0.5	kW
	AHS FUNCTION	Enable or disable the AHS (AUXILIARY HEATING SOURCE) function: 0=NON, 1=HEAT, 2=HEAT+DHW	0	0	2	1	/
	AHS_PUMPI CONTROL	Select the pump operating status when only AHS runs: 0=RUN, 1=NOT RUN	0	0	1	1	/
	dT1_AHS_ON	The temperature difference between T1S and T1 for starting the auxiliary heating source	5	2	20	1	°C
	t_AHS_DELAY	The time for which the compressor has run before startup of the additional heating source	30	5	120	5	Minute
	T4_AHS_ON	The ambient temperature for starting the additional heating source	-5	-15	30	1	°C
	EnSwitchPDC	Enable or disable automatic switch of heat pump and auxiliary heating source based on running cost: 0=NON, 1=YES	0	0	1	1	/
	GAS-COST	Price of gas	0.85	0	5	0.01	Price/m <sup>3</sup>
	ELE-COST	Price of electricity	0.20	0	5	0.01	Price/kWh
MAX-SETHEATER	Maximum set temperature of additional heating source	80	0	80	1	°C	



Other heat source	MIN-SETHEATER	Minimum set temperature of additional heating source	30	0	80	1	°C
	MAX-SIGHEATER	The voltage corresponding to the maximum set temperature of additional heating source	10	0	10	1	V
	MIN-SIGHEATER	The voltage corresponding to the minimum set temperature of additional heating source	3	0	10	1	V
	TBH FUNCTION	Enable or disable the TBH (TANK BOOSTER HEATER) function: 0=NON, 1=YES	1	0	1	1	/
	dT5_TBH_OFF	The temperature difference between T5 and T5S (the set water tank temperature) for turning the booster heater off	5	0	10	1	°C
	t_TBH_DELAY	The time for which the compressor has run before startup of the booster heater	30	0	240	5	Minute
	T4_TBH_ON	The ambient temperature for starting the tank booster heater	5	-5	50	1	°C
	P_TBH	Power input of TBH	2	0	20	0.5	kW
	Solar function	Enable or disable the SOLAR function: 0=NON, 1=ONLY SOLAR, 2=SOLAR+HP (HEAT PUMP)	0	0	2	1	/
	Solar control	Solar pump (pump_s) control: 0=T <sub>solar</sub> , 1=SL1SL2	0	0	1	1	/
	Deltatsol	The temperature deviation for enabling SOLAR	10	5	20	1	°C
Holiday away setting	T1S_H.A_H	The target outlet water temperature for space heating in HOLIDAY AWAY mode	25	20	25	1	°C
	T5S_H.A_DHW	The target temperature for heating domestic hot water in HOLIDAY AWAY mode	25	20	25	1	°C
Special function	Preheating for floor T1S	The set outlet water temperature during first floor preheating	25	25	35	1	°C
	t_ARSTH	Running time for first floor preheating	72	48	96	12	Hour
	t_Dryup	Temp-up days for floor drying	8	4	15	1	Day
	t_Highpeak	Days for floor drying	5	3	7	1	Day
	t_Drydown	Temp-down days for floor drying	5	4	15	1	Day
	t_Drypeak	Outlet water temperature for floor drying	45	30	55	1	°C
	Start time	The start time of floor drying	00:00	0:00	23:30	1/30	h/min
	Start date	The start date of floor drying	Current date+1	Current date+1	31/12 /2099	1/1/1	Dd/m m/yyyy y
	Preheating for floor	Enable or disable floor preheating: 0=NON, 1=YES	0	0	1	1	/
Floor drying up	Enable or disable floor drying: 0=NON, 1=YES	0	0	1	1	/	
Auto restart	Auto restart cooling/heating mode	Enable or disable the auto restart of cooling/heating mode: 0=NON, 1=YES	1	0	1	1	/
	Auto restart DHW mode	Enable or disable the auto restart of DHW mode: 0=NON, 1=YES	1	0	1	1	/
Power input limitation	Power input limitation	The type of power input limitation	1	1	8	1	/
Input definition	M1 M2	Define the function of the M1M2 switch: 0=REMOTE ON/OFF, 1=TBH ON/OFF, 2=AHS ON/OFF	0	0	2	1	/
	Smart grid	Enable or disable the SMART GRID: 0=NON, 1=YES	0	0	1	1	/
	T1T2	Control options of Port T1T2: 0=NON, 1=RT/Ta_PCB	0	0	1	1	/
	Tbt	Enable or disable the TBT: 0=NON, 1=YES	0	0	1	1	/
	P_X PORT	Select the function of P_X PORT: 0=DEFORST, 1=ALARM	0	0	1	1	/
Cascade setting	PER_START	Percentage of operating units among all units	10	10	100	10	%
	TIME_ADJUST	Time interval for determining the necessity of unit loading/unloading	5	1	60	1	Minute
HMI address setting	HMI setting	Choose the HMI: 0=MASTER	0	0	0	/	/
	HMI address for BMS	Set the HMI address code for BMS	1	1	255	1	/
	Stop BIT	Upper computer stop bit: 1=STOP BIT1, 2=STOP BIT2	1	1	2	1	/

Common setting	t_DELAY PUMP	The time for which the compressor has run before startup of the pump	2	0.2	20	0.5	Minute
	t1_ANTILOCK PUMP	The pump anti-lock interval	24	5	48	1	Hour
	t2_ANTILOCK PUMP RUN	The pump anti-lock running time	60	0	300	30	Second
	t1-ANTILOCK SV	The valve anti-lock interval	24	5	48	1	Hour
	t2-ANTILOCK SV RUN	The valve anti-lock running time	60	0	300	30	Second
	Ta-adj.	The corrected value of Ta inside the wired controller	-2	-10	10	1	°C
	F-PIPE LENGTH	Select the total length of the liquid pipe (F-PIPE LENGTH): 0=F-PIPE LENGTH<10m, 1=F-PIPE LENGTH>=10m	0	0	1	1	/
	PUMP_I SILENT OUTPUT	The Pump_I max output limitation	100	50	100	5	%
	Energy metering	Enable or disable the energy analysis: 0=NON, 1=YES	1	0	1	1	/
	Pump_O	Additional circulation pump P_o operation: 0=ON (keep running) 1=Auto (controlled by the unit)	0	0	1	1	/

## 12.COMMISSIONING

Test run is used to confirm the operation of the valves, air purge, circulation pump operation, cooling, heating and domestic water heating.

### Test run

- Point check > |

---

- Air purge >

---

- Circulated pump running >

---

- Cooling running >

### Test run

- Heating running > |

---

- Cooling running >

---

- DHW running >

### Checklist during commissioning

CHECK	Description
	Test run for the actuator.
	Air purge
	Test run for operation.
	Check of the minimum flow rate in all conditions.

### 12.1.Test Run for the Actuator

**NOTE**

*During the commissioning of the actuator, the protection function of the unit is disabled. Excessive use may damage components.*

**Why**  
Check whether each actuator is in good working conditions.

## What - Actuator List

N°	Name	Note	
1	SV2	Three-way valve 2	
2	SV3	Three-way valve 3	
3	Pump_I	Integrated pump	
4	Pump_O	Outside pump	
5	Pump_C	Zone 2 pump	
6	IBH	Internal backup heater	
7	AHS	Additional heat source	
8	SV1	Three-way valve 1	Invisible if DHW is disabled
9	Pump_D	Circulation pump for DHW	Invisible if DHW is disabled
10	Pump_S	Solar pump	Invisible if DHW is disabled
11	TBH	Tank backup heater	Invisible if DHW is disabled

## How

1	Go to "FOR SERVICEMAN" (Refer to 10.2 Configuration).
2	Find "Test run" and enter the process.
3	Find "Point check" and enter the process.
4	Select the actuator, and press <input type="radio"/> to activate or deactivate the actuator. The status ON means the actuator is activated, and OFF means the actuator is deactivated.

### NOTE

*When you return to the upper layer, all actuators turn OFF automatically.*

## 12.2. Air Purge

### Why

To purge out the remaining air in the water loop.

### How

1	Go to "FOR SERVICEMAN" (Refer to 10.2 Configuration).
2	Find "Test run" and enter the process.
3	Find "Air purge" and enter the process.
4	Select "air purge", and press <input type="radio"/> to activate or deactivate the air purge function. <input checked="" type="radio"/> means the air purge function is activated, and <input type="radio"/> means the air purge function is deactivated.

### Besides

"Air purge pump_i output"	To set pump_i output. The higher the value is, the pump gives a higher output.
"Air purge running time"	To set the duration of air purge. When the set time is due, air purge is deactivated.
"Status check"	Additional operation parameters can be found.

## 12.3. Test Run

### Why

Check whether the unit is in good working conditions.

### What

Circulated pump operation  
Cooling operation  
Heating operation  
DHW operation

### How

1	Go to "FOR SERVICEMAN" (Refer to 10.2 Configuration)
2	Find "Test run" and enter the page.
3	Find "Other" and enter the process.
4	Select "XXXX"* and press <input type="radio"/> to run the test. During test, press <input type="radio"/> , select OK and confirm to return to the upper layer. * - Four performance test options are shown in <b>What</b> .

## NOTE

*In performance test, the target temperature is preset and cannot be changed.*

*If the outdoor temperature is outside the range of operating temperature, the unit may not operate or may not deliver the required capacity.*

## 12.4. Check of the Minimum Flow Rate

1	Check the hydraulic configuration to find out the space heating loops that can be closed by mechanical, electronic, or other valves.
2	Close all space heating loops that can be closed.
3	Start and operate the circulation pump (See "11.3 Test Run").
4	Read out the flow rate(a) and modify the bypass valve settings until the set value reaches the minimum flow rate required + 2 l/min.

(a) *During pump test run, the unit can operate below the minimum required flow rate.*

## 13. HAND-OVER TO THE USER

Once the test run is finished and the unit operates properly, please make sure the following is clear for the user:

- Fill the installer setting table (in the OPERATION MANUAL) with the actual settings.
- Make sure that the user has the printed documentation and ask him/her to keep it for future reference.
- Explain to the user how to properly operate the system and what to do in case of problems.
- Basic operation guidelines can be found in the OPERATION MANUAL.
- For additional information about operation, see 13.2 Additional Operation Reference.
- Show the user what to do for the maintenance of the unit.
- Explain to the user about energy saving tips as described below.

### 13.1. Energy Saving Tips

#### Tips about room temperature

• Make sure the desired room temperature is NEVER too high (in heating mode) or too low (in cooling mode), and ALWAYS set it according to your actual needs. An rise/drop of one degree centigrade can save up to 6% of heating/cooling costs.

• Do NOT increase/decrease the desired room temperature to speed up space heating/cooling as such operation cannot accelerate the heating/cooling process.

• When your system layout contains slow heat emitters (such as underfloor heating), avoid large fluctuations of the desired room temperature and do NOT drop or rise the room temperature excessively. Otherwise, it will take more time and energy to heat up/cool down the room again.

• Use a weekly schedule to meet your normal space heating or cooling needs. If necessary, you can easily deviate from the schedule:

1) For shorter periods: You can override the scheduled room temperature until the next scheduled action starts. For example, you can do this when you have a party, or when you are leaving for a couple of hours.

2) For longer periods: You can use the holiday mode.

#### Tips about DHW tank temperature

• Use a weekly schedule to meet your normal domestic hot water needs (only in scheduled mode).

• Program to heat up the DHW tank to a preset value during the night, because the space heating demand during such period is low.

• If heating up the DHW tank only at night is not sufficient, program to additionally heat up the DHW tank to a preset value during the day.

• Make sure the desired DHW tank temperature is NOT too high. For example, after installation, lower the DHW tank temperature daily by 1°C and check if you still have enough hot water.

• Program to turn ON the domestic hot water pump only during periods of the day when instant hot water is necessary, such as in the morning and evening.

## 13.2. Additional Operation Reference

### 13.2.1. Mode

**What**

Set the unit operation mode for room comfort.  
 Three modes in all – Space heating mode, space cooling mode, and auto mode.

AUTO mode	The unit will select the operation mode automatically based on the outdoor ambient temperature and some settings in "FOR SERVICEMEN". This icon is invisible if either the heating function or cooling function is disabled.
Heating	The icon of heating is invisible if the heating function is disabled.
Cooling	The icon of cooling is invisible if the cooling function is disabled.

### 13.2.2. Schedule

**What**

Make unit operation plans.  
 This function is based on the current time displayed on the HMI. Make sure the time is correct.

**Conflicts and operation priority**

- 1) A daily schedule and a weekly schedule can work simultaneously.
- 2) For all schedules, timers (if more than one) for the same zone or appliance must be different, and the operation mode of Zone 1 and Zone 2 in the same time setting must be the same. Otherwise, the most recent setting is invalid, and a notice window appears.
- 3) When the unit is in Holiday away or Holiday home mode, the daily timer, weekly timer and temperature curve function (12.2.3 Weather temp. setting) become invalid and will not recover until the unit quits Holiday away and Holiday home mode.
- 4) If Holiday away and Holiday home mode are active simultaneously, the date for both the modes cannot be overlapped. Otherwise, the most recent setting is invalid, and a notice window appears.

**More**

- 1) All daily schedules and weekly schedules become inactive, the set time turns to 0:00, and the set temperature turns to 24°C in case of any change of the temperature control mode (9.3.5).
- 2) The unit runs disinfection based on the settings of 11.2.4 DHW setting, if the disinfection function in Holiday away mode is inactive.
- 3) In case of power failure during Holiday away or Holiday home mode, the unit will run in Holiday away or Holiday home mode after power restoration if the current date is still within the period for Holiday away or Holiday home mode.
- 4) If the mode setting is OFF, the set temperature turns to 0°C.

### 13.2.3. Weather temp. setting

**What**

- Allow the set water temperature to regulate depending on the outdoor ambient temperature.
- This function is only applicable to space heating and space cooling. When the function is active, the unit will apply the temperature curve if the current operation mode is set the same as that of the activated function.
  - Three types of curves in all – Standard, ECO, Custom. Illustration of temperature curve

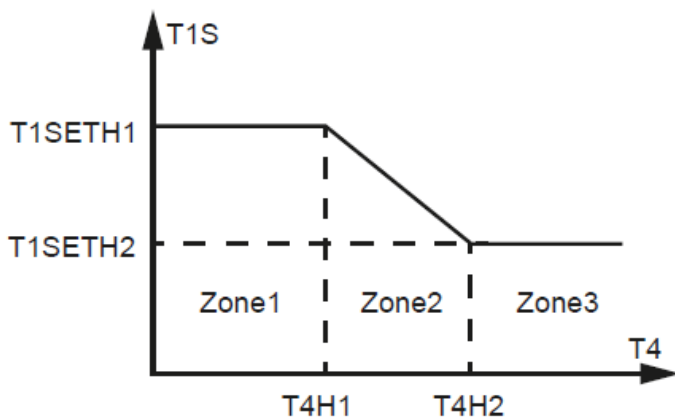

T1S – set water temperature  
 T4 – outdoor ambient temperature  
 In Zone 1 and Zone 3, the set water temperature remains stable despite the change of the outdoor ambient temperature. In Zone 2, the set water temperature regulates depending on the outdoor ambient temperature.

**Standard**

Up to 8 curves are preset by the manufacturer, and the parameter values are as below.

For heating (FLH – underfloor heating application):

T4	≤-20	≤-19	≤-18	≤-17	≤-16	≤-15	≤-14	≤-13	≤-12	≤-11	≤-10
1-T1S	38	38	38	38	38	37	37	37	37	37	37
2-T1S	37	37	37	37	37	36	36	36	36	36	36
3-T1S	38	38	38	35	35	35	35	35	35	34	34
4-T1S	35	35	35	34	34	34	34	34	34	33	33
5-T1S	34	34	34	33	33	33	33	33	33	32	32
6-T1S	32	32	32	32	31	31	31	31	31	31	31
7-T1S	31	31	31	31	30	30	30	30	30	30	30
8-T1S	29	29	29	29	28	28	28	28	28	28	28
T4	≤-9	≤-8	≤-7	≤-6	≤-5	≤-4	≤-3	≤-2	≤-1	0	1
1-T1S	36	36	36	36	36	36	35	35	35	35	35
2-T1S	35	35	35	35	35	35	34	34	34	34	34
3-T1S	34	34	34	34	33	33	33	33	33	33	32
4-T1S	33	33	33	33	32	32	32	32	32	32	31
5-T1S	32	32	32	32	31	31	31	31	31	31	30
6-T1S	31	30	30	30	30	30	30	30	30	29	29
7-T1S	30	29	29	29	29	29	29	29	29	28	28
8-T1S	28	27	27	27	27	27	27	27	27	26	26
T4	2	3	4	5	6	7	8	9	10	11	12
1-T1S	35	34	34	34	34	34	34	33	33	33	33
2-T1S	34	33	33	33	33	33	33	32	32	32	32
3-T1S	32	32	32	32	32	31	31	31	31	31	31
4-T1S	31	31	31	31	31	30	30	30	30	30	30
5-T1S	30	30	30	30	30	29	29	29	29	29	29
6-T1S	29	29	29	29	29	28	28	28	28	28	28
7-T1S	28	28	28	28	28	27	27	27	27	27	27
8-T1S	26	26	26	26	26	26	26	25	25	25	25
T4	13	14	15	16	17	18	19	≥20			
1-T1S	33	33	32	32	32	32	32	32	32	32	32
2-T1S	32	32	31	31	31	31	31	31	31	31	31
3-T1S	30	30	30	30	30	30	30	29	29	29	29
4-T1S	29	29	29	29	29	29	29	26	26	26	26
5-T1S	28	28	28	28	28	28	28	27	27	27	27
6-T1S	27	27	27	27	27	27	27	26	26	26	26
7-T1S	26	26	26	26	26	26	26	25	25	25	25
8-T1S	25	25	25	24	24	24	24	24	24	24	24

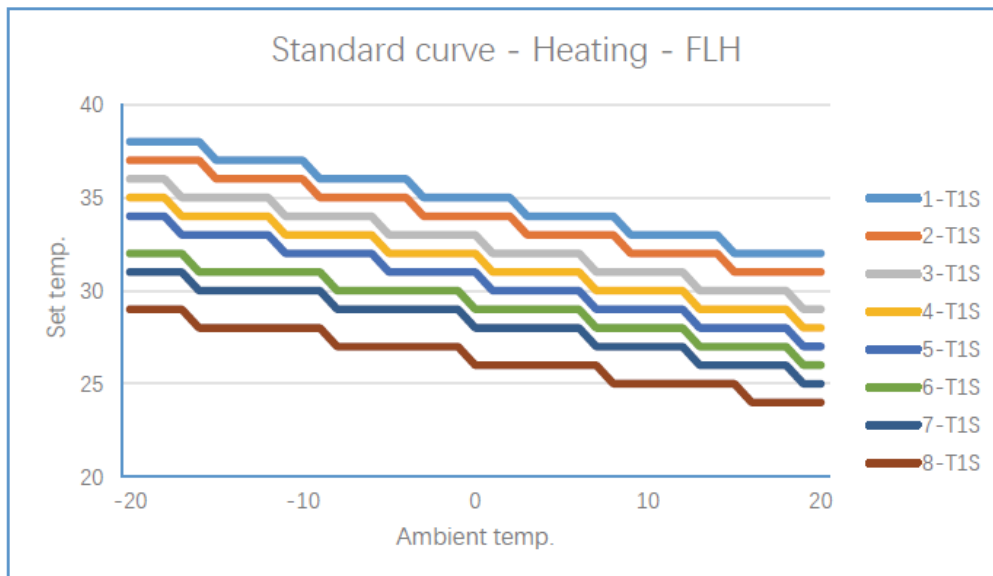

For heating (RAD – radiator application, FCU – fan coil application):

T4	≤-20	≤-19	≤-18	≤-17	≤-16	≤-15	≤-14	≤-13	≤-12	≤-11	≤-10
1-T1S											
2-T1S											
3-T1S											
4-T1S											
5-T1S											
6-T1S											
7-T1S											
8-T1S											
T4	≤-9	≤-8	≤-7	≤-6	≤-5	≤-4	≤-3	≤-2	≤-1	0	
1-T1S											
2-T1S											
3-T1S											
4-T1S											
5-T1S											
6-T1S											
7-T1S											
8-T1S											

For cooling (FLH – underfloor heating application):

T4	-10≤T4<15	15≤T4<22	22≤T4<30	30≤T4
1-T1S	20	18	18	18
2-T1S	21	19	18	18
3-T1S	22	20	19	18
4-T1S	23	21	19	18
5-T1S	24	21	20	18
6-T1S	24	22	20	19
7-T1S	25	22	21	19
8-T1S	25	23	21	20

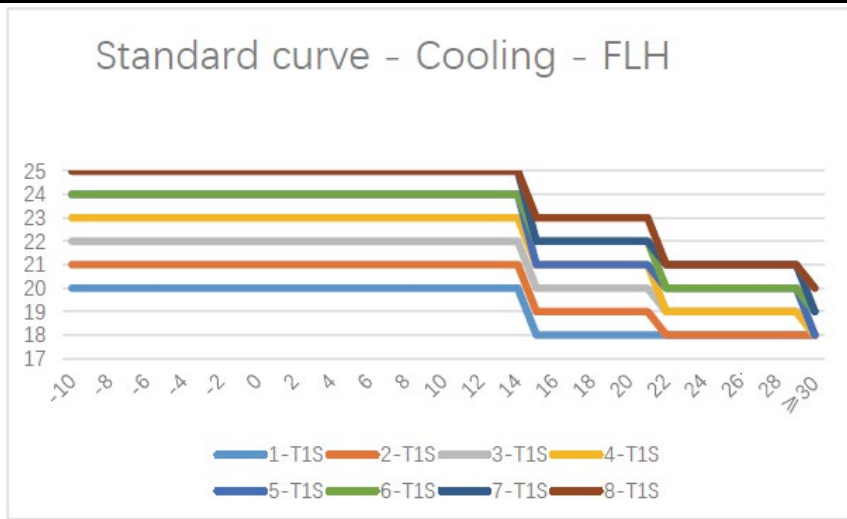

For cooling (FCU – fan coil application):

T4	$-10 \leq T4 < 15$	$15 \leq T4 < 22$	$22 \leq T4 < 30$	$30 \leq T4$
1-T1S	16	11	8	5
2-T1S	17	12	9	6
3-T1S	18	13	10	7
4-T1S	19	14	11	8
5-T1S	20	15	12	9
6-T1S	21	16	13	10
7-T1S	22	17	14	11
8-T1S	23	18	15	12

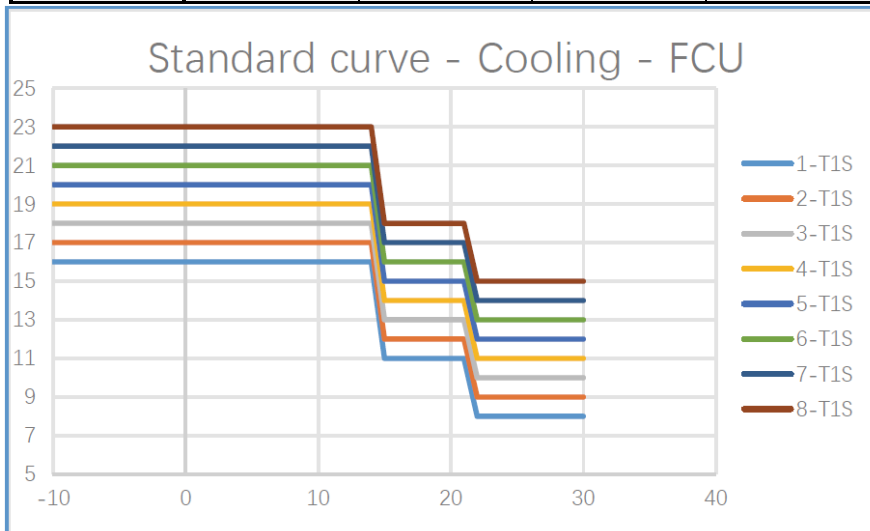

### About Temperature offset

It makes the overall set water temperature of the temperature curve increase or decrease. The temperature curve rises or drops in the illustration.

### ECO

#### NOTE

ECO is available for Zone 1 heating mode only.

ECO curve is to force the unit to apply low-temperature heating.

You can see “ECO timer” at the bottom of the page. You can set the start time and end time of the timer and activate the timer. If the timer is active, the unit will execute the ECO curve only during the set period of the timer. If the timer is inactive, the unit will execute the ECO curve all the way.

### Custom

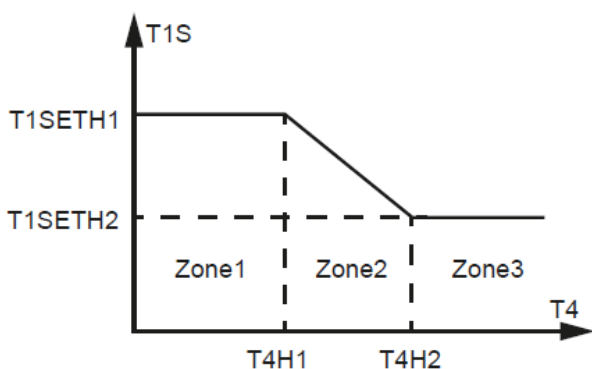

T1S – Set water temperature

T4 – Outdoor ambient temperature

T1SETH1, T1SETH2, T4H1, and T4H2 can be adjusted.

#### NOTE

The illustration on HMI is for reference only. If the set T1SETH1 is lower than T1SETH2 or T4H1 is lower than T4H2, the unit will reverse T1SETH1 and T1SETH2, T4H1 and T4H2 automatically.

### 13.2.4. DHW setting

#### NOTE

Invisible if DHW MODE is disabled.

#### What

More settings of DHW.

#### Disinfection

- When the unit is running in disinfection mode with DHW on, if you turn off DHW on the home page, the unit will ask if you want to disable the disinfection. If you confirm the disablement, a notice window will appear.

- When the unit is running in disinfection mode with DHW off, if you turn on DHW on the home page, the disinfection continues.



## Tank heater

- The tank heater and backup heater cannot operate simultaneously. The most recent setting is valid while the previous setting becomes invalid

- For instance, when the backup heater is valid and running, if the tank heater is turned off, the backup heater stops running.

## 13.2.5. Options

### What

More general settings.

### Silent mode

The start time and end time of the silent mode timer cannot be identical.

If two silent mode timers are activated simultaneously, the date of both the timers cannot be overlapped.

Otherwise, the most recent setting is invalid, and a notice window appears.

### Backup heater

Invisible if IBH and AHS are disabled.

### WLAN setting

In case of any change of the WIFI name, the unit will lose WLAN connection and need to be reconnected.

### Force defrost

Invisible if the unit is running in cooling mode.

## 13.2.6. Unit status

### What

More information of the unit and its operation status.

### Operating parameter

The run time is rounded down. For instance, if the unit is hour, and the actual run time is 0.5 h, the displayed value is 0.

### Energy metering

For accumulated data(Day, Week, Month, Year):

1) The start time is the beginning of that day, week, month, year.

2) If the time of HMI is reset and there is data logging from the beginning of that day, week, month, year, the calculation will start from the beginning of that day, week, month, year.

3) If the time of HMI is reset and there is no data logging from the beginning of that day, week, month, or year, the calculation will start from the time when the resetting occurs.

### For Historical data

It records up to 10-year data. For instance, if the unit starts running from 2023, when it comes to 2035, you can check the data only from 2025 to 2035.

## 13.2.7. Error info

### What

Error history of the unit.

The first column shows the unit number, if slave units are available.

Press the Menu button for 5 seconds to clear all error records.

## 13.2.8. FAQ

### What

Assistance for common questions.

## 14. TROUBLESHOOTING

This section provides useful information about diagnosing and correcting certain problems that may occur to the unit.

### 14.1. General Guidelines

Before starting the troubleshooting procedure, visually inspect the unit and look for obvious defects such as loose connections or defective wiring.

When a safety device is activated, stop the unit and find out the cause of such activation before resetting the safety device. Under no circumstances can safety devices be bridged or unit parameters be changed. If the cause of the problem cannot be found, call the local dealer.

If the pressure relief valve does not work properly or should be replaced, always reconnect the flexible hose attached to the pressure relief valve to prevent water from dripping out of the unit.

#### NOTE

*For problems related to the optional solar kit for domestic water heating, refer to the troubleshooting in the documents for the kit.*

### 14.2. Typical Abnormalities

**Symptom 1:** The unit is turned on but the unit fails to operate in cooling or heating mode as expected.

POSSIBLE CAUSE	TROUBLESHOOTING
Incorrect temperature setting	Check the parameters (T4HMAX and T4HMIN in heating mode; T4CMAX and T4CMIN in cooling mode; T4DHWMAX and T4DHWMIN in DHW mode). For the parameter range, please refer to 10.3 Operation Settings.
Too small water flow	<ul style="list-style-type: none"> <li>- Verify that all shut off valves of the water circuit are in the right position.</li> <li>- Check if the water filter is plugged.</li> <li>- Make sure there is no air in the water system.</li> <li>- Check the water pressure. The water pressure must be larger than or equal to 1.5 bar.</li> <li>- Make sure that the expansion vessel is not broken.</li> </ul>
Too small water volume in the installation	Make sure that the water volume in the installation is above the minimum required value. Please refer to 7.1 Preparations for Installation.

**Symptom 2:** The unit is turned on but the compressor fails to start.

POSSIBLE CAUSE	TROUBLESHOOTING
The unit may operate out of its operating range (too low water temperature).	<p>In case of low water temperature, the system starts the backup heater to reach the minimum water temperature first (12°C).</p> <ul style="list-style-type: none"> <li>- Verify that the power supply for the backup heater is correct.</li> <li>- Verify that the thermal fuse of the backup heater is closed.</li> <li>- Verify that the thermal protector of the backup heater is not activated.</li> <li>- Verify that the contactors of the backup heater are not broken.</li> </ul>

**Symptom 3:** Noise is generated from the pump (cavitation).

POSSIBLE CAUSE	TROUBLESHOOTING
Air in the system.	Purge the air.
Too small water pressure at the pump inlet	<ul style="list-style-type: none"> <li>- Check the water pressure.</li> <li>- The water pressure must be larger than or equal to 1.5 bar.</li> <li>- Verify that the expansion vessel is not broken.</li> <li>- Verify that the pre- pressure of the expansion vessel is set correctly. See 6.1 Preparations for Installation.</li> </ul>

**Symptom 4:** The water pressure relief valve opens.

POSSIBLE CAUSE	TROUBLESHOOTING
Broken expansion vessel	Replace the expansion vessel.
Water pressure in the installation higher than 0.3 MPa.	Make sure that the water pressure in the installation is within 0.10 to 0.20 MPa.

**Symptom 5:** The water pressure relief valve leaks.

POSSIBLE CAUSE	TROUBLESHOOTING
Blockage of water pressure relief valve outlet	<ul style="list-style-type: none"> <li>- Check for correct operation of the pressure relief valve by turning the black knob on the valve counterclockwise:</li> <li>- If you do not hear a clacking sound, contact your local dealer.</li> <li>- In case water keeps running out of the unit, close the shut-off Valves at both the water inlet and outlet, and then contact your local dealer.</li> </ul>

**Symptom 6:** Insufficient space heating capacity at low outdoor temperature.

POSSIBLE CAUSE	TROUBLESHOOTING
Backup heater not activated	<ul style="list-style-type: none"> <li>- Check whether the IBH function is enabled.</li> <li>- Check whether the thermal protector of the backup heater has been activated.</li> <li>- Check whether the booster heater is running. The backup heater and booster heater cannot operate simultaneously.</li> </ul>
Excessive heat pump capacity used for heating domestic hot water (applicable only to installations with a domestic hot water tank).	Verify that the "t_DHWHP_MAX" and "t_DHWHP_RESTRICT" are configured appropriately: <ul style="list-style-type: none"> <li>- Make sure that the "DHW PRIORITY" in the user interface is disabled.</li> <li>- Enable the "T4_TBH_ON" in the user interface/FOR SERVICEMEN to activate the booster heater for domestic water heating.</li> </ul>

**Symptom 7:** The unit cannot switch from Heating mode to DHW mode immediately.

POSSIBLE CAUSE	TROUBLESHOOTING
Too small volume of tank and low location of water temperature probe	<ul style="list-style-type: none"> <li>- Set "dT1S5" to the maximum value, and set "t_DHWHP_RESTRICT" to the minimum value.</li> <li>- Set dT1SH to 2°C.</li> <li>- Enable the TBH. The TBH should be controlled by the ODU.</li> <li>- If AHS is available, turn on it. the heat pump will turn on once the requirements for turning it on are met.</li> <li>- If both the TBH and AHS are not available, try to change the position of the T5 probe (Refer to 3.2 Domestic Hot Water Tank).</li> </ul>

**Symptom 8:** The heat pump stops operating in DHW mode although the set temperature is not reached, and space heating is required but the unit stays in DHW mode.

POSSIBLE CAUSE	TROUBLESHOOTING
Small surface of coil in the tank	Same as Symptom 7
TBH or AHS not available	The heat pump will stay in DHW mode until "t_DHWHP_MAX" or the set temperature is reached. Add a TBH or AHS for DHW operation. The TBH and AHS should be controlled by the unit..

**Symptom 9:** The unit cannot switch from DHW mode to Heating mode immediately

POSSIBLE CAUSE	TROUBLESHOOTING
Small heat exchanger for space heating	Set "t_DHWHP_MAX" to the minimum value. The suggested value is 60 min. If the circulation pump out of the unit is not controlled by the unit, try to connect it to the unit. Add a 3-way valve at the inlet of the fan coil to provide enough water flow.
Small space heating load	Normal , no need for heating
Disinfection function enabled without TBH	- Disable the disinfection function - Add a TBH or AHS for DHW operation
The FAST WATER function is manually turned on after the hot water meets the requirements, and the heat pump fails to switch to the air-conditioning mode in time when air conditioning is required.	Manually turn off the FAST WATER function
In case of a low ambient temperature, the hot water is not enough and the AHS fails to operate or fails to operate in time.	-Set "T4DHWMIN". The suggested value is larger than or equal to -5°C -Set "T4_TBH_ON". The suggested value is larger than or equal to 5°C
DHW mode priority	If there is an AHS or IBH connected to the unit, when the ODU fails, the hydraulic module board must run DHW mode till the water temperature reaches the set value before change to heating mode.

## 14.3.Error Codes

The explanation about each error code can be found on the wired controller.

Reset the unit by powering off and powering on it.

If resetting the unit is invalid, contact the local dealer.

### CAUTION

*In winter, if the unit suffers from E0 and Hb malfunction and the unit is not repaired in time, the water pump and pipeline system may be damaged due to freezing.*

*Take proper measures to eliminate the E0 and Hb malfunction.*

## 15.MAINTENANCE

Regular checks and inspections at certain intervals are required to guarantee the optimal performance of the unit.

### 15.1.Safety Precautions for Maintenance

#### **DANGER**

*Risk of electrocution.*

#### **WARNING**

- Please note that some parts of the electric component box are hot.
- Do not rinse the unit. Otherwise, electric shock or fire may occur.
- Do not leave the unit unattended when the service panel is removed.

#### **NOTE**

*Before performing any maintenance or service work, touch a metal part of the unit to eliminate static electricity and to protect the PCB.*

### 15.2.Annual Maintenance

#### 15.2.1. Water pressure

Check the water pressure. If it is below 1 bar, fill the system with more water.

#### 15.2.2. Water strainer

Clean the water strainer.

#### 15.2.3. Water pressure relief valve

•Check for correct operation of the pressure relief valve by turning the black knob on the valve counterclockwise:

•If no clacking sound is heard, contact the local dealer.

•In case the water keeps running out of the unit, close the shut-off valves at both the water inlet and outlet, and then contact the local dealer.

#### 15.2.4. Pressure relief valve hose

Verify that the pressure relief valve hose is positioned appropriately to drain the water.

#### 15.2.5. Insulation cover of backup heater

Verify that the insulation cover of the backup heater is fastened tightly around the backup heater vessel.

#### 15.2.6.Pressure relief valve of domestic hot water tank (supplied by the user)

Applicable only to installations with a domestic hot water tank. Check for correct operation of the pressure relief valve on the domestic hot water tank.

#### 15.2.7.Booster heater of domestic hot water tank

Applicable only to installations with a domestic hot water tank. Remove the scale buildup from the booster heater, especially in regions with hard water. Drain the domestic hot water tank, remove the booster heater from the domestic hot water tank, and dissolve the scale with specific descaling agent.

#### 15.2.8.Switch box of the unit

•Visually inspect the switch box and look for obvious defects such as loose connections or defective wiring.

•Verify that cabling will not be subject to wear, corrosion, excessive pressure, vibration, sharp edges or any other adverse environmental effects. Take into account the effects of aging or continual vibration from sources such as compressors or fans.

•Check for correct operation of contactors with an ohmmeter. All contacts of these contactors must be in open position.

#### 15.2.9.Temperature sensor

Check the resistance of each temperature sensor with an ohmmeter.

#### **NOTE**

*As the connector is small, use thin probes.*

•Refer to 2.7.4 Control board for the socket of each temperature sensor, and unplug the connector.

•Check the resistance with an ohmmeter.

•Compare the read value with that in the resistance characteristics table. The temperature sensor is in good conditions if the deviation is within tolerance.

For the temperature sensor in accessories and temperature sensors on the water loop, e.g. TW\_in and TW\_out, refer to Table 3-1.

#### 15.2.10.Temperature sensor

The “safety precautions” must be observed. Make sure that the glycol solution disposed in accordance with local regulations and standards.

#### 15.2.11.Refrigerant leakage check

Refer to 15.2. Leak Detection Methods.

## 15.2.12. Flow switch failure

Water may enter the flow switch and may freeze when the temperature is too low. In such a case, the flow switch should be removed and dried before being installed in the unit. Before removal of the flow switch, the water in the system should be drained.

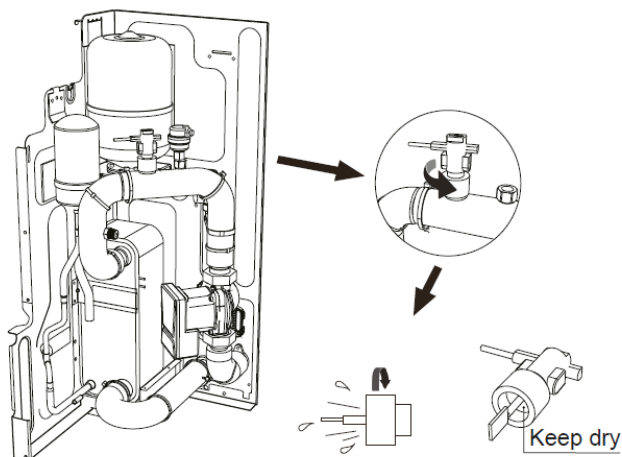

Rotate the flow switch counterclockwise to remove it. Dry the flow switch completely.

## 16. SERVICE INFORMATION

### 16.1. Label for Refrigerant Presence

Equipment should be provided with a label stating that it has been de-commissioned and emptied of refrigerant. The label should be dated and signed. Ensure that proper labels are pasted on the equipment stating the equipment contains flammable refrigerant.

### 16.2. Leak Detection Methods

The following leak detection methods are deemed acceptable for systems containing flammable refrigerants.

An electronic leak detector should be used to detect flammable refrigerants, but its sensitivity may not be adequate, or the detector may need re-calibration. (Detection equipment should be calibrated in a refrigerant-free area.) Ensure that the detector is not a potential source of ignition and is suitable for the refrigerant. Leak detection equipment should be set at a percentage of the LFL of the refrigerant and should be calibrated to be suitable for the refrigerant employed. The appropriate percentage of gas (25% maximum) is confirmed. Leak detection fluids are suitable for use with most refrigerants but detergents containing chlorine should not be used as the chlorine may react with the refrigerant and corrode the copper pipes. If a leak is suspected, all naked flames should be removed or extinguished. If a leakage of refrigerant is found and

brazing is required, all of the refrigerant should be recovered from the system, or isolated (by means of shut off valves) in a part of the system that is remote from the leak. Oxygen free nitrogen (OFN) should then be purged through the system both before and during the brazing process.

### 16.3. Check of Refrigeration Equipment

Where electrical components are to be changed, they should be fit for the intended purpose and comply with the correct specifications. Always follow the manufacturer's maintenance and service guidelines. In case of any doubt, consult the manufacturer's technical department for assistance. Check installations using flammable refrigerants.

The amount of refrigerant to be charged depends on the size of the room where the refrigerant-containing parts are installed.

- The ventilation machinery and outlets should work adequately and be not obstructed.

- If an indirect refrigerating circuit is used, the secondary circuits should be checked for any refrigerant; Markings on the equipment should be visible and legible.

- Illegible markings and signs should be corrected.

- Refrigeration pipes or components should be installed in positions where they are unlikely to be exposed to any substance that may corrode refrigerant-containing components, unless the components are constructed of materials that are inherently resistant to corrosion or are suitably protected from corrosion.

### 16.4. Check of Electrical Devices

Repair and maintenance of electrical components should include initial safety checks and component inspection procedures. If a fault exists and could compromise safety, no electrical supply should be to the circuit until it is satisfactorily dealt with.

If the fault cannot be corrected immediately but it is necessary to continue operation, an adequate temporary solution should be adopted. This should be reported to the owner of the equipment so all parties are advised. Initial safety checks should include the following:

- The capacitors should be discharged in a safe manner to avoid sparking risks.

- No live electrical components and wiring can be exposed during the system charging, recovery or purging.

- Earth bonding should be continuous.

## 16.5.Repair of Sealed Components

a)During repair of sealed components, all electrical supplies should be disconnected from the equipment being worked upon prior to any removal of sealed covers. If it is absolutely necessary to have an electrical supply connected with the equipment during servicing, a permanently operating form of leak detection should be located at the most critical point to warn of a potentially hazardous situation.

b)Particular attention should be paid to the following to ensure that, by working on electrical components, the casing is not altered in such a way that the protection is compromised. This should include damage to cables, an excessive number of connections, terminals not made as per original specifications, damage to seals, and incorrect fitting of glands.

- Ensure that all apparatuses are mounted securely. Ensure that seals or sealing materials have not degraded such that they can no longer prevent the ingress of flammable atmospheres. Parts for replacement should be in accordance with the manufacturers specifications.

- The use of silicon sealant may inhibit the effectiveness of some types of leak detection equipment.

- Intrinsically safe components do not have to be isolated prior to working on them.

## 16.6.Repair of Intrinsically Safe Components

Do not apply any permanent inductive or capacitance loads to the circuit without ensuring that such loads will not exceed the permissible voltage or current permitted for the equipment in use. Intrinsically safe components are the only types that can be worked on when the components live in a flammable atmosphere. The test apparatus should be provided with the correct rating. Replace components only with parts specified by the manufacturer. Other parts may result in the ignition of refrigerant in the atmosphere caused by a leak.

## 16.7.Transportation and Marking

Transport the equipment containing flammable refrigerants in accordance with the transport regulations.

Mark the equipment with signs in compliance with local regulations.

## 17.DISPOSAL

### General

Components and accessories of the unit are not ordinary domestic wastes.

The unit, compressors, and motors, etc. can only be disposed of by qualified specialists.

This unit uses hydrofluorocarbon that can only be disposed of by qualified specialists.

### Packaging

- Dispose of the packaging properly.
- Observe all relevant regulations.

### Refrigerant

Refer to 16.1 Refrigerant Removal, Evacuation, Charge, Recovery, and Unit Decommissioning.

## 17.1.Refrigerant Removal, Evacuation, Charge, Recovery, and Unit Decommissioning

### WARNING

*Due to the feature of the R290 refrigerant, only carry out work when you have specific expert refrigeration knowledge and are competent for handling R290 refrigerant.*

### 1) Removal and evacuation

When breaking into the refrigerant circuit for repair or any other purpose, follow the conventional procedures.

However, it is important to follow the best practice since flammability should be considered. Operate as per the following procedure:

- Remove refrigerant;
- Purge the circuit with inert gas;
- Evacuate;
- Purge the circuit again with inert gas;
- Open the circuit by cutting or brazing

The refrigerant charged should be recovered and put in correct recovery cylinders. The system should be flushed with OFN to guarantee the unit safety. This process may need to be repeated several times. Compressed air or oxygen should not be used.

Flushing should be achieved by filling the system with OFN until the working pressure is achieved before venting to the atmosphere, and recovering the system to a vacuum. This process should be repeated until no refrigerant exists in the system.

Upon the final OFN charge, the system should be vented down to reach the atmospheric pressure to start the work.

This operation is absolutely vital if brazing operations on the pipe-work are to take place.

Ensure that the outlet of the vacuum pump is not closed to any ignition sources and adequate ventilation is available.

## 2) Charging procedures

In addition to conventional charging procedures, the following requirements should be followed:

- Ensure that contamination of different refrigerants does not occur when charging equipment is used. Hoses or lines should be as short as possible to minimize the amount of refrigerant contained in them.
- Earth the refrigeration system prior to charging the system with refrigerant.
- Label the system upon completion of the charging (if the system has not been labeled).
- Extreme care should be taken not to overfill the refrigeration system.
- Prior to recharging the system, test it with OFN.

The system should be leak tested upon completion of charging but prior to commissioning. Carry out a follow-up leak test before leaving the site.

## 3) Recovery

When removing refrigerant from the system, either for service or decommissioning, we recommend you remove all refrigerants safely by following the best practice.

When transferring refrigerant into cylinders, only use appropriate refrigerant recovery cylinders. Ensure that a proper number of cylinders are available for accommodating all the refrigerant. All cylinders to be used are designated and labeled for the recovered refrigerant (i.e., special cylinders for the recovery of refrigerant). The cylinders should be complete with pressure relief valves and associated shut-off valves that work properly.

Empty recovery cylinders should be evacuated and, if possible, cooled before the recovery starts.

The recovery equipment should work properly with a set of instructions concerning the equipment at hand, and should be suitable for the recovery of flammable refrigerants. In addition, a set of calibrated weighting scales should be available and work properly. Hoses should be complete with leak-free disconnection couplings and in good conditions. Before using the recovery equipment, check and verify that it works properly and has been properly maintained, and that any associated electrical components are sealed to prevent ignition in the event of a refrigerant leakage. Consult the manufacturer in case of any doubt.

The recovered refrigerant should be returned to the refrigerant supplier in correct recovery cylinders, with the relevant Waste Transfer Note arranged. Do not mix refrigerants in recovery units, especially in cylinders.

If compressors or compressor oils are to be removed, ensure that they have been evacuated to an acceptable level to ensure that flammable refrigerant does not

remain within the lubricant. Carry out the evacuation process before returning the compressor to the suppliers. To accelerate this process, you can only heat the compressor body electrically. Safety drain oil from the system.

## 4) Decommissioning

Prior to this procedure, the technician should be completely familiar with the equipment and all its details. It is recommended that all refrigerants be recovered safely. Prior to the recovery, an oil and refrigerant sample should be taken for case analysis before re-use of reclaimed refrigerant. Electrical power should be available before the task is commenced.

- Be familiar with the equipment and its operation.
- Isolate the system electrically
- Before attempting the procedure ensure that:
  - Mechanical handling equipment is available, if required, for handling refrigerant cylinders.
  - All personal protective equipment should be available and used correctly.
  - The recovery process should be supervised at all time by a competent person.
  - Recovery equipment and cylinders should conform to the appropriate standards.
- Pump down the refrigerant system, if possible.
- If a vacuum is not possible, provide a manifold to remove the refrigerant from various parts of the system.
- Make sure that the cylinders are situated on the scales before the recovery starts.
- Start the recovery machine and operate it in accordance with the manufacturer's instructions.
- Do not overfill the cylinders (for no more than 80% of the volume).
- Do not exceed the maximum working pressure of the cylinders, even temporarily.
- When the cylinders have been filled correctly and the process is completed, immediately remove the cylinders and the equipment from the site and close all isolation valves on the equipment.
- The recovered refrigerant should not be re-used in any other refrigeration system unless it has been cleaned and checked.

### NOTE

*In case of any concern:  
Contact the local dealer for further information about refrigerant removal, evacuation, charge, and recovery of the R290 refrigerant,  
Contact the local dealer for further information about unit decommissioning.*



## 18. TECHNICAL DATA

### 18.1. General

Model	1-phase 4/6 kW	1-phase 8/10 kW	1-phase 12/14/16 kW	3-phase 12/14/16 kW
Nominal capacity	Refer to the Technical Data			
Dimensions H×W×D	717*1299*426 mm	865*1385*523 mm	865*1385*523 mm	865*1385*523 mm
Packing dimensions H×W×D	885*1375*475 mm	1035*1465*560 mm	1035*1465*560 mm	1035*1465*560 mm
Weight (without backup heater)				
Net weight	90 kg	117 kg	135 kg	137 kg
Gross weight	110 kg	139 kg	157 kg	159 kg
Weight (with backup heater)				
Net weight	95 kg	122 kg	140 kg	142 kg
Gross weight	115 kg	144 kg	162 kg	164 kg
Connections				
Water inlet/outlet	G1"BSP	G1 1/4"BSP	G1 1/4"BSP	G1 1/4"BSP
Water drain	Hose nipple			
Expansion vessel				
Volume	8 L			
Maximum working pressure (MWP)	8 bar			
Pump				
Type	Water cooled	Water cooled	Water cooled	Water cooled
No. of speed	Variable speed	Variable speed	Variable speed	Variable speed
Pressure relief valve in water loop	3 bar			
Operation range - water side				
Heating	+12 to +75°C			
Cooling	+5 to +25°C			
Operation range - air side				
Heating	-25 to 35°C			
Cooling	-5 to 46°C			
Domestic hot water by heat pump	-25 to 46°C			
Refrigerant				
Refrigerant type	R290			
Refrigerant charge	0.7 kg	1.1 kg	1.25 kg	1.25 kg

Fuse – on PCB		
PCB name	Main control board	Inverter module
Model name	FUSE-T-10A/250VAC-T-P	FUSE-T-30A/250VAC-T-P-HT
Working voltage (V)	250	250
Working current (A)	10	30

### 18.2. Electrical Specifications

Model		4	6	8	10	12	14	16	12	14	16
Standard unit	Power Supply	1P/220-240V/50Hz						3P/380-415V/50Hz			
	Nominal Running Current (A)	16	16	20	20	31	31	31	11	11	11
Backup heater	Power Supply	1P/220-240V/50Hz						3P/380-415V/50Hz			
	Nominal Running Current (A)	13.5						13.5			

## 18.3.Piping Diagram

### 4-6 kW units (without electric heater)

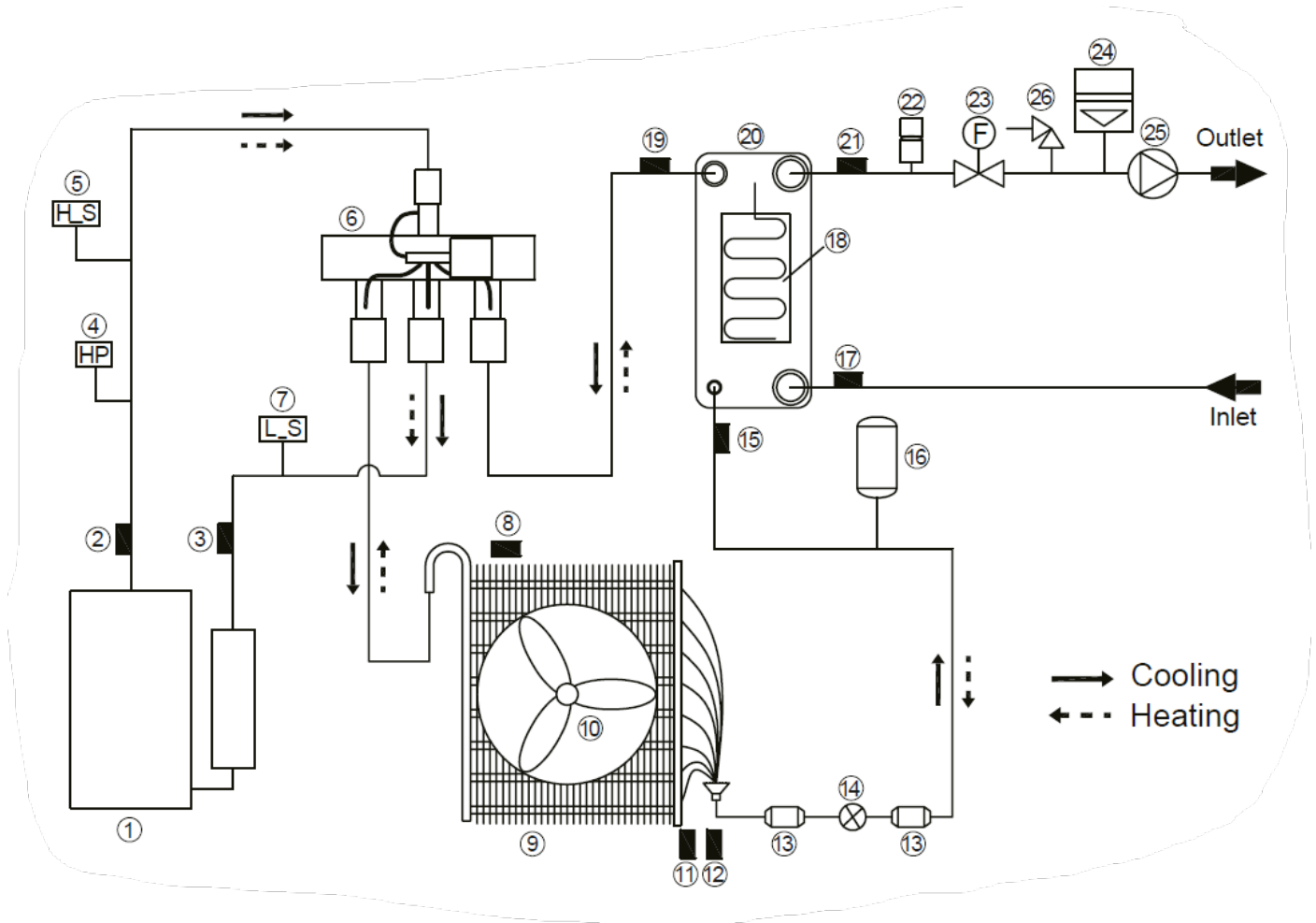

Item	Description	Item	Description
1	Compressor	14	Electronic expansion valve
2	Temperature sensor (compressor discharge)	15	Temperature sensor (plate heat exchanger inlet refrigerant: cooling)
3	Temperature sensor (compressor suction)	16	Liquid reservoir
4	High pressure switch	17	Temperature sensor (water inlet)
5	High pressure sensor	18	Heat tape (plate heat exchanger)
6	4-way valve	19	Temperature sensor (plate heat exchanger outlet refrigerant: cooling)
7	Low pressure sensor	20	Plate heat exchanger
8	Temperature sensor (outdoor air)	21	Temperature sensor ( water outlet)
9	Heat exchanger	22	Automatic air vent valve
10	Fan	23	Water flow switch
11	Temperature sensor (heat exchanger)	24	Expansion vessel
12	Temperature sensor (heat exchanger outlet refrigerant: cooling)	25	Water pump
13	Filter	26	Pressure relief valve

## 4-16 kW (With electric heater)

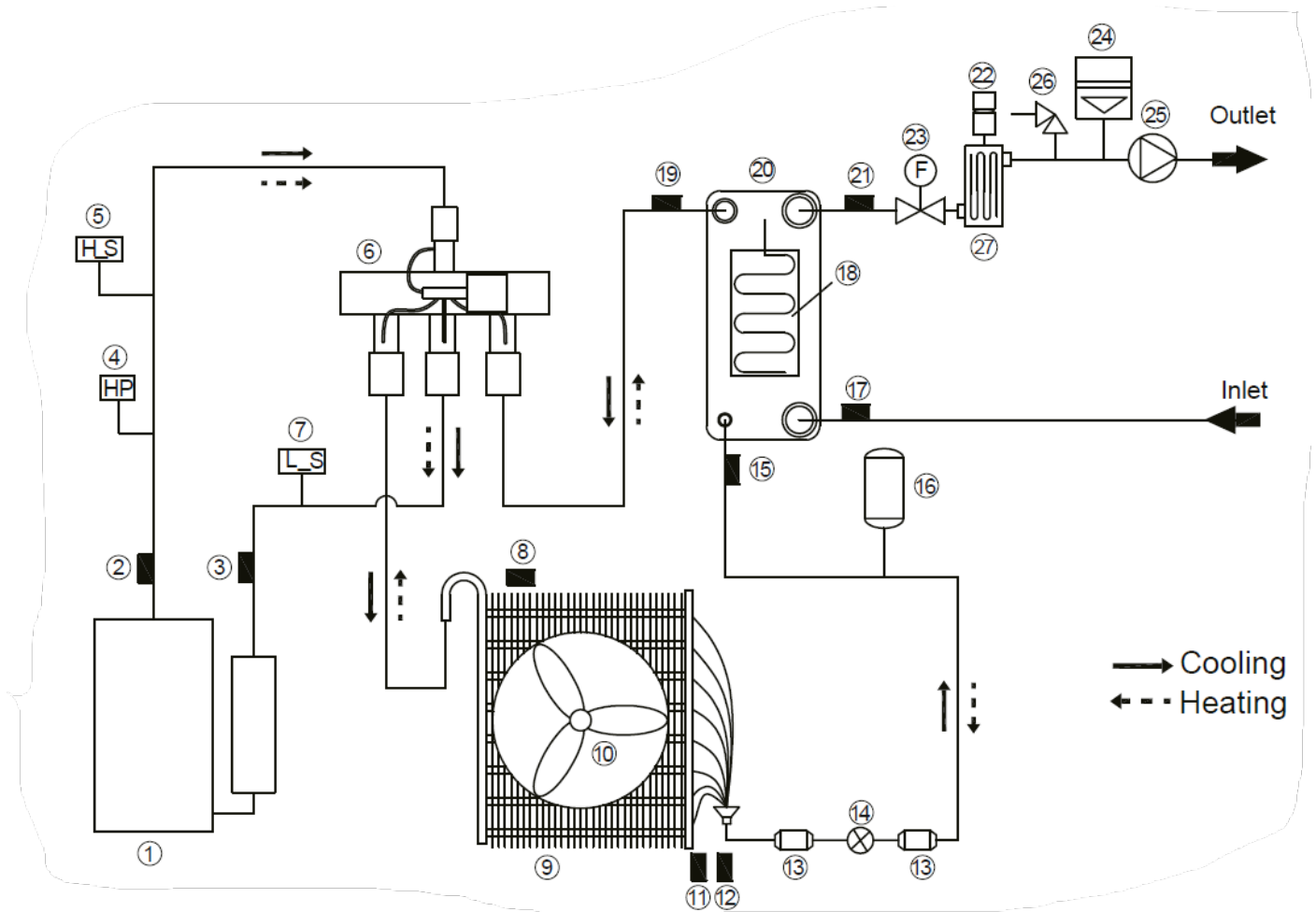

Item	Description	Item	Description
1	Compressor	14	Electronic expansion valve
2	Temperature sensor (compressor discharge)	15	Temperature sensor (plate heat exchanger inlet refrigerant: cooling)
3	Temperature sensor (compressor suction)	16	Liquid reservoir
4	High pressure switch	17	Temperature sensor (water inlet)
5	High pressure sensor	18	Heat tape (plate heat exchanger)
6	4-way valve	19	Temperature sensor (plate heat exchanger outlet refrigerant: cooling)
7	Low pressure sensor	20	Plate heat exchanger
8	Temperature sensor (outdoor air)	21	Temperature sensor (water outlet)
9	Heat exchanger	22	Automatic air vent valve
10	Fan	23	Water flow switch
11	Temperature sensor (heat exchanger)	24	Expansion vessel
12	Temperature sensor (heat exchanger outlet refrigerant: cooling)	25	Water pump
13	Filter	26	Pressure relief valve
		27	Backup heater

## 8-16 kW units (without electric heater)

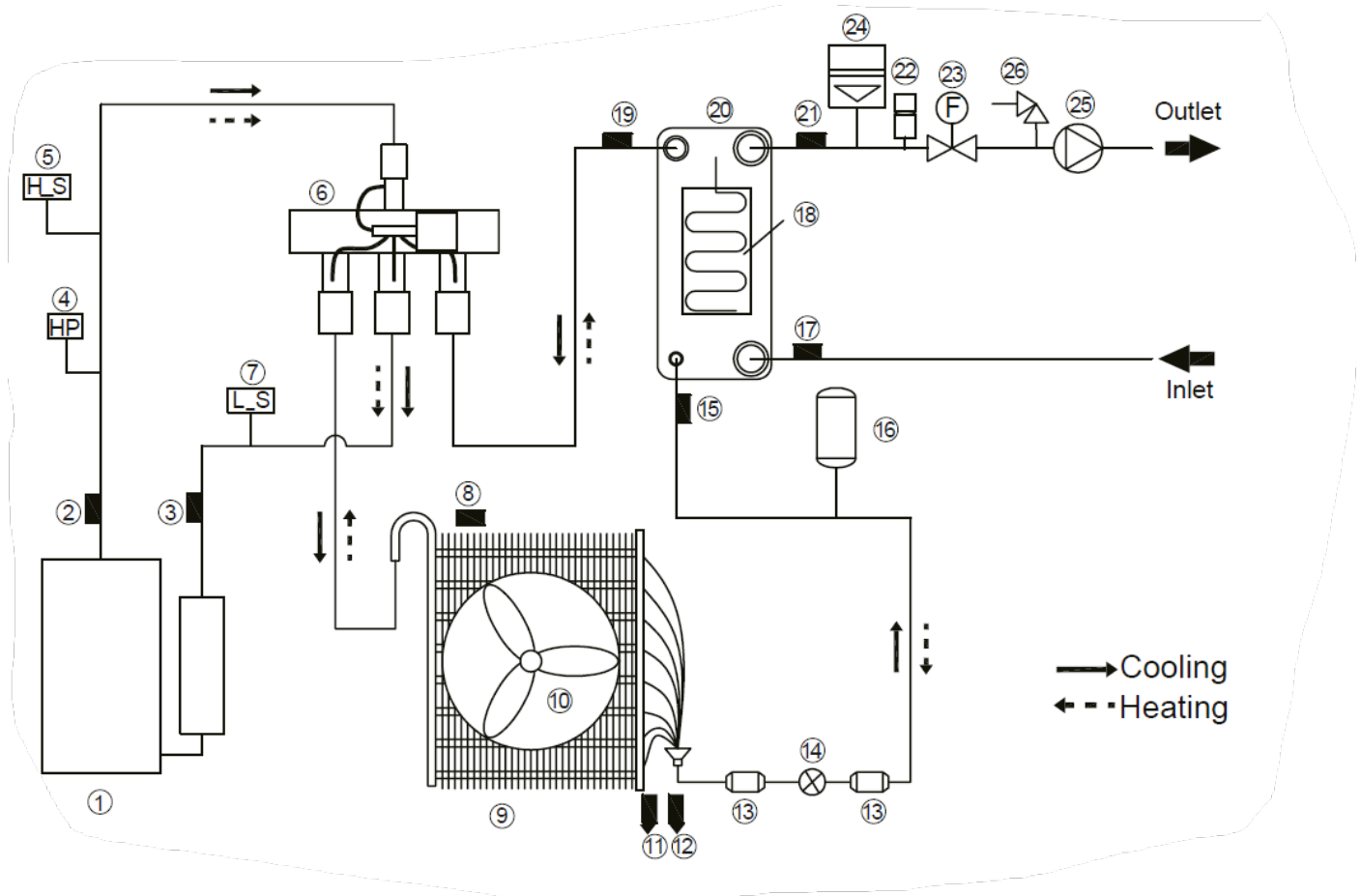

Item	Description	Item	Description
1	Compressor	14	Electronic expansion valve
2	Temperature sensor (compressor discharge)	15	Temperature sensor (plate heat exchanger inlet refrigerant: cooling)
3	Temperature sensor (compressor suction)	16	Liquid reservoir
4	High pressure switch	17	Temperature sensor (water inlet)
5	High pressure sensor	18	Heat tape (plate heat exchanger)
6	4-way valve	19	Temperature sensor (plate heat exchanger outlet refrigerant: cooling)
7	Low pressure sensor	20	Plate heat exchanger
8	Temperature sensor (outdoor air)	21	Temperature sensor ( water outlet)
9	Heat exchanger	22	Automatic air vent valve
10	Fan	23	Water flow switch
11	Temperature sensor (heat exchanger)	24	Expansion vessel
12	Temperature sensor (heat exchanger outlet refrigerant: cooling)	25	Water pump
13	Filter	26	Pressure relief valve

## 19.ANNEX

### 19.1.Menu Structure (Wired Controller)

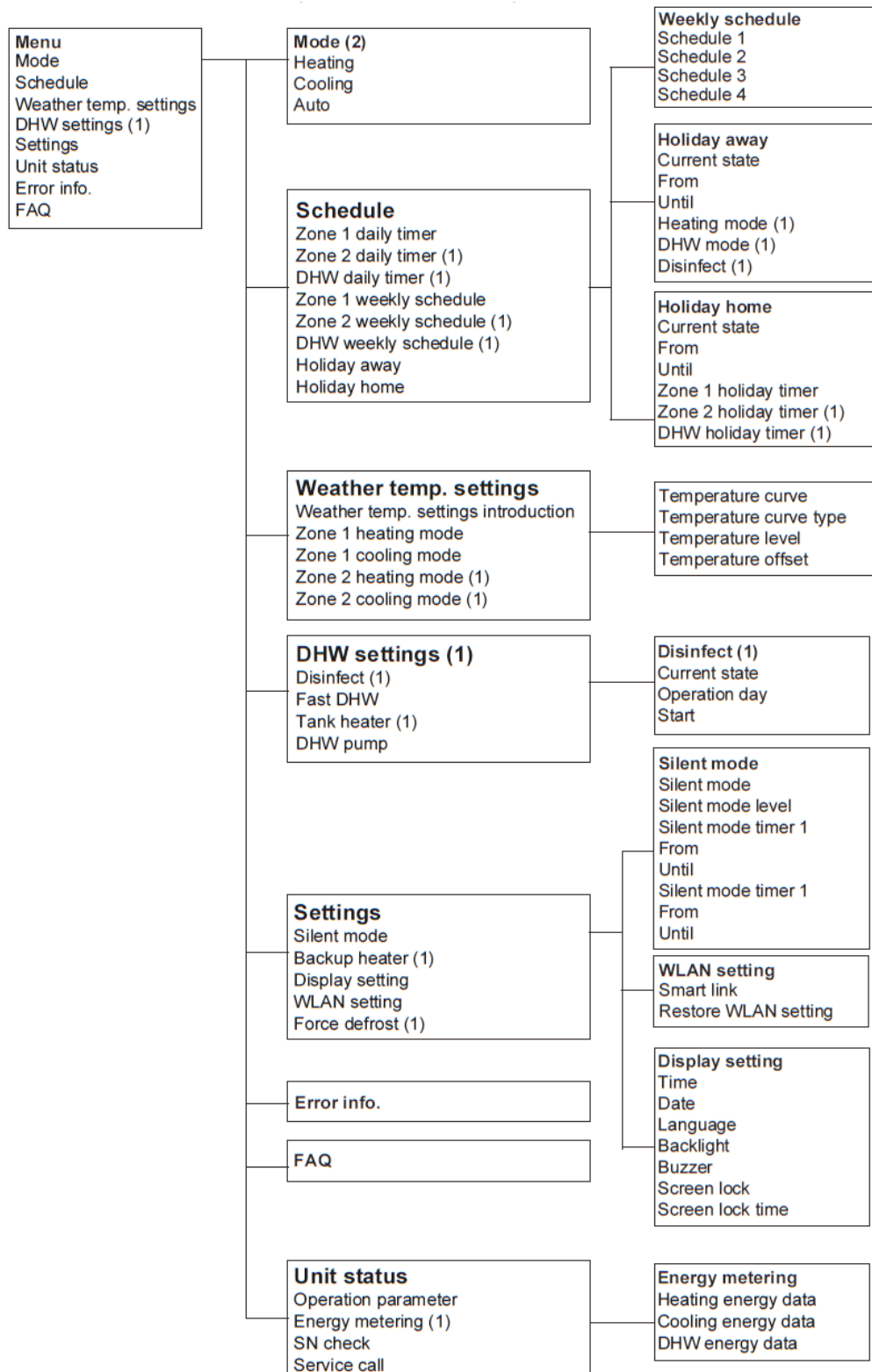

(1) Invisible if corresponding function is disabled.

(2) The layout could be different if the corresponding function is disabled or enabled.

There are also some other items that are invisible if the function is disabled.

For serviceman

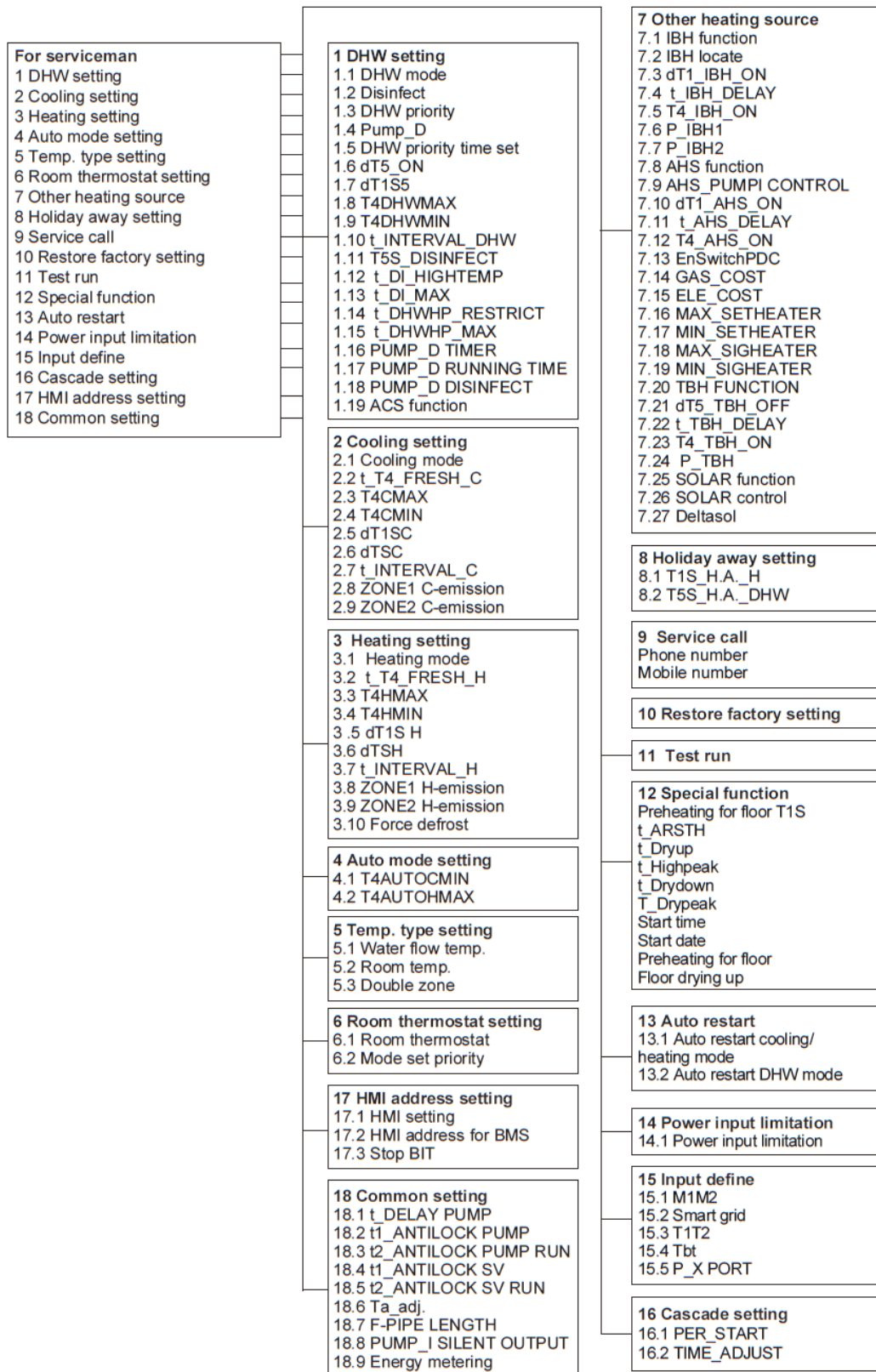



**GROUPE AIRWELL**  
**10 RUE DU FORT DE SAINT CYR**  
**78180 MONTIGNY LE BRETONNEUX**  
**FRANCE**  
[www.airwell.com](http://www.airwell.com)