

Airwell



FRENCH BRAND

2023/2024 HEAT PUMPS, AIR CONDITIONING & RENEWABLE ENERGY EUROPE SOLUTIONS



OUR MOST
BEAUTIFUL ENERGY
STORY IS YOU

W
E
L
L
Z
G
R
E
M
S
A
R
T

Let's prepare for the future of energy... together

A French expert and creator of HVAC solutions for over 75 years, Airwell's mission has always been to create and cultivate well-being, and is now committed to helping drive the energy transition.

TABLE OF CONTENTS

p.6 Our values

p.8 Service division

p.10 Airwell Academy

p.15 VRF range

Just feel smart

SMART RANGE

p.19 SMART BUILDING & SMART HOME SOLUTIONS

p.20 Hybrid house

p.22  AirHome APP

p.24  AirConnect Pro APP - WELLEA range

Just feel green

SOLAR RANGE

p.27



Solar panels				• Photovoltaic
Electrical boxes				• Single-phase AC 6 kW & Three-phase AC 9 kW
Micro-inverters				• DS3-L & DS3
Pitched roof kits				• Fastening hooks and rails
Photovoltaic pack				• AirSolar solutions offer

Just feel well

AIR/WATER RANGES

p.31 HEAT PUMP RANGE



p.32 WELLEA WT R32 • Triple-service split heat pump

p.34  WELLEA Split R32 • Split heat pump

p.36 WELLEA Monoblock R32 • Monoblock heat pump

p.38 WELLEA Monoblock DF R32 • Monoblock heat pump

p.41 DOMESTIC HOT WATER PRODUCTION RANGE

p.42  TFHX  R134A • Split thermodynamic water heater

p.44 TFHW  R134A • Monoblock thermodynamic water heater

p.46 TFHZ  R134A • Solar thermodynamic water heater

p.48 Domestic hot water production kits

p.50 Heating and DHW accessories

AIR/AIR RANGES

p.53 HIGH WALL RANGE

p.54 HDHC Artica  R32 • High wall - High efficiency

p.56  HDMB Harmonia R32 • High wall - Colour range

p.58 HDLA R32 • High wall

p.60 HDLE Aura R32 • High wall - Built-in Wi-Fi

p.63 MULTISPLIT RANGE

p.64  ZDAA R32 • Multisplit

p.76 ZDAE R32 • Multisplit

p.85 CONSOLE, FLOOR CEILING & FLOOR STANDING RANGES

p.86		XDLF		R32	• Dual-flow console
p.88		XDMX		R32	• Dual-flow console
p.90		FDMX		R32	• Floor ceiling
p.92		FDLK		R32	• Low-temperature floor ceiling
p.94		SDMX		R32	• Floor standing

p.97 DUCTED RANGE

p.98		DDMX		R32	• Medium-pressure ducted
p.100		WELLZONE			• Zone-by-zone regulation

p.103 VENTILATION RANGE

p.104		JDAA Airflow		R32	• Thermodynamic dual-flow CMV
--------------	---	--------------	---	-----	-------------------------------

p.107 CASSETTE RANGE

p.108		CDMX		R32	• 360° cassette
--------------	--	------	--	-----	-----------------

p.111 MONOBLOCK RANGE

p.112		XDAW		R32	• Monoblock console - Built-in Wi-Fi
p.113		WFAE		R32	• Window
p.114		MFH		R290	• Portable - Cooling only

p.117 WATER-COOLED RANGE

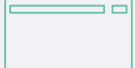
p.118		XDOW		R410A	• Water-cooled console
p.120		DFMO		R410A	• Water-loop heat pump

p.123 CONTROL SYSTEMS

p.124		Compatibility tables			
p.125		Function tables			
p.126		Remote controls			

p.142	Technical draws
p.168	Installation accessories
p.169	Toolbox (installation assistance, recommendations...)
p.192	General terms and conditions of sale
p.194	Icon guide

Airwell

YOUR FRENCH REFERENCE
for over 75 years

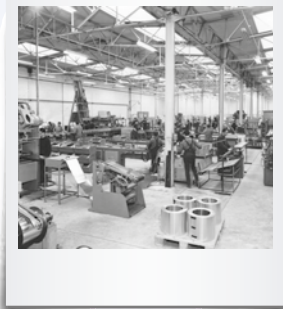

Airwell, a French thermal equipment manufacturer committed to the energy transition

A French referenced brand for professionals

As an expert and creator of climate and thermal solutions, Airwell's mission is to create and cultivate well-being. Airwell is committed to:



Reinventing uses

→ To limit our environmental footprint.



Optimising consumption

→ To consume less and better.



Promoting solar energy

→ To preserve natural resources.

Historical French manufacturer

- 1947 ● Creation of the Airwell Group, the French pioneer in heat pumps.
- 1970 ● Airwell becomes the leading European heat pump manufacturer. Leader in Europe and Africa.
- 2008 ● Industrial disengagement and restructuring of the Airwell Group.
- 2014 ● Launch of the Airwell 2.0 strategic project (the transformation from a heat pump manufacturer to a solution provider).
- 2020 ● Launch of Hybrid House, AirConnect Pro and Leezy.
- 2021 ● Airwell becomes Airwell Group following the acquisition of Airwell Residential by Airwell Distribution.
- 2022 ● Integration of the CSR approach into the strategy and award of the "Innovative Company" label by BPI France.

GRUPE AIRWELL



INNOVATION · SERENITY · COMFORT LISTENING · COMMITMENT

Airwell manifesto

A vision for the future.

This is how Airwell was born in 1947. With the crazy idea of bringing innovative solutions from the United States that did not yet exist in Europe: air conditioning.

Today, innovation is more than ever at the heart of Airwell, as we have become leaders in the creation of thermal and climatic solutions. A deeply human innovation, listening to consumers.

Just like the family spirit that defines Airwell, based on wellbeing and respect for everyone's expectations.

Optimising our energy consumption, favouring solar energy to preserve our natural resources, reinventing consumer uses to limit our environmental footprint, cultivating the comfort of each interior...

At Airwell, we are committed to this for the well-being of everyone and the environment.

"What was our ambition became our mission."

Yes, energy solutions must be intuitive in their management and use.

Yes, they must reduce the ecological and economic impact of housing.

Yes, the world of tomorrow must be built around a single principle: the serenity of each individual.

"And we are convinced of this."

Our most beautiful energy story is you.

72
employees

200+
business partners

70+
service partners

Airwell operates in
80
countries

WANT TO INVEST AND BECOME A CONTRIBUTOR IN THE ENERGY TRANSITION?

A propitious context:



I BECOME A SHAREHOLDER

All the steps are detailed on our website:

<https://groupe-airwell.com/en/become-a-shareholder/>

AFTER-SALES AND QUALITY SERVICE



+33 (0)1 76 21 82 95

Monday to Friday 9 am-1230 pm / 2 pm-5 pm

ORDER SPARE PARTS

sp@airwell.com

TECHNICAL SUPPORT

sav@airwell.com

We want our customers to be satisfied with our services, which is why our teams constantly monitor our spare parts stock.

Our interactive voice server (IVR) has been redesigned in order to provide a more efficient and effective customer service. Our responsiveness and professionalism provide a benchmark level of service.

SERVICES DEDICATED TO MAKING YOUR LIFE EASIER

Do you need technical assistance in determining the right parts, wiring diagrams or even fault codes for you?

Our hotline, based in France, is ready to support you and help solve all your problems.

Contact our project experts:

presales@airwell.com

TECHNICAL DOCUMENTATION

You can access all of our documentation from our online library:

<https://lh.airwell-res.com/>



TECHNICAL SUPPORT AND PROJECTS

TO CONTACT OUR EXPERTS

presales@airwell.com • **+33 (0)1 76 21 82 82**

Enjoy the advantages of a remote sales specialist while retaining your discount!

MORE THAN 75 YEARS OF EXPERTISE AT YOUR SERVICE

LOCAL AND REMOTE TECHNICAL SERVICE

- Specialist technicians.
- Direct contact by phone and on-site if necessary.
- Training in all products.
- Commissioning carried out by an Airwell-approved Technical Centre.

CALL CENTRE

- Quick and effective responses from our experts.
- High availability.
- A multilingual centre.
- Continuously trained professionals.
- A customer and service-focused approach first and foremost!
- Attentive assistance until the customer is fully satisfied.

+33 (0)1 76 21 82 95

You can find all our partners on our website, via the link below:

<https://www.airwell.com/en/where-to-find-us/>



VIDEO ASSISTANCE

Customers are ever more demanding. Our mission is to support you in meeting their needs, and facilitate your work. That is why we provide remote technical assistance.

You can consult our experts from the field, by sharing your phone's camera in real time, as well as photos or technical manuals, in addition to the voice channel.

The advantages of our After-Sales and troubleshooting assistance solution:

- An instructive and easy-to-use medium.
- Significantly increases the first-time resolution rate.
- Shorter response times on the ground.
- Call handled in our telephony system, to ensure continuous improvement of our services.



OUR TECHNICAL EXPERTS ARE AT YOUR DISPOSAL

From Monday to Friday 8 am to 6 pm



+33 (0)1 76 21 82 95



Airwell ACADEMY

WHY AIRWELL ACADEMY?

AIRWELL had to provide a solution!

- ▶ Technical & qualifying training.
- ▶ Training tools: training rooms and training trolley rental service.
- ▶ Tailored services: residential and industrial energy audit.

Airwell supports you in setting up an energy management system that is essential to your business and to the planet.

Register for the training program at:
www.airwell-academy.fr

THE CENTRES

THE TRAINING SPACE PROVIDES:

- An Airwell products showroom
- Several equipped training rooms
- An habilitation room
- A dining area and a kitchen
- An outdoor recreational area
- Private car park

CONTACT US

NEW!

THE TRAINING CENTRE IN PARIS, FRANCE:

Airwell Academy

10, rue du Fort de Saint Cyr
78180 Montigny-le-Bretonneux, France

This center is specialized in energy engineering field retraining.

THE TRAINING CENTRE IN VALENCE, FRANCE:

Airwell Academy

66, rue Gilles de Roberval - 26000 Valence, France



airwell-academy@airwell.com

+33 (0)1 76 21 82 22









or contact your Airwell sales representative



TRAINING *Guide*



Airwell offers training services to develop your knowledge of products and the market environment**.

<p>RES01</p> <p>Technical training RESIDENTIAL APPLICATION</p> 	<p>DRV01</p> <p>Technical training VRF APPLICATION</p> 	<p>PAC01</p> <p>Technical training HEAT PUMP APPLICATION</p> 
<p>HA01</p> <p>Qualification training ELECTRICAL QUALIFICATION FOR AIR CONDITIONING BUSINESSES</p> 	<p>MET01</p> <p>Qualification training REFRIGERANT HANDLINGS</p> 	<p>FL01</p> <p>Qualification training CAT 1 APTITUDE CERTIFICATE – NON-EXPERIENCED TECHNICIAN</p> 
<p>QUALIT ENR01</p> <p>Qualification training QUALIPAC HEAT PUMPS & DHW</p> <p>RGE RECONNU GARANT ENVIRONNEMENT</p> 	<p>QUALIT ENR02</p> <p>Qualification training QUALIPV SOLAR PHOTOVOLTAIC</p> <p>RGE RECONNU GARANT ENVIRONNEMENT</p> 	<p>QUALIT ENR03</p> <p>Qualification training QUALISOL CESI (CETIAT PARTNERSHIP)</p> <p>RGE RECONNU GARANT ENVIRONNEMENT</p> 

* Score derived from customer satisfaction surveys of trainees from between 06/15/2021 and 10/28/2022.

** The qualifying modules are qualifying training for the French market, in line with French regulations.

NEED EQUIPMENT OR A TECHNICAL PLATFORM FOR YOUR TRAINING?

TAILORED TROLLEYS

Our mission as climate engineering professionals is to support the trainees in the sector, and give them the means to upskill.

Climate engineering plays a major role in the training of the specialists and engineers.

This is why we have developed teaching equipment in the form of training trolleys, made in France, on which our products operate.

We offer a multitude of teaching equipment, tailored to Airwell products or custom-made.



ROOM RENTAL

The Airwell Academy offers a rental service for its rooms, which are essential in teaching good practice in the refrigeration sectors.

Quote and booking:

airwell-academy@airwell.com

+33 (0)1 76 21 82 22

www.airwell-academy.fr

A series of horizontal dotted lines across the page, providing a template for writing or listing items.

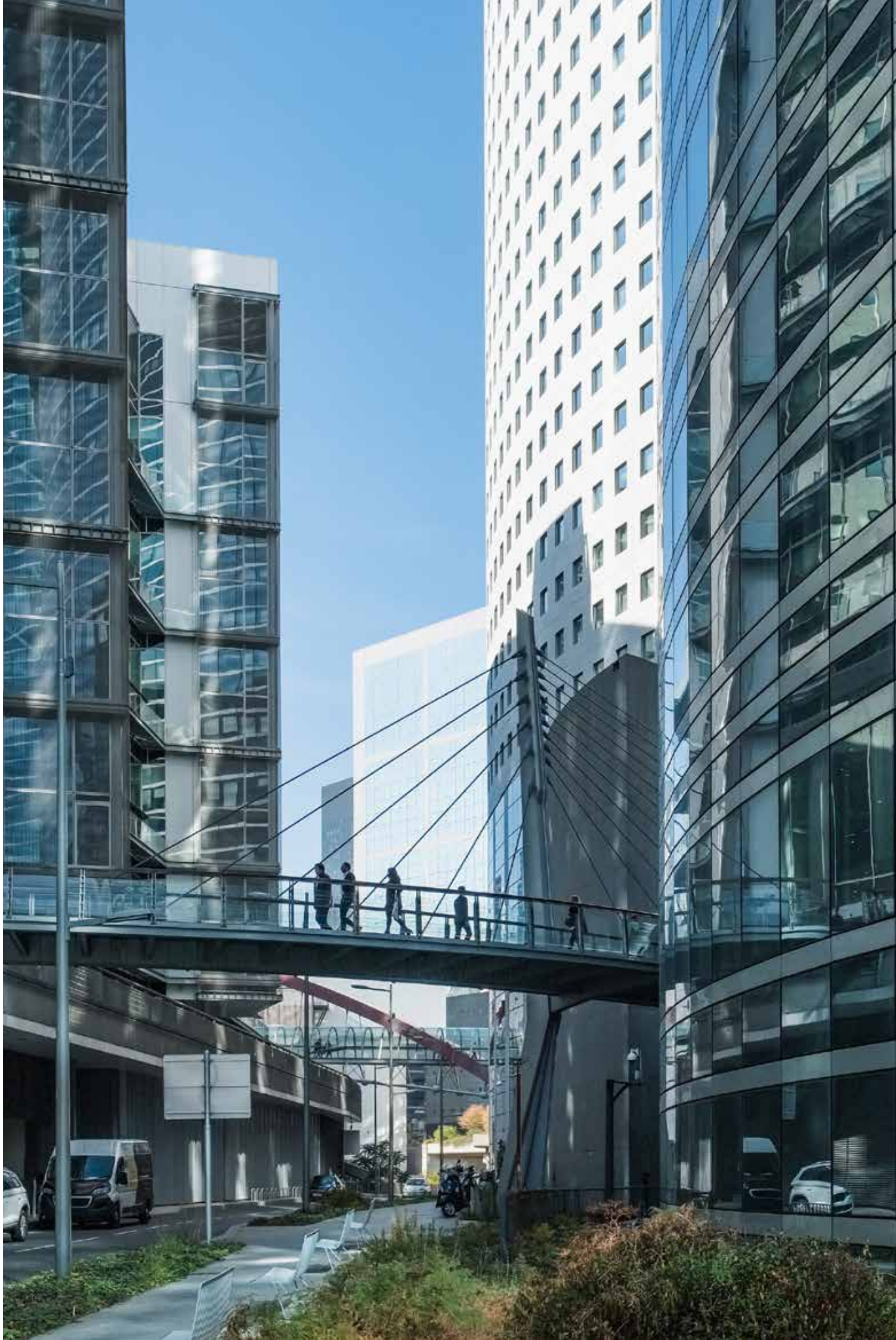

COMMERCIAL & INDUSTRIAL

Ranges

THE AIRWELL VRF SOLUTION

A manufacturing concept built on experience and an international presence.

Product designed to meet European energy efficiency prerogatives while being resistant to harsh climatic environments.

Airwell VRFs are 100% Inverter

The new VRF Inverter range exclusively uses the best Japanese compressor brands and focusing on 3 technologies: the **Scroll EVI, the Scroll and the Twin Rotary**, thus offering a perfect ratio between reliability and energy efficiency.

All the refrigeration units of the Airwell VRFs have been strictly selected to guarantee flawless reliability and increased service life.

Among the most notable refrigeration components are the Japanese compressors and the oversized "anti-liquid shock" bottle protecting it. An oil separator per compressor allowing a direct return of more than 95% of the oil expelled during discharge and a sub-cooler with an adjustable target during development.

In addition, each Airwell VRF is protected by a series of sensors allowing the correct operation and energy efficiency of the installation to be guaranteed at all times.

Airwell communication bus

Thanks to the disconnection of the indoor units, it allows the system to remain in operation, offering greater comfort to end customers during service and maintenance operations.

Silent mode

Silent mode allows installation in restricted urban areas.

Anti-corrosion treatment

Standard anti-corrosion treatment offering resistance to salt spray for more than 1500 hours and reinforced anti-corrosion treatment on request to meet the most demanding constraints.

**Look up our VRF catalogue for details
of our various ranges.**



OUTDOOR UNIT MODELS

REFRIGERANT
TYPECAPACITY
(HP)COOLING CAPACITY
(kW)HEATING CAPACITY
(kW)

VVFA - 2-PIPES - FRONT DISCHARGE



VVFA-125R

4

12.10

14.20

VVFA-150R

6

15.50

18.00

VVFA-220R

R410A

8

22.60

22.60

VVFA-280R

10

28.00

30.50

VVFA-335R

12

31.50

31.50

VVTA - 2-PIPES - TOP DISCHARGE



VVTA-400R

14

40.00

40.00

VVTA-450R

16

45.00

45.00

VVTA-504R

R410A

18

50.40

50.40

VVTA-560R

20

56.00

56.00

VVTA-680R

24

68.00

68.00

VVTA-735R

26

73.50

73.50

VVEA - 3-PIPES - TOP DISCHARGE



VVEA-335R

12

33.50

33.50

VVEA-400R

14

40.00

40.00

VVEA-450R

16

45.00

45.00

VVEA-504R

R410A

18

50.40

50.40

VVEA-560R

20

56.00

56.00

VVEA-615R

22

61.50

61.50

The indoor units of the VRF range adapt to all destinations and all projects. From the 4-way cassette to the 360° cassette, from the extra-flat duct to the high-pressure duct and from the wall to the ceiling-light, Airwell meets all the needs in terms of thermal comfort.

- ▶ Fitted with DC inverter fan motors offering high aerodynamic performance with a very low sound level and an electronic expansion valve offering 475 opening steps, the indoor units in the range will combine **comfort and performance**.
- ▶ The entire range of indoor units offers a **standard dry contact** allowing the unit to be controlled through a window or door contact or a “room card” for a hotel application.
- ▶ At Airwell, each indoor unit is delivered with its RWV05 wired or RCV03 infrared remote control.

INDOOR UNIT MODELS			REFRIGERANT TYPE	CAPACITY (HP)	COOLING CAPACITY (KW)	HEATING CAPACITY (kW)
	HIGH WALL	HVVA	R410A	7 models		
				0.75 to 3.75	2.2 to 9.0	2.5 to 10.0
	CASSETTE 600X600	CVQA	R410A	6 models		
				0.5 to 2.25	1.5 to 5.6	1.7 to 6.3
	360° CASSETTE	CVTA	R410A	7 models		
				1.75 to 7.0	4.5 to 16.0	5.0 to 18.0
	FLOOR CEILING	FVVA	R410A	8 models		
				1.5 to 6.0	6.3 to 14.0	4.0 to 16.0
	DUCTED LOW STATIC PRESSURE	DVLA	R410A	4 models		
				0.75 to 1.75	2.2 to 4.5	2.5 to 5.0
	MEDIUM-PRESSURE DUCTED	DVMA	R410A	10 models		
				0.5 to 7.0	1.5 to 16.0	1.7 to 18.0
	DUCTED HIGH STATIC PRESSURE	DVHA	R410A	2 models		
				9 and 24	22.6 and 28	25.0 and 31.5
	CONSOLE	XVVA	R410A	3 models		
				1.25 to 2.25	2.8 to 5.6	3.2 to 6.3
	AHU CONNECTION KIT			14 models		
				-	-	7 to 73

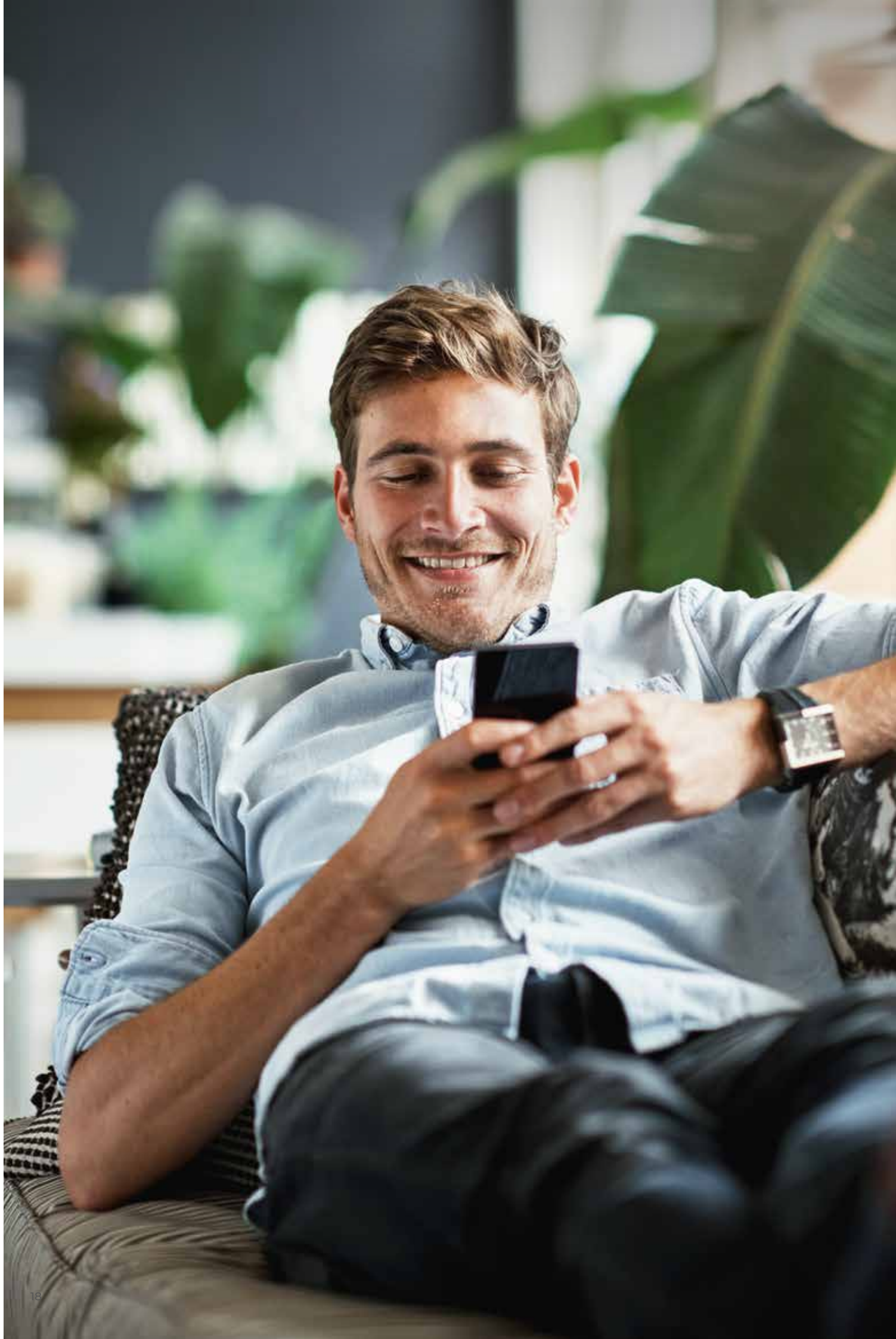

SMART BUILDING & SMART HOME

Solutions

MODEL

p.20

HYBRID HOUSE



p.22

AIRHOME APP



p.24

AIRCONNECT PRO APP - WELLEA RANGE



HYBRID

HOUSE by Airwell

Hybrid House by Airwell is the combination of the energy performance of heating products/ heat pumps/air conditioning powered by photovoltaic energy; all controlled in an intelligent, connected and centralized system.

GOING HYBRID *at your own pace!*

This is about creating the configuration that meets the customer's use and budget.

1

YOU PRODUCE YOUR OWN ENERGY

With AirSolar photovoltaic solar panel kits and Dual Sun hybrid technology, you produce free energy (electricity and/or hot water) allowing you to make big savings. In addition, this energy allows you to minimize the carbon footprint (green energy).

AirSolar
SOLUTIONS
AN AIRWELL GROUP BRAND

2

YOU POWER ALL THE EQUIPMENT IN YOUR HOME

This energy produced makes your home more energy self-sufficient, as it is able to power the heating, air conditioning, ventilation, domestic hot water production and other equipment in your home*.

* Under development for 2023.

3

CONTROL OF YOUR EQUIPMENT AT YOUR FINGERTIPS



The AirHome APP allows you to control your energy appliances from your

smartphone and tablet. Hence, controlling your consumption has never been so easy!



VISIT THE WEBSITE

Video, explanation of concept, map of approved installers network.



H APPROVED INSTALLER
HYBRID HOUSE by *Airwell*

Our approved installers network really got around this year!

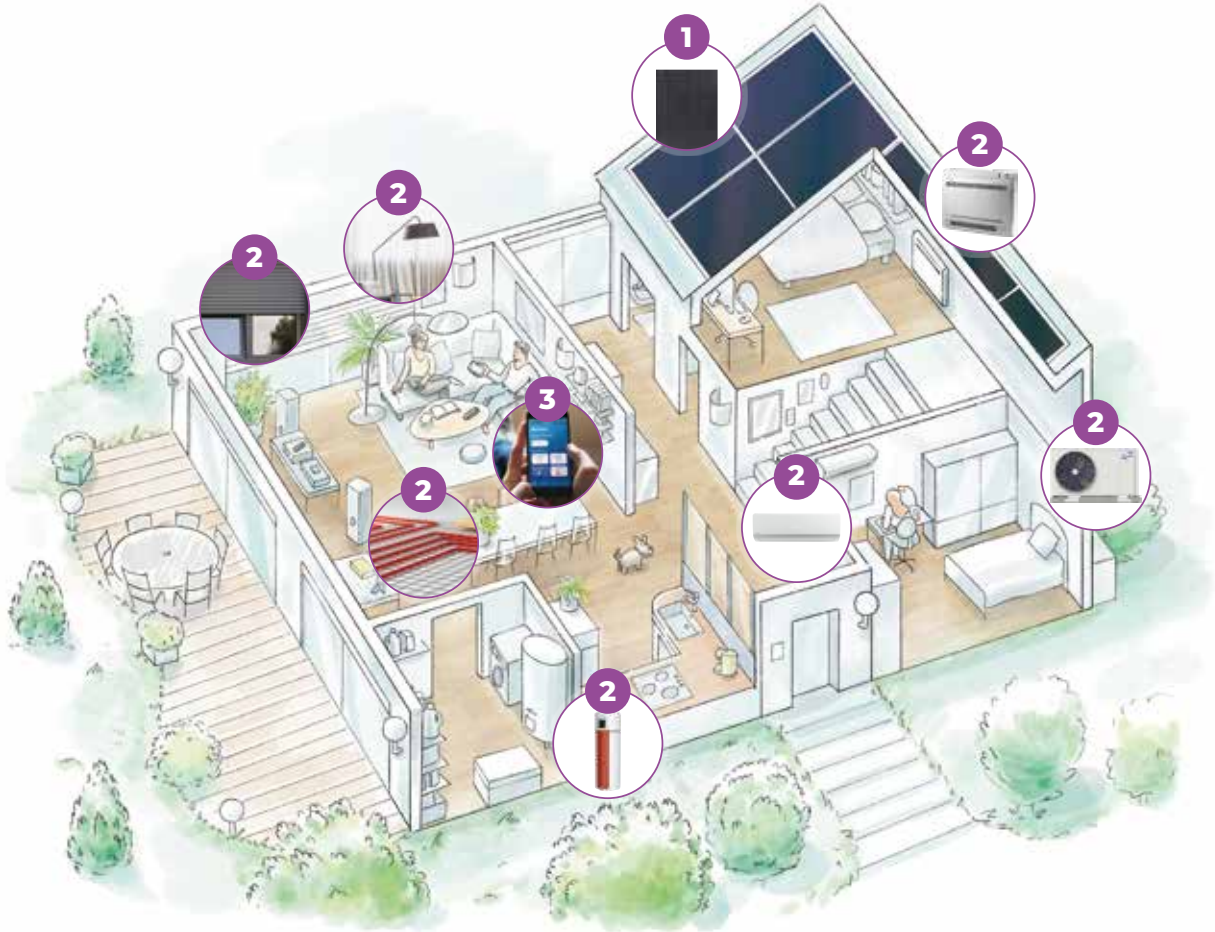

Thanks to our free **AirHome** app, available on Android and iOS, welcome to the Airwell hybrid and connected home!



CONTROL OF YOUR HOME

at your fingertips



A single app to control your entire home!

Connecting to the AirHome app gives you optimal control of your HVAC equipment. An all-in-one app managing your air conditioning, heating, ventilation, domestic hot water and connected objects in the house, which makes your daily life easier (Plug&Play) while saving money.



CONTROL YOUR HOME

Program all the appliances in the house, set the ideal temperature at different times of day according to your routine, manage different scenarios – all through AirHome to ensure total comfort while saving energy.



CONTROL YOUR CONSUMPTION

Easily view the consumption of your devices according to your uses*.



CONNECTIVITY

Connect all your devices in a few clicks: your heat pump and other Airwell products, your compatible photovoltaic panels and other connected household equipment*.



SOLAR ENERGY PRODUCTION

View a snapshot of your solar electricity production at any time, as well as the history.



ENERGY SAVING

Make big energy savings without having to think about it, our app's algorithm automatically optimizes the consumption of your devices by alternating solar and grid production*.

* Under development for 2023.



Download the app



Smart

AIRCONNECT PRO

For air/water heat pump

Maintenance available with AirConnect Pro on our WELLEA range from Q2 2023.



CONTROLLING & MONITORING, PREDICTIVE MAINTENANCE AND ENERGY METERING OF HEAT PUMP INSTALLATIONS

accessible on smartphone, tablet* or computer



www.airconnectpro.com



Download on the App Store



GET IT ON Google play



Simple data collection with the AirConnect Pro HP cloud box

You can view all the data and perform commissioning remotely!

* For the Control App.

THERMAL COMFORT OPTIMAL

Entrust your thermal comfort to AirConnect Pro, to free you from technical constraints and operating hazards.

PREDICTIVE MAINTENANCE

Go from reactivity to proactivity! Easily create your predictive rules to prevent any problem or untimely shutdown of your systems.

TECHNICAL DIAGNOSTICS

Carry out your technical diagnostics remotely in no time and offer a technical service of unparalleled quality and speed while optimizing the work of on-site technicians.

REMOTE CONTROL

Manage modes, set points, programming schedules or limitations of each of your sites remotely.

ALERT MANAGEMENT

Be alerted to the slightest drift! Alerts and anomalies can be sent directly to your technicians according to their level of technical expertise or their geographical proximity.

HISTORY MANAGEMENT

Access the complete operating history (fluidic and electrical) of each indoor and outdoor unit since the day it was commissioned. Make comparisons between periods or between sites.

VISUALIZATION OF YOUR HEAT PUMPS FLEET

Visualize the parameters of all your heat pumps spread over a city, a region, a country or the whole world.

AIRCONNECT PRO IS A COMPLETE SOLUTION

- ▶ **CONTROL APP:** control of the indoor units
- ▶ **SERVICE APP:** diagnosis and preventive maintenance

CONTROL APP (heat pump control)	<p>Unique solution for remote control of heat pumps</p> <ul style="list-style-type: none"> • Management of modes, setpoint temperatures, fan speed • “Weekly schedule” programming without rule limitation • Creation of control zones for energy savings
SERVICE APP (diagnosis and preventive maintenance)	<p>The ONLY preventive remote maintenance solution on the market: Prevent a breakdown before it happens!</p> <ul style="list-style-type: none"> • Remote display of all heat pumps installation parameters and one-click diagnosis • Recording of all data allowing a complete history of operation • Management and continued of alerts to designated technicians

SERVICE REFERENCES

	5 YEARS PACK	FROM YEAR 6
	AIRCONNECT PRO HP Box with 5 years licence	Tacit renewal of the license for 5 years
AIRCONNECT PRO HP BOX	SO3399999	
HEAT PUMP SERVICE APP LICENCE PER YEAR		SO3311111



SOLAR

Range

MODEL

PICTURE

p.28

SOLAR PANELS



ELECTRICAL BOXES



MICRO-INVERTERS AND
WIRING ACCESSORIES



PITCHED ROOF KITS



PHOTOVOLTAIC PACK



EXAMPLE OF RE KIT

Close-up of photovoltaic installation

Airwell promotes **solar energy**, and offers a wide solar range to cultivate comfort in every home, while optimising its energy consumption.

Module PVMX-500M-FB



Communication gateway ECU-R



For further details, please refer to the AirSolar solutions solar guide, available from our document library.



VS+ cover
41x35mm

Module
PVMX-375M-FB

Micro-inverter
DS3-L

VS+ mounting profile
41x35x2250 mm

VS+ connector rail
41x35mm

Y3 AC bus (2m)

RS1 universal
flange

AC bus end cap

Roof
hook RH1
(without
screws)

Lentic.
wood screw
6x80 SIT30

Electrical
box

Smart electric
meter



AIR/WATER HEAT PUMP

Range

	MODEL	REFERENCE	REFRI- GERANT TYPE	Preferred application	Mode	Domestic hot water
p.32	 <p>SPLIT HEAT PUMP WITH DHW TANK</p>	WELLEA WT	R32	New-build	Heating and cooling	Built-in
p.34	 <p>SPLIT HEAT PUMP</p>	WELLEA Split	R32	New-build	Heating and cooling	Optionnal
p.36	 <p>MONOBLOCK HEAT PUMP</p>	WELLEA Monoblock	R32	Renovation	Heating and cooling	Optionnal
p.38	 <p>MONOBLOCK HEAT PUMP</p>	WELLEA Monoblock DF	R32	Renovation	Heating and cooling	Optionnal



Triple-service
heat pump



HYBRID
HOUSE by Airwell



+ PRODUCT

- Stainless steel hot water tank included (190L or 240L)
- Refrigerant connections, no need for antifreeze protection
- Wide power range, and water output up to 60°C: ideal for new and renovated installation
- 3 kW electric back-up included

FEATURES

 PROGRAMMABLE TIMER	 WEEKLY TIMER	 REMOTE CONTROL LOCK	 UNIT ON/OFF OUTPUT
 HEATING MODE OPERATIONAL DOWN TO -25°C OUTDOORS	 HIGH TEMPERATURE UP TO 60°C	 DOMESTIC HOT WATER	 FLOOR HEATING
 HIGH TEMPERATURE RADIATOR	 LOW TEMPERATURE RADIATOR	 BOILER REPLACEMENT	 BOILER BACK-UP
 WATER PROGRAMS			

WELLEA WT

Split heat pump
with DHW tank included

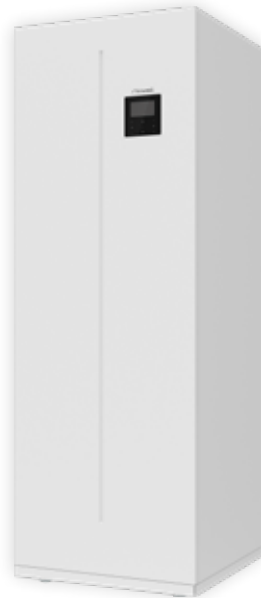

WELLEA WT
with DHW tank
included



WELLEA
ODU 4-6 kW



WELLEA
ODU 8-16 kW



+ “SUSTAINABLE DEVELOPMENT”

- > Stainless steel tank: reinforced durability.
- > Energy saving thanks to energy class A+++.
- > Cut your bills: COP up to 5.20.

+ “USER”

- > Space saving, a product able to manage all your needs.
- > Saves on heating elements thanks to the 60°C water temperature.
- > Heat pump remote-controlled thanks to AirHome connectivity (as standard).

+ “INSTALLER”

- > Customisable water program.
- > **ZERO** concept option: 2-area control, dual-purpose control, Smart Grid contact, and more as standard.
- > Un produit triple service: Heating / Cooling / Domestic hot water.

+ “TECHNOLOGY”

- > Ultra-quiet model: 30 dB(A) at 5 m⁽¹⁾.
- > Works down to an outdoor of -25°C.
- > Certifie HP Keymark, performances garanties.

See technical draws page 142

(1) Acoustic pressure of 4 kW model, free field directivity 1.

TECHNICAL DATA

OUTDOOR UNIT			AW-YHPSA04-H91	AW-YHPSA06-H91	AW-YHPSA08-H91	AW-YHPSA10-H91	AW-YHPSA12-H91	AW-YHPSA14-H91	AW-YHPSA16-H91	AW-YHPSA12-H93	AW-YHPSA14-H93	AW-YHPSA16-H93
Part number			7HP061065	7HP061066	7HP061067	7HP061068	7HP061069	7HP061070	7HP061071	7HP061072	7HP061073	7HP061074
Phase			Single-phase	Single-phase	Single-phase	Single-phase	Single-phase			Three-phase		
HEATING MODE												
Air +7°C Water 30/35°C	Heating capacity	kW	4.25	6.20	8.30	10.00	12.10	14.50	16.00	12.10	14.50	16.00
	Power input	kW	0.82	1.24	1.60	2.00	2.44	3.09	3.56	2.44	3.09	3.56
	COP		5.20	5.00	5.20	5.00	4.95	4.70	4.50	4.95	4.70	4.50
Air -7°C Water 30/35°C	Heating capacity	kW	4.80	6.10	7.10	8.25	10.00	12.00	13.30	10.00	12.00	13.30
	Power input	kW	1.52	2.00	2.18	2.62	3.33	4.29	4.93	3.33	4.29	4.93
	COP		3.15	3.05	3.25	3.15	3.00	2.80	2.70	3.00	2.80	2.70
Air +7°C Water 47/55°C	Heating capacity	kW	4.40	6.00	7.50	9.50	12.00	13.80	16.00	12.00	13.80	16.00
	Power input	kW	1.49	2.00	2.36	3.06	3.87	4.60	5.52	3.87	4.60	5.52
	COP		2.95	3.00	3.18	3.10	3.10	3.00	2.90	3.10	3.00	2.90
Air -7°C Water 47/55°C	Heating capacity	kW	4.00	5.15	6.15	7.05	10.60	11.30	12.60	10.60	11.30	12.60
	Power input	kW	2.05	2.58	3.00	3.53	5.25	5.46	6.29	5.25	5.46	6.29
	COP		1.95	2.00	2.05	1.97	2.02	2.01	2.00	2.02	2.01	2.00
COOLING MODE												
Air 35°C Water 12/7°C	Cooling capacity	kW	4.70	7.00	7.40	8.20	11.60	12.70	14.00	11.60	12.70	14.00
	Power input	kW	1.36	2.33	2.19	2.48	4.22	4.98	5.71	4.22	4.98	5.71
	EER		3.45	3.00	3.38	3.30	2.75	2.55	2.45	2.75	2.55	2.45
Air 35°C Water 23/18°C	Cooling capacity	kW	4.50	6.55	8.40	10.00	12.00	13.50	14.90	12.00	13.50	14.90
	Power input	kW	0.81	1.34	1.66	2.08	3.00	3.75	4.38	3.00	3.75	4.38
	EER		5.55	4.90	5.05	4.80	4.00	3.60	3.40	4.00	3.60	3.40
PERFORMANCE												
Energy label (Average climate)	Water outlet to 35°C		A+++				A+++					
	Water outlet to 55°C		A++				A++					
Seasonal efficiency (Average climate)	Water outlet to 35°C	%	191	195	205	205	189	186	182	189	186	182
	Water outlet to 55°C	%	130	138	132	137	135	136	133	135	136	133
SCOP (Average climate)	Water outlet to 35°C		4.85	4.95	5.21	5.19	4.81	4.72	4.62	4.81	4.72	4.62
	Water outlet to 55°C		3.31	3.52	3.36	3.49	3.45	3.47	3.41	3.45	3.47	3.41
Sound level		dB(A)	56	58	59	60	64	65	68	64	65	68
Sound pressure level (1m)		dB(A)	44	45	46	49	50	51	55	50	51	55
OPERATING LIMITS												
Outdoor air temperature	Cooling	°C	-5/43				-5/43					
	Heating	°C	-25/35				-25/35					
	Domestic hot water	°C	-25/43				-25/43					
POWER SUPPLY												
Phase/Voltage/Frequency			1P/220-240V/50Hz				1P/220-240V/50Hz			3P/380-415V/50Hz		
Power cable section	mm²		3G2.5			3G2.5	3G4	3G6	3G6	5G2.5	5G2.5	5G2.5
Fuse rating am	A		16			20	25	32	32	16	16	16
Electrical connections in/out (shielded)	mm²		2x1.5			2x1.5	2x1.5	2x1.5	2x1.5	2x1.5	2x1.5	2x1.5
INSTALLATION AND OTHERS												
Airflow	m³/h		2770			4030	4060		4650	4060		4650
Refrigerant/GWP			R32/675				R32/675					
Charge (15m)	kg		1.50			1.65	1.84					
Additional charge	g/m		20			38	38					
Outline dimensions (WxHxD)	mm		1008x712x426				1118x865x523			1118x865x523		
Package dimensions (WxHxD)	mm		1065x800x485				1180x890x560			1180x890x560		
Net weight/Gross weight	kg		58/64			77/88	96/110			112/125		
Pipe diameter (liquid - gas)	inches		1/4" - 5/8"			3/8" - 5/8"	3/8" - 5/8"			3/8" - 5/8"		

INDOOR UNIT		ODMA-100T-09M22-19				ODMA-100T-09M22-25				ODMA-160T-09M22-25					
Part number		7SPI30001				7SPI30002				7SPI30003					
COMPATIBLE OUTDOOR UNIT		AW-YHPSA04-H91	AW-YHPSA06-H91	AW-YHPSA08-H91	AW-YHPSA10-H91	AW-YHPSA04-H91	AW-YHPSA06-H91	AW-YHPSA08-H91	AW-YHPSA10-H91	AW-YHPSA12-H91	AW-YHPSA14-H91	AW-YHPSA16-H91	AW-YHPSA12-H93	AW-YHPSA14-H93	AW-YHPSA16-H93
Phase		Single-phase				Single-phase				Single-phase					
TANK															
Volume	l	190				240				240					
Electrical resistor	kW	3				3				3					
PERFORMANCE EN16147 (AVERAGE CLIMATE)															
DHW profile		L				XL				XL					
DHW energy label (average climate)		A+				A+				A+					
DHW seasonal efficiency (average climate)	%	127				136				123					
DHW COP		3.10				3.34				3.00					
Sound level	dB(A)	42				42				43					
Sound pressure level (1m)	dB(A)	30				30				32					
POWER SUPPLY															
Phase/Voltage/Frequency		1P/220-240V/50Hz				1P/220-240V/50Hz				1P/220-240V/50Hz					
Electrical resistor	kW	3.00				3.00				3.00					
Power cable section (electric back-up integrated)	mm²	3G2.5				3G2.5				3G2.5					
Fuse rating am (electric back-up integrated)	A	16				16				16					
INSTALLATION AND OTHERS															
Water pipe diameter	inches	R1				R1				R1					
DHW pipe diameter	inches	R3/4				R3/4				R3/4					
Outline dimensions (WxHxD)	mm	600x1683x600				600x1943x600				600x1943x600					
Package dimensions (WxHxD)	mm	653x1900x653				653x2160x653				653x2160x653					
Net weight/Gross weight	kg	140/161				157/178				159/180					



Reversible
heat pump



HYBRID
HOUSE by Airwell



+ PRODUCT

- Refrigerant connections, no need for antifreeze protection
- Wide power range, and water output up to 60°C: ideal for new and renovated installation
- 3 kW or 9 kW electric back-up included⁽²⁾

FEATURES

 PROGRAMMABLE TIMER	 WEEKLY TIMER	 REMOTE CONTROL LOCK	 UNIT ON/OFF OUTPUT
 HEATING MODE OPERATIONAL DOWN TO -25°C OUTDOORS	 HIGH TEMPERATURE UP TO 60°C	 FLOOR HEATING	 HIGH-TEMPERATURE RADIATOR
 LOW-TEMPERATURE RADIATOR	 BOILER REPLACEMENT	 BOILER BACK-UP	 WATER PROGRAMS

WELLEA SPLIT

Split heat pump



WELLEA Split
indoor unit



WELLEA
ODU 4-6 kW



WELLEA
ODU 8-16 kW



+ “SUSTAINABLE DEVELOPMENT”

- > Energy saving thanks to energy class A+++.
- > Cut your bills: COP up to 5.20.

+ “USER”

- > Ideal for replacing a gas or fuel oil boiler.
- > Saves on heating elements thanks to the 60°C water temperature.
- > Heat pump remote-controlled thanks to AirHome connectivity (as standard).

+ “INSTALLER”

- > Cascade management up to 6 units.
- > Customisable water program.
- > **ZERO** concept option: 2-area control, dual-purpose control, Smart Grid contact, and more as standard.
- > A triple-service product: Heating / Cooling / Domestic hot water.

+ “TECHNOLOGY”

- > Ultra-quiet model: 30 dB(A) at 5 m⁽¹⁾.
- > Works down to an outdoor of -25°C.
- > HP Keymark certified, guaranteed performance.

See technical draws page 142

(1) Acoustic pressure of 4 kW model, free field directivity 1.
(2) Depending on model.

TECHNICAL DATA

Wellea Split

Air/Water
Heat pump

OUTDOOR UNIT	AW-YHPSA04-H91	AW-YHPSA06-H91	AW-YHPSA08-H91	AW-YHPSA10-H91	AW-YHPSA12-H91	AW-YHPSA14-H91	AW-YHPSA16-H91	AW-YHPSA12-H93	AW-YHPSA14-H93	AW-YHPSA16-H93
Part number	7HP061065	7HP061066	7HP061067	7HP061068	7HP061069	7HP061070	7HP061071	7HP061072	7HP061073	7HP061074
Phase	Single-phase			Single-phase			Three-phase			

HEATING MODE

Air +7°C Water 30/35°C	Heating capacity	kW	4.25	6.20	8.30	10.00	12.10	14.50	16.00	12.10	14.50	16.00
	Power input	kW	0.82	1.24	1.60	2.00	2.44	3.09	3.56	2.44	3.09	3.56
	COP		5.20	5.00	5.20	5.00	4.95	4.70	4.50	4.95	4.70	4.50
Air -7°C Water 30/35°C	Heating capacity	kW	4.80	6.10	7.10	8.25	10.00	12.00	13.30	10.00	12.00	13.30
	Power input	kW	1.52	2.00	2.18	2.62	3.33	4.29	4.93	3.33	4.29	4.93
	COP		3.15	3.05	3.25	3.15	3.00	2.80	2.70	3.00	2.80	2.70
Air +7°C Water 47/55°C	Heating capacity	kW	4.40	6.00	7.50	9.50	12.00	13.80	16.00	12.00	13.80	16.00
	Power input	kW	1.49	2.00	2.36	3.06	3.87	4.60	5.52	3.87	4.60	5.52
	COP		2.95	3.00	3.18	3.10	3.10	3.00	2.90	3.10	3.00	2.90
Air -7°C Water 47/55°C	Heating capacity	kW	4.00	5.15	6.15	7.05	10.60	11.30	12.60	10.60	11.30	12.60
	Power input	kW	2.05	2.58	3.00	3.53	5.25	5.46	6.29	5.25	5.46	6.29
	COP		1.95	2.00	2.05	1.97	2.02	2.01	2.00	2.02	2.01	2.00

COOLING MODE

Air 35°C Water 12/7°C	Cooling capacity	kW	4.70	7.00	7.40	8.20	11.60	12.70	14.00	11.60	12.70	14.00
	Power input	kW	1.36	2.33	2.19	2.48	4.22	4.98	5.71	4.22	4.98	5.71
	EER		3.45	3.00	3.38	3.30	2.75	2.55	2.45	2.75	2.55	2.45
Air 35°C Water 23/18°C	Cooling capacity	kW	4.50	6.55	8.40	10.00	12.00	13.50	14.90	12.00	13.50	14.90
	Power input	kW	0.81	1.34	1.66	2.08	3.00	3.75	4.38	3.00	3.75	4.38
	EER		5.55	4.90	5.05	4.80	4.00	3.60	3.40	4.00	3.60	3.40

PERFORMANCE

Energy label (average climate)	Water outlet to 35°C		A+++				A+++					
	Water outlet to 55°C		A++				A++					
Seasonal efficiency (average climate)	Water outlet to 35°C	%	191	195	205	205	189	186	182	189	186	182
	Water outlet to 55°C	%	130	138	132	137	135	136	133	135	136	133
SCOP (average climate)	Water outlet to 35°C		4.85	4.95	5.21	5.19	4.81	4.72	4.62	4.81	4.72	4.62
	Water outlet to 55°C		3.31	3.52	3.36	3.49	3.45	3.47	3.41	3.45	3.47	3.41
Sound level		dB(A)	56	58	59	60	64	65	68	64	65	68
Sound pressure level at 1m		dB(A)	44	45	46	49	50	51	55	50	51	55

OPERATING LIMITS

Outdoor air temperature	Cooling	°C	-5/43				-5/43				
	Heating	°C	-25/35				-25/35				
	DHW	°C	-25/43				-25/43				

POWER SUPPLY

Phase/Voltage/Frequency		1P/220-240V/50Hz			1P/220-240V/50Hz			3P/380-415V/50Hz		
Power cable section	mm ²	3G2.5	3G2.5	3G4	3G6	3G6	5G2.5	5G2.5	5G2.5	
Fuse rating am	A	16	20	25	32	32	16	16	16	
Electrical connections in/out (shielded)	mm ²	2x1.5	2x1.5	2x1.5	2x1.5	2x1.5	2x1.5	2x1.5	2x1.5	

INSTALLATION AND OTHERS

Airflow	m ³ /h	2770	4030	4060	4650	4060	4650
Refrigerant/GWP		R32/675			R32/675		
Charge (15m)	kg	1.50	1.65	1.84			
Additional charge	g/m	20	38	38			
Outline dimensions (WxHxD)	mm	1008x712x426	1118x865x523	1118x865x523			
Package dimensions (WxHxD)	mm	1065x800x485	1180x890x560	1180x890x560			
Net weight/Gross weight	kg	58/64	77/88	96/110		112/125	
Pipe diameter (liquid - gas)	inches	1/4" - 5/8"	3/8" - 5/8"	3/8" - 5/8"			

INDOOR UNIT	AW-WHPSA0406-N91	AW-WHPSA0810-N91	AW-WHPSA1216-N91	AW-WHPSA1216-N93
Part number	7HP010015	7HP010016	7HP010017	7HP010018
Phase	Single-phase	Single-phase	Single-phase	Three-phase

PERFORMANCE

Sound level	dB(A)	38	42	43	43
Sound pressure level (1m)		28	30	32	32

POWER SUPPLY

Phase/Voltage/Frequency		1P/220-240V/50Hz		1P/220-240V/50Hz		3P/380-415V/50Hz	
Electric backup heater	kW	3	3	3	3/6/9		
Power cable section (electric back-up integrated)	mm ²	3G2.5	3G2.5	3G2.5	5G2.5		
Fuse rating am (electric back-up integrated)	A	16	16	16	16		

INSTALLATION AND OTHERS

Water pipe diameter	inches	R1		R1	
Outline dimensions (WxHxD)	mm	420x790x270		420x790x270	
Package dimensions (WxHxD)	mm	525x1050x360		525x1050x360	
Net weight/Gross weight	kg	43/49		45/51	



Reversible
heat pump



HYBRID
HOUSE by Airwell



+ PRODUCT

- RCW30 remote control included
- Wide power range, and water output up to 60°C: ideal for new and renovated installation
- 3 kW or 9 kW electric back-up included⁽²⁾

FEATURES



WEEKLY TIMER



COOLING MODE
OPERATIONAL UP TO
43°C OUTDOORS



HEATING MODE
OPERATIONAL DOWN
TO -25°C OUTDOORS



HIGH TEMPERATURE
UP TO 60°C



FLOOR HEATING



HIGH-TEMPERATURE
RADIATOR



LOW-TEMPERATURE
RADIATOR



BOILER BACK-UP



SUPER
QUIET



WI-FI



WATER
PROGRAMS

WELLEA MONOBLOCK

Monoblock heat pump



RCW30
included



4-6 kW



8-16 kW



+ “SUSTAINABLE DEVELOPMENT”

- > Energy saving thanks to energy class A+++.
- > Cut your bills: COP up to 5.10.

+ “USER”

- > Ideal for replacing a gas or fuel oil boiler.
- > Saves on heating elements thanks to the 60°C water temperature.
- > Heat pump remote-controlled thanks to AirHome connectivity (as standard).

+ “INSTALLER”

- > Cascade management up to 6 units.
- > Customisable water program.
- > **ZERO** concept option: 2-area control, dual-purpose control, Smart Grid contact, and more as standard.
- > A triple-service product: Heating / Cooling / Domestic hot water.

+ “TECHNOLOGY”

- > Ultra-quiet model: 30 dB(A) at 5 m⁽¹⁾.
- > Works down to an outdoor of -25°C.
- > HP Keymark certified, guaranteed performance.

See technical draws page 143

(1) Acoustic pressure of 4 kW model, free field directivity 1.

(2) Depending on model.

TECHNICAL DATA

OUTDOOR UNIT	AW-WHPMA 04-H91	AW-WHPMA 06-H91	AW-WHPMA 08-H91	AW-WHPMA 10-H91	AW-WHPMA 12-H91	AW-WHPMA 14-H91	AW-WHPMA 16-H91	AW-WHPMA 12-H93	AW-WHPMA 14-H93	AW-WHPMA 16-H93	
Part number	7HP061075	7HP061076	7HP061077	7HP061078	7HP061079	7HP061080	7HP061081	7HP061082	7HP061083	7HP061084	
Phase	Single-phase				Single-phase			Three-phase			

HEATING MODE

Air +7°C Water 30/35°C	Heating capacity	kW	4.20	6.35	8.40	10.00	12.10	14.50	15.90	12.10	14.50	15.90
	Power input	kW	0.82	1.28	1.63	2.02	2.44	3.15	3.53	2.44	3.15	3.53
	COP		5.10	4.95	5.15	4.95	4.95	4.60	4.50	4.95	4.60	4.50
Air -7°C Water 30/35°C	Heating capacity	kW	4.70	6.00	7.00	8.00	10.00	12.00	13.10	10.00	12.00	13.10
	Power input	kW	1.52	2.00	2.19	2.62	3.33	4.21	4.85	3.33	4.21	4.85
	COP		3.10	3.00	3.20	3.05	3.00	2.85	2.70	3.00	2.85	2.70
Air +7°C Water 47/55°C	Heating capacity	kW	4.40	6.00	7.50	9.50	12.00	13.80	16.00	12.00	13.80	16.00
	Power input	kW	1.49	2.00	2.36	3.06	3.87	4.60	5.52	3.87	4.60	5.52
	COP		2.95	3.00	3.18	3.10	3.10	3.00	2.90	3.10	3.00	2.90
Air -7°C Water 47/55°C	Heating capacity	kW	4.00	5.15	6.15	7.05	10.60	11.30	12.60	10.60	11.30	12.60
	Power input	kW	2.05	2.58	3.00	3.53	5.25	5.46	6.29	5.25	5.46	6.29
	COP		1.95	2.00	2.05	1.97	2.02	2.01	2.00	2.02	2.01	2.00

COOLING MODE

Air 35°C Water 12/7°C	Cooling capacity	kW	4.70	7.00	7.45	8.20	11.50	12.40	14.00	11.50	12.40	14.00
	Power input	kW	1.36	2.33	2.22	2.52	4.18	4.96	5.60	4.18	4.96	5.60
	EER		3.45	3.00	3.35	3.25	2.75	2.50	2.50	2.75	2.50	2.50
Air 35°C Water 23/18°C	Cooling capacity	kW	4.50	6.50	8.30	9.90	12.00	13.50	14.90	12.00	13.50	14.90
	Power input	kW	0.82	1.35	1.64	2.18	3.04	3.75	4.38	3.04	3.75	4.38
	EER		5.50	4.80	5.05	4.55	3.95	3.60	3.40	3.95	3.60	3.40

PERFORMANCE

Energy label (average climate)	Water outlet to 35°C		A+++				A+++					
	Water outlet to 55°C		A++				A++					
Seasonal efficiency (average climate)	Water outlet to 35°C	%	191	195	205	205	189	186	182	189	186	182
	Water outlet to 55°C	%	130	138	132	137	135	136	133	135	136	133
SCOP (average climate)	Water outlet to 35°C		4.85	4.95	5.21	5.19	4.81	4.72	4.62	4.81	4.72	4.62
	Water outlet to 55°C		3.31	3.52	3.36	3.49	3.45	3.47	3.41	3.45	3.47	3.41
Sound level		dB(A)	55	58	59	60	65	65	68	65	65	68
Sound pressure level at 1m		dB(A)	45	48	49	51	53	54	58	54	54	58

OPERATING LIMITS

Outdoor air temperature	Cooling	°C	-5/43				-5/43					
	Heating	°C	-25/35				-25/35					
	DHW	°C	-25/43				-25/43					

POWER SUPPLY

Phase/Voltage/Frequency		1P/220-240V/50Hz				1P/220-240V/50Hz			3P/380-415V/50Hz			
Electric backup heater	kW	0		3		3			3/6/9			
Power cable section (electric back-up integrated)	mm ²	3G2.5	3G2.5	3G6	3G6	3G10	3G10	3G10	5G4	5G4	5G4	
Fuse rating am (electric back-up integrated)	A	16	16	32	32	40	40	40	25	25	25	

INSTALLATION AND OTHERS

Airflow	m ³ /h	2770		4030		4060		4650		4060		4650	
Refrigerant/GWP		R32/675						R32/675					
Charge	kg	1.40				1.40				1.75			
Outline dimensions (WxHxD)	mm	1295x792x429				1385x945x526				1385x945x526			
Package dimensions (WxHxD)	mm	1375x965x475				1465x1120x560				1465x1120x560			
Net weight/Gross weight	kg	98/121		121/148		144/170				160/188			
Water inlet/outlet diameter	inches	R 1"		R 1"1/4		R 1"1/4				R 1"1/4			



Reversible
heat pump



HYBRID
HOUSE by Airwell



+ PRODUCT

- RCW30 remote control included
- Wide power range, and water output up to 60°C: ideal for new installation
- Cascade management up to 6 units.

FEATURES



WEEKLY TIMER



COOLING MODE
OPERATIONAL UP TO
46°C OUTDOORS



HEATING MODE
OPERATIONAL DOWN
TO -25°C OUTDOORS



HIGH TEMPERATURE
UP TO 60°C



FLOOR HEATING



HIGH TEMPERATURE
RADIATOR



LOW TEMPERATURE
RADIATOR



BOILER BACK-UP



SUPER QUIET



WI-FI



WATER PROGRAMS

WELLEA MONOBLOCK DF

Monoblock heat pump



18-30 kW



RCW30
included



+ "SUSTAINABLE DEVELOPMENT"

- > Energy saving thanks to energy class A+++.
- > Cut your bills: COP up to 4.63.

+ "USER"

- > Ideal for replacing a gas or fuel oil boiler.
- > Saves on heating elements thanks to the 60°C water temperature.
- > Heat pump remote-controlled thanks to AirHome connectivity (as standard).

+ "INSTALLER"

- > Customisable water program.
- > **ZERO** concept option: 2-area control, dual-purpose control, Smart Grid contact, and more as standard.
- > A triple-service product: Heating / Cooling / Domestic hot water.

+ "TECHNOLOGY"

- > Works down to an outdoor of -25°C.
- > HP Keymark certified, guaranteed performance.

See technical draws page 143

(1) Acoustic pressure of 4 kW model, free field directivity 1.

TECHNICAL DATA

OUTDOOR UNIT			AW-WHPMA18-H93	AW-WHPMA22-H93	AW-WHPMA26-H93	AW-WHPMA30-H93
Part number			7HP061085	7HP061086	7HP061087	7HP061088
Phase			Three-phase			
HEATING MODE						
Air +7°C Water 30/35°C	Heating capacity	kW	18.30	22.30	26.30	29.93
	Power input	kW	3.96	5.13	6.50	8.02
	COP		4.63	4.35	4.05	3.73
Air -7°C Water 30/35°C	Heating capacity	kW	18.00	21.00	22.00	23.00
	Power input	kW	6.67	8.08	8.80	9.39
	COP		2.70	2.60	2.50	2.45
Air +7°C Water 47/55°C	Heating capacity	kW	18.10	22.10	26.06	29.68
	Power input	kW	6.63	8.33	10.72	12.97
	COP		2.73	2.65	2.43	2.29
Air -7°C Water 47/55°C	Heating capacity	kW	10.70	13.50	16.70	22.30
	Power input	kW	8.78	10.40	12.20	14.10
	COP		1.22	1.30	1.37	1.58
COOLING MODE						
Air 35°C Water 12/7°C	Cooling capacity	kW	17.00	21.00	26.00	29.50
	Power input	kW	5.57	7.12	9.63	11.57
	EER		3.05	2.95	2.70	2.55
Air 35°C Water 23/18°C	Cooling capacity	kW	18.50	23.00	27.00	31.00
	Power input	kW	3.90	5.00	6.28	7.75
	EER		4.75	4.60	4.30	4.00
PERFORMANCE						
Energy label (average climate)	Water outlet to 35°C		A+++			A++
	Water outlet to 55°C		A++			A+
Seasonal efficiency (average climate)	Water outlet to 35°C	%	181	178	177	165
	Water outlet to 55°C	%	125	126	123	123
SCOP (average climate)	Water outlet to 35°C		4.60	4.53	4.50	4.19
	Water outlet to 55°C		3.21	3.22	3.14	3.14
Sound level		dB(A)	71	73	75	77
Sound pressure level at 1m		dB(A)	58	60	62	64
OPERATING LIMITS						
Outdoor air temperature	Cooling	°C	-5/46			
	Heating	°C	-25/35			
	DHW	°C	-25/43			
POWER SUPPLY						
Phase/Voltage/Frequency		3P/380-415V/50Hz				
Power cable section	mm ²	5G4	5G4	5G6	5G6	
Fuse rating am	A	25	25	32	32	
INSTALLATION AND OTHERS						
Airflow	m ³ /h	10650			11200	
Refrigerant/GWP		R32/675				
Charge	kg	5				
Outline dimensions (WxHxD)	mm	1129x1558x440				
Package dimensions (WxHxD)	mm	1220x1735x565				
Net weight/Gross weight	kg	177/206				
Water inlet/outlet diameter	inches	R1-1/4"				



Wellea Monoblock DF

Air/Water
Heat pump



DOMESTIC HOT WATER PRODUCTION

Range

	MODEL	REFERENCE	REFRI-GERANT TYPE	DHW profil	Characteristic
p.42	 SPLIT THERMODYNAMIC WATER HEATER	TFHX Eleo	R134A	L	Split
p.44	 MONOBLOCK THERMODYNAMIC WATER HEATER	TFHW Eleo	R134A	M & XL	Monoblock
p.46	 SOLAR THERMODYNAMIC WATER HEATER	TFHZ Eleo	R134A	M & L	Solar
p.48	Domestic hot water production kits				
p.50	Heating and DHW accessories				



Domestic hot water production



HYBRID
HOUSE by Airwell



TFHX ELEO

Split thermodynamic water heater

Stainless steel tank

+ PRODUCT

- High performance
- Small footprint
- Anti-legionella function

FEATURES



DOMESTIC HOT WATER



TFHX



YFHX

+ “SUSTAINABLE DEVELOPMENT”

- > Energy savings thanks to the A+ energy label.
- > High-performance product.
- > Electrical consumption reduced by up to 75%.
- > Holiday mode: the water heater switches off while you are away, and switches back on the day before you come back.

+ “USER”

- > Perfect to replace an electric tank.
- > “Peak/Off peak” operation.
- > Available water volume displayed on the control screen.
- > A variety of operating modes (ECO / BOOST / AUTO) for ease of use.

+ “INSTALLER”

- > No ventilation duct installation: split model.
- > Easy to install, thanks to its compact footprint.
- > Easy handling, thanks to its low weight < 80 kg.

+ “TECHNOLOGY”

- > No risk of contamination following a refrigerant leak, thanks to the external exchanger.
- > Hard water protection: stainless steel tank + magnesium anode.

See technical draws page 144

TECHNICAL DATA

TFHX E160

Air/Water
DHW

INDOOR UNIT		TFHX-200H-03M25	
Part number		7SP170001	
Phase		Single-phase	
Volume	l	200	
AIR +7°C WATER 10/55°C			
Heating capacity	kW	2.13	
Total power input	kW	0.69	
COP		3.10	
AIR +15°C WATER 10/55°C			
Heating capacity	kW	2.75	
Total power input	kW	0.74	
COP		3.70	
PERFORMANCE EN16147 (AVERAGE CLIMATE)			
DHW profile		L	
Energy label		A+	
Energetic efficiency	%	119	
COP		2.66	
Annual consumption	kWh	858	
Heat up time	h:mm	7:50	
Standby power input	W	87.0	
Reference hot water temperature	°C	51.0	
Volume of mixed water at 40°C	l	249	
PERFORMANCE (WARMER CLIMATE)			
Energetic efficiency	%	136	
Annual consumption	kWh	748	
PERFORMANCE (COLDER CLIMATE)			
Energetic efficiency	%	93	
Annual consumption	kWh	1089	
OPERATING LIMITS			
Outdoor air temperature	°C	-7 / 43	
Maximum water temperature	°C	70	
INDOOR UNIT			
Sound pressure level (1 m)	dB(A)	18	
Sound level	dB(A)	33	
Outline dimensions (HxØ)	mm	1580x470	
Package dimensions (WxHxD)	mm	595x1605x595	
Net weight/Gross weight	kg	51/54	
OUTDOOR UNIT		YFHX-028H-03M25	
Part number		7SP063214	
Sound pressure level (1 m)	dB(A)	51	
Sound level	dB(A)	65	
Outline dimensions (WxHxD)	mm	858x545x320	
Package dimensions (WxHxD)	mm	902x606x342	
Net weight/Gross weight	kg	29/33	
REFRIGERATION CIRCUIT			
Refrigerant/GWP		R134a/1430	
Charge	kg	1.30	
Suction pipe diameter	inches	3/8"	
Liquid pipe diameter	inches	1/4"	
POWER SUPPLY			
Phase/Voltage/Frequency		1P/220-240/50Hz	
Electric backup heater	kW	2	
Electrical connections in/out (provided)	mm ²	2x1,5 + 3x1,5	
Power cable section	mm ²	3G2,5	
Fuse rating am	A	16	
Net weight/Gross weight (top-up electric heater)	mm ²	3G1,5	

* Preliminary data.



Domestic hot water production



HYBRID
HOUSE by Airwell

TFHW ELEO

Monoblock thermodynamic water heater



Stainless steel tank

+ PRODUCT

- High performance
- Small footprint
- Anti-legionella function

FEATURES



DOMESTIC HOT WATER



TFHW 120L

TFHW 190 L / 260 L

+ “SUSTAINABLE DEVELOPMENT”

- > Energy savings thanks to the A+ energy label.
- > High-performance product.
- > Electrical consumption reduced by up to 75%.
- > Holiday mode: the water heater switches off while you are away, and switches back on the day before you come back.

+ “USER”

- > Perfect to replace an electric tank.
- > “Peak/Off peak” operation.
- > Available water volume displayed on the control screen.
- > A variety of operating modes (ECO / BOOST / AUTO) for ease of use.

+ “INSTALLER”

- > Easy to install, thanks to its compact footprint.
- > Easy handling, thanks to its low weight < 80 kg.

+ “TECHNOLOGY”

- > No risk of contamination following a refrigerant leak, thanks to the external exchanger.
- > Hard water protection: stainless steel tank + magnesium anode.

See technical draws page 145

TECHNICAL DATA

TFHW E1e0

Air/Water
DHW

MODEL		TFHW-120H-03M25	TFHW-190H-03M25	TFHW-260H-03M25
Part number		7MB170001	7MB170002	7MB170003
Phase		Single-phase	Single-phase	Single-phase
Volume	l	120	190	260
AIR +7°C WATER 10/55°C				
Heating capacity	kW	1.25	1.25	1.25
Total power input	kW	0.40	0.40	0.40
COP		3.15	3.15	3.15
AIR +15°C WATER 10/55°C				
Heating capacity	kW	1.50	1.50	1.50
Total power input	kW	0.41	0.41	0.41
COP		3.70	3.70	3.70
PERFORMANCE EN16147 (AVERAGE CLIMATE)				
DHW profile		M	M	XL
Energy label		A+	A++	A
Energetic efficiency	%	100	139	101
COP		2.55	3.21	2.41
Annual consumption	kWh	513	368	1653
Heat up time	h:mm	05:45	05:34	12:02
Standby power input	W	7	26	70
Reference hot water temperature	°C	52.3	52	59.5
Volume of mixed water at 40°C	l	192	277	378
PERFORMANCE (WARMER CLIMATE)				
Energetic efficiency	%	100	153	120
Annual consumption	kWh	513	335	1395
PERFORMANCE (COLDER CLIMATE)				
Energetic efficiency	%	100	104	80
Annual consumption	kWh	513	492	2009
SOUND LEVEL				
Sound pressure level (1m)	dB(A)	46	46	46
Sound level	dB(A)	59	59	59
OPERATING LIMITS				
Outdoor air temperature	°C	-7 / 43	-7 / 43	-7 / 43
Maximum water temperature	°C	70	70	70
REFRIGERATION CIRCUIT				
Refrigerant/GWP		R134a/1430	R134a/1430	R134a/1430
Charge	kg	0.85	0.85	0.85
POWER SUPPLY				
Phase/Voltage/Frequency		1P/220-240/50Hz	1P/220-240/50Hz	1P/220-240/50Hz
Electric backup heater	kW	2	2	2
Power cable section	mm ²	3G2.5	3G2.5	3G2.5
Fuse rating am	A	16	16	16
DIMENSIONS				
Outline dimensions (HxØ)		1310x568	1690x568	1950x568
Package dimensions (WxHxD)		690x1410x690	690x1750x690	690x2070x690
Net weight/Gross weight	kg	62/68	69/80	76/90



Domestic hot water production



HYBRID
HOUSE by Airwell

TFHZ ELEO

Solar thermodynamic water heater



Stainless steel tank

+ PRODUCT

- High performance
- Compatible with solar thermique
- Anti-legionella function

FEATURES



DOMESTIC HOT WATER

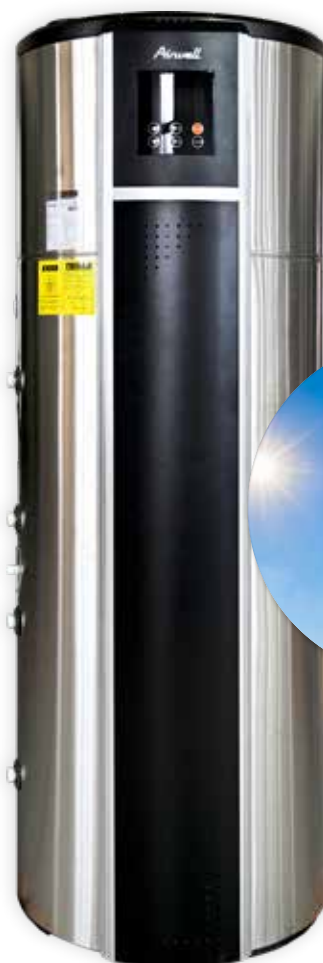

TFHZ

+ “SUSTAINABLE DEVELOPMENT”

- > Energy savings thanks to the A+ energy label.
- > High-performance product.
- > Electrical consumption reduced by up to 75%.
- > Holiday mode: the water heater switches off while you are away, and switches back on the day before you come back.

+ “USER”

- > Perfect to replace an electric tank.
- > “Peak/Off peak” operation.
- > Available water volume displayed on the control screen.
- > A variety of operating modes (ECO / BOOST / AUTO) for ease of use.

+ “INSTALLER”

- > Easy to install, thanks to its compact footprint.
- > Easy handling, thanks to its low weight < 80 kg.

+ “TECHNOLOGY”

- > No risk of contamination following a refrigerant leak, thanks to the external exchanger.
- > Hard water protection: stainless steel tank + magnesium anode.

See technical draws page 146

TECHNICAL DATA

MODEL		TFHZ-190S-03M25	TFHZ-300S-03M25
Part number		7MB170005	7MB170004
Phase		Single-phase	
Volume	l	190	300
AIR +7°C WATER 10/55°C			
Heating capacity	kW	1.90	
Total power input	kW	0.60	
COP		3.15	
AIR +15°C WATER 10/55°C			
Heating capacity	kW	2.45	
Total power input	kW	0.67	
COP		3.68	
PERFORMANCE EN16147 (AVERAGE CLIMATE)			
DHW profile		M	L
Energy label		A++	A++
Energetic efficiency	%	139	174
COP		3.21	4.12
Annual consumption	kWh	368	587
Heat up time	h:mm	5:34	7:49
Standby power input	W	26	27
Reference hot water temperature	°C	52	51.80
Volume of mixed water at 40°C	l	277	387
PERFORMANCE (WARMER CLIMATE)			
Energetic efficiency	%	153	191
Annual consumption	kWh	335	533
PERFORMANCE (COLDER CLIMATE)			
Energetic efficiency	%	104	133
Annual consumption	kWh	766	
SOUND LEVEL			
Sound pressure level (1m)	dB(A)	46	48
Sound level	dB(A)	59	59
OPERATING LIMITS			
Outdoor air temperature	°C	-7 / 43	
Maximum water temperature	°C	70	
SOLAR CIRCUIT			
Coil surface	m ²	1	
Fittings	inches	3/4"	
Material		Stainless steel	
REFRIGERATION CIRCUIT			
Refrigerant/GWP		R134a/1430	
Charge	kg	1.10	
POWER SUPPLY			
Phase/Voltage/Frequency		1P/220-240/50Hz	
Electric backup heater	kW	2	
Power cable section	mm ²	3G2.5	
Fuse rating am	A	16	
DIMENSIONS			
Outline dimensions (HxØ)		1485x646	1915x646
Package dimensions (WxHxD)		690x1680x690	710x2050x710
Net weight/Gross weight	kg	83/105	92/114

TFHZ E1e0

Air/Water
DHW

ACCESSORIES

for thermodynamic water heater

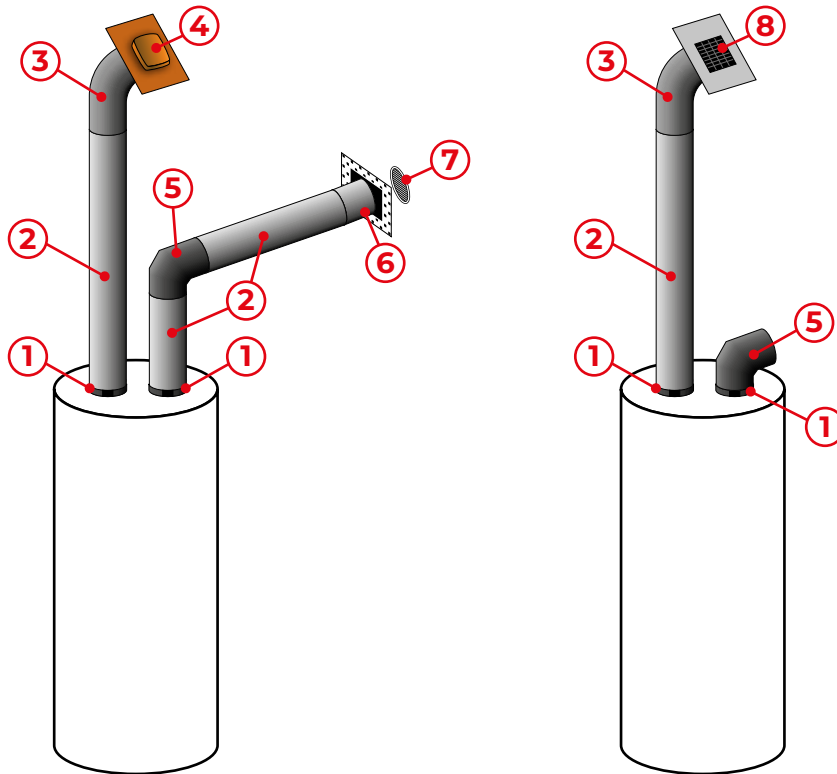

NUMBER	ACCESSORY	VISUAL
1	160 Clamp 160/160 Adapter Sealing foam	
2	160 duct	
3	160 flexible	
4	160 ochre roof terminal	
5	90° elbow	
6	Sealing sleeve	
7	White PVC grill	
8	160 slate roof terminal	

KIT 1 SEPERATE RETURN		PART NUMBER: 7ACVF0602
Designation	Quantity	Scheme number
160 clamp	1	1
160/160 adapter	1	
Sealing foam	1	
90° elbow	1	5

KIT 2 WALL OUTLET		PART NUMBER: 7ACVF0604
Designation	Quantity	Scheme number
160 clamp	1	1
160/160 adapter	1	
Sealing foam	1	
160 duct	1 ml	2
90° elbow	1	5
Sealing sleeve	1	6
160/160 connector	1	7
White PCV grill	1	











KIT 3 EXTENSION KIT		PART NUMBER: 7ACVF0603
Designation	Quantity	Scheme number
160/160 connector	1	2
160 duct	1 ml	

KIT 4 SLATE ROOF		PART NUMBER: 7ACVF0605
Designation	Quantity	Scheme number
160 clamp	1	1
160/160 adapter	1	
Sealing foam	1	
160 duct	5 ml	2
160 flexible	1	3
160 slate roof terminal	1	8

KIT 5 OCHRE ROOF		PART NUMBER: 7ACVF0606
Designation	Quantity	Scheme number
160 clamp	1	1
160/160 adapter	1	
Sealing foam	1	
160 duct	5 ml	2
160 flexible	1	3
160 ochre roof terminal	1	4

KIT 6 45° ELBOW		PART NUMBER: 7ACVF0607
Designation	Quantity	Scheme number
160/160 connector	2	
45° elbow	2	

ACCESSORIES

DESIGNATION	PART NUMBER	PICTURE	FUNCTIONS
Bizone Kit 2ZZT	7ACEL1882		<ul style="list-style-type: none"> This module makes it simple to manage 2 zones with 2 different temperatures (e.g.: floor heating & radiator). All the components are pre-wired, you just have to plug them in. 1 hydraulic module: <ul style="list-style-type: none"> - 2 condensate pumps - 1 regulator - 2 thermostats (radio) - 1 outdoor air temperature sensor (radio) - 1 antenna (for radio connection) Thermostat functions: <ul style="list-style-type: none"> - Temperature change (5 C to 37 C) - Mode switch (heating / air conditioning) - Weekly programming - Holiday mode
Hydraulic compensator	7ACFH0854		<ul style="list-style-type: none"> To be use with the Bizone Kit. If you don't have a buffer tank you can use this compensator. Easy to pair with our Bizone Kit. 14 kW ΔT 5°C – 28 kW ΔT 10°C
3 ways valve	7ACFH0855		<ul style="list-style-type: none"> 3 ways valve for heating and DHW
Magnetic dirt separator 1"	7ACFH0856		<ul style="list-style-type: none"> Dirt separator, swiveling, with magnetic ring
Antifreeze valve MM 1"	7ACFH0857		<ul style="list-style-type: none"> Ready to install Thermostatic valve Automatic opening (+ 3 ° C) and closing (+ 4 ° C) (+/- 1 ° C)
Automatic air vent 1"	7ACFH0862		<ul style="list-style-type: none"> Continuous degassing of air present in the hydraulic circuit Automatic operation Swivelling: horizontal or vertical mounting
Mix bottle 25 L	7ACFH0859		<ul style="list-style-type: none"> Insulated bottle, reversible: heating and cooling ErP class: C Usable volume: 25 L Wall installation
Mix bottle 50 L	7ACFH0858		<ul style="list-style-type: none"> Insulated bottle, reversible: heating and cooling ErP class: C Usable volume: 51 L Wall installation
Mix bottle 100 L	7ACFH0860		<ul style="list-style-type: none"> Insulated bottle, reversible: heating and cooling ErP class: C Usable volume: 95 L Floor installation
Mix bottle 200 L	7ACFH0861		<ul style="list-style-type: none"> Insulated bottle, reversible: heating and cooling ErP class: C Usable volume: 195 L Floor installation
Safety valve 10B 20X27	7ACFH0863		<ul style="list-style-type: none"> Installation power: 46 kW Graduated adjustment scale: 0.1 to 0.6 bar differential
Expansion vessel 12 L	7ACFH0864		<ul style="list-style-type: none"> CE standard vessel for heating and cooling circuit Capacity: 12 L Pre-inflation: 1 bar
Expansion vessel 18 L	7ACFH0865		<ul style="list-style-type: none"> CE standard vessel for heating and cooling circuit Capacity: 18 L Pre-inflation: 1 bar
Wall support for expansion vessel	7ACFH0866		<ul style="list-style-type: none"> Arm, vessel bracket, equipped with: <ul style="list-style-type: none"> - quick-release coupling for vessel - PR2 air bleed - NC valve with pressure gauge
Backflow preventer 1/2	7ACFH0867		<ul style="list-style-type: none"> Non-controllable reduced pressure zone backflow preventer NF

ACCESSORIES

DESIGNATION	PART NUMBER	PICTURE	FUNCTIONS
Condensate pump EVOSTA 2 4 to 7 mH ₂ O 180 mm	7ACFH0868		<ul style="list-style-type: none"> • Low consumption electronic circulator (EEI <= 0.18) • For heating and air conditioning • With limescale protection during commissioning • 5 year warranty • Flowrate: 0.4 to 3.6 m³ / h • Manometric head: 4 to 6.9 mWp • 3 operating curves each with 3 speeds: <ul style="list-style-type: none"> - Proportional differential pressure - Constant differential pressure - Constant speed • Protection class: IP X5
Axial thermometer 100 immersion 200	7ACFH0869		<ul style="list-style-type: none"> • Axial thermometer • Display 0/120°
Shock absorber (support)	7ACTL0510		<ul style="list-style-type: none"> • Helps reduce the transmission of vibrations. Length: 1 000mm
Line electrical heater - 3kW	7ACFH0822		<ul style="list-style-type: none"> • Provides additional heating when the heating demand is greater than the heat pump capacity
Remote control RCW29	7ACEL1896		<ul style="list-style-type: none"> • On/Off control, additional heating • Operating mode: cooling / heating / automatic • DHW parameters: forced mode / holiday / anti-legionella / DHW pump • Temperature parameter: water outlet, set temperature • Timer: 12/24h • On/Off timer, daily / weekly • Display of different temperatures • Probe values display • Fault codes • Maintenance mode
Temperature sensor	1PR070230		<ul style="list-style-type: none"> • Temperature sensor + cable (10m)
Cable extension (mixing tank)	7ACFH0870		<ul style="list-style-type: none"> • Connection between temperature sensor and electronic board for mixing tank probe
Cable extension (solar)	7ACFH0871		<ul style="list-style-type: none"> • Connection between temperature sensor and electronic board for solar probe
DHW electric heater control panel	7ACEL1892		<ul style="list-style-type: none"> • Control the DHW electric heater with the heat pump



DESIGNATION		DHW TANK 200L	DHW TANK 300L	DHW TANK 500L
Part number		7ACFH0872	7ACFH0873	7ACFH0874
Heat pump max. capacity	kW	10	16	22
Volume	L	196	273	475
Exchanger surface area	m ²	1.5	1.8	2.2
Material		enamelled steel	enamelled steel	enamelled steel
Max. pressure	bar	10	10	10
Static losses	W	51	63	80
Energy label		B	B	B
Protection		magnesium anode	magnesium anode	magnesium anode
Electric heater	kW	2.0	2.0	2.0
Height	mm	1215	1615	1705
Diameter	mm	640	640	790
Weight	kg	77	98	128



HIGH WALL

Range



	MODEL	REFERENCE	REFRI-GERANT TYPE	7 2	9 2.5	12 3.5	18 5	24 7	kBTU/h kW
p.54	 <p>HIGH WALL <i>A product adapted to extreme conditions</i></p>	HDHC Artica	R32		•	•	•	•	
									
p.56	 <p>HIGH WALL <i>Optimal design and comfort: new colour range, built-in ionizer, high filtration, Wi-Fi</i></p>	HDMB Harmonia	R32		•	•	•	•	
p.58	 <p>HIGH WALL <i>DC inverter High wall</i></p>	HDLA Aura	R32	•	•	•	•	•	
p.60	 <p>HIGH WALL <i>Built-in Wi-Fi</i></p>	HDLE Aura	R32	•	•	•	•	•	



DC Inverter
Reversible



HYBRID
HOUSE by Airwell



HDHC Artica

High wall - High efficiency & Energetic efficiency



RC18
included

+ PRODUCT

- RC18 remote control included (see page 130)
- Heating performance until -25°C
- Built-in Wi-Fi
- Compatible with ZDAA multisplit

FEATURES

TECHNOLOGY



4D AIRFLOW



GOLDEN FIN TREATMENT

AIR QUALITY/CLEAN



IONIZER



ANTIBACTERIAL FILTER



AUTO CLEAN/DRY

USER FUNCTIONS



Wi-Fi



24 H PROGRAMMABLE TIMER



I FEEL



NIGHT MODE



SUPER QUIET



REMOTE CONTROL LOCK



REFRIGERANT LEAKAGE DETECTOR



AUTO RESTART (MEMORY)

INSTALLER FUNCTIONS



ERROR CODE VIA INDOOR UNIT



AUTO-DIAGNOSTIC



LEFT/RIGHT CONDENSATE CONNECTION



HEATING ONLY MODE

CERTIFICATION

- AIRWELL participates in the ECP programme for ACI. Check ongoing validity of certificate: www.eurovent-certification.com



- Certified in Monosplit configuration

+ "SUSTAINABLE DEVELOPMENT"

- > High seasonal performance (SEER/SCOP).
- > Energy label A+++ in cooling mode and A++ in heating mode, guaranteeing energy savings.
- > Environment friendly R32 refrigerant.

+ "USER"

- > Multi-directional air louvers for air distribution throughout the room.
- > Wi-Fi included for remote control of the unit.
- > Low noise level ideal for living rooms (bedroom, office, living room, etc.).

+ "TECHNOLOGY"

- > Resistor in outdoor unit for heating performance and comfort down to -25°C.
- > Room sensor built into the remote control for better comfort ("I Feel" mode by pressing the TURBO button on the remote control for 7 s).
- > Automatic cleaning of heat exchangers for better hygiene and performance.
- > Golden Fin treatment on the heat exchangers (external and internal) for protection against corrosion and durability over time.

+ "INSTALLER"

- > Installer mode for operating parameters reading.
- > Technician mode for adjusting certain operating parameters.
- > Condensate drain to the right or left for ease of installation in the room.
- > Spirit level built into the wall bracket.
- > Mobile strut on the rear of the unit for easy connections.
- > Easy access to the condensate pan for servicing.



AirHome connectivity

See technical draws page 147

High-performance at extreme temperatures:

- > Heating function down to -25°C.



TECHNICAL DATA

HDHC Artica

High wall

INDOOR UNIT		HDHC-025N-09M25	HDHC-035N-09M25	HDHC-050N-09M25	HDHC-070N-09M25
Part number		7SP023280	7SP023281	7SP023282	7SP023283
Phase		Single-phase	Single-phase	Single-phase	Single-phase
COOLING					
Rated power (min./max.)	kW	2.73 (1.32~3.81)	3.52 (1.32~3.96)	5.28 (1.99~6.13)	7.03 (2.11~8.21)
Pdesignc	kW	2.60	3.50	5.30	7.00
Rated power input	kW	0.73	1.21	1.55	2.60
SEER/Energy label		8.6/A+++	8.5/A+++	8.5/A+++	8.5/A+++
Operating limits	°C	-15~50° Dry bulb			

HEATING					
Rated power (min./max.)	kW	3.14 (0.88~4.40)	3.96 (0.88~4.54)	5.57 (1.35~6.77)	7.33 (1.55~8.21)
Pdesignh (average climate)	kW	2.40	2.40	4.30	5.00
Pdesignh (warmer climate)	kW	2.40	2.50	4.30	5.50
Pdesignh (colder climate)	kW	3.60	3.60	6.40	7.30
Rated power input	kW	0.69	0.99	1.50	1.97
SCOP/Energy label (average climate)		4.6/A++	4.6/A++	4.3/A+	4.2/A+
SCOP/Energy label (warmer climate)		5.1/A+++	5.1/A+++	5.4/A+++	5.3/A+++
SCOP/Energy label (colder climate)		3.8/A	3.8/A	3.6/A	3.3/B
Operating limits	°C	-25~24° Dry bulb			
Power at -7°C	kW	3.42	3.47	4.78	6.76
Power at -10°C	kW	3.26	3.31	4.56	6.45
Power at -15°C	kW	3.06	3.10	4.27	6.04

INDOOR UNIT					
Sound pressure level at 1 m (VL/LS/MS/HS)	dB(A)	20/22/32/37	21/22/33/40	22/23/35/41	21/33/40/44
Sound level	dB(A)	58	59	59	64
Airflow (LS/MS/HS)	m³/h	280/360/530	290/380/560	400/580/685	379/724/1092
Dehumidification	l/h	1.00	1.20	1.80	2.40
Outline dimensions (WxHxD)	mm	855x297x231	855x297x231	1023x319x245	1196x370x275
Package dimensions (WxHxD)	mm	920x305x370	920x305x370	1095x325x400	1280x355x455
Net weight/Gross weight	kg	11/14.2	11/14.2	13.2/17.7	21.1/29.3

OUTDOOR UNIT		YDAC-025R-09M25	YDAC-035R-09M25	YDAC-050R-09M25	YDAC-070R-09M25
Part number		7SP063220	7SP063221	7SP063222	7SP063223
Sound pressure level at 1 m	dB(A)	53	53	54	58.5
Sound level	dB(A)	64	65	65	67
Airflow	m³/h	2200	2200	3500	3500
Compressor type		Rotary	Rotary	Rotary	Rotary
Outline dimensions (WxHxD)	mm	805x554x330	805x554x330	890x673x342	890x673x342
Package dimensions (WxHxD)	mm	915x615x370	915x615x370	995x740x398	995x740x398
Net weight/Gross weight	kg	28.4/31	28.4/31	38.8/41.9	45.6/48.8

POWER SUPPLY					
Phase/Voltage/Frequency		1P/220-240V/50Hz	1P/220-240V/50Hz	1P/220-240V/50Hz	1P/220-240V/50Hz
Power supply side		Outdoor	Outdoor	Outdoor	Outdoor
Power cable section	mm²	3G1.5	3G1.5	3G1.5	3G2.5
Fuse rating am	A	16	16	16	20
Electrical connections in/out	mm²	5G1.5	5G1.5	5G1.5	5G1.5

PIPE LINE					
Suction pipe diameter	inches	3/8"	3/8"	1/2"	5/8"
Liquid pipe diameter	inches	1/4"	1/4"	1/4"	3/8"
Max. length	m	25	25	30	50
Max. height	m	10	10	20	25
Refrigerant/GWP		R32/675	R32/675	R32/675	R32/675
Charge (5 m)	kg	0.69	0.69	1.1	1.5
Additional charge	g/m	12	12	12	24

MATCHING

INDOOR UNIT	COMPATIBLE WITH OUTDOOR UNIT	
HIGH WALL	MONOSPLIT	MULTISPLIT
 <p>HDHC Artica</p>	 <p>YDAC</p>	 <p>ZDAA</p>



DC Inverter
Reversible



HYBRID
HOUSE by Airwell



HDMB HARMONIA

Colour range High wall



RC19
included

Complete sets:



HDMB Harmonia White



HDMB Harmonia Mirror



HDMB Harmonia Grey

+ PRODUCT

- RC19 remote control included (see page 132)
- Design
- Performance
- Air quality (ionizer + filters)
- Quiet
- Compatible with YDZC and ZDAA multisplits

FEATURES

TECHNOLOGY



4D AIRFLOW



GOLDEN FIN TREATMENT

AIR QUALITY/CLEAN



IONIZER



ANTIBACTERIAL FILTER



AUTO CLEAN/DRY

USER FUNCTIONS



Wi-Fi



24 H



I FEEL



NIGHT MODE



SUPER QUIET



REMOTE CONTROL LOCK



REFRIGERANT LEAKAGE DETECTOR



AUTO RESTART (MEMORY)

INSTALLER FUNCTIONS



ERROR CODE VIA INDOOR UNIT



AUTO-DIAGNOSTIC



LEFT/RIGHT CONDENSATE CONNECTION



HEATING ONLY MODE

CERTIFICATION

- AIRWELL participates in the ECP programme for AC1. Check ongoing validity of certificate:

www.eurovent-certification.com



www.eurovent-certification.com

- Certified in Monosplit configuration

Build your device:

1 CHOOSE COLOR OF YOUR INDOOR UNIT



HDMB Harmonia White



HDMB Harmonia Grey

2 THEN SELECT THE PANEL COLOUR REFERENCE



Silver Grey



Champagne Beige



Passion Red

+ "SUSTAINABLE DEVELOPMENT"

- > High seasonal performance (SEER/SCOP).
- > Energy label A+++ in cooling mode and A++ in heating mode depending on model, guaranteeing energy savings.
- > Environment friendly R32 refrigerant.

+ "USER"

- > Contemporary design to fit any interior.
- > High-performance ionizer and filters for better air quality.
- > Multi-directional air louvers for air distribution throughout the room.
- > Wi-Fi included for remote control of the unit.
- > Low noise level ideal for living rooms (bedroom, office, living room, etc.).

+ "TECHNOLOGY"

- > Room sensor built into the remote control for better comfort ("I Feel" mode).
- > Automatic cleaning of heat exchangers for better hygiene and performance.
- > Golden Fin treatment on the heat exchangers (external and internal) for protection against corrosion and durability over time.

+ "INSTALLER"

- > Installer mode for operating parameters reading.
- > Technician mode for adjusting certain operating parameters.
- > Condensate drain to the right or left for ease of installation in the room.





See technical draws page 148

TECHNICAL DATA

INDOOR UNIT - WHITE		HDMB-025N-09M22	HDMB-035N-09M22	HDMB-050N-09M22	HDMB-070N-09M22
Indoor unit part number - White		7SP023235	7SP023236	7SP023237	7SP023238
INDOOR UNIT - GREY		HDMB-025N-09M22-GY	HDMB-035N-09M22-GY	HDMB-050N-09M22-GY	HDMB-070N-09M22-GY
Indoor unit part number - Grey		7SP023244	7SP023245	7SP023246	7SP023247
INDOOR UNIT - MIRROR		HDMB-025N-09M22-MR	HDMB-035N-09M22-MR	HDMB-050N-09M22-MR	HDMB-070N-09M22-MR
Indoor unit part number - Mirror		7SP023240	7SP023241	7SP023242	7SP023243
Phase		Single-phase	Single-phase	Single-phase	Single-phase
COOLING					
Rated power (min./max.)	kW	2.64 (1.02~3.22)	3.51 (1.37~4.29)	5.27 (3.39~5.90)	7.03 (2.11~8.21)
Pdesignc	kW	2.60	3.50	5.30	7.00
Rated power input	kW	0.61	0.98	1.55	2.51
SEER/Energy label		9.3/A+++	8.5/A+++	7.0/A++	6.5/A++
Operating limits	°C	-15~50° Dry bulb			
HEATING					
Rated power (min./max.)	kW	2.92 (0.82~3.37)	3.81 (1.07~4.38)	5.57 (3.10~5.85)	7.33 (1.55~8.21)
Pdesignh (average climate)	kW	2.40	2.60	4.10	4.90
Pdesignh (warmer climate)	kW	2.70	3.00	4.50	5.30
Rated power input	kW	0.64	0.98	1.50	2.13
SCOP/Energy label (average climate)		4.6/A++	4.6/A++	4.0/A+	4.0/A+
SCOP/Energy label (warmer climate)		6.0/A+++	6.1/A+++	5.1/A+++	5.1/A+++
Operating limits	°C	-15~24° Dry bulb			
Power at -7°C	kW	2.78	3.18	4.73	7.20
Power at -10°C	kW	2.65	3.03	4.52	6.87
Power at -15°C	kW	2.48	2.84	4.23	6.43
INDOOR UNIT					
Sound pressure level at 1 m (VL/LS/MS/HS)	dB(A)	20/24/29/36	21/25/33/39	22/28/33/43	25/30/41/47
Sound level	dB(A)	55	55	58	63
Airflow (LS/MS/HS)	m³/h	303/362/483	395/477/584	420/500/730	640/830/1020
Dehumidification	l/h	0.9	1.2	1.8	2.4
Outline dimensions (WxHxD)	mm	802x297x189	802x297x189	965x319x215	1080x335x226
Package dimensions (WxHxD)	mm	875x380x285	875x380x285	1045x410x305	1155x320x415
Net weight/Gross weight	kg	8.6/11.1	8.6/11.1	10.9/14.2	13.7/17.3
PANEL					
Panel part number - Silver Grey		7ACTL0551	7ACTL0551	7ACTL0552	7ACTL0553
Panel part number - Champagne Beige		7ACTL0543	7ACTL0543	7ACTL0544	7ACTL0545
Panel part number - Passion Red		7ACTL0547	7ACTL0547	7ACTL0548	7ACTL0549

OUTDOOR UNIT		YDAB-025H-09M22	YDAB-035H-09M22	YDAB-050H-09M22	YDAB-070H-09M22
Part number		7SP063155	7SP063156	7SP063157	7SP063158
Sound pressure level at 1 m	dB(A)	49	51	53	55
Sound level	dB(A)	60	62	64	66
Airflow	m³/h	2150	2200	2100	3500
Compressor type		Rotary	Rotary	Rotary	Rotary
Outline dimensions (WxHxD)	mm	765x555x303	765x555x303	805x554x330	890x673x342
Package dimensions (WxHxD)	mm	887x610x337	887x610x337	915x615x370	995x740x398
Net weight/Gross weight	kg	26.4/29.5	26.4/29.5	32.8/36.2	43.9/46.9
POWER SUPPLY					
Phase/Voltage/Frequency		1P/220-240V/50-60Hz	1P/220-240V/50-60Hz	1P/220-240V/50-60Hz	1P/220-240V/50-60Hz
Power supply side		Outdoor	Outdoor	Outdoor	Outdoor
Power cable section	mm²	3G1.5	3G1.5	3G1.5	3G2.5
Fuse rating am	A	16	16	16	20
Electrical connections in/out	mm²	5G1.5	5G1.5	5G1.5	5G1.5
PIPE LINE					
Suction pipe diameter	inches	3/8"	3/8"	1/2"	5/8"
Liquid pipe diameter	inches	1/4"	1/4"	1/4"	3/8"
Max. length	m	25	25	30	50
Max. height	m	10	10	20	25
Refrigerant/GWP		R32/675	R32/675	R32/675	R32/675
Charge (5 m)	kg	0.62	0.62	1.10	1.45
Additional charge	g/m	12	12	12	24

OPTIONS

ACCESSORY	PART NUMBER	PICTURE	FUNCTION
Wired remote control RCW22	7ACEL1778		<ul style="list-style-type: none"> Weekly timer, mode, fan speed, On/Off timer, "I Feel" function, temperature.
Dry On/Off contact adapter (mandatory with RCW22)	7ACEL1788		<ul style="list-style-type: none"> Air conditioning external control.
Condensate pump FlowwatchDesign (gutter)	7ACTL0518		<ul style="list-style-type: none"> Condensate evacuation from indoor units.

MATCHING

INDOOR UNIT
HIGH WALL



HDMB Colour range

▼

COMPATIBLE WITH OUTDOOR UNIT

MONOSPLIT	MULTISPLIT
	
YDAB	ZDAA

HDMB Harmonia - Colour range

High wall



DC Inverter
Reversible



HYBRID
HOUSE by Airwell



HDLA AURA

High wall



RC19
included

+ PRODUCT

- RC19 remote control included (see page 132)
- Design
- Performance
- Compatible with YDZC and ZDAA multisplits

FEATURES

TECHNOLOGY



GOLDEN FIN
TREATMENT

AIR QUALITY/CLEAN



ANTIBACTERIAL
FILTER



AUTO
CLEAN/DRY

USER FUNCTIONS



24 H
PROGRAMMABLE
TIMER



I FEEL



NIGHT
MODE



SUPER
QUIET



REMOTE CONTROL
LOCK



REFRIGERANT
LEAKAGE DETECTOR



RESTART
(MEMORY)

INSTALLER FUNCTIONS



ERROR CODE VIA
INDOOR UNIT



AUTO-DIAGNOSTIC



LEFT/RIGHT
CONDENSATE
CONNECTION



HEATING
ONLY
MODE

CERTIFICATION

- AIRWELL participates in the ECP programme for AC1. Check ongoing validity of certificate:
www.eurovent-certification.com



- Certified in Monosplit configuration

+ "SUSTAINABLE DEVELOPMENT"

- > Energy label A++ in cooling mode and A+ in heating mode depending on model, guaranteeing energy savings.
- > Environment friendly R32 refrigerant.

+ "USER"

- > Modern and sleek design.
- > High-performance filters that trap dust and particles for better air quality.

+ "TECHNOLOGY"

- > Room sensor built into the remote control for better comfort ("I Feel" mode).
- > Automatic cleaning and drying of the indoor unit for better hygiene.
- > Golden Fin treatment on the heat exchangers (external and internal) for protection against corrosion and durability over time.

+ "INSTALLER"

- > Installer mode for direct reading of the probes on the indoor unit.
- > Technician mode for adjusting certain operating parameters.
- > Condensate drain to the right or left for ease of installation in the room.

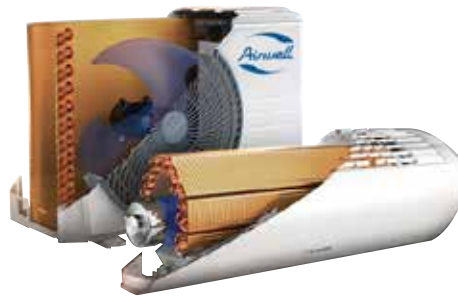

Longer product service life:

- > Golden Fin exchanger.
- > Anti-corrosion treatment on PCB.



OPTIONS

ACCESSORY	PART NUMBER	PICTURE	FUNCTION
Wired remote control RCW8	7ACEL1706		• Fan speed mode, timer, on/off, temperature and swing.
AirHome Wi-Fi module	7ACEL1744		• Control air conditioners with your smartphone, tablet or computer via a wireless router and internet.
Condensate pump FlowwatchDesign (gutter)	7ACTL0518		• Condensate evacuation from indoor units.

See technical draws page 149

TECHNICAL DATA

HDLA Aura

High wall

		NEW				
INDOOR UNIT		HDLA-022N-09M25	HDLA-025N-09M25	HDLA-035N-09M25	HDLA-050N-09M25	HDLA-070N-09M25
Part number		7SP023249	7SP023250	7SP023251	7SP023252	7SP023253
Phase		Single-phase	Single-phase	Single-phase	Single-phase	Single-phase
COOLING						
Rated power (min./max.)	kW	2.05 (0.71~2.64)	2.64 (0.91~3.40)	3.52 (1.11~4.16)	5.28 (1.82~6.16)	7.03 (2.08~7.91)
Pdesignc	kW		2.80	3.60	5.20	7.00
Rated power input	kW		0.73	1.21	1.55	2.60
SEER/Energy label			6.3/A++	6.1/A++	7.4/A++	6.1/A++
Operating limits	°C	-15~50° Dry bulb				
HEATING						
Rated power (min./max.)	kW	2.34 (0.66~2.70)	2.93 (0.821~3.370)	3.81 (1.08~4.22)	5.57 (1.29~6.74)	7.33 (1.61~7.91)
Pdesignh (average climate)	kW		2.60	2.70	4.10	4.80
Pdesignh (warmer climate)			2.60	2.50	4.40	5.80
Rated power input	kW		0.73	1.09	1.57	2.40
SCOP/Energy label (average climate)			4.0/A+	4.0/A+	4.0/A+	4.0/A+
SCOP/Energy label (warmer climate)			5.1/A+++	5.1/A+++	5.1/A+++	4.8/A++
Operating limits	°C	-15~30° Dry bulb				
Power at -7°C	kW		2.29	2.39	3.68	4.25
Power at -10°C	kW		2.03	2.04	3.40	3.89
Power at -15°C	kW		1.63	1.64	2.72	3.11
INDOOR UNIT						
Sound pressure level at 1 m (VL/LS/MS/HS)	dB(A)	21/26/30/40	21/25/32/38.5	21/25/34.5/40.5	20/26/36/42.5	36/40.5/45
Sound level	dB(A)	54	54	55	56	59
Airflow (LS/MS/HS)	m³/h	325/360/460	325/360/466	325/430/540	540/680/840	662/817/980
Dehumidification	l/h	0.7	0.9	1.2	1.8	2.4
Outline dimensions (WxHxD)	mm	805x285x194	805x285x194	805x285x194	957x302x213	1040x327x220
Package dimensions (WxHxD)	mm	870x365x270	870x365x270	870x365x270	1035x385x295	1120x315x405
Net weight/Gross weight	kg	7.5/9.8	7.5/9.8	7.6/9.9	10.0/12.1	12.3/15.8
OUTDOOR UNIT						
		-	YDAA-025H-09M25	YDAA-035H-09M25	YDAA-050H-09M25	YDAA-070H-09M25
Part number		-	7SP063160	7SP063161	7SP063162	7SP063163
Sound pressure level at 1 m	dB(A)		51	52	52	56
Sound level	dB(A)		62	63	63	67
Airflow	m³/h		1750	1800	2100	3500
Compressor type			Rotary	Rotary	Rotary	Rotary
Outline dimensions (WxHxD)	mm		720x495x270	720x495x270	805x554x330	890x673x342
Package dimensions (WxHxD)	mm		835x540x300	835x540x300	915x615x370	995x740x398
Net weight/Gross weight	kg		23.2/25	23.2/25.2	32.7/35.5	42.9/45.7
POWER SUPPLY						
Phase/Voltage/Frequency			1P/220-240V/50Hz	1P/220-240V/50Hz	1P/220-240V/50Hz	1P/220-240V/50Hz
Power supply side			Outdoor	Outdoor	Outdoor	Outdoor
Power cable section	mm²		3x1.5	3x1.5	3x1.5	3x2.5
Fuse rating am (D curve)	A		10	10	16	20
Shielded electrical connections	mm²		1.5x5	1.5x5	1.5x5	2.5x5
PIPE LINE						
Suction pipe diameter	inches	3/8"	3/8"	3/8"	1/2"	5/8"
Liquid pipe diameter	inches	1/4"	1/4"	1/4"	1/4"	3/8"
Max. length	m		25	25	30	50
Max. height	m		10	10	20	25
Refrigerant/GWP			R32/675	R32/675	R32/675	R32/675
Charge (5 m)	kg		0.55	0.55	1.08	1.42
Additional charge	g/m		12	12	12	24

MATCHING





DC Inverter
Reversible



HYBRID
HOUSE by Airwell



HDLE AURA

High wall - Built-in Wi-Fi



RC08A
included

+ PRODUCT

- RC08A remote control included (see page 128)
- Wide range from 2 to 6 kW
- Wi-Fi compatible (AirHome solution)
- Compatible with ZDAE multisplit

FEATURES

AIR QUALITY/CLEAN



AUTO CLEAN/DRY

USER FUNCTIONS



Wi-Fi



PROGRAMMABLE
TIMER



I FEEL



NIGHT MODE



REMOTE CONTROL
LOCK



AUTO RESTART
(MEMORY)

INSTALLER FUNCTIONS



ERROR CODE VIA
INDOOR UNIT



AUTO-DIAGNOSTIC



LEFT/RIGHT
CONDENSATE
CONNECTION



DRY CONTACT
ON/OFF

CERTIFICATION

- AIRWELL participates in the ECP programme for AC1. Check ongoing validity of certificate:
www.eurovent-certification.com



- Certified in Monosplit configuration

+ “SUSTAINABLE DEVELOPMENT”

- > Energy label A++ in cooling mode and A+ in heating mode depending on model, guaranteeing energy savings.
- > Environment friendly R32 refrigerant.

+ “USER”

- > Modern and sleek design.
- > High-performance filters that trap dust and particles for better air quality.

+ “TECHNOLOGY”

- > Room sensor built into the remote control for better comfort (“I Feel” mode).
- > Automatic cleaning and drying of the indoor unit for better hygiene.

+ “INSTALLER”

- > Condensate drain to the right or left for ease of installation in the room.



AirHome connectivity

Night mode:

- > Improved comfort and energy savings

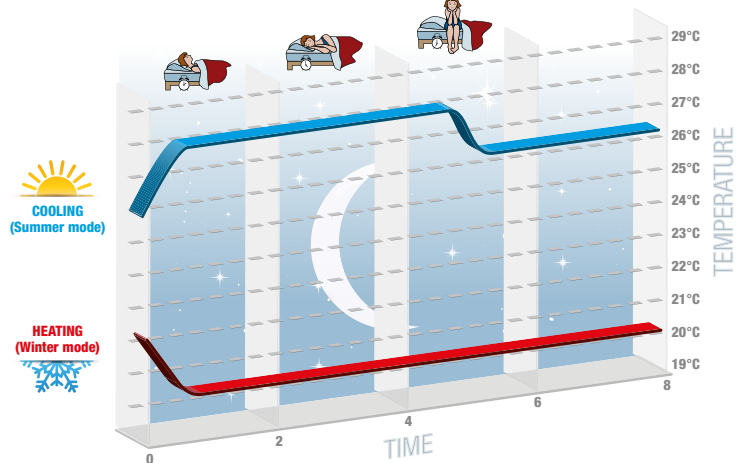

OPTIONS

ACCESSORY

Wired remote control RCW27
(see page 138)

PART NUMBER

7ACEL1874

PICTURE



FUNCTION

- Weekly programming, mode setting, temperature setting, fan speed, key lock.

See technical draws page 149

TECHNICAL DATA

HDLE Aura

High wall

INDOOR UNIT		HDLE-022N-09M25	HDLE-025N-09M25	HDLE-035N-09M25	HDLE-050N-09M25	HDLE-070N-09M25
Part number		7SP023270	7SP023271	7SP023272	7SP023273	7SP023274
Phase		Single-phase	Single-phase	Single-phase	Single-phase	Single-phase

COOLING						
Rated power (min./max.)	kW	2.20 (0.30-2.85)	2.70 (0.60-3.40)	3.20 (0.90-3.60)	4.60 (1.00-5.30)	6.20 (1.80-6.90)
Pdesignnc	kW	2.20	2.70	3.20	4.60	6.20
Rated power input	kW	0.59	0.74	0.99	1.36	1.83
SEER/Energy label		6.6/A++	6.6/A++	6.1/A++	6.4/A++	6.8/A++
Operating limits	°C	-15°~43°C Dry bulb				

HEATING						
Rated power (min./max.)	kW	2.40 (0.60-2.90)	2.80 (0.60-3.70)	3.40 (0.90-4.00)	5.20 (1.00-5.65)	6.50 (1.30-7.03)
Pdesignnh (average climate)	kW	2.10	2.60	2.70	3.70	4.70
Pdesignnh (warmer climate)		2.10	2.80	2.80	3.60	4.70
Rated power input	kW	0.59	0.70	0.92	1.34	1.91
SCOP/Energy label (average climate)		4.0/A+	4.2/A+	4.0/A+	4.0/A+	4.0/A+
SCOP/Energy label (warmer climate)		4.8/A++	5.2/A+++	4.9/A++	5.1/A+++	5.1/A+++
Operating limits	°C	-15°~24°C Dry bulb				
Power at -7°C	kW	2.28	2.60	3.16	4.42	5.15
Power at -10°C	kW	2.20	2.57	3.12	4.16	4.50
Power at -15°C	kW	1.94	2.27	2.75	3.74	4.39

INDOOR UNIT						
Sound pressure level at 1 m (LS/MS/HS)	dB (A)	22/36/39	21/38/41	21/38/41	27/42/44	26/45/48
Sound level (LS/MS/HS)	dB (A)	37/48/55	36/50/57	34/50/57	41/52/54	42/57/60
Airflow (LS/MS/HS)	m³/h	290/470/500	280/520/550	280/480/590	550/800/850	400/800/900
Dehumidification	l/h	0.60	1.40	1.40	1.80	1.80
Outline dimensions (WxHxD)	mm	713x270x195	790x275x200	790x275x200	970x300x224	970x300x224
Package dimensions (WxHxD)	mm	776x362x268	866x367x271	866x367x271	1041x383x320	1041x383x320
Net weight/Gross weight	kg	8/9.5	9/11	9/11	13.5/16	13/15.5

OUTDOOR UNIT		YDAE-022R-09M25	YDAE-025R-09M25	YDAE-035R-09M25	YDAE-050R-09M25	YDAE-070R-09M25
Part number		7SP063200	7SP063201	7SP063202	7SP063203	7SP063204
Sound pressure level at 1 m	dB (A)	49	51	51	52	54
Sound level	dB (A)	60	62	64	63	65
Airflow	m³/h	1400	1950	1950	1950	2800
Compressor type		Rotary	Rotary	Rotary	Rotary	Rotary
Outline dimensions (WxHxD)	mm	710x450x293	732x550x330	732x550x330	732x555x330	873x555x376
Package dimensions (WxHxD)	mm	764x525x330	792x620x393	792x620x393	794x615x376	951x620x431
Net weight/Gross weight	kg	21/23	25/27.5	25/27.5	26.5/29	36.5/39.5

POWER SUPPLY						
Phase/Voltage/Frequency		1P/220-240V/50Hz	1P/220-240V/50Hz	1P/220-240V/50Hz	1P/220-240V/50Hz	1P/220-240V/50Hz
Power supply side		Outdoor	Outdoor	Outdoor	Outdoor	Outdoor
Power cable section	mm²	3G1.5	3G1.5	3G1.5	3G1.5	3G1.5
Fuse rating am	A	16	16	16	16	16
Electrical connections in/out	mm²	4G1.5	4G1.5	4G1.5	4G1.5	4G1.5

PIPE LINE						
Suction pipe diameter	inches	3/8"	3/8"	3/8"	3/8"	1/2"
Liquid pipe diameter	inches	1/4"	1/4"	1/4"	1/4"	1/4"
Max. length	m	15	15	15	25	25
Max. height	m	10	10	10	10	10
Refrigerant/GWP		R32/675	R32/675	R32/675	R32/675	R32/675
Charge (5 m)	kg	0.45	0.53	0.55	0.75	1.23
Additional charge	g/m	16	16	16	16	16

MATCHING





MULTISPLIT

Range



OUTDOOR UNITS

REFRIGERANT TYPE

KW

p.64



ZDAA

R32

5,3 to 13

ZDAA

Compatible with: HDHC Artica, HDMB Harmonia and HDLA high wall, XDMX console, FDMX floor ceiling, DDMX ducted and CDMX cassette

p.76



ZDAE

R32

4,1 to 12

ZDAE

Compatible with: HDLE Aura high wall and XDLF console

Multisplit

INDOOR UNITS

OUTDOOR UNITS	NB MAX OF IDU	HIGH WALL HDHC ARTICA	HIGH WALL HDMB HARMONIA	HIGH WALL HDLA	CONSOLE XDMX	FLOOR CEILING FDMX	DUCTED DDMX	CASSETTE CDMX
ZDAA-2040	2	Sizes 25/35/50	Sizes 25/35/50	Sizes 22/25/35/50	Sizes 35/50	Size 50	Sizes 22/35/50	Sizes 22/25/35/50
ZDAA-2050	2	Sizes 25/35/50	Sizes 25/35/50	Sizes 22/25/35/50	Sizes 35/50	Size 50	Sizes 22/35/50	Sizes 22/25/35/50
ZDAA-3080	3	Sizes 25/35/50	Sizes 25/35/50	Sizes 22/25/35/50	Sizes 35/50	Size 50	Sizes 22/35/50	Sizes 22/25/35/50
ZDAA-4090	4	Sizes 25/35/50/70	Sizes 25/35/50/70	Sizes 22/25/35/50/70	Sizes 35/50	Sizes 50/70	Sizes 22/35/50/70	Sizes 22/25/35/50/70
ZDAA-5130	5	Sizes 25/35/50/70	Sizes 25/35/50/70	Sizes 22/25/35/50/70	Sizes 35/50	Sizes 50/70	Sizes 22/35/50/70	Sizes 22/25/35/50/70

OUTDOOR UNITS	NB MAX OF IDU	HIGH WALL HDLE AURA	CONSOLE XDLF
ZDAE-2040	2	Sizes 22/25/35/50	Sizes 25/35/50
ZDAE-2050	2	Sizes 22/25/35	Sizes 25/35
ZDAE-3060	3	Sizes 22/25/35/50	Sizes 25/35/50
ZDAE-3070	3	Sizes 22/25/35/50	Sizes 25/35/50
ZDAE-4080	4	Sizes 22/25/35/50	Sizes 25/35/50
ZDAE-5130	5	Sizes 22/25/35/50/70	Sizes 25/35/50



DC Inverter
Reversible



HYBRID
HOUSE by Airwell



ZDAA Multisplit



+ PRODUCT

- Flexy Match (compatible with most of the range)
- Total piping length up to 80 m
- High capacity compared with market average
- Electronic expansion valve

FEATURES

TECHNOLOGY



ELECTRONIC EXPANSION VALVE



GOLDEN FIN TREATMENT

INSTALLER FUNCTIONS



AUTO-DIAGNOSTIC

CERTIFICATION

- AIRWELL participates in the ECP programme for AC1. Check ongoing validity of certificate: www.eurovent-certification.com



- Models marked * are not Eurovent certified

Compatible WITH:

- > High wall HDHC Artica 25/35/50/70



- > High wall HDMB Harmonia 25/35/50/70



White



Mirror



Grey

- > High wall HDLA 22/25/35/50/70



- > Console XDMX 35/50



- > Floor ceiling FDMX 50/70



- > Ducted DDMX 22/35/50/70



- > Cassette CDMX 22/25/35/50/70



+ "SUSTAINABLE DEVELOPMENT"

- > High energy label A++ (cooling mode) / A+ (heating mode).
- > Energy savings (heating mode only, setpoint limits).

+ "USER"

- > A large choice of indoor units.
- > Small footprint with a single outdoor unit.

+ "INSTALLER"

- > Scalable and flexible installation.
- > Long piping.

+ "TECHNOLOGY"

- > High corrosion resistance with the Golden Fin.
- > Refrigerant leak detection.



Longer product service life:

- > Golden Fin exchanger.
- > Anti-corrosion treatment on PCB.

See technical draws page 151

TECHNICAL DATA

NEW

OUTDOOR UNIT		ZDAA-2040-09M25	ZDAA-2050-09M25	ZDAA-3080-09M25	ZDAA-4090-09M25*	ZDAA-5130-09M25*
Part number		7SP091194	7SP091195	7SP091196	7SP091197	7SP091198
Phase		Single-phase	Single-phase	Single-phase	Single-phase	Single-phase

ZDAA

COOLING

Rated power (min./max.)	kW	4.10 (1.47-4.69)	5.28 (2.28-5.70)	7.91 (3.08-8.21)	10.55 (2.05-10.55)	12.31 (3.17-12.31)
Pdesignc	kW	4.10	5.30	7.90	10.50	12.30
Rated power input	kW	1.27	1.63	2.45	3.52	3.81
SEER/Energy label		6.1/A++	6.3/A++	6.3/A++	6.3/A++	6.1/A++
Operating limits	°C	-15°/50° Dry bulb				

HEATING

Rated power (min./max.)	kW	4.40 (1.62-4.99)	5.57 (2.40-5.74)	8.21 (2.40-8.21)	10.55 (2.34-11.14)	12.31 (3.37-12.31)
Pdesignh (average climate)	kW	3.90	4.50	5.70	8.80	9.50
Pdesignh (warmer climate)		4.10	5.00	6.00	9.80	9.80
Rated power input	kW	1.18	1.50	2.21	2.88	3.31
SCOP/Energy label (average climate)		3.8/A	4.0/A+	4.0/A+	4.0/A+	3.8/A
SCOP/Energy label (warmer climate)		5.1/A+++	5.1/A+++	5.1/A+++	5.1/A+++	5.1/A+++
Power at -7°C	kW	4.09	4.90	6.73	8.23	8.74
Power at -10°C	kW	3.21	3.62	5.66	6.86	7.39
Power at -15°C	kW	2.86	3.23	5.09	6.44	7.02
Operating limits	°C	-15°/24° Dry bulb				

OUTDOOR UNIT

Sound pressure level at 1 m	dB(A)	54	54	56	57	56
Sound level	dB(A)	65	65	68	69	69
Airflow	m³/h	2100	2100	3000	4000	3850
Compressor type		Rotary	Rotary	Rotary	Rotary	Rotary
Outline dimensions (WxHxD)	mm	805x554x330	805x554x330	890x673x342	946x810x410	946x810x410
Package dimensions (WxHxD)	mm	915x615x370	915x615x370	1030x750x438	1090x875x500	1090x875x500
Net weight/Gross weight	kg	32/35	35/38	48/51.8	68.8/75.6	73.3/80.4

POWER SUPPLY

Phase/Voltage/Frequency		1P/230V/50Hz	1P/230V/50Hz	1P/230V/50Hz	1P/230V/50Hz	1P/230V/50Hz
Power supply side		Outdoor	Outdoor	Outdoor	Outdoor	Outdoor
Power cable section	mm²	3G1.5	3G1.5	3G2.5	3G4	3G4
Fuse rating am	A	16	16	20	25	25
Electrical connections in/out	mm²	2 x (4G1.5)	2 x (4G1.5)	3x (4G1.5)	4 x (4G1.5)	5 x (4G1.5)

PIPE LINE

Suction pipe diameter	inches	2x3/8"	2x3/8"	3x3/8"	3x3/8"+1x1/2"	4x3/8"+1x1/2"
Liquid pipe diameter	inches	2x1/4"	2x1/4"	3x1/4"	4x1/4"	5x1/4"
Max. length	m	40	40	60	80	80
Max. length per circuit	m	25	25	30	35	35
Max. height between indoor and outdoor unit	Outdoor unit higher than indoor unit	m	15	15	15	15
	Outdoor unit lower than indoor unit	m	15	15	15	15
Max. height between indoor units	m	10	10	10	10	10
Refrigerant/GWP		R32/675	R32/675	R32/675	R32/675	R32/675
Charge	kg	1.10	1.25	1.85	2.10	2.90
Totale length charge	m	15	15	22.5	30	37.5
Additional charge	g/m	12	12	12	12	12

Multisplit



High wall HDHC Artica
25/35/50/70

INDOOR UNIT		HDHC-025N-09M25	HDHC-035N-09M25	HDHC-050N-09M25	HDHC-070N-09M25
Part number		7SP023280	7SP023281	7SP023282	7SP023283
Phase		Single-phase	Single-phase	Single-phase	Single-phase
Cooling rated power	kW	2.73	3.52	5.28	7.03
Heating rated power	kW	3.14	3.96	5.57	7.33
Sound pressure level at 1 m (VL/LS/MS/HS)	dB(A)	20/22/32/37	21/22/33/40	22/23/35/41	21/33/40/44
Sound level	dB(A)	58	59	59	64
Airflow (LS/MS/HS)	m ³ /h	280/360/530	290/380/560	400/580/685	379/724/1092
Dehumidification	l/h	1.00	1.20	1.80	2.40
Outline dimensions (WxHxD)	mm	855x297x231	855x297x231	1023x319x245	1196x370x275
Package dimensions (WxHxD)	mm	920x305x370	920x305x370	1095x325x400	1280x355x455
Net weight/Gross weight	kg	11/14.2	11/14.2	13.2/17.7	21.1/29.3

PIPE LINE

Suction pipe diameter	inches	3/8"	3/8"	1/2"	5/8"
Liquid pipe diameter	inches	1/4"	1/4"	1/4"	3/8"



High wall
HDMB Harmonia
White 25/35/50/70



High wall
HDMB Harmonia
Mirror 25/35/50/70



High wall
HDMB Harmonia
Grey 25/35/50/70

INDOOR UNIT - WHITE		HDMB-025N-09M22	HDMB-035N-09M22	HDMB-050N-09M22	HDMB-070N-09M22
Indoor unit part number - White		7SP023235	7SP023236	7SP023237	7SP023238
INDOOR UNIT - GREY		HDMB-025N-09M22-GY	HDMB-035N-09M22-GY	HDMB-050N-09M22-GY	HDMB-070N-09M22-GY
Indoor unit part number - Grey		7SP023244	7SP023245	7SP023246	7SP023247
INDOOR UNIT - MIRROR		HDMB-025N-09M22-MR	HDMB-035N-09M22-MR	HDMB-050N-09M22-MR	HDMB-070N-09M22-MR
Indoor unit part number - Mirror		7SP023240	7SP023241	7SP023242	7SP023243
Phase		Single-phase	Single-phase	Single-phase	Single-phase
Cooling rated power	kW	2.64	3.51	5.27	7.03
Heating rated power	kW	2.92	3.81	5.57	7.33
Sound pressure level at 1 m (VL/LS/MS/HS)	dB(A)	20/24/29/36	21/25/33/39	22/28/33/43	25/30/41/47
Sound level	dB(A)	55	55	58	63
Airflow (LS/MS/HS)	m ³ /h	303/362/483	395/477/584	420/500/730	640/830/1020
Dehumidification	l/h	0.90	1.20	1.80	2.40
Outline dimensions (WxHxD)	mm	802x297x189	802x297x189	965x319x215	1080x335x226
Package dimensions (WxHxD)	mm	875x380x285	875x380x285	1045x410x305	1155x320x415
Net weight/Gross weight	kg	8.6/11.3	8.6/11.3	10.9/12.5	13.7/17.5
Panel part number - Silver Grey		7ACTL0551	7ACTL0551	7ACTL0552	7ACTL0553
Panel part number - Champagne Beige		7ACTL0543	7ACTL0543	7ACTL0544	7ACTL0545
Panel part number - Passion Red		7ACTL0547	7ACTL0547	7ACTL0548	7ACTL0549

PIPE LINE

Suction pipe diameter	inches	3/8"	3/8"	1/2"	5/8"
Liquid pipe diameter	inches	1/4"	1/4"	1/4"	3/8"



High wall HDLA
22/25/35/50/70

		NEW				
INDOOR UNIT		HDLA-022N-09M25	HDLA-025N-09M25	HDLA-035N-09M25	HDLA-050N-09M25	HDLA-070N-09M25
Part number		7SP023249	7SP023250	7SP023251	7SP023252	7SP023253
Phase		Single-phase	Single-phase	Single-phase	Single-phase	Single-phase
Cooling rated power	kW	2.05	2.64	3.52	5.28	7.03
Heating rated power	kW	2.34	2.93	3.81	5.57	7.33
Sound pressure level at 1 m (VL/LS/MS/HS)	dB(A)	21/26/30/40	21/25/32/38.5	21/25/34.5/40.5	20/26/36/42.5	36/40.5/45
Sound level	dB(A)	54	54	55	56	59
Airflow (LS/MS/HS)	m ³ /h	325/360/460	325/360/466	325/430/540	540/680/840	662/817/980
Dehumidification	l/h	0.7	0.9	1.2	1.8	2.4
Outline dimensions (WxHxD)	mm	805x285x194	805x285x194	805x285x194	957x302x213	1040x327x220
Package dimensions (WxHxD)	mm	870x365x270	870x365x270	870x365x270	1035x385x295	1120x315x405
Net weight/Gross weight	kg	7.5/9.8	7.5/9.8	7.6/9.9	10.0/12.1	12.3/15.8

PIPE LINE

Suction pipe diameter	inches	3/8"	3/8"	3/8"	1/2"	5/8"
Liquid pipe diameter	inches	1/4"	1/4"	1/4"	1/4"	3/8"



Console
XDMX 35/50

INDOOR UNIT		XDMX-035N-09M25	XDMX-050N-09M25
Part number		7SP071435	7SP071436
Phase		Single-phase	Single-phase
Cooling rated power	kW	3.52	4.98
Heating rated power	kW	3.81	5.28
Sound pressure level at 1 m (LS/MS/HS)	dB(A)	27/34/37	32/38/41
Sound level	dB(A)	54	55
Airflow (LS/MS/HS)	m ³ /h	490/580/650	600/690/780
Dehumidification	l/h	1.2	1.8
Outline dimensions (WxHxD)	mm	794x621x200	794x621x200
Package dimensions (WxHxD)	mm	865x280x719	865x280x719
Net weight/Gross weight	kg	14.9/18.8	14.9/18.8

PIPE LINE

Suction pipe diameter	inches	3/8"	1/2"
Liquid pipe diameter	inches	1/4"	1/4"



Floor ceiling
FDMX 50/70

INDOOR UNIT		FDMX-050N-09M25	FDMX-070N-09M25
Part number		7SP012300	7SP012301
Phase		Single-phase	Single-phase
Cooling rated power	kW	5.28	7.03
Heating rated power	kW	5.57	7.62
Sound pressure level at 1 m (LS/MS/HS)	dB(A)	37/41/44	43/47/51
Sound level	dB(A)	59	55
Airflow (LS/MS/HS)	m ³ /h	723/839/958	853/1023/1192
Dehumidification	l/h	1.80	2.40
Outline dimensions (WxHxD)	mm	1068x675x235	1068x675x235
Package dimensions (WxHxD)	mm	1145x755x318	1145x755x318
Net weight/Gross weight	kg	28/33.4	28/33.2
PIPE LINE			
Suction pipe diameter	inches	1/2"	5/8"
Liquid pipe diameter	inches	1/4"	3/8"



Ducted DDMX*
22/35/50/70

		NEW			
INDOOR UNIT		DDMX-022N-09M25	DDMX-035N-09M25	DDMX-050N-09M25	DDMX-070N-09M25
Part number		7SP033069	7SP033070	7SP033071	7SP033072
Phase		Single-phase	Single-phase	Single-phase	Single-phase
Cooling rated power	kW	2.05	3.52	5.28	7.03
Heating rated power	kW	2.34	3.81	5.57	7.62
Sound pressure level at 1 m (VL/LS/MS/HS)	dB(A)	23/27/34/40	23/29/30/34	23/29/30/34	27/37/42/40
Sound level	dB(A)	58	58	58	62
Airflow (LS/MS/HS)	m ³ /h	230/340/500	300/480/600	515.2/706/911	825.1/1035/1229
External static pressure (standard/max.)	Pa	25/0-40	25/0-60	25/0-100	25/0-160
Dehumidification	l/h	0.7	1.20	1.80	2.40
Outline dimensions (WxHxD)	mm	700x200x506	700x200x506	880x210x674	1100x249x774
Package dimensions (WxHxD)	mm	860x285x540	860x285x540	1070x280x725	1305x315x805
Net weight/Gross weight	kg	17.8/25.2	17.8/21.5	24.4/29.6	32.3/39.1
PIPE LINE					
Suction pipe diameter	inches	3/8"	3/8"	1/2"	5/8"
Liquid pipe diameter	inches	1/4"	1/4"	1/4"	3/8"

* In a multisplit configuration, the DDMX is not Wellzone-compatible.



Cassette CDMX
22/25/35/50/70

NEW

INDOOR UNIT		CDMX-022N-09M25	CDMX-025N-09M25	CDMX-035N-09M25	CDMX-050N-09M25	CDMX-070N-09M25
Part number		7SP042289	7SP042290	7SP042291	7SP042292	7SP042293
Phase		Single-phase	Single-phase	Single-phase	Single-phase	Single-phase
Cooling rated power	kW	2.05	2.60	3.52	5.28	7.03
Heating rated power	kW	2.35	2.90	3.81	5.57	7.62
Sound pressure level at 1 m (LS/MS/HS)	dB(A)	29/33/38	31/34/39	34/37/42	39/44/45	42/47/50
Sound level	dB(A)	53	54	57	59	59
Airflow (LS/MS/HS)	m ³ /h	400/460/500	400/504/580	389/485/569	479/584/680	992/1118/1247
Dehumidification	l/h	0.7	1.20	1.50	2.00	3.00
Outline dimensions (WxHxD)	mm	570x260x570	570x260x570	570x260x570	570x260x570	830x205x830
Package dimensions (WxHxD)	mm	662x317x662	662x317x662	662x317x662	662x317x662	910x250x910
Net weight/Gross weight	kg	14.5/17.3	14.5/17.3	16.3/20.4	16/22.1	21.6/25.4
PANEL						
Outline dimensions (WxHxD)	mm	647x50x647	647x50x647	647x50x647	647x50x647	950x55x950
Package dimensions (WxHxD)	mm	715x123x715	715x123x715	715x123x715	715x123x715	1035x90x1035
Net weight/Gross weight	kg	2.5/4.5	2.5/4.5	2.5/4.5	2.5/4.5	6/9
Panel part number		7ACVF0566	7ACVF0566	7ACVF0566	7ACVF0566	7ACVF0600
PIPE LINE						
Suction pipe diameter	inches	3/8"	3/8"	3/8"	1/2"	5/8"
Liquid pipe diameter	inches	1/4"	1/4"	1/4"	1/4"	3/8"



Compatible
WITH:

> High wall HDHC Artica
25/35/50



> High wall HDMB
Harmonia
25/35/50



White



Mirror



Grey

> High wall HDLA
22/25/35/50



> Console XDMX
35/50



> Floor ceiling
FDMX 50



> Ducted DDMX
22/35/50



> Cassette CDMX
22/25/35/50



ZDAA-2040 MULTISPLIT DUO

Indoor unit combination	COOLING										HEATING									
	Rated power (kW)		Total power (kW)			Total input power (kW)			EER	SEER/ Energy label	Rated power (kW)		Total power (kW)			Total input power (kW)			COP	SCOP/ Energy label
	Unit A	Unit B	Min.	Rated	Max.	Min.	Rated	Max.			Unit A	Unit B	Min.	Rated	Max.	Min.	Rated	Max.		
22	2.00	-	1.23	2.00	2.90	0.30	0.62	0.77	3.25	-	2.45	-	1.32	2.50	2.82	0.28	0.67	0.83	3.75	-
25	2.50	-	1.23	2.50	3.20	0.30	0.77	0.96	3.25	-	2.92	-	1.32	2.90	3.36	0.28	0.78	0.97	3.73	-
35	3.50	-	1.23	3.50	3.90	0.30	1.08	1.35	3.25	-	3.75	-	1.32	3.80	4.31	0.28	1.02	1.28	3.72	-
50	4.10	-	1.35	4.10	4.90	0.40	1.27	1.59	3.23	-	4.40	-	1.45	4.40	5.24	0.38	1.19	1.48	3.71	-
22+22	2.05	2.05	1.76	4.10	4.92	0.44	1.27	1.59	3.23	6.8/A++	2.20	2.20	1.89	4.40	5.28	0.42	1.19	1.48	3.71	4.0/A+
22+25	1.79	2.31	1.76	4.10	4.92	0.44	1.27	1.59	3.23	6.8/A++	1.93	2.48	1.89	4.40	5.28	0.42	1.19	1.48	3.71	4.0/A+
22+35	1.51	2.59	1.76	4.10	4.92	0.44	1.27	1.59	3.23	6.8/A++	1.62	2.78	1.89	4.40	5.28	0.42	1.19	1.48	3.71	4.0/A+
25+25	2.05	2.05	1.76	4.10	4.92	0.44	1.27	1.59	3.23	6.8/A++	2.20	2.20	1.89	4.40	5.28	0.42	1.19	1.48	3.71	4.0/A+
25+35	1.76	2.34	1.76	4.10	4.92	0.44	1.27	1.59	3.23	6.8/A++	1.89	2.51	1.89	4.40	5.28	0.42	1.19	1.48	3.71	4.0/A+

Based on HDMB Harmonia wall mounted combination

ZDAA-2050 MULTISPLIT DUO

Indoor unit combination	COOLING										HEATING									
	Rated power (kW)		Total power (kW)			Total input power (kW)			EER	SEER/ Energy label	Rated power (kW)		Total power (kW)			Total input power (kW)			COP	SCOP/ Energy label
	Unit A	Unit B	Min.	Rated	Max.	Min.	Rated	Max.			Unit A	Unit B	Min.	Rated	Max.	Min.	Rated	Max.		
22	2.00	-	1.43	2.00	2.90	0.35	0.60	0.75	3.35	-	2.50	-	1.56	2.50	3.03	0.32	0.67	0.83	3.75	-
25	2.50	-	1.43	2.50	3.20	0.35	0.75	0.93	3.35	-	3.00	-	1.56	3.00	3.63	0.32	0.80	1.00	3.75	-
35	3.50	-	1.43	3.50	3.90	0.35	1.08	1.29	3.25	-	3.80	-	1.56	3.80	4.60	0.32	1.00	1.20	3.81	-
50	5.00	-	1.64	5.00	5.51	0.45	1.55	1.89	3.23	-	5.20	-	1.73	5.20	5.79	0.42	1.35	1.88	3.85	-
22+22	2.65	2.65	2.12	5.30	5.62	0.54	1.64	2.05	3.23	6.1/A++	2.50	2.50	2.23	5.00	6.04	0.51	1.35	1.88	3.71	4.0/A+
22+25	2.32	2.98	2.12	5.30	5.83	0.54	1.64	2.05	3.23	6.1/A++	2.32	2.98	2.23	5.30	6.12	0.51	1.43	1.88	3.71	4.0/A+
22+35	1.95	3.35	2.12	5.30	6.41	0.54	1.64	2.05	3.23	6.1/A++	2.03	3.47	2.23	5.50	6.36	0.51	1.48	1.88	3.71	4.0/A+
22+50	1.48	3.85	2.12	5.30	6.47	0.54	1.64	2.05	3.23	6.1/A++	1.60	4.14	2.23	5.70	6.60	0.51	1.54	1.88	3.71	4.0/A+
25+25	2.65	2.65	2.12	5.3	6.41	0.54	1.64	2.05	3.23	6.3/A++	2.78	2.78	2.23	5.57	6.68	0.51	1.50	1.88	3.71	4.0/A+
25+35	2.27	3.03	2.12	5.3	6.41	0.54	1.64	2.05	3.23	6.3/A++	2.39	3.18	2.23	5.57	6.68	0.51	1.50	1.88	3.71	4.0/A+
25+50	1.77	3.53	2.12	5.3	6.47	0.54	1.64	2.05	3.23	6.3/A++	1.86	3.71	2.23	5.57	6.68	0.51	1.50	1.88	3.71	4.0/A+
35+35	2.65	2.65	2.12	5.3	6.41	0.54	1.64	2.05	3.23	6.3/A++	2.79	2.79	2.23	5.57	6.68	0.51	1.50	1.88	3.71	4.0/A+

Based on HDMB Harmonia wall mounted combination



Compatible
WITH:

> High wall HDHC Artica
25/35/50



> High wall HDMB
Harmonia
25/35/50



White



Mirror



Grey

> High wall HDLA
22/25/35/50



> Console XDMX
35/50



> Floor ceiling
FDMX 50



> Ducted DDMX
22/35/50



> Cassette CDMX
22/25/35/50



ZDAA-3080 MULTISPLIT TRIO

Indoor unit combination	COOLING											HEATING										
	Rated power (kW)			Total power (kW)			Total input power (kW)			EER	SEER/ Energy label	Rated power (kW)			Total power (kW)			Total input power (kW)			COP	SCOP/ Energy label
	Unit A	Unit B	Unit C	Min.	Rated	Max.	Min.	Rated	Max.			Unit A	Unit B	Unit C	Min.	Rated	Max.	Min.	Rated	Max.		
22	2.00	-	-	1.58	2.00	2.90	0.40	0.62	0.77	3.23	-	2.50	-	-	1.64	2.50	2.90	0.40	0.67	0.84	3.73	-
25	2.50	-	-	1.58	2.50	3.20	0.40	0.77	0.97	3.23	-	3.00	-	-	1.64	3.00	3.20	0.40	0.80	1.01	3.73	-
35	3.50	-	-	1.58	3.50	3.90	0.40	1.08	1.30	3.23	-	3.80	-	-	1.64	3.80	3.90	0.40	1.02	1.22	3.73	-
50	5.00	-	-	1.78	5.00	6.50	0.50	1.55	1.78	3.23	-	5.20	-	-	1.89	5.20	7.22	0.50	1.39	1.59	3.75	-
22+22	2.10	2.10	-	2.22	4.20	6.33	0.64	1.30	2.08	3.23	5.6/A+	2.50	2.50	-	2.30	5.00	6.56	0.57	1.35	1.87	3.71	3.8/A
22+25	2.06	2.64	-	2.22	4.70	6.73	0.64	1.46	2.20	3.23	5.6/A+	2.45	3.15	-	2.30	5.60	6.98	0.57	1.51	1.98	3.71	3.8/A
22+35	1.95	3.35	-	2.22	5.30	7.12	0.64	1.64	2.45	3.23	5.6/A+	2.21	3.79	-	2.30	6.00	7.39	0.57	1.62	2.20	3.71	3.8/A
22+50	1.82	4.68	-	2.22	6.50	7.91	0.64	2.01	2.69	3.23	5.6/A+	1.96	5.04	-	2.30	7.00	8.21	0.57	1.89	2.42	3.71	3.8/A
25+25	2.65	2.65	-	2.22	5.30	7.12	0.64	1.64	2.45	3.23	5.6/A+	3.00	3.00	-	2.30	6.00	7.39	0.57	1.62	2.20	3.71	3.8/A
25+35	2.57	3.43	-	2.22	6.00	7.52	0.64	1.86	2.57	3.23	5.6/A+	2.70	3.60	-	2.30	6.30	7.80	0.57	1.70	2.31	3.71	3.8/A
25+50	2.27	4.53	-	2.22	6.80	7.91	0.64	2.11	2.69	3.23	5.6/A+	2.33	4.67	-	2.30	7.00	8.21	0.57	1.89	2.42	3.71	3.8/A
35+35	3.15	3.15	-	2.22	6.30	7.68	0.64	1.95	2.65	3.23	5.6/A+	3.25	3.25	-	2.30	6.50	7.96	0.57	1.75	2.38	3.71	3.8/A
35+50	2.72	4.08	-	2.22	6.80	7.91	0.64	2.11	2.69	3.23	5.6/A+	2.80	4.20	-	2.30	7.00	8.21	0.57	1.89	2.42	3.71	3.8/A
22+22+22	2.43	2.43	2.43	2.77	7.30	8.70	0.76	2.26	2.92	3.23	6.1/A++	2.73	2.73	2.73	2.87	8.20	9.85	0.68	2.21	2.75	3.71	4.0/A+
22+22+25	2.25	2.25	2.90	2.77	7.40	8.70	0.76	2.29	2.92	3.23	6.1/A++	2.50	2.50	3.21	2.87	8.20	9.85	0.68	2.21	2.75	3.71	4.0/A+
22+22+35	2.13	2.13	3.65	2.77	7.90	8.70	0.76	2.45	2.92	3.23	6.1/A++	2.21	2.21	3.78	2.87	8.20	9.85	0.68	2.21	2.75	3.71	4.0/A+
22+22+50	1.73	1.73	4.44	2.77	7.90	8.70	0.76	2.45	2.92	3.23	6.1/A++	1.79	1.79	4.61	2.87	8.20	9.85	0.68	2.21	2.75	3.71	4.0/A+
22+25+25	2.13	2.74	2.74	2.77	7.60	8.70	0.76	2.35	2.92	3.23	6.1/A++	2.30	2.95	2.95	2.87	8.20	9.85	0.68	2.21	2.75	3.71	4.0/A+
22+25+35	1.98	2.54	3.39	2.77	7.90	8.70	0.76	2.45	2.92	3.23	6.1/A++	2.05	2.64	3.51	2.87	8.20	9.85	0.68	2.21	2.75	3.71	4.0/A+
22+25+50	1.63	2.09	4.18	2.77	7.90	8.70	0.76	2.45	2.92	3.23	6.1/A++	1.69	2.17	4.34	2.87	8.20	9.85	0.68	2.21	2.75	3.71	4.0/A+
22+35+35	1.78	3.06	3.06	2.77	7.90	8.70	0.76	2.45	2.92	3.23	6.1/A++	1.85	3.17	3.17	2.87	8.20	9.85	0.68	2.21	2.75	3.71	4.0/A+
25+25+25	2.64	2.64	2.64	2.77	7.91	8.70	0.76	2.45	2.92	3.23	6.3/A++	2.74	2.74	2.74	2.87	8.21	9.85	0.68	2.20	2.75	3.73	4.0/A+
25+25+35	2.37	2.37	3.16	2.77	7.90	8.70	0.76	2.45	2.92	3.23	6.3/A++	2.46	2.46	3.28	2.87	8.20	9.85	0.68	2.20	2.75	3.73	4.0/A+
25+35+35	2.15	2.87	2.87	2.77	7.90	8.70	0.76	2.45	2.92	3.23	6.3/A++	2.24	2.98	2.98	2.87	8.20	9.85	0.68	2.20	2.75	3.73	4.0/A+
35+35+35	2.63	2.63	2.63	2.77	7.90	8.70	0.76	2.45	2.92	3.23	6.3/A++	2.73	2.73	2.73	2.87	8.20	9.85	0.68	2.20	2.75	3.73	4.0/A+

Based on HDMB Harmonia wall mounted combination

Optimum combinations



Compatible
WITH:

> High wall HDHC Artica
25/35/50/70



> High wall HDMB
Harmonia
25/35/50/70



White



Mirror



Grey

> High wall HDLA
22/25/35/50/70



> Console XDMX
35/50



> Floor ceiling
FDMX 50/70



> Ducted DDMX
22/35/50/70



> Cassette CDMX
22/25/35/50/70



ZDAA-4090 MULTISPLIT QUATTRO

Indoor unit combination	COOLING											HEATING												
	Rated power (kW)				Total power (kW)			Total input power (kW)			EER	SEER/ Energy label	Rated power (kW)				Total power (kW)			Total input power (kW)			COP	SCOP/ Energy label
	Unit A	Unit B	Unit C	Unit D	Min.	Rated	Max.	Min.	Rated	Max.			Unit A	Unit B	Unit C	Unit D	Min.	Rated	Max.	Min.	Rated	Max.		
22	2.00	-	-	-	1.58	2.00	2.90	0.45	0.61	0.76	3.28	-	2.50	-	-	-	1.58	2.50	2.90	0.45	0.67	0.84	3.71	-
25	2.50	-	-	-	1.58	2.50	3.20	0.45	0.76	0.95	3.28	-	3.00	-	-	-	1.58	3.00	3.20	0.45	0.81	1.01	3.71	-
35	3.50	-	-	-	1.58	3.50	3.90	0.45	1.07	1.28	3.28	-	3.80	-	-	-	1.58	3.80	3.90	0.45	1.02	1.23	3.71	-
50	5.00	-	-	-	1.79	5.00	6.50	0.58	1.52	1.75	3.28	-	5.20	-	-	-	1.79	5.20	7.00	0.55	1.40	1.61	3.71	-
70	7.00	-	-	-	2.21	7.00	8.00	0.62	2.13	2.45	3.28	-	7.20	-	-	-	1.79	7.20	8.00	0.58	1.94	2.23	3.71	-
22+22	2.10	2.10	-	-	2.21	4.20	6.30	0.62	1.28	2.11	3.28	51/A	2.50	2.50	-	-	2.22	5.00	6.33	0.54	1.35	1.85	3.71	3.4/A
22+25	2.06	2.64	-	-	2.21	4.70	6.51	0.62	1.43	2.28	3.28	51/A	2.45	3.15	-	-	2.22	5.60	6.54	0.54	1.51	1.99	3.71	3.4/A
22+35	2.03	3.47	-	-	2.21	5.50	6.83	0.62	1.68	2.44	3.28	51/A	2.21	3.79	-	-	2.22	6.00	6.86	0.54	1.62	2.13	3.71	3.4/A
22+50	1.96	5.04	-	-	2.21	7.00	8.40	0.62	2.13	2.86	3.28	52/A	2.24	5.76	-	-	2.22	8.00	8.44	0.54	2.16	2.50	3.71	3.4/A
22+70	2.03	6.97	-	-	2.21	9.00	9.45	0.62	2.74	3.06	3.28	52/A	2.17	7.43	-	-	2.22	9.60	10.23	0.54	2.59	2.67	3.71	3.4/A
25+25	2.65	2.65	-	-	2.21	5.30	6.83	0.62	1.62	2.44	3.28	52/A	3.00	3.00	-	-	2.22	6.00	6.86	0.54	1.62	2.13	3.71	3.4/A
25+35	2.57	3.43	-	-	2.21	6.00	7.35	0.62	1.83	2.60	3.28	52/A	3.00	4.00	-	-	2.22	7.00	7.39	0.54	1.89	2.27	3.71	3.4/A
25+50	2.50	5.00	-	-	2.21	7.50	9.45	0.62	2.29	2.93	3.28	52/A	2.93	5.87	-	-	2.22	8.80	9.50	0.54	2.37	2.56	3.71	3.4/A
25+70	2.59	6.91	-	-	2.21	9.50	9.98	0.62	2.90	3.12	3.28	52/A	2.67	7.13	-	-	2.22	9.80	10.13	0.54	2.64	2.70	3.71	3.4/A
35+35	3.50	3.50	-	-	2.21	7.00	7.88	0.62	2.13	2.76	3.28	52/A	3.75	3.75	-	-	2.22	7.50	7.91	0.54	2.02	2.42	3.71	3.4/A
35+50	3.40	5.10	-	-	2.21	8.50	9.98	0.62	2.59	2.93	3.28	52/A	3.76	5.64	-	-	2.22	9.40	10.02	0.54	2.53	2.56	3.71	3.4/A
50+70	3.33	6.67	-	-	2.21	10.00	10.50	0.62	3.09	3.19	3.24	52/A	3.33	6.67	-	-	2.22	10.00	10.34	0.54	2.70	2.79	3.71	3.4/A
50+50	5.00	5.00	-	-	2.21	10.00	10.50	0.62	3.09	3.25	3.24	52/A	5.05	5.05	-	-	2.22	10.10	10.55	0.54	2.72	2.84	3.71	3.5/A
22+22+22	2.00	2.00	2.00	-	2.84	6.00	7.35	0.78	1.80	2.93	3.33	56/A+	2.50	2.50	2.50	-	2.85	7.50	7.39	0.68	2.02	2.56	3.71	3.6/A
22+22+25	1.98	1.98	2.54	-	2.84	6.50	7.88	0.78	1.98	3.09	3.28	56/A+	2.37	2.37	3.05	-	2.85	7.80	7.91	0.68	2.10	2.70	3.71	3.6/A
22+22+35	2.02	2.02	3.46	-	2.84	7.50	8.93	0.78	2.29	3.25	3.28	56/A+	2.29	2.29	3.92	-	2.85	8.50	8.97	0.68	2.29	2.84	3.71	3.6/A
22+22+50	1.97	1.97	5.06	-	2.84	9.00	11.55	0.78	2.74	3.58	3.28	58/A+	2.34	2.34	6.02	-	2.85	10.70	11.61	0.68	2.88	3.13	3.71	3.6/A
22+22+70	1.84	1.84	6.32	-	2.84	10.00	11.55	0.78	3.09	3.58	3.24	58/A+	1.97	1.97	6.76	-	2.85	10.70	11.61	0.68	2.88	3.13	3.71	3.6/A
22+25+25	1.96	2.52	2.52	-	2.84	7.00	8.93	0.78	2.13	3.25	3.28	58/A+	2.38	3.06	3.06	-	2.85	8.50	8.97	0.68	2.29	2.84	3.71	3.6/A
22+25+35	2.00	2.57	3.43	-	2.84	8.00	9.98	0.78	2.44	3.41	3.28	58/A+	2.50	3.21	4.29	-	2.85	10.00	10.02	0.68	2.70	2.99	3.71	3.6/A
22+25+50	1.96	2.51	5.03	-	2.84	9.50	11.55	0.78	2.93	3.58	3.24	58/A+	2.20	2.83	5.66	-	2.85	10.70	11.61	0.68	2.88	3.13	3.71	3.6/A

Indoor unit combination	COOLING											HEATING												
	Rated power (kW)				Total power (kW)			Total input power (kW)			EER	SEER/ Energy label	Rated power (kW)				Total power (kW)			Total input power (kW)			COP	SCOP/ Energy label
	Unit A	Unit B	Unit C	Unit D	Min.	Rated	Max.	Min.	Rated	Max.			Unit A	Unit B	Unit C	Unit D	Min.	Rated	Max.	Min.	Rated	Max.		
22+25+70	1.75	2.25	6.00	-	2.84	10.00	11.55	0.78	3.09	3.58	3.24	5.8/A+	1.87	2.41	6.42	-	2.85	10.70	11.61	0.68	2.88	3.13	3.71	3.6/A
22+35+35	2.03	3.48	3.48	-	2.84	9.00	10.50	0.78	2.78	3.41	3.24	5.8/A+	2.28	3.91	3.91	-	2.85	10.10	10.55	0.68	2.72	2.99	3.71	3.6/A
22+35+50	1.89	3.24	4.86	-	2.84	10.00	11.55	0.78	3.09	3.58	3.24	5.8/A+	2.02	3.47	5.21	-	2.85	10.70	11.61	0.68	2.88	3.13	3.71	3.6/A
22+35+70	1.63	2.79	5.58	-	2.84	10.00	11.55	0.78	3.09	3.58	3.24	5.8/A+	1.74	2.99	5.97	-	2.85	10.70	11.61	0.68	2.88	3.13	3.71	3.6/A
22+50+50	1.63	4.19	4.19	-	2.84	10.00	11.55	0.78	3.09	3.58	3.24	5.8/A+	1.74	4.48	4.48	-	2.85	10.70	11.61	0.68	2.88	3.13	3.71	3.6/A
25+25+25	2.50	2.50	2.50	-	2.84	7.50	9.98	0.78	2.31	3.41	3.24	5.8/A+	3.33	3.33	3.33	-	2.85	10.00	10.02	0.68	2.70	2.99	3.71	3.6/A
25+25+35	2.55	2.55	3.40	-	2.84	8.50	10.50	0.78	2.62	3.41	3.24	5.8/A+	3.03	3.03	4.04	-	2.85	10.10	10.55	0.68	2.72	2.99	3.71	3.6/A
25+25+50	2.50	2.50	5.00	-	2.84	10.00	11.55	0.78	3.09	3.58	3.24	5.8/A+	2.68	2.68	5.35	-	2.85	10.70	11.61	0.68	2.88	3.13	3.71	3.6/A
25+25+70	2.14	2.14	5.71	-	2.84	10.00	11.55	0.78	3.09	3.58	3.24	5.8/A+	2.29	2.29	6.11	-	2.73	10.70	11.11	0.65	2.88	2.99	3.71	3.6/A
25+35+35	2.59	3.45	3.45	-	2.84	9.50	11.55	0.78	2.93	3.58	3.24	5.8/A+	2.92	3.89	3.89	-	2.85	10.70	11.61	0.68	2.88	3.13	3.71	3.6/A
25+35+50	2.31	3.08	4.62	-	2.84	10.00	11.55	0.78	3.09	3.58	3.24	5.8/A+	2.47	3.29	4.94	-	2.85	10.70	11.61	0.68	2.88	3.13	3.71	3.6/A
25+35+70	2.00	2.67	5.33	-	2.84	10.00	11.55	0.78	3.09	3.58	3.24	5.8/A+	2.14	2.85	5.71	-	2.85	10.70	11.61	0.68	2.88	3.13	3.71	3.6/A
25+50+50	2.00	4.00	4.00	-	2.84	10.00	11.55	0.78	3.09	3.58	3.24	5.8/A+	2.14	4.28	4.28	-	2.85	10.70	11.61	0.68	2.88	3.13	3.71	3.6/A
35+35+35	3.33	3.33	3.33	-	2.84	10.00	11.55	0.78	3.09	3.58	3.24	5.8/A+	3.57	3.57	3.57	-	2.85	10.70	11.61	0.68	2.88	3.13	3.71	3.6/A
35+35+50	2.86	2.86	4.29	-	2.84	10.00	11.55	0.78	3.09	3.58	3.24	5.8/A+	3.06	3.06	4.59	-	2.85	10.70	11.61	0.68	2.88	3.13	3.71	3.6/A
35+35+70	2.50	2.50	5.00	-	2.84	10.00	11.55	0.78	3.09	3.58	3.24	5.8/A+	2.68	2.68	5.35	-	2.85	10.70	11.61	0.68	2.88	3.13	3.71	3.6/A
35+50+50	2.50	3.75	3.75	-	2.84	10.00	11.55	0.78	3.09	3.58	3.24	5.8/A+	2.68	4.01	4.01	-	2.85	10.70	11.61	0.68	2.88	3.13	3.71	3.6/A
22+22+22+22	2.05	2.05	2.05	2.05	3.68	8.20	10.50	0.88	2.29	3.25	3.58	6.1/A++	2.50	2.50	2.50	2.50	3.69	10.00	10.55	0.77	2.70	2.84	3.71	3.8/A
22+22+22+25	1.98	1.98	1.98	2.55	3.68	8.50	11.55	0.88	2.47	3.41	3.44	6.1/A++	2.36	2.36	2.36	3.03	3.69	10.10	11.08	0.77	2.72	2.99	3.71	3.8/A
22+22+22+35	2.02	2.02	2.02	3.45	3.68	9.50	12.60	0.88	2.86	3.84	3.32	6.1/A++	2.31	2.31	2.31	3.96	3.69	10.90	11.61	0.77	2.94	3.13	3.71	3.8/A
22+22+22+50	1.87	1.87	1.87	4.80	3.68	10.40	13.65	0.88	3.22	3.97	3.23	6.2/A++	1.99	1.99	1.99	5.12	3.69	11.10	12.66	0.77	2.99	3.70	3.71	3.8/A
22+22+22+70	1.65	1.65	1.65	5.65	3.68	10.60	13.65	0.88	3.28	3.97	3.23	6.2/A++	1.73	1.73	1.73	5.92	3.69	11.10	12.66	0.77	2.99	3.70	3.71	3.8/A
22+22+25+25	1.97	1.97	2.53	2.53	3.68	9.00	12.60	0.88	2.71	3.84	3.32	6.2/A++	2.38	2.38	3.07	3.07	3.69	10.90	11.61	0.77	2.94	3.13	3.71	3.8/A
22+22+25+35	2.00	2.00	2.57	3.43	3.68	10.00	13.13	0.88	3.09	3.90	3.24	6.2/A++	2.22	2.22	2.85	3.81	3.69	11.10	12.13	0.77	2.99	3.41	3.71	3.8/A
22+22+25+50	1.81	1.81	2.33	4.65	3.68	10.60	13.65	0.88	3.28	3.97	3.23	6.2/A++	1.90	1.90	2.44	4.87	3.69	11.10	12.66	0.77	2.99	3.70	3.71	3.8/A
22+22+25+70	1.58	1.58	2.03	5.41	3.68	10.60	13.65	0.88	3.28	3.97	3.23	6.2/A++	1.65	1.65	2.13	5.67	3.69	11.10	12.66	0.77	2.99	3.70	3.71	3.8/A
22+22+35+35	1.95	1.95	3.35	3.35	3.68	10.60	13.65	0.88	3.28	3.97	3.23	6.2/A++	2.04	2.04	3.51	3.51	3.69	11.10	12.66	0.77	2.99	3.70	3.71	3.8/A
22+22+35+50	1.69	1.69	2.89	4.34	3.68	10.60	13.65	0.88	3.28	3.97	3.23	6.2/A++	1.77	1.77	3.03	4.54	3.69	11.10	12.66	0.77	2.99	3.70	3.71	3.8/A
22+22+50+50	1.48	1.48	3.82	3.82	3.68	10.60	13.65	0.88	3.28	3.97	3.23	6.2/A++	1.55	1.55	4.00	4.00	3.69	11.10	12.66	0.77	2.99	3.70	3.71	3.8/A
22+25+25+25	1.96	2.51	2.51	2.51	3.68	9.50	13.13	0.88	2.92	3.84	3.25	6.2/A++	2.29	2.94	2.94	2.94	3.69	11.10	12.13	0.77	2.99	3.27	3.71	3.8/A
22+25+25+35	2.01	2.58	2.58	3.44	3.68	10.60	13.65	0.88	3.28	3.97	3.23	6.2/A++	2.10	2.70	2.70	3.60	3.69	11.10	12.66	0.77	2.99	3.70	3.71	3.8/A
22+25+25+50	1.73	2.22	2.22	4.44	3.68	10.60	13.65	0.88	3.28	3.97	3.23	6.2/A++	1.81	2.32	2.32	4.65	3.69	11.10	12.66	0.77	2.99	3.70	3.71	3.8/A
22+25+25+70	1.51	1.95	1.95	5.19	3.68	10.60	13.65	0.88	3.28	3.97	3.23	6.2/A++	1.59	2.04	2.04	5.44	3.69	11.10	12.66	0.77	2.99	3.70	3.71	3.8/A
22+25+50+50	1.86	2.39	3.18	3.18	3.68	10.60	13.65	0.88	3.28	3.97	3.23	6.2/A++	1.94	2.50	3.33	3.33	3.69	11.10	12.66	0.77	2.99	3.70	3.71	3.8/A
22+25+35+50	1.61	2.07	2.77	4.15	3.68	10.60	13.65	0.88	3.28	3.97	3.23	6.2/A++	1.69	2.17	2.90	4.34	3.69	11.10	12.66	0.77	2.99	3.70	3.71	3.8/A
22+25+50+50	1.43	1.83	3.67	3.67	3.68	10.60	13.65	0.88	3.28	3.97	3.23	6.2/A++	1.49	1.92	3.84	3.84	3.69	11.10	12.66	0.77	2.99	3.70	3.71	3.8/A
22+35+35+35	1.73	2.96	2.96	2.96	3.68	10.60	13.65	0.88	3.28	3.97	3.23	6.2/A++	1.81	3.10	3.10	3.10	3.69	11.10	12.66	0.77	2.99	3.70	3.71	3.8/A
22+35+35+50	1.51	2.60	2.60	3.89	3.68	10.60	13.65	0.88	3.28	3.97	3.23	6.2/A++	1.59	2.72	2.72	4.08	3.69	11.10	12.66	0.77	2.99	3.70	3.71	3.8/A
25+25+25+25	2.63	2.63	2.63	2.63	3.68	10.50	13.65	0.88	3.25	3.97	3.23	6.3/A++	2.64	2.64	2.64	2.64	3.69	10.55	12.66	0.77	2.84	3.70	3.71	4.0/A+
25+25+25+35	2.42	2.42	2.42	3.23	3.68	10.50	13.65	0.88	3.25	3.97	3.23	6.3/A++	2.56	2.56	2.56	3.42	3.69	11.10	12.66	0.77	2.99	3.70	3.71	4.0/A+
25+25+25+50	2.10	2.10	2.10	4.20	3.68	10.50	13.65	0.88	3.25	3.97	3.23	6.3/A++	2.22	2.22	2.22	4.44	3.69	11.10	12.66	0.77	2.99	3.70	3.71	4.0/A+
25+25+25+70	2.25	2.25	3.00	3.00	3.68	10.50	13.65	0.88	3.25	3.97	3.23	6.3/A++	2.38	2.38	3.17	3.17	3.69	11.10	12.66	0.77	2.99	3.70	3.71	4.0/A+
25+25+35+50	1.97	1.97	2.63	3.94	3.68	10.50	13.65	0.88	3.25	3.97	3.23	6.3/A++	2.08	2.08	2.78	4.16	3.69	11.10	12.66	0.77	2.99	3.70	3.71	4.0/A+
25+35+35+35	2.10	2.80	2.80	2.80	3.68	10.50	13.65	0.88	3.25	3.97	3.23	6.3/A++	2.22	2.96	2.96	2.96	3.69	11.10	12.66	0.77	2.99	3.70	3.71	4.0/A+
25+35+35+50	1.85	2.47	2.47	3.71	3.68	10.50	13.65	0.88	3.25	3.97	3.23	6.3/A++	1.96	2.61	2.61	3.92	3.69	11.10	12.66	0.77	2.99	3.70	3.71	4.0/A+
35+35+35+35	2.63	2.63	2.63	2.63	3.68	10.50	13.65	0.88	3.25	3.97	3.23	6.3/A++	2.78	2.78	2.78	2.78	3.69	11.10	12.66	0.77	2.99	3.70	3.71	4.0/A+

Based on HDMB Harmonia wall mounted combination

Optimum combinations

DC Inverter
Reversible

ZDAA

Combination capacities



Compatible
WITH:

> High wall HDHC Artica
25/35/50/70



> High wall HDMB
Harmonia
25/35/50/70



White



Mirror

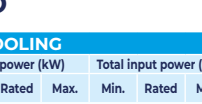

Grey

> High wall HDLA
22/25/35/50/70



> Console XDMX
35/50



> Floor ceiling
FDMX 50/70



> Ducted DDMX
22/35/50/70



> Cassette CDMX
22/25/35/50/70



ZDAA-5130 MULTISPLIT CINCO

Indoor unit combination	COOLING													HEATING												
	Rated power (kW)					Total power (kW)			Total input power (kW)			EER	SEER/ Energy label	Rated power (kW)					Total power (kW)			Total input power (kW)			COP	SCOP/ Energy label
	Unit A	Unit B	Unit C	Unit E	Unit D	Min.	Rated	Max.	Min.	Rated	Max.			Unit A	Unit B	Unit C	Unit D	Unit E	Min.	Rated	Max.	Min.	Rated	Max.		
22	2.00	-	-	-	-	1.66	2.00	2.90	0.45	1.02	1.28	1.96	-	2.50	-	-	-	-	1.66	2.50	2.90	0.45	0.67	0.83	3.75	-
25	2.50	-	-	-	-	1.66	2.50	3.20	0.45	1.28	1.60	1.96	-	3.00	-	-	-	-	1.66	3.00	3.20	0.45	0.80	1.00	3.75	-
35	3.50	-	-	-	-	1.66	3.50	3.90	0.45	1.79	2.15	1.96	-	3.80	-	-	-	-	1.66	3.80	3.90	0.45	1.01	1.22	3.75	-
50	5.00	-	-	-	-	1.85	5.00	6.50	0.58	1.98	2.28	2.52	-	5.20	-	-	-	-	1.85	5.20	7.00	0.58	1.38	1.59	3.76	-
70	7.00	-	-	-	-	2.09	7.00	8.20	0.70	2.30	2.42	3.04	-	7.20	-	-	-	-	2.09	7.20	8.50	0.70	1.90	2.00	3.78	-
22+22	2.10	2.10	-	-	-	2.34	4.20	7.38	0.65	1.49	2.21	2.81	51/A	2.50	2.50	-	-	-	2.34	5.00	7.39	0.56	1.32	1.92	3.80	3.0/C
22+25	2.06	2.64	-	-	-	2.34	4.70	7.63	0.65	1.67	2.36	2.81	51/A	2.45	3.15	-	-	-	2.34	5.60	7.63	0.56	1.47	2.06	3.80	3.0/C
22+35	2.03	3.47	-	-	-	2.34	5.50	8.00	0.65	1.95	2.55	2.81	51/A	2.21	3.79	-	-	-	2.34	6.00	8.00	0.56	1.58	2.22	3.80	3.0/C
22+50	1.96	5.04	-	-	-	2.34	7.00	9.84	0.65	2.49	2.70	2.81	51/A	2.24	5.76	-	-	-	2.34	8.00	9.85	0.56	2.11	2.36	3.80	3.0/C
22+70	2.05	7.05	-	-	-	2.34	9.10	11.69	0.65	3.23	3.05	2.81	51/A	2.21	7.59	-	-	-	2.34	9.80	11.69	0.56	2.58	2.65	3.80	3.0/C
25+25	2.65	2.65	-	-	-	2.34	5.30	8.00	0.65	1.88	2.55	2.81	51/A	3.00	3.00	-	-	-	2.34	6.00	8.00	0.56	1.58	2.22	3.80	3.0/C
25+35	2.57	3.43	-	-	-	2.34	6.00	8.61	0.65	2.13	2.59	2.81	51/A	2.91	3.89	-	-	-	2.34	6.80	8.62	0.56	1.79	2.26	3.80	3.0/C
25+50	2.50	5.00	-	-	-	2.34	7.50	11.07	0.65	2.66	2.86	2.81	51/A	2.93	5.87	-	-	-	2.34	8.80	11.08	0.56	2.32	2.49	3.80	3.0/C
25+70	2.65	7.05	-	-	-	2.34	9.70	12.30	0.65	3.45	3.24	2.81	51/A	2.78	7.42	-	-	-	2.34	10.20	12.31	0.56	2.68	2.82	3.80	3.0/C
35+35	3.50	3.50	-	-	-	2.34	7.00	9.23	0.65	2.49	2.70	2.81	51/A	3.75	3.75	-	-	-	2.34	7.50	9.23	0.56	1.97	2.36	3.80	3.0/C
35+50	3.40	5.10	-	-	-	2.34	8.50	11.69	0.65	3.02	3.12	2.81	51/A	3.76	5.64	-	-	-	2.34	9.40	11.69	0.56	2.47	2.72	3.80	3.0/C
35+70	3.33	6.67	-	-	-	2.34	10.00	12.30	0.65	3.55	3.43	2.81	51/A	3.50	7.00	-	-	-	2.34	10.50	12.31	0.56	2.76	2.99	3.80	3.0/C
50+50	5.25	5.25	-	-	-	2.34	10.50	12.30	0.65	3.73	3.43	2.81	51/A	5.50	5.50	-	-	-	2.34	11.00	12.31	0.56	2.89	2.99	3.80	3.0/C
50+70	4.93	6.57	-	-	-	2.34	11.50	12.50	0.65	3.88	3.43	2.96	51/A	4.93	6.57	-	-	-	2.34	11.50	12.51	0.56	3.01	2.99	3.82	3.0/C
22+22+22	2.00	2.00	2.00	-	-	2.89	6.00	7.38	0.80	1.73	3.05	3.48	5.3/A	2.50	2.50	2.50	-	-	2.89	7.50	8.62	0.70	1.95	2.65	3.85	3.2/B
22+22+25	1.98	1.98	2.54	-	-	2.89	6.50	8.61	0.80	1.87	3.24	3.48	5.3/A	2.37	2.37	3.05	-	-	2.89	7.80	9.23	0.70	2.03	2.82	3.85	3.2/B
22+22+35	2.02	2.02	3.46	-	-	2.89	7.50	9.23	0.80	2.16	3.43	3.48	5.3/A	2.29	2.29	3.92	-	-	2.89	8.50	9.85	0.70	2.21	2.99	3.85	3.2/B
22+22+50	1.97	1.97	5.06	-	-	2.89	9.00	11.07	0.80	2.59	3.62	3.48	5.3/A	2.52	2.52	6.47	-	-	2.89	11.50	12.31	0.70	2.99	3.15	3.85	3.2/B
22+22+70	2.03	2.03	6.95	-	-	2.89	11.00	12.92	0.80	3.16	3.81	3.48	5.3/A	2.21	2.21	7.58	-	-	2.89	12.00	12.92	0.70	3.12	3.32	3.85	3.2/B
22+25+25	1.96	2.52	2.52	-	-	2.89	7.00	9.23	0.80	2.01	3.35	3.48	5.3/A	2.38	3.06	3.06	-	-	2.89	8.50	9.85	0.70	2.21	2.92	3.85	3.2/B
22+25+35	2.00	2.57	3.43	-	-	2.89	8.00	10.46	0.80	2.30	3.50	3.48	5.3/A	2.50	3.21	4.29	-	-	2.89	10.00	12.31	0.70	2.60	3.05	3.85	3.2/B
22+25+50	1.96	2.51	5.03	-	-	2.89	9.50	11.07	0.80	2.73	3.73	3.48	5.3/A	2.37	3.04	6.09	-	-	2.89	11.50	12.31	0.70	2.99	3.25	3.85	3.2/B
22+25+70	2.01	2.59	6.90	-	-	2.89	11.50	12.92	0.80	3.31	3.96	3.48	5.3/A	2.10	2.70	7.20	-	-	2.89	12.00	12.92	0.70	3.12	3.45	3.85	3.2/B
22+35+35	2.03	3.48	3.48	-	-	2.89	9.00	11.07	0.80	2.59	3.62	3.48	5.3/A	2.48	4.26	4.26	-	-	2.89	11.00	12.31	0.70	2.86	3.15	3.85	3.2/B
22+35+50	1.99	3.41	5.11	-	-	2.89	10.50	12.30	0.80	3.02	3.81	3.48	5.3/A	2.18	3.73	5.59	-	-	2.89	11.50	12.31	0.70	2.99	3.32	3.85	3.2/B
22+35+70	1.87	3.21	6.42	-	-	2.89	11.50	12.92	0.80	3.31	3.96	3.48	5.3/A	1.95	3.35	6.70	-	-	2.89	12.00	12.92	0.70	3.12	3.45	3.85	3.2/B
22+50+50	1.87	4.81	4.81	-	-	2.89	11.50	12.92	0.80	3.31	3.96	3.48	5.3/A	1.95	5.02	5.02	-	-	2.89	12.00	12.92	0.70	3.12	3.45	3.85	3.2/B
25+25+25	2.67	2.67	2.67	-	-	2.89	8.00	10.46	0.80	2.30	3.81	3.48	5.3/A	3.33	3.33	3.33	-	-	2.89	10.00	12.31	0.70	2.60	3.32	3.85	3.2/B
25+25+35	2.70	2.70	3.60	-	-	2.89	9.00	12.92	0.80	2.59	3.62	3.48	5.3/A	3.30	3.30	4.40	-	-	2.89	11.00	12.31	0.70	2.86	3.15	3.85	3.2/B
25+25+50	2.63	2.63	5.25	-	-	2.89	10.50	12.30	0.80	3.02	3.81	3.48	5.3/A	2.88	2.88	5.75	-	-	2.89	11.50	12.31	0.70	2.99	3.32	3.85	3.2/B
25+25+70	2.46	2.46	6.57	-	-	2.89	11.50	12.92	0.80	3.31	3.96	3.48	5.3/A	2.57	2.57	6.86	-	-	2.89	12.00	12.92	0.70	3.12	3.45	3.85	3.2/B
25+35+35	2.45	3.27	3.27	-	-	2.89	9.00	11.07	0.80	2.59	3.62	3.48	5.3/A	3.14	4.18	4.18	-	-	2.89	11.50	12.31	0.70	2.99	3.15	3.85	3.2/B
25+35+50	2.54	3.38	5.08	-	-	2.89	11.00	11.69	0.80	3.16	3.81	3.48	5.3/A	2.77	3.69	5.54	-	-	2.89	12.00	12.92	0.70	3.12	3.32	3.85	3.2/B
25+35+70	2.30	3.07	6.13	-	-	2.89	11.50	12.92	0.80	3.31	3.96	3.48	5.3/A	2.40	3.20	6.40	-	-	2.89	12.00	12.92	0.70	3.12	3.45	3.85	3.2/B
25+50+50	2.40	4.80	4.80	-	-	2.89	12.00	12.92	0.80	3.45	3.96	3.48	5.3/A	2.40	4.80	4.80	-	-	2.89	12.00	12.92	0.70	3.12	3.45	3.85	3.2/B
35+35+35	3.17	3.17	3.17	-	-	2.89	9.50	11.07	0.80	2.73	3.73	3.48	5.3/A	3.83	3.83	3.83	-	-	2.89	11.50	12.31	0.70	2.99	3.25	3.85	3.2/B
35+35+50	3.29	3.29	4.93	-	-	2.89	11.50	12.92	0.80	3.31	3.96	3.48	5.3/A	3.43	3.43	5.14	-	-	2.89	12.00	12.92	0.70	3.12	3.45	3.85	3.2/B
35+35+70	3.00	3.00	6.00	-	-	2.89	12.00	12.92	0.80	3.45	3.96	3.48	5.3/A	3.00	3.00	6.00	-	-	2.89	12.00	12.92	0.70	3.12	3.45	3.85	3.2/B
35+50+50	3.00	4.50	4.50	-	-	2.89	12.00	12.92	0.80	3.45	3.96	3.48	5.3/A	3.00	4.50	4.50	-	-	2.89	12.00	12.92	0.70	3.12	3.45	3.85	3.2/B
35+50+70	2.67	4.00	5.33	-	-	2.89	12.00	12.92	0.80	4.15	3.96	2.89	5.3/A	2.67	4.00	5.33	-	-	2.89	12.00	12.92	0.70	3.12	3.45	3.85	3.2/B
50+50+50	4.00	4.00	4.00	-	-	2.89	12.00	12.92	0.80	4.15	3.96	2.89	5.3/A	4.00	4.00	4.00	-	-	2.89	12.00	12.92	0.70	3.09	3.45	3.88	3.2/B
22+22+22+22	2.00	2.00	2.00	2.00	-	3.69	8.00	10.50	0.91	2.63	3.43	3.04	5.6/A+	2.50	2.50	2.50	2.50									

Indoor unit combination	COOLING													HEATING													
	Rated power (kW)					Total power (kW)			Total input power (kW)					EER	SEER/ Energy label	Rated power (kW)					Total input power (kW)					COP	SCOP/ Energy label
	Unit A	Unit B	Unit C	Unit E	Unit D	Min.	Rated	Max.	Min.	Rated	Max.	Unit A	Unit B			Unit C	Unit D	Unit E	Min.	Rated	Max.	Min.	Rated	Max.			
22+22+35+50	1.83	1.83	3.14	4.70	-	3.69	11.50	13.53	0.91	3.97	4.19	2.90	5.6/A	1.91	1.91	3.27	4.91	-	3.69	12.00	13.54	0.80	3.07	3.65	3.91	3.4/A	
22+22+35+70	1.74	1.74	2.98	5.95	-	3.69	12.40	13.53	0.91	4.29	4.38	2.89	5.6/A	1.72	1.72	2.95	5.90	-	3.69	12.30	13.54	0.80	3.15	3.82	3.91	3.4/A	
22+22+50+50	1.74	1.74	4.46	4.46	-	3.69	12.40	13.53	0.91	4.29	4.38	2.89	5.6/A	1.68	1.68	4.32	4.32	-	3.69	12.00	13.54	0.80	3.07	3.82	3.91	3.4/A	
22+22+50+70	1.55	1.55	3.99	5.31	-	3.69	12.40	13.53	0.91	4.29	4.38	2.89	5.6/A	1.54	1.54	3.95	5.27	-	3.69	12.30	13.54	0.80	3.15	3.82	3.91	3.4/A	
22+25+25+25	2.06	2.65	2.65	2.65	-	3.69	10.00	12.30	0.91	3.35	4.19	2.99	5.6/A	2.47	3.18	3.18	3.18	-	3.69	12.00	13.54	0.80	3.07	3.65	3.91	3.4/A	
22+25+25+35	1.99	2.55	2.55	3.41	-	3.69	10.50	12.90	0.91	3.55	4.19	2.96	5.6/A	2.27	2.92	2.92	3.89	-	3.69	12.00	13.54	0.80	3.07	3.65	3.91	3.4/A	
22+25+25+50	1.87	2.41	2.41	4.81	-	3.69	11.50	13.53	0.91	3.96	4.19	2.91	5.6/A	1.95	2.51	2.51	5.02	-	3.69	12.00	13.54	0.80	3.07	3.65	3.91	3.4/A	
22+25+25+70	1.77	2.28	2.28	6.07	-	3.69	12.40	13.53	0.91	4.29	4.38	2.89	5.6/A	1.76	2.26	2.26	6.02	-	3.69	12.30	13.54	0.80	3.15	3.82	3.91	3.4/A	
22+25+35+35	2.01	2.59	3.45	3.45	-	3.69	11.50	13.53	0.91	3.92	4.19	2.93	5.6/A	2.10	2.70	3.60	3.60	-	3.69	12.00	13.54	0.80	3.07	3.65	3.91	3.4/A	
22+25+35+50	1.83	2.35	3.13	4.70	-	3.69	12.00	13.53	0.91	4.15	4.38	2.89	5.6/A	1.83	2.35	3.13	4.70	-	3.69	12.00	13.54	0.80	3.07	3.82	3.91	3.4/A	
22+25+35+70	1.67	2.15	2.86	5.72	-	3.69	12.40	13.53	0.91	4.29	4.38	2.89	5.6/A	1.66	2.13	2.84	5.68	-	3.69	12.30	13.54	0.80	3.15	3.82	3.91	3.4/A	
22+25+50+50	1.67	2.15	4.29	4.29	-	3.69	12.40	13.53	0.91	4.29	4.38	2.89	5.6/A	1.62	2.08	4.15	4.15	-	3.69	12.00	13.54	0.80	3.07	3.82	3.91	3.4/A	
22+25+50+70	1.50	1.92	3.85	5.13	-	3.69	12.40	13.53	0.91	4.27	4.38	2.91	5.6/A	1.48	1.91	3.82	5.09	-	3.69	12.30	13.54	0.80	3.15	3.82	3.91	3.4/A	
22+35+35+35	1.87	3.21	3.21	3.21	-	3.69	11.50	13.53	0.91	3.96	4.19	2.91	5.6/A	1.95	3.35	3.35	3.35	-	3.69	12.00	13.54	0.80	3.07	3.65	3.91	3.4/A	
22+35+35+50	1.71	2.94	2.94	4.41	-	3.69	12.00	13.53	0.91	4.15	4.38	2.89	5.6/A	1.71	2.94	2.94	4.41	-	3.69	12.00	13.54	0.80	3.07	3.82	3.91	3.4/A	
22+35+50+50	1.58	2.71	2.71	5.41	-	3.69	12.40	13.53	0.91	4.29	4.38	2.89	5.6/A	1.57	2.68	2.68	5.37	-	3.69	12.30	13.54	0.80	3.15	3.82	3.91	3.4/A	
22+35+50+70	1.58	2.71	4.06	4.06	-	3.69	12.40	13.53	0.91	4.29	4.38	2.89	5.6/A	1.53	2.62	3.93	3.93	-	3.69	12.00	13.54	0.80	3.07	3.82	3.91	3.4/A	
25+25+25+25	2.63	2.63	2.63	2.63	-	3.69	10.50	12.92	0.91	3.54	4.19	2.97	5.6/A	3.00	3.00	3.00	3.00	-	3.69	12.00	13.54	0.80	3.07	3.65	3.91	3.4/A	
25+25+25+35	2.65	2.65	2.65	3.54	-	3.69	11.50	13.53	0.91	3.91	4.19	2.94	5.6/A	2.77	2.77	2.77	3.69	-	3.69	12.00	13.54	0.80	3.07	3.65	3.91	3.4/A	
25+25+25+50	2.40	2.40	2.40	4.80	-	3.69	12.00	13.53	0.91	4.15	4.38	2.89	5.6/A	2.40	2.40	4.60	4.60	-	3.69	12.00	13.54	0.80	3.07	3.82	3.91	3.4/A	
25+25+25+70	2.19	2.19	2.19	5.84	-	3.69	12.40	13.53	0.91	4.29	4.38	2.89	5.6/A	2.17	2.17	2.17	5.79	-	3.69	12.30	13.54	0.80	3.15	3.82	3.91	3.4/A	
25+25+35+35	2.46	2.46	3.29	3.29	-	3.69	11.50	13.53	0.91	3.95	4.19	2.91	5.6/A	2.57	2.57	3.43	3.43	-	3.69	12.00	13.54	0.80	3.07	3.65	3.91	3.4/A	
25+25+35+50	2.25	2.25	3.00	4.50	-	3.69	12.00	13.53	0.91	4.15	4.38	2.89	5.6/A	2.25	2.25	3.00	4.50	-	3.69	12.00	13.54	0.80	3.07	3.82	3.91	3.4/A	
25+25+35+70	2.07	2.07	2.76	5.51	-	3.69	12.40	13.53	0.91	4.29	4.38	2.89	5.6/A	2.05	2.05	2.73	5.47	-	3.69	12.30	13.54	0.80	3.15	3.82	3.91	3.4/A	
25+25+50+50	2.07	2.07	4.13	4.13	-	3.69	12.40	13.53	0.91	4.29	4.38	2.89	5.6/A	2.00	2.00	4.00	4.00	-	3.69	12.00	13.54	0.80	3.07	3.82	3.91	3.4/A	
25+35+35+35	2.30	3.07	3.07	3.07	-	3.69	11.50	13.53	0.91	3.98	4.19	2.89	5.6/A	2.40	3.20	3.20	3.20	-	3.69	12.00	13.54	0.80	3.07	3.65	3.91	3.4/A	
25+35+35+50	2.19	2.92	2.92	4.38	-	3.69	12.40	13.53	0.91	4.29	4.38	2.89	5.6/A	2.12	2.82	2.82	4.24	-	3.69	12.00	13.54	0.80	3.07	3.82	3.91	3.4/A	
25+35+35+70	1.96	2.61	2.61	5.22	-	3.69	12.40	13.53	0.91	4.29	4.38	2.89	5.6/A	1.94	2.59	2.59	5.18	-	3.69	12.30	13.54	0.80	3.15	3.82	3.91	3.4/A	
25+35+50+50	1.96	2.61	3.92	3.92	-	3.69	12.40	13.53	0.91	4.29	4.38	2.89	5.6/A	1.89	2.53	3.79	3.79	-	3.69	12.00	13.54	0.80	3.07	3.82	3.91	3.4/A	
35+35+35+35	2.88	2.88	2.88	2.88	-	3.69	11.50	13.53	0.91	3.98	4.19	2.89	5.6/A	3.00	3.00	3.00	3.00	-	3.69	12.00	13.54	0.80	3.07	3.65	3.91	3.4/A	
35+35+35+50	2.76	2.76	2.76	4.13	-	3.69	12.40	13.53	0.91	4.29	4.38	2.89	5.6/A	2.67	2.67	2.67	4.00	-	3.69	12.00	13.54	0.80	3.07	3.82	3.91	3.4/A	
22+22+22+22+22	2.46	2.46	2.46	2.46	2.46	4.18	12.30	14.00	1.03	3.81	4.57	3.23	6.1/A++	2.46	2.46	2.46	2.46	2.46	4.19	12.30	14.96	0.90	3.32	4.15	3.71	3.8/A	
22+22+22+22+25	2.33	2.33	2.33	2.33	2.99	4.18	12.30	14.00	1.03	3.81	4.57	3.23	6.1/A++	2.33	2.33	2.33	2.99	4.19	12.30	14.96	0.90	3.32	4.15	3.71	3.8/A		
22+22+22+22+35	2.15	2.15	2.15	2.15	3.69	4.18	12.30	14.00	1.03	3.81	4.57	3.23	6.1/A++	2.15	2.15	2.15	3.69	4.19	12.30	14.96	0.90	3.32	4.15	3.71	3.8/A		
22+22+22+22+50	1.87	1.87	1.87	1.87	4.81	4.18	12.30	14.00	1.03	3.81	4.57	3.23	6.1/A++	1.87	1.87	1.87	4.81	4.19	12.30	14.96	0.90	3.32	4.15	3.71	3.8/A		
22+22+22+22+70	1.66	1.66	1.66	1.66	5.68	4.18	12.30	14.00	1.03	3.81	4.57	3.23	6.1/A++	1.66	1.66	1.66	5.68	4.19	12.30	14.96	0.90	3.32	4.15	3.71	3.8/A		
22+22+22+25+25	2.21	2.21	2.21	2.84	2.84	4.18	12.30	14.00	1.03	3.81	4.57	3.23	6.1/A++	2.21	2.21	2.21	2.84	2.84	4.19	12.30	14.96	0.90	3.32	4.15	3.71	3.8/A	
22+22+22+25+35	2.05	2.05	2.05	2.64	3.51	4.18	12.30	14.00	1.03	3.81	4.57	3.23	6.1/A++	2.05	2.05	2.05	2.64	3.51	4.19	12.30	14.96	0.90	3.32	4.15	3.71	3.8/A	
22+22+22+25+50	1.79	1.79	1.79	2.31	4.61	4.18	12.30	14.00	1.03	3.81	4.57	3.23	6.1/A++	1.79	1.79	1.79	2.31	4.61	4.19	12.30	14.96	0.90	3.32	4.15	3.71	3.8/A	
22+22+22+25+70	1.59	1.59	1.59	2.05	5.47	4.18	12.30	14.00	1.03	3.81	4.57	3.23	6.1/A++	1.59	1.59	1.59	2.05	5.47	4.19	12.30	14.96	0.90	3.32	4.15	3.71	3.8/A	
22+22+22+35+35	1.91	1.91	1.91	3.28	3.28	4.18	12.30	14.00	1.03	3.81	4.57	3.23	6.1/A++	1.91	1.91	3.28	3.28	4.19	12.30	14.96	0.90	3.32	4.15	3.71	3.8/A		
22+22+22+35+50	1.69	1.69	1.69	2.89	4.34	4.18	12.30	14.00	1.03	3.81	4.57	3.23	6.1/A++	1.69	1.69	1.69	2.89	4.34	4.19	12.30	14.96	0.90	3.32	4.15	3.71	3.8/A	
22+22+22+35+70	1.51	1.51	1.51	2.59	5.18	4.18	12.30	14.00	1.03	3.81	4.57	3.23	6.1/A++	1.51	1.51	2.59	5.18	4.19	12.30	14.96	0.90	3.32	4.15	3.71	3.8/A		
22+22+22+50+50	1.51	1.51	1.51	3.88	3.88	4.18	12.30	14.00	1.03	3.81	4.57	3.23	6.1/A++	1.51	1.51	3.88	3.88	4.19	12.30	14.96	0.90	3.32	4.15	3.71	3.8/A		
22+22+22+50+70	2.10	2.10	2.70	2.70	2.70	4.18	12.30	14.00	1.03	3.81	4.57	3.23	6.1/A++	2.10	2.10	2.70	2.70	2.70	4.19	12.30	14.96	0.90	3.32	4.15	3.71	3.8/A	
22+22+25+25+25	1.96	1.96	2.52	2.52	3.35	4.18	12.30	14.00	1.03	3.81	4.57	3.23	6.1/A++	1.96	1.96	2.52	2.52	3.35	4.19	12.30	14.96	0.90	3.32	4.15	3.71	3.8/A	
22+22+25+25+50	1.72	1.72	2.21	2.21	4.43	4.18	12.30	14.00	1.03	3.81	4.57	3.23	6.1/A++	1.72	1.72	2.21	2.21	4.43	4.19								



DC Inverter
Reversible



HYBRID
HOUSE by Airwell



ZDAE Multisplit



ZDAE Duo/Trio/Quattro/ Cinco

+ PRODUCT

- Flexy Match (high wall/console compatible)
- 6 models from 4 to 12 kW and up to 5 indoor units
- Electronic expansion valve

FEATURES

TECHNOLOGY



ELECTRONIC
EXPANSION VALVE

INSTALLER FUNCTIONS



AUTO-DIAGNOSTIC

CERTIFICATION

- AIRWELL participates in the ECP programme for AC1. Check ongoing validity of certificate:

www.eurovent-certification.com



Compatible
WITH:

> High wall HDLE Aura
22/25/35/50/70



> Console XDLF
25/35/50



+ “SUSTAINABLE DEVELOPMENT”

> High energy label A++ (cooling mode) / A+ (heating mode).

+ “USER”

> Small footprint with a single outdoor unit.

+ “INSTALLER”

> The best reliability on the market.

+ “TECHNOLOGY”

> Extended range: even more power combinations.

> High resistance to “aggressive” environments (corrosion, voltage, high temperatures).

See technical draws page 152

TECHNICAL DATA

ZDAE

Multisplit

OUTDOOR UNIT		ZDAE-2040-09M25	ZDAE-2050-09M25	ZDAE-3060-09M25	ZDAE-3070-09M25	ZDAE-4080-09M25	ZDAE-5130-09M25
Part number		7SP091200	7SP091201	7SP091202	7SP091203	7SP091204	7SP091205
Phase		Single-phase	Single-phase	Single-phase	Single-phase	Single-phase	Single-phase

COOLING

Rated power (min./max.)	kW	4.10 (2.05-5.00)	5.30 (2.14-5.80)	6.10 (2.20-8.30)	7.10 (2.30-9.20)	8.00 (2.30-11.00)	12.00 (2.60-13.00)
Pdesignc	kW	4.10	5.30	6.10	7.10	8.00	12.00
Rated power input	kW	1.10	1.48	1.48	1.88	2.12	3.45
SEER/Energy label		6.3/A++	6.3/A++	6.6/A++	6.8/A++	6.7/A++	6.1/A++
Operating limits	°C	-15°/50° Dry bulb					

HEATING

Rated power (min./max.)	kW	4.40 (2.49-5.40)	5.65 (2.58-6.50)	6.50 (3.60-8.50)	8.60 (3.65-9.20)	9.50 (3.65-10.25)	13.00 (2.60-14.50)
Pdesignh (average climate)	kW	3.60	4.10	6.10	6.10	7.20	11.80
Rated power input	kW	0.97	1.25	1.41	2.23	2.20	3.50
SCOP/Energy label (average climate)		4.0/A+	4.0/A+	4.0/A+	4.0/A+	4.0/A+	4.0/A+
Power at -7°C	kW	3.21	4.69	5.33	6.36	6.65	9.10
Power at -10°C	kW	2.99	4.35	5.14	6.19	6.27	8.58
Power at -15°C	kW	2.68	3.84	4.75	5.76	5.80	7.93
Operating limits	°C	-15°/24° Dry bulb					

OUTDOOR UNIT

Sound pressure level at 1 m	dB(A)	50	50	57	57	58	60
Sound level	dB(A)	62	64	68	68	68	70
Airflow	m ³ /h	2300	2300	3800	3800	3800	5200
Compressor type		Rotary	Rotary	Rotary	Rotary	Rotary	Rotary
Outline dimensions (WxHxD)	mm	745x550x300	745x550x300	889x654x340	889x654x340	889x654x340	1098x1106x440
Package dimensions (WxHxD)	mm	872x620x398	872x620x398	1032x737x456	1032x737x456	1032x737x456	1158x1235x493
Net weight/Gross weight	kg	30/33	32/35	48/52	48/52	51/56	90/98

POWER SUPPLY

Phase/Voltage/Frequency		1P/230V/50Hz	1P/230V/50Hz	1P/230V/50Hz	1P/230V/50Hz	1P/230V/50Hz	1P/230V/50Hz
Power supply side		Outdoor	Outdoor	Outdoor	Outdoor	Outdoor	Outdoor
Power cable section	mm ²	3G4	3G4	3G4	3G4	3G4	3G4
Fuse rating am	A	16	16	25	25	25	25
Electrical connections in/out	mm ²	2 x (4G1.5)	2 x (4G1.5)	3x (4G1.5)	3x (4G1.5)	4 x (4G1.5)	5 x (4G1.5)

PIPE LINE

Suction pipe diameter	inches	3/8"	3/8"	3/8"	3/8"	3/8"	3/8"
Liquid pipe diameter	inches	1/4"	1/4"	1/4"	1/4"	1/4"	1/4"
Max. length	m	40	40	60	60	70	75
Max. length per circuit	m	20	20	20	20	20	25
Max. height between indoor and outdoor unit	Outdoor unit higher than indoor unit	m	15	15	15	15	15
	Outdoor unit lower than indoor unit	m	15	15	15	15	15
Max. height between indoor units	m	15	15	15	15	15	8
Refrigerant/GWP		R32/675	R32/675	R32/675	R32/675	R32/675	R32/675
Charge	kg	0.75	0.90	1.60	1.70	1.80	2.75
Totale length charge	m	10	10	30	30	40	40
Additional charge	g/m	20	20	20	20	20	20



High wall HDLE Aura
22/25/35/50/70

INDOOR UNIT		HDLE-022N-09M25	HDLE-025N-09M25	HDLE-035N-09M25	HDLE-050N-09M25	HDLE-070N-09M25
Part number		7SP023270	7SP023271	7SP023272	7SP023273	7SP023274
Phase		Single-phase	Single-phase	Single-phase	Single-phase	Single-phase
Cooling rated power	kW	2.20	2.70	3.20	4.60	6.20
Heating rated power	kW	2.40	2.80	3.40	5.20	6.50
Sound pressure level at 1 m (VL/LS/MS/HS)	dB (A)	22/33/36/39	21/34/38/41	21/34/38/41	27/38/42/44	26/37/45/48
Sound level (VL/LS/MS/HS)	dB (A)	37/45/48/55	36/46/50/57	34/45/50/57	41/48/52/54	42/49/57/60
Airflow (VL/LS/MS/HS)	m ³ /h	290/420/470/500	280/400/520/550	280/410/480/590	550/700/800/850	400/600/800/900
Dehumidification	l/h	0.60	1.40	1.40	1.80	1.80
Outline dimensions (WxHxD)	mm	713x270x195	790x275x200	790x275x200	970x300x224	970x300x224
Package dimensions (WxHxD)	mm	776x362x268	866x367x271	866x367x271	1041x383x320	1041x383x320
Net weight/Gross weight	kg	8/9.5	9/11	9/11	13.5/16	13/15.5

PIPE LINE

Suction pipe diameter	inches	3/8"	3/8"	3/8"	3/8"	1/2"
Liquid pipe diameter	inches	1/4"	1/4"	1/4"	1/4"	1/4"



Console XDLE
25/35/50

INDOOR UNIT		XDLE-025N-09M25	XDLE-035N-09M25	XDLE-050N-09M25
Part number		7SP071440	7SP071441	7SP071442
Phase		Single-phase	Single-phase	Single-phase
Cooling rated power	kW	2.70	3.50	5.20
Heating rated power	kW	2.90	3.80	5.33
Sound pressure level at 1 m (VL/LS/MS/HS)	dB(A)	23/26/33/39	25/29/38/44	32/37/43/47
Sound level	dB(A)	34/38/45/50	35/39/48/54	42/47/53/57
Airflow (VL/LS/MS/HS)	m ³ /h	250/280/410/500	280/360/480/600	320/410/580/700
Dehumidification	l/h	0.80	1.20	1.80
Outline dimensions (WxHxD)	mm	700x600x215	700x600x215	700x600x215
Package dimensions (WxHxD)	mm	788x685x295	788x685x295	788x685x295
Net weight/Gross weight	kg	15.5/18.5	15.5/18.5	15.5/18.5

PIPE LINE

Suction pipe diameter	inches	3/8"	3/8"	1/2"
Liquid pipe diameter	inches	1/4"	1/4"	1/4"



Compatible
WITH:

> High wall HDLE Aura
22/25/35



> Console XDLF
25/35



ZDAE-2040 MULTISPLIT DUO

Indoor unit combination	COOLING										HEATING									
	Rated power (kW)		Total power (kW)			Total input power (kW)			EER	SEER/ Energy label	Rated power (kW)		Total power (kW)			Total input power (kW)			COP	SCOP/ Energy label
	Unit A	Unit B	Min.	Rated	Max.	Min.	Rated	Max.			Unit A	Unit B	Min.	Rated	Max.	Min.	Rated	Max.		
22+22	2.05	2.05	2.05	4.10	5.00	0.40	1.10	2.25	3.73	6.3/A++	2.20	2.20	2.50	4.40	5.40	0.60	0.97	2.25	4.54	4.0/A+
22+25	1.79	2.31	2.05	4.10	5.00	0.40	1.10	2.25	3.73	6.3/A++	1.93	2.48	2.50	4.40	5.40	0.60	0.96	2.25	4.60	4.0/A+
22+35	1.51	2.59	2.05	4.10	5.00	0.40	1.10	2.25	3.73	6.3/A++	1.62	2.78	2.50	4.40	5.40	0.60	0.96	2.25	4.60	4.0/A+
25+25	2.05	2.05	2.05	4.10	5.00	0.40	1.10	2.25	3.73	6.3/A++	2.20	2.20	2.50	4.40	5.40	0.60	0.96	2.25	4.60	4.0/A+
25+35	1.76	2.34	2.05	4.10	5.00	0.40	1.10	2.25	3.73	6.3/A++	1.89	2.51	2.50	4.40	5.40	0.60	0.96	2.25	4.60	4.0/A+

Based on wall mounted combination

ZDAE-2050 MULTISPLIT DUO

Indoor unit combination	COOLING										HEATING									
	Rated power (kW)		Total power (kW)			Total input power (kW)			EER	SEER/ Energy label	Rated power (kW)		Total power (kW)			Total input power (kW)			COP	SCOP/ Energy label
	Unit A	Unit B	Min.	Rated	Max.	Min.	Rated	Max.			Unit A	Unit B	Min.	Rated	Max.	Min.	Rated	Max.		
22+22	2.10	2.10	2.15	4.20	4.80	0.40	1.40	2.00	3.00	6.3/A++	2.60	2.60	2.05	5.20	5.62	0.50	1.00	2.20	5.20	4.0/A+
22+25	2.10	2.60	2.15	4.70	5.20	0.40	1.44	2.00	3.26	6.3/A++	2.60	2.80	2.05	5.40	5.83	0.60	1.10	2.20	4.91	4.0/A+
22+35	2.10	3.10	2.15	5.20	5.80	0.40	1.48	2.50	3.51	6.3/A++	1.99	3.41	2.50	5.40	5.90	0.70	1.25	2.50	4.32	4.0/A+
25+25	2.60	2.60	2.15	5.20	5.80	0.40	1.48	2.50	3.58	6.3/A++	2.70	2.70	2.50	5.40	5.90	0.70	1.25	2.50	4.32	4.0/A+
25+35	2.23	2.97	2.15	5.20	5.80	0.50	1.48	2.50	3.51	6.3/A++	2.31	3.09	2.50	5.40	5.90	0.70	1.25	2.50	4.32	4.0/A+
35+35	2.60	2.60	2.15	5.20	5.80	0.50	1.48	2.50	3.51	6.3/A++	2.70	2.70	2.50	5.40	5.90	0.70	1.25	2.50	4.32	4.0/A+

Based on wall mounted combination

Optimum combinations

ZDAE Combination capacities



Compatible
WITH:

> High wall HDLE Aura
22/25/35/50

> Console XDLF
25/35/50



ZDAE-3060 MULTISPLIT TRIO

Indoor unit combination	COOLING											HEATING										
	Rated power (kW)			Total power (kW)			Total input power (kW)			EER	SEER/ Energy label	Rated power (kW)			Total power (kW)			Total input power (kW)			COP	SCOP/ Energy label
	Unit A	Unit B	Unit C	Min.	Rated	Max.	Min.	Rated	Max.			Unit A	Unit B	Unit C	Min.	Rated	Max.	Min.	Rated	Max.		
22+22	2.10	2.10	-	2.20	4.20	5.60	0.40	0.90	2.00	4.67	6.1/A++	2.60	2.60	-	3.60	5.20	8.50	0.40	0.95	2.20	5.47	3.8/A
22+25	2.10	2.60	-	2.20	4.70	5.60	0.40	1.00	2.40	4.70	6.1/A++	2.60	2.80	-	3.60	5.40	8.50	0.40	1.09	2.20	4.95	3.8/A
22+35	2.10	3.50	-	2.20	5.60	7.33	0.40	1.20	2.60	4.67	6.1/A++	2.60	3.80	-	3.60	6.40	8.50	0.60	1.29	2.50	4.96	3.8/A
22+50	1.71	4.39	-	2.20	6.10	7.33	0.50	1.48	2.90	4.12	6.1/A++	1.82	4.68	-	3.60	6.50	8.50	0.80	1.41	2.90	4.60	3.8/A
25+25	2.55	2.55	-	2.20	5.10	5.60	0.40	1.20	2.60	4.25	6.1/A++	2.80	2.80	-	3.60	5.60	8.50	0.60	1.22	2.50	4.60	3.8/A
25+35	2.61	3.49	-	2.20	6.10	7.33	0.50	1.48	2.90	4.12	6.1/A++	2.70	3.80	-	3.60	6.50	8.50	0.80	1.41	2.90	4.60	3.8/A
25+50	2.03	4.07	-	2.20	6.10	7.33	0.60	1.48	2.90	4.12	6.1/A++	2.17	4.33	-	3.60	6.50	8.50	0.80	1.41	2.90	4.60	3.8/A
35+35	3.05	3.05	-	2.20	6.10	7.33	0.60	1.48	2.90	4.12	6.1/A++	3.25	3.25	-	3.60	6.50	8.50	0.80	1.41	2.90	4.60	3.8/A
35+50	2.44	3.66	-	2.20	6.10	7.33	0.60	1.48	2.90	4.12	6.1/A++	2.60	3.90	-	3.60	6.50	8.50	0.80	1.41	2.90	4.60	3.8/A
22+22+22	2.03	2.03	2.03	2.20	6.10	7.33	0.60	1.48	2.90	4.12	6.6/A++	2.17	2.17	2.17	3.60	6.50	8.50	0.80	1.41	2.90	4.60	3.8/A
22+22+25	1.86	1.86	2.39	2.20	6.10	7.33	0.60	1.48	2.90	4.12	6.6/A++	1.98	1.98	2.54	3.60	6.50	8.50	0.80	1.41	2.90	4.60	3.8/A
22+22+35	1.64	1.64	2.82	2.20	6.10	7.33	0.60	1.48	2.90	4.12	6.6/A++	1.75	1.75	3.00	3.60	6.50	8.50	0.80	1.41	2.90	4.60	3.8/A
22+25+25	1.71	2.20	2.20	2.20	6.10	7.33	0.60	1.48	2.90	4.12	6.6/A++	1.82	2.34	2.34	3.60	6.50	8.50	0.80	1.41	2.90	4.60	3.8/A
22+25+35	1.53	1.96	2.61	2.20	6.10	7.33	0.60	1.48	2.90	4.12	6.6/A++	1.63	2.09	2.79	3.60	6.50	8.50	0.80	1.41	2.90	4.60	3.8/A
22+35+35	1.38	2.36	2.36	2.20	6.10	7.33	0.60	1.48	2.90	4.12	6.6/A++	1.47	2.52	2.52	3.60	6.50	8.50	0.80	1.41	2.90	4.60	3.8/A
25+25+25	2.03	2.03	2.03	2.20	6.10	7.33	0.60	1.48	2.90	4.12	6.6/A++	2.17	2.17	2.17	3.60	6.50	8.50	0.80	1.41	2.90	4.60	3.8/A
25+25+35	1.83	1.83	2.44	2.20	6.10	7.33	0.60	1.48	2.90	4.12	6.6/A++	1.95	1.95	2.60	3.60	6.50	8.50	0.80	1.41	2.90	4.60	3.8/A

Based on wall mounted combination

ZDAE-3070 MULTISPLIT TRIO

Indoor unit combination	COOLING											HEATING										
	Rated power (kW)			Total power (kW)			Total input power (kW)			EER	SEER/ Energy label	Rated power (kW)			Total power (kW)			Total input power (kW)			COP	SCOP/ Energy label
	Unit A	Unit B	Unit C	Min.	Rated	Max.	Min.	Rated	Max.			Unit A	Unit B	Unit C	Min.	Rated	Max.	Min.	Rated	Max.		
22+22	2.10	2.10	-	2.40	4.20	4.90	0.60	1.10	2.60	3.82	6.1/A++	2.60	2.60	-	3.60	5.20	8.80	0.60	1.30	2.00	4.00	3.8/A
22+25	2.10	2.60	-	2.40	4.70	5.20	0.60	1.25	2.80	3.76	6.1/A++	2.60	2.80	-	3.60	5.40	8.80	0.60	1.49	2.00	3.62	3.8/A
22+35	2.10	3.50	-	2.40	5.60	6.30	0.80	1.50	3.00	3.73	6.1/A++	2.60	3.80	-	3.60	6.40	8.80	0.60	1.77	2.40	3.62	3.8/A
22+50	1.99	5.11	-	2.40	7.10	8.50	1.00	1.88	3.40	3.78	6.1/A++	2.60	5.60	-	3.60	8.20	8.80	0.80	2.23	3.00	3.68	3.8/A
25+25	2.60	2.60	-	2.40	5.20	6.30	0.80	1.40	3.00	3.71	6.1/A++	2.60	2.60	-	3.60	5.20	8.80	0.60	1.67	2.40	3.11	3.8/A
25+35	2.60	3.50	-	2.40	6.10	7.30	1.00	1.65	3.20	3.70	6.1/A++	2.60	3.80	-	3.60	6.40	8.80	0.60	1.95	2.60	3.28	3.8/A
25+50	2.37	4.73	-	2.40	7.10	8.50	1.10	1.88	3.40	3.78	6.1/A++	2.80	5.60	-	3.60	8.40	8.80	0.80	2.23	3.00	3.77	3.8/A
35+35	3.55	3.55	-	2.40	7.10	8.50	1.10	1.88	3.40	3.78	6.1/A++	4.25	4.25	-	3.60	8.50	8.80	0.80	2.23	3.00	3.81	3.8/A
35+50	2.84	4.26	-	2.40	7.10	8.50	1.10	1.88	3.40	3.78	6.1/A++	3.40	5.10	-	3.60	8.50	8.80	0.80	2.23	3.00	3.81	3.8/A
50+50	3.55	3.55	-	2.40	7.10	8.50	1.10	1.88	3.40	3.78	6.1/A++	4.25	4.25	-	3.60	8.50	8.80	0.80	2.23	3.00	3.81	3.8/A
22+22+22	2.10	2.10	2.10	2.40	6.30	7.30	1.10	1.65	3.20	3.82	6.8/A++	2.60	2.60	2.60	3.60	7.80	8.80	0.80	1.95	2.60	4.00	3.8/A
22+22+25	2.10	2.10	2.60	2.40	6.80	8.50	1.10	1.80	3.40	3.78	6.8/A++	2.60	2.60	2.80	3.60	8.00	8.80	0.80	2.14	2.80	3.74	3.8/A
22+22+35	1.91	1.91	3.28	2.40	7.10	8.50	1.10	1.88	3.40	3.78	6.8/A++	2.29	2.29	3.92	3.60	8.50	8.80	0.80	2.23	3.00	3.81	3.8/A
22+22+50	1.55	1.55	3.99	2.40	7.10	8.50	1.10	1.88	3.40	3.78	6.8/A++	1.86	1.86	4.78	3.60	8.50	8.80	0.80	2.23	3.00	3.81	3.8/A
22+25+25	1.99	2.56	2.56	2.40	7.10	8.50	1.10	1.88	3.40	3.78	6.8/A++	2.38	3.06	3.06	3.60	8.50	8.80	0.80	2.23	3.00	3.81	3.8/A
22+25+35	1.78	2.28	3.04	2.40	7.10	8.50	1.10	1.88	3.40	3.78	6.8/A++	2.13	2.73	3.64	3.60	8.50	8.80	0.80	2.23	3.00	3.81	3.8/A
22+25+50	1.46	1.88	3.76	2.40	7.10	8.50	1.10	1.88	3.40	3.78	6.8/A++	1.75	2.25	4.50	3.60	8.50	8.80	0.80	2.23	3.00	3.81	3.8/A
22+35+35	1.60	2.75	2.75	2.40	7.10	8.50	1.10	1.88	3.40	3.78	6.8/A++	1.92	3.29	3.29	3.60	8.50	8.80	0.80	2.23	3.00	3.81	3.8/A
25+25+25	2.37	2.37	2.37	2.40	7.10	8.50	1.10	1.88	3.40	3.78	6.8/A++	2.83	2.83	2.83	3.60	8.50	8.80	0.80	2.23	3.00	3.81	3.8/A
25+25+35	2.13	2.13	2.84	2.40	7.10	8.50	1.10	1.88	3.40	3.78	6.8/A++	2.55	2.55	3.40	3.60	8.50	8.80	0.80	2.23	3.00	3.81	3.8/A
25+25+50	1.78	1.78	3.55	2.40	7.10	8.50	1.10	1.88	3.40	3.78	6.8/A++	2.13	2.13	4.25	3.60	8.50	8.80	0.80	2.23	3.00	3.81	3.8/A
25+35+35	1.94	2.58	2.58	2.40	7.10	8.50	1.10	1.88	3.40	3.78	6.8/A++	2.32	3.09	3.09	3.60	8.50	8.80	0.80	2.23	3.00	3.81	3.8/A
35+35+35	2.37	2.37	2.37	2.40	7.10	8.50	1.10	1.88	3.40	3.78	6.8/A++	2.83	2.83	2.83	3.60	8.50	8.80	0.80	2.23	3.00	3.81	3.8/A

Based on wall mounted combination

Optimum combinations



Compatible
WITH:

> High wall HDLE Aura
22/25/35/50



> Console XDLF
25/35/50



ZDAE-4080 MULTISPLIT QUATTRO

Indoor unit combination	COOLING											HEATING														
	Rated power (kW)				Total power (kW)			Total input power (kW)				EER	SEER/ Energy label	Rated power (kW)				Total power (kW)			Total input power (kW)				COP	SCOP/ Energy label
	Unit A	Unit B	Unit C	Unit D	Min.	Rated	Max.	Min.	Rated	Max.	Unit A			Unit B	Unit C	Unit D	Min.	Rated	Max.	Min.	Rated	Max.				
22+22	2.10	2.10	-	-	2.50	4.20	4.54	0.80	1.10	2.40	3.82	6.1/A++	2.60	2.60	-	-	3.60	5.20	10.00	0.70	1.10	2.50	4.73	3.8/A		
22+25	2.10	2.60	-	-	2.50	4.70	5.08	0.80	1.20	2.60	3.92	6.1/A++	2.60	2.80	-	-	3.60	5.40	10.00	0.70	1.26	2.50	4.29	3.8/A		
22+35	2.10	3.50	-	-	2.50	5.60	6.05	0.80	1.44	2.60	3.89	6.1/A++	2.60	3.80	-	-	3.60	6.40	10.00	0.70	1.49	2.50	4.30	3.8/A		
22+50	2.10	5.00	-	-	2.50	7.10	7.67	1.00	1.90	3.00	3.74	6.1/A++	2.60	5.60	-	-	3.60	8.20	10.00	0.90	1.96	3.00	4.18	3.8/A		
25+25	2.60	2.60	-	-	2.50	5.20	5.62	0.80	1.40	2.60	3.71	6.1/A++	2.80	2.80	-	-	3.60	5.60	10.00	0.70	1.41	2.50	3.97	3.8/A		
25+35	2.60	3.50	-	-	2.50	6.10	6.59	0.80	1.60	2.80	3.81	6.1/A++	2.80	5.43	-	-	3.60	8.23	10.00	0.70	1.65	2.60	4.99	3.8/A		
25+50	2.60	5.00	-	-	2.50	7.60	8.21	1.20	2.00	2.80	3.80	6.1/A++	2.80	3.80	-	-	3.60	6.60	10.00	1.00	2.12	3.40	3.11	3.8/A		
35+35	3.50	3.50	-	-	2.50	7.00	7.56	1.20	1.80	2.80	3.89	6.1/A++	3.80	3.80	-	-	3.60	7.60	10.00	0.90	1.89	2.80	4.02	3.8/A		
35+50	3.20	4.80	-	-	2.50	8.00	10.00	1.20	2.12	3.40	3.77	6.1/A++	3.80	5.60	-	-	3.60	9.40	10.00	1.00	2.20	3.60	4.27	3.8/A		
50+50	4.00	4.00	-	-	2.50	8.00	10.00	1.20	2.12	3.60	3.77	6.1/A++	4.75	4.75	-	-	3.60	9.50	10.00	1.00	2.20	3.60	4.32	3.8/A		
22+22+22	2.10	2.10	2.10	-	2.50	6.30	6.80	1.20	1.60	2.80	3.94	6.1/A++	2.60	2.60	2.60	-	3.60	7.80	10.00	0.70	1.65	2.60	4.73	3.8/A		
22+22+25	2.10	2.10	2.60	-	2.50	6.80	7.34	1.20	1.75	2.80	3.89	6.1/A++	2.60	2.60	2.80	-	3.60	8.00	10.00	0.90	1.81	2.80	4.42	3.8/A		
22+22+35	2.10	2.10	3.50	-	2.50	7.70	8.32	1.20	2.00	3.00	3.85	6.1/A++	2.60	2.60	3.80	-	3.60	9.00	10.00	0.90	2.04	3.00	4.41	3.8/A		
22+22+50	1.75	1.75	4.50	-	2.50	8.00	10.00	1.30	2.12	3.60	3.77	6.1/A++	2.08	2.08	5.34	-	3.60	9.50	10.00	1.00	2.20	3.60	4.32	3.8/A		
22+25+25	2.10	2.88	2.88	-	2.50	7.86	8.49	1.30	1.90	3.00	4.14	6.1/A++	2.60	2.80	2.80	-	3.60	8.20	10.00	0.90	1.96	3.00	4.18	3.8/A		
22+25+35	2.00	2.57	3.43	-	2.50	8.00	10.00	1.30	2.12	3.60	3.77	6.1/A++	2.60	2.80	4.00	-	3.60	9.40	10.00	1.00	2.20	3.60	4.27	3.8/A		
22+25+50	1.65	2.12	4.24	-	2.50	8.00	10.00	1.30	2.12	3.60	3.77	6.1/A++	1.96	2.51	5.03	-	3.60	9.50	10.00	1.00	2.20	3.60	4.32	3.8/A		
22+35+35	1.81	3.10	3.10	-	2.50	8.00	10.00	1.30	2.12	3.60	3.77	6.1/A++	2.50	3.50	3.50	-	3.60	9.50	10.00	1.00	2.20	3.60	4.32	3.8/A		
22+35+50	1.51	2.59	3.89	-	2.50	8.00	10.00	1.30	2.12	3.60	3.77	6.1/A++	1.80	3.08	4.62	-	3.60	9.50	10.00	1.00	2.20	3.60	4.32	3.8/A		
25+25+25	2.67	2.67	2.67	-	2.50	8.00	8.64	1.30	2.00	3.40	4.00	6.1/A++	3.17	3.17	3.17	-	3.60	9.50	10.00	1.00	2.12	3.40	4.48	3.8/A		
25+25+35	2.40	2.40	3.20	-	2.50	8.00	10.00	1.30	2.12	3.60	3.77	6.1/A++	2.85	2.85	3.80	-	3.60	9.50	10.00	1.00	2.20	3.60	4.32	3.8/A		
25+25+50	2.00	2.00	4.00	-	2.50	8.00	10.00	1.30	2.12	3.60	3.77	6.1/A++	2.38	2.38	4.75	-	3.60	9.50	10.00	1.00	2.20	3.60	4.32	3.8/A		
25+35+35	2.18	2.91	2.91	-	2.50	8.00	10.00	1.30	2.12	3.60	3.77	6.1/A++	2.59	3.45	3.45	-	3.60	9.50	10.00	1.00	2.20	3.60	4.32	3.8/A		
25+35+50	1.85	2.46	3.69	-	2.50	8.00	10.00	1.30	2.12	3.60	3.77	6.1/A++	2.19	2.92	4.38	-	3.60	9.50	10.00	1.00	2.20	3.60	4.32	3.8/A		
35+35+35	2.67	2.67	2.67	-	2.50	8.00	10.00	1.30	2.12	3.60	3.77	6.1/A++	3.17	3.17	3.17	-	3.60	9.50	10.00	1.00	2.20	3.60	4.32	3.8/A		
35+35+50	2.29	2.29	3.43	-	2.50	8.00	10.00	1.30	2.12	3.60	3.77	6.1/A++	2.71	2.71	4.07	-	3.60	9.50	10.00	1.00	2.20	3.60	4.32	3.8/A		
22+22+22+22	2.00	2.00	2.00	2.00	2.50	8.00	10.00	1.30	2.12	3.60	3.77	6.7/A++	2.38	2.38	2.38	2.38	3.60	9.50	10.00	1.00	2.20	3.60	4.32	3.8/A		
22+22+22+25	1.87	1.87	1.87	2.40	2.50	8.00	10.00	1.30	2.12	3.60	3.77	6.7/A++	2.22	2.22	2.22	2.85	3.60	9.50	10.00	1.00	2.20	3.60	4.32	3.8/A		
22+22+22+35	1.70	1.70	1.70	2.91	2.50	8.00	10.00	1.30	2.12	3.60	3.77	6.7/A++	2.02	2.02	2.02	3.45	3.60	9.50	10.00	1.00	2.20	3.60	4.32	3.8/A		
22+22+22+50	1.44	1.44	1.44	3.69	2.50	8.00	10.00	1.30	2.12	3.60	3.77	6.7/A++	1.71	1.71	1.71	4.38	3.60	9.50	10.00	1.00	2.20	3.60	4.32	3.8/A		
22+22+25+25	1.75	1.75	2.25	2.25	2.50	8.00	10.00	1.30	2.12	3.60	3.77	6.7/A++	2.08	2.08	2.67	2.67	3.60	9.50	10.00	1.00	2.20	3.60	4.32	3.8/A		
22+22+25+35	1.60	1.60	2.06	2.74	2.50	8.00	10.00	1.30	2.12	3.60	3.77	6.7/A++	1.90	1.90	2.44	3.26	3.60	9.50	10.00	1.00	2.20	3.60	4.32	3.8/A		
22+22+25+50	1.37	1.37	1.76	3.51	2.50	8.00	10.00	1.30	2.12	3.60	3.77	6.7/A++	1.62	1.62	2.09	4.17	3.60	9.50	10.00	1.00	2.20	3.60	4.32	3.8/A		
22+22+35+35	1.47	1.47	2.53	2.53	2.50	8.00	10.00	1.30	2.12	3.60	3.77	6.7/A++	1.75	1.75	3.00	3.00	3.60	9.50	10.00	1.00	2.20	3.60	4.32	3.8/A		
22+25+25+25	1.65	2.12	2.12	2.12	2.50	8.00	10.00	1.30	2.12	3.60	3.77	6.7/A++	1.96	2.51	2.51	2.51	3.60	9.50	10.00	1.00	2.20	3.60	4.32	3.8/A		
22+25+25+35	1.51	1.95	1.95	2.59	2.50	8.00	10.00	1.30	2.12	3.60	3.77	6.7/A++	1.80	2.31	2.31	3.08	3.60	9.50	10.00	1.00	2.20	3.60	4.32	3.8/A		
22+25+35+35	1.40	1.80	2.40	2.40	2.50	8.00	10.00	1.30	2.12	3.60	3.77	6.7/A++	1.66	2.14	2.85	2.85	3.60	9.50	10.00	1.00	2.20	3.60	4.32	3.8/A		
25+25+25+25	2.00	2.00	2.00	2.00	2.50	8.00	10.00	1.30	2.12	3.60	3.77	6.7/A++	2.38	2.38	2.38	2.38	3.60	9.50	10.00	1.00	2.20	3.60	4.32	3.8/A		
25+25+25+35	1.85	1.85	1.85	2.46	2.50	8.00	10.00	1.30	2.12	3.60	3.77	6.7/A++	2.19	2.19	2.19	2.92	3.60	9.50	10.00	1.00	2.20	3.60	4.32	3.8/A		
25+25+35+35	1.71	1.71	2.29	2.29	2.50	8.00	10.00	1.30	2.12	3.60	3.77	6.7/A++	2.04	2.04	2.71	2.71	3.60	9.50	10.00	1.00	2.20	3.60	4.32	3.8/A		

Based on wall mounted combination

Optimum combinations

DC Inverter
Reversible

ZDAE

Combination capacities



Compatible
WITH:

> High wall HDLE Aura
22/25/35/50/70

> Console XDLF
25/35/50



ZDAE-5130 MULTISPLIT CINCO

Indoor unit combination	COOLING											HEATING														
	Rated power (kW)				Total power (kW)			Total input power (kW)			EER	SEER/ Energy label	Rated power (kW)				Total power (kW)			Total input power (kW)		COP	SCOP/ Energy label			
	Unit A	Unit B	Unit C	Unit E	Unit D	Min.	Rated	Max.	Min.	Rated			Max.	Unit A	Unit B	Unit C	Unit D	Unit E	Min.	Rated	Max.			Min.	Rated	Max.
22+50	2.10	5.00	-	-	-	2.40	7.10	7.67	2.60	3.45	4.00	2.06	6.1/A++	2.60	5.60	-	-	-	2.60	8.20	13.00	1.61	3.20	4.00	2.56	4.0/A+
22+70	2.10	7.20	-	-	-	2.40	9.30	10.04	2.60	3.45	4.00	2.70	6.1/A++	2.60	8.50	-	-	-	2.60	11.10	13.00	1.61	3.20	4.00	3.47	4.0/A+
25+35	2.60	3.50	-	-	-	2.40	6.10	6.59	2.60	3.45	4.00	1.77	6.1/A++	2.80	3.80	-	-	-	2.60	6.60	13.00	1.61	3.20	4.00	2.06	4.0/A+
25+50	2.60	5.00	-	-	-	2.40	7.60	8.21	2.60	3.45	4.00	2.20	6.1/A++	2.80	5.60	-	-	-	2.60	8.40	13.00	1.61	3.20	4.00	2.63	4.0/A+
25+70	2.60	7.20	-	-	-	2.40	9.80	10.58	2.60	3.45	4.00	2.84	6.1/A++	2.80	8.50	-	-	-	2.60	11.30	13.00	1.61	3.20	4.00	3.53	4.0/A+
35+35	3.50	3.50	-	-	-	2.40	7.00	7.56	2.60	3.45	4.00	2.03	6.1/A++	3.80	3.80	-	-	-	2.60	7.60	13.00	1.61	3.20	4.00	2.38	4.0/A+
35+50	3.50	5.00	-	-	-	2.40	8.50	9.18	2.60	3.45	4.00	2.46	6.1/A++	3.80	5.60	-	-	-	2.60	9.40	13.00	1.61	3.20	4.00	2.94	4.0/A+
35+70	3.50	7.20	-	-	-	2.40	10.70	11.56	2.60	3.45	4.00	3.10	6.1/A++	3.80	8.50	-	-	-	2.60	12.30	13.00	1.61	3.20	4.00	3.84	4.0/A+
50+50	5.00	5.00	-	-	-	2.40	10.00	10.80	2.60	3.45	4.00	2.90	6.1/A++	5.60	5.60	-	-	-	2.60	11.20	13.00	1.61	3.20	4.00	3.50	4.0/A+
50+70	5.14	6.86	-	-	-	2.40	12.00	13.60	2.60	3.45	4.00	3.48	6.1/A++	5.57	7.43	-	-	-	2.60	13.00	13.00	1.61	3.20	4.00	4.06	4.0/A+
70+70	6.00	6.00	-	-	-	2.40	12.00	13.60	2.60	3.45	4.00	3.48	6.1/A++	6.50	6.50	-	-	-	2.60	13.00	13.00	1.61	3.20	4.00	4.06	4.0/A+
22+22+22	2.10	2.10	2.10	-	-	2.40	6.30	6.80	2.60	3.45	4.00	1.83	6.1/A++	2.60	2.60	2.60	-	-	2.60	7.80	13.00	1.61	3.20	4.00	2.44	4.0/A+
22+22+25	2.10	2.10	2.60	-	-	2.40	6.80	7.34	2.60	3.45	4.00	1.97	6.1/A++	2.60	2.60	2.80	-	-	2.60	8.00	13.00	1.61	3.20	4.00	2.50	4.0/A+
22+22+35	2.10	2.10	3.50	-	-	2.40	7.70	8.32	2.60	3.45	4.00	2.23	6.1/A++	2.60	2.60	3.80	-	-	2.60	9.00	13.00	1.61	3.20	4.00	2.81	4.0/A+
22+22+50	2.10	2.10	5.00	-	-	2.40	9.20	9.94	2.60	3.45	4.00	2.67	6.1/A++	2.60	2.60	5.60	-	-	2.60	10.80	13.00	1.61	3.20	4.00	3.38	4.0/A+
22+22+70	2.10	2.10	7.20	-	-	2.40	11.40	12.31	2.60	3.45	4.00	3.30	6.1/A++	2.60	2.60	7.80	-	-	2.60	13.00	13.00	1.61	3.20	4.00	4.06	4.0/A+
22+25+25	2.10	2.60	2.60	-	-	2.40	7.30	7.88	2.60	3.45	4.00	2.12	6.1/A++	2.60	2.80	2.80	-	-	2.60	8.20	13.00	1.61	3.20	4.00	2.56	4.0/A+
22+25+35	2.10	2.60	3.50	-	-	2.40	8.20	8.86	2.60	3.45	4.00	2.38	6.1/A++	2.60	2.80	3.80	-	-	2.60	9.20	13.00	1.61	3.20	4.00	2.88	4.0/A+
22+25+50	2.10	2.60	5.00	-	-	2.40	9.70	10.48	2.60	3.45	4.00	2.81	6.1/A++	2.60	2.80	5.60	-	-	2.60	11.00	13.00	1.61	3.20	4.00	3.44	4.0/A+
22+25+70	2.10	2.60	7.20	-	-	2.40	11.90	12.85	2.60	3.45	4.00	3.45	6.1/A++	2.60	2.80	7.60	-	-	2.60	13.00	13.00	1.61	3.20	4.00	4.06	4.0/A+
22+35+35	2.10	3.50	3.50	-	-	2.40	9.10	9.83	2.60	3.45	4.00	2.64	6.1/A++	2.60	3.80	3.80	-	-	2.60	10.20	13.00	1.61	3.20	4.00	3.19	4.0/A+
22+35+50	2.10	3.50	5.00	-	-	2.40	10.60	11.45	2.60	3.45	4.00	3.07	6.1/A++	2.60	3.80	5.60	-	-	2.60	12.00	13.00	1.61	3.20	4.00	3.75	4.0/A+
22+35+70	1.95	3.50	7.20	-	-	2.40	12.00	13.60	2.60	3.45	4.00	3.48	6.1/A++	2.12	3.63	7.26	-	-	2.60	13.00	13.00	1.61	3.20	4.00	4.06	4.0/A+
22+50+50	1.95	5.00	5.00	-	-	2.40	12.00	13.60	2.60	3.45	4.00	3.48	6.1/A++	2.12	5.44	5.44	-	-	2.60	13.00	13.00	1.61	3.20	4.00	4.06	4.0/A+
22+50+70	1.71	4.41	5.88	-	-	2.40	12.00	13.60	2.60	3.45	4.00	3.48	6.1/A++	1.86	4.78	6.37	-	-	2.60	13.00	13.00	1.61	3.20	4.00	4.06	4.0/A+
22+70+70	1.53	5.24	5.24	-	-	2.40	12.00	13.60	2.60	3.45	4.00	3.48	6.1/A++	1.65	5.67	5.67	-	-	2.60	13.00	13.00	1.61	3.20	4.00	4.06	4.0/A+
25+25+25	2.60	2.60	2.60	-	-	2.40	7.80	8.42	2.60	3.45	4.00	2.26	6.1/A++	2.80	2.80	2.80	-	-	2.60	8.40	13.00	1.61	3.20	4.00	2.63	4.0/A+
25+25+35	2.60	2.60	3.50	-	-	2.40	8.70	9.40	2.60	3.45	4.00	2.52	6.1/A++	2.80	2.80	3.80	-	-	2.60	9.40	13.00	1.61	3.20	4.00	2.94	4.0/A+
25+25+50	2.60	2.60	5.00	-	-	2.40	10.20	11.02	2.60	3.45	4.00	2.96	6.1/A++	2.80	2.80	5.60	-	-	2.60	11.20	13.00	1.61	3.20	4.00	3.50	4.0/A+
25+25+70	2.57	2.57	6.86	-	-	2.40	12.00	13.60	2.60	3.45	4.00	3.48	6.1/A++	2.79	2.79	7.43	-	-	2.60	13.00	13.00	1.61	3.20	4.00	4.06	4.0/A+
25+35+35	2.60	3.50	3.50	-	-	2.40	9.60	10.37	2.60	3.45	4.00	2.78	6.1/A++	2.80	3.80	3.80	-	-	2.60	10.40	13.00	1.61	3.20	4.00	3.25	4.0/A+
25+35+50	2.60	3.50	5.00	-	-	2.40	11.10	11.99	2.60	3.45	4.00	3.22	6.1/A++	2.80	3.80	5.60	-	-	2.60	12.20	13.00	1.61	3.20	4.00	3.81	4.0/A+
25+35+70	2.40	3.20	6.40	-	-	2.40	12.00	13.60	2.60	3.45	4.00	3.48	6.1/A++	2.60	3.47	6.93	-	-	2.60	13.00	13.00	1.61	3.20	4.00	4.06	4.0/A+
25+50+50	2.40	4.80	4.80	-	-	2.40	12.00	13.60	2.60	3.45	4.00	3.48	6.1/A++	2.60	5.20	5.20	-	-	2.60	13.00	13.00	1.61	3.20	4.00	4.06	4.0/A+
25+50+70	2.12	4.24	5.65	-	-	2.40	12.00	13.60	2.60	3.45	4.00	3.48	6.1/A++	2.29	4.59	6.12	-	-	2.60	13.00	13.00	1.61	3.20	4.00	4.06	4.0/A+
25+70+70	1.89	5.05	5.05	-	-	2.40	12.00	13.60	2.60	3.45	4.00	3.48	6.1/A++	2.05	5.47	5.47	-	-	2.60	13.00	13.00	1.61	3.20	4.00	4.06	4.0/A+
35+35+35	3.50	3.50	3.50	-	-	2.40	10.50	11.34	2.60	3.45	4.00	3.04	6.1/A++	4.33	4.33	4.33	-	-	2.60	13.00	13.00	1.61	3.20	4.00	4.06	4.0/A+
35+35+50	3.43	3.43	5.14	-	-	2.40	12.00	13.60	2.60	3.45	4.00	3.48	6.1/A++	3.71	3.71	5.57	-	-	2.60	13.00	13.00	1.61	3.20	4.00	4.06	4.0/A+
35+35+70	3.00	3.00	6.00	-	-	2.40	12.00	13.60	2.60	3.45	4.00	3.48	6.1/A++	3.25	3.25	6.50	-	-	2.60	13.00	13.00	1.61	3.20	4.00	4.06	4.0/A+
35+50+50	3.00	4.50	4.50	-	-	2.40	12.00	13.60	2.60	3.45	4.00	3.48	6.1/A++	3.25	4.88	4.88	-	-	2.60	13.00	13.00	1.61	3.20	4.00	4.06	4.0/A+
35+50+70	2.67	4.00	5.33	-	-	2.40	12.00	13.60	2.60	3.45	4.00	3.48	6.1/A++	2.89	4.33	5.78	-	-	2.60	13.00	13.00	1.61	3.20	4.00	4.06	4.0/A+
35+70+70	2.40	4.80	4.80	-	-	2.40	12.00	13.60	2.60	3.45	4.00	3.48	6.1/A++	2.60	5.20	5.20	-	-	2.60	13.00	13.00	1.61	3.20	4.00	4.06	4.0/A+
50+50+50	4.00	4.00	4.00	-	-	2.40	12.00	13.60	2.60	3.45	4.00	3.48	6.1/A++	4.33	4.33	4.33	-	-	2.60	13.00	13.00	1.61	3.20	4.00	4.06	4.0/A+
50+50+70	3.60	3.60	4.80	-	-	2.40	12.00	13.60	2.60	3.45	4.00	3.48	6.1/A++	3.90	3.90	5.20	-	-	2.60	13.00	13.00	1.61	3.20	4.00	4.06	4.0/A+
22+22+22+22	2.10	2.10	2.10	2.10	-	2.40	8.40	9.07	2.60	3.45	4.00	2.43	6.1/A++	2.60	2.60	2.60	2.60	-	2.60	13.00	13.00	1.61	3.20	4.00	4.06	4.0/A+
22+22+22+25	2.10	2.10	2.10	2.60	-	2.40	8.90	9.61	2.60	3.45	4.00	2.58	6.1/A++	2.60	2.60	2.60	2.80	-	2.60	13.00	13.00	1.61	3.20	4.00	4.06	4.0/A+
22+22+22+35	2.10	2.10	2.10	3.50	-	2.40	9.80	10.58	2.60	3.45	4.00	2.84	6.1/A++	2.60	2.60	2.60	3.80	-	2.60	13.00	13.00	1.61	3.20	4.00	4.06	4.0/A+
22+22+22+50	2.10	2.10	2.10	5.00	-	2.40	11.30	12.20	2.60	3.45	4.00	3.28	6.1/A++	2.60	2.60	2.60	5.60	-	2.60	13.00	13.00	1.61	3.20	4.00	4.06	4.0/A+
22+22+22+70	1.87	1.87	1.87	6.40	-	2.40	12.00	13.60	2.60																	

Indoor unit combination	COOLING												HEATING														
	Rated power (kW)					Total input power (kW)					EER	SEER/ Energy label	Rated power (kW)					Total input power (kW)					COP	SCOP/ Energy label			
	Unit A	Unit B	Unit C	Unit E	Unit D	Min.	Rated	Max.	Min.	Rated			Max.	Unit A	Unit B	Unit C	Unit D	Unit E	Min.	Rated	Max.	Min.			Rated	Max.	
22+25+50+70	1.45	1.86	3.72	4.97	-	2.40	12.00	13.60	2.60	3.45	4.00	3.48	6.1/A++	1.57	2.02	4.03	5.38	-	2.60	13.00	13.00	1.61	3.20	4.00	4.06	4.0/A+	
22+35+35+35	1.95	3.35	3.35	3.35	-	2.40	12.00	13.60	2.60	3.45	4.00	3.48	6.1/A++	2.12	3.63	3.63	3.63	-	2.60	13.00	13.00	1.61	3.20	4.00	4.06	4.0/A+	
22+35+35+50	1.71	2.94	2.94	4.41	-	2.40	12.00	13.60	2.60	3.45	4.00	3.48	6.1/A++	1.86	3.18	3.18	4.78	-	2.60	13.00	13.00	1.61	3.20	4.00	4.06	4.0/A+	
22+35+35+70	1.53	2.62	2.62	5.24	-	2.40	12.00	13.60	2.60	3.45	4.00	3.48	6.1/A++	1.65	2.84	2.84	5.67	-	2.60	13.00	13.00	1.61	3.20	4.00	4.06	4.0/A+	
22+35+50+50	1.53	2.62	3.93	3.93	-	2.40	12.00	13.60	2.60	3.45	4.00	3.48	6.1/A++	1.65	2.84	4.25	4.25	-	2.60	13.00	13.00	1.61	3.20	4.00	4.06	4.0/A+	
22+35+50+70	1.38	2.36	3.54	4.72	-	2.40	12.00	13.60	2.60	3.45	4.00	3.48	6.1/A++	1.49	2.56	3.84	5.11	-	2.60	13.00	13.00	1.61	3.20	4.00	4.06	4.0/A+	
22+50+50+50	1.38	3.54	3.54	3.54	-	2.40	12.00	13.60	2.60	3.45	4.00	3.48	6.1/A++	1.49	3.84	3.84	3.84	-	2.60	13.00	13.00	1.61	3.20	4.00	4.06	4.0/A+	
25+25+25+25	2.60	2.60	2.60	2.60	-	2.40	10.40	11.23	2.60	3.45	4.00	3.01	6.1/A++	3.25	3.25	3.25	3.25	-	2.60	13.00	13.00	1.61	3.20	4.00	4.06	4.0/A+	
25+25+25+35	2.60	2.60	2.60	3.50	-	2.40	11.30	12.20	2.60	3.45	4.00	3.28	6.1/A++	3.00	3.00	3.00	4.00	-	2.60	13.00	13.00	1.61	3.20	4.00	4.06	4.0/A+	
25+25+25+50	2.40	2.40	2.40	4.80	-	2.40	12.00	13.60	2.60	3.45	4.00	3.48	6.1/A++	2.60	2.60	2.60	5.00	-	2.60	13.00	13.00	1.61	3.20	4.00	4.06	4.0/A+	
25+25+25+70	2.12	2.12	2.12	5.65	-	2.40	12.00	13.60	2.60	3.45	4.00	3.48	6.1/A++	2.29	2.29	2.29	6.12	-	2.60	13.00	13.00	1.61	3.20	4.00	4.06	4.0/A+	
25+25+35+35	2.57	2.57	3.43	3.43	-	2.40	12.00	13.60	2.60	3.45	4.00	3.48	6.1/A++	2.79	2.79	3.71	3.71	-	2.60	13.00	13.00	1.61	3.20	4.00	4.06	4.0/A+	
25+25+35+50	2.25	2.25	3.00	4.50	-	2.40	12.00	13.60	2.60	3.45	4.00	3.48	6.1/A++	2.44	2.44	3.25	4.88	-	2.60	13.00	13.00	1.61	3.20	4.00	4.06	4.0/A+	
25+25+35+70	2.00	2.00	2.67	5.33	-	2.40	12.00	13.60	2.60	3.45	4.00	3.48	6.1/A++	2.17	2.17	2.89	5.78	-	2.60	13.00	13.00	1.61	3.20	4.00	4.06	4.0/A+	
25+25+50+50	2.00	2.00	4.00	4.00	-	2.40	12.00	13.60	2.60	3.45	4.00	3.48	6.1/A++	2.17	2.17	4.33	4.33	-	2.60	13.00	13.00	1.61	3.20	4.00	4.06	4.0/A+	
25+25+50+70	1.80	1.80	3.60	4.80	-	2.40	12.00	13.60	2.60	3.45	4.00	3.48	6.1/A++	1.95	1.95	3.90	5.20	-	2.60	13.00	13.00	1.61	3.20	4.00	4.06	4.0/A+	
25+35+35+35	2.40	3.20	3.20	3.20	-	2.40	12.00	13.60	2.60	3.45	4.00	3.48	6.1/A++	2.60	3.47	3.47	3.47	-	2.60	13.00	13.00	1.61	3.20	4.00	4.06	4.0/A+	
25+35+35+50	2.12	2.82	2.82	4.24	-	2.40	12.00	13.60	2.60	3.45	4.00	3.48	6.1/A++	2.29	3.06	3.06	4.59	-	2.60	13.00	13.00	1.61	3.20	4.00	4.06	4.0/A+	
25+35+35+70	1.89	2.53	2.53	5.05	-	2.40	12.00	13.60	2.60	3.45	4.00	3.48	6.1/A++	2.05	2.74	2.74	5.47	-	2.60	13.00	13.00	1.61	3.20	4.00	4.06	4.0/A+	
25+35+50+50	1.89	2.53	3.79	3.79	-	2.40	12.00	13.60	2.60	3.45	4.00	3.48	6.1/A++	2.05	2.74	4.11	4.11	-	2.60	13.00	13.00	1.61	3.20	4.00	4.06	4.0/A+	
25+35+50+70	1.71	2.29	3.43	4.57	-	2.40	12.00	13.60	2.60	3.45	4.00	3.48	6.1/A++	1.86	2.48	3.71	4.95	-	2.60	13.00	13.00	1.61	3.20	4.00	4.06	4.0/A+	
25+50+50+50	1.71	3.43	3.43	3.43	-	2.40	12.00	13.60	2.60	3.45	4.00	3.48	6.1/A++	1.86	3.71	3.71	3.71	-	2.60	13.00	13.00	1.61	3.20	4.00	4.06	4.0/A+	
35+35+35+35	3.00	3.00	3.00	3.00	-	2.40	12.00	13.60	2.60	3.45	4.00	3.48	6.1/A++	3.25	3.25	3.25	3.25	-	2.60	13.00	13.00	1.61	3.20	4.00	4.06	4.0/A+	
35+35+35+50	2.67	2.67	2.67	4.00	-	2.40	12.00	13.60	2.60	3.45	4.00	3.48	6.1/A++	2.89	2.89	2.89	4.33	-	2.60	13.00	13.00	1.61	3.20	4.00	4.06	4.0/A+	
35+35+35+70	2.40	2.40	2.40	4.80	-	2.40	12.00	13.60	2.60	3.45	4.00	3.48	6.1/A++	2.60	2.60	2.60	5.20	-	2.60	13.00	13.00	1.61	3.20	4.00	4.06	4.0/A+	
35+35+50+50	2.40	2.40	3.60	3.60	-	2.40	12.00	13.60	2.60	3.45	4.00	3.48	6.1/A++	2.60	2.60	3.90	3.90	-	2.60	13.00	13.00	1.61	3.20	4.00	4.06	4.0/A+	
22+22+22+22+22	2.10	2.10	2.10	2.10	2.10	2.40	10.50	11.34	2.60	3.45	4.00	3.04	6.1/A++	2.60	2.60	2.60	2.60	2.60	2.60	2.60	13.00	13.00	1.61	3.20	4.00	4.06	4.0/A+
22+22+22+22+25	2.10	2.10	2.10	2.10	2.60	2.40	11.00	11.88	2.60	3.45	4.00	3.19	6.1/A++	2.46	2.46	2.46	3.16	2.60	2.60	13.00	13.00	1.61	3.20	4.00	4.06	4.0/A+	
22+22+22+22+35	2.10	2.10	2.10	2.10	3.50	2.40	11.90	12.85	2.60	3.45	4.00	3.45	6.1/A++	2.28	2.28	2.28	2.28	3.90	2.60	13.00	13.00	1.61	3.20	4.00	4.06	4.0/A+	
22+22+22+22+50	1.83	1.83	1.83	1.83	4.70	2.40	12.00	13.60	2.60	3.45	4.00	3.48	6.1/A++	1.98	1.98	1.98	5.09	2.60	2.60	13.00	13.00	1.61	3.20	4.00	4.06	4.0/A+	
22+22+22+22+70	1.62	1.62	1.62	1.62	5.54	2.40	12.00	13.60	2.60	3.45	4.00	3.48	6.1/A++	1.75	1.75	1.75	6.00	2.60	2.60	13.00	13.00	1.61	3.20	4.00	4.06	4.0/A+	
22+22+22+25+25	2.10	2.10	2.10	2.60	2.60	2.40	11.50	12.42	2.60	3.45	4.00	3.33	6.1/A++	2.33	2.33	2.33	3.00	2.60	2.60	13.00	13.00	1.61	3.20	4.00	4.06	4.0/A+	
22+22+22+25+35	2.00	2.00	2.00	2.57	3.43	2.40	12.00	13.60	2.60	3.45	4.00	3.48	6.1/A++	2.17	2.17	2.17	2.79	3.71	2.60	13.00	13.00	1.61	3.20	4.00	4.06	4.0/A+	
22+22+22+25+50	1.75	1.75	1.75	2.25	4.50	2.40	12.00	13.60	2.60	3.45	4.00	3.48	6.1/A++	1.90	1.90	1.90	2.44	4.88	2.60	13.00	13.00	1.61	3.20	4.00	4.06	4.0/A+	
22+22+22+25+70	1.56	1.56	1.56	2.00	5.33	2.40	12.00	13.60	2.60	3.45	4.00	3.48	6.1/A++	1.69	1.69	1.69	2.17	5.78	2.60	13.00	13.00	1.61	3.20	4.00	4.06	4.0/A+	
22+22+22+35+35	1.87	1.87	1.87	3.20	3.20	2.40	12.00	13.60	2.60	3.45	4.00	3.48	6.1/A++	2.02	2.02	2.02	3.47	3.47	2.60	13.00	13.00	1.61	3.20	4.00	4.06	4.0/A+	
22+22+22+35+50	1.65	1.65	1.65	2.82	4.24	2.40	12.00	13.60	2.60	3.45	4.00	3.48	6.1/A++	1.78	1.78	1.78	3.06	4.59	2.60	13.00	13.00	1.61	3.20	4.00	4.06	4.0/A+	
22+22+22+35+70	1.47	1.47	1.47	2.53	5.05	2.40	12.00	13.60	2.60	3.45	4.00	3.48	6.1/A++	1.60	1.60	1.60	2.74	5.47	2.60	13.00	13.00	1.61	3.20	4.00	4.06	4.0/A+	
22+22+22+50+50	1.47	1.47	1.47	3.79	3.79	2.40	12.00	13.60	2.60	3.45	4.00	3.48	6.1/A++	1.60	1.60	1.60	4.11	2.60	13.00	13.00	1.61	3.20	4.00	4.06	4.0/A+		
22+22+22+50+70	1.33	1.33	1.33	3.43	4.57	2.40	12.00	13.60	2.60	3.45	4.00	3.48	6.1/A++	1.44	1.44	1.44	3.71	4.95	2.60	13.00	13.00	1.61	3.20	4.00	4.06	4.0/A+	
22+22+25+25+25	2.10	2.10	2.60	2.60	2.60	2.40	12.00	12.96	2.60	3.45	4.00	3.48	6.1/A++	2.22	2.22	2.85	2.85	2.60	13.00	13.00	1.61	3.20	4.00	4.06	4.0/A+		
22+22+25+25+35	1.91	1.91	2.45	2.45	3.27	2.40	12.00	13.60	2.60	3.45	4.00	3.48	6.1/A++	2.07	2.07	2.66	2.66	3.55	2.60	13.00	13.00	1.61	3.20	4.00	4.06	4.0/A+	
22+22+25+25+50	1.68	1.68	2.16	2.16	4.32	2.40	12.00	13.60	2.60	3.45	4.00	3.48	6.1/A++	1.82	1.82	2.34	2.34	4.68	2.60	13.00	13.00	1.61	3.20	4.00	4.06	4.0/A+	
22+22+25+25+70	1.50	1.50	1.93	1.93	5.14	2.40	12.00	13.60	2.60	3.45	4.00	3.48	6.1/A++	1.63	1.63	2.09	2.09	5.57	2.60	13.00	13.00	1.61	3.20	4.00	4.06	4.0/A+	
22+22+25+35+35	1.79	1.79	2.30	3.06	3.06	2.40	12.00	13.60	2.60	3.45	4.00	3.48	6.1/A++	1.94	1.94	2.49	3.32	3.32	2.60	13.00	13.00	1.61	3.20	4.00	4.06	4.0/A+	
22+22+25+35+50	1.58	1.58	2.04	2.72	4.08	2.40	12.00	13.60	2.60	3.45	4.00	3.48	6.1/A++	1.72	1.72	2.21	2.94	4.42	2.60	13.00	13.00	1.61	3.20	4.00	4.06	4.0/A+	
22+22+25+35+70	1.42	1.42	1.83	2.44	4.88	2.40	12.00	13.60	2.60	3.45	4.00	3.48	6.1/A++	1.54	1.54	1.98	2.64	5.29	2.60	13.00	1						



CONSOLE, FLOOR CEILING AND FLOOR STANDING *Ranges*

MODEL	REFRI- GERANT TYPE	9	12	18	24	36	48	60	kBTU/h kW
		2.5	3.5	5	7	10	12.5	16	
<p>p.86</p>  <p>XDLF R32</p> <p>DUAL-FLOW CONSOLE <i>Ideal solution for replacing electric radiators</i></p>	R32	•	•	•					
<p>p.88</p>  <p>XDMX R32</p> <p>DUAL-FLOW CONSOLE <i>Ideal solution for replacing electric radiators</i></p>	R32		•	•					
<p>p.90</p>  <p>FDMX R32</p> <p>FLOOR CEILING <i>High-range blowing</i></p>	R32			•	•	•	•	•	
<p>p.92</p>  <p>FDLK R32</p> <p>LOW-TEMPERATURE FLOOR CEILING <i>Solution for low-temperature rooms</i></p>	R32			•	•				
<p>p.94</p>  <p>SDMX R32</p> <p>FLOOR STANDING <i>Solution for high-volume halls</i></p>	R32						•		



DC Inverter
Reversible



HYBRID
HOUSE by Airwell



XDLF

Dual-flow console



RC08A
included

+ PRODUCT

- RC08A remote control included (see page 128)
- Wide range (9/12/18)
- Dual-flow air supply
- Operate down to -22°C
- Multisplit compatible
- Active charcoal filter

FEATURES

TECHNOLOGY



FLEXY MATCH



ELECTRONIC EXPANSION VALVE

AIR QUALITY/CLEAN



NANO PHOTOCATALYTIC FILTER



ANTIBACTERIAL FILTER

USER FUNCTIONS



I FEEL



NIGHT MODE



SUPER QUIET



PROGRAMMABLE TIMER



RESTART (MEMORY)



REMOTE CONTROL LOCK



WI-FI

INSTALLER FUNCTIONS



ERROR CODE VIA INDOOR UNIT



AUTO-DIAGNOSTIC

CERTIFICATION

- AIRWELL participates in the ECP programme for AC1. Check ongoing validity of certificate: www.eurovent-certification.com



- Certified in Monosplit configuration

+ "SUSTAINABLE DEVELOPMENT"

- > Operate down to -22°C.
- > Environment friendly R32 refrigerant.

+ "USER"

- > User-friendly ("I Feel", Wi-Fi).
- > Night mode.

+ "INSTALLER"

- > The best reliability on the market.

+ "TECHNOLOGY"

- > DC fan units.
- > Installer mode for direct reading of the probes on the indoor unit.
- > Technician mode for setting the operating temperatures.



AirHome connectivity

OPTIONS

ACCESSORY	PART NUMBER	PICTURE	FUNCTION
Wired remote control RCW27 (see page 138)	7ACEL1874		• Weekly programming, mode setting, temperature setting, fan speed, key lock.

See technical draws page 153

TECHNICAL DATA

MULTISPLIT
CONFIGURATION ONLY

XDLF

INDOOR UNIT		XDLF-025N-09M25	XDLF-035N-09M25	XDLF-050N-09M25
Part number		7SP071440	7SP071441	7SP071442
Phase		Single-phase	Single-phase	Single-phase

COOLING

Rated power (min./max.)	kW	2.70 (0.7-3.4)	3.50 (0.8-4.4)	5.20 (1.3-6.6)
Pdesignc	kW	-	3.50	5.20
Rated power input	kW	-	1.00	1.55
SEER/Energy label		-	7.0/A++	6.6/A++
Operating limits	°C	-	-15°/43° Dry bulb	

HEATING

Rated power (min./max.)	kW	2.90 (0.6-3.5)	3.80 (1.1-4.4)	5.33 (1.12-6.8)
Pdesignh (average climate)	kW	-	3.20	5.00
Pdesignh (warmer climate)	kW	-	3.30	5.00
Rated power input	kW	-	0.96	1.50
SCOP/Energy label (average climate)		-	4.1/A+	4.1/A+
SCOP/Energy label (warmer climate)		-	5.3/A+++	5.1/A+++
Operating limits	°C	-	-22°/24° Dry bulb	
Power at -10 °C	kW	-	3.34	4.69
Power at -15 °C	kW	-	2.28	3.20

INDOOR UNIT

Sound pressure level at 1 m (VL/LS/MS/HS)	dB(A)	23/26/33/39	25/29/38/44	32/37/43/47
Sound level	dB(A)	34/38/45/50	35/39/48/54	42/47/53/57
Airflow (VL/LS/MS/HS)	m³/h	250/280/410/500	280/360/480/600	320/410/580/700
Dehumidification	l/h	0.80	1.20	1.80
Outline dimensions (WxHxD)	mm	700x600x215	700x600x215	700x600x215
Package dimensions (WxHxD)	mm	788x685x295	788x685x295	788x685x295
Net weight/Gross weight	kg	15.5/18.5	15.5/18.5	15.5/18.5

OUTDOOR UNIT		-	YDAF-035R-09M25	YDAF-050R-09M25
Part number		-	7SP063205	7SP063206
Sound pressure level at 1 m	dB(A)	-	52	57
Sound level	dB(A)	-	62	65
Airflow	m³/h	-	2200	3200
Compressor type		-	Rotary DCI	Rotary DCI
Outline dimensions (WxHxD)	mm	-	848x596x320	965x700x396
Package dimensions (WxHxD)	mm	-	881x645x363	1029x750x458
Net weight/Gross weight	kg	-	30.5/33.5	46/50.5

POWER SUPPLY



Phase/Voltage/Frequency		1P/220-240V/50Hz	1P/220-240V/50Hz	1P/220-240V/50Hz
Power supply side		Outdoor	Outdoor	Outdoor
Power cable section	mm²	-	3x1.5	3x1.5
Fuse rating am (D curve)	A	-	16	16
Electrical connections	mm²	4x1.5	4x1.5	4x1.5

PIPE LINE

Suction pipe diameter	inches	3/8"	3/8"	1/2"
Liquid pipe diameter	inches	1/4"	1/4"	1/4"
Max. length	m	-	20	25
Max. height	m	-	10	10
Refrigerant/GWP		-	R32/675	R32/675
Charge (5m)	kg	-	0.75	0.95
Additional charge	g/m	-	16	16

Warning: Unit not suitable for wet rooms such as bathrooms, kitchens, laundry rooms.

MATCHING

INDOOR UNIT	COMPATIBLE WITH OUTDOOR UNIT
CONSOLE	MULTISPLIT
	
XDLF 025	ZDAE

MATCHING

INDOOR UNIT	COMPATIBLE WITH OUTDOOR UNIT	
CONSOLE	MONOSPLIT	MULTISPLIT
		
XDLF 035 & 050	YDAF	ZDAE



DC Inverter
Reversible



HYBRID
HOUSE by Airwell



XDMX

Dual-flow console



RC18
included

+ PRODUCT

- RC18 remote control included (see page 130)
- Design
- Performance
- Quiet
- Compatible with ZDAA multisplit

FEATURES

TECHNOLOGY



FLEXY MATCH



ELECTRONIC EXPANSION VALVE



GOLDEN FIN TREATMENT

AIR QUALITY/CLEAN



ANTIBACTERIAL FILTER

USER FUNCTIONS



I FEEL



NIGHT MODE



24 H PROGRAMMABLE TIMER



RESTART (MEMORY)



Wi-Fi

INSTALLER FUNCTIONS



HEATING ONLY MODE

CERTIFICATION

- AIRWELL participates in the ECP programme for AC1. Check ongoing validity of certificate: www.eurovent-certification.com



- Certified in Monosplit configuration

+ “SUSTAINABLE DEVELOPMENT”

- > High seasonal performance (SEER/SCOP).
- > Energy label A++ in cooling mode and A+ in heating mode depending model, guaranteeing energy savings.
- > Environment friendly R32 refrigerant.

+ “USER”

- > Contemporary design to fit any interior.
- > Multi-directional air louvers for air distribution throughout the room.
- > Wi-Fi included for remote control of the unit.
- > Low noise level ideal for living rooms (bedroom, office, living room, etc.).

+ “INSTALLER”

- > Room sensor built into the remote control for better comfort (“I Feel” mode).
- > Automatic cleaning of heat exchangers for better hygiene and performance.
- > Golden Fin treatment on the heat exchangers (external and internal) for protection against corrosion and durability over time.

+ “TECHNOLOGY”

- > Installer mode for direct reading of the probes on the indoor unit.
- > Technician mode for setting the operating temperatures.



See technical draws page 154

TECHNICAL DATA

XDMX

INDOOR UNIT		XDMX-035N-09M25	XDMX-050N-09M25
Part number		7SP071435	7SP071436
Phase		Single-phase	Single-phase
COOLING			
Rated power (min./max.)	kW	3.52 (0.76~4.25)	4.98 (2.64~5.57)
Pdesignc	kW	3.50	5.00
Rated power input	kW	1.00	1.50
SEER/Energy label		7.3/A++	6.7/A++
Operating limits	°C	-15°/50° Dry bulb	
HEATING			
Rated power (min./max.)	kW	3.81 (0.45~4.69)	5.28 (2.20~6.30)
Pdesignh (average climate)	kW	2.60	4.00
Pdesignh (warmer climate)	kW	3.40	5.00
Rated power input	kW	0.98	1.42
SCOP/Energy label (average climate)		4.0/A+	4.0/A+
SCOP/Energy label (warmer climate)		5.5/A+++	5.0/A++
Operating limits	°C	-15°/24° Dry bulb	
Power at -7°C	kW	3.18	4.86
Power at -10°C	kW	3.04	4.64
Power at -15°C	kW	2.85	4.35
INDOOR UNIT			
Sound pressure level at 1 m (LS/MS/HS)	dB(A)	27/34/37	32/38/41
Sound level	dB(A)	54	55
Airflow (LS/MS/HS)	m³/h	490/580/650	600/690/780
Dehumidification	l/h	1.2	1.8
Outline dimensions (WxHxD)	mm	794x621x200	794x621x200
Package dimensions (WxHxD)	mm	865x280x719	865x280x719
Net weight/Gross weight	kg	14.9/18.8	14.9/18.8

OUTDOOR UNIT		YDAX-035H-09M25	YDAX-050H-09M25
Part number		7SP063170	7SP063171
Sound pressure level at 1 m	dB(A)	51	52
Sound level	dB(A)	62	63
Airflow	m³/h	2200	2100
Compressor type		Rotary DCI	Rotary DCI
Outline dimensions (WxHxD)	mm	765x555x303	805x554x330
Package dimensions (WxHxD)	mm	887x610x337	915x615x370
Net weight/Gross weight	kg	26.6/29.4	32.5/35.3

POWER SUPPLY			
Phase/Voltage/Frequency		1P/220-240V/50Hz	1P/220-240V/50Hz
Power supply side		Outdoor	Outdoor
Power cable section	mm²	3G1.5	3G1.5
Fuse rating am	A	16	16
Electrical connections in/out	mm²	4G1.5	4G1.5

PIPE LINE			
Suction pipe diameter	inches	3/8"	1/2"
Liquid pipe diameter	inches	1/4"	1/4"
Max. length	m	25	30
Max. height	m	10	20
Refrigerant/GWP			
Charge (5m)	kg	0.71	1.15
Additional charge	g/m	12	12

Warning: Unit not suitable for wet rooms such as bathrooms, kitchens, laundry rooms.

MATCHING

INDOOR UNIT	COMPATIBLE WITH OUTDOOR UNIT	
	MONOSPLIT	MULTISPLIT
 XDMX	 YDAX	 ZDAA

Console
Floor ceiling
Floor standing



DC Inverter
Reversible



FDMX

Floor ceiling



RC18
included

+ PRODUCT

- RC18 remote control included (see page 130)
- Floor or ceiling installation
- Slim
- Long distance air throw
- Compatible with YDZC and ZDAA multisplits

FEATURES

TECHNOLOGY



FLEXY MATCH



ELECTRONIC EXPANSION VALVE



GOLDEN FIN TREATMENT

AIR QUALITY/CLEAN



ANTIBACTERIAL FILTER

USER FUNCTIONS



TIMER



I FEEL



NIGHT MODE



RESTART

AUTO RESTART (MEMORY)

CERTIFICATION

- AIRWELL participates in the ECP programme for AC1. Check ongoing validity of certificate: www.eurovent-certification.com



- Models marked * are not Eurovent certified

+ “SUSTAINABLE DEVELOPMENT”

- > Energy label A++ in cooling mode and A+ in heating mode depending on model, guaranteeing energy savings.

+ “USER”

- > Discreet thanks to its small depth (235 mm).
- > Wall or ceiling installation, ideal to suit the room configuration.

+ “INSTALLER”

- > Parameter reading.
- > Air louvers optimized for blowing up to 11 m.
- > Maximum piping length up to 75m adapted to complex and remote installation.

+ “TECHNOLOGY”

- > Multi-directional air louvers for air distribution throughout the room.
- > Room sensor built into the remote control for better comfort (“I Feel” mode by pressing the TURBO button on the remote control for 7 s).
- > On/Off contact included associated with a “room card” or other solution (not supplied) for better control and for energy savings.
- > Alarm contact (synthesis fault) included.
- > Golden Fin treatment on the heat exchangers (external and internal) for protection against corrosion and durability over time.
- > Wide operating range of -15° to 50°C in cooling mode and -15° to 24°C in heating mode.



With LCAC
Wi-Fi solar
panel in
optional

AirHome connectivity

OPTIONS

ACCESSORY	PART NUMBER	PICTURE	FUNCTION
Wired remote control RCW11 (see page 134)	7ACEL1774		• Weekly timer, mode, fan speed, On/Off timer, “I Feel” function, temperature.
Wired remote control RCW26 (see page 136)	7ACEL1876		• Controls until 16 indoor units.
Condensate pump Mini Flowwatch MF2	7ACTL0517		• Condensate evacuation from indoor units.
LCAC Wi-Fi accessory	7ACEL1883		• Accessory for remote control via Wi-Fi.

See technical draws page 154

TECHNICAL DATA

FDMX

INDOOR UNIT		FDMX-050N-09M25	FDMX-070N-09M25	FDMX-100N-09M25	FDMX-100N-09M25	FDMX-140N-09M25*	FDMX-175N-09M25*
Part number		7SP012300	7SP012301	7SP012302	7SP012302	7SP012303	7SP012304
Phase		Single-phase	Single-phase	Single-phase	Three-phase	Three-phase	Three-phase
COOLING							
Rated power (min./max.)	kW	5.28 (2.71~5.86)	7.03 (3.22~7.77)	10.55 (2.73~11.43)	10.55 (2.73~11.78)	14.07 (3.52~15.24)	15.83 (4.10~16.71)
Pdesignc	kW	5.40	7.20	10.50	10.50	14.00	15.50
Rated power input	kW	1.45	2.30	3.90	4.00	5.00	5.65
SEER/Energy label		6.2/A++	6.1/A++	6.4/A++	6.2/A++	6.1/A++	6.1/A++
Operating limits	°C	-15°~50°C Dry bulb					
HEATING							
Rated power (min./max.)	kW	5.57 (2.42~6.30)	7.62 (2.72~8.29)	11.72 (2.78~12.78)	11.72 (2.81~12.78)	16.12 (4.10~17.00)	18.17 (4.40~19.64)
Pdesignh (average climate)	kW	4.00	5.50	8.60	8.60	11.20	11.90
Pdesignh (warmer climate)	kW	5.10	5.80	10.20	10.00	11.70	12.60
Rated power input	kW	1.50	2.05	3.35	3.35	5.10	6.05
SCOP/Energy label (average climate)		4.0/A+	4.0/A+	4.1/A+	4.0/A+	3.9/A	4.0/A+
SCOP/Energy label (warmer climate)		5.1/A+++	5.1/A+++	5.1/A+++	5.1/A+++	5.1/A+++	5.1/A+++
Operating limits	°C	-15°~24°C Dry bulb					
Power at -7°C	kW	4.30	5.94	9.21	9.08	11.76	12.76
Power at -10°C	kW	4.11	5.67	8.79	8.67	11.23	12.18
Power at -15°C	kW	3.85	5.31	8.23	8.12	10.51	11.41
INDOOR UNIT							
Sound pressure level at 1 m (LS/MS/HS)	dB(A)	37/41/44	43/47/51	45/48/51.5	45/47.5/51	46/50/53	48/52/55
Sound level	dB(A)	59	55	65	65	67	67
Airflow (LS/MS/HS)	m³/h	723/839/958	853/1023/1192	1504/1728/1955	1504/1728/1955	1600/1850/2100	1650/1950/2200
Dehumidification	l/h	1.80	2.40	3.60	3.60	4.80	5.50
Outline dimensions (WxHxD)	mm	1068x675x235	1068x675x235	1650x675x235	1650x675x235	1650x675x235	1650x675x235
Package dimensions (WxHxD)	mm	1145x755x318	1145x755x318	1725x755x318	1725x755x318	1725x755x318	1725x755x318
Net weight/Gross weight	kg	28/33.4	28/33.2	41.5/48.1	41.5/48.1	41.7/48.6	42.3/49.3

OUTDOOR UNIT		YDAX-050H-09M25	YDAX-070H-09M25	YDAX-100H-09M25	YDAX-100H-09T35	YDAX-140H-09T35	YDAX-175H-09T35
Part number		7SP063171	7SP063172	7SP063173	7SP063174	7SP063175	7SP063176
Sound pressure level at 1 m	dB(A)	54	56	59	59	63	62
Sound level	dB(A)	65	67	70	74	74	73
Airflow	m³/h	2100	3500	4000	4000	7500	7500
Compressor type		Rotary	Rotary	Rotary	Rotary	Rotary	Rotary
Outline dimensions (WxHxD)	mm	805x554x330	890x673x342	946x810x410	946x810x410	952x1333x415	952x1333x415
Package dimensions (WxHxD)	mm	915x615x370	995x740x398	1090x885x500	1090x885x500	1095x1480x495	1095x1480x495
Net weight/Gross weight	kg	32.5/35.3	43.9/46.7	66.9/72.1	75.5/85.6	103.7/118.3	107.0/121.2

POWER SUPPLY							
Phase/Voltage/Frequency		1P/220-240V/50Hz	1P/220-240V/50Hz	1P/220-240V/50Hz	3P/380-415V/50Hz	3P/380-415V/50Hz	3P/380-415V/50Hz
Power supply side		Outdoor	Outdoor	Outdoor	Outdoor	Outdoor	Outdoor
Power cable section	mm²	3G1.5	3G2.5	3G4.0	5G2.5	5G2.5	5G2.5
Fuse rating am	A	16	20	25	16	16	16
Electrical connections in/out	mm²	4G1.5	4G1.5	4G1.5	4G1.5	4G1.5	4G1.5

PIPE LINE							
Suction pipe diameter	inches	1/2"	5/8"	5/8"	5/8"	5/8"	5/8"
Liquid pipe diameter	inches	1/4"	3/8"	3/8"	3/8"	3/8"	3/8"
Max. length	m	30	50	75	75	75	75
Max. height	m	20	25	30	30	30	30
Refrigerant/GWP		R32/675	R32/675	R32/675	R32/675	R32/675	R32/675
Charge (5 m)	kg	1.15	1.50	2.40	2.40	2.90	3.00
Additional charge	g/m	12	24	24	24	24	24

MATCHING

INDOOR UNIT
FLOOR CEILING

FDMX 050N & 070N

FDMX 100N to 175N



COMPATIBLE WITH OUTDOOR UNIT		
MONOSPLIT	MULTISPLIT	
		
YDAX	ZDAA	YDZC
		
YDAX		

Console
Floor ceiling
Floor standing



DC Inverter
Cooling only



FDLK

Low-temperature floor ceiling



RCW25
included

+ PRODUCT

- RCW25 remote control included
- Minimum temperature setpoint of 12 °C
- Robust and tough: metal structure

FEATURES

TECHNOLOGY



ELECTRONIC EXPANSION VALVE

AIR QUALITY/CLEAN



FRESH AIR

USER FUNCTIONS



I FEEL



NIGHT MODE



PROGRAMMABLE TIMER



AUTO RESTART (MEMORY)



REMOTE CONTROL LOCK

INSTALLER FUNCTIONS



ERROR CODE VIA INDOOR UNIT



AUTO-DIAGNOSTIC



LEFT/RIGHT CONDENSATE CONNECTION



ALARM OUTPUT



DRY CONTACT ON/OFF



TECHNICIAN TEST MODE

+ “SUSTAINABLE DEVELOPMENT”

- > High energy label A++.

+ “USER”

- > Dedicated solution for low-temperature rooms (wine cellars, preparation rooms, household waste areas, etc.).
- > The indoor unit is more compact and lighter than the previous version, allowing it to be easily built-in even in small spaces.
- > With an optimized air flow rate, the temperature set point can be achieved more quickly.

+ “INSTALLER”

- > Ease of installation

+ “TECHNOLOGY”

- > Oversized exchangers (no frosting).

OPTIONS

ACCESSORY	PART NUMBER	PICTURE	FUNCTION
Condensate pump Mini Flowwatch MF2	7ACTL0517		• Condensate evacuation from indoor units.

See technical draws page 155

Dedicated for any low-temperature process rooms

- > Minimum temperature setpoint 12 °C



TECHNICAL DATA

FDLK

INDOOR UNIT		FDLK-050N-09M25	FDLK-070N-09M25
Part number		7SP012315	7SP012316
Phase		Single-phase	Single-phase

COOLING

Rated power (min./max.)	kW	5.30 (2.00-5.60)	7.00 (3.50-8.00)
Pdesignc	kW	5.30	7.10
Rated power input	kW	1.49	2.09
SEER/Energy label		6.1/A++	6.1/A++
Operating limits	°C	-15°/50° Dry bulb	

INDOOR UNIT

Sound pressure level at 1 m (LS/MS/HS)	dB(A)	36/42/47	36/42/47
Sound level	dB(A)	52	52
Airflow (LS/MS/HS)	m³/h	900/1050/1200	900/1050/1200
Dehumidification	l/h	1.80	2.40
Outline dimensions (WxHxD)	mm	1050x675x235	1050x675x235
Package dimensions (WxHxD)	mm	1130x765x330	1130x765x330
Net weight/Gross weight	kg	26.5/31	26.5/31

OUTDOOR UNIT		YDAK-050R-09M25	YDAK-070R-09M25
Part number		7SP063195	7SP063196
Sound pressure level at 1 m	dB(A)	52	54
Sound level	dB(A)	66	68
Airflow	m³/h	1950	3200
Compressor type		Rotary DCI	Twin Rotary DCI
Outline dimensions (WxHxD)	mm	880x555x345	935x702x382
Package dimensions (WxHxD)	mm	920x600x380	975x770x435
Net weight/Gross weight	kg	32.5/35	48.7/52.6

POWER SUPPLY

Phase/Voltage/Frequency		1P/230V/50Hz	1P/230V/50Hz
Power supply side		Outdoor	Outdoor
Power cable section	mm²	3G2.5	3G2.5
Fuse rating am	A	20	20
Electrical connections in/out	mm²	4G1.5	4G1.5

PIPE LINE

Suction pipe diameter	inches	1/2"	5/8"
Liquid pipe diameter	inches	1/4"	3/8"
Max. length	m	15	20
Max. height	m	8	10
Refrigerant/GWP		R32/675	R32/675
Charge	kg	1.20	1.45
Additional charge	g/m	12	24

MATCHING



Console
Floor ceiling
Floor standing



DC Inverter
Reversible



SDMX

Floor standing

+ PRODUCT

- RC19 remote control included (see page 132)
- Long distance air throw
- High airflow (2413 m³/h)
- Inverter solution

FEATURES

TECHNOLOGY



ELECTRONIC
EXPANSION VALVE



GOLDEN FIN
TREATMENT

AIR QUALITY/CLEAN



ANTIBACTERIAL
FILTER

USER FUNCTIONS



TIMER



I FEEL



AUTO RESTART
(MEMORY)

INSTALLER FUNCTIONS



ERROR CODE VIA
INDOOR UNIT



RC19
included

+ “SUSTAINABLE DEVELOPMENT”

- > Energy label A++ in cooling mode and A+ in heating mode, guaranteeing energy savings.
- > Environment friendly R32 refrigerant.

+ “USER”

- > Solution suitable for large spaces.
- > Controlled by infrared remote control.

+ “TECHNOLOGY”

- > Room sensor built into the remote control for better comfort (“I Feel” mode).
- > Golden Fin treatment on the heat exchangers (external and internal) for protection against corrosion and durability over time.

See technical draws page 156

TECHNICAL DATA

SDMX

INDOOR UNIT		SDMX-140N-09M35
Part number		7SP101060
Phase		Three-phase
COOLING		
Rated power (min./max.)	kW	14.07 (3.51-15.64)
Rated power input	kW	4.95
SEER/Energy label		6.1/A++
Operating limits	°C	-15°~50°C Dry bulb
HEATING		
Rated power (min./max.)	kW	16.12 (4.92-17.83)
Pdesignh (average climate)	kW	11.10
Pdesignh (warmer climate)	kW	11.00
Rated power input	kW	5.10
SCOP/Energy label (average climate)		4.0/A+
SCOP/Energy label (warmer climate)		5.1/A+++
Power at -7°C	kW	14.89
Power at -10°C	kW	14.22
Power at -15°C	kW	13.31
Operating limits	°C	-15°~24°C Dry bulb
INDOOR UNIT		
Sound pressure level at 1.5 m	dB(A)	55
Sound level	dB(A)	67
Airflow (LS/MS/HS)	m³/h	2027/2222/2413
Dehumidification	l/h	4.80
Outline dimensions (WxHxD)	mm	629x1935x456
Package dimensions (WxHxD)	mm	750x2055x575
Net weight/Gross weight	kg	59.0/77.0

OUTDOOR UNIT		YDAX-140H-09T35
Part number		7SP063175
Sound pressure level at 1 m	dB(A)	62
Sound level	dB(A)	73
Airflow	m³/h	7500
Compressor type		Rotary
Outline dimensions (WxHxD)	mm	952x1333x415
Package dimensions (WxHxD)	mm	1095x1480x495
Net weight/Gross weight	kg	103.7/118.3
POWER SUPPLY		
Phase/Voltage/Frequency		3P/380-415V/50Hz
Power supply side		Outdoor
Power cable section	mm²	5C2.5
Fuse rating am	A	16
Electrical connections in/out	mm²	4C1.5
PIPE LINE		
Suction pipe diameter	inches	5/8"
Liquid pipe diameter	inches	3/8"
Max. length	m	65
Max. height	m	30
Refrigerant/GWP		R32/675
Charge (5m)	kg	2.80

MATCHING

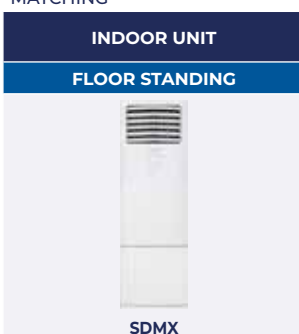

Console
Floor ceiling
Floor standing

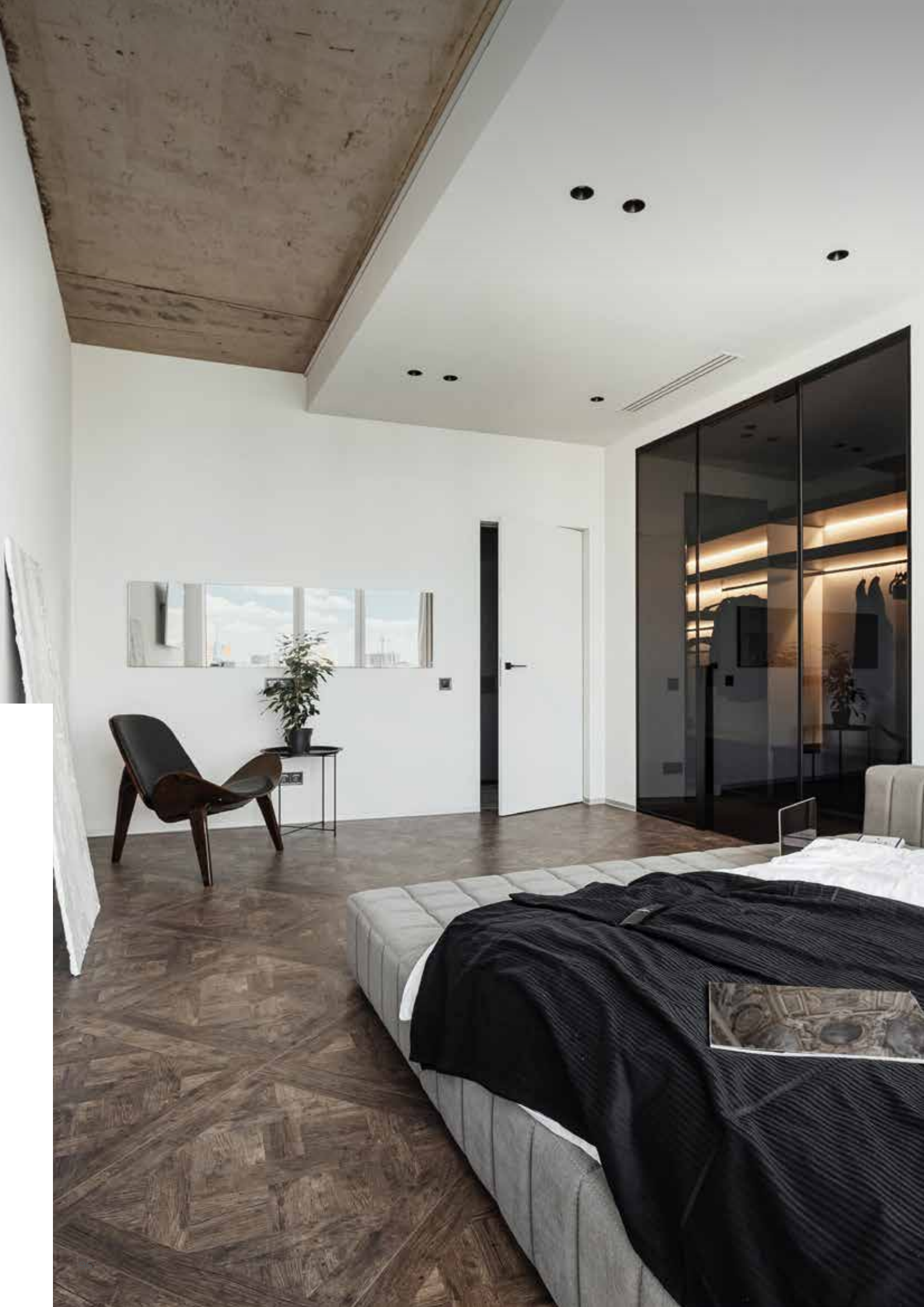

DUCTED

Range

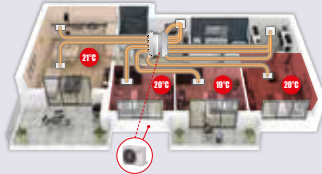

	MODEL	REFRI-GERANT TYPE	7 2	12 3.5	18 5	24 7	36 10	48 14	60 17	kBTU/h kW
p.98	 <p>DDMX R32</p> <p>MEDIUM-PRESSURE DUCTED <i>Designed to fit into tight false ceiling</i></p>	R32	•	•	•	•	•	•	•	
p.100	 <p>WELLZONE</p> <p>ZONE-BY-ZONE REGULATION <i>Ideal temperature in each room</i></p>					•				



DC Inverter
Reversible



HYBRID
HOUSE by Airwell



DDMX

Medium-pressure ducted



DDMX 022N-035N



RCW11 included



DDMX 050N-175N



+ PRODUCT

- RCW11 remote control included (see page 134)
- Discreet
- Compact
- Performance
- Compatible with YDZC and ZDAA multisplits
- Airzone compatible

FEATURES

TECHNOLOGY



FLEXY MATCH



ELECTRONIC EXPANSION VALVE



GOLDEN FIN TREATMENT

AIR QUALITY/CLEAN



ANTIBACTERIAL FILTER



FRESH AIR

USER FUNCTIONS



PROGRAMMABLE TIMER



I FEEL



NIGHT MODE



AUTO RESTART (MEMORY)

CERTIFICATION

- AIRWELL participates in the ECP programme for AC1. Check ongoing validity of certificate: www.eurovent-certification.com



- Models marked * are not Eurovent certified

+ “SUSTAINABLE DEVELOPMENT”

- > Energy label A++ in cooling mode and A+ in heating mode, guaranteeing energy savings.

+ “USER”

- > Invisible solution that can adapt to all types of interiors.
- > Wide range adapted to your needs.
- > Quiet due to its installation in a false ceiling.

+ “INSTALLER”

- > Compact design, ideal for tight spaces.
- > Static pressure (160 Pa) suitable for long duct lengths.
- > Unit with pre-drilled holes for fresh air supply to the room.
- > Maximum piping length up to 75m adapted to complex and remote installation.

+ “TECHNOLOGY”

- > On/Off contact included associated with a “room card” or other solution (not supplied) for better control and for energy savings.
- > Alarm contact (synthesis fault) included.
- > Room sensor built into the remote control for better comfort (“I Feel” mode by pressing the TURBO button on the remote control for 7 s).
- > Condensate pump included for automatic discharge.
- > Golden Fin treatment on the heat exchangers (external and internal) for protection against corrosion and durability over time.
- > Wide operating range of -15° to 50°C in cooling mode and -15° to 24°C in heating mode.

OPTIONS

ACCESSORY	PART NUMBER	PICTURE	FUNCTION
Wireless controller RC18 (see page 130)	7ACEL1898		• Fan speed mode, On/Off timer, “I Feel” function, technician test mode.
Wired remote control RCW26 (see page 136)	7ACEL1876		• Controls until 16 indoor units.
LCAC Wi-Fi accessory	7ACEL1883		• Accessory for remote control via Wi-Fi.
Insulated air duct plenum	7ACVF0136		• 3 ducts DN160. For DDMX 50.
	7ACVF0137		• 3 ducts DN160. For DDMX 70.
	7ACVF0138		• 3 ducts DN160. For DDMX 90-100.
	7ACVF0139		• 3 ducts DN160. For DDMX 140-175.

See technical draws page 157

TECHNICAL DATA

DDMX

		NEW				NEW				
INDOOR UNIT		DDMX-022N-09M25	DDMX-035N-09M25	DDMX-050N-09M25	DDMX-070N-09M25	DDMX-090N-09M25	DDMX-100N-09M25	DDMX-100N-09M25	DDMX-140N-09M25*	DDMX-175N-09M25*
Part number		7SP033069	7SP033070	7SP033071	7SP033072	7SP033076	7SP033073	7SP033073	7SP033074	7SP033075
Phase		Single-phase	Single-phase	Single-phase	Single-phase	Single-phase	Single-phase	Single-phase	Three-phase	Three-phase
COOLING										
Rated power (min./max.)	kW	2.05 (0.31~2.33)	3.52 (0.53~3.99)	5.28 (2.55~5.86)	7.03 (3.28~8.16)	8.79 (2.23~9.85)	10.55 (2.75~11.14)	10.55 (2.75~11.14)	14.07 (3.52~15.53)	15.24 (4.10~17.29)
Pdesignc	kW		3.50	5.40	7.10	8.8	10.50	10.60	14.00	15.30
Rated power input	kW		1.05	1.53	2.19	2.5	3.95	4.00	4.80	5.25
SEER/Energy label			6.3/A++	6.5/A++	6.2/A++	6.5/A++	6.2/A++	6.1/A++	6.1/A++	6.1/A++
Operating limits	°C		-15°~50°C Dry bulb							
HEATING										
Rated power (min./max.)	kW	2.34 (0.62~2.70)	3.81 (1.00~4.39)	5.57 (2.20~6.15)	7.62 (2.81~8.49)	9.38 (2.70~10.02)	11.72 (2.78~12.78)	11.72 (2.78~12.84)	16.12 (4.10~18.17)	18.17 (4.40~20.52)
Pdesignh (average climate)	kW		2.70	4.30	5.40	8	8.40	8.80	8.80	12.50
Pdesignh (warmer climate)	kW		3.40	5.20	6.00	8.20	9.80	10.00	11.50	12.80
Rated power input	kW		1.04	1.51	1.90	2.25	3.25	3.25	4.50	5.15
SCOP/Energy label (average climate)			4.0/A+	4.0/A+	4.0/A+	4.0/A+	4.0/A+	4.0/A+	4.0/A+	4.0/A+
SCOP/Energy label (warmer climate)			5.1/A+++	5.1/A+++	5.1/A+++	5.1/A+++	5.1/A+++	5.1/A+++	5.0/A++	5.1/A+++
Operating limits	°C		-15°~24°C Dry bulb							
Power at -7°C	kW		2.98	4.45	6.13	6.46	9.11	9.18	12.89	13.27
Power at -10°C	kW		2.85	4.25	5.85	6.16	8.69	8.76	12.31	12.67
Power at -15°C	kW		2.67	3.98	5.48	5.77	8.14	8.21	11.53	11.86
INDOOR UNIT										
Sound pressure level at 1 m (LS/MS/HS)	dB(A)	23/27/34/40	23/29/30/34	23/29/30/34	27/37/42/40	40.5/46/48/50.5	42/46/48/49	42/46/48/49	42/47/49/50	47/49/52
Sound level	dB(A)	58	58	58	62	63	61	61	66	66
Airflow (LS/MS/HS)	m³/h	230/340/500	300/480/600	515.2/706/911	825.1/1035/1229	1500/1800/2100	1500/1800/2100	1500/1800/2100	1680/2040/2400	1820/2210/2600
External static pressure (standard/max.)	Pa	25/0-40	25/0-60	25/0-100	25/0-160	37/0-160	37/0-160	37/0-160	50/0-160	50/0-160
Dehumidification	l/h	0.70	1.20	1.80	2.40	3.00	3.60	3.60	4.80	5.50
Outline dimensions (WxHxD)	mm	700x200x506	700x200x506	880x210x674	1100x249x774	1360x249x774	1360x249x774	1360x249x774	1200x300x874	1200x300x874
Package dimensions (WxHxD)	mm	860x285x540	860x285x540	1070x280x725	1305x315x805	1570x300x805	1570x300x805	1570x330x805	1405x365x915	1405x365x915
Net weight/Gross weight	kg	17.8/25.2	17.8/25.2	24.4/30.4	32.3/39.7	40.5/48.3	40.5/48.9	40.5/48.9	47.6/56.5	47.4/56.8
OUTDOOR UNIT										
		-	YDAX-035H-09M25	YDAX-050H-09M25	YDAX-070H-09M25	YDAX-090H-09M25	YDAX-100H-09M25	YDAX-100H-09T35	YDAX-140H-09T35	YDAX-175H-09T35
Part number		-	7SP063170	7SP063171	7SP063172	7SP063177	7SP063173	7SP063174	7SP063175	7SP063176
Sound pressure level at 1 m	dB(A)		51	54	57	59	59	59	63	63
Sound level	dB(A)		62	65	68	70	70	70	74	74
Airflow	m³/h		2200	2100	3500	3800	4000	4000	7500	7500
Compressor type			Rotary	Rotary	Rotary	Rotary	Rotary	Rotary	Rotary	Rotary
Outline dimensions (WxHxD)	mm		765x555x303	805x554x330	890x673x342	946x810x410	946x810x410	946x810x410	952x1333x415	952x1333x415
Package dimensions (WxHxD)	mm		887x610x337	915x615x370	995x740x398	1090x885x500	1090x885x500	1090x885x500	1095x1480x495	1095x1480x495
Net weight/Gross weight	kg		26.6/29.4	32.5/35.3	43.9/46.7	52.8/57.3	66.9/72.1	75.5/85.6	103.7/118.3	107.0/121.2
POWER SUPPLY										
Phase/Voltage/Frequency		1P/220-240V/50Hz	1P/220-240V/50Hz	1P/220-240V/50Hz	1P/220-240V/50Hz	1P/220-240V/50Hz	1P/220-240V/50Hz	3P/380-415V/50Hz	3P/380-415V/50Hz	3P/380-415V/50Hz
Power supply side			Outdoor	Outdoor	Outdoor	Outdoor	Outdoor	Outdoor	Outdoor	Outdoor
Power cable section	mm²		3G1.5	3G1.5	3G2.5	3G4.0	3G4.0	5G2.5	5G2.5	5G2.5
Fuse rating am	A		16	16	20	25	25	16	16	16
Electrical connections in/out	mm²	4G1.5	4G1.5	4G1.5	4G1.5	4G1.5	4G1.5	4G1.5	4G1.5	4G1.5
PIPE LINE										
Suction pipe diameter	inches	3/8"	3/8"	1/2"	5/8"	5/8"	5/8"	5/8"	5/8"	5/8"
Liquid pipe diameter	inches	1/4"	1/4"	1/4"	3/8"	3/8"	3/8"	3/8"	3/8"	3/8"
Max. length	m		25	30	50	50	75	75	75	75
Max. height	m		10	20	25	25	30	30	30	30
Refrigerant/GWP			R32/675	R32/675	R32/675	R32/675	R32/675	R32/675	R32/675	R32/675
Charge (5 m)	kg		0.72	1.15	1.50	2.00	2.40	2.40	2.90	3.00
Additional charge	g/m		12	12	24	24	24	24	24	24

Ducted

MATCHING

INDOOR UNIT	COMPATIBLE WITH OUTDOOR UNIT			
	DUCTED		MONOSPLIT	
 DDMX 022N			 ZDAA	 YDZC
 DDMX 035N-050N-070N	 YDAX	 ZDAA	 YDZC	

MATCHING

INDOOR UNIT	COMPATIBLE WITH OUTDOOR UNIT
	DUCTED
 DDMX 90N-100N	 YDAX
 DDMX 140N & 175N	 YDAX

WELLZONE:
*ideal temperature
in each room*

This solution works with
the ducted DDMX*.

- ▶ Air/air heat pump: **control up to 6 zones** in heating and cooling mode.
- ▶ The air louvers change their position (from 0 to 100%) in accordance with the thermostat (temperature set point) of each room, which **maintains the desired comfort temperature**.
- ▶ Each zone has an **independent remote control** equipped with the "I Feel" system, used to control the ambient temperature and the air louvers.
- ▶ **Invisible** HVAC solution for the whole house.
- ▶ **Cost saving** system (1 single indoor unit).

OPTION 1: YOUR ALL INCLUDEDIVE SOLUTION

REFERENCE	DESCRIPTION	COMPATIBILITY	PART NUMBER
1 WELLZONE 3V	• Control up to 3 zones	DDMX 35-50	7ACEL1805
2 WELLZONE 4V	• Control up to 4 zones	DDMX 35-50	7ACEL1806
3 WELLZONE 4V-5S	• Control up to 4 zones with 5 outputs	DDMX 70-175	7ACEL1807
4 WELLZONE 5V	• Control up to 5 zones	DDMX 70-175	7ACEL1808
5 WELLZONE 5V-6S	• Control up to 5 zones with 6 outputs	DDMX 70-175	7ACEL1903
6 WELLZONE 6V	• Control up to 6 zones	DDMX 70-175	7ACEL1809

		1 WELLZONE 3V	2 WELLZONE 4V	3 WELLZONE 4V-5S	4 WELLZONE 5V	5 WELLZONE 5V-6S	6 WELLZONE 6V
DESCRIPTION	QUANTITY	QUANTITY	QUANTITY	QUANTITY	QUANTITY	QUANTITY	QUANTITY
PACK WZ	Thermostat	3	4	4	5	5	6
	Programming timer	1	1	1	1	1	1
	Servomotor	3	4	5	5	6	6
	Control systems gateway	1	1	1	1	1	1
	Supply plenum	1	1	1	1	1	1
Return plenum	1	1	1	1	1	1	
ABS plenum grid (400x150 mm)	3	4	5	5	6	6	
Double deflection air supply grid in matt white aluminum (400x150 mm)	3	4	5	5	6	6	
Steel plenum grid (600x400 mm)	1	1	2	2	2	2	
White aluminium return filter holder grid (600x400 mm)	1	1	2	2	2	2	
Reducer (250/200 mm)	-	-	1	1	2	2	
10m polyester-insulated duct M1 (Ø200 mm)	4	5	7	7	8	8	
10m polyester-insulated duct M1 (Ø250 mm)	1	1	2	2	2	2	

* In a multisplit configuration, the DDMX is not Wellzone-compatible.

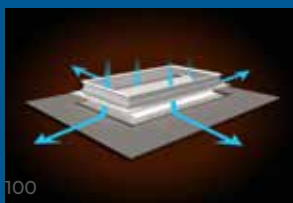

Customize design of air supply grids
according to interior of house.

SIMULATION FOR AN INSTALLATION IN 4 ZONES WITH 5 OUTPUTS / WELLZONE 4V-5S

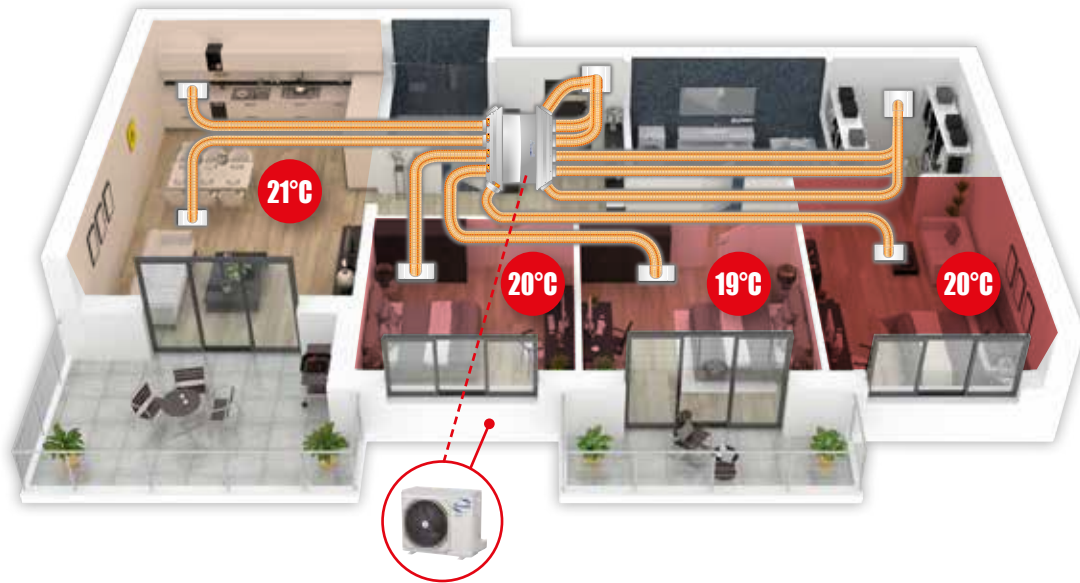

CONTENTS OF A COMPLETE WELLZONE KIT



REFERENCE	DUCT DIAMETER (Ø)	DIMENSIONS A x B x C
PLENUM 3S	250 > 200 > 160	1100 x 350 x 411
PLENUM 4S	200 > 160	1100 x 350 x 300
PLENUM 6S	250 & 200 > 160	1621 x 350 x 450

OPTION 2: YOUR CONTROL SYSTEMS GATEWAY SOLUTION

► Adjust according to your needs by selecting the Wellzone pack of your choice (see table below).

The most economic solution

COMPOSITION OF A REGULATION PACK

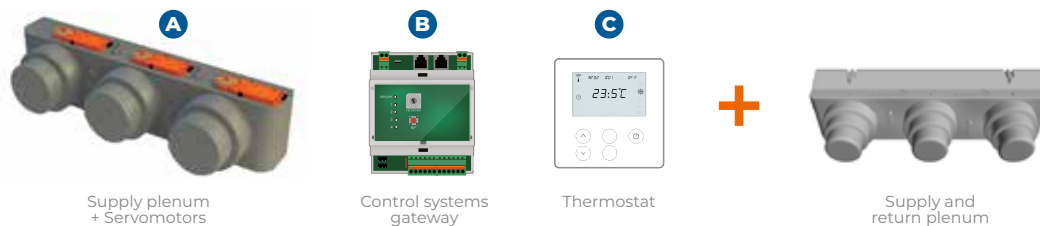

REFERENCE	DESCRIPTION	COMPATIBILITY	PART NUMBER
PACK WZ 3V	A x1 / B x1 / C x3	DDMX 35-50	7ACEL1810
PACK WZ 4V	A x1 / B x1 / C x4	DDMX 35-50	7ACEL1811
PACK WZ 4V-5S	A x1 / B x1 / C x4	DDMX 70-175	7ACEL1812
PACK WZ 5V	A x1 / B x1 / C x5	DDMX 70-175	7ACEL1813
PACK WZ 5V-6S	A x1 / B x1 / C x5	DDMX 70-175	7ACEL1904
PACK WZ 6V	A x1 / B x1 / C x6	DDMX 70-175	7ACEL1814

Don't forget the supply/return plenum in the composition of your Pack:

PLENUM 3S	Supply/return plenum	DDMX 35-50	7ACEL1822
PLENUM 4S	Supply/return plenum	DDMX 35-50	7ACEL1823
PLENUM 6S	Supply/return plenum	DDMX 70-175	7ACEL1824



VENTILATION

Range

MODEL	REFRIGERANT TYPE	SYSTEM	FUNCTION
<p>p.104</p>  <p>THERMODYNAMIC DUAL-FLOW CMV</p>	R32	Monoblock	Fan



Ventilation

HYBRID
HOUSE by Airwell

JDAA AIRFLOW

Thermodynamic dual-flow CMV



Remote control included

+ PRODUCT

- Remote control included
- Excellent COP
- No refrigerant handling
- Operates using 100% fresh air
- Compact unit

FEATURES



PROGRAMMABLE
TIMER



WEEKLY
TIMER



REMOTE CONTROL
LOCK



UNIT ON/OFF
OUTPUT

+ "SUSTAINABLE DEVELOPMENT"

- > High-performance product with COP > 7.

+ "USER"

- > Allows you to renew the air in the home by heating or cooling fresh air, thanks to a thermodynamic system.
- > Operates using 100% filtered fresh air.

+ "INSTALLER"

- > Simple to install, thanks to its Monoblock system.
- > This unit is suitable for any type of home.

+ "TECHNOLOGY"

- > Monoblock system.
- > Inverter technology.



Exhaust air from the house after energy recovery

Exhaust air from the house

100% fresh air from Outdoor

Purified and conditioning fresh air

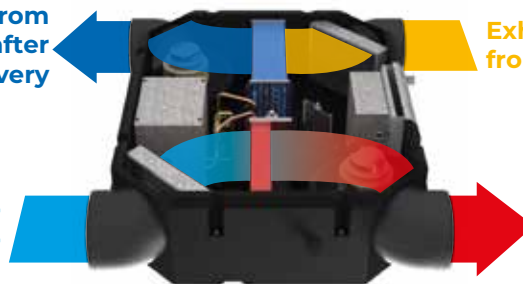

See technical draws page 158

TECHNICAL DATA

JDAA Airflow

MODEL		JDAA-022R-09M25				
Part number		7MB110001				
Phase		Single-phase				
Airflow	m ³ /h	125	150	210	270	320

HEATING

Outdoor air +7°C Air supply 20 °C	Heating capacity	kW	1.42	1.55	1.86	2.05	2.49
	Power input	kW	0.46	0.42	0.45	0.42	0.54
	COP		3.09	3.69	4.13	4.93	4.61
Outdoor air -5°C Air supply 20 °C	Heating capacity	kW	1.97	2.10	2.21	2.37	2.45
	Power input	kW	0.40	0.52	0.47	0.37	0.32
	COP		4.93	4.04	4.70	6.50	7.66

COOLING

Outdoor air 35°C Air supply 27°C	Cooling capacity	kW	1.57	1.64	1.73	1.92	2.07
	Power input	kW	0.36	0.52	0.53	0.55	0.81
	EER		4.34	3.15	3.26	3.50	2.56
Outdoor air 30°C Air supply 27°C	Cooling capacity	kW	0.92	1.38	1.47	1.72	2.07
	Power input	kW	0.36	0.52	0.48	0.54	0.81
	EER		2.56	2.65	3.06	3.21	2.77

PERFORMANCE

Static pressure	Rated	Pa	50	50	50	50	50
	Max.	Pa	120	120	120	120	120
Sound power level		dB(A)	47	48	50	54	58
Sound pressure level (l)		dB(A)	34	35	37	41	45

OPERATING LIMITS

Outdoor air temperature	Cooling	°C	16/45				
	Heating	°C	-15/28				

POWER SUPPLY

Phase/Voltage/Frequency		1P/230V/50Hz				
Power cable section	mm ²	3G1.5				
Fuse rating am	A	10				

INSTALLATION AND OTHERS

Refrigerant/GWP		R32/675
Charge	kg	0.30
Outline dimensions (WxHxD)	mm	1107x290x900
Package dimensions (WxHxD)	mm	1200x320x100
Net weight/Gross weight	kg	44/73

(l) The sound levels refer to the unit at full load, under rated test conditions.

Ventilation



CASSETTE

Range



MODEL	REFRI-GERANT TYPE	7	9	12	18	24	36	48	kBTU/h kW
		2	2.5	3.5	5	7	10	14	
<p>p.108</p>  <p>CDMX</p> <p>CASSETTE</p> <p>360° cassette</p>	R32	60x60	60x60	60x60	60x60	90x90	90x90	90x90	



DC Inverter
Reversible

CDMX

360° cassette

RC18
included



CDMX 022N-025N-035N-050N



CDMX 070N-100N-140N

+ PRODUCT

- RC18 remote control included (see page 130)
- Compact design
- 360° airflow
- Compatible with YDZC and ZDAA multisplits

FEATURES

TECHNOLOGY

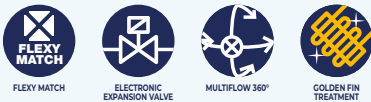

AIR QUALITY/CLEAN



USER FUNCTIONS



INSTALLER FUNCTIONS

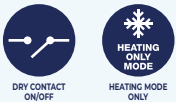

CERTIFICATION

- AIRWELL participates in the ECP programme for ACI. Check ongoing validity of certificate: www.eurovent-certification.com



+ “SUSTAINABLE DEVELOPMENT”

- > Energy label A++ in cooling mode and A+ in heating mode, guaranteeing energy savings.

+ “USER”

- > Design with a front panel that fits perfectly into false ceiling.
- > 360° air distribution in the room for a uniform temperature.

+ “INSTALLER”

- > Compact size ideal for low ceiling installations.
- > Parameter display on the indoor unit for quick reading.
- > Unit with pre-drilled holes for fresh air supply or blowing into a small room.
- > Maximum piping length up to 75m adapted to complex and remote installation.

+ “TECHNOLOGY”

- > On/Off contact included associated with a “room card” or other solution (not supplied) for better control and for energy savings.
- > Alarm contact (synthesis fault) included.
- > Room sensor built into the remote control for better comfort (“I Feel” mode by pressing the TURBO button on the remote control for 7 s).
- > Condensate pump included for automatic discharge.
- > Electronic expansion valve for better operating precision.
- > Golden Fin treatment on the heat exchangers (external and internal) for protection against corrosion and durability over time.
- > Wide operating range of -15° to 50°C in cooling mode and -15° to 24°C in heating mode.



OPTIONS

ACCESSORY	PART NUMBER	PICTURE	FUNCTION
Wired remote control RCW11 (see page 134)	7ACEL1774		• Weekly timer, mode, fan speed, On/Off timer, “I Feel” function, temperature.
Wired remote control RCW26 (see page 136)	7ACEL1876		• Controls until 16 indoor units.
LCAC Wi-Fi accessory	7ACEL1883		• Accessory for remote control via Wi-Fi. (compatible with CDMX-022N,025N,035N and 050N).
	7ACEL1900		• Accessory for remote control via Wi-Fi. (compatible with CDMX-070N-100N-140N).

See technical draws page 159

TECHNICAL DATA

MULTISPLIT CONFIGURATION ONLY

CDMX

INDOOR UNIT	MULTISPLIT CONFIGURATION ONLY									
	NEW	CDMX-022N-09M25	CDMX-025N-09M25	CDMX-035N-09M25	CDMX-050N-09M25	CDMX-070N-09M25	CDMX-100N-09M25	CDMX-100N-09M25	CDMX-140N-09M25*	
Part number	7SP042289	7SP042290	7SP042291	7SP042292	7SP042293	7SP042294	7SP042294	7SP042294	7SP042295	
Phase	Single-phase	Single-phase	Single-phase	Single-phase	Single-phase	Single-phase	Single-phase	Three-phase	Three-phase	
COOLING										
Rated power (min./max.)	kW	2.05 (0.63-2.61)	2.60 (0.8-3.3)	3.52 (0.85-4.11)	5.28 (2.90-5.59)	7.03 (3.30-7.91)	10.55 (2.70-11.43)	10.55 (2.70-11.43)	14.07 (3.52-15.83)	
Pdesignc	kW			3.50	5.30	7.00	10.50	10.50	14.00	
Rated power input	kW			1.01	1.63	2.32	3.95	4.00	4.65	
SEER/Energy label				6.6/A++	6.3/A++	6.2/A++	6.7/A++	6.3/A++	6.1/A++	
Operating limits	°C	-15°-50°C Dry bulb								
HEATING										
Rated power (min./max.)	kW	2.35 (0.69-3.0)	2.90 (0.85-3.7)	3.81 (0.47-4.31)	5.57 (2.37-6.10)	7.62 (2.81-8.94)	11.14 (2.78-12.30)	11.14 (2.78-12.66)	16.12 (4.10-17.29)	
Pdesignh (average climate)	kW			2.70	4.20	6.00	8.50	8.00	11.00	
Pdesignh (warmer climate)	kW			3.30	5.40	6.30	10.10	10.10	12.00	
Rated power input	kW			1.02	1.54	1.90	3.00	3.00	4.58	
SCOP/Energy label (average climate)				4.1/A+	4.0/A+	4.0/A+	4.0/A+	3.9/A	4.0/A+	
SCOP/Energy label (warmer climate)				5.1/A+++	4.8/A++	5.1/A+++	5.1/A+++	5.1/A+++	5.0/A++	
Operating limits	°C	-15°-24°C Dry bulb								
Power at -7°C	kW			2.95	4.10	5.97	9.13	8.91	12.50	
Power at -10°C	kW			2.82	3.91	5.70	8.71	8.50	11.93	
Power at -15°C	kW			2.64	3.67	5.34	8.16	7.96	11.17	
INDOOR UNIT										
Sound pressure level at 1 m (LS/MS/HS)	dB(A)	29/33/38	31/34/39	34/37/42	39/44/45	42/47/50	46/48/51	46/48/51	48/50/52	
Sound level	dB(A)	53	54	57	59	59	64	64	66	
Airflow (LS/MS/HS)	m³/h	400/460/500	400/460/500	420/510/590	479/584/680	992/1118/1247	1300/1530/1700	1300/1530/1700	1600/1750/1900	
Dehumidification	l/h	0.7	1.20	1.50	2.00	3.00	3.80	3.80	5.50	
Outline dimensions (WxHxD)	mm	570x260x570	570x260x570	570x260x570	570x260x570	830x205x830	830x245x830	830x245x830	830x287x830	
Package dimensions (WxHxD)	mm	662x317x662	662x317x662	662x317x662	662x317x662	910x250x910	910x290x910	910x290x910	910x330x910	
Net weight/Gross weight	kg	14.5/17.3	14.5/18.8	16.3/20.4	16/22.1	21.6/25.4	27.2/31.2	27.2/31.2	29.3/33.5	
PANEL										
Dimensions de la panel (WxHxD)	mm	647x50x647	647x50x647	647x50x647	647x50x647	950x55x950	950x55x950	950x55x950	950x55x950	
Package dimensions (WxHxD)	mm	715x123x715	715x123x715	715x123x715	715x123x715	1035x90x1035	1035x90x1035	1035x90x1035	1035x90x1035	
Net weight/Gross weight	kg	2.5/4.5	2.5/4.5	2.5/4.5	2.5/4.5	6/9	6/9	6/9	6/9	
Panel part number		7ACVF0566	7ACVF0566	7ACVF0566	7ACVF0566	7ACVF0600	7ACVF0600	7ACVF0600	7ACVF0600	

OUTDOOR UNIT		-	-	YDAX-035H-09M25	YDAX-050H-09M25	YDAX-070H-09M25	YDAX-100H-09M25	YDAX-100H-09T35	YDAX-140H-09T35	
Part number		-	-	7SP063170	7SP063171	7SP063172	7SP063173	7SP063174	7SP063175	
Sound pressure level at 1 m	dB(A)			51	54	58	59	59	63	
Sound level	dB(A)			62	65	69	70	70	74	
Airflow	m³/h			2200	2100	3500	4000	4000	7500	
Compressor type				Rotary	Rotary	Rotary	Rotary	Rotary	Rotary	
Outline dimensions (WxHxD)	mm			765x555x303	805x554x330	890x673x342	946x810x410	946x810x410	952x1333x415	
Package dimensions (WxHxD)	mm			887x610x337	915x615x370	995x740x398	1090x885x500	1090x885x500	1095x1480x495	
Net weight/Gross weight	kg			26.6/29	32.5/35.3	43.9/46.7	66.9/72.1	75.5/85.6	103.7/118.3	
POWER SUPPLY										
Phase/Voltage/Frequency		1P/220-240V/50Hz	1P/220-240V/50Hz	1P/220-240V/50Hz	1P/220-240V/50Hz	1P/220-240V/50Hz	1P/220-240V/50Hz	3P/380-415V/50Hz	3P/380-415V/50Hz	
Power supply side				Outdoor	Outdoor	Outdoor	Outdoor	Outdoor	Outdoor	
Power cable section	mm²			3G1.5	3G1.5	3G2.5	3G4.0	5G2.5	5G2.5	
Fuse rating am	A			16	16	20	25	16	16	
Electrical connections in/out	mm²	4G1.5	4G1.5	4G1.5	4G1.5	4G1.5	4G1.5	4G1.5	4G1.5	
PIPE LINE										
Suction pipe diameter	inches	3/8"	3/8"	3/8"	1/2"	5/8"	5/8"	5/8"	5/8"	
Liquid pipe diameter	inches	1/4"	1/4"	1/4"	1/4"	3/8"	3/8"	3/8"	3/8"	
Max. length	m			25	30	50	75	75	75	
Max. height	m			10	20	25	30	30	30	
Refrigerant/GWP				R32/675	R32/675	R32/675	R32/675	R32/675	R32/675	
Charge (5 m)	kg			0.72	1.15	1.50	2.40	2.40	2.90	
Additional charge	g/m			12	12	24	24	24	24	

MATCHING

INDOOR UNIT	COMPATIBLE WITH OUTDOOR UNIT			
	MONOSPLIT		MULTISPLIT	
CASSETTE				
 CDMX 022N & 025N		 YDAX	 ZDAA	 YDZC
 CDMX 035N-050N-070N		 YDAX	 ZDAA	 YDZC

MATCHING

INDOOR UNIT	COMPATIBLE WITH OUTDOOR UNIT	
	MONOSPLIT	
CASSETTE		
 CDMX 100N	 YDAX	 YDAX
 CDMX 140N	 YDAX	 YDAX

Cassette



Airwell

MONOBLOCK

Range

MODEL	REFRIGERANT TYPE	10 2.9	12 3.5	kBTU/h kW
<p>p.112</p>  <p>XDAW</p> <p>R32</p> <p>•</p> <p>MONOBLOCK CONSOLE <i>Solution without outdoor unit</i></p>				
<p>p.113</p>  <p>WFAE</p> <p>R32</p> <p>• •</p> <p>WINDOW <i>Prefabricated buildings solution</i></p>				
<p>p.114</p>  <p>MFH</p> <p>R290</p> <p>• •</p> <p>PORTABLE <i>Cooling only</i></p>				



DC Inverter
Reversible



XDAW Monoblock console - Built-in Wi-Fi



► **New design!**



XDAW RC
included

COMPATIBLE



No outdoor
unit



+ PRODUCT

- XDAW RC remote control included
- Monoblock solution
- Reversible product (cooling/heating)
- No outdoor unit
- No fluid handling

+ “SUSTAINABLE DEVELOPMENT”

- > Environment friendly R32 refrigerant, low energy consumption.

+ “USER”

- > Ideal for modular constructions.

+ “INSTALLER”

- > Ease of installation
- > Plug & Play.

+ “TECHNOLOGY”

- > Inverter technology.
- > Monoblock (no outdoor unit).

TECHNICAL DATA

INDOOR UNIT		XDAW-023R-09M25
Part number		7MB070003
Phase		Single-phase
COOLING		
Rated power	kW	2.35 (1.5-3.0)
Rated power input	kW	0.90
EER/Energy label		2.61/A
Operating limits	°C	-10°~43°C Dry bulb
HEATING		
Rated power	kW	2.36 (1.0-2.8)
Rated power input	kW	0.76
COP/Energy label		3.11/A
Operating limits	°C	-15°~24°C Dry bulb
INDOOR UNIT		
Sound pressure level at 1 m (LS/MS/HS)	dB(A)	29/46/48
Sound level	dB(A)	56
Airflow	m ³ /h	480
Dehumidification	l/h	0.04
Outline dimensions (WxHxD)	mm	965x615x200
Package dimensions (WxHxD)	mm	1030x765x280
Net weight/Gross weight	kg	39/41
POWER SUPPLY		
Phase/Voltage/Frequency		1P/220-240V/50Hz
Power cable section	mm ²	3x2.5
Fuse rating am	A	16
PIPE LINE		
Refrigerant/GWP		R32/675
Charge	kg	0.39

See technical draws page 162

WFAE Window



WFAE RC
included

⊕ “SUSTAINABLE DEVELOPMENT”

> Environment friendly R32 refrigerant, low energy consumption.

⊕ “USER”

> Ideal for modular constructions.

⊕ “INSTALLER”

> Ease of installation

⊕ “TECHNOLOGY”

> Inverter technology.

TECHNICAL DATA

INDOOR UNIT		WFAE-025C-09M25	WFAE-035C-09M25
Part number		7MB050001	7MB050002
Phase		Single-phase	Single-phase
COOLING			
Rated power	kW	2.75	3.70
Pdesignc	kW	2.75	3.70
Rated power input	kW	0.81	1.09
SEER/Energy label		5.10/A	5.10/A
Operating limits	°C	18°/43° Dry bulb	
INDOOR UNIT			
Sound pressure level at 1 m (LS/MS/HS)	dB(A)	45/47/49	45/47/49
Airflow (LS/MS/HS)	m³/h	310/350/380	400/450/490
Dehumidification	l/h	1.00	1.20
Compressor type		Rotary	Rotary
Outline dimensions (WxHxD)	mm	560x375x710	660x428x700
Package dimensions (WxHxD)	mm	623x425x806	739x515x793
Net weight/Gross weight	kg	34/36.7	46/50
POWER SUPPLY			
Phase/Voltage/Frequency		1P/230V/50Hz	1P/230V/50Hz
Power supply side		Indoor	Indoor
Power cable section	mm²	3x1.0	3x1.5
Fuse rating am (D curve)	A	10	10
PIPE LINE			
Refrigerant/GWP		R32/675	R32/675
Charge	kg	0.51	0.63

See technical draws page 162

DC Inverter
Cooling only



+ PRODUCT

- WFAE RC remote control included
- Monoblock solution
- No fluid handling

FEATURES

TECHNOLOGY



NIGHT MODE



RESTART
AUTO RESTART
(MEMORY)

INSTALLER FUNCTIONS



AUTO-DIAGNOSTIC



Fixed speed
Cooling only



MFH Portable



RC08C
included

+ PRODUCT

- RC08C remote control included (see page 126)
- Monoblock solution
- No fluid handling

FEATURES

AIR QUALITY



ANTIBACTERIAL
FILTER



AUTO
CLEAN/DRY

USER FUNCTIONS



I FEEL



NIGHT MODE



24 H
PROGRAMMABLE
TIMER



RESTART
(MEMORY)



REMOTE CONTROL
LOCK

INSTALLER FUNCTIONS



AUTO-DIAGNOSTIC

+ "SUSTAINABLE DEVELOPMENT"

- > Environment friendly R290 refrigerant.

+ "USER"

- > Easy to move thanks to its castors and handles.
- > Easy reading thanks to its digital display on the control panel.
- > Remotely controllable with the RC unit.
- > High comfort thanks to its cooling capacity.

+ "TECHNOLOGY"

- > Caulking kit included.
- > Condensate evacuation by evaporation.

TECHNICAL DATA

INDOOR UNIT		AW-MFH010-C41	AW-MFH012-C41
Part number		7MB021060	7MB021061
Phase		Single-phase	Single-phase
COOLING			
Rated power	kW	2.93	3.52
Rated power input	kW	0.94	1.35
Courant	A	4.50	5.90
EER/Energy label		3.10/A+	2.60/A
Operating limits	°C	17°/35° Dry bulb	
INDOOR UNIT			
Type		Monoblock	Monoblock
Sound pressure level at 1 m (LS/MS/HS)	dB(A)	50/51/52	50/51/52
Sound level	dB(A)	62	63
Airflow (LS/MS/HS)	m³/h	355/370/420	355/370/420
Diameter flexible emission duct	mm	150	
Length range of heat emission duct	m	0.50 - 1.50	
Dehumidification	l/h	1.60	1.80
Unit dimensions (WxHxD)	mm	467x765x397	467x765x397
Package dimensions (WxHxD)	mm	515x890x440	515x890x440
Net weight/Gross weight	kg	31.8/35.7	33/36.5
POWER SUPPLY			
Phase/Voltage/Frequency		1P/230V/50Hz	1P/230V/50Hz
PIPE LINE			
Refrigerant/GWP		R290/20	R290/20
Charge	kg	0.21	0.22

*Min. pack 8 pcs.



See technical draws page 163

A series of horizontal dotted lines for writing, arranged in 20 rows.



WATER-COOLED

Range

MODEL	REFRI-GERANT TYPE	5	9	12	17	21	31	51	71	101	kBTU/h kW
		2	2.5	3.5	4.1	4.5	8	10	17	25	
<p>p.118</p>  <p>XDOW</p> <p>WATER-COOLED CONSOLE</p> <p><i>Reversible monoblock</i></p>	R410A		•	•							
<p>p.120</p>  <p>DFMO</p> <p>WATER-LOOP HEAT PUMP</p> <p><i>Ideal for stores</i></p>	R410A	•	•		•	•	•	•	•	•	



DC Inverter
Reversible



XDOW

Water-cooled console



Optimal comfort:
reversible solution

+ PRODUCT

- Solution without outdoor unit
- Monoblock
- Simple design
- Quiet (25 dB)

+ “SUSTAINABLE DEVELOPMENT”

- > Reduced water consumption thanks to the built-in modulating valve.

+ “USER”

- > Compact.
- > Quiet.
- > Ideal solution for historic buildings (monoblock).

+ “INSTALLER”

- > Plug & Play: hydraulic connection only.

+ “TECHNOLOGY”

- > Compatible with water-loop and public water supply.

TECHNICAL DATA

INDOOR UNIT		XDOW-025R-01M25	XDOW-035R-01M25
Part number		7MB070001	7MB070002
Phase		Single-phase	Single-phase
COOLING			
Rated power (1)	kW	2.50	3.50
Pdesignc	kW	2.30	3.20
Rated power input	kW	0.38	0.76
EER/Energy label		4.08/A++	4.05/A++
Operating limits	°C	18°/35°	
Maximum water temperature	°C	40°C	
HEATING			
Rated power (2)	kW	2.70	3.80
Pdesignh	kW	2.50	3.40
Rated power input	kW	0.71	1.09
COP/Energy label		4.33/A++	4.31/A++
Operating limits	°C	5°/27°	
Minimum water temperature	°C	7°C	
INDOOR UNIT			
Sound pressure level to 2 m	dB(A)	25	27
Sound level (LS/MS/HS)	dB(A)	41/46/52	43/48/54
Airflow (LS/MS/HS)	m ³ /h	250/310/385	310/410/435
Recycled water flow	l/h	430	600
Wastewater flow (15°C)	l/h	107	150
Dehumidification	l/h	1.10	1.30
Compressor type		Rotary DCI	Rotary DCI
Outline dimensions (WxHxD)	mm	1030x555x165	1030x555x165
Package dimensions (WxHxD)	mm	1100x660x260	1100x660x260
Net weight/Gross weight	kg	48.5/50.5	49.5/51.5
POWER SUPPLY			
Phase/Voltage/Frequency		1P/220-240V/50Hz	1P/220-240V/50Hz
Power supply side		Indoor	Indoor
Power cable section	mm ²	3x1.5	3x1.5
Fuse rating am (D curve)	A	6	6
PIPE LINE			
Refrigerant/GWP		R410A/2088	R410A/2088
Charge	kg	0.65	0.65

(1) Conditions: Dry bulb 27°C - Wet bulb 19°C - Water at 30°C ΔT 5K.

(2) Conditions: Dry bulb 20°C - Wet bulb 15°C - Water at 15°C ΔT 5K.

See technical draws page 164

Table with 10 columns and 30 rows, all cells are empty.



Fixed speed
Reversible

DFMO 22 TO 41

Water-loop heat pump



Remote control
included

+ PRODUCT

- Remote control included (see page 140)
- Solution without outdoor unit
- Monoblock
- Compact design
- Wide power range
- Thermostat included (ref. 7ACEL1880)

FEATURES

TECHNOLOGY



(1) Ambient air at 27°C DB/19°C WB. Exchanger water inlet/outlet temperature 30°C/35°C.

(2) Ambient air at 20°C DB. Exchanger water inlet temperature 20°C. The exchanger water outlet temperature is obtained as a function of the cooling water flow rate.

(3) Ambient air at 20°C DB. Exchanger water inlet temperature 15°C. The exchanger water outlet temperature is obtained as a function of the cooling water flow rate.

(4) Water flow rate calculated based on the cooling performance.

(5) Data calculated according to EN14825: 2016.

+ “SUSTAINABLE DEVELOPMENT”

> High efficiency.

+ “USER”

> Fire classification: M0 (ERP compatible).

+ “INSTALLER”

> Alarm output for fault reporting.

+ “TECHNOLOGY”

> Built-in temperature sensors for optimized consumption.

TECHNICAL DATA

INDOOR UNIT		DFMO-022N-01M25	DFMO-031N-01M25	DFMO-041N-01M25
Part number		7MB030001	7MB030002	7MB030003
Phase		Single-phase	Single-phase	Single-phase
COOLING				
Rated power ⁽¹⁾	kW	2.26	3.16	4.16
Rated sensitive power	kW	1.91	2.75	3.50
Total power input	kW	0.54	0.74	0.92
EER		4.22	4.28	4.51
HEATING - AIR AT 20 °C - WATER AT 20 °C				
Rated power ⁽²⁾	kW	2.76	3.85	4.92
Total power input	kW	0.55	0.77	1.06
COP		4.99	4.97	4.66
HEATING - AIR AT 20 °C - WATER AT 15 °C				
Rated power ⁽³⁾	kW	2.46	3.33	4.42
Total power input	kW	0.55	0.73	1.02
COP		4.42	4.47	4.30
INDOOR UNIT				
Sound pressure level at 1 m	dB(A)	33	34	35
Number of compressors	nb	1	1	1
Compressor type			Rotary	
Airflow	m ³ /h	533	612	800
Fan type			Centrifuge	
Number of fans	nb	1	1	1
External static pressure	Pa	40 (0-80)	40 (0-80)	40 (0-80)
Water inlet flow ⁽⁴⁾	l/s	0.13	0.18	0.24
Outline dimensions (WxHxD)	mm	1034x361x513	1034x361x513	1034x386x513
Net weight/Gross weight	kg	71/81	74/84	82/92
POWER SUPPLY				
Phase/Voltage/Frequency		1P/230V/50Hz	1P/230V/50Hz	1P/230V/50Hz
ERP DATA ⁽⁵⁾				
SEER		3.75	3.90	4.18
SCOP		3.41	3.63	4.05
PIPE LINE				
Refrigerant/GWP		R410A/2088	R410A/2088	R410A/2088
Charge	kg	0.47	0.64	1.30

OPTIONS

ACCESSORY

PART NUMBER

Modbus DFMO 22 to 41

7ACEL1881

Modulating valve DFMO 22 to 41

7ACFH0850

See technical draws page 164

DFMO 45 TO 250

Water-loop heat pump



Remote control included

Fixed speed
Reversible



⊕ “SUSTAINABLE DEVELOPMENT”

> High efficiency.

⊕ “USER”

> Fire classification: M0 (ERP compatible).

⊕ “INSTALLER”

> Alarm output for fault reporting.

⊕ “TECHNOLOGY”

> Built-in temperature sensors for optimized consumption.

+ PRODUCT

- Remote control included (see page 140)
- Solution without outdoor unit
- Monoblock
- Compact design
- Wide power range
- Thermostat included (ref. 7ACEL1880)

TECHNICAL DATA

INDOOR UNIT		DFMO-045N-01M25	DFMO-080N-01M25	DFMO-100N-01M25	DFMO-170N-01T35	DFMO-250N-01M25
Part number		7MB030004	7MB030005	7MB030006	7MB030007	7MB030008
Phase		Single-phase	Single-phase	Single-phase	Three-phase	Three-phase
COOLING						
Rated power ⁽¹⁾	kW	4.56	8.08	10.60	16.90	25.00
Rated sensitive power	kW	3.74	6.44	8.84	13.90	20.00
Total power input	kW	1.30	2.07	3.04	4.15	5.85
EER		3.52	3.90	3.53	4.07	4.27
HEATING						
Rated power ⁽²⁾	kW	7.55	10.30	14.40	23.10	33.20
Total power input	kW	1.75	2.39	3.35	5.23	7.21
COP		4.30	4.31	4.30	4.41	4.60
INDOOR UNIT						
Sound pressure level at 1m ⁽³⁾	dB(A)	42	42	44	45	45
Number of compressors	nb	1	1	1	1	1
Compressor type		Rotary	Rotary	Rotary	Scroll	Scroll
Airflow	m ³ /h	1000	1500	2800	3800	4900
Fan type		Centrifuge				
Number of fans	nb	1	1	1	1	1
External static pressure ⁽⁴⁾	Pa	250	270	290	310	220
Water inlet flow	l/s	0.27	0.47	0.64	1.00	1.47
Outline dimensions (WxHxD)	mm	962x490x692	962x490x692	1167x590x802	1167x590x802	1467x705x927
Net weight/Gross weight	kg	98/102	103/107	138/143	151/156	200/225
POWER SUPPLY						
Phase/Voltage/Frequency		1P/230V/50Hz	1P/230V/50Hz	1P/230V/50Hz	3P/400V/50Hz/N	3P/400V/50Hz/N
ERP DATA ⁽⁵⁾						
SEER		3.28	3.93	3.57	4.23	4.47
SCOP		3.81	3.82	3.81	3.91	4.08
PIPE LINE						
Refrigerant/GWP		R410A/2088				
Charge	kg	0.70	0.95	1.10	1.30	3.20

OPTIONS

ACCESSORY

PART NUMBER

Modulating valve DFMO 45-170	7ACFH0851
Modulating valve DFMO 250	7ACFH0852

See technical draws page 166

(1) Ambient air at 27°C DB/19°C WB. Exchanger water inlet/outlet temperature 30°C/35°C.

(2) Ambient air at 20°C DB. Exchanger water inlet temperature 20°C. The exchanger water outlet temperature is obtained as a function of the cooling water flow rate.

(3) Ambient air at 20°C DB. Exchanger water inlet temperature 15°C. The exchanger water outlet temperature is obtained as a function of the cooling water flow rate.

(4) Water flow rate calculated based on the cooling performance.



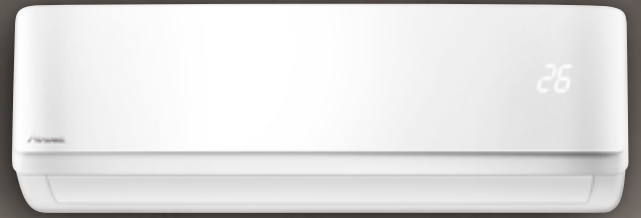





(5) Data calculated according to EN14825: 2016.



CONTROL SYSTEMS

Range

	MODEL	WIRELESS CONTROLLER	WIRED REMOTE CONTROL
p.124	COMPATIBILITY TABLES		
p.125	FUNCTION TABLES		
p.126	 RC08C	•	
p.128	 RC08A	•	
p.130	 RC18	•	
p.132	 RC19	•	
p.134	 RCW11		•
p.136	 RCW26		•
p.138	 RCW27		•
p.140	 Remote control for DFMO		•

MODEL	WIRELESS CONTROLLER				WIRED REMOTE CONTROL						
REFERENCE	RC08C	RC08A	RC18	RC19	RCW8	RCW11	RCW22	RCW25	RCW26	RCW27	BMS GATEWAY
Part number	7ACEL1740	7ACEL1791	7ACEL1898	7ACEL1899	7ACEL1706	7ACEL1774	7ACEL1778	7ACEL1832	7ACEL1876	7ACEL1874	7ACEL1708
Picture											
HIGH WALL											
HDHC Artica			●								
HDMB Harmonia				●			●				
HDLE Aura		●								●	
HDLA Aura				●	●						
CONSOLE, FLOOR CEILING & FLOOR STANDING											
XDLF		●								●	
FDMX			●			●			●		●
FDLK								●			
SDMX				●							
DUCTED											
DDMX			●			●			●		●
CASSETTE											
CDMX			●			●			●		●
MONOBLOCK											
MFH	●										

FUNCTION TABLES

MODEL	WIRELESS CONTROLLER				WIRED REMOTE CONTROL			
REFERENCE	RC08C	RC08A	RC18	RC19	RCW11	RCW25	RCW26	RCW27
Part number	7ACEL1740	7ACEL1791	7ACEL1898	7ACEL1899	7ACEL1774	7ACEL1832	7ACEL1876	7ACEL1874
Picture								
USER FUNCTIONS								
On/Off timer	●	●	●	●	●	●	●	●
Weekly timer					●		●	●
Silent mode/low speed fan	●	●	●	●	●	●	●	
"I Feel" function	●	●	●	●	●		●	●
Clean-up function	●	●	●	●				
Night mode (economy mode)	●	●	●	●				●
Remote locking	●	●	●	●	●	●	●	●
Turbo mode	●	●	●	●			●	●
Low battery	●	●	●	●	●			
No frost mode	●	●	●	●				●
INSTALLER FUNCTIONS								
Technician test mode	●	●	●	●				
Group control							●	
Compensation temperature	●	●	●	●		●		
Heating mode only	●	●	●	●				
Priority mode definition (multisplit)	●	●						
Parameter display function (temperature, expansion valve opening, compressor...)	●	●	●	●				
Operating fault display					●	●	●	●

● Standard remote

● Optional remote

RC08C

Part number: 7ACEL1740



COMPATIBLE PRODUCTS

- MFH

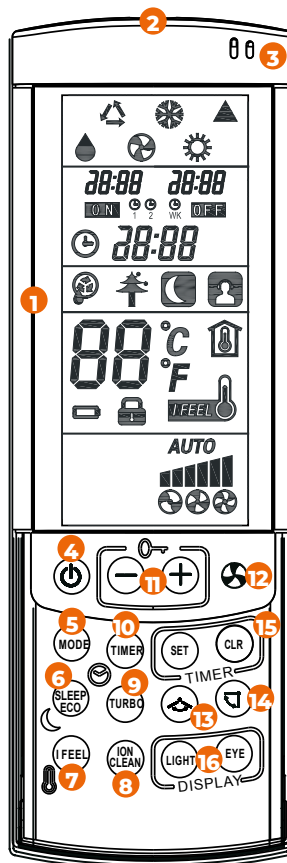

1 ► DISPLAY

Information is displayed when the remote control is on.	
Operating mode	• Automatic
	• Heating
	• Cooling
	• Ventilation only
	• Dehumidify (drying mode)
	• Send data to the air conditioner receiver
	• Clock (hours and minutes)
	• "Time On" function configured and activated
	• "Time Off" function configured and activated
	• Programming repeat function
	• Sleep operating mode
	• Quiet mode
	• Cleaning mode
	• Ionizer /E.S.F. mode
	• Selects or indicates the room temperature
	• Displayed when the temperature reached is the room setpoint
Description of low battery detection	• The low-battery indicator on the remote control will continue to blink when the batteries are low. This may reduce the transmission distance of the remote control, and blur the display. • Replace with new batteries immediately. • The low-battery indicator will disappear after the batteries have been replaced.
Fan speed indication	• Low speed
	• Medium speed
	• High speed
	• Fan auto speed

2 ▶ TRANSMITTER

- When you press the buttons of the remote control unit, the ▲ symbol appears on the display to transmit the setting changes to the air conditioner receiver.

3 ▶ SENSOR







- The air temperature sensor inside the remote control unit measures the room temperature.

4 ▶ ON/OFF BUTTON

- This button turns the air conditioner ON and OFF.

5 ▶ MODE SELECTOR BUTTON

Press this button to change the mode.

	• Automatic. When this mode is selected, the air conditioner calculates the difference between the thermostat setting and the room temperature and automatically switches to "cooling" or "heating" mode.
	• Heating. The air conditioner heats the ambient air.
	• Cooling. The air conditioner cools the room.
	• Ventilation only. The air conditioner circulates the air.
	• Dehumidify (dry mode). The air conditioner reduces the humidity of the air in the room.
	• Cool / Dry / Heat

6 ▶ SLEEP/ECO BUTTON

This button has 2 functions:

- **SLEEP function** (short press)
 - **ECONOMY function** (long press)
- For more details, refer to "SLEEP mode function" and "ECONOMY mode function".

7 ▶ "I FEEL" BUTTON FOR ROOM TEMPERATURE DETECTION AND DISPLAY

- Activates **temperature detection** in the vicinity of the remote control. This function is available in AUTO, COOL and HEAT mode.

8 ▶ ION/CLEAN BUTTON

This button has 2 functions:

- **The ION function** (ionizer): short press
 - **The CLEAN function:** long press
- For more details, refer to "Ionizer mode function (OPTIONAL)" and "CLEAN mode function".

9 ▶ TURBO BUTTON

- Activates the **TURBO function** to speed up heating or cooling.

10 ▶ TIMER BUTTON (PROGRAMMING)

- Activates/deactivates **PROGRAMMING**.
- For more details, refer to "SETTING THE TIMER".

11 ▶ TEMPERATURE SETTING BUTTONS

- - (cooler). Reduce the set temperature.
 - + (warmer). Increase the set temperature.
- Press the "-" and "+" buttons simultaneously to lock or unlock the keypad.

12 ▶ FAN SPEED SELECTOR BUTTON

Press this button to change the mode.

	• The fan speed is selected automatically.		• High speed
	• Medium speed		• Low speed

Press this button for at least 2 seconds to activate Silent mode.

13 ▶ HORIZONTAL AIR SWEEP BUTTON

- If the air conditioner has a horizontal sweep motor, press the button to activate **automatic horizontal air sweeping**.

14 ▶ VERTICAL SWING BUTTON

- Activates **automatic vertical air sweep swing**.
- For more details, refer to "ADJUSTING THE AIRFLOW DIRECTION".

15 ▶ SET/CLEAR BUTTONS

- **SET button.** Selects the following functions: setting the time/setting the programming ON/OFF.
For details, refer to "SETTING THE CURRENT TIME" and "SETTING THE TIMER".
- **CLEAR button.** Press the CLEAR button to cancel all programming operations.

16 ▶ LIGHT/EYE BUTTONS

- **LIGHT button.** Press this button to turn the indoor unit display ON/OFF. Turns beep ON/OFF.
- **EYE button (optional).** Detects human presence in the room and activates start or standby mode.

RC08A

Ref.: 7ACEL1791

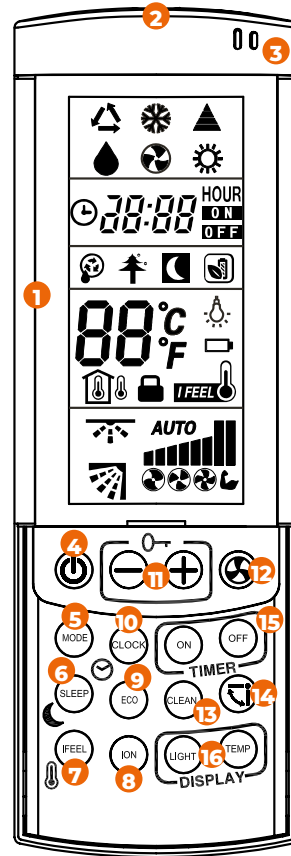

COMPATIBLE PRODUCTS

- HDLE Aura
- XDLF

1 ► DISPLAY

Information is displayed when the remote control is on.	
Operating mode	• Automatique
	• Heating
	• Cooling
	• Airflow only
	• Dehumidification (drying mode)
	• Send data to the air conditioner receiver
	• Clock (hours and minutes)
	• "Time On" function configured and activated
	• "Time Off" function configured and activated
	• Cleaning mode
	• Sleep operating mode
	• Ionizer /E.S.F. mode
	• Eco mode
	• Selects or indicates the room temperature
	• Displayed when the temperature reached is the room setpoint
	Description of low battery detection
• Low speed	
Fan speed indication	• Medium speed
	• High speed
	• Fan auto speed
	• Turbo function

2 ▶ TRANSMITTER

- When you press the buttons of the remote control unit, the ▲ symbol appears on the display to transmit the setting changes to the air conditioner receiver.

3 ▶ SENSOR







- The air temperature sensor inside the remote control unit measures the room temperature.

4 ▶ ON/OFF BUTTON

- This button turns the air conditioner ON and OFF.

5 ▶ MODE SELECTOR BUTTON

Press this button to change the mode.

	• Automatic. When this mode is selected, the air conditioner calculates the difference between the thermostat setting and the room temperature and automatically switches to "cooling" or "heating" mode.
	• Heating. The air conditioner heats the ambient air.
	• Cooling. The air conditioner cools the room.
	• Ventilation only. The air conditioner circulates the air.
	• Dehumidify (dry mode). The air conditioner reduces the humidity of the air in the room.
	• Cool / Dry / Heat

6 ▶ SLEEP/ECO BUTTON

This button has 2 functions:

- **SLEEP function** (short press)
 - **ECONOMY function** (long press)
- For more details, refer to "SLEEP mode function" and "ECONOMY mode function".

7 ▶ "I FEEL" BUTTON FOR ROOM TEMPERATURE DETECTION AND DISPLAY

- Activates **temperature detection** in the vicinity of the remote control. This function is available in AUTO, COOL and HEAT mode.

8 ▶ ION/CLEAN BUTTON

This button has 2 functions:

- **The ION function** (ionizer): short press
 - **The CLEAN function**: long press
- For more details, refer to "Ionizer mode function (OPTIONAL)" and "CLEAN mode function".

9 ▶ ECO BUTTON

- **Cooling.** Automatically adjust the temperature for energy savings. The temperature display will show "SE".
- **Heating.** Select heating level 8. The remote control screen displays the temperature "8 C".

10 ▶ CLOCK BUTTON





- The clock displays the **current time**.
- For more details refer to the section "How to set the current time".

11 ▶ TEMPERATURE SETTING BUTTONS

- - (**cooler**). Reduce the set temperature.
 - + (**warmer**). Increase the set temperature.
- Press the "-" and "+" buttons simultaneously to lock or unlock the keypad.

12 ▶ FAN SPEED SELECTOR BUTTON

Press this button to change the mode.

	• The fan speed is selected automatically.		• High speed
	• Medium speed		• Low speed
	• Turbo function		

13 ▶ CLEAN BUTTON

- This button deactivates the **cleaning function** in Cooling and Dehumidification modes.

14 ▶ SWING BUTTON

- Activates the **air supply louver swing** in various positions or automatic swing.
- For more details refer to the section "Setting the airflow direction".

15 ▶ TIMER BUTTONS (ON/OFF)

- Press the ON or OFF button to **activate the setting procedure**.
- For more details refer to the section "Setting the timer".

16 ▶ LIGHT/TEMP BUTTONS

- **LIGHT button.** Enables or disables the remote control display.
- **TEMP button.** Displays the configured temperature, room temperature or outdoor temperature.

SWITCHING TO HEATING MODE ONLY

- 
- Remove the batteries from the remote control.
 - Wait for the screen to turn off completely.
 - Insert the batteries.
 - Within 60 seconds of inserting the batteries: - The remote control must be in OFF mode.
 - Press "I FEEL" and "TEMP" at the same time for 5 s.
 - The heating mode icon will flash 3 times.
 - After this setting, the remote control is permanently locked in heating mode. No switching back.

RC18

Ref.: 7ACEL1898



COMPATIBLE PRODUCTS

- HDHC Artica
- FDMX
- DDMX (optional)
- CDMX

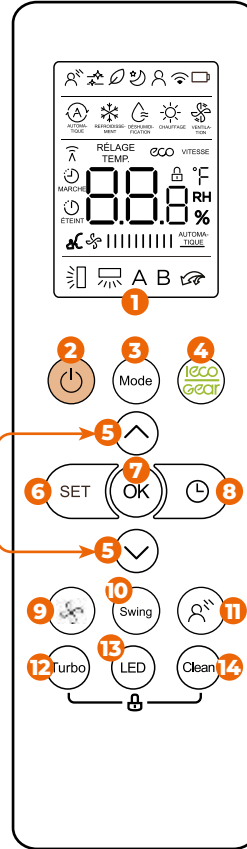

1 ► DISPLAY

Information is displayed when the remote control is on.		
Operating mode	• Breeze Away display	
	• Active clean feature display	
	• Fresh feature display	
	• Sleep mode display	
	• "I Feel" function display	
	• Wireless control feature display	
	• Low battery detection display (if flashing)	
	• AUTO mode	
	• COOLONG mode	
	• DRY mode	
	• HEATING mode	
	• FAN mode	
	• Transmission Indicator: lights up when remote sends signal to indoor unit	
	• TIMER ON display	
• TIMER OFF display		
Temperature/ Timer/Fan speed display	• Displays the default set temperature, or fan speed or timer setting when using On/Off timer functions. • Temperature range: 16-30°C • Timer setting range: 0-24 hours • Fan speed setting range: AU -100% • This display is blank when operating in FAN mode.	
	Fan speed display	• Silence 1%
		• Low 21%-40%
		• Medium 41%-60%
• High 61%-80%		
• High 81%-100%		
Louver swing display	• Auto This fan speed can not be adjusted in AUTO or DRY mode.	
	• Horizontal louver swing display	
	• Vertical louver auto swing display (optional function)	
	• Not available for this unit	
	• TURBO mode display	

2 ▶ ON/OFF BUTTON

- Turns the unit on or off.





3 ▶ MODE BUTTON

- Scrolls through operation modes as follows: AUTO → COOL → DRY → HEAT → FAN

4 ▶ ECO/GEAR BUTTON





- Press this button to enter the energy saving mode in the following sequence: ECO → GEAR (75%) → GEAR (50%) → Previous setting mode → ECO

5 ▶ TEMP BUTTON

-  Increases temperature in 1°C (1°F) increments. Max. temperature is 30°C (86°F).
-  Decreases temperature in 1°C (1°F) increments. Min. temperature is 16°C (60°F).
- **NOTE:** Pressing buttons  and  at the same time for 3 seconds will alternate the temperature display between the °C & °F.

6 ▶ SET BUTTON

Scrolls through the operating functions as follows:

- Fresh  → Sleep  → "I Feel"  → AP mode  → Fresh .
- The selected symbol will flash on the display area. Press the OK button to confirm.



7 ▶ OK BUTTON

- Used to confirm the selected functions

8 ▶ TIMER BUTTON

- Set the timer to turn the unit on or off.

9 ▶ FAN SPEED BUTTON

- Selects fan speeds in the following order: AU → 20% → 40% → 60% → 80% → 100%.
- Press the  or  button to increase/decrease the fan speed in 1% increments.

10 ▶ SWING BUTTON

- Starts and stops the louver movement.

11 ▶ BREEZE AWAY BUTTON

- This feature avoids direct air being blown directly at you or any other occupants.
- **NOTE:** This feature is available in Cooling, Fan and Dry modes only

12 ▶ TURBO BUTTON

- Enables unit to reach preset temperature in shortest possible time.
- To activate "I Feel" mode, press the "TURBO" button for 7 s.

13 ▶ LED BUTTON

- Turns the air conditioner's buzzer on and off (depending model), which create a comfortable and quiet environment.

14 ▶ CLEAN BUTTON

- This function is used to clean the air conditioner's evaporator, to prevent frosting.

RC19

Ref.: 7ACEL1899

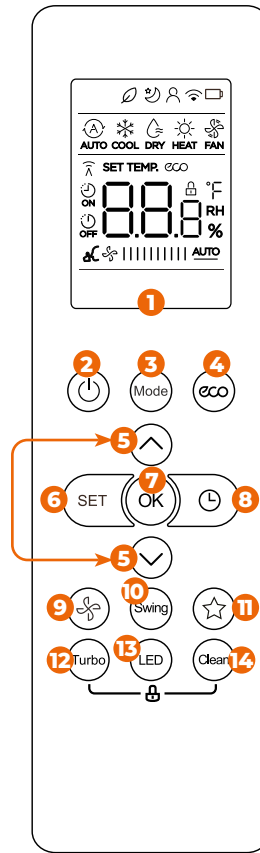

COMPATIBLE PRODUCTS

- HDMB
- HDLA
- SDMX

1 ► DISPLAY

Information is displayed when the remote control is on.		
Operating mode		• Fresh function display • (No displays when Fresh function is activated)
		• Sleep mode display
		• "I Feel" function display
		• Wireless control function display
		• Low battery detection display (if flashing)
		• AUTO mode
		• COOLONG mode
		• DRY mode
		• HEATING mode
		• FAN mode
		• Transmission Indicator: lights up when remote sends signal to indoor unit
		• TIMER ON display
		• TIMER OFF display
		• Silence function display
Temperature/ Timer/Fan speed display		• Displays the default set temperature, or fan speed or timer setting when using On/Off timer functions. • Temperature range: 17-30 °C/62-86 °F (20-28 °C) (model dependent) • Timer setting range: 0-24 hours • This display is blank when operating in FAN mode.
		• Silence 1% • Low 21%-40% • Medium 41%-60% • High 61%-80% • Auto 81%-100% This fan speed can not be adjusted in AUTO or DRY mode.
		• LOCK display: displays when LOCK function is activated.

2 ▶ ON/OFF BUTTON

- Turns the unit on or off.





3 ▶ MODE BUTTON

- Scrolls through operation modes as follows: AUTO → COOL → DRY → HEAT → FAN
- **NOTE:** HEAT mode is not supported by the cooling only appliance.

4 ▶ ECO BUTTON





- Press this button to enter the energy saving mode.

5 ▶ TEMP BUTTON

-  Increases temperature in 1°C (1°F) increments. Max. temperature is 30°C (86°F).
-  Decreases temperature in 1°C (1°F) increments. Min. temperature is 17°C (62°F).
- **NOTE:** Press buttons  and  at the same time for 3 seconds will alternate the temperature display between the °C & °F.

6 ▶ SET BUTTON

Scrolls through the operating functions as follows:

- Fresh  → Sleep  → "I Feel"  → AP mode  → Fresh .
- The selected symbol will flash on the display area, press the OK button to confirm.

7 ▶ OK BUTTON

- Used to confirm the selected functions

8 ▶ TIMER BUTTON

- Set the timer to turn the unit on or off.

9 ▶ FAN SPEED BUTTON

- Selects fan speeds in the following order: AUTO → LOW → MED → HIGH.
- **NOTE:** Hold down for 2 seconds to activate silent mode.

10 ▶ SWING BUTTON

- Starts and stops the horizontal louver movement.
- Hold down for 2 seconds to initiate louver auto vertical swing function.

11 ▶ SHORTCUT BUTTON

- Used to restore the current settings or resume previous settings.

12 ▶ TURBO BUTTON

- Enables unit to reach preset temperature in shortest possible time.

13 ▶ LED BUTTON

- Turns the air conditioner's buzzer on and off (depending model), which create a comfortable and quiet environment.

14 ▶ CLEAN BUTTON

- This function is used to clean the air conditioner's evaporator, to prevent frosting.

RCW11

Ref.: 7ACEL1774

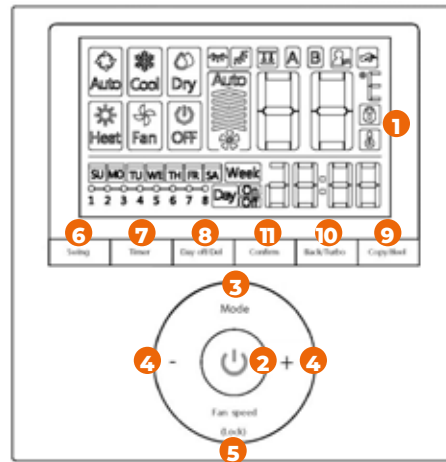

COMPATIBLE PRODUCTS

- FDMX (optional)
- DDMX
- CDMX (optional)

1 DISPLAY

Information is displayed when the remote control is on.	
	• Operating mode
	• Ventilation speed
	• Louver left/right position
	• Louver up/down position
	• Panel (not used)
	• Master/slave unit
	• "I Feel" function
	• Turbo or auxiliary heating mode
	• Degrees (°C/°F)
	• Temperature display
	• Remote control locking
	• Ambient temperature
	• Time display
	• Programming ON/OFF
	• Programming display

2 ON/ OFF BUTTON



• To start/stop use, press the ON/OFF button.

3 MODE SELECTOR BUTTON

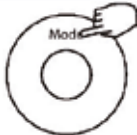

Press the MODE button to set the operating mode. (The HEAT function is not valid for a Cooling only type unit.)

	• Automatic. When this mode is selected, the air conditioner calculates the difference between the thermostat setting and the room temperature and automatically switches to "cooling" or "heating" mode.
	• Cooling. The air conditioner cools the room.
	• Dehumidify (dry mode). The air conditioner reduces the air humidity in the room.
	• Heating. The air conditioner heats the ambient air.
	• Ventilation only. The air conditioner circulates the air.
	• The air conditioner is off.

4 ▶ TEMPERATURE SETTING BUTTONS

- - (cooler). Reduce the set temperature.
- + (warmer). Increase the set temperature.

5 ▶ FAN SPEED SELECTION BUTTON



Press the button to set the ventilation speed.
(This button is not available in Auto or Dehumidify mode)

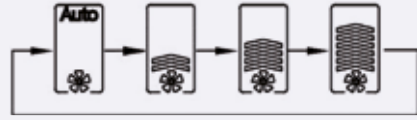

- Press the "Fan speed (Lock)" button for 3 seconds to activate the locking function and lock all the buttons on the wired remote control.

6 ▶ VERTICAL/HORIZONTAL SWING BUTTON



- Press the "SWING" button to start the up/down flap movement.
- Press it again to stop it.
- When the function is activated, the icon appears.



- Keep pressing the "SWING" button to start the louver left/right movement.
- Press it again to stop it.
- When the function is activated, the icon appears.

7 ▶ TIMER BUTTON (PROGRAMMING)



WEEKLY programming

- Use this programming function to set the operating hours for each day of the week.



Programming ON



Programming OFF



Programming ON/OFF

- Use this programming function to start and stop the air conditioner.
- The timer is activated and the air conditioner starts, and stops when the set time has elapsed.

6+7 ▶ BUTTON BEEP FUNCTION

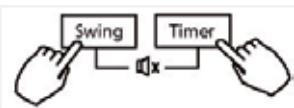

- Press the "SWING" and "TIMER" buttons simultaneously for 3 seconds to deactivate the button beep.

8 ▶ DAY OFF/DEL BUTTON



This button has 2 functions:

- The DAY OFF function: press this button to set the day on which the air conditioner will shut down due to absence.
- The DEL function: to cancel the time, mode, temperature and fan speed.

9 ▶ "I FEEL" BUTTON FOR ROOM TEMPERATURE DETECTION AND DISPLAY



- Activates temperature detection in the vicinity of the remote control. This function is available in AUTO, COOL and HEAT mode.
- When the "I Feel" icon the room temperature in the vicinity of the wired remote control is detected.

Copy/hold

- When programming, this button copies the setting for one day to another day.

10 ▶ TURBO BUTTON



- Press the "BACK/TURBO" button to activate/deactivate the Turbo/Auxiliary heating function.
- The BACK function: when programming, this button allows you to go back a step.

10 ▶ BOUTON CONFIRM



- Confirms the programmed action.

ALARM CODE MANAGEMENT

A malfunction code indicates the error code, which may be useful for servicing purposes.

N°	Alarm code explanation	Display
1	• Communication error between the remote control and the indoor unit.	F0
2	• The board is faulty.	F1

RCW26

Ref.: 7ACEL1876

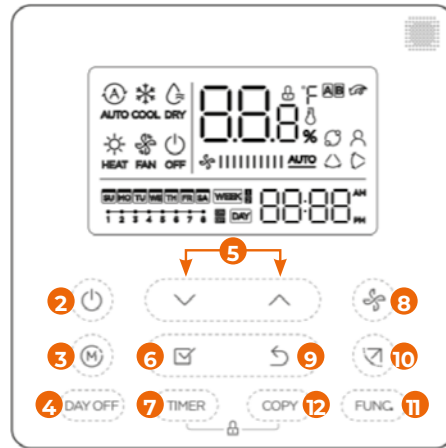

COMPATIBLE PRODUCTS

- FDMX (optional)
- DDMX (optional)
- CDMX (optional)



To connect the remote control to the systems from sizes FDMX 070, DDMX 070, CDMX 070, **you need to order one 7ACEL1776 interface for each indoor unit.**

1 ► DISPLAY

Information is displayed when the remote control is on.	
	Operation mode indication
	Fan speed indication
	Temperature display
	Lock indication
	°C / °F indication
	Main unit and secondary unit indication
	Turbo function indication
	Room temperature indication
	Rotating indication
	Follow Me function indication
	Left-right swing indication (some models)
	Clock display
	On/Off timer
	Timer display

2 ► POWER BUTTON

- To start/stop use, press the ON/OFF button.

3 ► MODE BUTTON

Press the Mode button to select the operating mode (the heating function is invalid for cooling-only units).

	• Auto
	• Dehumidify
	• Heating
	• Fan
	• Cooling

4 ▶ DAY OFF/DEL BUTTON

- During the weekly timer, pressing the Del button once, display "0h".
- Press this button twice, display "1h" and wait 3 seconds to confirm. It means the unit will override 1 hours.
- Press this button three times, display "2h" and wait 3 seconds to confirm. It means the unit will override 2 hours.

5 ▶ ADJUST BUTTON

- This button allows you to adjust the temperature as well as scroll through the different functions.

6 ▶ CONFIRM BUTTON

- Press once to confirm your choices during programming.

7 ▶ TIMER BUTTON

WEEKLY TIMER

- Use this timer function to set operating times for each day of the week.

ON TIMER

- Use this timer function to start air conditioner operation.

OFF TIMER

- Use this timer function to stop air conditioner operation.

ON AND OFF TIMER

- Use this timer function to start and stop air conditioner operation.

8 ▶ FAN SPEED BUTTON

- Press the Fan speed button to set the fan speed.

9 ▶ BACK BUTTON

- It allows you to go back when programming or choosing a mode.

10 ▶ SWING BUTTON

- Use the Swing button to adjust the direction of the flaps.

11 ▶ FUNCTION BUTTON

TURBO

- Under COOL/HEAT mode, press the FUNC. Button to activate the turbo function. Press the button again to deactivate the turbo function. When the turbo function is activated, the  mark appears.

ROTATION

- When there are two units, press the button to select the rotating function, and press "Confirm" to turn on or off the rotating function.

FOLLOW ME

- Press the FUNC. button to select whether the room temperature is detected at the indoor unit or the wire controller.

12 ▶ COPY BUTTON

- Copy out the setting in one day into the other day. A reservation made once can be copied to another day of the week. The effective use of the copy mode ensures ease of making reservations.

MORE FUNCTIONS

POWER OFF MEMORY

- After a power failure, the RCW26 remote control restores the previous operating modes.

CHILD LOCK

- This function can lock the RCW26 wired controller and prevent erroneous or mischievous setting change.

REMOTE CONTROL COMPATIBLE

- With Infrared Receiver built-in, RCW26 wired control can receive the signals from remote controller and realize conventional functions.

FOLLOW ME

- The wired remote control RCW26 has an integrated temperature sensor.
- The Follow-Me button activates this sensor, which detects and adjusts the room temperature to ensure a better comfort.

OTHERS

- Redundancy and operating time balancing.
- 4 choices of operating mode: - All modes,
 - Heating / Ventilation,
 - Cooling / Dehumidification / Ventilation,
 - Cooling / Heating / Dehumidification / Ventilation.
- Minimum and maximum setpoint temperature limits.
- 2 two-way remote controls for large areas.
- Adjustable backlighting time.
- Equipped with an infrared receiver.

RCW27

Ref.: 7ACEL1874

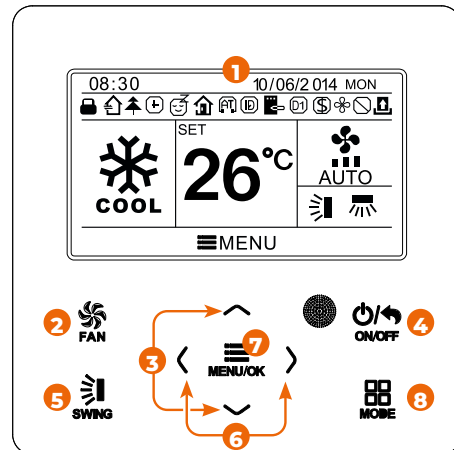

COMPATIBLE PRODUCTS

- HDLE Aura (optional)
- XDLF (optional)

1 ► DISPLAY

Information is displayed when the remote control is on.	
Operating mode	• Vertical swing function
	• Lateral swing function
	• FRESH AIR function
	• SLEEP function
	• AUTO mode
	• COOLING mode (air conditioning)
	• DRY mode
	• FAN mode
	• HEATING mode
	• HEALTH function (purification)
	• I-DEMAND function
	• AWAY function
	• Locking function (buttons, temperature, ON/OFF, mode and energy saving are locked by the remote display)
	• Current set fan speed
	• MEMORY function (in case of power failure)
	• DRED function
	• SAVE function (energy saving)
	• X-FAN function (turbo fan)
	• Timer Enabled Status
	• Door card removed or no-one present status
• QUIET function	
• Function lock	

2 ► FAN SPEED SELECTION BUTTON

Press the button to adjust the fan speed.

LOW, MEDIUM, HIGH, TURBO and AUTO.

3 ► TEMPERATURE SETTING BUTTONS

- (warmer). Raises the set temperature.
- (cooler). Lowers the set temperature.

Notes: - In AUTO mode, the set temperature cannot be adjusted.
 - and also allow you to set the parameters and move the option slider.

4 ▶ ON/OFF/BACK OPERATION BUTTON

- To start/stop use, press the ON/OFF button.

5 ▶ SWING BUTTONS

Press this button to change mode.

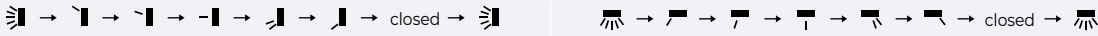

- Use to swing the air supply louver in various vertical and lateral positions.

6 ▶ FUNCTION SETTING BUTTONS

- and activate or deactivate the corresponding function.
- Notes:** Also used to set settings and move the option slider.

7 ▶ MENU/OK BUTTON

Press this button to change mode.

Setting the FRESH AIR function

- Press the or button to select the FRESH AIR function then press or to activate or deactivate this function. Press the MENU button to set FRESH AIR mode. After entering the FRESH AIR mode setting, press the or button to set the mode in the range 1-10.
- When the setting is complete, press the MENU button to save the setting.

Setting the SLEEP function

- Press the or button to select the SLEEP function then press or to activate or deactivate the SLEEP function with automatic save.
- If this feature is enabled, the unit operates from a preset sleep curve to provide a comfortable sleeping environment.

Notes:

- In FAN (fan) or Auto mode, the SLEEP function is not available.
- The SLEEP function can be canceled by turning off the unit or changing the mode.

Setting the HEALTH function

- Press the or button to select the HEALTH function then press or to activate or deactivate this function with automatic save.

Setting the I-DEMAND function

- Press the or button to select the I-DEMAND function then press or to activate or deactivate this function with automatic save.

Notes:

- This function is only available in COOLING mode.
- After this function is set, the set temperature displayed in SE. In this case, the temperature and fan speed settings are locked.
- This function is canceled by changing the mode.
- This function and the SLEEP function cannot be activated simultaneously. If the I-demand function is set first and then the SLEEP function, the first will be canceled and the second valid, and vice versa.

Setting the HOLIDAY function

- Press the or button to select the HOLIDAY function then press or to activate or deactivate this function with automatic save.
- This function is used to maintain the indoor temperature so that the unit can heat up quickly.

Notes:

- This function is only available in HEATING mode.
- When this function is set, the set temperature displayed is 8°C (46°F). In this case, the temperature and fan speed settings are locked.
- This function is canceled by changing the mode.
- This function and the SLEEP function cannot be activated simultaneously. If the Holiday function is set first and then the SLEEP function, the first will be canceled and the second valid, and vice versa.

Setting the MEMORY function

- Press the or button to select the MEMORY function then press or to activate or deactivate this function with automatic save.

Setting the FIXED-ANGLE SWING mode

- Press the or button to select the LOCKED SWING function then press or to activate or deactivate this function with automatic save.

Notes: If the FIXED ANGLE SWING function is not available for the connected unit, this function will be automatically canceled after setting.

Setting the SAVE function

- Press the or button to select the SAVE function then press or to activate or deactivate this function. Press the MENU button to enter the SAVE function setting page.
- After entering the SAVE function setting page, press the or button to select the cooling and heating limit temperature. After selecting the cooling and heating limit temperature, press the or button to adjust the limit temperature value. When the setting is complete, press the MENU button to save the setting.

Notes: Once the SAVE function has been set, it is not possible to set the AUTO mode.

Setting the AUXILIARY HEATING function

- Press the or button to select the AUXILIARY HEATING function then press or to activate or deactivate this function with automatic save.

Setting the X-FAN function

- Press the or button to select the DRY function, then press or to activate or deactivate this function with automatic save.

Notes: This function is only available in COOLING and DRY mode.

Setting the QUIET function

- Press the or button to select the QUIET function, then press or to activate or deactivate this function with automatic save.

Notes: This function is only available in COOLING, HEATING and AUTO mode.

Setting FAHRENHEIT TEMPERATURE

- Press the or button to select the FAHRENHEIT TEMPERATURE function, then press or to activate or deactivate this function with automatic save. Once this function is closed, the temperature will appear in Celsius.

Setting the AIR function

- Press the or button to select the AIR function, then press or to activate or deactivate this function. Press the MENU button to set the AIR function mode. After entering the AIR function mode setting, press the or button to set the mode in the range 1-2.
- When the setting is complete, press the MENU button to save the setting.
- Each mode is equivalent to the following: 1. Suction/2. Exhaust.

8 ▶ MODE SELECTION BUTTON

Press this button to change mode.



- **Automatic.** When this mode is selected, the air conditioner calculates the difference between the thermostat setting and the room temperature and automatically switches to COOLING or HEATING mode.



- **Cooling.** The air conditioner cools the room.



- **Dehumidification (drying).** The air conditioner dries the air in the room.



- **Fan only.** The air conditioner circulates air.



- **Heating.** The air conditioner heats the ambient air.

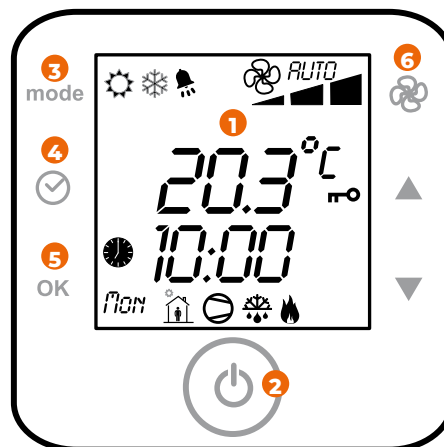

COMPATIBLE PRODUCTS

- DFMO

1 ► DISPLAY

Information is displayed when the remote control is on.	
	• Operating mode: SUMMER
	• Operating mode: WINTER
AUTO	• Operating mode: AUTOMATIC
	• Exhaust fan speed
	• Alarm present
	• Keypad locked
	• Time bands active if the clock is visible
	• Time band active
	• Compressor active
	• Defrosting in progress
	• Auxiliary heater (Electrical resistors, hot water coil)

2 ► ON/ OFF BUTTON

- To start/stop use, press the ON/OFF button.

3 ► MODE SELECTOR BUTTON

Press this button to change the mode.	
	• Summer/Cooling. The air conditioner cools the room.
	• Winter/Heating. The air conditioner heats the ambient air.
AUTO	• Automatic. When this mode is selected, the air conditioner calculates the difference between the thermostat setting and the room temperature and automatically switches to cooling or heating mode.

It is possible to modify the operating setpoint at any time using the ▲▼ buttons.

4 ► CHANGING THE TIME OR DAY

- Press the CLOCK button for 5 sec.
- Using the ▲▼ buttons select the CLOCK menu
- Confirm with the OK button
- The time flashes: adjust using the ▲▼ buttons
- Confirm with the OK button
- Repeat the procedure for the minutes and the day of the week
- To return to the main screen, select the "Esc" menu and confirm with OK

4+5 ► ON/ OFF BUTTON

- Press for 5 seconds to LOCK/UNLOCK the buttons.

ECONOMY SETPOINT





The ECO setpoint is optimised to reduce energy consumption:













- In summer: the ECO set point is higher than the standard setpoint.
- In winter: the ECO set point is lower than the standard setpoint.

PROGRAMMING TIME BANDS

4 types of programming are possible:

- 7 days (Monday to Sunday)
- 5 days (Monday to Friday)
- 2 days (Saturday to Sunday)
- Day by day

Daytime programming		Night-time programming	
	• Inside		• Inside
	• Outside		• Outside
	• Back home		• Back home

PROGRAMMATION JOUR PAR JOUR			
	1 Press  for 5 seconds		8 Select the next time band using ▲ Press OK Repeat the procedure
	2 Select "TIME BANDS" using ▲▼ Press OK		9 Select "ESC" using ▲▼ Press OK
	3 Select "DAY BY DAY" using ▲▼ Press OK		10 Press OK to programme the next day
	4 Press OK		11 Select the next day using ▲▼ Press OK Repeat the procedure
	5 Display the hour using ▲▼ Press OK		9 Select "ESC" to exit using ▲▼ Press OK
	6 Display the minutes using ▲▼ Press OK		13 Select "ESC" to exit using ▲▼ Press OK
	7 Display the temperature using ▲▼ Press OK		

PROGRAMMING ON/OFF

	1 Press  to deactivate time band programming		2 Programming deactivated: symbol hidden 
---	--	---	---

ALARMS

- Any malfunctions are indicated on the display by the ALARM icon. Before resetting an alarm, identify and remove the cause that generated it.
- Repeated resets can cause irreversible damage such as a system malfunction.

To reset a present alarm:

- Press Mode + Clock for 5 sec.

PARAMETERS

The configuration parameters are password protected to avoid unintentional changes which might affect the operation of the unit.

To access the parameters:

1. Press ON/OFF + FAN for 5 seconds
2. Enter the password: using the ▲▼ buttons. Code = 2
3. Confirm with OK
4. Select the PAR menu and confirm with OK
5. Scroll through the list ▲▼
6. Select the parameter with OK
7. Change the value ▲▼ and confirm with OK
8. Scroll up to exit

For more details, refer to "PARAMETERS" section in the manual.

STATUSES

To access statuses:

- Press ON/OFF + FAN for 5 seconds.

WELLEA WT - Split heat pump with DHW tank included

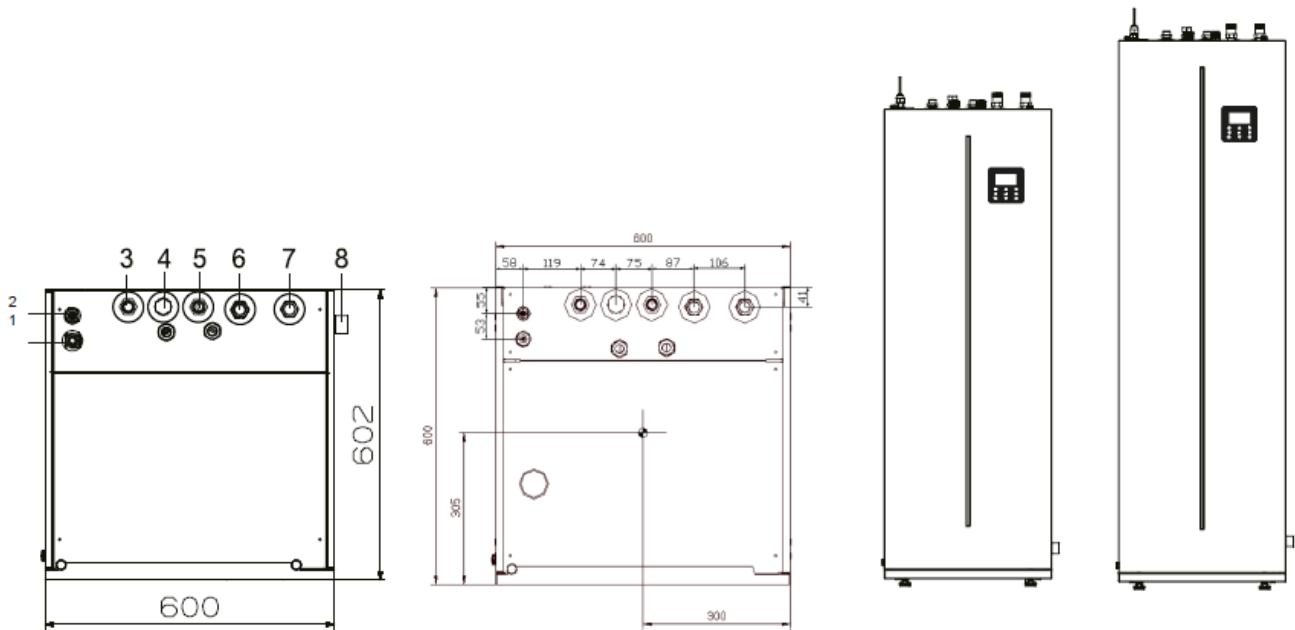

WELLEA SPLIT - Split heat pump

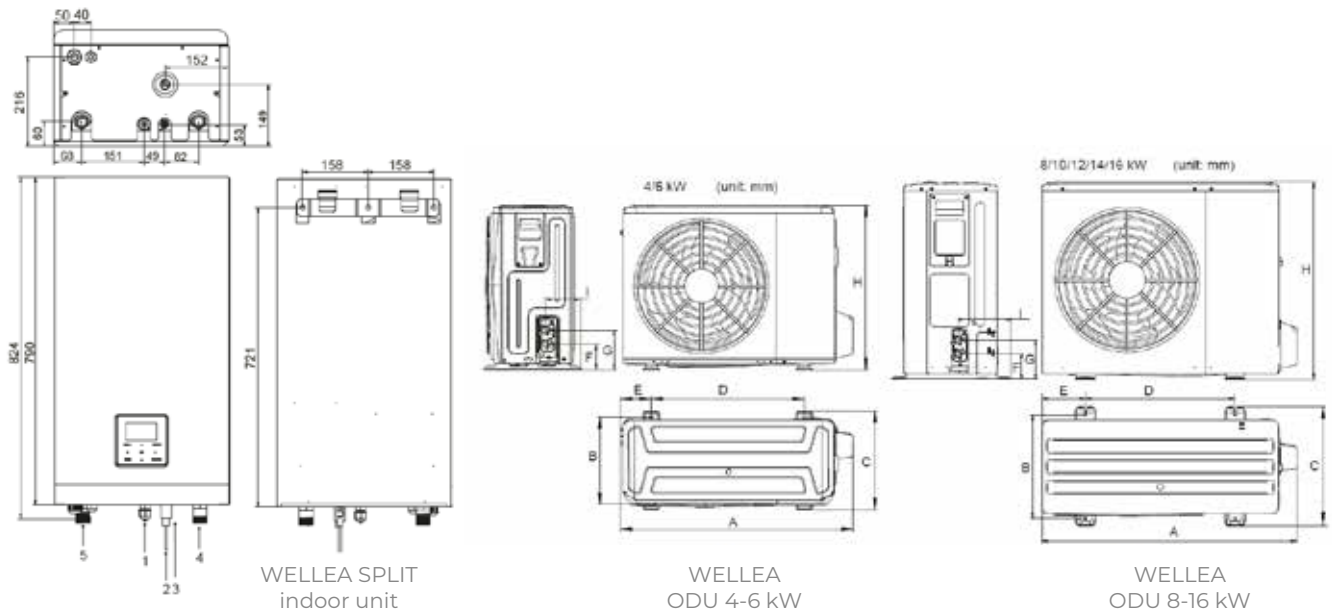

DIMENSIONS (mm)

MODEL	A	B	C	D	E	F	G	H	I
4/6 kW	1008	375	426	663	134	110	170	712	160
8/10/12/14/16 kW	1118	458	523	656	191	110	170	865	230

WELLEA MONOBLOCK - Monoblock heat pump

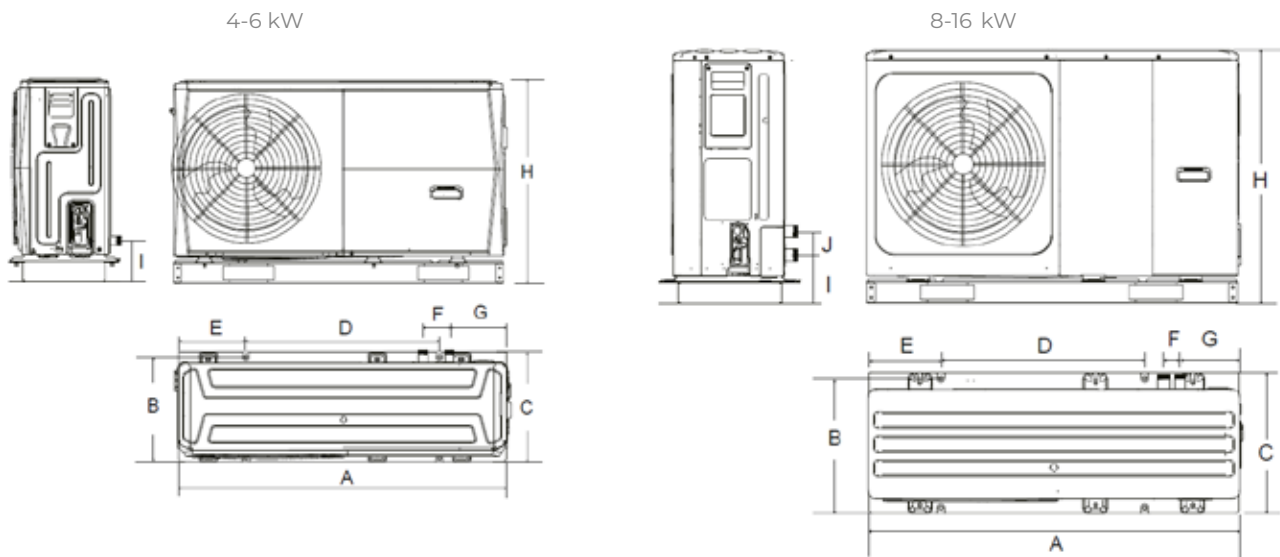

DIMENSIONS (mm)

MODEL	A	B	C	D	E	F	G	H	I	J
4/6 kW	1295	397	429	760	265	105	225	792	161	-
8/10/12/14/16 kW	1385	482	526	760	270	60	221	945	182	81

WELLEA MONOBLOCK DF - Monoblock heat pump

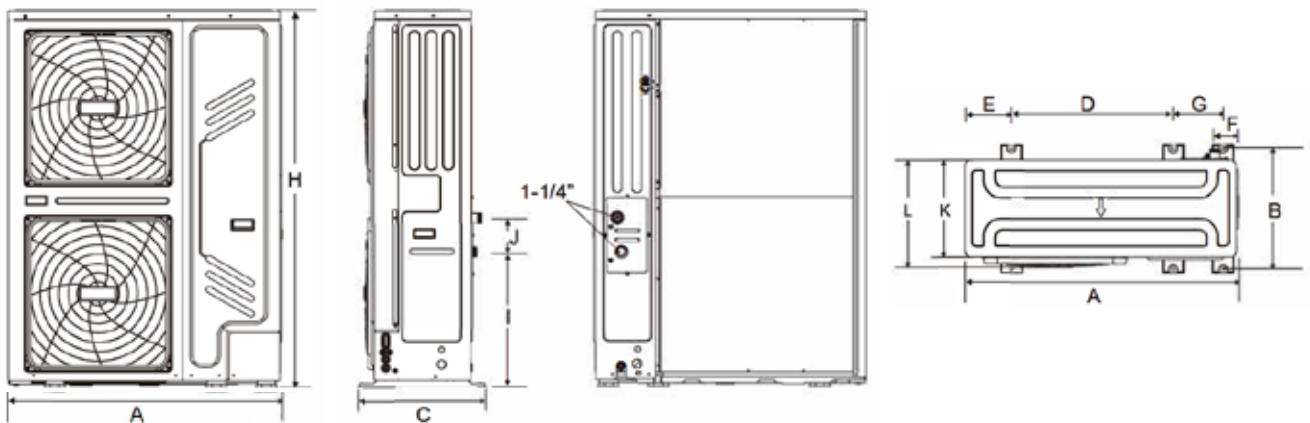

DIMENSIONS (mm)

MODEL	A	B	C	D	E	F	G	H	I	J	K	L
18/22/26/30 kW	1129	494	528	668	192	98	206	1558	558	143	400	440

TFHX ELEO / YFHX - Split thermodynamic water heater

Indoor unit TFHX

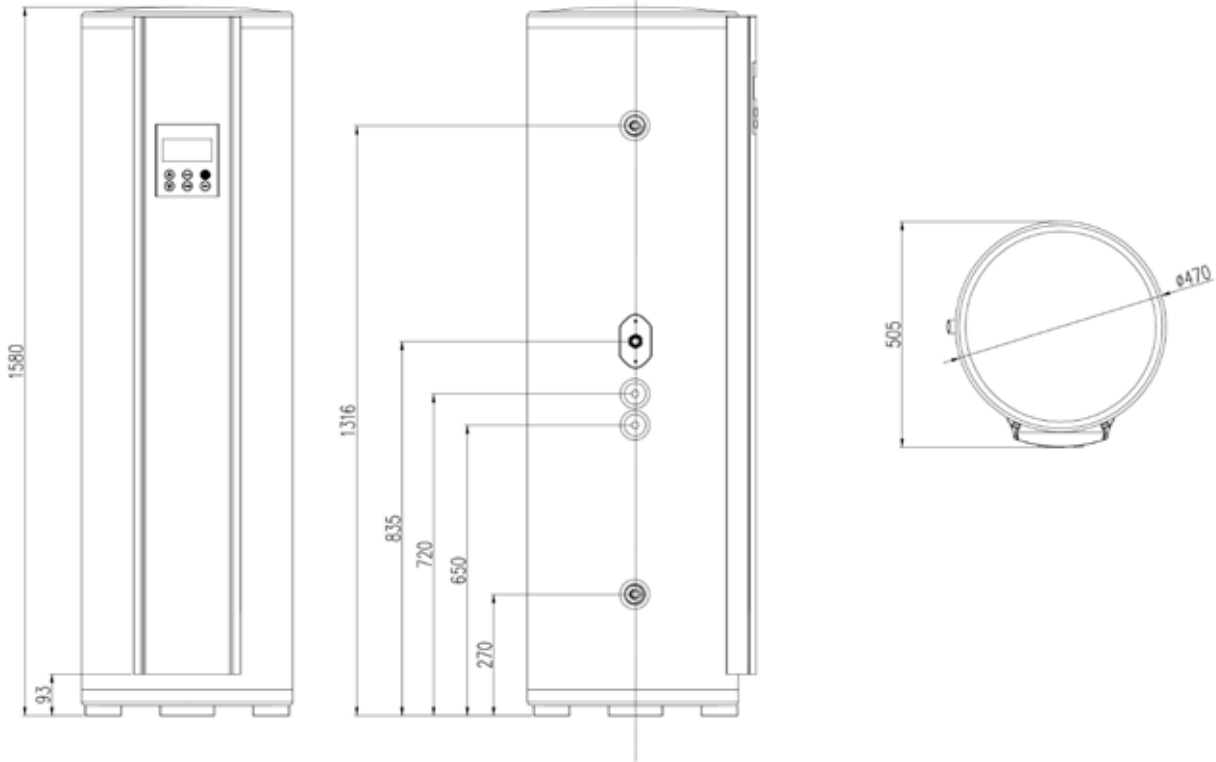

Outdoor unit YFHX

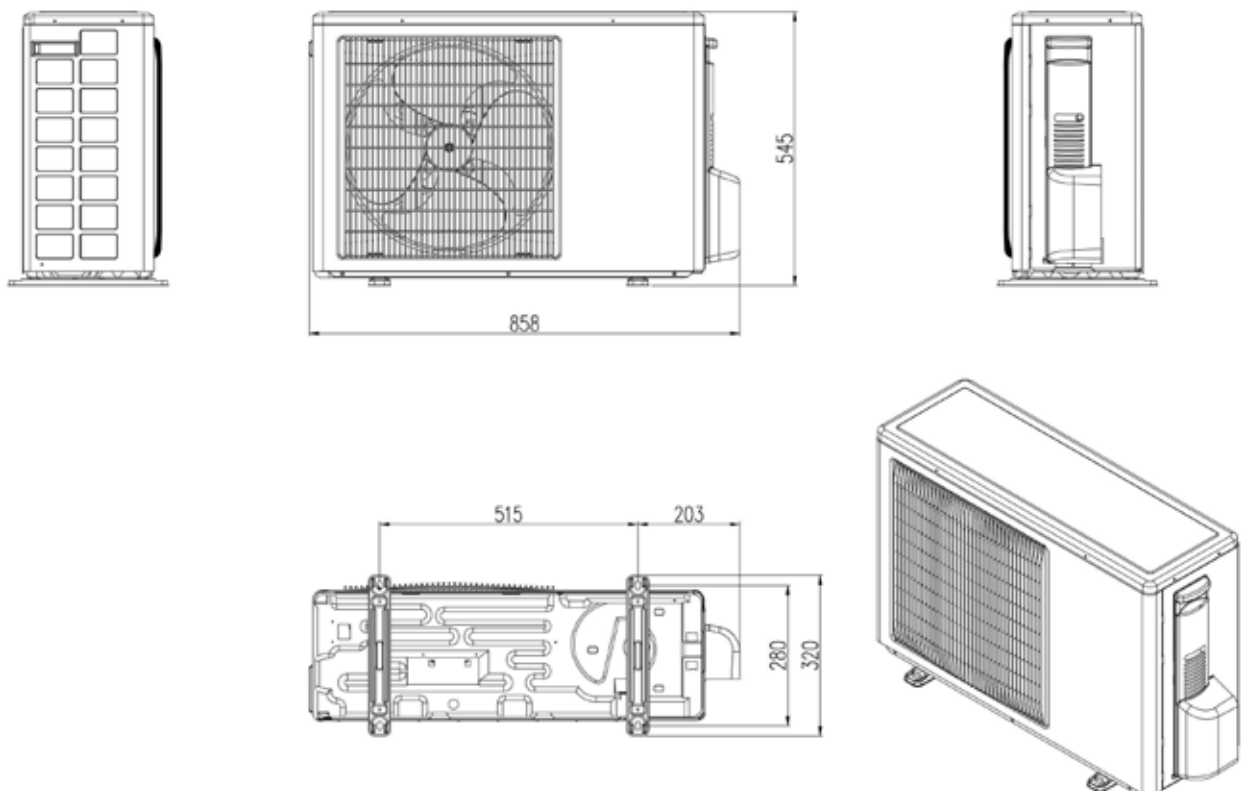

TFHW ELEO - Monoblock thermodynamic water heater

120L

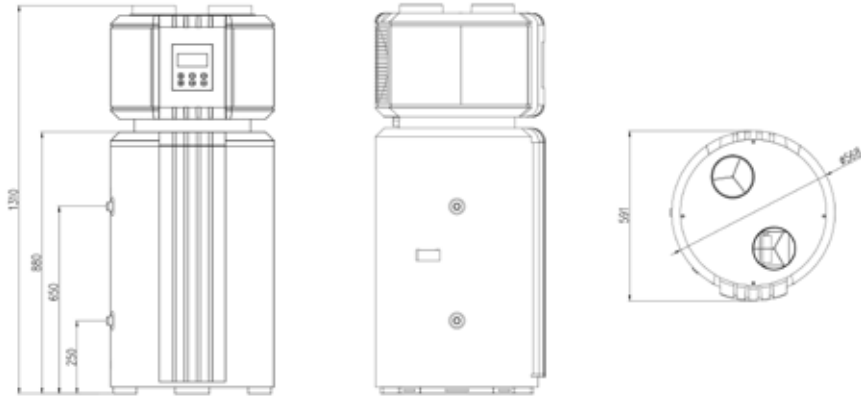

190L

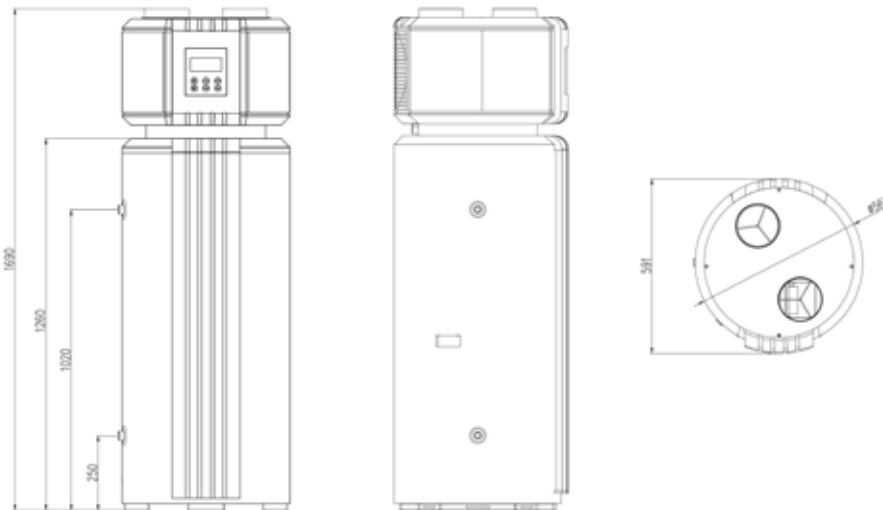

260L

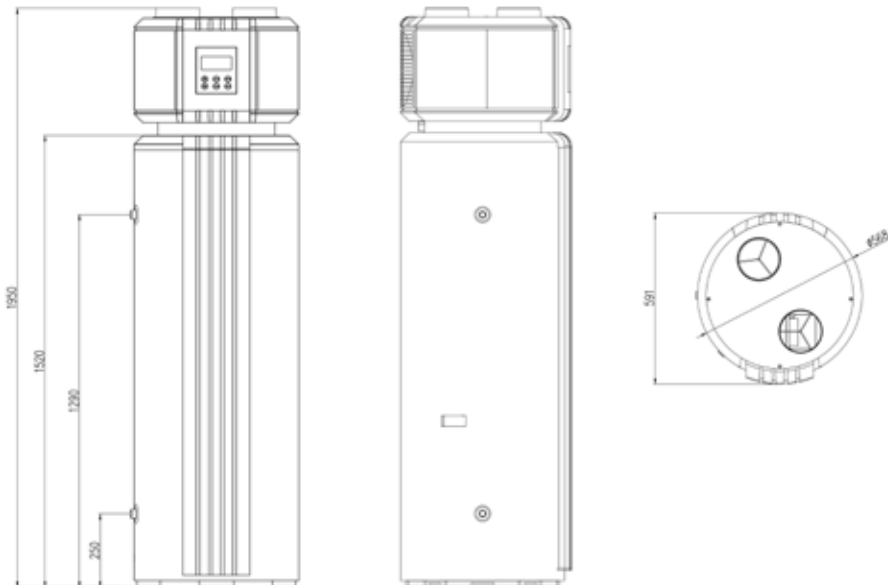

TFHZ ELEO - Solar thermodynamic water heater

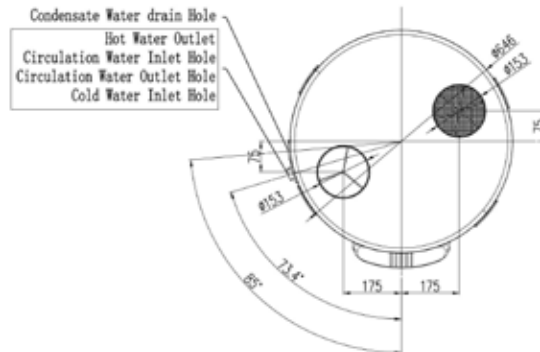
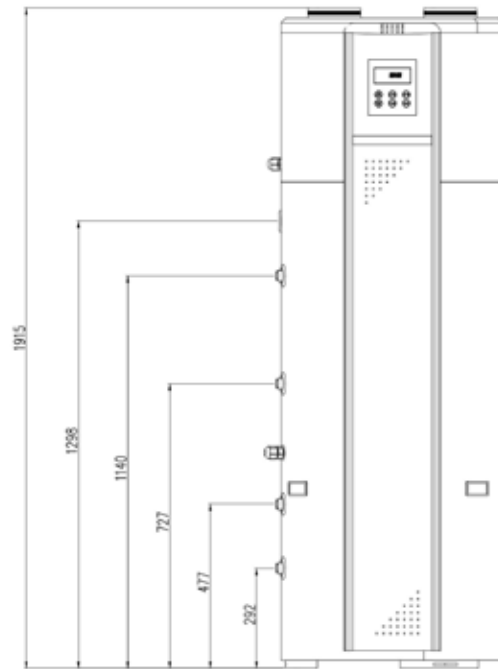

HDHC Artica / YDAC - High wall

HDHC Artica

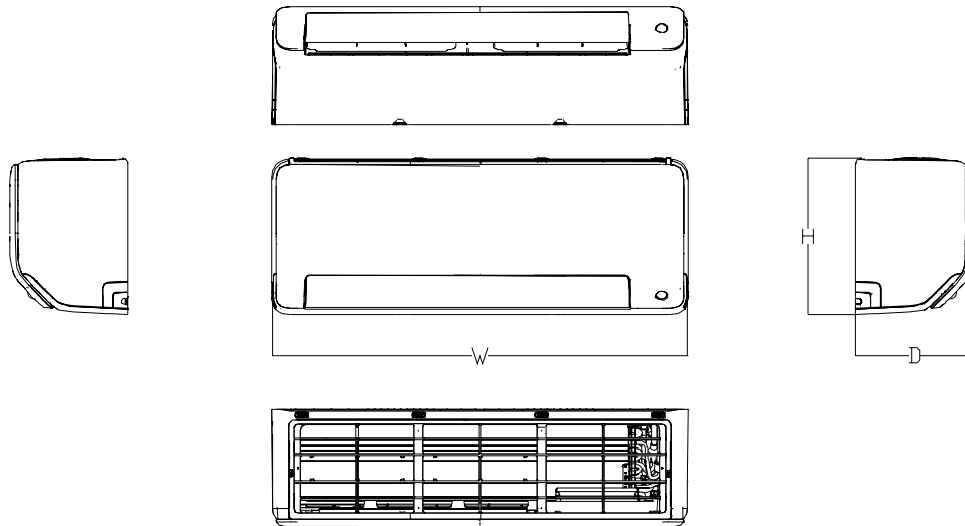

DIMENSIONS (mm)

MODEL	W	D	H
025N-035N	795	225	295
050N	965	239	319
070N	1140	275	370

YDAC 025R-035R

YDAC 050R-070R

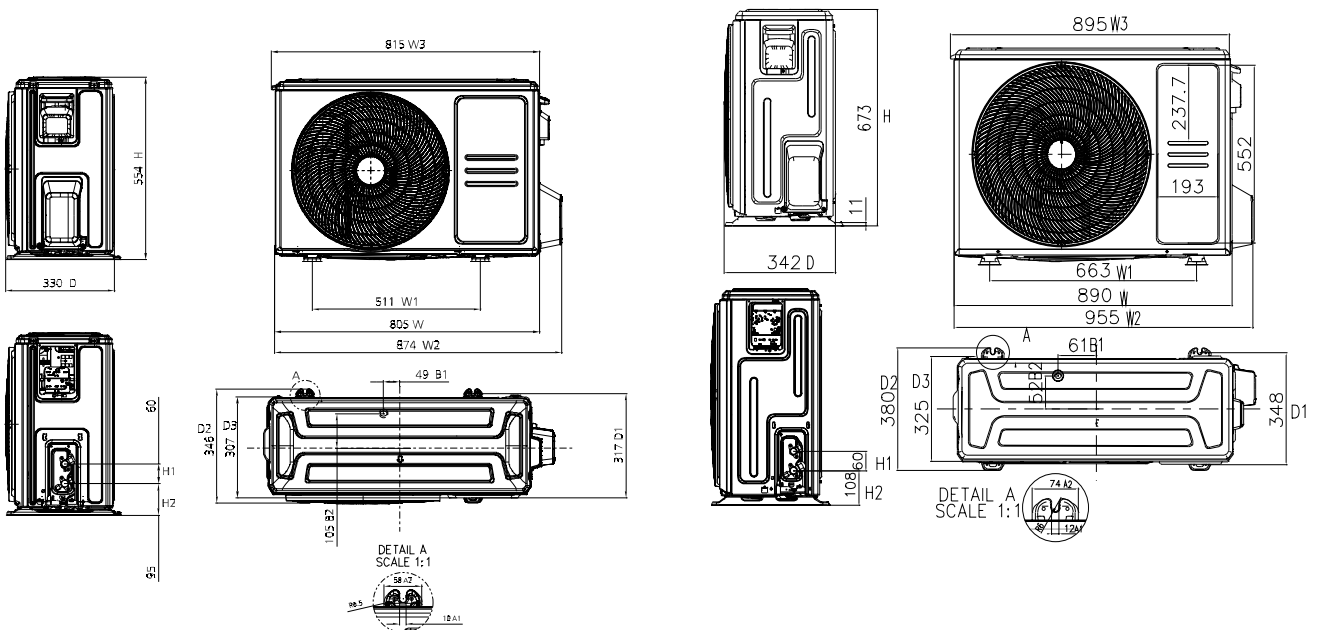

HDMB HARMONIA Colour range / YDAB - High wall

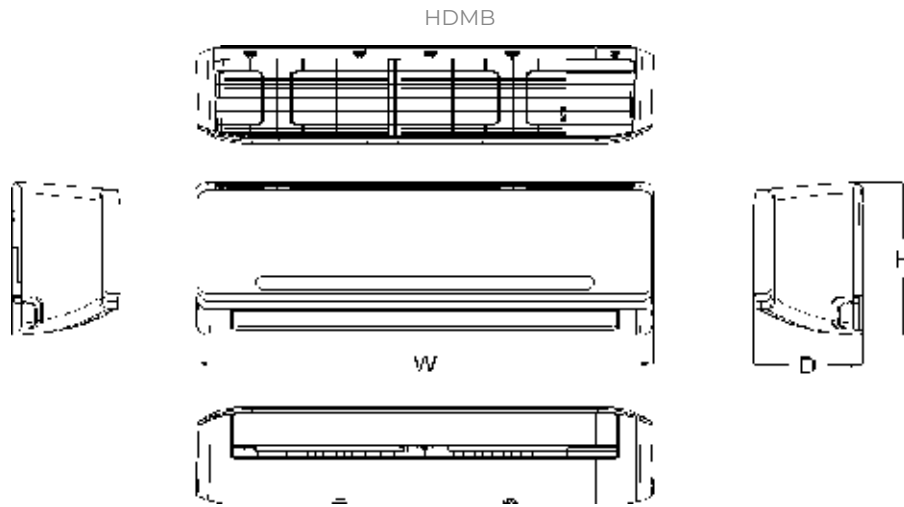

DIMENSIONS (mm)

MODEL	W	D	H
025N-035N	802	189	297
050N	965	215	319
070N	1080	226	335

YDAB 025H-035H

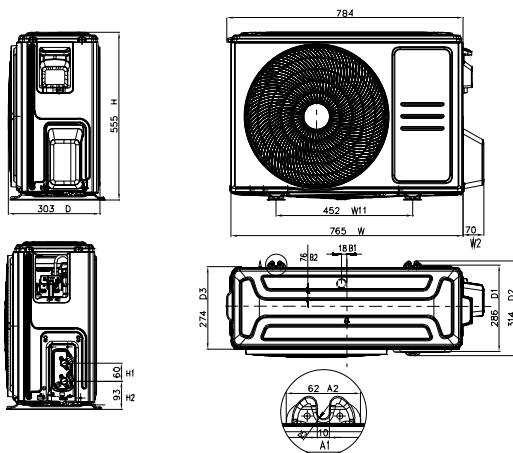

YDAB 050H

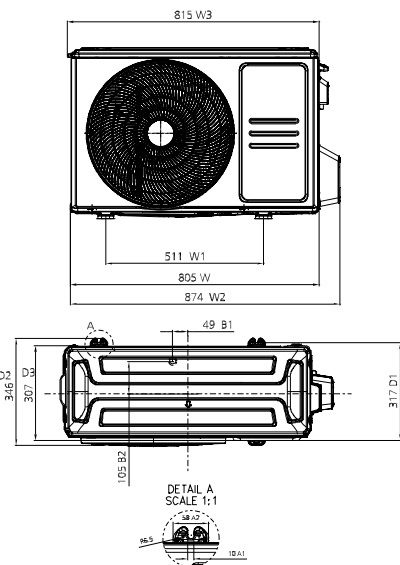

YDAB 070H

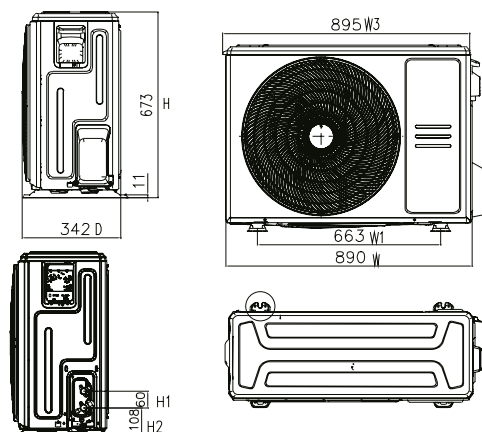

HDLA / YDAA - High wall

HDLA

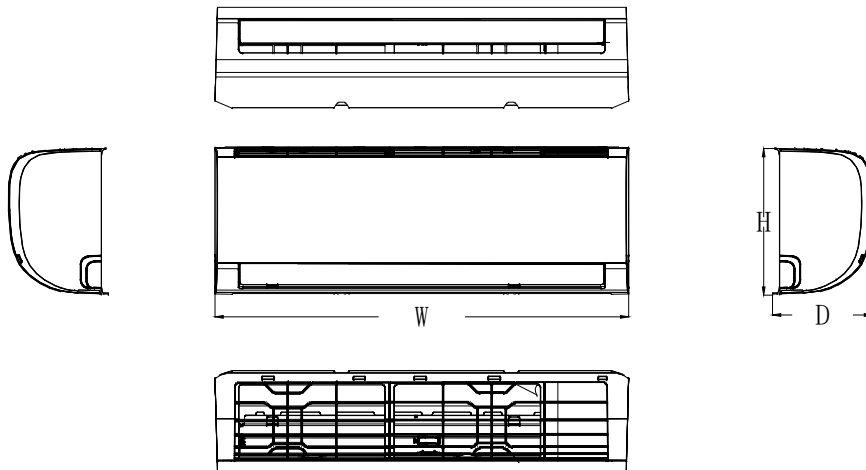

DIMENSIONS (mm)

MODEL	W	D	H
022N-025N-035N	805	194	285
050N	957	213	302
070N	1040	220	327

YDAA-025H/-035H-09M25

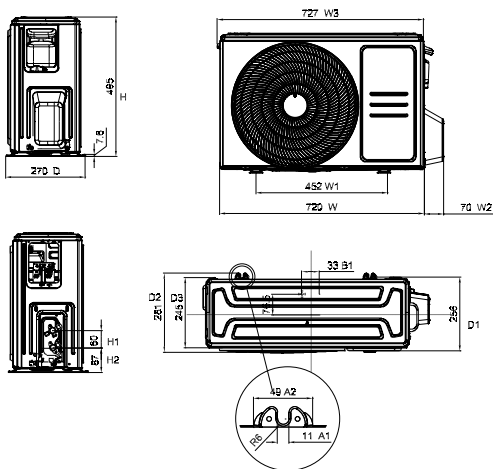

YDAA-050H-09M25

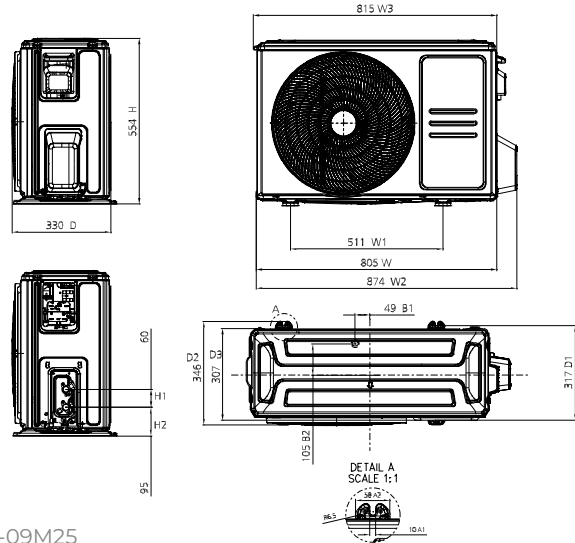

YDAA-070H-09M25

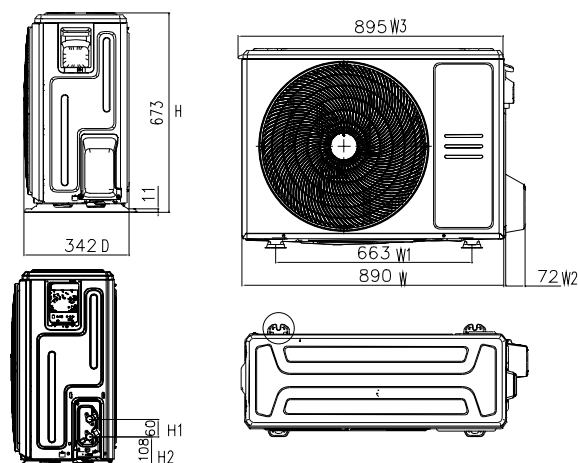

HDLE / YDAE - High wall Built-in Wi-Fi

HDLE

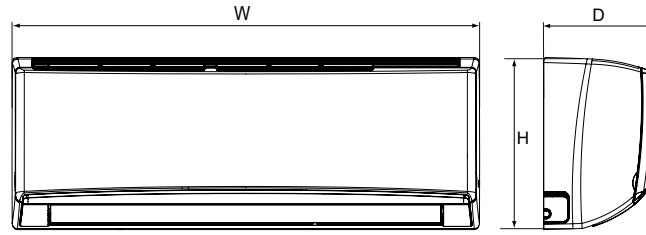

HDLE-025N-09M25
HDLE-035N-09M25

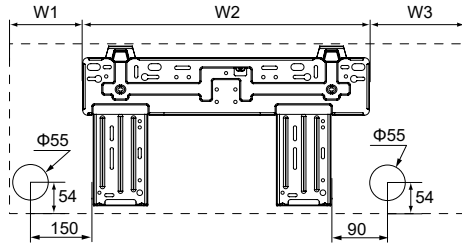

HDLE-070N-09M25

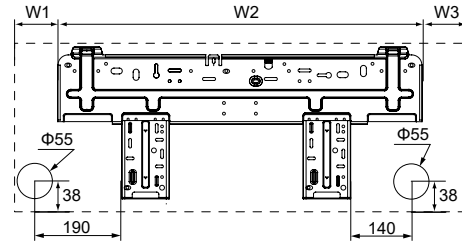

DIMENSIONS (mm)

MODEL	W	H	D	W1	W2	W3
HDLE-022N-09M25	713	270	195	148	462	103
HDLE-025N-09M25 HDLE-035N-09M25	790	275	200	168,5	462	159,5
HDLE-070N-09M25	970	300	224	104	685	181

YDAE-022R

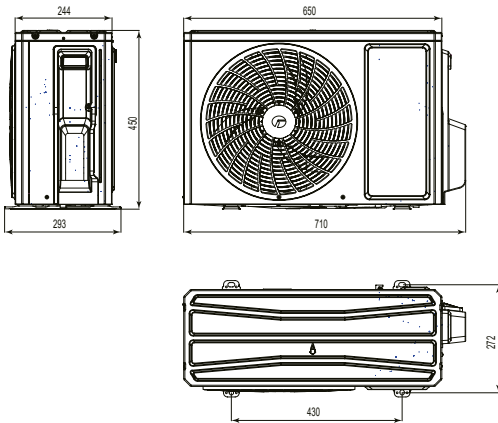

YDAE-050R

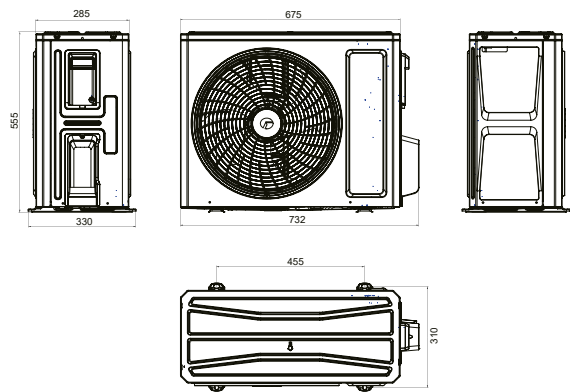

YDAE-025R/035R

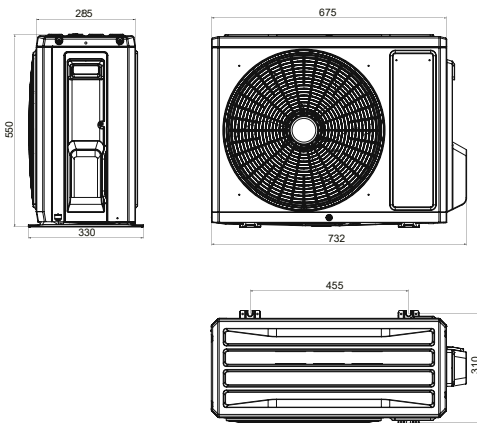

YDAE-070R

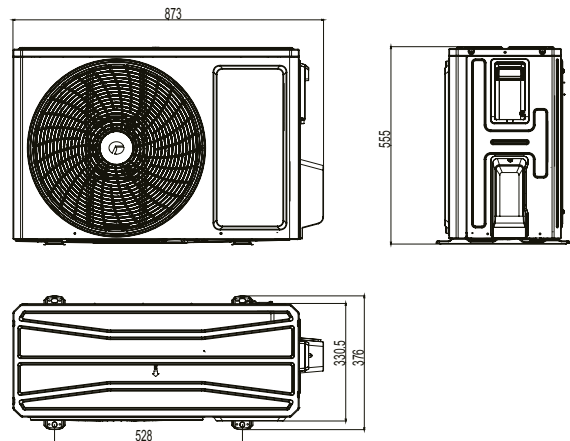

ZDAA - Multisplit

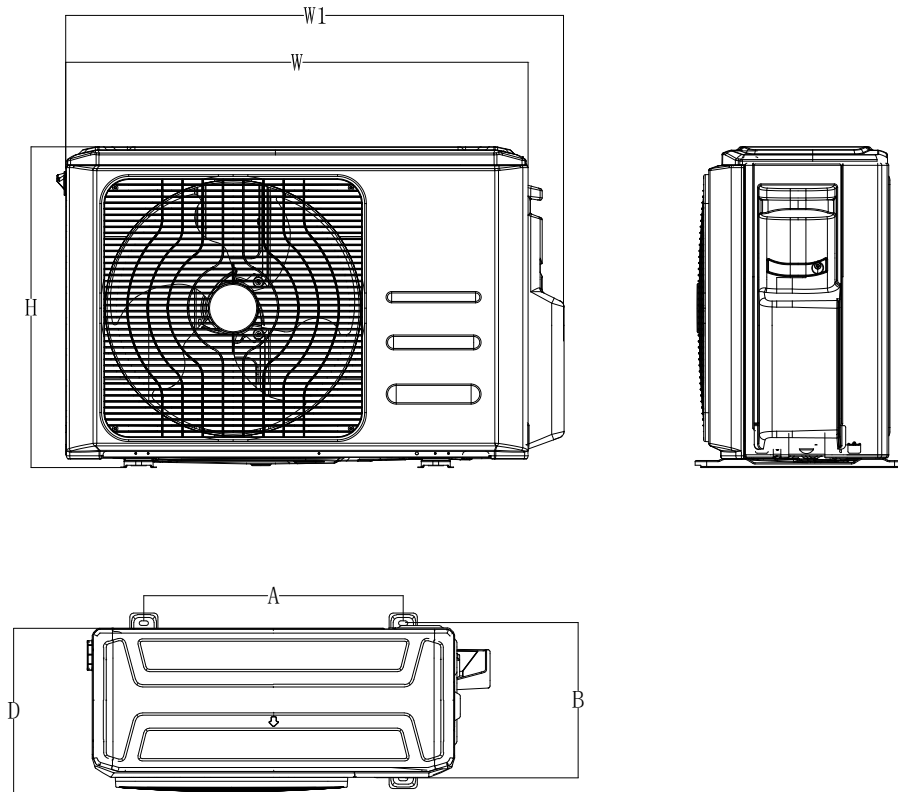

DIMENSIONS (mm)

MODEL	W	D	H	W1	A	B
ZDAA-2040-09M25	805	330	554	877	511	317
ZDAA-2050-09M25	805	330	554	877	511	317
ZDAA-3080-09M25	890	342	673	990	663	354
ZDAA-4090-09M25	946	410	810	1034	673	403
ZDAA-5130-09M25	946	410	810	1034	673	403

ZDAE - Multisplit

ZDAE 2040-2050

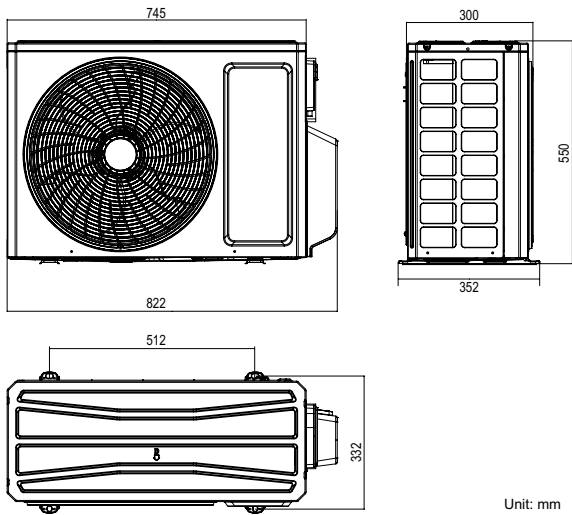

Unit: mm

ZDAE 3060-3070-4080

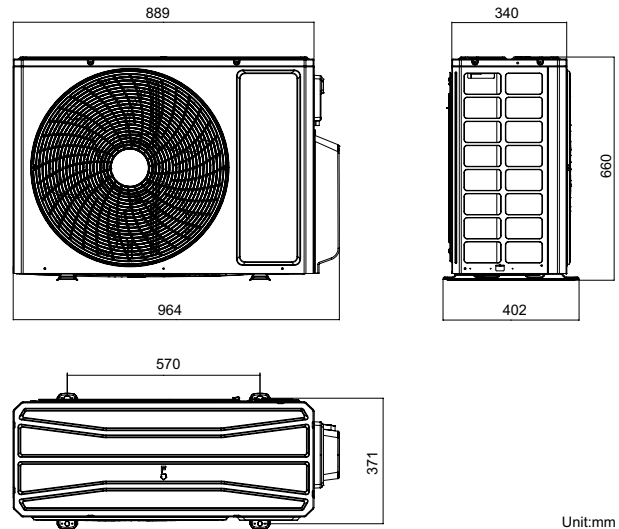

Unit:mm

ZDAE 5130

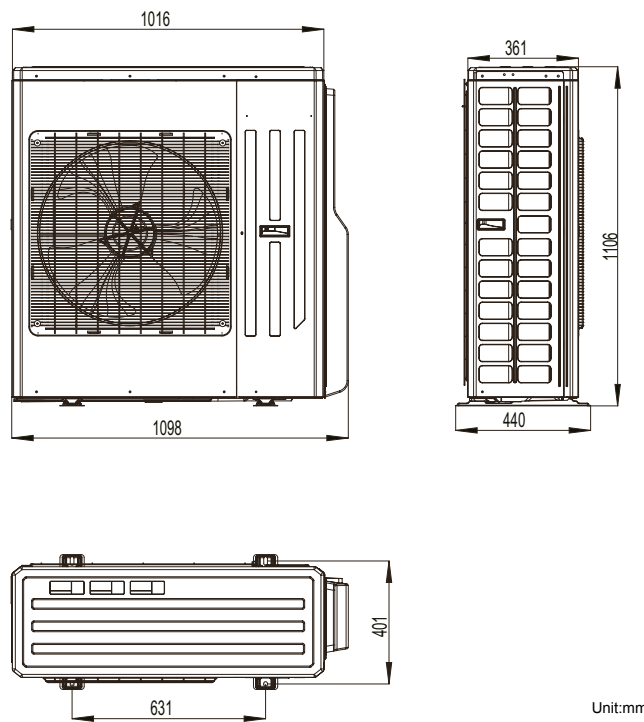

Unit:mm

XDLF / YDAF - Dual-flow console

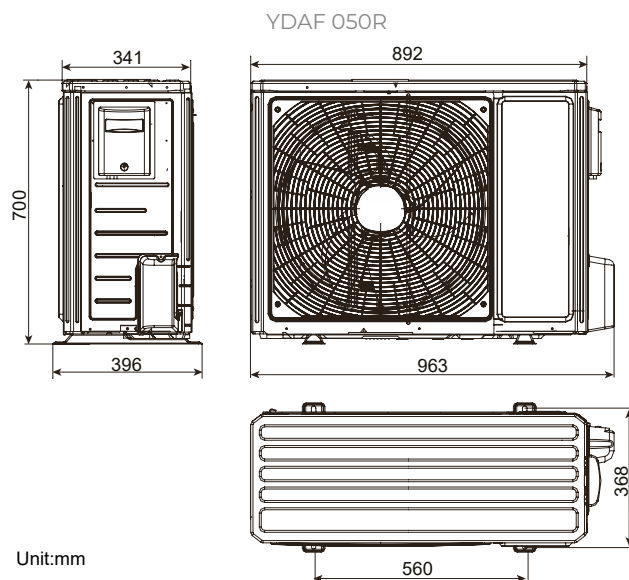
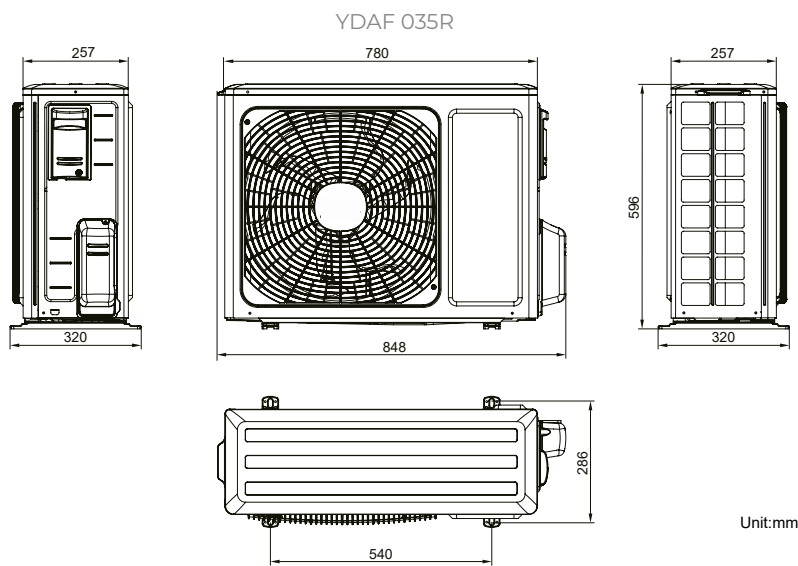
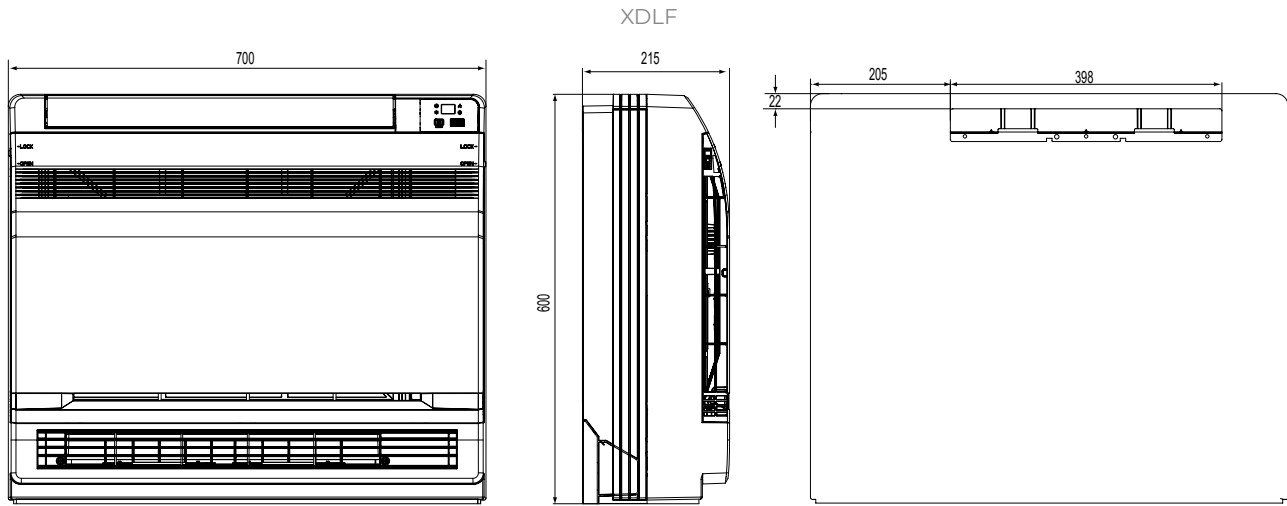

XDMX - Dual-flow console

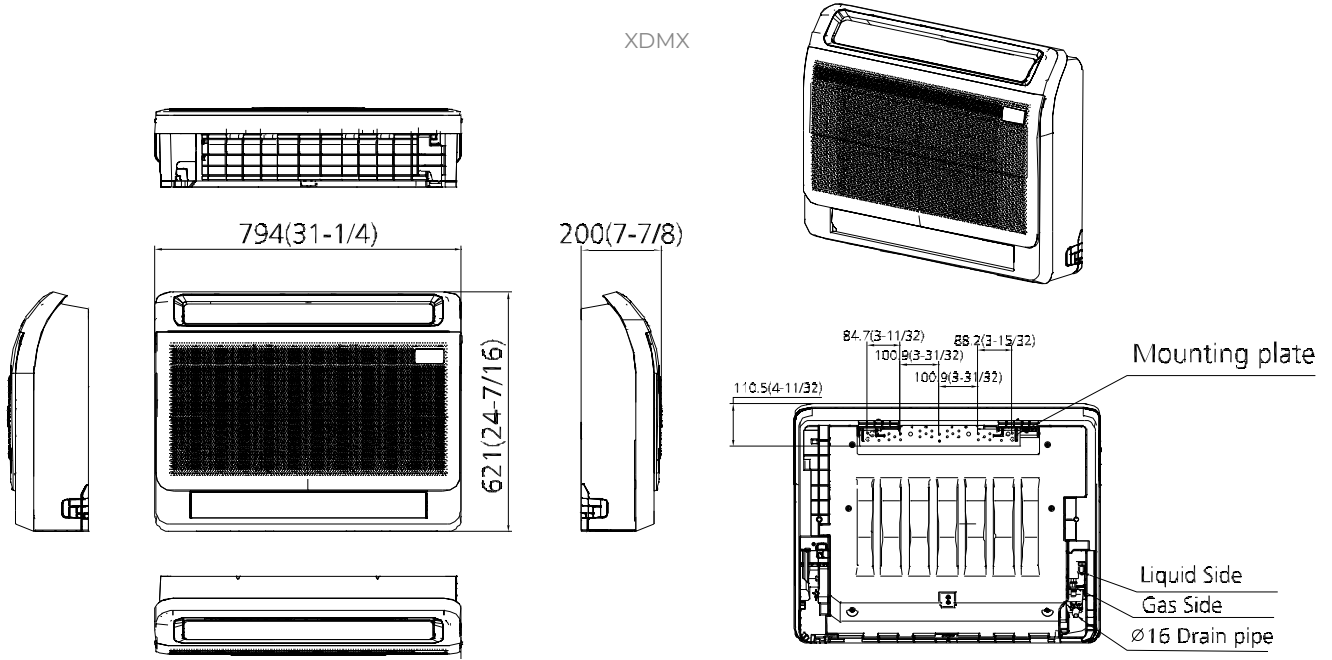

FDMX - Floor ceiling

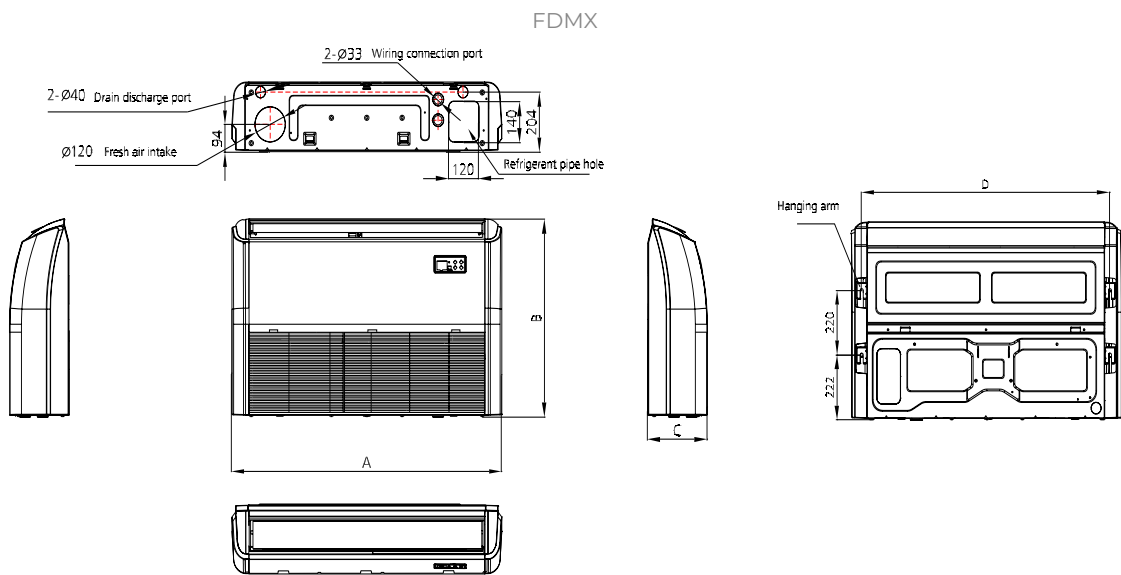

DIMENSIONS (mm)

MODEL	A	B	C	D
050N-070N	1068	675	235	983
100N-140N-175N	1650	675	235	1565

FDLK / YDAK - Low-temperature floor ceiling

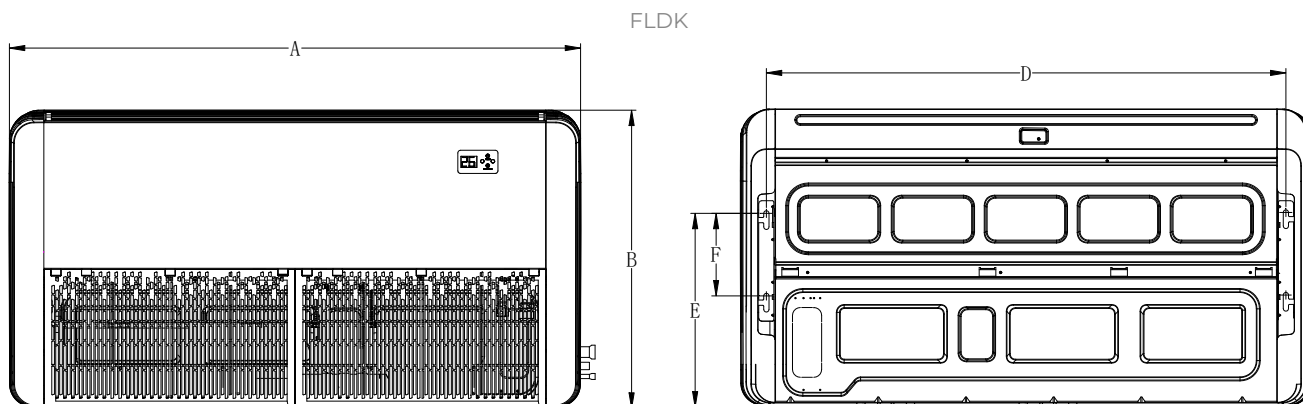

DIMENSIONS (mm)

A	B	C	D	E	F
1050	675	235	933	440	188

YDAX 035H

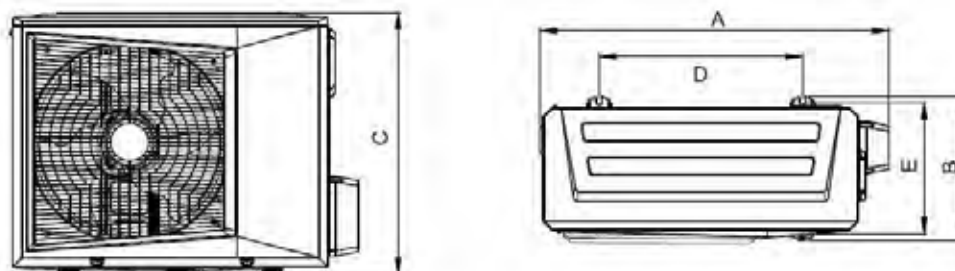

DIMENSIONS (mm)

MODEL	A	B	C	D	E
050N	880	345	555	508	314
070N	935	382	702	544	353

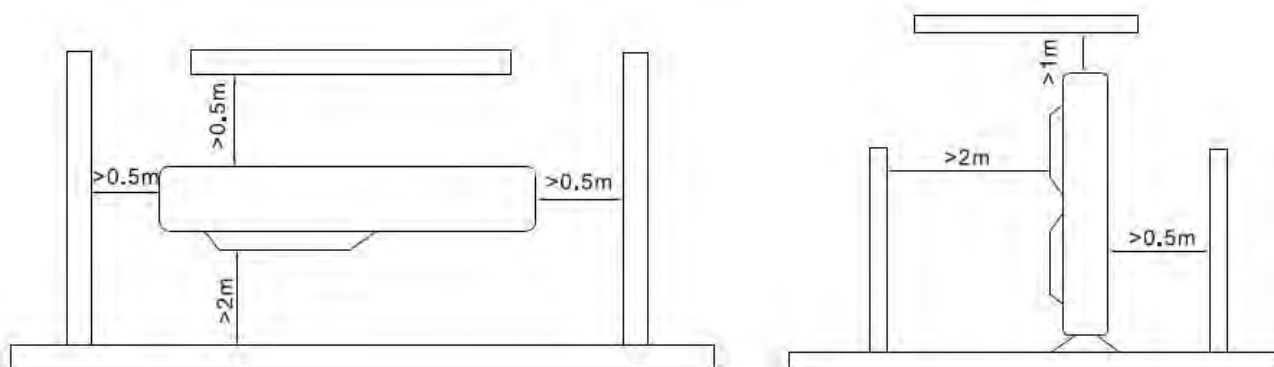

SDMX - Floor standing

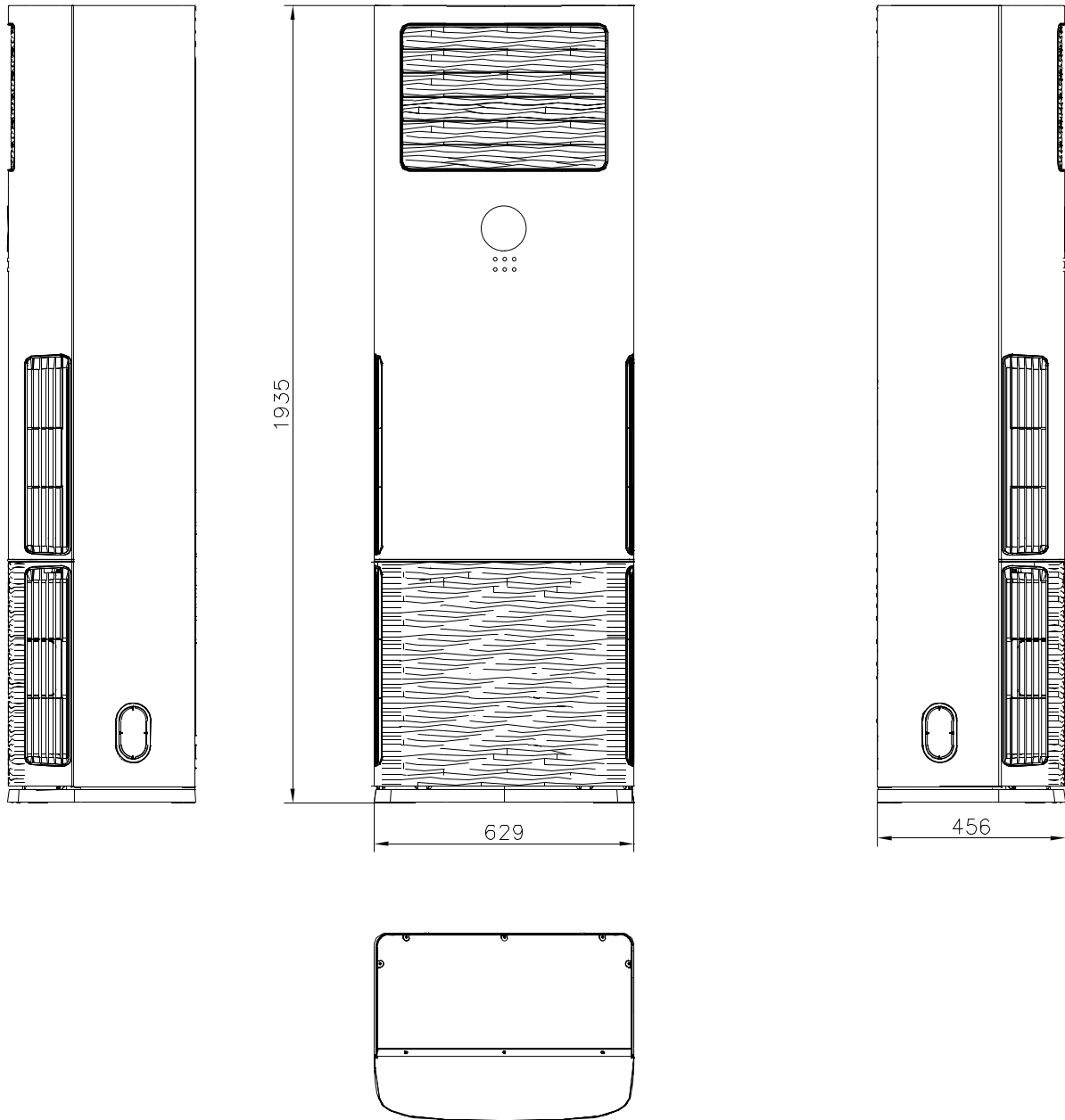

DDMX - Medium-pressure ducted

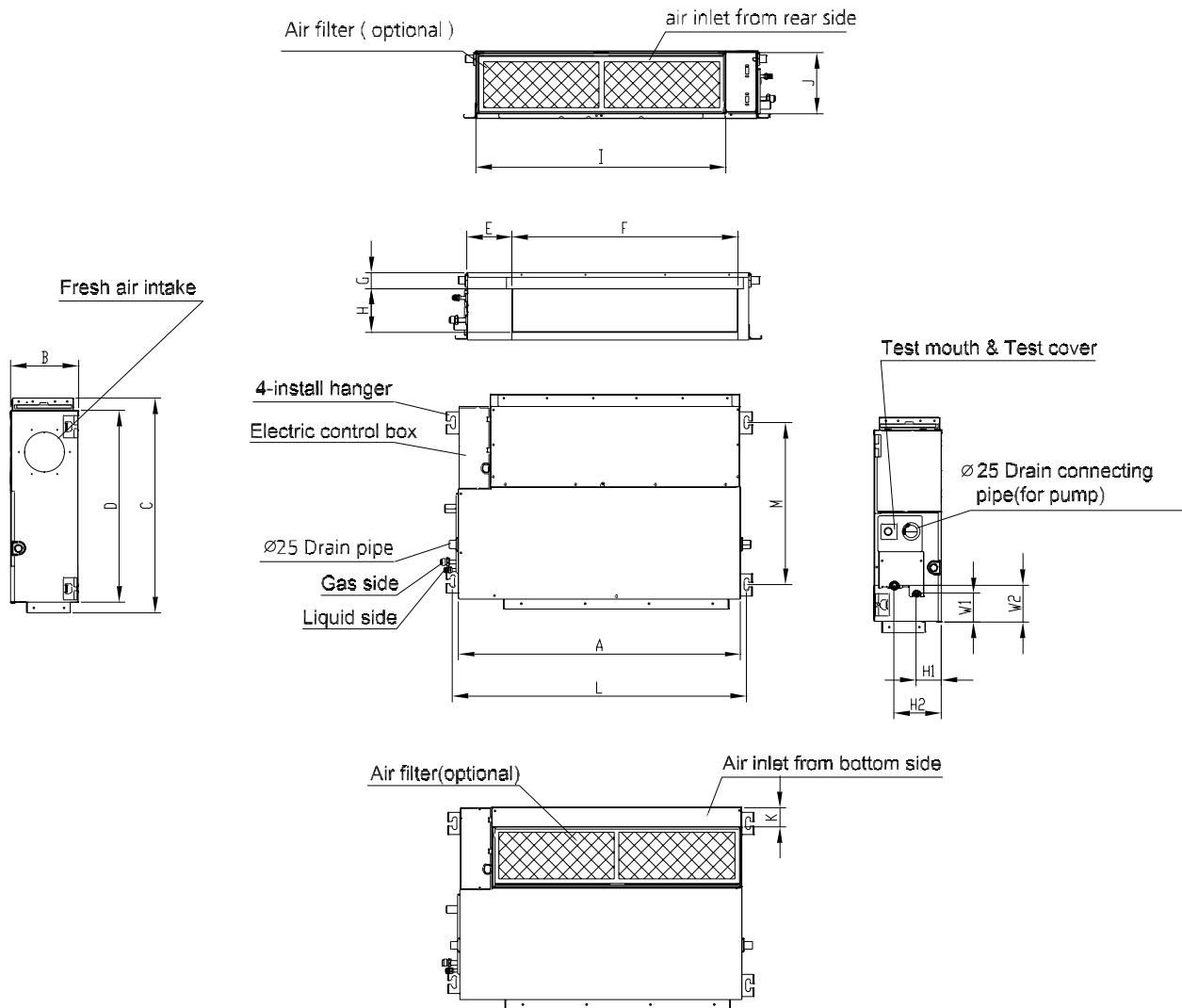

DIMENSIONS (mm)

MODEL	A	B	C	D	E	F	G	H	I	J	K	L	M	H1	H2	W1	W2
035N	700	200	506	450	137	537	30	152	599	186	50	741	360	84	140	84	84
050N	880	210	674	600	140	706	50	136	782	190	40	920	508	78	148	88	112
070N	1100	249	774	700	140	926	50	175	1001	228	5	1140	598	80	150	130	155
100N	1360	249	774	700	140	1186	50	175	1261	228	5	1400	598	80	150	130	155
140N-175N	1200	300	874	800	123	1044	50	227	1101	280	5	1240	697	80	150	185	210

JDA AIRFLOW - Thermodynamic dual-flow CMV

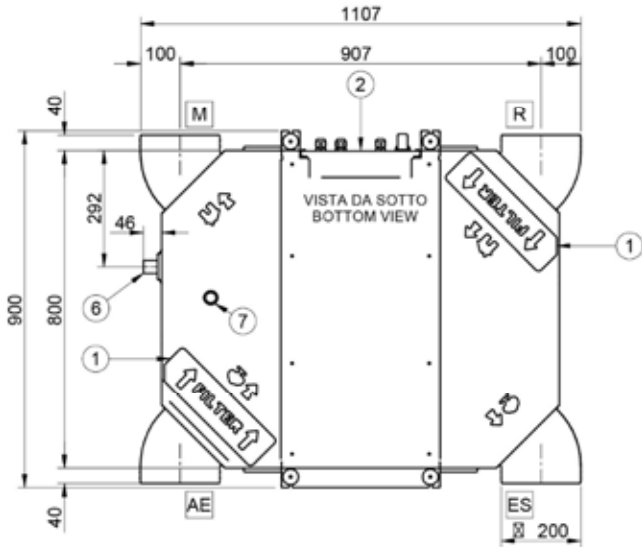
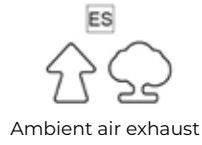

N°	DESCRIPTION
1	Removable panel for accessing the air filter
2	Electrical panel
3	Electrical connection
4	Remote control connection
5	Auxiliary connection
6	Condensate drain outlet
7	Emergency drain
W	Fastening points
AE	Fresh air intake
ES	Ambient air exhaust
M	Fresh air supply
R	Ambient air intake

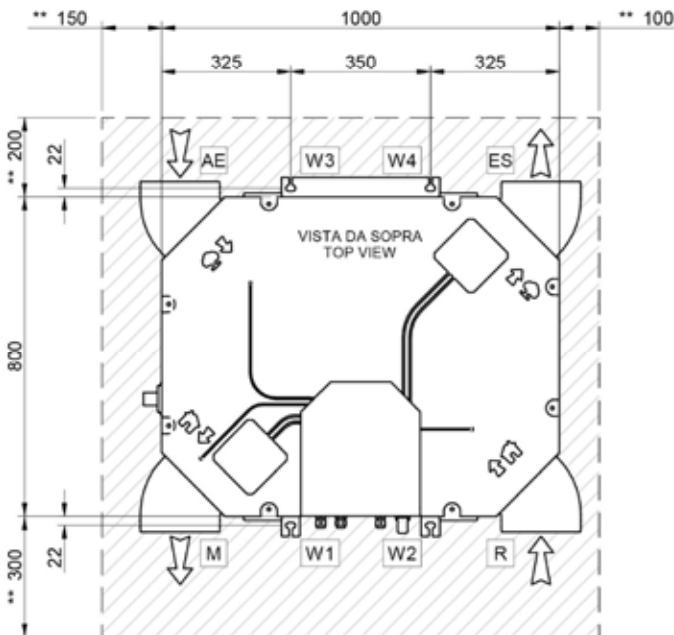
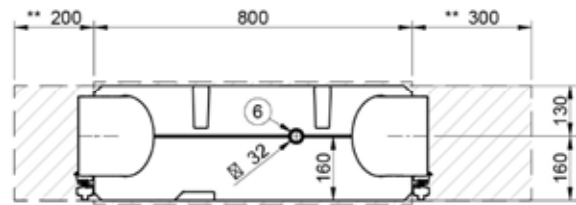
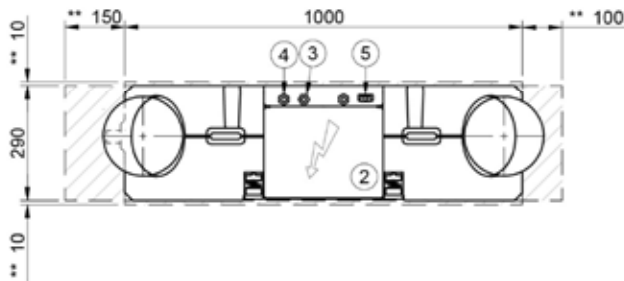

** Minimum servicing space

WEIGHT DISTRIBUTION (kg)

Unit configuration	Unit shipping weight	Weight during operation
Installation in suspended ceiling	73	44
Exposed installation	89	60

CDMX - 360° cassette

CDMX 022N-025N-035N-050N

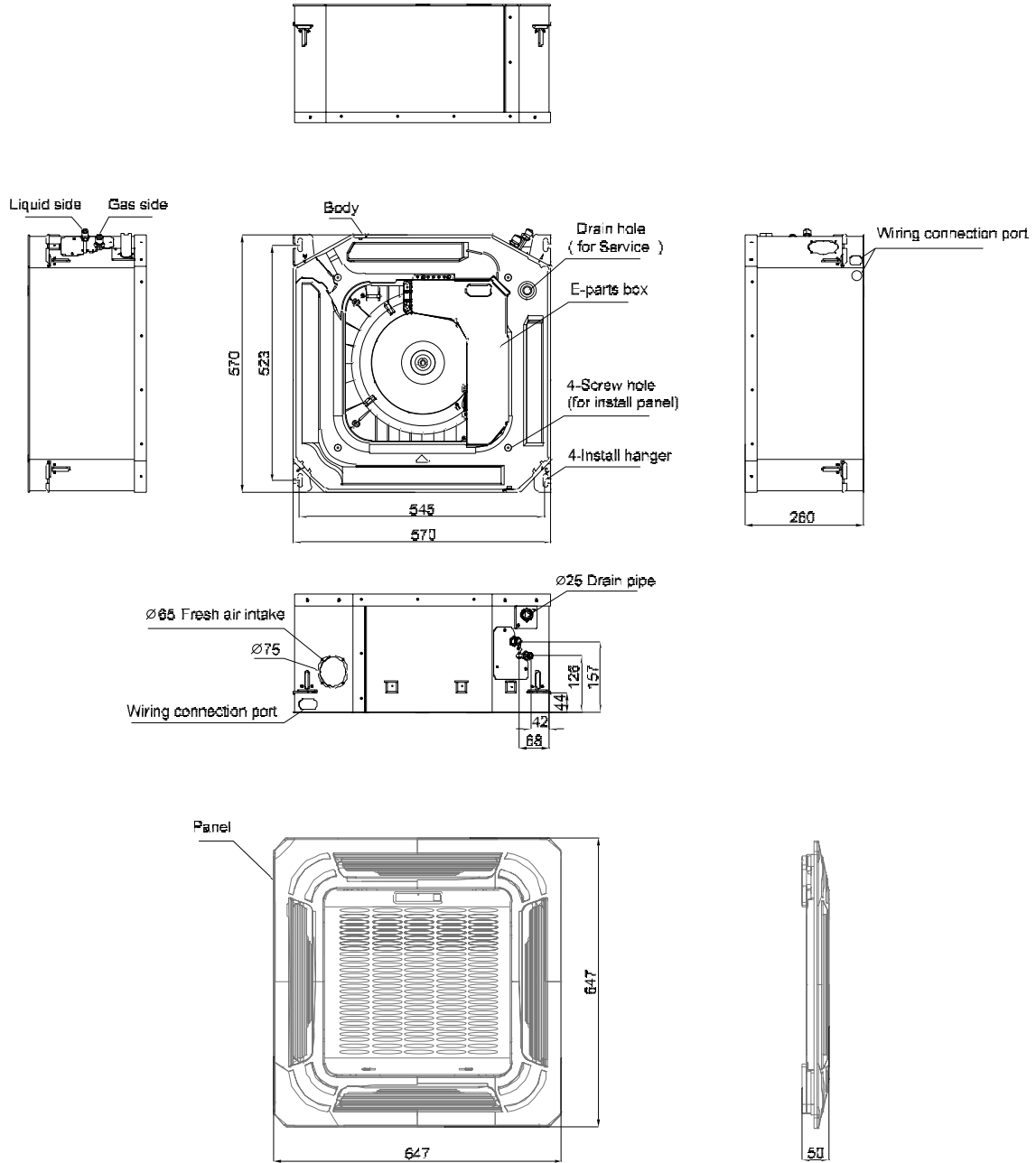

CDMX - 360° cassette

CDMX 070N-100N-140N

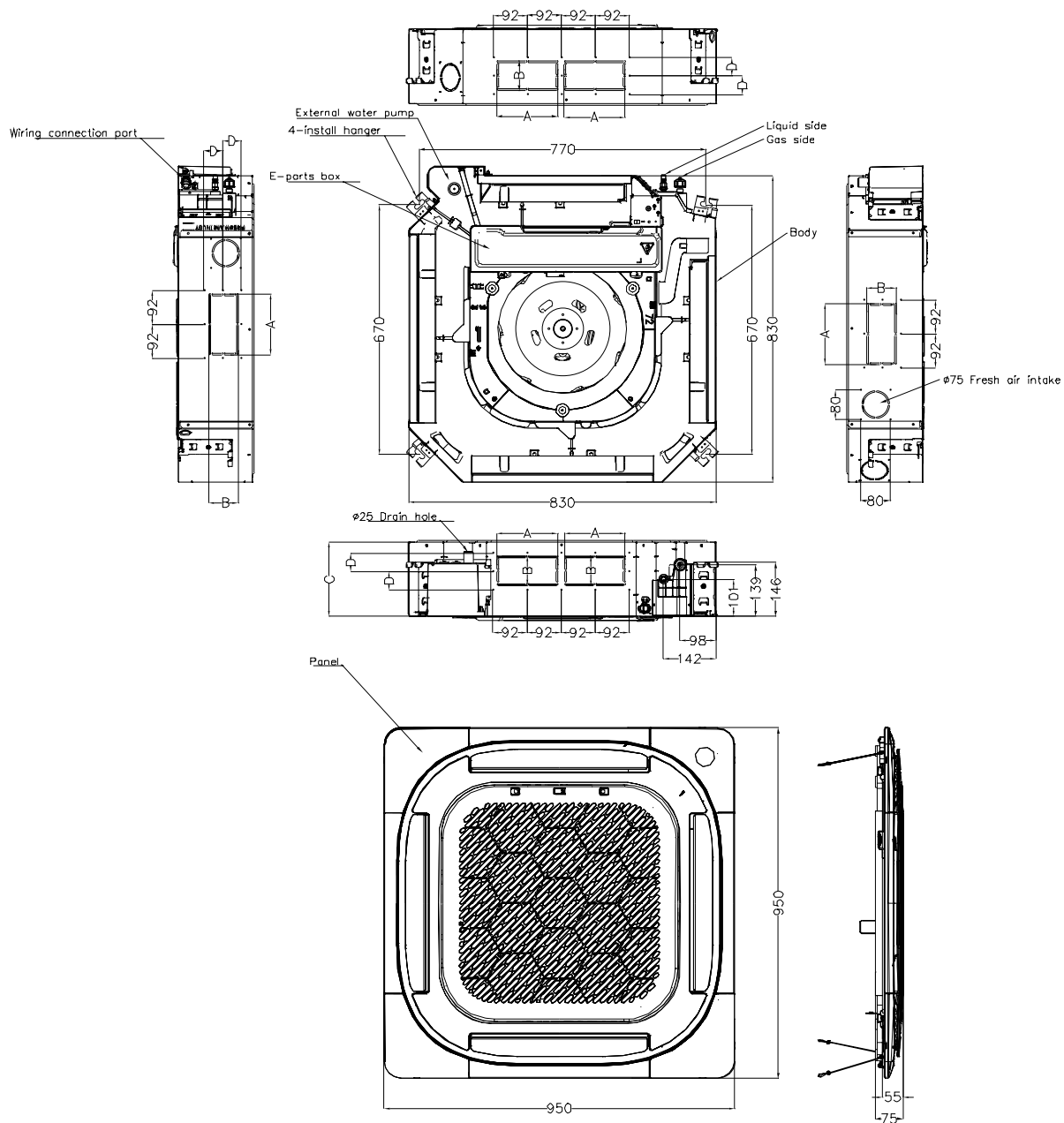

DIMENSIONS (mm)

MODEL	A	B	C	D
070N	165	80	205	50
100N	165	100	245	60
140N	165	100	287	60

YDAX - Outdoor units

YDAX 035H

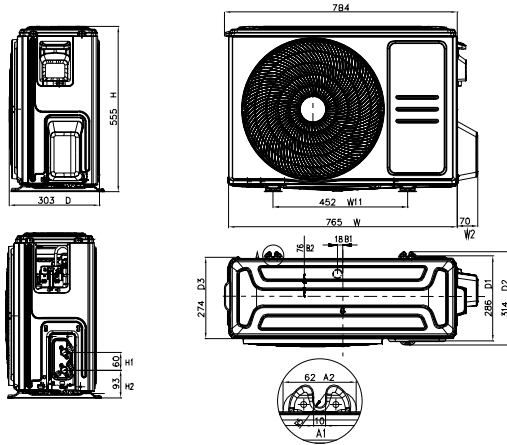

YDAX 050H

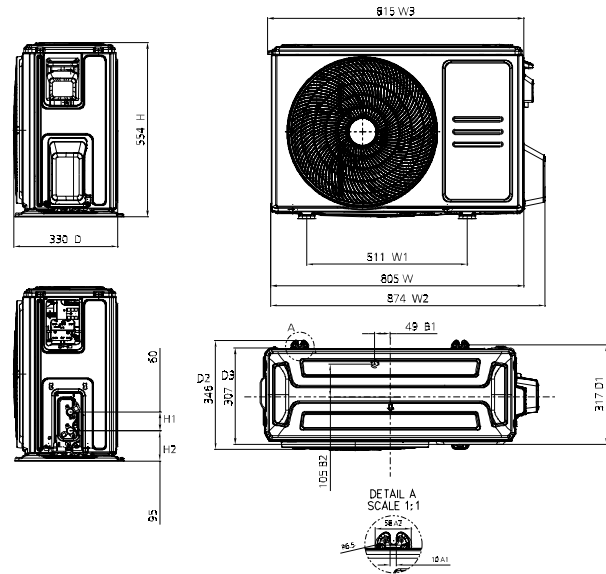

YDAX 070H

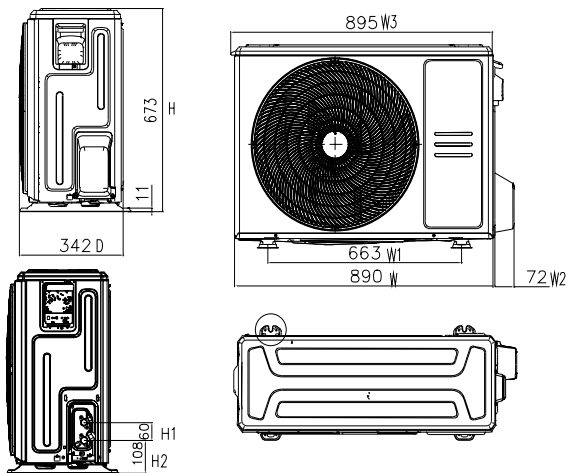

YDAX 100H

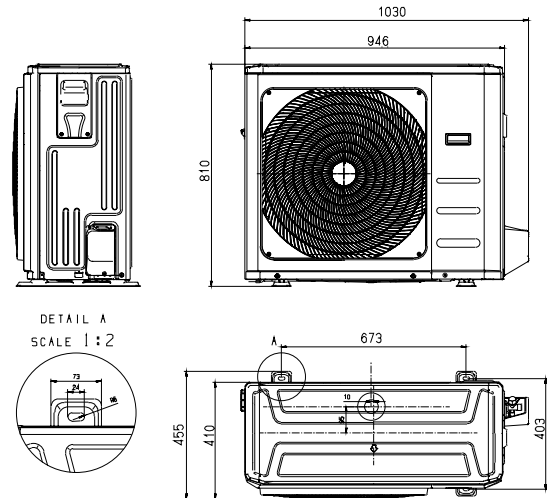

YDAX 140H

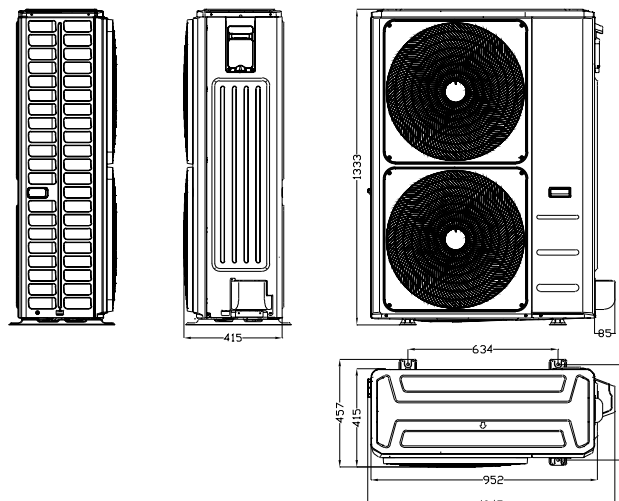

XDAW - Monoblock console

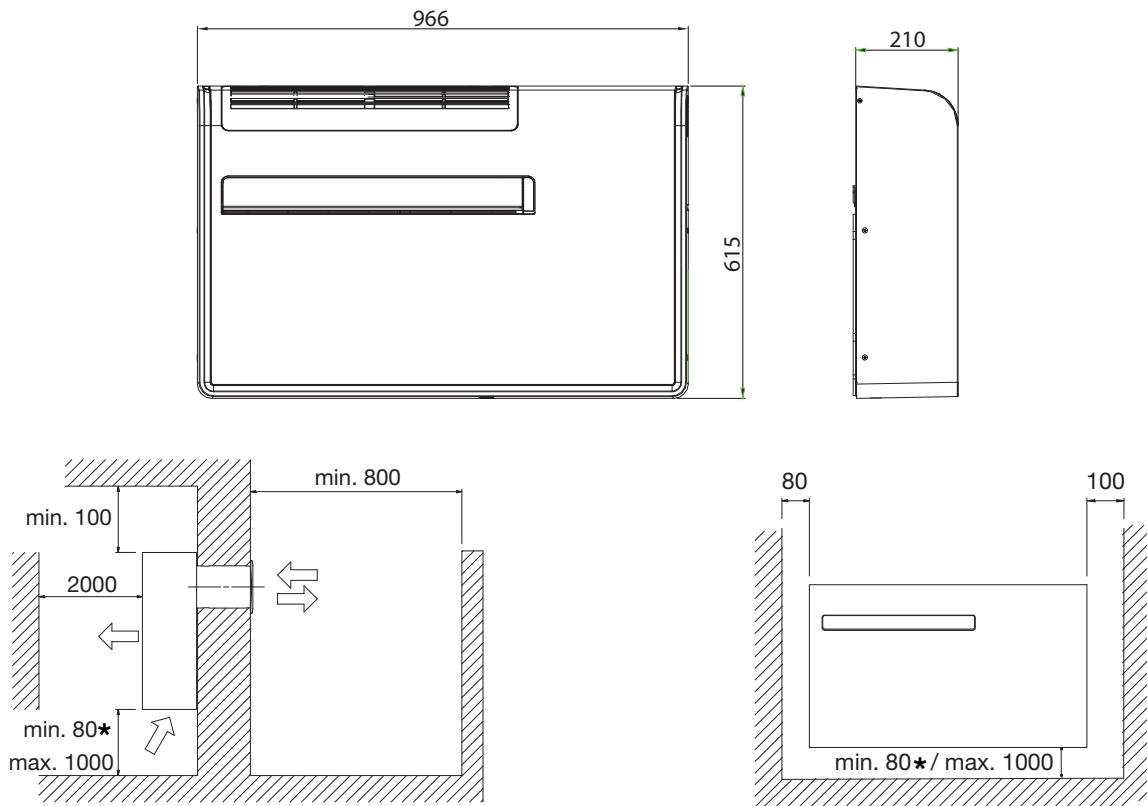

* Warning! To facilitate the condensate drain from the service cap, however, it is advisable to install the unit at a minimum height of 300 mm.

WFAE - Window

WFAE 025C

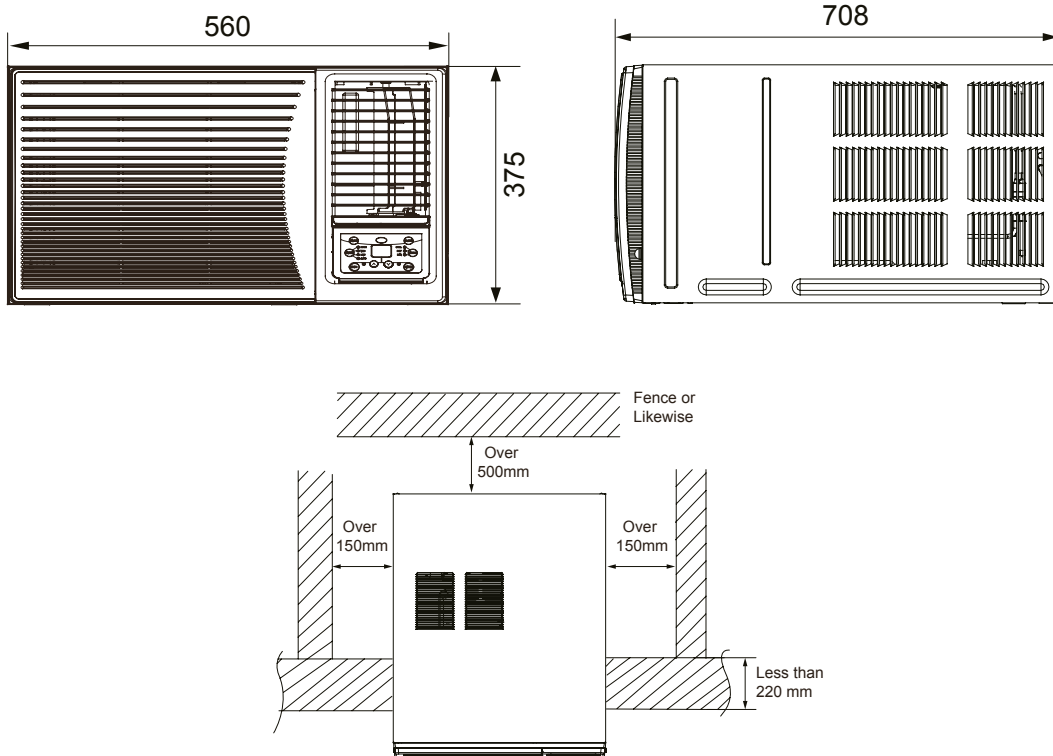

WFAE 035C

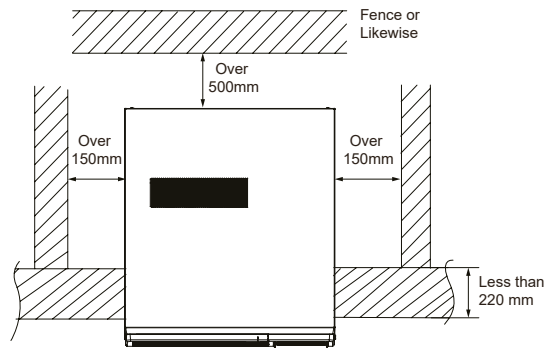
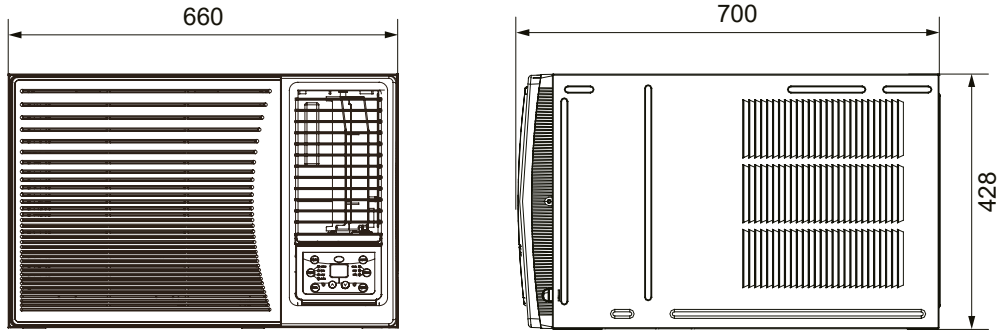

Note: There must be no barriers within 1m in front of it.

MFH - Portable

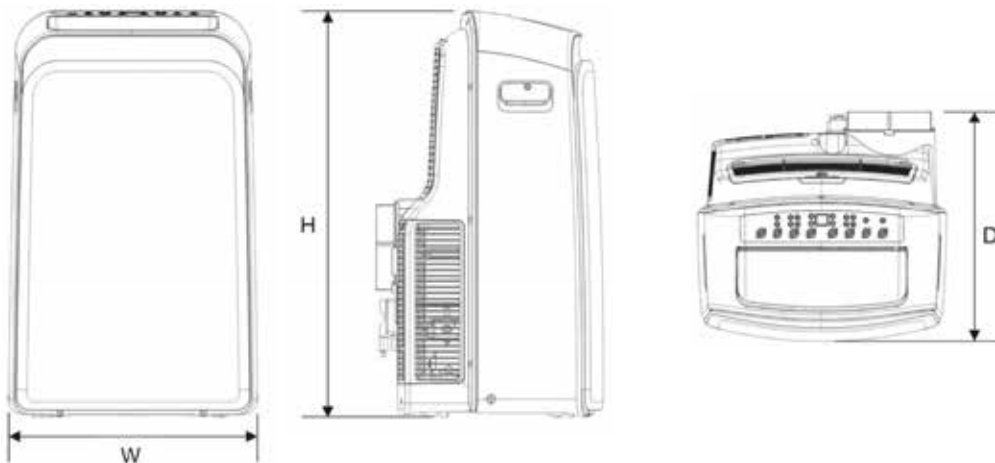

WEIGHT (kg) ET DIMENSIONS (mm)

MODEL	Weight	W	H	D
MFH010	31.8	467	765	397
MFH012	33	467	765	397

XDOW - Water-cooled console

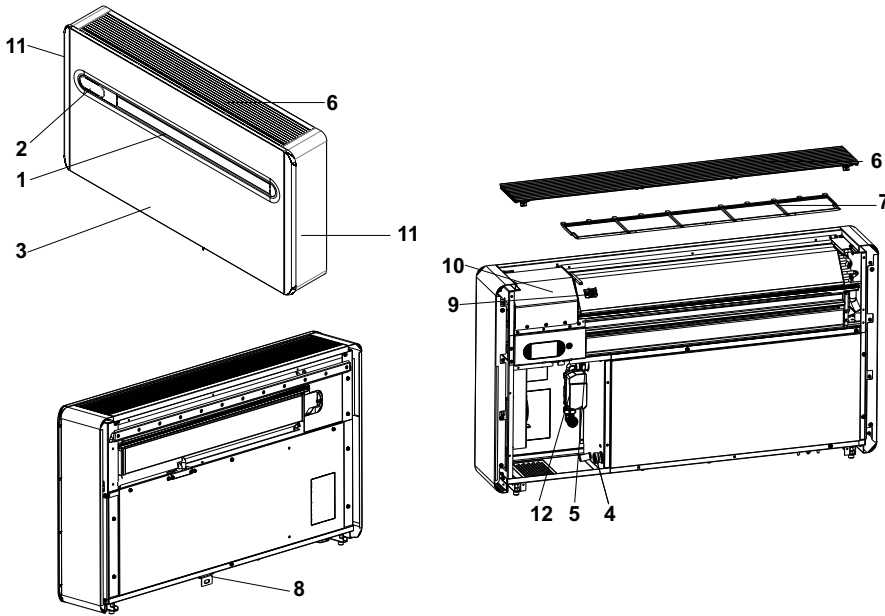

N°	DESCRIPTION
1	• Ventilation flap
2	• Control touchscreen
3	• Front panel
4	• Water inlet (Eurokonus M 3/4")
5	• Water outlet (Eurokonus M 3/4")
6	• Air intake grille
7	• Air filter
8	• Anti-uplift fastening
9	• Ambient temperature sensor
10	• Switch box
11	• Side panel
12	• Modulating valve (water side)

DFMO 22 TO 41 - Water-loop heat pump

N°	DESCRIPTION
1	• Standard unit water inlet (female)
2	• Standard unit water outlet (female)
3	• Air filter
4	• Condensate drain Ø 15 mm
5	• Electrical panel
6	• Power input
7	• Fan
8	• Compressor
9	• Direct expansion exchanger
10	• Plate exchanger
11	• Functional spaces
12	• Filter extraction (provide for the space to access the filter)
13	• Airflow
14	• Fixing brackets

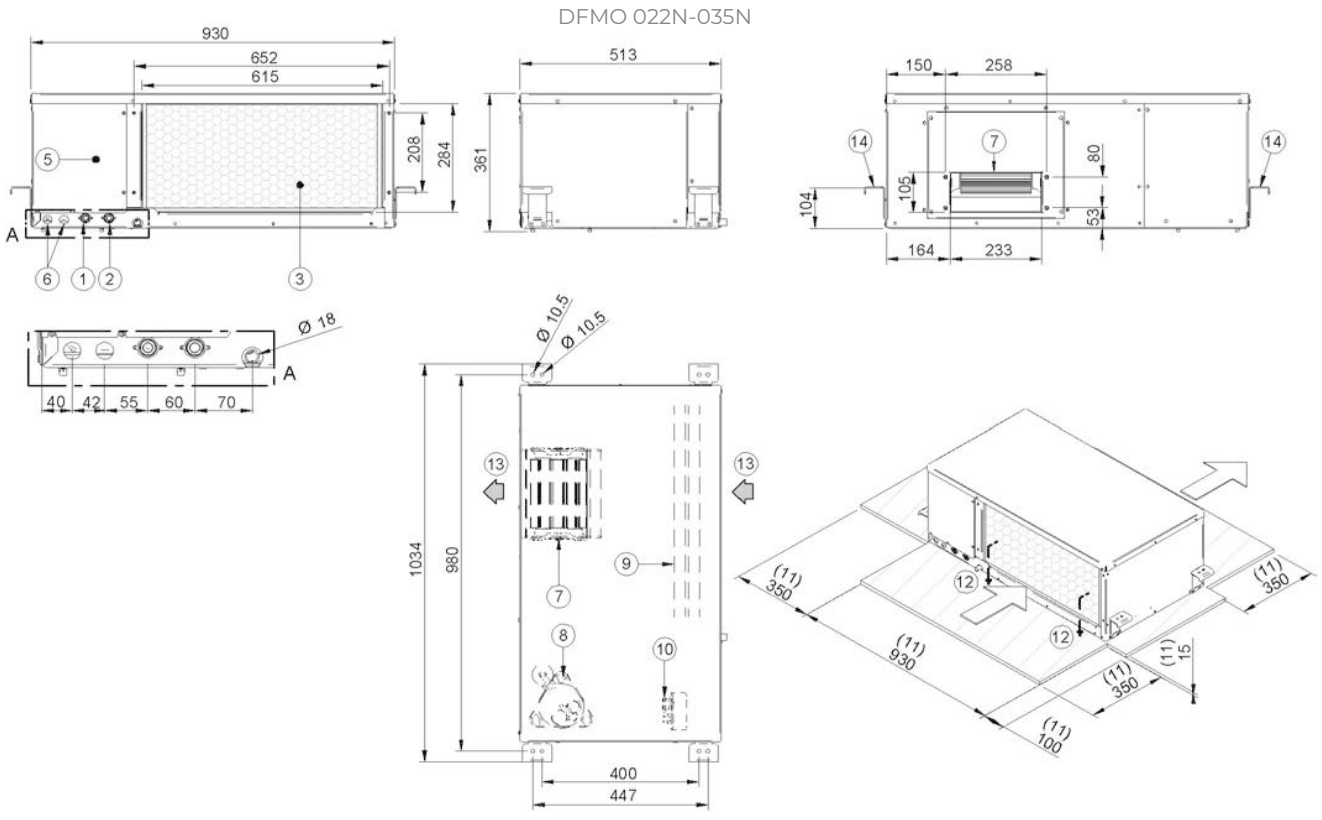

DFMO 22 TO 41 - Water-loop heat pump (continued)

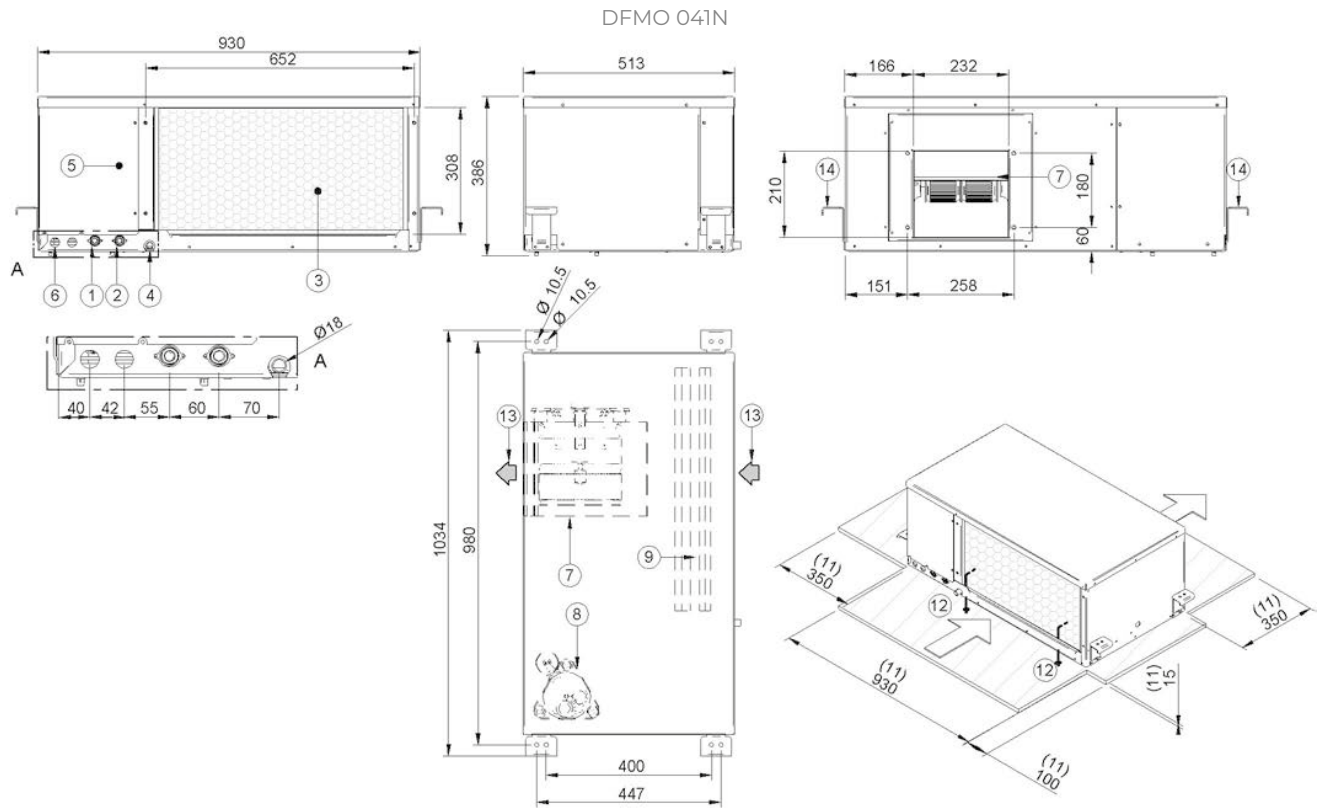

TECHNICAL DATA

MODEL		DFMO-022N-01M25	DFMO-031N-01M25	DFMO-041N-01M25
A (Length)	mm	1034	1034	1034
B (Height)	mm	361	361	386
C (Depth)	mm	513	513	513
Weight	kg	71	74	82
Standard unit water fittings	inches	1/2"	1/2"	1/2"

DFMO 45 TO 250 - Water-loop heat pump

N°	DESCRIPTION
1	• Compressor enclosure
2	• Electrical panel
3	• Power input
4	• Condensate drain
5	• Functional spaces
6	• Treatment coil
7	• Plate exchanger
8	• Plate exchanger water input 1"
9	• Plate exchanger water output 1"
10	• Air filters
11	• Electric fan (supply-return)
12	• Lifting bracket
13	• Coil - electric fan inspection
14	• Filters inspection
15	• 15 Hidraulic circuit valve connection
R	• Air inlet
MF	• Front air supply
ML	• Lateral air supply
**	• Minimun suggested clearance

DFMO 045N-080N

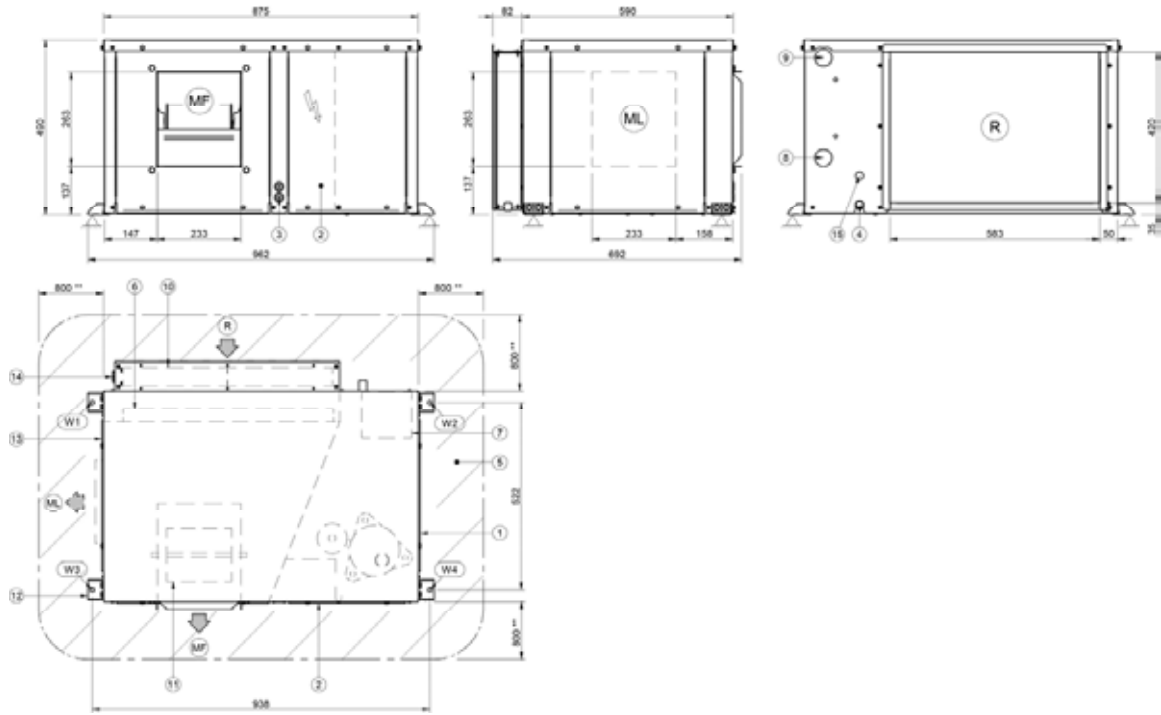

DFMO 100N-170N

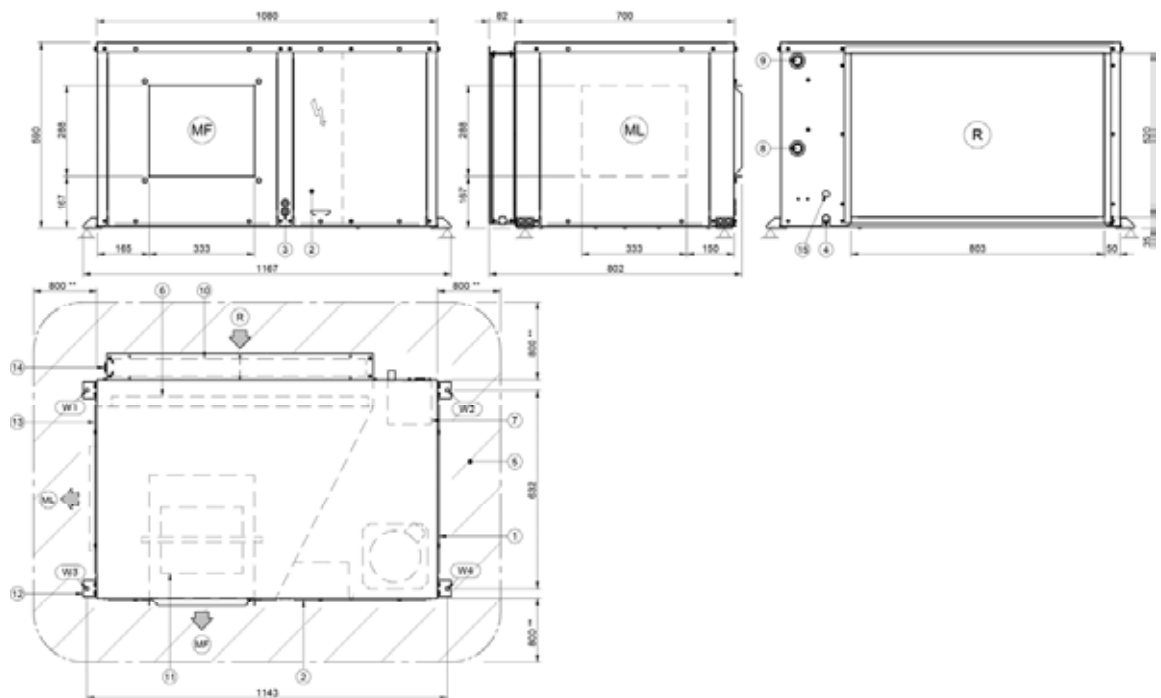

DFMO 45 TO 250 - Water-loop heat pump (continued)

DFMO 250N

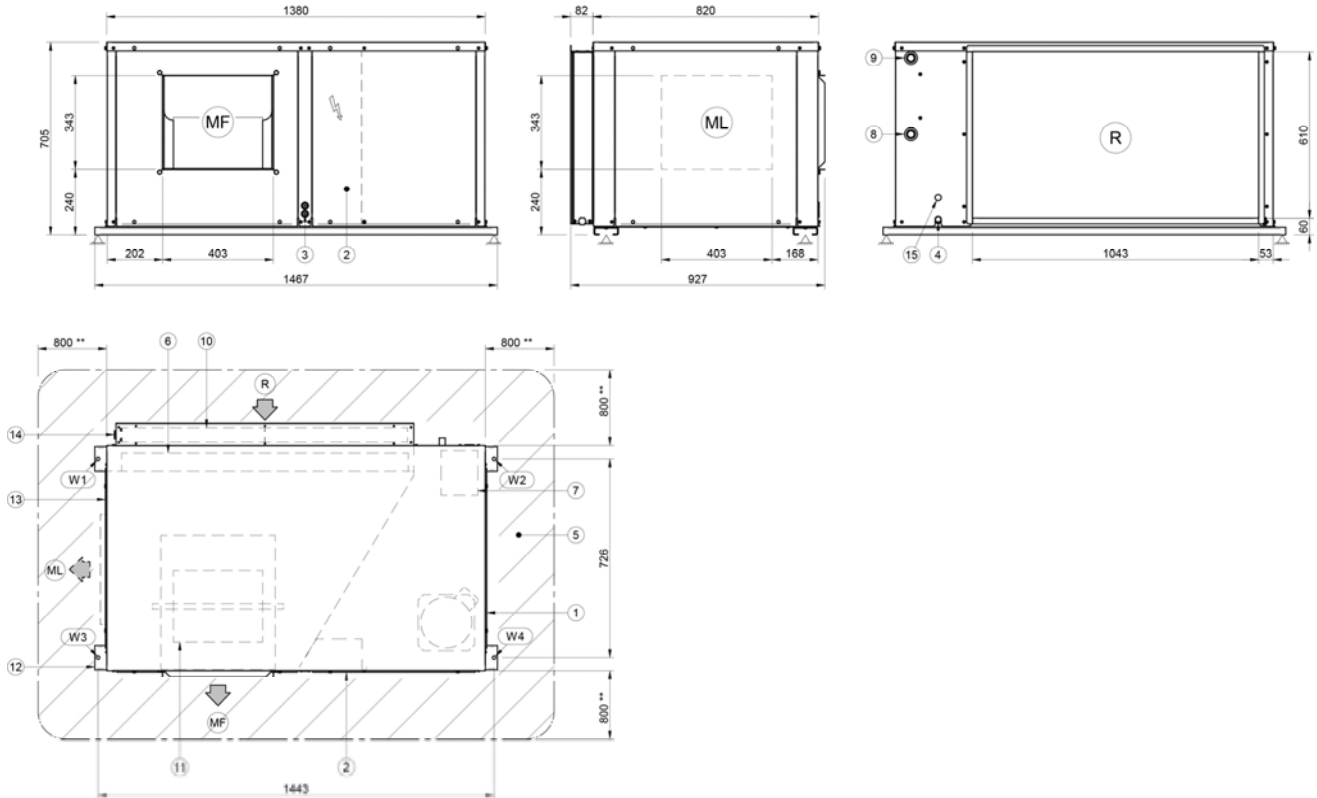

TECHNICAL DATA

MODEL		DFMO-045N-01M25	DFMO-080N-01M25	DFMO-100N-01M25	DFMO-170N-01T35	DFMO-250N-01M25
Lenght	mm	962	962	1167	1167	1467
Height	mm	490	490	590	590	705
Depth	mm	692	692	802	802	927
Operation weight	kg	98	103	138	151	200
Shipping weight	kg	102	107	143	156	225

WEIGHT DISTRIBUTION

W1 Support point	kg	22	24	31	34	37
W2 Support point	kg	25	25	36	39	54
W3 Support point	kg	24	26	33	36	52
W4 Support point	kg	27	28	38	42	57

ACCESSORY	REFERENCE	PICTURE	PART NUMBER	FUNCTION
COPPER				
INSULATED COPPER M1	1/4"-3/8" - 10ml		7ACFH0810	<ul style="list-style-type: none"> Refrigerant tubing to connect outdoor unit with indoor unit (monosplit and multisplit).
	1/4"-1/2" - 10ml		7ACFH0811	
	3/8"-5/8" - 10ml		7ACFH0812	
	1/4"-3/8" - 7ml		7ACFH0813	
	1/4"-1/2" - 7ml		7ACFH0814	
	3/8"-5/8" - 7ml		7ACFH0815	
OUTDOOR UNIT BRACKETS				
WALL BRACKET	Max. load 160 kg Horiz. 560 mm Vert. 365 mm Barre 800 mm		7ACTL0506	<ul style="list-style-type: none"> Bracket for outdoor unit installation (monosplit and multisplit).
ANTI-CORROSIONWALL BRACKET	Max. load 160 kg Horiz. 460 mm Vert. 410 mm Barre 790 mm		7ACTL0507	<ul style="list-style-type: none"> Bracket for outdoor unit installation (monosplit and multisplit).
4 ANTI-VIBRATION PADS (KIT)			7ACTL0508	<ul style="list-style-type: none"> Ideal for limiting noise and vibrations (good neighborhood).
FLOOR MOUNT RECYCLED RUBBER (PAIR)	Length 600 mm		7ACTL0509	<ul style="list-style-type: none"> Necessary for a professional installation. High quality: using rubber.
	Length 1000 mm		7ACTL0510	
FLOOR MOUNT (PAIR)	450x100 mm		7ACTL0513	<ul style="list-style-type: none"> Necessary for a professional installation. Good quality price ratio: using PVC.
CONDENSATE PUMP				
CONDENSATE PUMP MINI FLOWATCH MF2			7ACTL0517	<ul style="list-style-type: none"> Evacuates condensates from indoor units.
CONDENSATE PUMP FLOWATCHDESIGN			7ACTL0518	<ul style="list-style-type: none"> Evacuates condensates from indoor units.



Regulations ON R410A FLUID CONCENTRATION

CALCULATION EXAMPLE

Classic case of a hotel, i.e. a category "A" building.

THE PROJECT/EXAMPLE CHARACTERISTICS ARE:

- ▶ Typical 2-3* hotel.
- ▶ VRF system designed to supply 12 to 16 rooms.
- ▶ Outdoor unit model 280 (10 HP).
- ▶ Reversible VRF that can supply up to 16 units.
- ▶ 11 kg of R410A refrigerant recommended.
- ▶ Smaller bedroom, bathroom included:
13 m² > volume = 32.50 m³.
- ▶ CMV ventilation of 60 m³/h, i.e. 10 m³ in 10 minutes.

THIS GIVES THE FOLLOWING CALCULATION:

- ▶ Room volume to take into account:
32.50 + 10 = 42.50 m³.
- ▶ **MAXIMUM LOAD UNDER THE STANDARD:**
0.44 kg/m³ x 42.5 m³ = 18.7 kg of refrigerant
- ▶ Since the calculation is determined for the room with the smallest volume, the total refrigerant capacity of the installation must be taken into account:
 - Outdoor unit (11 kg) + network backup.
 - The network back-up is calculated according to the lengths and diameters of the copper piping used. See refrigeration diagram.
- ▶ **MAXIMUM PROJECT LOAD CALCULATION:**
11 kg + (4.520 kg) = 15.520 kg of refrigerant

COMPLIANT WITH REGULATIONS

LENGTH			
1 inch (in)	0.0254 m		
1 foot (ft)	12 inches	0.3048 m	
1 yard (yd)	3 feet	0.9143 m	
1 mile (mi)	1.760 yards	1609 m	
1 nautical mile (nmi)	1852 m		
1 meter (m)	39.37 inches	3.28084 feet	1.09361 yard

MM	INCHES
6.35	1/4
9.52	3/8
12.70	1/2
15.88	5/8
19.05	3/4
22.22	7/8
25.40	1
28.58	1 1/8
31.75	1 1/4
38.10	1 1/2

VOLUME	
1 cubic inch (cu in)	16.387064 cm ³
1 cubic foot (cu ft)	0.028317 m ³ /28.31685 dm ³
1 cubic yard (cu yd)	0.76455 m ³
1 pint	0.568 l
1 gallon-imp	4.546 l
1 gallon (US gal)	3.78541 l or dm ³
1 cubic meter (m ³)	35.31467 cu ft
1 cubic decimeter (dm ³)	0.26428 gal
1 liter (l)	1 dm ³

HP (HORSE POWER) *	BTU	KW
1	9000	2.637
1.5	12000	3.516
2	18000	5.274
2.5	24000	7.032
3	30000	8.79
5	45000	13.185

MASS VOLUME	
1 cu.ft/lb	62.43 dm ³ /kg
1 US gallon/pound	8.3 dm ³ /kg

DENSITY	
1 pound/cu.ft	0.016 kg/dm ³

MASS		
1 ounce (oz)	28.349 g	
1 pound (lb)	16 oz	0.4536 kg
1 quintal U.S	100 lbs	
1 centweight	112 lbs	
1 short ton (US)	2000 lbs	907.18 kg
1 long ton (GB)	2240 lbs	1016.04 kg
1 quintal (q)	100 kg	
1 tonne (t)	1000 kg	

AREA		
1 square inch (in ²)	6.4516 cm ²	
1 square foot (ft ²)	0.0929 m ²	
1 square yard (yd ²)	0.8361 m ²	
1 square meter (m ²)	1550 in ²	10.76391 ft ²

ENERGY - HEAT QUANTITY		
1 cal	4.18 joules	
1 Btu	0.252 kcal	1055 joules
1 Btu/lb.°F	1 kcal/kg °C	
1 kcal	1 millithermie	
1 fg/h	-1 kcal/h	
1 kcal/h	1.163 W	
1 Btu/h	0.293 W	
1 ton (US)	3024 kcal/h	3512 W
1 ton (GB)	3340 kcal/h	3878 W
1 watt (thermic)	0.86 kcal/h	

° Fahrenheit = °C x 9/5 + 32 / ° Celsius = (°F-32) x 5/9 / ° Celsius = T (Kelvin) - 273.15.
 * Indicative values

Rated capacities of our products are given for air conditions as following:
 Cooling mode: 35°C out/27°C in (Dry bulb)
 Heating mode: +7°C out/20°C in (Dry bulb)

NEW PRODUCT

naming system

Discover below some tips to decipher our references and product codes more quickly.

1 ► UNDERSTANDING PRODUCT CODES

DIGIT N° 1	DIGIT N° 2 & 3 Product constitution	DIGIT N° 4 & 5 subfamily
2 AirSolar	VF VRF	01 Floor ceiling
7 Airwell	OG Chilled water terminal	02 High wall
E Electra	KT Kit	03 Ducted
J Johnson	MB Monoblock	04 Cassette
	SP Split (2 units)	05 Window
	CK Unassembled product	06 Monosplit condensing unit
	PR Spare part	07 Console
	EN Renewable energy	08 Portable
		09 Multisplit condensing unit
		10 Floor standing
		11 Airflow
		12 Rooftop unit
		13 Hydraulic module
		17 Thermodynamic water heater
		18 Vertical cabinet
		14 Monoblock condensing unit
		15 VRF water source
		19 Water source
		20 Water condenser
		21 Water-cooled condensing unit
		22 Hybrid panel
		23 Photovoltaic panel
		24 Heating panel
		25 Micro-inverter

2 ► UNDERSTANDING ACCESSORY CODES

DIGIT N° 1	DIGIT N° 2 & 3	DIGIT N° 4 & 5 (& 6)
7 Airwell assembled product	AC Accessories	EL Electricity kit - Heating
		ELH Electricity kit - Heating / VRF
		FH Cold & hydraulic kit
		FHH Cold & hydraulic kit / VRF
		TL Sheeting Kit / Casing & Metal sheet Kit
		VF Fan & airflow kit
		VFH Fan & airflow / VRF kit

3 ► UNDERSTANDING PRODUCT REFERENCES

See the table below to help you understand the new product naming system.

TYPE	TECHNOLOGY	PRODUCT POSITIONING / IDU	UPGRADE	SIZE (kW)	MODE	REFRIGERANT	PHASE (current type)	POWER SUPPLY	ELECTRICAL FREQUENCY
B Monoblock condensing unit	D DC Inverter	L Entry level	W 1 st upgrade	015 5000BTU / 1,5 kW	N Neutral	01 R410A	M Single-phase	1 110 V	5 50 Hz
C Cassette	F Fix RPM	M Medium level	X 2 nd upgrade	022 7000BTU / 2,2 kW	T Triple-service	02 R407C	T Three-phase	2 220-230 V	6 60 Hz
D Ducted	V VRF	H High-end	Y 3 rd upgrade	025 9000BTU / 2,5 kW	C Cooling only	03 R134A		3 380-400 V	2 50Hz/60Hz
F Floor ceiling	N Neutral	VEHICLE OF EXCHANGE / ODU	Z 4 th upgrade	035 12000BTU / 3,5 kW	R Reversible	04 R290		4 460 V	
H High wall		A Air / Air		050 18000BTU / 5 kW	H Heating only	05 CO ₂			
J Ventilation		H Air / Water		060 21000BTU / 6 kW	M Monocrystalline	06 R22			
M Portable		W Water / Water		070 24000BTU / 7 kW	P Polycrystalline	07 R410a + R32			
O Hydraulic module		O Water / Air		080 27000BTU / 8 kW		08 H ₂ O			
P Vertical cabinet				090 30000BTU / 9 kW		09 R32			
R Rooftop				100 36000BTU / 10 kW		10 Solar			
S Floor standing				120 42000BTU / 12 kW					
T Thermodynamic water heater				140 48000BTU / 14 kW					
V Condensing unit VRF				150 50000BTU / 15 kW					
W Window				160 55000BTU / 16 kW					
X Console				170 58000BTU / 17 kW					
Y Monosplit condensing unit				300 30 kW					
Z Multisplit condensing unit				...					

4 ► UNDERSTANDING SERIAL NUMBERS

Each unit (IDU or ODU) is also identify with a unique serial number which can assist tracing the unit.

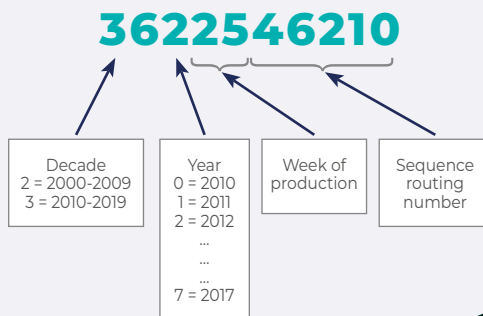

Equivalences

OLD DESIGNATION	OLD PART NUMBER	NEW DESIGNATION	NEW PART NUMBER
HDH High wall range		HDMB High wall range	
AW-HDH009-N91	7SP023186	HDMB-025N-09M22	7SP023235
AW-HDH012-N91	7SP023187	HDMB-035N-09M22	7SP023236
AW-HDH018-N91	7SP023188	HDMB-050N-09M22	7SP023237
AW-HDH024-N91	7SP023189	HDMB-070N-09M22	7SP023238
-	-	HDMB-025N-09M22-MR	7SP23240
AW-HDH012-N91-B	7SP023216	HDMB-035N-09M22-MR	7SP023241
AW-HDH018-N91-B	7SP023217	HDMB-050N-09M22-MR	7SP023242
AW-HDH024-N91-B	7SP023218	HDMB-070N-09M22-MR	7SP023243
AW-HDH009-N91-G	7SP023211	HDMB-025N-09M22-GY	7SP023244
AW-HDH012-N91-G	7SP023212	HDMB-035N-09M22-GY	7SP023245
AW-HDH018-N91-G	7SP023213	HDMB-050N-09M22-GY	7SP023246
AW-HDH024-N91-G	7SP023214	HDMB-070N-09M22-GY	7SP023247
AW-YHDHA09-H91	7SP063150	YDAB-025H-09M22	7SP063155
AW-YHDHA12-H91	7SP063151	YDAB-035H-09M22	7SP063156
AW-YHDH018-H91	7SP063037	YDAB-050H-09M22	7SP063157
AW-YHDH024-H91	7SP063038	YDAB-070H-09M22	7SP063158
HDLW High wall range		HDLE High wall range	
AW-HDLW007-N91	7SP023200	HDLE-022N-09M25	7SP023270
AW-HDLW009-N91	7SP023201	HDLE-025N-09M25	7SP023271
AW-HDLW012-N91	7SP023202	HDLE-035N-09M25	7SP023272
AW-HDLW018-N91	7SP023203	HDLE-050N-09M25	7SP023273
AW-HDLW024-N91	7SP023204	HDLE-070N-09M25	7SP023274
-	-	YDAE-022R-09M25	7SP063200
AW-YHDL009-H91	7SP062960	YDAE-025R-09M25	7SP063201
AW-YHDL012-H91	7SP062961	YDAE-035R-09M25	7SP063202
AW-YHDL018-H91	7SP062962	YDAE-050R-09M25	7SP063203
AW-YHDL024-H91	7SP062963	YDAE-070R-09M25	7SP063204
XDL Console range		XDLF Console range	
AW-XDL009X-N91	7SP071424	XDLF-025N-09M25	7SP071440
AW-XDL012-N91	7SP071425	XDLF-035N-09M25	7SP071441
AW-XDL018-N91	7SP071426	XDLF-050N-09M25	7SP071442
AW-YXDL012-H91	7SP063101	YDAF-035R-09M25	7SP063205
AW-YXDL018-H91	7SP063102	YDAF-050R-09M25	7SP063206
FWDB Floor ceiling range		FDLK Floor ceiling range	
AW-FWDB018-N91	7SP012290	FDLK-050N-09M25	7SP012315
AW-FWDB024-N91	7SP012291	FDLK-070N-09M25	7SP012316
AW-YMDB018-H91	7SP063114	YDAK-050R-09M25	7SP063195
AW-YMDB024-H91	7SP063115	YDAK-070R-09M25	7SP063196

Equivalences

OLD DESIGNATION	OLD PART NUMBER	NEW DESIGNATION	NEW PART NUMBER
HKD R32 High wall range		HDLA High wall range	
AW-HKD009-N91	7SP023135	HDLA-025N-09M25	7SP023250
AW-HKD012-N91	7SP023136	HDLA-035N-09M25	7SP023251
AW-HKD018-N91	7SP023137	HDLA-050N-09M25	7SP023252
AW-HKD024-N91	7SP023138	HDLA-070N-09M25	7SP023253
AW-YKD009-H91	7SP063040	YDAA-025H-09M25	7SP063160
AW-YKD012-H91	7SP063041	YDAA-035H-09M25	7SP063161
AW-YKD018-H91	7SP063042	YDAA-050H-09M25	7SP063162
AW-YKD024-H91	7SP063043	YDAA-070H-09M25	7SP063163
YDZC Multisplit range		ZDAA Multisplit range	
AW-YDZC218-H91	7SP091191	ZDAA-2050-09M25	7SP091195
AW-YDZC327-H91	7SP091192	ZDAA-3080-09M25	7SP091196
AW-YDZC436-H91	7SP091183	ZDAA-4090-09M25	7SP091197
AW-YDZC542-H91	7SP091184	ZDAA-5130-09M25	7SP091198
YDZB Multisplit range		ZDAE Multisplit range	
-	-	ZDAE-2040-09M25	7SP091200
AW-YDZB218-H91	7SP091178	ZDAE-2050-09M25	7SP091201
-	-	ZDAE-3060-09M25	7SP091202
AW-YDZB327-H91	7SP091179	ZDAE-3070-09M25	7SP091203
AW-YDZB430-H91	7SP091180	ZDAE-4080-09M25	7SP091204
AW-YDZB542-H91	7SP091190	ZDAE-5130-09M25	7SP091205
HKD R410A High wall range		HDLS High wall range	
AWSI-HKD009-N11	7SP023130	HDLS-025N-01M25	7SP023255
AWSI-HKD012-N11	7SP023131	HDLS-035N-01M25	7SP023256
AWSI-HKD018-N11	7SP023132	HDLS-050N-01M25	7SP023257
AWSI-HKD024-N11	7SP023133	HDLS-070N-01M25	7SP023258
AWAU-YKD009-H11	7SP062910	YDAS-025H-01M25	7SP063165
AWAU-YKD012-H11	7SP062911	YDAS-035H-01M25	7SP063166
AWAU-YKD018-H11	7SP062952	YDAS-050H-01M25	7SP063167
AWAU-YKD024-H11	7SP062913	YDAS-070H-01M25	7SP063168
YCZ Multisplit range		-	
AWAU-YCZ218-H11	7SP091185	-	-
AWAU-YCZ327-H11	7SP091186	-	-
AWAU-YCZ430-H11	7SP091187	-	-
AWAU-YCZ542-H11	7SP091173	-	-
DDB R410A Ducted range		DDHA Ducted range	
AW-DDB068-N11	7SP033046	DDHA-200N-01M22	7SP033090
AW-DDB085-N11	7SP033047	DDHA-250N-01M22	7SP033091
AW-DDB102-N11	7SP033048	DDHA-300N-01M22	7SP033092
AW-DDB136-N13	7SP033049	DDHA-400N-01T32	7SP033093
AW-YDDB068-H13	7SP063105	ADAA-200R-01T32	7SP260000
AW-YDDB085-H13	7SP063106	ADAA-250R-01T32	7SP260001
AW-YDDB102-H13	7SP063107	ADAA-300R-01T32	7SP260002

Equivalences

OLD DESIGNATION		OLD PART NUMBER		NEW DESIGNATION		NEW PART NUMBER	
TERTIARY R32							
CDM R32 Cassette range				CDMX R32 Cassette range			
AW-CDM009X-N91		7SP042261X		CDMX-025N-09M25		7SP042290	
AW-CDM012-N91		7SP042262		CDMX-035N-09M25		7SP042291	
AW-CDM018-N91		7SP042263		CDMX-050N-09M25		7SP042292	
AW-CDM024-N91		7SP042264		CDMX-070N-09M25		7SP042293	
AW-CDM036-N91		7SP042265		CDMX-100N-09M25		7SP042294	
AW-CDM048-N91		7SP042266		CDMX-140N-09M25		7SP042295	
Panel				-			
Panel CBD/CBF/CCD/CDM/CFM 647x647		7ACVF0566		-		7ACVF0566	
Panel CBD/CBF/CCD/CFM/CDM 950x950		7ACVF0564		-		7ACVF0600	
DDM R32 Ducted range				DDMX R32 Ducted range			
AW-DDM012-N91		7SP033031		DDMX-035N-09M25		7SP033070	
AW-DDM018-N91		7SP033032		DDMX-050N-09M25		7SP033071	
AW-DDM024-N91		7SP033033		DDMX-070N-09M25		7SP033072	
AW-DDM036-N91		7SP033034		DDMX-100N-09M25		7SP033073	
AW-DDM048-N91		7SP033035		DDMX-140N-09M25		7SP033074	
AW-DDM060-N91		7SP033036		DDMX-175N-09M25		7SP033075	
FDM R32 Floor ceiling range				FDMX R32 Floor ceiling range			
AW-FDM018-N91		7SP012263		FDMX-050N-09M25		7SP012300	
AW-FDM024-N91		7SP012264		FDMX-070N-09M25		7SP012301	
AW-FDM036-N91		7SP012265		FDMX-100N-09M25		7SP012302	
AW-FDM048-N91		7SP012266		FDMX-140N-09M25		7SP012303	
AW-FDM060-N91		7SP012267		FDMX-175N-09M25		7SP012304	
XDM R32 Console range				XDMX R32 Console range			
AW-XDM012X-N91		7SP071413X		XDMX-035N-09M25		7SP071435	
AW-XDM018-N91		7SP071414		XDMX-050N-09M25		7SP071436	
SDM R410A Floor standing range				SDMX R32 Floor standing range			
AW-SDM048-N11		7SP011088		SDMX-140N-09M35		7SP101060	
AW-YSDM048-H11		7SP062971		YDAX-140H-09T35		7SP063175	
Tertiary outdoor unit R32				Tertiary outdoor unit R32			
AW-YDFA012-H91		7SP063050		YDAX-035H-09M25		7SP063170	
AW-YDFA018-H91		7SP063051		YDAX-050H-09M25		7SP063171	
AW-YDFA024-H91		7SP063052		YDAX-070H-09M25		7SP063172	
AW-YDFA036-H91		7SP063053		YDAX-100H-09M25		7SP063173	
AW-YDFA036-H93		7SP063054		YDAX-100H-09T35		7SP063174	
AW-YDFA048-H93		7SP063055		YDAX-140H-09T35		7SP063175	
AW-YDFA060-H93		7SP063056		YDAX-175H-09T35		7SP063176	

Equivalences

OLD DESIGNATION	OLD PART NUMBER	NEW DESIGNATION	NEW PART NUMBER
XDA Console range		XDA Console range	
AW-XDA009-N91	7SP071430	No change in designation and part number	
WFD Window range		WFAE Window range	
AWWR-WFD009-C11	7WT010008	WFAE-025C-09M25	7MB050001
AWWR-WFD012-C11	7WT010009	WFAE-035C-09M25	7MB050002
MFH Portable range		MFH Portable range	
AW-MFH010-C41	7MB021060	No change in designation and part number	
AW-MFH012-C41	7MB021061		
XDO Console range		XDOW Console range	
AW-XDO009-H11	7CW011020	XDOW-025R-01M25	7MB070001
AW-XDO012-H11	7CW011021	XDOW-035R-01M25	7MB070002
GCAO Water-cooled condensing range		YDOX Water-cooled condensing range	
GCAO 9N	7SP101040	YDOX-025R-09M25	Lancement mi-2022
GCAO 12N	7SP101041	YDOX-035R-09M25	Lancement mi-2022
GCAO 18N	7SP101045	YDOX-052R-09M25	Lancement mi-2022
GCAO 24N	7SP101044	YDOX-070R-09M25	Lancement mi-2022
DFO Water-cooled range		DFMO Water-cooled range	
AW-DFO005-H11	7OG091075	DFMO-022N-01M25	7MB030001
AW-DFO009-H11	7OG091076	DFMO-031N-01M25	7MB030002
AW-DFO017-H11	7OG091077	DFMO-041N-01M25	7MB030003
AW-DFO021-H11	7OG091078	DFMO-045N-01M25	7MB030004
AW-DFO031-H11	7OG091079	DFMO-080N-01M25	7MB030005
AW-DFO051-H11	7OG091081	DFMO-100N-01M25	7MB030006
AW-DFO071-H13	7OG091082	DFMO-170N-01T35	7MB030007
AW-DFO101-H13	7OG091084	DFMO-250N-01T35	7MB030008
AIRFLOW CMV range		AIRFLOW CMV range	
AW-AIRFLOW250-N91	7HP080005	JDAA-022R-09M25	7MB110001

TERTIARY R410A

CFM R410A On/Off Cassette range		CFMD R410A On/Off Cassette range	
AW-CFM012-N11	7SP042267	CFMD-035N-01M25	7SP042300
AW-CFM018-N11	7SP042268	CFMD-050N-01M25	7SP042301
AW-CFM024-N11	7SP042269	CFMD-070N-01M25	7SP042302
AW-CFM036-N11	7SP042270	CFMD-100N-01M25	7SP042303
AW-CFM048-N11	7SP042271	CFMD-140N-01M25	7SP042304
Panel		-	
Panel CBD/CBF/CCD /CDM/CFM 647x647	7ACVF0566	-	7ACVF0566
Panel CBD/CBF/CCD /CFM/CDM 950x950	7ACVF0564	-	7ACVF0600

Equivalences

OLD DESIGNATION	OLD PART NUMBER	NEW DESIGNATION	NEW PART NUMBER
DFM R410A On/Off Ducted range		DFMD R410A On/Off Ducted range	
AW-DFM018-N11	7SP032206	DFMD-050N-01M25	7SP033080
AW-DFM024-N11	7SP032207	DFMD-070N-01M25	7SP033081
AW-DFM036-N11	7SP033065	DFMD-100N-01M25	7SP033082
AW-DFM036T-N11	7SP032209	DFMD-100N-01T35	7SP033083
AW-DFM048-N11	7SP032210	DFMD-140N-01M25	7SP033084
AW-DFM060-N11	7SP032211	DFMD-160N-01M25	7SP033085
FFM R410A On/Off Floor ceiling range		FFMD R410A On/Off Floor ceiling range	
AW-FFM018-N11	7SP012268	-	-
AW-FFM024-N11	7SP012269	-	-
AW-FFM036-N11	7SP012295	FFMD-100N-01M25	7SP012310
AW-FFM036T-N11	7SP012270	FFMD-100N-01T25	7SP012311
AW-FFM048-N11	7SP012271	FFMD-140N-01M25	7SP012312
AW-FFM060-N11	7SP012272	FFMD-160N-01M25	7SP012313
YFFA R410A On/Off Outdoor unit		YFAD R410A On/Off Outdoor unit	
AW-YFFA012-H11	7SP063065	YFAD-035R-01M25	7SP063180
AW-YFFA018-H11	7SP063066	YFAD-050R-01M25	7SP063181
AW-YFFA024-H11	7SP063067	YFAD-070R-01M25	7SP063182
AW-YFFA036-H11	7SP063125	YFAD-100R-01M25	7SP063183
AW-YFFA036-H13	7SP063069	YFAD-100R-01T35	7SP063184
AW-YFFA048-H13	7SP063126	YFAD-140R-01T35	7SP063185
AW-YFFA060-H13	7SP063127	YFAD-160R-01T35	7SP063186
SFM R410A On/Off Floor standing range		SFMD R410A On/Off Floor standing range	
AW-SFM048-N13	7SP011290	SFMD-140N-01N35	7SP101061
AW-YSFM048-H13	7SP062859	YFAD-140R-01T35	7SP063185
HHF R410A On/Off High wall range		HHF R410A On/Off High wall range	
AWSI-HHF009-N11	7SP023146	AWSI-HHF009-N11	7SP023225
AWSI-HHF012-N11	7SP023147	AWSI-HHF012-N11	7SP023226
AWSI-HHF018-N11	7SP023148	AWSI-HHF018-N11	7SP023227
AWSI-HHF024-N11	7SP023149	AWSI-HHF024-N11	7SP023228
AWAU-YGF009-H11	7SP063057	AWAU-YGF009-H11	7SP063145
AWAU-YGF012-H11	7SP063058	AWAU-YGF012-H11	7SP063146
AWAU-YGF018-H11	7SP063059	AWAU-YGF018-H11	7SP063147
AWAU-YGF024-H11	7SP063060	AWAU-YGF024-H11	7SP063148

Equivalences

OLD DESIGNATION	OLD PART NUMBER	NEW DESIGNATION	NEW PART NUMBER
		HFLS R410A On/Off High wall range	
		HFLS-022N-01M25	7SP023260
		HFLS-025N-01M25	7SP023261
		HFLS-035N-01M25	7SP023262
		HFLS-050N-01M25	7SP023263
		HFLS-070N-01M25	7SP023264
		YFAS-022R-01M25	7SP063190
		YFAS-025R-01M25	7SP063191
		YFAS-035R-01M25	7SP063192
		YFAS-050R-01M25	7SP063193
		YFAS-070R-01M25	7SP063194



Sizing THE AIR CONDITIONING

STEP 1: EVALUATING THE NEEDS

In order to size properly your air conditioning installation, it's important to calculate the thermal needs of your habitation to calculate the power needed for your installation.

SIZING THE COOLING NEEDS BY OCCUPANCY RATIO

We use the following ratio to calculate the cooling capacity needed:

$$90 \text{ W/m}^2 + 100 \text{ W/Occupant}$$

The calculation is to be done room by room.

SIZING THE HEATING NEEDS BY THE G METHOD

The G is the volume loss coefficient of the building, corresponding to the total thermal losses through walls, windows, roofs... It's expressed in $\text{W/m}^3/\text{°C}$. This coefficient is related to the building insulation.

$$\text{Heating capacity (W)} = G \times V \times \Delta T$$

G = global loss coefficient ($\text{W/m}^3/\text{°C}$):

- ▶ 0.65 $\text{W}/\text{°C m}^3$ RT 2012 constructions
- ▶ 0.75 $\text{W}/\text{°C m}^3$ construction after 2000
- ▶ 0.9 $\text{W}/\text{°C m}^3$ constructions after 1980
- ▶ 1.2 $\text{W}/\text{°C m}^3$ moderately insulated constructions
- ▶ 1.8 $\text{W}/\text{°C m}^3$ poorly insulated constructions

V = building volume (m^3)

ΔT = Difference between indoor temperature (19 or 20°C), and average outdoor temperature in the region where the project is based.

STEP 2: OUTDOOR UNIT SELECTION

- ▶ Divide the cooling and heating needs calculated before (see step 1).
- ▶ Calculate the global needs by zone, in order to determine outdoor unit capacity.

STEP 2: EXTERIOR UNIT SELECTION			
Zone	Room	Cooling needed (kW)	Heating needed (kW)
ZONE 1	Room n°1		
	Room n°2		
	Room n°3		
	Room n°4		
	Room n°5		
	Room n°6		
	Total		
ZONE 2	Room n°1		
	Room n°2		
	Room n°3		
	Room n°4		
	Room n°5		
	Room n°6		
	Total		
ZONE 3	Room n°1		
	Room n°2		
	Room n°3		
	Room n°4		
	Room n°5		
	Room n°6		
	Total		

CALCULATION OF NEEDS

Example of simplified heat balance using the following formula:

$$D = G \times V \times \Delta T$$

- ▶ **D** = represents heat loss in Watts.
- ▶ **G** = is the volume ratio of heat loss, corresponding to the insulation of the house (in W/m³/°K).
- ▶ **V** = is volume of the house in m³.
- ▶ **ΔT** = is the difference between the basic outdoor temperature and the indoor temperature.

This balance does not replace the one performed by a design office, which is recommended for all types of installations, in particular for specific buildings (architecture, insulation, etc.).

EXAMPLES	
New-build (very well insulated)	G = 0.4
Insulated house	G = 0.9
Modern house	G = 1.0
Poorly insulated old house (standard wall)	G = 1.3
Veranda	G = 2.5 to 3.0

HEAT PUMP SELECTION

Select heat pump capacity depends on heat losses:

1 ▶ Sizing a HT heat pump and its electrical backup or boiler (ON/OFF bi-compressor solution)

- 70% of losses ≤ Heating capacity of the heat pump ≤ 100% of losses
- 120% of losses = Total power delivered by the heat pump + backup (electrical or fossil energy).
- Basic outdoor temperature ≤ Heat pump operating limit temperature - 5°C.

2 ▶ Sizing a LT heat pump and its electrical backup or boiler (DC Inverter bi-compressor solution)

- 80% of losses ≤ Heating capacity of the heat pump ≤ 100% of losses
- 120% of losses = Total power delivered by the heat pump + backup (electrical or fossil energy).
- Basic outdoor temperature ≤ Heat pump operating limit temperature - 5°C.

DHW POWER CALCULATION

Domestic Hot Water needs

NUMBER OF PEOPLE IN THE HOME	1	2	3	4	5
DAILY WATER NEEDS BY PERSON (IN LITERS OF WATER AT 40°C)	80 ± 35	60 ± 25	50 ± 20	45 ± 20	45 ± 20

Preparation with accumulation only: the DHW is produced in 6 or 8 hours.

Equivalent volume at 60°C:

$$V_{60} = V_x \frac{T_x - 10^\circ}{60^\circ - 10^\circ}$$

with: **T_x** = storage temperature of the DHW tank

V_x = water volume at storage temperature T_x

STEP 1 ▶ Energy drawn during the day

- ▶ It consists in calculating the maximum volume of hot water (equivalent to 60°C) drawn during the heaviest-laden day of the year.

- ▶ The energy drawn via hot water is given by the formula:

$$E_{acc} = 1.16 V_{60acc} (60^\circ - 10^\circ) / 1000$$

with: **E_{acc}** = energy drawn over a full day in kW/h

V_{60acc} = total hot water drawn during a day, including all usage, adjusted to 60°C, in liters

1.16/1000 = adjustment coefficient

10° = cold water temperature

STEP 2 ▶ Storing volume and exchanger capacity

- ▶ Storage tank volume given in liters by:

$$\text{Volume} = \frac{1000 \times E_{acc}}{1.16 \times (T_{ec} - 10^\circ) \times a}$$

with: **T_{ec}** = water temperature in the tank (between 55 and 60°C)

10° = cold water temperature, being the minimum temperature reached by the water in the tank while guaranteeing users comfort

a = storage efficiency coefficient (between 0.8 and 0.95)

- ▶ The exchanger capacity, given in kW by the following formula, allows to recover the hot water stock in 6 or 8 hours.

$$\text{Heat exchanger capacity (DHW)} = \frac{E_{acc}}{6 \text{ to } 8 \text{ h} \times 0.9} + P_{dis}$$

with: **P_{dis}** = losses in distribution circuit. In case of a distribution loop, it will be the power needed for maintaining the temperature in the loop.

0,9 = add-on factor, offsetting the storage losses during the stock restoration period

- ▶ Generally, a minimum power of 10 to 12 W/l per stored liter.

Sizing THE HYDRAULIC ACCESSORIES

BUFFER VOLUME

Airwell recommends a minimal water content that must be connected to the heat pump. This content:

- ▶ Ensures a sufficient inertia
- ▶ Maintains a minimum run compressor run time (anti-short cycle)

Approximate buffer volume for a low-temperature heat pump (runtime 6 min):

Heat pump power (in kW) under +7°C/35°C conditions	4	6	8	10	12	14	16
Power reduced to 20% for an Inverter heat pump (in kW)	1.2	1.8	2.4	3.0	3.6	4.2	4.8
Buffer capacity (in liters)	20	30	40	50	60	70	80

Approximate buffer volume for a high temperature heat pump (runtime 6 min):

Heat pump power (in kW) with +7°C/35°C conditions	4	6	8	10	12	14	16
Buffer volume capacity (in liters)	70	100	140	170	200	240	280

EXPANSION TANK

The expansion tank should be sized based on the heating mode, and consists in calculating:

- ▶ The inflation pressure
- ▶ Its capacity

The inflation pressure must be higher than the static pressure of the installation so that, on cold cycle, the water cannot enter the tank and the volume is optimum for absorbing the water expansion.

The tank capacity must be able to cope with the expansion volume of the installation.

For a pressure setting at 3 bars and a water installation at 45°C, we can use:

MAXIMUM CAPACITY OF THE INSTALLATION (IN LITERS)	EXPANSION TANK CAPACITY (IN LITERS) FOR A STATIC HEIGHT OF UP TO:		
	5 m	10 m	15 m
200	4	5	8
250	5	7	10
300	6	8	12
400	8	11	16
500	10	14	20

PEP ECOPASSPORT®



Airwell is part of an eco-environmental approach including a life cycle analysis of our products, and drawing up a Product Environmental Profile (PEP).

This life cycle analysis (LCA) allowed us to inventory and quantify, throughout the products life cycles, the physical material and energy flow associated with human activities. All the life cycle phases have been taken into account: raw materials, manufacturing, transport, distribution, usage, end of life and recycling.

The PEP meets the requirements of ISO 14025, 14040 and 14044. It allows us to anticipate the regulatory obligations, and forms part of the ecodesign approach which Airwell wants to follow. Finally, drawing up a POP allowed us to determine the environmental performance of some products.

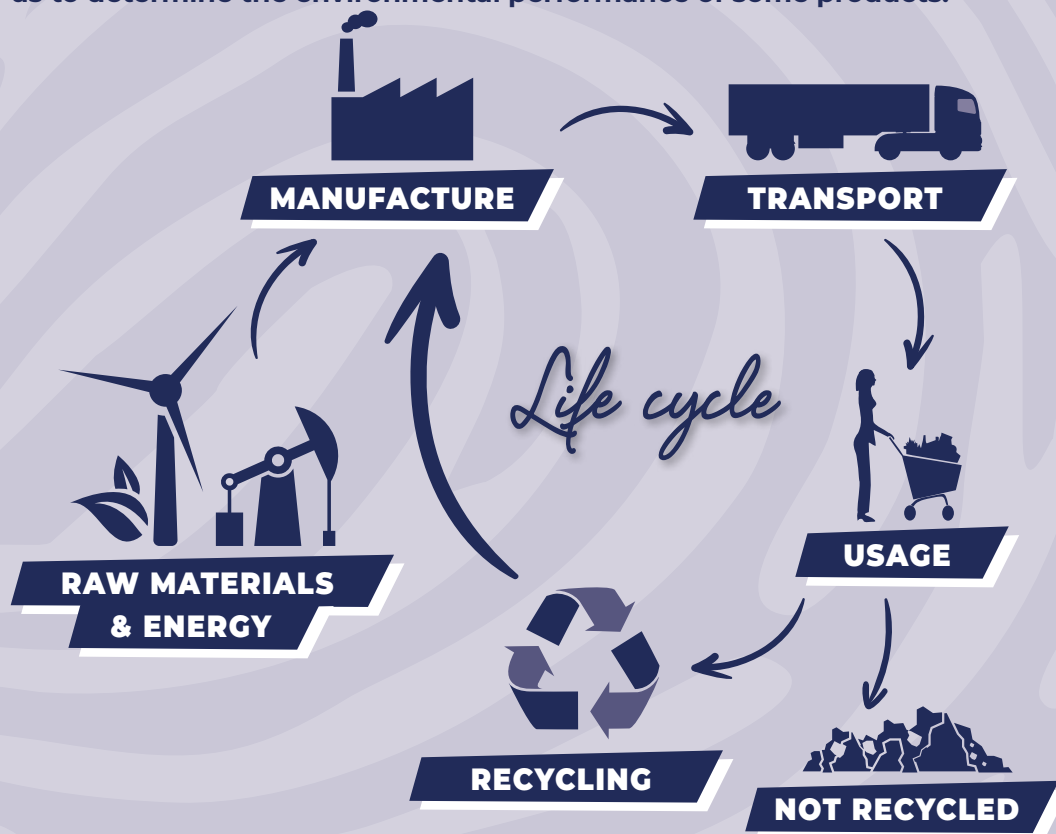

General recommendations for installing OF AIR/WATER HEAT PUMP

HYDRAULIC ACCESSORIES

Disconnecter on water system

- The regulations require a type CA or BA disconnecter installed on a power system of less than 70 kW connected to the drinking water network, depending on the heat transfer fluid used.

Safety valve

- The heat pump must be protected by at least one safety valve. It must be installed in an accessible place, in the immediate vicinity of the heat pump outlet pipe. There must be no isolating valves between the heat pump and safety valve.
- **Nota:** A safety valve is also necessary on the buffer tank, if equipped with a top-up electric heater.

Safety thermostat on the heating floor outgoing line

- Installing a safety thermostat on the heating floor outgoing line is mandatory. It must have a manual reset, operate mechanically without an electrical supply, and be independent from the regulation system.
- It must cut the heating supply to avoid the temperature in the heating floor to exceed 55°C. In case of a temperature exceeding 55°C it must stop the heat pump and top-up electric heater, as well as the circulator, and close the three way regulation valve.

Safety group

- The domestic hot water tank must be supplied in cold water via a safety group. There must be no branch connection or any elements between the safety unit and the water tank.

Expansion tank

- The expansion tank must be preferably upstream of the circulator.

Dirt separator and air bleed valve

- The installation must have a air bleed valve situated at the top point of the network. It is also advisable to equip the buffer tank. The automatic air bleed valve must be associated with an isolation valve.
- Dirt separator and sieve filter.
- It is highly recommended to install a dirt separator and filter sieve upstream of the heat pump, to protect it from sludging and maintain optimal heat exchange. The sieve filter must be at least equal in diameter to the circuit. Installing a drain valve is recommended, at the bottom of the buffer tank, so as to evacuate deposits.

Pressure gauges on circulators

- The pressure gauge located on each circulator must be associated with two isolation valves. It measures the pressure in the circulator, and evaluates the flow based on the specific curve of the circulator.



SNOWDRIFTS

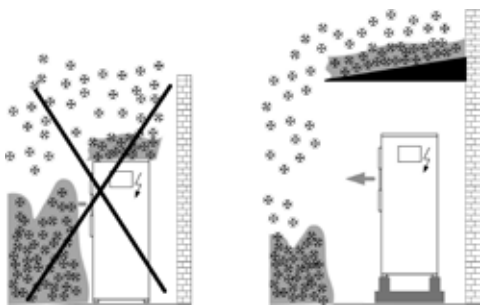

Provide a protection

CONDENSATE DISCHARGE

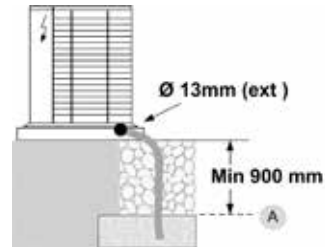

To avoid the water freezing downstream of the drain, lay the tube below the frost line (A).

STRONG WINDS

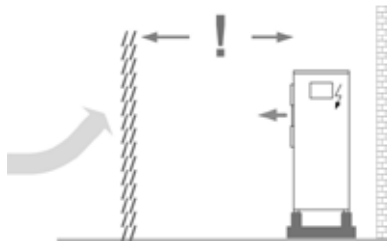

Provide windbreaks or similar

WATER FEATURES



< 15 °F. ?

If necessary, install water softener

WATER FEATURES | DOMESTIC HOT WATER REQUIREMENTS

The requirements vary by the number of people living in the building

* Possibility of adding auxiliary cylinder in case of high hot water request



Estimated average daily per capita consumption of hot water

Requirements	Liters - day - people (bathroom)	Liters - day - people (kitchen)
Low	Min.15 > max. 30	Min. 10 > max. 20
Medium	Min.30 > max. 60	Min. 20 > max. 40
High	Min.60 > max. 120	Min. 40 > max. 80

Example: average requirement for 4 people need about 230 litres/day

EXPANSION TANKS

Litres ? °C ?



Sizing expansion tanks according to the system features

A series of horizontal dotted lines for writing notes.

A series of horizontal dotted lines for taking notes.

A series of horizontal dotted lines for writing notes.

A series of horizontal dotted lines for writing notes.

Dotted lines for notes.

ARTICLE 1 - PURPOSE AND SCOPE

1.1. These general terms and conditions of sale apply to all sales of equipment and deliveries of services entered into by Groupe Airwell SA (hereinafter the "Vendor"), a public limited company (société anonyme) with a capital of 242,361.30 euros whose registered office is located at 10, rue du Fort de Saint Cyr, 78180 Montigny le Bretonneux, France, entered in the Versailles trade and companies register under number 824 596 795 from a professional buyer, understood as any natural or legal person, public or private, who acts for purposes within the framework of his commercial, industrial, craft, liberal or agricultural activity, including when they act in the name and on behalf of another professional. These general terms and conditions of sale are not applicable to a consumer or non-professional buyer.

1.2. "Equipment" refers to finished products, accessories, and spare parts.

1.3. Any order implies full and unconditional acceptance of these general terms and conditions of sale, which prevail over any other document of the buyer, particularly its general terms and conditions of purchase, unless otherwise expressly agreed beforehand by the Vendor.

1.4. If the Vendor does not invoke any one of the clauses of the general terms and conditions of sale at a given moment, this may not be interpreted as a waiver of its rights to invoke such clauses or these general terms and conditions of sale subsequently.

ARTICLE 2 - GENERAL INFORMATION: CATALOGUES, DOCUMENTATION

2.1. Because of the speed of the technological evolution and the evolution of standards or improvements regarding security in the field in question, any information, indication, or item of value transmitted on any medium, whether it comes from the manufacturer or the Vendor, is given for information purposes only. These parties reserve the right to make any modification to the equipment whose etchings, photographs, or drawings appear on such documents, at any time and without notice. No document provided by the Vendor is considered a contractual element, and the Vendor cannot be held liable for such documents.

2.2. Where the selection of the proposed equipment is done by the Vendor on the basis of information provided by the informed professional buyer, the buyer is always responsible for ensuring that the characteristics of the equipment proposed by the Vendor are actually suitable for its needs, with regard to both performance and the possibilities of implementation. In addition, if the buyer resorts to the collaboration of the Vendor's engineers or technicians for a study or project, the Vendor may not be held responsible, and the buyer undertakes to consult an expert in the field for, among other things, the selection and sizing of the equipment and its installation and commissioning.

2.3. The buyer must not modify the markings affixed on the equipment or packaging, add any other marking, or use the Vendor's markings, names, or trademarks in any way not expressly authorized.

ARTICLE 3 - ORDERS AND QUOTATIONS

3.1. Orders are firm. Once accepted, the order or quotation may only be modified or cancelled by the buyer with the Vendor's prior express consent. The buyer shall be liable for any order cancellation, even partial, and the Vendor shall be entitled to compensation in the form of a penalty set in the amount of the cancelled order, without prejudice to all other damages.

3.2. Any acceptance of an order or quotation must be written. Sales are final only after the express acceptance materialized by the Vendor's issue of an acknowledgement of receipt of the buyer's order. The Vendor reserves the right to accept or reject any order within a maximum of five business days from its receipt.

3.3. The buyer must check the acknowledgement of receipt of the order and report any error or omission to the Vendor within a maximum period of 48 hours from its receipt. Beyond this period, the order becomes final for the buyer. If a buyer places an order with the Vendor, without having paid for its previous order(s), the Vendor may refuse to honor the order and deliver the equipment in question, without the buyer being able to claim any compensation for any reason whatsoever.

3.4. The Vendor reserves the right, even after partial fulfilment of an order, to require guarantees or to cancel the order(s) or balances of orders in progress in the name of the buyer, without any compensation any kind, in the following cases: deterioration of the buyer's credit, failure to file documents and instruments with the registry of the commercial court, downgrading of the buyer's rating by the Vendor's credit department, refusal of a credit insurer or a factor to cover the amount of the sale, change or modification in the financial or legal capacity of the buyer, registrations or liens on the buyer's business or in general, in case of a change in the buyer's situation.

ARTICLE 4 - DELIVERY AND TRANSPORT

4.1. Unless there are provisions or an agreement to the contrary, the transport/delivery costs are borne by the purchaser. The reference incoterms are FCA vendor's warehouse or FOB port of shipment from the manufacturing plants.

4.2. The delivery lead times are given for information purposes only. In no case may exceeding the lead times justify the cancellation of the order or the awarding of damages. However, if the equipment still has not been delivered two months after a formal notice has remained unsuccessful, for any other cause other than force majeure (as defined in article 6.2), the order may then be cancelled at the request of either party; the buyer may obtain a refund of its advance payment to the exclusion of any other compensation or damages.

4.3. In accordance with Article 133-3 of the French commercial code, any delivered equipment that was not the subject of reservations by registered letter with acknowledgement of receipt within three days following the date of such receipt (not including holidays) to the transporter, a copy of which shall be simultaneously sent to the Vendor, shall be considered accepted by the buyer.

ARTICLE 5 - RECEIPT AND RETURN OF EQUIPMENT

5.1. Complaints about apparent defects or the non-conformity of the delivered equipment must be expressed in detail on the delivery slip and by registered letter with acknowledgement of receipt and sent to the Vendor's registered office within 72 hours following the delivery. Beyond this period, the received equipment shall be considered conforming to the order. It shall be up to the buyer to provide, with its complaint, any justification as to the reality of the noted defects or anomalies. The buyer shall give the Vendor every opportunity to investigate such defects and find a solution.

5.2. In any case, the buyer may not return the equipment without authorization from the Vendor. The Vendor shall be responsible for the costs and risks of the return solely in the event that an apparent defect or missing items are actually noted by it or its representative. If a claim proves justified, the return shall be the subject of an exchange or a credit memo, at the Vendor's choice, without the ability to demand any compensation or damages in any capacity whatsoever. Any return of equipment previously accepted due to the buyer, including but not limited to an order error or incorrect information communicated for a calculation or an order made by the buyer, will result in a discount to be defined according to the condition and/or antiquated or possible obsolescence of the returned product. The buyer shall be responsible for the return transport.

ARTICLE 6 - PRICE - TARIFFS - PRICE REDUCTIONS

6.1. Unless there are provisions or an agreement to the contrary, prices are set in euros net of tax and FCA vendor's warehouse for sales from the seller's stock, or FOB port of shipment from the manufacturing plants. For sales from manufacturing plants, a handling/freight/stuffing fee of 470 euros per container (regardless of container type) will be charged.

6.2. Equipment is sold on the basis of the Vendor's tariffs in force as at the date when each order is placed, or as at the date of issue of each quotation, subject to a delivery occurring no later than the end of the second calendar month following that date. Beyond that period, any price change before delivery shall be automatically applicable.

6.3. No discount shall be applied by the Vendor for cash payment or for payment earlier than the period indicated in these general terms and conditions of sale or on the invoice issued by the Vendor.

6.4. Unless otherwise agreed, the Vendor may grant the buyer dis-

counts on the prices in force, including in the form of premiums, at the time when the order is placed, depending on the turnover excluding taxes generated annually or over a given period, and/or the quantity/nature of the purchased finished products and/or services possibly rendered by the buyer. These discounts may be fixed and/or gradual and may vary according to the categories of buyers.

6.5. If one of the criteria for application of these price reductions or any one of the clauses of these terms and conditions of sale is not met, the elimination of the benefit of such price reductions shall be immediately retroactive over the entire year in question. Consequently, if price reductions have already been applied by the Vendor during the year in question, they must be returned by the buyer on simple request.

ARTICLE 7 - PAYMENT TERMS

7.1. For any company based outside France, invoices shall be payable according to the payment period negotiated and agreed by the Vendor. For all French companies, invoices are payable within a maximum period of 45 days, end of month, or 60 days from the invoice issue date. For summarised invoices issued at the end of the month, the period must not exceed 45 days from the invoice issue date (article L. 441-6 of the Code of Commerce).

7.2. The Vendor reserves the right to require one or more advance payments when the order is placed and/or before shipment. Any commercial paper (bill of exchange or promissory note) presented for acceptance must be returned within eight clear days of its receipt by the buyer.

7.3. In accordance with Articles L. 441-3, L. 441-6, and D. 441-5 of the French commercial code, any payment delay automatically results in, in addition to late payment penalties at a rate equal to three times the statutory interest rate (i.e., 0.77% in the second half of 2022 updated each half-year period by the Minister of the Economy, with the understanding that this rate shall apply to the amount of the invoice including all taxes), an obligation for the debtor to pay 40 euros in recovery charges if the invoice has not been settled on the day following the payment date appearing on the invoice. In addition, in case of a late payment or a partial payment, (i) the Vendor may suspend all current and/or future orders; (ii) 48 hours after a formal notice has remained unsuccessful, the sale shall be automatically terminated, if so desired by the Vendor, which may bring action for summary proceedings for the return of the equipment, without prejudice to any other action and/or damages. The buyer must reimburse all costs caused by the non-payment (including return costs on unpaid debts) and the recovery of sums due, including fees of ministerial officers and/or recovery companies.

7.4. In no case may payments be suspended or offset without the Vendor's prior written approval. Any partial payment shall first be applied to the non-preferential part of the debt, then on the amounts with the earliest due date.

ARTICLE 8 - RETENTION OF TITLE AND TRANSFER OF RISKS

8.1. The transfer of ownership of the equipment is subject to the full payment of the price by the buyer. The buyer undertakes to maintain the equipment in good condition and insure it against all risks, for which the buyer shall be fully responsible in all cases, as from their delivery. In order to permit any action for recovery by the Vendor, the buyer must ensure that the equipment can be individually identified.

8.2. The Vendor may recover its equipment regardless of whose possession it is in, in case of non-payment of the price by the buyer or insolvency concerning it, even when such equipment has been handed over to a third party. If the equipment resold, the buyer must notify the new buyer of the existence of the retention of title clause.

ARTICLE 9 - LOCAL STANDARDS AND COMPLIANCE

9.1. As concerns European countries subject to the FGAS EU517/2014 regulation, the importer of the products bears sole liability to the European authorities for the declaration of the FGAS quotas. Therefore, for orders from Airwell's central stock located in France, the FGAS quotas are declared by Airwell; no further action is to be taken by Airwell customers. For drop-shipped orders, imported directly from plants outside of Europe, the Airwell customer importing this order bears sole liability for the declaration of the FGAS quotas to the relevant authorities. The latter must complete the declara-

tion paperwork in its own country. Airwell may, at the customer's request, sell and transfer FGAS quotas but Airwell shall not be held liable under any circumstances for a failure to declare quotas or any error in the quantities declared. The importing customer bears sole liability for the declaration of FGAS quotas.

9.2. Any entry of goods into the European Union or a third country is the sole responsibility of the importer. In this sense, the buyer is solely responsible for ensuring the conformity of the products he imports. Airwell cannot be held responsible if the products do not conform to the local standards when they enter the "destination" territory (release for consumption). The buyer must provide in advance all the documents necessary for the conformity of the imported products on the territory of "destination" (release for consumption). Airwell strongly recommends a pre-departure inspection of the goods, at the customer's (buyer's) expense, to ensure the conformity of the imported goods. After research and analysis, Airwell reserves the right to refuse the order or to modify the pricing.

ARTICLE 10 - ASSIGNMENT OF JURISDICTION - APPLICABLE LAW

These general terms and conditions of sale are subject to French law. Any dispute shall be under the exclusive jurisdiction of the VER-SAILLES COMMERCIAL COURT, even in case of interim proceedings, incidental claims, or multiple defendants or introduction of third parties.

ARTICLE 11 - INTELLECTUAL PROPERTY

11.1. The buyer is authorized, on a precarious basis, to use the brand, the commercial name, the sign, the graphic elements and other distinctive signs relating to the Vendor's equipment for the sole purpose of identifying and promoting them and in the exclusive interest of the Vendor. This right of use does not confer any ownership rights to the buyer. The buyer undertakes not to register and not to be the owner of trademarks, models, domain names, patents, signs, trade names, product references and other distinctive signs belonging to the Vendor (or of which it has the use) or which could lead to confusion with its own.

11.2. With regard to the Vendor's graphic elements, such as logos or photographs, the buyer undertakes to use and reproduce them only and reproduce them only in strict compliance with the quality of the image and the format of the original graphic elements. The buyer shall not modify them or use them in such a way as to degrade the brand image of the Vendor or those image of the Vendor or of his equipment.

11.3. The buyer's right to use the Vendor's trademarks, trade names or other distinctive signs shall cease immediately when the business relationship with the Vendor ceases for any reason whatsoever. The same applies to non-compliance by the buyer with the conditions of use described in this article may result in the termination of this right of use at any time by of use at any time by simple letter.

ARTICLE 12 - PROTECTION OF PERSONAL DATA

12.1. Any order for equipment implies the processing, by the Vendor, of personal data within the meaning of European Regulation 2016/679 of 27 April 2016 and Law No. 78-17 of 6 January 1978 relating to data processing, files and freedoms in its current version (hereinafter collectively the "Applicable Laws"), which relate to the buyer and/or the natural person, representative of the buyer, who places the order in the name and on behalf of the buyer.

12.2. The Vendor declares that it complies with the Applicable Laws and, in particular, implements the principles of personal data protection, notably the principles of lawfulness, proportionality, transparency and data minimization as set forth in the Applicable Laws.

12.3. The manner in which such data is collected and processed by the Vendor, as well as a description of the buyer's rights with respect to such data, are set out in the privacy policy adopted by the Vendor and available on its website at the URL <https://www.airwell.com/en/privacy-policy/>.

12.4. The Vendor's privacy policy is an integral part of these terms and conditions of sale.

THESE GENERAL TERMS AND CONDITIONS MAY BE SENT TO YOU IMMEDIATELY IN BOLD CHARACTERS ON SIMPLE REQUEST. AS THESE TERMS AND CONDITIONS ARE ESSENTIAL TO THE VENDOR'S COMMITMENT, WE INVITE YOU TO CONTACT US IF THEIR READABILITY IS NOT SUITABLE FOR YOU.



TECHNOLOGY



FLEXY MATCH

Indoor units are compatible with monosplit or multisplit installation.



DC INVERTER

Compressor with high efficiency DC engine.



R410A FLUID

R410A Refrigerant.



R32 FLUID

R32 Refrigerant.



R407C FLUID

R407C Refrigerant.



R290 FLUID

R290 Refrigerant.



R134A FLUID

R134A Refrigerant.



ELECTRONIC EXPANSION VALVE

Precise control of refrigerant flow, optimized of performance and compressor protection.



4D AIRFLOW

Optimized heating and cooling operations, with an automatic horizontal and vertical swing.



MULTIFLOW 360°

4-direction air distribution system with great comfort through 360°, with motorized opening control.



GOLDEN FIN CONDENSER

Improve heat transfer efficiency and corrosion resistance.



COMPATIBLE HYBRID HOUSE

Product compatible with the Hybrid House option.

AIR QUALITY/CLEAN



IONIZER

Generates sterionizer ions producing electrochemical reaction destroying bacteria, viruses and allergenic particles. Creates and ensure provisioning of natural and high quality air in living environment.



NANO PHOTOCATALYTIC FILTER

Oxidizes and degrades organic contaminants. It can eliminate up to 99.9% of bacteria and can efficiently at blocking dust.



AIR FILTER

Eliminates fine particles and purifies the air.



AUTO CLEAN/DRY

Prevents development of bacteria and moistures keeping the heat exchanger dry after a cooling operation.



FRESH AIR

Cools the room by bringing fresh air from outside.

USER FUNCTIONS



I FEEL

Precise temperature control all around the chosen zone via a remote temperature sensor.



NIGHT MODE

Temperature in the room adjusted based on sleeping habits.



QUIET MODE

Top design for the lowest sound level.



REFRIGERANT LEAKAGE DETECTOR

Indicates a refrigerant leakage on indoor unit and stops the system for compressor protection.



PROGRAMMABLE TIMER

Timer set to switch the unit on and off.



TIMER

Timer for switching the appliance on or off.



AUTO RESTART (MEMORY)

Automatically restarts the unit in the last used mode when power is restored.



REMOTE CONTROL LOCK

Locks the remote functions to avoid inadvertent actions.



WI-FI

Air conditioner controlled via smartphone, tablet or computer through a wireless router and internet, thanks to AirHome app.



REDUNDANCY FUNCTION

Product compatible with Astrwell redundancy solution.

INSTALLER FUNCTIONS



ERROR CODE VIA INDOOR UNIT

Digital display of error codes or temperature settings on the indoor unit.



AUTO-DIAGNOSTIC

Unit failure indicated by a blinking led on the unit display.



BUILT-IN CONDENSATE PUMP

Eliminates condensate, for a simple and smooth running.



LEFT/RIGHT DRAIN CONNECTION

Easy-to-install condensate tubing, either on the left or right side.



ALARM OUTPUT

Remote transmission of malfunctions.



DRY CONTACT ON/OFF

Connection to a detection accessory (room card, presence detection, window...) to make energy savings.



BMS COMPATIBLE

Connection to the BMS system.



SERVICE MONITOR TOOL

Local interface for monitoring the operating parameters.



POWER CONSUMPTION CONTROL

Energy consumption control reducing the unit's energy consumption.



OUTDOOR UNIT NIGHT MODE DRY CONTACT

Outdoor unit speed limitation and noise level reduction.



OUTDOOR UNIT STAND-BY

Power on or power off of the outdoor unit from the remote.



OUTDOOR UNIT ALARM OUTPUT

Transmission of an air output fault alarm to a remote system.



TECHNICIAN TEST MODE

Special mode optimizing the technician's intervention time.



HEATING MODE ONLY

The unit can be configured in heating only mode.



AUXILIARY HEATER

Relaunches the heating capacity when the systems runs at a very low ambient temperature.

HEATING RANGE



WEEKLY TIMER

Program a scenario that will be automatically executed by the device on a weekly basis.



UNIT ON/OFF OUTPUT

Option displaying the unit's power status on the remote control.



COOLING MODE OPERATIONAL UP TO 43°/46°C OUTDOORS

Operation in cooling mode even at very high outside temperature, thanks to the special design of the unit.



HEATING MODE OPERATIONAL DOWN TO -20°/-25°C OUTDOORS

Heating mode available even at very low outdoor temperatures, thanks to the special design of the unit.



HIGH TEMPERATURE UP TO 55°/60°C

High temperature production up to 60°C.



DOMESTIC HOT WATER

Production of domestic hot water.



FLOOR HEATING

Connection available with a low-temperature transmitter.



HIGH-TEMPERATURE RADIATOR

Connection available with a high-temperature transmitter.



LOW-TEMPERATURE RADIATOR

Connection available with a low-temperature transmitter.



BOILER REPLACEMENT

Replace an old, energy-consuming boiler with an efficient Airwell heat pump.



BOILER BACK-UP

Complement a boiler with a heat pump.



WATER PROGRAMS

The regulator maintains the heat pump power in accordance with a water logic based on outdoor temperature.



CEE

The product is CEE certified.



RENEWABLE ENERGY

The product is compatible with renewable energy standard.



KEYMARK CERTIFICATION

The product is Keymark certified.

AIRWELL, MAIN PARTNER OF **STADE FRANÇAIS PARIS**

Airwell



A COMMITTED PARTNERSHIP

Airwell, a French player committed to the energy transition, has chosen Stade Français Rugby for its first sports partnership, to represent their common values, in particular in terms of the ecological and environmental transitions.



AFTER-SALES
SERVICE

+33 (0)1 76 21 82 95

Monday to Friday 9 am-12:30 pm / 2 pm-5 pm

TECHNICAL SUPPORT

sav@airwell.com

GROUPE AIRWELL

10, rue du Fort de Saint Cyr - 78180 Montigny-le-Bretonneux, FRANCE

Tel: +33 (0)1 76 21 82 00 - www.airwell.com

Printed in France