



Installation Manual

TFHX-YFHX

Heat pump water heater split

EN



Dear Customer,

Thank you for purchasing this device.

We invite you to read this manual carefully before using your appliance. Keep this document in a safe place for future reference.

To ensure safe and efficient operation, we recommend that you carry out the necessary maintenance operations regularly. Our After-Sales service can help you with these operations.

We hope that you will be satisfied with our services for many years.

AIRWELL

The data contained in this manual are not binding and may be modified by the manufacturer without prior notice.

SUMMARY

1.	SAFETY INSTRUCTIONS	5
1.1.	General safety instructions	5
1.2.	General warnings.....	7
1.2.1.	Risk situations.....	7
1.2.2.	Intended use.....	7
1.2.3.	Hydraulic circuit.....	8
1.2.4.	Electrical circuit	8
1.2.5.	Modifications.....	9
1.2.6.	Breakdown or malfunction.....	9
1.2.7.	User training.....	9
1.2.8.	Updating data	9
2.	INTRODUCTION	10
2.1.	Warnings.....	10
2.1.1.	Installation.....	10
2.1.2.	Hydraulic connection.....	10
2.1.3.	Electrical connection	10
3.	PRESENTATION	11
3.1.	Packaging.....	11
3.2.	Handling.....	12
3.3.	Dimensions	13
3.3.1.	Water tank.....	13
3.3.2.	Outdoor unit.....	14
4.	INSTALLATION	16
4.1.	Water tank installation.....	16
4.2.	Outdoor unit installation.....	17
4.3.	Hydraulic connection.....	19
4.3.1.	Cold water connection	19
4.3.2.	Hot water connection.....	20
4.3.3.	Condensate evacuation.....	20
4.4.	Refrigeration connection.....	21
4.4.1.	Connecting the refrigeration connections to the outdoor unit	22
4.4.2.	Vacuum test.....	22
4.4.3.	Filling	23
4.4.4.	Additional charge	23
4.5.	Electrical connection	24

4.6.	Filling the water heater	24
5.	COMMISSIONING	25
5.1.	Verification before 1st commissioning.....	25
6.	CONTROL PANEL.....	26
6.1.	Setting the clock	27
6.2.	Operating modes.....	28
6.2.1.	ECON MODE	28
6.2.2.	AUTO MODE	28
6.2.3.	HEATER MODE.....	28
6.3.	Time programming.....	28
7.	ERROR CODES.....	29
8.	OPERATING PARAMETERS.....	30
9.	SERVICE.....	32
10.	WATER QUALITY	32

1. SAFETY INSTRUCTIONS

1.1. General safety instructions

The precautions in this manual are subdivided as shown at right.

They are important, so it is recommended to respect them scrupulously.

Be sure to read these instructions carefully before installing.

Be sure to keep this manual handy so that you can refer to it at any time if needed.

The unit covered by this manual contains fluorinated gases. For specific information on the type and quantity of gas, refer to the data label applied to the unit.

Contact the dealer for any assistance.

ATTENTION

The unit can be used by children from the age of 8 and by people with reduced physical, sensory or mental capacities or without sufficient experience or knowledge, provided that they are supervised or have received the necessary instructions relating to safe use of the device and have understood the associated dangers. Children should not play with the device. Cleaning and maintenance operations must not be carried out by children without supervision.

Before cleaning, stop the unit and turn off the switch or unplug the power plug.

Failure to observe this precaution may result in a risk of injury or electric shock.

DANGER

Do not insert fingers, bars or other objects into the air inlets or outlets.

Any contact with the fan, when it is rotating at high speed, can cause injury.

Do not touch the interior parts of the regulator.

Do not remove the front panel. Any contact with certain interior parts is dangerous or may cause faults in the appliance.

Meaning of DANGER, WARNING, CAUTION and NOTE.

DANGER

Indicates an imminently hazardous situation which, if not avoided, will result in death or serious injury.

WARNIG

Indicates a potentially hazardous situation which, if not avoided, could result in death or serious injury.

ATTENTION

Indicates a potentially hazardous situation which, if not avoided, may result in minor or moderate injury. This term can also be used as a warning in case of insufficiently safe procedures.

NOTE

Indicates situations that may cause only accidental damage to equipment or other property.

DANGER

Do not use flammable sprays such as hair sprays or paints near the unit as this may cause a fire.

Do not remove, cover or alter any instructions, permanent labels or data label present on the outside of the unit or inside its panels.

Use of the device is prohibited for children and unassisted disabled persons.

It is forbidden to touch the device with bare feet and wet body parts.

Any cleaning operation is prohibited as long as the device has not been disconnected from the electrical supply network by setting the main switch of the installation to "off".

It is forbidden to pull, detach, twist the electrical cables coming out of the device even if the latter is disconnected from the power supply network.

It is forbidden to climb on the device and/or to place objects of any kind on it.

It is forbidden to spray or throw water directly on the device.

It is forbidden to introduce pointed objects through the air intake and delivery grilles.

It is forbidden to open the access doors to the interior parts of the appliance without having first set the main switch of the installation to "off".

Do not disconnect the power.

WARNING

If the power cable is damaged, it must be replaced by the manufacturer, his representative or a qualified person.

Wiring should be carried out by professional technicians in accordance with national wiring regulations.

In the fixed wiring, a disconnecting device must be incorporated in all the poles with a separation distance between the poles of at least 3 mm as well as an earth leakage circuit breaker (RCD) with a nominal value greater than 10mA.

The system automatically shuts down or restores heating.

The unit must always be powered to allow water heating, except for the duration of assistance and maintenance interventions.

Keep this manual and the wiring diagram in a place accessible to the operator.

Supervise children to ensure they do not play with the unit.

WARNING

Write down the identification data of the unit so that it can be provided to the assistance center in the event of an intervention request (see the "Unit identification" paragraph).

Provide a booklet to record the interventions carried out on the unit. This will make it easier to establish the appropriate frequency of the various interventions and to carry out any troubleshooting.

Exposure to water temperature above 50°C can cause severe immediate burns or death from burns.

Children, people with disabilities and the elderly are the subjects at the highest risk of burns. Touch the water before taking a bath or shower

It is recommended to use a mixing valve for the water temperature.

The moving, repair and maintenance of the unit must be entrusted to a qualified person: do not carry out these operations alone.

In the event of a breakdown or defect:

- immediately deactivate the unit.
- contact an approved assistance centre.
- request the use of original spare parts.

Ask the installer to tell you how to make the following settings:

- on/off
- modification of setpoints
- put to rest
- maintenance
- what to do/not to do in the event of a breakdown .

1.2. General warnings

Read the user manual carefully and use the unit strictly in accordance with the instructions provided to avoid personal injury, damage to the unit, damage to property and legal disputes. Our company assumes no legal responsibility for any damage caused by improper use of the unit. The location, the hydraulic, refrigerant, electrical circuit and the air ducts must be decided by the designer of the installation or by a person competent in the matter, taking into account purely technical requirements as well as any local legislation. in force, which provide for obtaining specific authorizations.

Only a qualified professional can work on the unit, as provided for by the regulations in force. The use of the unit in the event of a breakdown or defect:

- voids the warranty
- may compromise the safety of the unit
- can increase repair costs and times.

For any operation, respect the local safety rules.

Keep the packaging material out of the reach of children as it is a potential source of danger.

Recycle and dispose of packaging material according to local regulations.

1.2.1. Risk situations

The unit is designed and manufactured in such a way as not to expose the health and safety of persons to risks.

In the project phase, it is not possible to intervene on all the causes of risk. Read the "Residual risks" section which mentions the situations that may involve risks for people or property. Installation, commissioning, maintenance and repair require specific knowledge; if inexperienced personnel handle it, it may cause damage to persons or property.

1.2.2. Intended use

The unit is designed for: domestic hot water heating only, respecting the limits provided for in the technical bulletin and in this manual.

Any other use does not involve any commitment or constraint of any kind for the manufacturer.

1.2.3. Hydraulic circuit

Components

Selection and installation of circuit components should be done by the installer.

Water quality

The water quality can be checked by specialized personnel. The factors to be analyzed are:

- Inorganic salts
- pH
- Biological contaminants (algae, etc.)
- Solids in suspension
- Dissolved oxygen

Water with unsuitable characteristics can cause:

- Increase in pressure drops
- Decreased energy efficiency
- Increase in corrosion phenomena

Risk of frost

Take measures to prevent the risk of freezing if the unit or the relative hydraulic connections can be subjected to temperatures close to 0°C.

The unit is intended for permanent connection to the water supply network and must not be connected with flexible pipes.

Water can drip from the relief valve discharge pipe and this pipe should be left open to the atmosphere.

The safety valve must be actuated regularly to remove lime deposits and to check that it is not blocked.

The discharge pipe connected to the safety valve must be installed in a continuous downward direction and in a frost-free location.

1.2.4. Electrical circuit

The characteristics of the lines must be established by personnel authorized to design electrical circuits, in compliance with the regulations in force. Always operate in accordance with the safety rules in force.

To avoid the risk of death or injury, before using the unit, plug it into a grounded outlet.

Do not install the unit if it is not possible to verify that the grounding of the domestic network concerned meets the regulations in force.

Power must be supplied through an independent circuit at rated voltage.

The power circuit must be effectively grounded.

Do not use the water pipes for the connection of the earthing of the unit. To carry out the required operations, wear personal protective equipment: gloves, goggles, etc.

The section of the power supply cables and of the protection cable must be determined according to the characteristics of the protections adopted.

The serial label provides specific electrical data for the unit, including any electrical accessories.

Connections

All operations of an electrical nature must be carried out by personnel with the prerequisites provided for by the regulations in force and informed of the risks associated with these operations.

Refer to the electrical diagram of the unit (the electrical diagram number is indicated on the serial plate). Check that the characteristics of the network comply with the data given on the serial number plate.

Protect the cables using cable glands of adequate dimensions.

Before starting work, check that the sectioning device at the start of the unit's power supply line is open, blocked and fitted with the appropriate signaling panel.

First make the ground connection.

After connecting the wires, recheck and make sure the connection is good before turning on the unit. Before powering up the unit, make sure that you have refitted all the protections that were removed during the electrical connection work.

Signal/data lines - laying

Do not exceed the maximum allowable distance, which varies depending on the type of cable and signal.

Lay the cables away from power lines, with a different voltage, or which emit disturbances of electromagnetic origin. Avoid laying the cables close to devices that may create electromagnetic interference.

Avoid laying in parallel with other cables; any crossings with other cables are allowed only if they are at 90°.

The protective screen must be connected to an earth free from disturbances.

Guarantee the continuity of the protective screen over the entire extension of the cable.

Respect the indications concerning the impedance, the capacity, the attenuation.

1.2.5. Modifications

Any type of modification made to the unit voids the warranty and discharges the manufacturer's liability.

1.2.6. Breakdown or malfunction

Disable the unit immediately in the event of a breakdown or malfunction.

Contact a service center authorized by the manufacturer.

Request the use of original spare parts.

1.2.7. User training

The installer must instruct the user, particularly with regard to:

- On/off;
- Modification of set points;
- Resting
- Maintenance ;
- What to do/not to do in the event of a breakdown.

1.2.8. Updating data

Continuing product improvements may result in changes to the data shown in this manual.

Consult the manufacturer's website for up-to-date data.

2. INTRODUCTION

2.1. Warnings

2.1.1. Installation

CAUTION: Heavy product to be handled with care:

1/ Install the device in a place protected from frost. The destruction of the device by overpressure due to the blocking of the safety device is out of guarantee.

2/ Make sure that the partition is capable of supporting the weight of the appliance filled with water.

3/ If the device must be installed in a room or location where the ambient temperature is permanently above 35°C, provide ventilation for this room.

4/ In a bathroom, do not install this product in volumes V0, V1 and V2. If the dimensions do not allow it, they can nevertheless be installed in volume V2.

5/ This product is intended for use at a maximum altitude of 2000 m.

6/ Place the device in an accessible place.

7/ Refer to the installation figures in the Installation chapter.

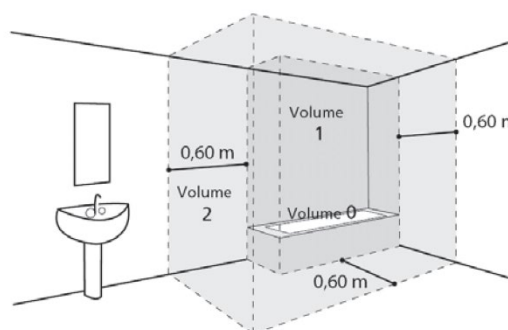

2.1.2. Hydraulic connection

It is mandatory to install a new safety device, $\frac{3}{4}$ " in size and 0.7 MPa (7 bar) pressure on the water heater inlet, protected from frost, which must comply with the local standards in force.

A pressure reducer (not supplied) is necessary when the supply pressure is greater than 0.5 Mpa (5 bar) which will be placed on the main supply.

Connect the safety device to a drain pipe, maintained in the open air, in a frost-free environment, sloping continuously downwards for the evacuation of the water from the expansion of the heater or the water in the event of water heater drain.

It is essential to install a retention tank under the water heater when it is positioned in a false ceiling, in the attic or above inhabited premises.

A drain connected to the sewer is necessary.

2.1.3. Electrical connection

Before removing the cover, ensure that the power supply is switched off to avoid any risk of injury or electrocution.

The electrical installation must include, upstream of the appliance, an omnipolar cut-off device (circuit breaker, fuse) in accordance with the local installation rules in force (30mA differential circuit breaker).

Refer to the wiring diagrams on the back cover.

Grounding is mandatory. A special terminal bearing the mark



is provided for this purpose.

3. PRESENTATION

3.1. Packaging

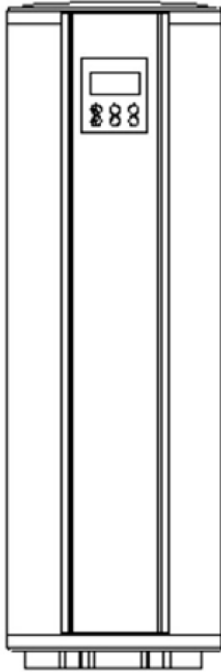

Water tank



1 installation & user manual



Condensate drain pipe



Anti-vibration feet (4p)

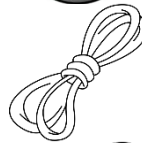

Temperature probes (2p)

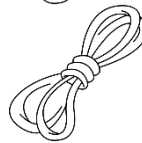

Communication cable (1p)

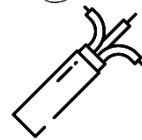

Power cable for electric heater (1p)



Insulation sleeve for refrigeration connection (2p)



Condensate drain connection (1p)

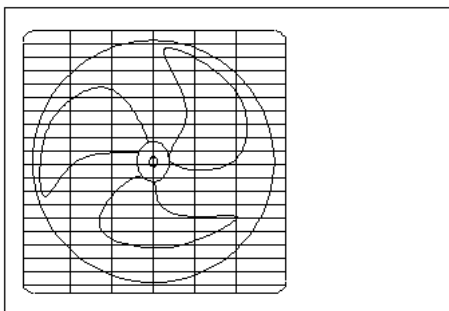

Outdoor unit

3.2. Handling

The water tank can be transported horizontally.

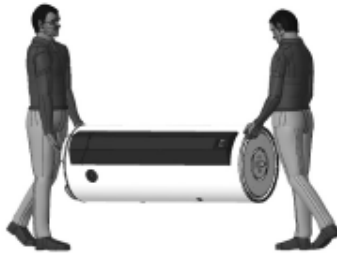

The outdoor unit must be transported upright. It cannot be in any other direction than that indicated on the card.

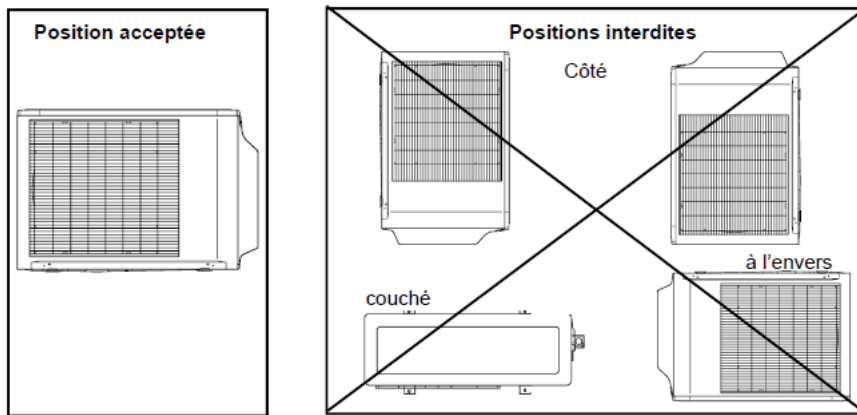

3.3. Dimensions

3.3.1. Water tank

	200 L
Cold water inlet height	270 mm
Hot water outlet height	1316 mm
Liquid pipe height	650 mm
Gas pipe height	720 mm
Total height	1580 mm
Weight	62 kg

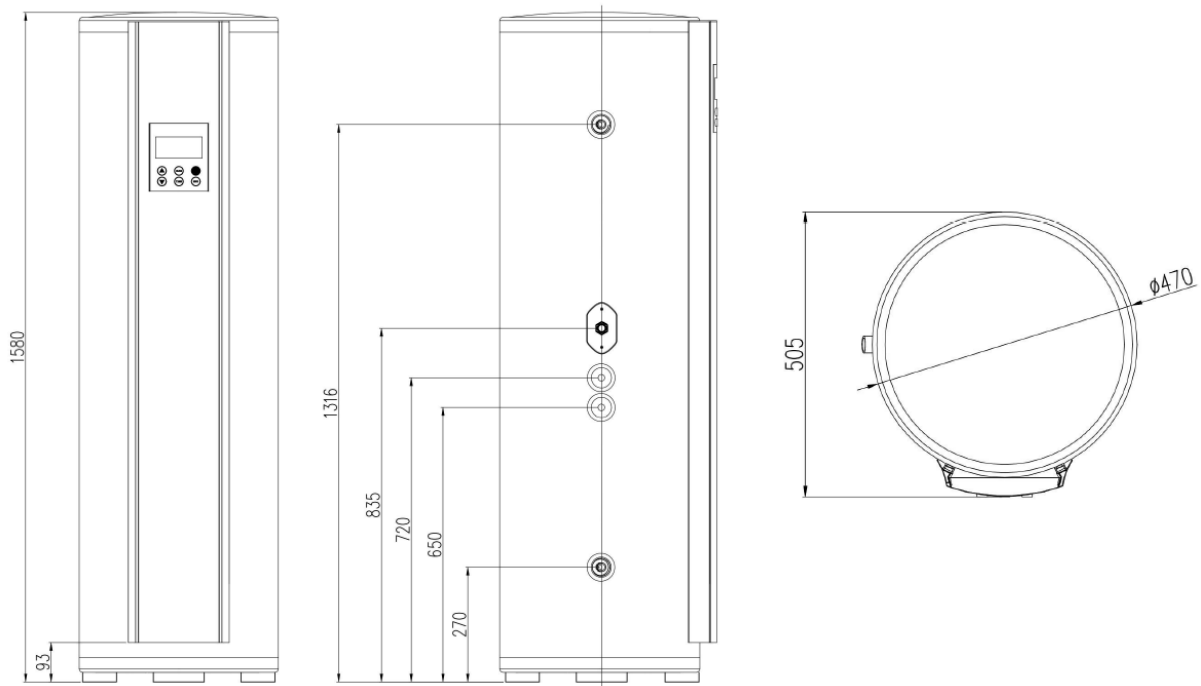



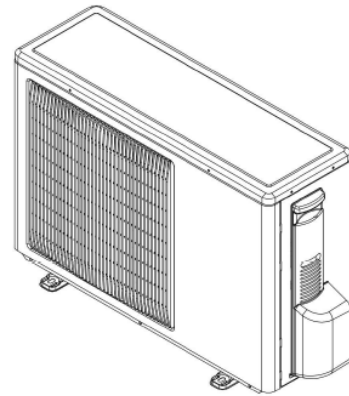
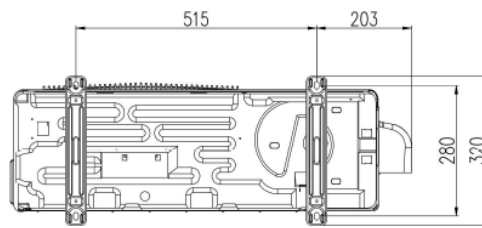
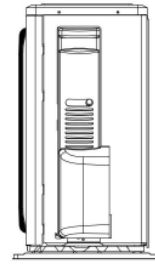
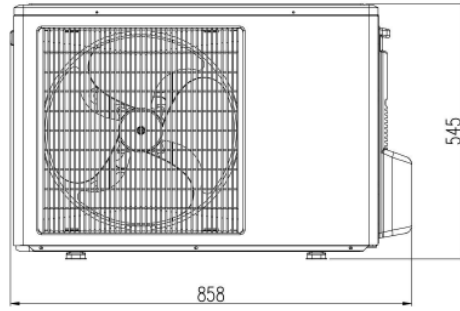
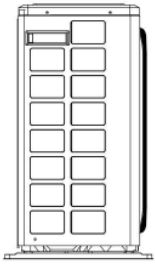

3.3.2. Outdoor unit



3.4. Accessories

The following accessories are not supplied with the device. You can find them in our catalog or from your wholesaler.

3/8" and 1/4" diameter copper connection.	
Support for flat ground	
Black rubber support	
Support for uneven floor	
Wall bracket for outdoor unit	

4. INSTALLATION

4.1. Water tank installation

NOTE

It is strongly recommended to install a water retention tank connected to the drain under the water heater when it is positioned above inhabited premises.

The identification label must be accessible at all times.

Before filling, the water heater must be leveled by shimming it if necessary.

The water heater must be installed on a smooth and horizontal floor and must not be in contact with a wall.

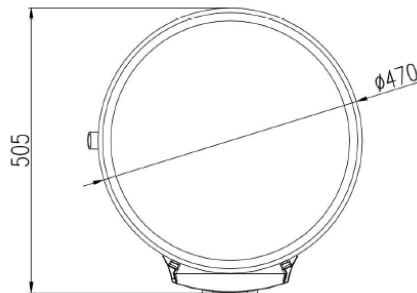

ATTENTION

The water heater must (in accordance with article 20 of standard EN 60335-1) be fixed to the ground.

There are 3 possible installation configurations:

- 1 - Unsheathed Interior/Interior*
- 2 - Exterior/Exterior sheathing*
- 3 - Interior/Exterior sheathing*

Regardless of the installation configuration chosen, the installation location must comply with the IP X1B protection index, in accordance with the requirements of NFC 15-100.

The floor must hold a load of at least 500 kg (surface under the water heater).

4.2. Outdoor unit installation

- Fix the outdoor unit firmly, if it is exposed to strong winds.
- Install the outdoor unit in a place capable of supporting its weight and which does not propagate vibrations, and where it can be installed horizontally.
- Check that the space around the unit is sufficient to ensure good air circulation.
- The outdoor unit must be installed outside any building.

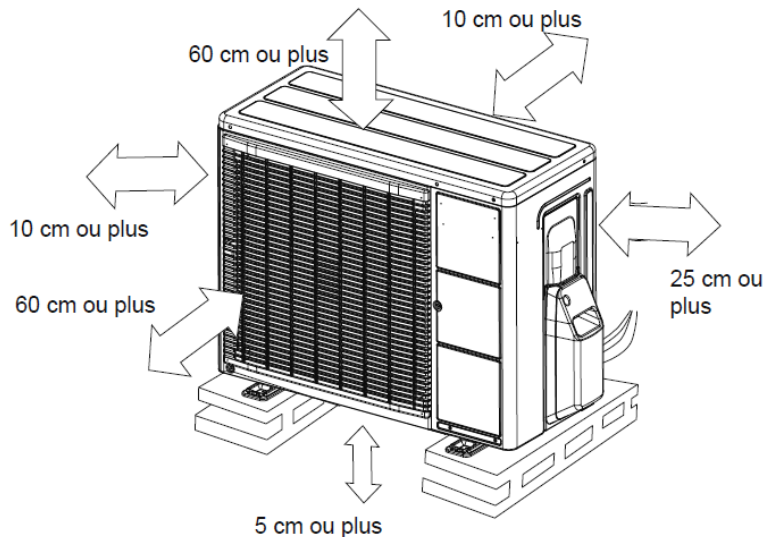

- Do not install the unit near a source of heat, steam or flammable gases.
- During operation, condensation water drips from the unit. Make sure that this water drains away unhindered and without causing damage to buildings. In particular, if the appliance is simply placed on the ground, the simple fact of raising it slightly (5 cm minimum) allows good drainage.
- Do not install the unit in a place exposed to strong winds or dust.

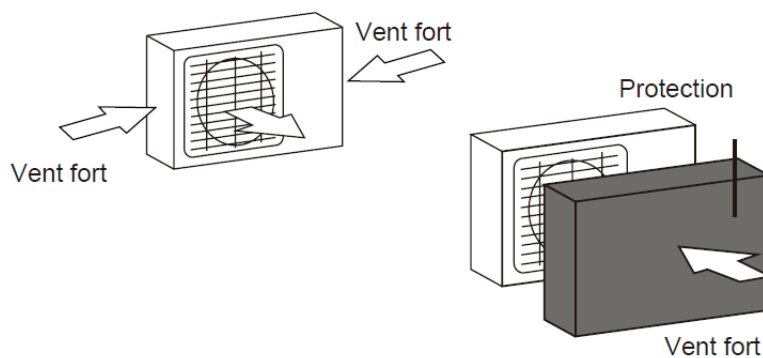

- Avoid installing the unit in a location where it may be subject to heavy soiling or dripping water.

- In frequently snowy areas, the outdoor unit should be elevated.

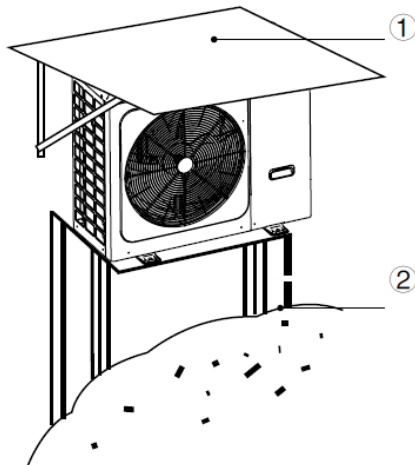

- The use of the condensate drain pipe is not mandatory. If this use is essential, use the elbow supplied and connect a condensate drain.
- Plan for a gravity flow of condensates (wastewater, rainwater, gravel bed).
- If the installation is carried out in an area where the temperature may be below 0°C for a long period, fit the exhaust pipe with a trace heater, to prevent it from freezing. The tracing resistor must heat not only the drain pipe but also the bottom of the unit's condensate collection tank.
- Make sure that the outdoor unit is not tilted more than 5°.

4.3. Hydraulic connection

NOTE

The installation of a sanitary loop on the device is prohibited. In the event of failure of the device on an installation with looping, the guarantee does not apply. For more information, contact the after-sales service.

The cold water inlet and the hot water outlet are threaded in 20/27 (3/4").

4.3.1. Cold water connection

Before making the hydraulic connection, check that the network pipes are clean. The installation must be carried out using a safety unit calibrated at 0.7 MPa (7 bar) (not supplied), new, bearing the NF marking (standard NF EN 1487) connected directly to the cold water connection of the water heater.

ATTENTION

No device (shut-off valve, pressure reducer, hose, etc.) must be placed between the safety unit and the cold water tapping of the water heater.

As water may flow from the relief pipe of the pressure limiting device, the relief pipe must be kept in the open air. Whatever the type of installation, it must include a shut-off valve on the cold water supply, upstream of the safety unit.

The discharge of the safety group must be connected to the waste water in free flow, via a siphon. It must be installed in a frost-free environment. The safety unit drain valve must be put into operation regularly (once or twice a month).

The installation must include a pressure reducer if the supply pressure is greater than 0.5 MPa (5 bar). The pressure reducer must be installed at the start of the general distribution (upstream of the safety unit). A pressure of 0.3 to 0.4 MPa (3 to 4 bar) is recommended.

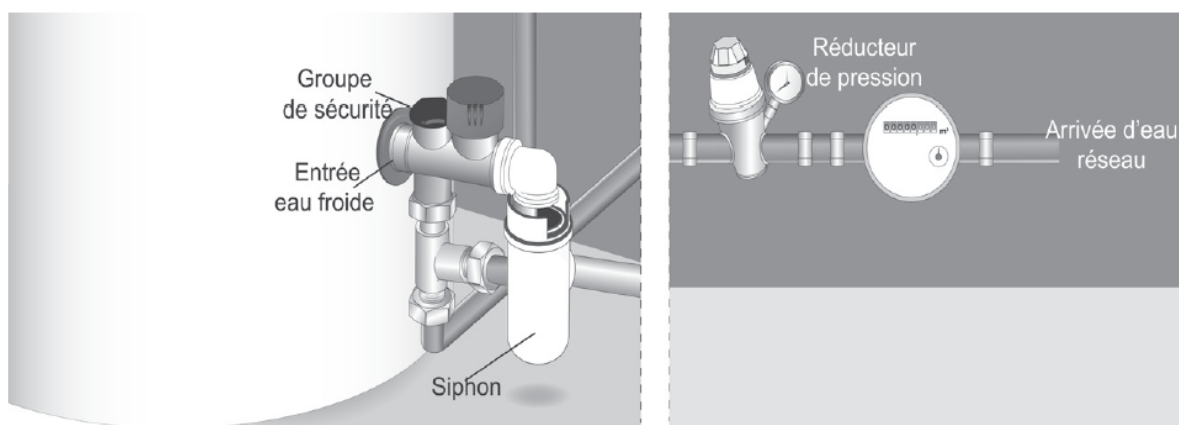

4.3.2. Hot water connection

ATTENTION

Do not connect the hot water connection directly to the copper pipes. It must be equipped with a dielectric connection (supplied with the device).

In the event of corrosion of the threads of the hot water connection not equipped with this protection, our guarantee could not be applied.

WARNING

French regulations impose, in rooms intended for the toilet, a domestic hot water temperature of 50°C maximum at the points of use. In the other rooms, the domestic hot water temperature is limited to 60°C at the draw-off points.

In the case of the use of synthetic material pipes (e.g.: PER, multilayer, etc.), the installation of a thermostatic regulator at the outlet of the water heater is compulsory. It must be adjusted according to the performance of the material used.

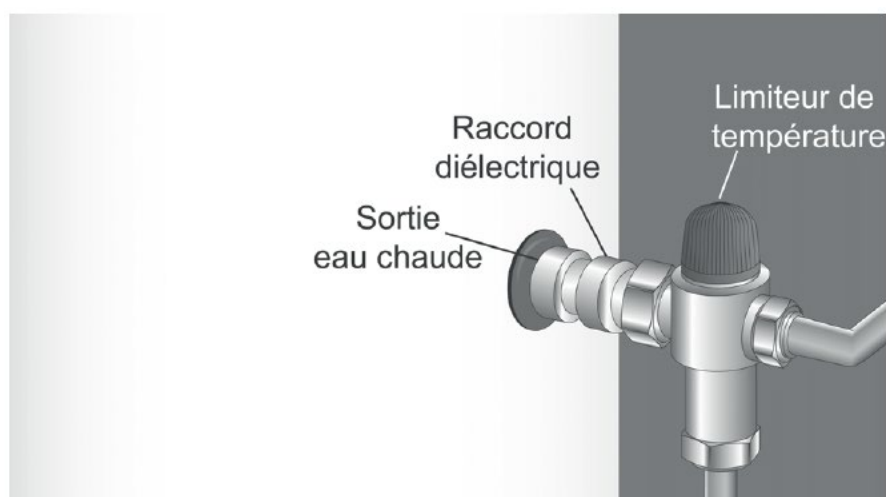

4.3.3. Condensate evacuation

Insert the condensate drain pipe into the condensate drain outlet, located at the rear of the product.

Cut the condensate drain pipe so as not to create a loop on this pipe. Connect the end of the hose to the waste water drain.

4.4. Refrigeration connection

NOTE

The refrigeration connection must be carried out by a qualified professional with a capacity certificate in accordance with Decree 2007/737 and its implementing decrees.

ATTENTION

The refrigeration connections must be thermally insulated in order to avoid any burns and to guarantee optimal performance.

The outdoor unit is pre-charged with R134a for a minimum of 5m and a maximum of 5m. The maximum allowable length is 20m and the maximum height difference between the tank and the outdoor unit is 5m.

Minimum length	5 m
Max length preloaded	5 m
Max elevation	5 m
Max length	30 m
Additional charge	12 g/m

Before connecting the refrigeration connection, fill it with water to check that the installation is leaktight (refer to the chapter "Filling the water heater").

WARNING

The route chosen must be as short and simple as possible, the performance and the life of the system depend on it. The tubes should not have any bends.

- The 2 tubes constituting the refrigeration connection must be insulated separately.

- Use only R134A refrigerant. Mixing with another gas or with air is prohibited.

- Proper evacuation of the installation is essential to ensure proper operation and guarantee the reliability of the system over time.

- Before starting the outdoor unit, check that the 2-way & 3-way valves are open. A closed unit compressor start-up would damage the latter, which cannot then be covered under warranty.

4.4.1. Connecting the refrigeration connections to the outdoor unit

WARNING

The connection between the outdoor unit and the tank will only be made with new copper connections (refrigeration quality), separately insulated.

If the refrigeration connections are exposed to bad weather or UV and the insulation is not resistant to it, it is necessary to provide protection.

The minimum length of the refrigeration connections is 5 m for correct operation.

The guarantee of the device would be excluded in the event of use of the device with refrigeration connections of less than 5 m.

Handle the pipes and pass them through the walls with the protective caps in place.

- Make the flanges after threading the “Flare” nuts.
- After flaring, check the condition of the seat. It must not show any scratches or signs of breaking. Also check dimension “B” (13.2 to 13.5 mm for 3/8” tube and 8.4 to 8.7 mm for 1/4” tube).
- Tighten the nut with the torque wrench to the following torques: 19 N.m for 1/4” tubes and 40 N.m for 3/8” tubes.
- Once the connections have been made, it is necessary to carry out a tightness check of the connection by pressurizing with nitrogen, at 0.35 MPa (35 bar).

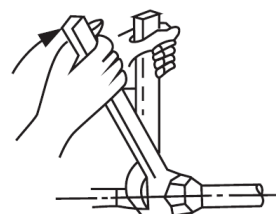
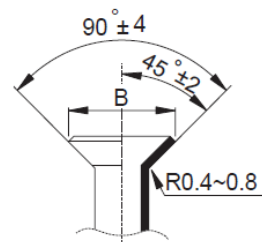

4.4.2. Vacuum test

- Remove the protective caps from the charging ports (Schrader). Connect the blue hose (side equipped with a valve tappet in good condition) of your set of pressure gauges above. Connect a yellow hose with a valve to a vacuum pump fitted with a vacuum gauge and open the blue valve on your set of pressure gauges.
- Switch on the vacuum pump and open the yellow hose valve until the residual pressure in the circuit falls below 0.01 bar. Let the pump run for another 20 minutes after the vacuum has been obtained.
- Close the blue valve on your set of pressure gauges (manifold) and the yellow hose valve, then stop the vacuum pump without disconnecting any of the hoses in place.
- If after 10 minutes the pressure rises, look for the leak, rectify the seal then start again. A circuit is considered tight if the pressure read on the vacuum gauge remains stable for 10 minutes.

WARNING

**The vacuum of the connections is MANDATORY.
Purging by flushing is prohibited.**

4.4.3. Filling

For refrigeration connections longer than 5 meters, an additional charge is necessary. Carry out the additional charge before opening the valves. Refer to the “Additional charge” paragraph.

- Remove the valve control access caps (2 & 3-way valves on the outdoor unit) and open them fully (anti-clockwise, without excessively forcing the stop) starting with the 2-way valve .
- In order to drain the fluid hoses, make the hydraulic and electrical connections. In the product control panel, go to setting mode > Test. Gradually close the 2-way valve in order to reach a pressure close to 0, quickly disconnect the blue hose in operation. If the installation cannot be connected electrically and hydraulically during commissioning, use a blue hose with a valve so as not to purge the fluid present in the hoses and in the manifold. Proceed in this way with its recovery via a fluid transfer unit.
- Completely open the 2-way valve.
- Refit and tighten to 22 N.m the valve access caps.
- Replace the charging port cap and tighten to 8 N.m.
- Once all the caps have been reassembled and tightened, check all the connections for leaks with a suitable detector for HFCs with an accuracy of at least 5 gr/year.
- If the flares have been made correctly, there should be no leaks. In the event of a leak, repatriate the fluid to the outdoor unit (in accordance with the "repatriation of the fluid" paragraph of the user manual) then redo the leaking connection.

4.4.4. Additional charge

During installation, the outdoor unit is preloaded to operate up to 5m of refrigeration connection. In the event of a greater distance, up to a maximum of 30 m, it is necessary to carry out an additional charge of R134A. This must be carried out by a qualified professional with a certificate of competence.

	12 g of R134A per additional meter					
Total length	5 m	10 m	15 m	20 m	25 m	30 m
Additional load	None	60 g	120 g	180 g	240 g	300 g

The additional charge must be carried out after evacuation and before opening the valves of the outdoor unit.

- Disconnect the vacuum pump (yellow hose) and connect a bottle of R134A in its place in the liquid withdrawal position. Open the cylinder valve.
- Add the necessary charge according to the table above using the valve at the manifold.
- As soon as the value displayed on the scale has decreased by the additional charge value required, close the yellow hose valve then close the bottle.
- Then refer to the rest of the commissioning of the product.
- Record the added load on the equipment register of the machine and on the label of the outdoor unit (box provided for this purpose).

4.5. Electrical connection

WARNING

*The water heater must only be switched on after it has been filled with water.
The water heater must be permanently electrically powered.*

The electrical connection must be carried out by a qualified professional and de-energized. The water heater must be connected to a 230V single-phase 50Hz alternating current network. The electrical connection must comply with the NFC 15-100 installation standards as well as the recommendations in force in the country where the water heater is installed.

The installation must include:

- A 16A omnipolar circuit breaker.
- Protection by a 30mA differential circuit breaker.

DANGER

Never power the heating element directly.

The safety thermostat fitted to the electrical back-up must under no circumstances be repaired. Failure to comply with this clause voids the warranty.

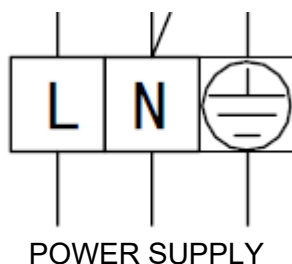

DANGER

Earth connection is mandatory.

4.6. Filling the water heater

1. Open the hot water faucet(s).
2. Open the cold water tap located on the safety unit (ensure that the unit drain valve is in the closed position).
3. After flowing from the hot water taps, close them. The water heater is full of water.
4. Check the tightness of the connection to the pipes and the correct operation of the hydraulic components by opening the drain valve of the safety unit several times, in order to eliminate the presence of any residues in the drain valve.

5. COMMISSIONING

NOTE

During the first commissioning or after a power cut, the heat pump starts after a delay of 3 minutes.

If the heat pump has been tilted, wait 1 hour before





- *Switch on the water heater.*
- *On first power-up, you must set the time (see 6.1 setting the clock).*
- *Then set the other parameters (See 6.2 & 6.3)*
- *When the parameters are set, check the correct operation of the water heater*

5.1. Verification before 1st commissioning

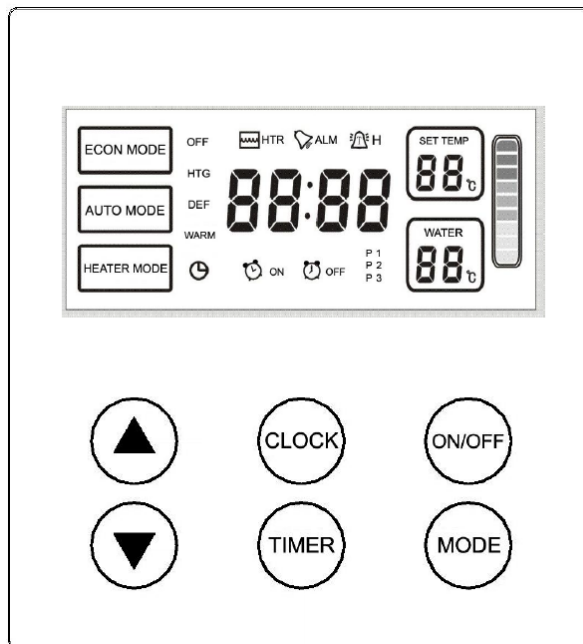
1. Check that the tank is full of water and open the water outlet tap until water flows out.
2. Check that the water pressure is normal (0.15MPa~0.7MPa).
3. Check that the air inlet or outlet is well connected.
4. Check that the power supply voltage is normal, conforms to the requirements of the nameplate.
5. Check whether the equipped parts are well screwed/locked.
6. Check if the wirings are in accordance with the circuit diagram and the ground wire is connected.
7. Check whether the wind inlet and outlet have been cleaned and there is no obstacle.
8. Check that the condensate drain pipe is properly connected and that it is not blocked.
9. After power on, check that the control panel display is normal.

6. CONTROL PANEL



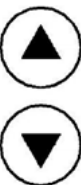

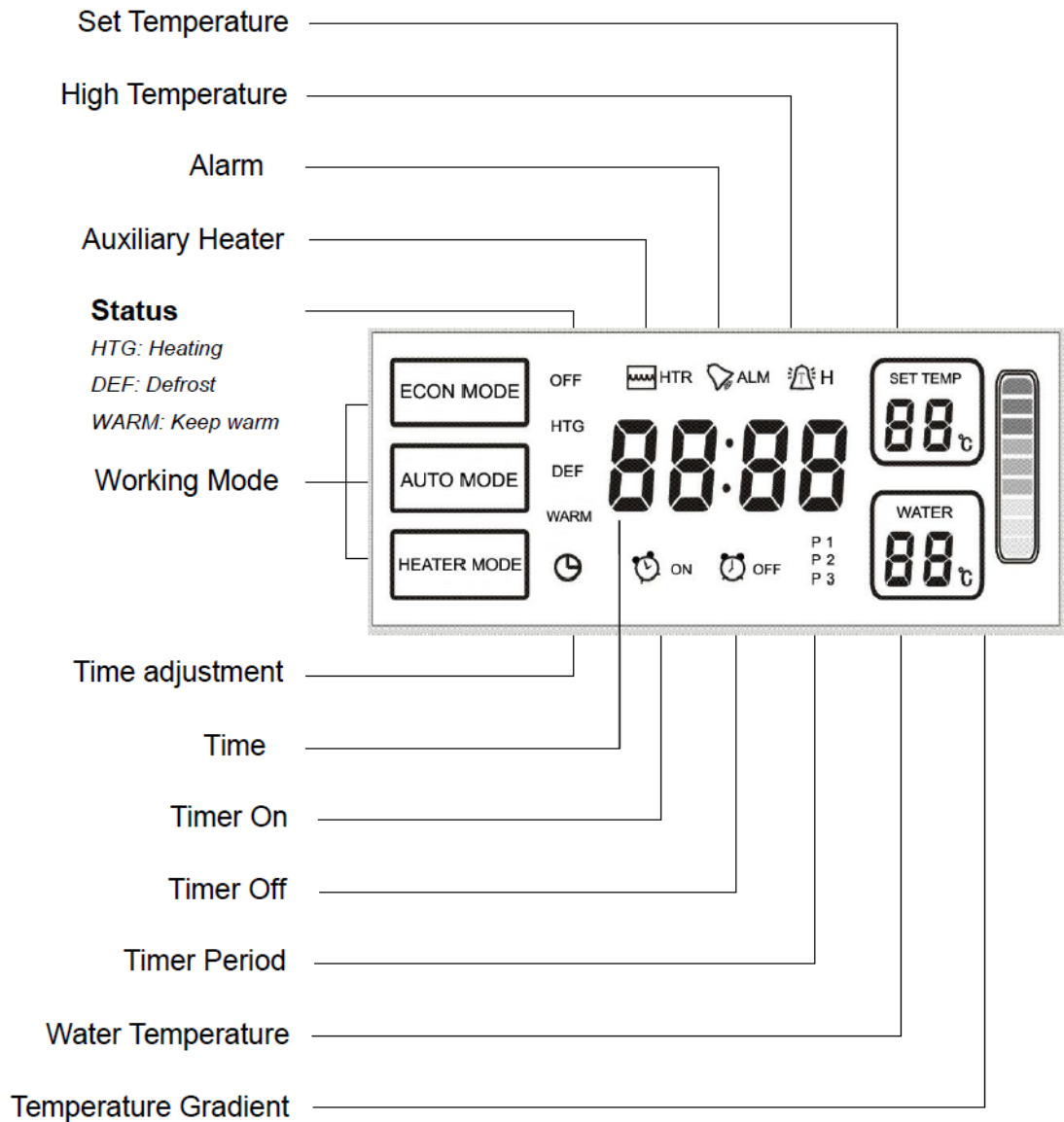
	Turn on / off the water heater
	Change between the different operating modes of the water heater (See 6.2 Operating mode)
	Setting the clock (See 6.1 Setting the clock)
	Setting time schedules (See 6.3 Time schedule)
	Select / Increase / Reduce







The high temperature alarm is on if the water temperature is above 55°C.

6.1. Setting the clock

During the first commissioning, you must set the clock to allow the water heater to regulate properly.

To do this, press the button then  the hours will flash, press to  adjust the time.

Press a second time on to  select the minutes. When the minutes are flashing, press to  adjust the minutes.

 Once the hour and minutes have been set, press one last time  to exit the setting.

6.2. Operating modes

There are 3 different operating modes for the water heater, to change mode, you must push

the button 

6.2.1. ECON MODE

ECON (economical) mode is the only mode where the operating ranges are operational. If you wish to operate your water heater during your off-peak hours, you must use ECON mode and activate the time schedules (See 5.4 Time schedule).

NOTE

This is the most economical mode of operation if you have an off-peak electricity subscription. If you have photovoltaic solar panels, this is also the most economical mode because you can adjust the timer programming to the production hours of your panels.

6.2.2. AUTO MODE

AUTO (automatic) mode allows the water heater to turn on at any time when the tank temperature drops. Time programs are disabled. The water heater turns on and off only according to the temperature of the water in the tank.

6.2.3. HEATER MODE

The HEATER mode (electric heater) authorizes the permanent operation of the electric heater. The water heater turns on and off depending on the temperature inside the tank. Time schedules are disabled.

NOTE



This mode of operation is the least economical. Power consumption will be higher than expected. This operating mode is only to be used when you want a rapid rise in temperature of the tank. (e.g. return from vacation, etc.)

6.3. Time programming



Make sure you are in ECON mode. If you are in another mode see 6.2.

Press the button  to enter the time range setting.

The first range will then flash P1, the alarm clock ON will also flash. You can now set the

hour and minute with  .

Press again  to switch to alarm OFF.

You can now set the hour and minute with 

For the other time slots follow the same principle.

7. ERROR CODES

If an error occurs, a sound will be heard. The message “Alarm” appears on the screen.

The error code appears instead of the temperature alternately.

Some alarms may disappear automatically.



Error codes	Detail	Causes	Solutions
A1	Water temperature sensor	The water temperature sensor is damaged or incorrectly connected	-Reconnect the probe -Change the probe
A2	Condenser temperature sensor	The condenser temperature sensor is damaged or incorrectly connected	-Reconnect the probe -Change the probe
A3	Discharge air temperature sensor	The discharge air temperature sensor is damaged or incorrectly connected	-Reconnect the probe -Change the probe
A4	Room temperature sensor	The room temperature sensor is damaged or incorrectly connected	-Reconnect the probe -Change the probe
A5	High pressure	-High pressure protection -Ambient temperature too high or dirty heat exchanger	-Check and/or change the high pressure sensor -Check the ambient temperature -Clean the exchanger
A6	Electric heater overheating	-Electric heater high temperature protection -Boiler water too hot	-Check the temperature of the balloon -Change the electric heater
A7	Compressor discharge temperature	-Lack of refrigerant -Presence of air in the circuit -Lack of oil in the compressor	-Top up refrigerant -Replace the vacuum and fill with refrigerant -Change compressor oil
A8	Condensate overflow	-Clogged condensate drain pipe -Clogged condensate drain hole	-Check that the pipes are not clogged -Check that the hole is not blocked
A9	Compressor suction temperature sensor	The compressor suction temperature sensor is damaged or incorrectly connected	-Reconnect the probe -Change the probe
--	Display does not turn on or malfunctions	-Power supply problem -Communication cable between the display and the electronic card damaged or incorrectly connected	-Check power supply and voltage -Reconnected the communication cable -Change display -Change the electronic card

8. OPERATING PARAMETERS

WARNING

Modification of the water heater's operating parameters is reserved for qualified personnel. Changing these parameters is likely to affect the performance and correct operation of the water heater.

To enter the parameters of the water heater, it is necessary to press the button  for 5 seconds.

Once in parameter mode, you can see the parameter code, press  to  change parameter.

To enter the desired parameter, press you  can then modify the parameter value

by pressing  .

To exit the  parameter,  press again .

	Code	Detail	Range	Factory setting	Unit	Notes
Temperatures setting	F11	Maximum target temperature	5 – 75	55	°C	Sets the maximum temperature that can be set on the control panel.
	F12	Temperature difference	1 – 30	5	°C	Delta T before restarting the heat pump.
	F13	HP minimum ambient temperature	-10 – 5	-7	°C	Minimum ambient temperature for heat pump operation.
	F14	Maximum heat pump water temperature	20 – 75	55	°C	Maximum water temperature for operation of the heat pump.
	F15	Activation of the electric heater	0 – 1	1	-	Authorize the activation of the electric heater. (0 = No / 1 = Yes)
	F16	Ambient temperature for EH	-10 – 20	0	°C	Ambient temperature below which the electric heater is activated.
	F17	Activation of the EH during the AL cycle	0 – 1	1	-	Allow the activation of the electric heater during the anti-legionella cycle. (0 = No / 1 = Yes)
	F18	Anti-legionella cycle	1 – 990	336	Hour	Time between 2 anti-legionella cycles.
	F19	Water temperature sensor hysteresis	-5 – 5	0	°C	Temperature reading compensation.
Compressor	F21	Startup delays	0 – 10	3	Minute	Compressor start delays.
	F28	Activation of EH in ECON mode	0 – 1	1	-	Allows operation of the electric heater in ECON mode. (0 = No / 1 = Yes)
	F29	Activation of the heat pump in HEATER mode	0 – 1	1	-	Authorizes operation of the heat pump in HEATER mode. (0 = No / 1 = Yes)
Defrost	F31	Defrost activation temperature	-20 – 20	-2	°C	Condenser temperature for start of defrost cycle.
	F32	Defrost stop temperature	0 – 50	25	°C	Condenser temperature for defrost stop.
	F33	Time before defrost	1 – 999	30	Minute	Minimum operating time before defrosting.
	F34	Maximum defrost duration	Off, 1 – 99	5	Minute	Maximum defrost duration
Alarm	F50	Reserve				Reserve
	F51	Reserve				Reserve
	F52	Reserve				Reserve
	F54	Reserve				Reserve
	F55	Reserve				Reserve
	F56	Reserve				Reserve
	F57	Reserve				Reserve
	F58	Reserve				Reserve
F59	Reserve				Reserve	

	Code	Detail	Range	Factory setting	Unit	Notes
Function	F61	Power failure memoryt	Yes/No	Yes	-	Auto restart after power failure.
	F69	Reserve				Reserve
Expansion valve (EEV)	F70	Reserve				Reserve
	F71	Reserve				Reserve
	F72	EEV manual opening	100 – 480	350		
	F73	Reserve				Reserve
	F74	Reserve				Reserve
	F79	Reserve				Reserve
System	F80	Password	OFF 0001 – 9999	4321		OFF = no password 0000 = to clear password
	F85	Reserve				Reserve
Test	F98	Test mode (cold)	Adf			Fan, EEV and compressor start. Press any button to stop. Otherwise stop after 20 minutes.

9. SERVICE

The water heater inlet filter should be cleaned once every 3 months. At the same time, every six months, we suggest draining all storage water and repeatedly washing 2-3 times to remove dirt and sediment.

To keep the unit in good performance, clean the air inlet/outlet filter net once a month, or clean the heat exchanger. Be careful not to damage the copper tubes.

Clean the electric heater every 6 months. Disconnect the power supply before cleaning it.

Check the magnesium anode every 6 months for better anti-corrosion and anti-limescale. Depending on the water quality, change the anode when it runs out.

10. WATER QUALITY

The quality of the water must meet the standards of European Directive 98/83 CE and the criteria defined in the UNE 112.076 standard. Water quality should be tested before use; to evaluate criteria such as concentration, pH value, conductivity, chloride ion concentration (Cl^-), sulfide ion concentration (S_2^-), etc. Some of the chemical ingredient parameters are shown in the following table:

Paramètres	Valeur	Unité	Paramètres	Valeur	Unité
PH	6.5 to 8.5		Oxygen content	<0.1	ppm
SO_4^-	<100		Sand	10 mg/L 0.1 to 0.7mm max diameter	
$\text{HCO}_3^- / \text{SO}_4^-$	>1		Ferrite hydroxide Fe_3O_4 (black)	Dose < 7.5 mg/L 50% of mass with diameter < 10 μm	
Total Hardness	8 to 15	°f	Iron oxide Fe_2O_3 (red)	Dose < 7.5mg/L Diameter < 1 μm	
Cl^-	<50	ppm	Mn^{++}	<0.05	ppm
PO_4^{3-}	<2	ppm	CO_2	<50	ppm
NH_3	<0.5	ppm	H_2S	<50	ppm
Free Chlorine	<0.5	ppm	Temperature	<65	°C
Fe_3^+	<0.5	ppm			



GROUPE AIRWELL
10 RUE DU FORT DE SAINT CYR
78180 MONTIGNY LE BRETONNEUX
FRANCE
www.airwell.com