



Service Manual

FDLK - YDAK

Low temperature floor & ceiling

EN



CONTENT

Part1. General Information.....	1
1 Model Names of Indoor/Outdoor Units.....	2
2 External Appearance.....	3
2 Features.....	5
Part2. Indoor Unit.....	6
Floor & Ceiling.....	6
1 Features.....	7
2 Specifications.....	10
3 Dimensions.....	12
4 Service Space.....	13
5 Wiring Diagrams.....	14
6 Capacity Table.....	15
7 Electric Characteristics.....	18
8 Exploded View.....	19
9 Accessories.....	21
10 The Specification of Power.....	22
11 Field Wiring.....	23
12 Troubleshooting.....	24
Part 3 Outdoor Units.....	26
1 Specification.....	27
2 Dimensions.....	29
3 Service Space.....	29
4 Wiring Diagrams.....	30
5 Electric Characteristics.....	32
6 Operation Limits.....	33
7 Sound Levels.....	34
8 Exploded View.....	35
9 Troubleshooting.....	39
Part 4 Installation.....	42
1 Precaution on Installation.....	43
2 Vacuum Dry and Leakage Checking.....	44
3 Additional Refrigerant Charge.....	46
4 Water Drainage.....	47
5 Insulation Work.....	50
6 Test Operation.....	52
Part 5 Controller.....	53
1 Wired Controller.....	54

R32 50Hz Floor ceiling series

Part1. General Information

1.Model Names of Indoor/Outdoor Units.....	2
2.External Appearance.....	3
3.Features.....	5

1. Model Names of Indoor/Outdoor Units

1.1 Indoor Units

Model name	Dimension (W×H×D) (mm)	Net/Gross weight(kg)	Power supply
FDLK-050N-09M25	1050×675×235	26.5/31	220~240V-1Ph-50Hz
FDLK-070N-09M25	1050×675×235	26.5/31	220~240V-1Ph-50Hz

1.2 Outdoor Units

Model name	Dimension (W×H×D) (mm)	Net/Gross weight(kg)	Power supply
YDAK-050R-09M25	880×555×345	32.5/35	220~240V-1Ph-50Hz
YDAK-070R-09M25	935×702×382	48.7/52.6	220~240V-1Ph-50Hz

2. External Appearance

2.1 Indoor unit

Floor & Ceiling



2.2 Outdoor unit

YDAK-050R-09M25

YDAK-070R-09M25



3. Features

- 4.1 Wide operation range, -15 for cooling and -15 for heating.
- 4.2 Excellent in efficiency, SCOP higher than 4.0, meet the EU's new energy efficiency standards.
- 4.3 High quality coils
 - The coil is constructed of advanced inner grooved copper tube and aluminum fins.
- 4.4 Low operation sound level: Well-known stable and quiet running DC fan motor.
- 4.5 Well-known compressor, GMCC and Mitsubishi.
- 4.6 Universal design: convenient for market stock and spare parts stock.
- 4.8 R32 is environment friendly refrigerant.
- 4.9 CE certification, ROHS certification.

Part2. Indoor Unit

Floor & Ceiling

1.Features.....	7
2.Specifications.....	10
3.Dimensions.....	12
4.Service Space.....	13
5.Wiring Diagrams.....	14
6.Capacity Table.....	15
7.Electric Characteristics.....	18
8. Exploded View.....	19
9.Accessories.....	21
10.The Specification of Power.....	22
11.Field Wiring.....	23
12.Troubleshooting.....	24

1 Features

1. Flexible installation, ceiling suspended and floor standing.



2. Adopting centrifugal fans, higher ESP and longer air flow distance.



3. Two way auto-swing function, built-in two louver step motors, vertical and horizontal air-flow adjustment.



4. Washable air filter, vertical and horizontal grille for option.



5. Digital tube display standard.



6. High efficiency DC fan motor, low noise and more comfortable.

7. New upper and lower buckle type wheel case, the upper plastic wheel case can be removed alone, which is convenient adjust the wheel motor.



8. Water pump optional, pumping head is up to 700mm.

9. Adopting waterproof plastic film on water collector, avoiding water leakage.



10. Self-diagnostic function and multi protection; Auto-restart function.



11. Standard for wireless controller.



2 Specifications

Model			FDLK-050N-09M25	FDLK-070N-09M25
Indoor power supply		V/Ph/Hz	220~240/1/50	220~240/1/50
Cooling	Capacity	KW	2.0-5.3-5.6	2.9-7.0-8.0
	SEER		6.1	6.1
	Energy efficiency class		A++	A++
	Year Consumption	kWh/annum	325	433
Heating	Capacity	KW	2.2-5.3-5.8	3.3-7.7-8.5
	SCOP		4.0	4.0
	Energy efficiency class		A+	A+
	Year Consumption	kWh/annum	1800	2536
Indoor unit power input		W	75	75
Indoor unit current input		A	0.3	0.3
Pdesignc		W	5300	7000
pdesignh(A)		W	4000	6000
Indoor fan motor	Power output	W	75	75
	Capacitor	μF	-	-
	Speed	r/min	1225/1080/930	1225/1080/930
	Insulation class			E
Indoor coil	Number of rows		2	3
	Tube pitch(a)x row pitch(b)	mm	21×13.37	21×13.37
	Fin spacing	mm	1.4	1.4
	Fin type		Hydrophilic	Hydrophilic
	Tube outside dia. and type	mm	Φ7	Φ7
			inner grooved	inner grooved
	Coil length x height x width	mm	680x252x26.7	680x252x40.11
Number of circuits			2	4
Indoor air flow(High speed)		m ³ /h	1200	1200
Indoor noise level	power level	dB(A)	48~52	48~52
	pressure level		36/42/47	36/42/47
Indoor unit	Dimension(W*H*D)	Body(mm)	1050×675×235	1050×675×235
	Packing(W*H*D)	Body(mm)	1130×765×330	1130×765×330
	Net/Gross weight	Body(Kg)	26.5/31	26.5/31

Operation temp		°C	16~32	16~32
Ambient temp	cooling	°C	-15 ~ 50	-15~50
	heating	°C	-15~30	-15~30
Application area		m ²	20-35	28-50

Notes:

1. Nominal cooling capacities are based on the following conditions:
Indoor temp: 27°CDB, 19°CWB; Outdoor temp: 35°CDB; Equivalent ref. Piping: 5m (horizontal)
2. Nominal heating capacities are based on the following conditions:
Indoor temp: 20°CDB; Outdoor temp: 7°CDB, 6°CWB; Equivalent ref. Piping: 5m (horizontal)
3. Actual noise level may differ, depending on the room structure, etc, since these noise values are from an anechoic room.

3 Dimensions

FDLK-050N-09M25 - FDLK-070N-09M25

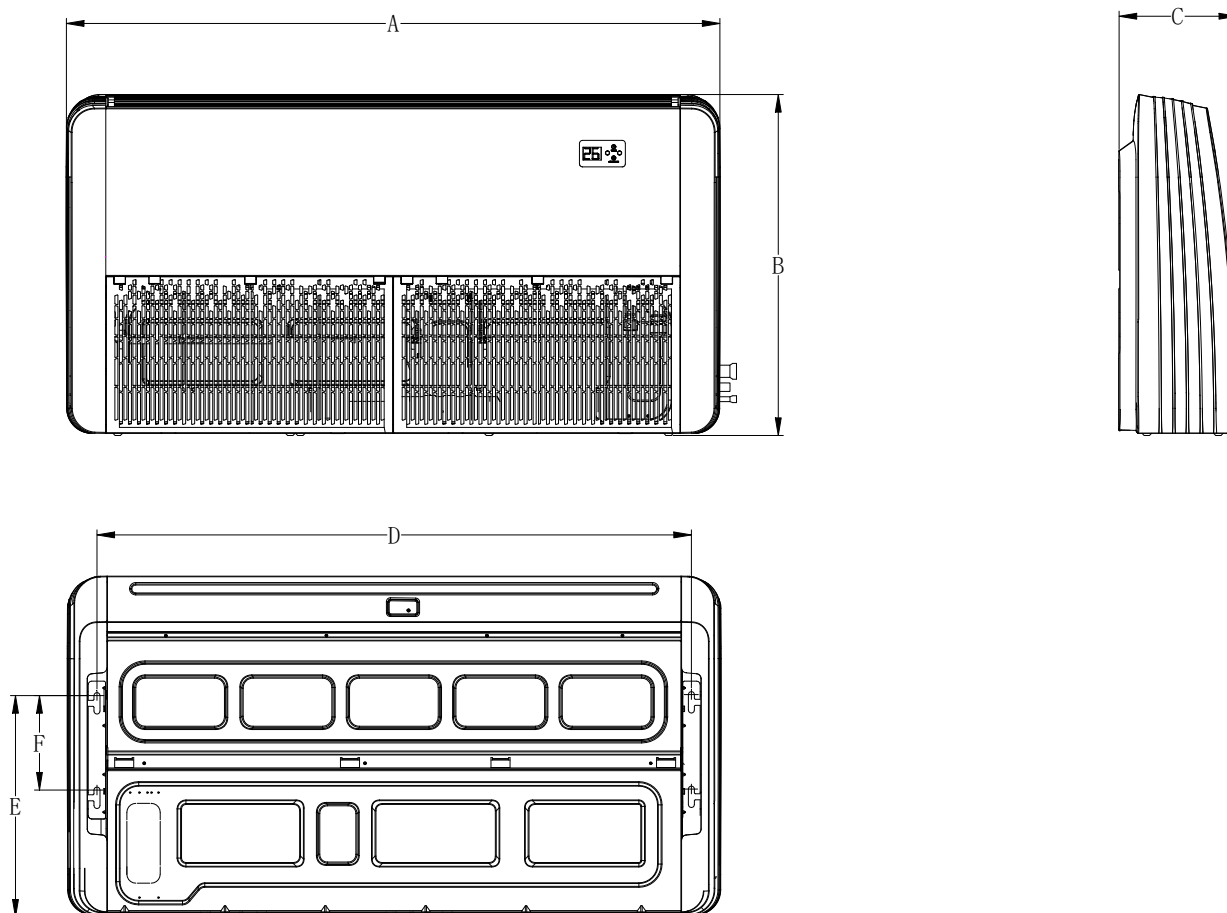

A (mm)	B (mm)	C (mm)	D (mm)	E (mm)	F (mm)
1050	675	235	933	440	188

4 Service Space

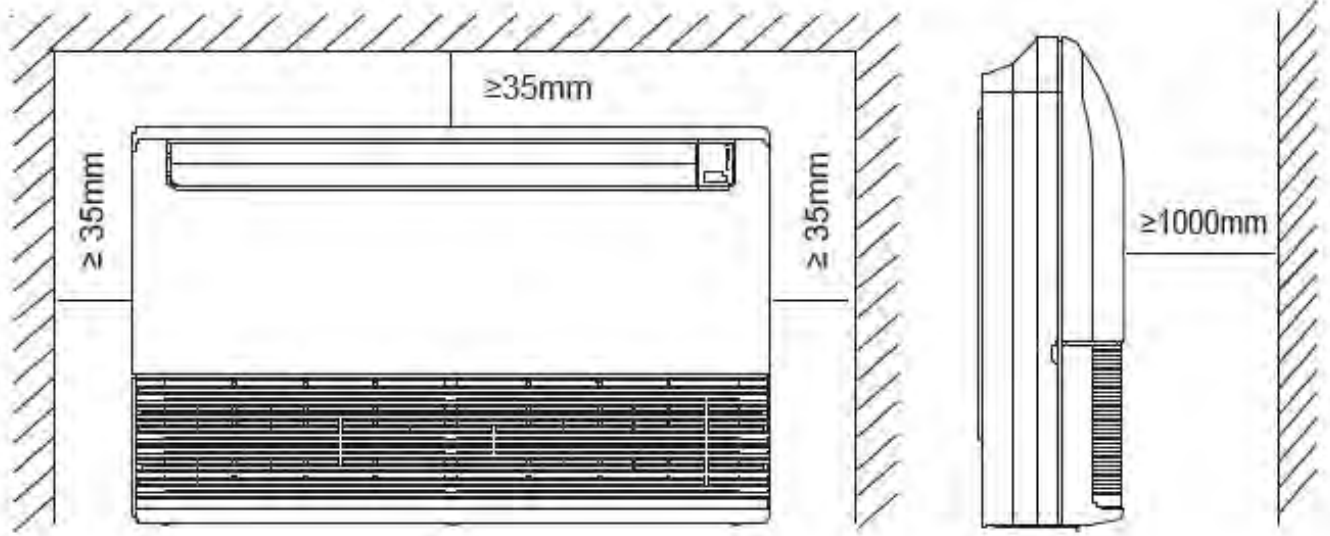

6. Capacity Table

Cooling

6.1 FDLK-050N-09M25

MODEL		FDLK-050N-09M25						
COOLING		OUTDOOR TEMPERATURE DRY						
Indoor Conditions		21°C	25°C	30°C	35°C	40°C	45°C	49°C
21°C D	Total capacity kW	5.09	5.06	5.03	4.99	4.95	4.91	4.88
15°C W	Input kW.	1.42	1.43	1.45	1.46	1.51	1.56	1.61
24°C D	Total capacity kW	5.25	5.22	5.18	5.15	5.10	5.06	5.03
17°C W	Input kW.	1.44	1.45	1.46	1.48	1.54	1.58	1.63
27°C D	Total capacity kW	5.41	5.38	5.34	5.30	5.26	5.22	5.18
19°C W	Input kW.	1.45	1.46	1.48	1.50	1.55	1.61	1.65
29°C D	Total capacity kW	5.48	5.44	5.40	5.36	5.32	5.28	5.24
21°C W	Input kW.	1.47	1.49	1.51	1.53	1.57	1.63	1.67
32°C D	Total capacity kW	5.58	5.55	5.51	5.47	5.42	5.38	5.34
23°C W	Input kW.	1.48	1.49	1.51	1.53	1.58	1.64	1.69

Modèle		FDLK-050N-09M25						
Cooling		Outdoor Temperature Dry						
Indoor conditions		21°C	25°C	30°C	35°C	40°C	45°C	49°C
12°C D	Capacité Total kW	4,48	4,45	4,42	4,39	4,37	4,35	4,32
10°C W	Input kW.	1,11	1,12	1,14	1,17	1,18	1,2	1,24
13°C D	Total capacity kW	4,63	4,59	4,55	4,5	4,47	4,44	4,41
11°C W	Input kW.	1,15	1,16	1,18	1,2	1,22	1,25	1,26
14°C D	Total capacity kW	4,78	4,75	4,72	4,68	4,65	4,61	4,57
11.5°C W	Input kW.	1,22	1,24	1,25	1,27	1,3	1,32	1,35
15°C D	Total capacity kW	4,89	4,86	4,81	4,76	4,72	4,67	4,62
12°C W	Input kW.	1,26	1,27	1,28	1,3	1,33	1,35	1,38
16°C D	Total capacity kW	4,99	4,95	4,92	4,88	4,83	4,81	4,77
12.7°C W	Input kW.	1,28	1,29	1,3	1,32	1,36	1,4	1,43
17°C D	Total capacity kW	5,1	5,06	5,02	4,98	4,94	4,91	4,88
13°C W	Input kW.	1,3	1,32	1,33	1,35	1,4	1,43	1,47
18°C D	Total capacity kW	5,15	5,12	5,08	5,05	5	4,97	4,94
14°C W	Input kW.	1,32	1,34	1,36	1,38	1,42	1,48	1,51
21°C D	Total capacity Kw	5,38	5,35	5,31	5,27	5,23	5,19	5,16
15°C W	Input kW.	1,36	1,37	1,39	1,41	1,46	1,52	1,56
24°C D	Total capacity kW	5,55	5,52	5,47	5,44	5,39	5,35	5,31
17°C W	Input kW.	1,38	1,39	1,41	1,43	1,49	1,54	1,58
27°C D	Total capacity kW	5,72	5,68	5,64	5,6	5,56	5,52	5,47
19°C W	Input kW.	1,4	1,41	1,43	1,45	1,51	1,56	1,6
29°C D	Total capacity kW	5,79	5,75	5,71	5,66	5,62	5,58	5,54
21°C W	Input kW.	1,42	1,44	1,46	1,48	1,53	1,58	1,63
32°C D	Total capacity kW	5,9	5,86	5,82	5,78	5,73	5,68	5,64
23°C W	Input kW.	1,43	1,44	1,46	1,48	1,54	1,59	1,65

6.2 FDLK-070N-09M25

MODEL		FDLK-070N-09M25						
HEATING		OUTDOOR CONDITIONS						
Indoor Conditions		24°C D 18°C W	15°C D 14°C W	7°C D 6°C W	3°C D 2°C W	-5°C D -6°C W	-7°C D -8°C W	-14°C D -15°C W
15°C	Capacity kW	7.95	7.83	7.81	7.58	7.25	7.14	6.43
	Input kW.	1.95	1.85	1.80	1.78	1.74	1.73	1.64
18°C	Capacity kW	7.9	7.78	7.75	7.53	7.2	7.09	6.39
	Input kW.	1.98	1.89	1.83	1.80	1.77	1.76	1.67
20°C	Capacity kW	7.86	7.73	7.7	7.47	7.15	7.04	6.35
	Input kW.	2.04	1.92	1.86	1.84	1.80	1.78	1.70
22°C	Capacity kW	7.82	7.67	7.65	7.42	7.1	6.99	6.3
	Input kW.	2.08	1.95	1.90	1.87	1.83	1.82	1.73
27°C	Capacity kW	7.73	7.62	7.59	7.37	7.05	6.94	6.26
	Input kW.	2.12	1.99	1.94	1.91	1.87	1.85	1.77

Modèle		FDLK-070N-09M25						
Cooling		Outdoor Temperature Dry						
Indoor conditions		21°C	25°C	30°C	35°C	40°C	45°C	49°C
12°C D 10°C W	Total capacity kW Input kW.	6,29 1,69	6,24 1,71	6,2 1,72	6,15 1,75	6,11 1,79	6,06 1,84	6,01 1,9
13°C D 11°C W	Total capacity kW Input kW.	6,43 1,73	6,38 1,74	6,33 1,75	6,27 1,79	6,22 1,82	6,17 1,86	6,12 1,93
14°C D 11.5°C W	Total capacity kW Input kW.	6,59 1,75	6,53 1,77	6,49 1,8	6,45 1,83	6,41 1,87	6,37 1,92	6,33 1,98
15°C D 12°C W	Total capacity kW Input kW.	6,77 1,77	6,72 1,79	6,57 1,83	6,52 1,88	6,5 1,92	6,43 1,97	6,4 2,03
16°C D 12.7°C W	Total capacity kW Input kW.	6,87 1,85	6,82 1,86	6,76 1,89	6,7 1,94	6,65 1,99	6,58 2,04	6,54 2,09
17°C D 13°C W	Total capacity kW Input kW.	6,99 1,9	6,93 1,91	6,87 1,93	6,8 1,96	6,76 2,03	6,71 2,08	6,66 2,13
18°C D 14°C W	Total capacity kW Input kW.	7,05 1,93	6,99 1,95	6,94 1,97	6,87 2,01	6,81 2,08	6,75 2,15	6,72 2,2
21°C D 15°C W	Total capacity Kw Input kW.	7,21 1,97	7,17 1,98	7,11 2	7,06 2,03	7,01 2,1	6,96 2,18	6,9 2,23
24°C D 17°C W	Total capacity kW Input kW.	7,44 1,98	7,4 2	7,35 2,03	7,28 2,05	7,23 2,13	7,17 2,2	7,13 2,26
27°C D 19°C W	Total capacity kW Input kW.	7,66 2,01	7,62 2,03	7,56 2,05	7,4 2,08	7,34 2,16	7,29 2,23	7,23 2,3
29°C D 21°C W	Total capacity kW Input kW.	7,76 2,04	7,71 2,06	7,65 2,09	7,6 2,12	7,54 2,19	7,47 2,26	7,43 2,34
32°C D 23°C W	Total capacity kW Input kW.	7,91 2,05	7,85 2,07	7,8 2,1	7,74 2,12	7,67 2,2	7,62 2,27	7,57 2,35

Heating

6.3 FDLK-050N-09M25

MODEL		FDLK-050N-09M25						
HEATING		OUTDOOR CONDITIONS						
Indoor Conditions		24°C D 18°C W	15°C D 14°C W	7°C D 6°C W	3°C D 2°C W	-5°C D -6°C W	-7°C D -8°C W	-14°C D -15°C W
15°C	Capacity kW	6.05	6	5.98	5.81	5.55	5.47	4.86
	Input kW.	1.50	1.36	1.33	1.31	1.28	1.27	1.21
18°C	Capacity kW	5.99	5.96	5.94	5.77	5.52	5.43	4.9
	Input kW.	1.53	1.39	1.35	1.33	1.30	1.29	1.23
20°C	Capacity kW	5.96	5.92	5.9	5.73	5.48	5.4	4.86
	Input kW.	1.55	1.41	1.38	1.36	1.33	1.32	1.26
22°C	Capacity kW	5.93	5.88	5.86	5.69	5.44	5.36	4.83
	Input kW.	1.58	1.44	1.40	1.38	1.35	1.34	1.28
27°C	Capacity kW	5.8	5.84	5.82	5.65	5.4	5.32	4.79
	Input kW.	1.61	1.46	1.42	1.40	1.38	1.37	1.30

6.4 FDLK-070N-09M25

MODEL		FDLK-070N-09M25						
HEATING		OUTDOOR CONDITIONS						
Indoor Conditions		24°C D 18°C W	15°C D 14°C W	7°C D 6°C W	3°C D 2°C W	-5°C D -6°C W	-7°C D -8°C W	-14°C D -15°C W
15°C	Capacity kW	7.95	7.83	7.81	7.58	7.25	7.14	6.43
	Input kW.	1.95	1.85	1.80	1.78	1.74	1.73	1.64
18°C	Capacity kW	7.9	7.78	7.75	7.53	7.2	7.09	6.39
	Input kW.	1.98	1.89	1.83	1.80	1.77	1.76	1.67
20°C	Capacity kW	7.86	7.73	7.7	7.47	7.15	7.04	6.35
	Input kW.	2.04	1.92	1.86	1.84	1.80	1.78	1.70
22°C	Capacity kW	7.82	7.67	7.65	7.42	7.1	6.99	6.3
	Input kW.	2.08	1.95	1.90	1.87	1.83	1.82	1.73
27°C	Capacity kW	7.73	7.62	7.59	7.37	7.05	6.94	6.26
	Input kW.	2.12	1.99	1.94	1.91	1.87	1.85	1.77

7 Electric Characteristics

Model	Indoor Units				Indoor Fan Motor
	Hz	Voltage	Min.	Max.	kW
FDLK-050N-09M25	50	220-240V	198	254	0.075
FDLK-070N-09M25	50	220-240V	198	254	0.075

8. Exploded View



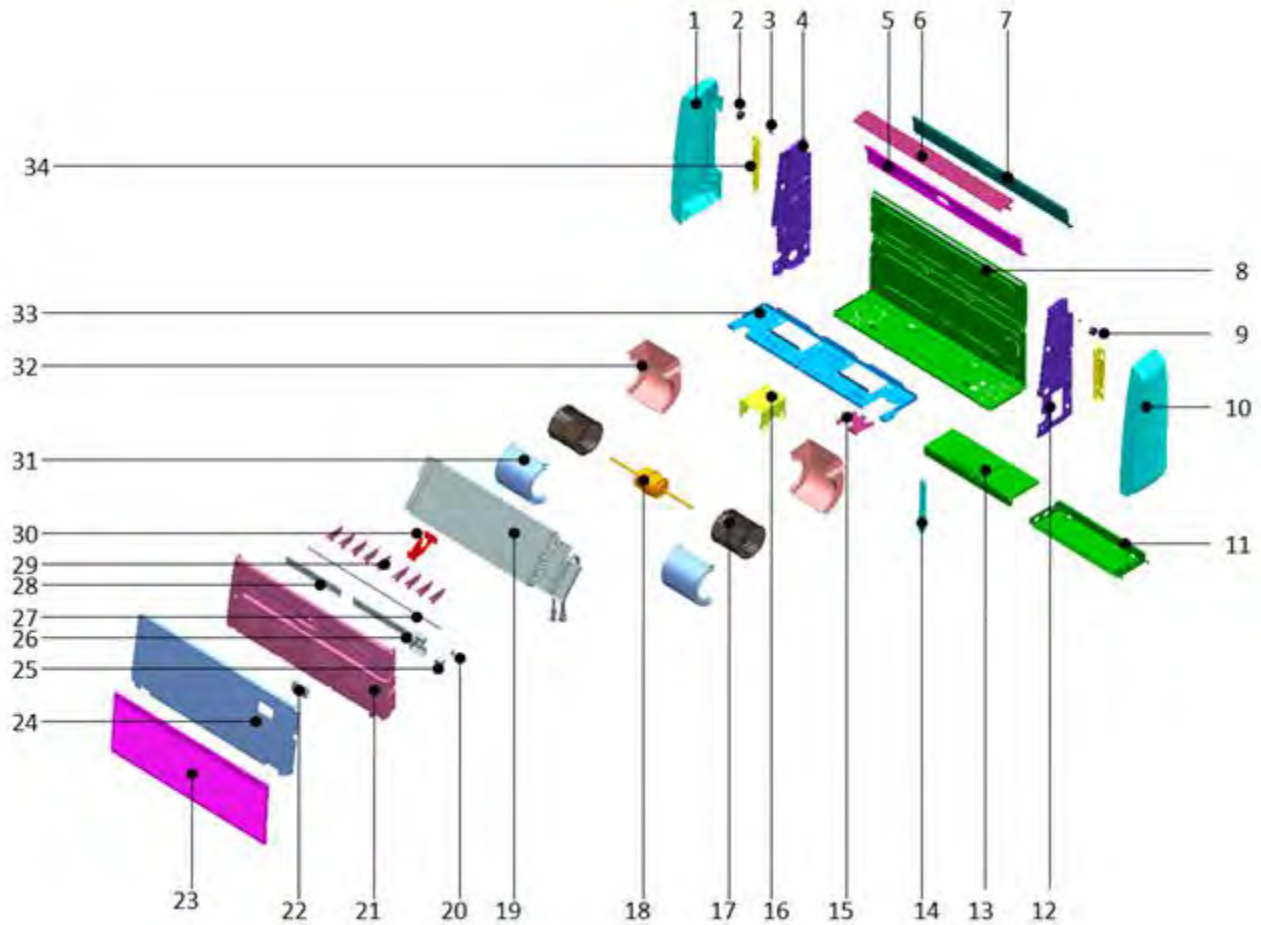



8.1 FDLK-050N-09M25 - FDLK-070N-09M25



No.	Part Name	No.	Part Name
1	Left cover	19.1.2	Evaporator output pipe assembly
2	Stepper motor (horizontal)	19.1.3	Evaporator input pipe assembly
3	Bushing	20	Horizontal swing leaf active rod
4	Left panel assembly	21	Drip tray foam
5	Chassis foam components	22	Display board components
6	Louver assembly	23	Return air grille assembly
7	Rear cover	23.1	Return air grille
8	Chassis components	23.2	Filter
9	Stepper motor	23.3	Grille buckle
10	Right cover	23.4	Grille screw cover
11	Indoor electric control box assembly	24	Top cover assembly
11.1	Indoor main PCB	25	Stepper motor (vertical)
12	Right side panel assembly	26	Louver connecting rod fixing structure 1
13	Electric control box cover	27	Louver connecting rod
14	Support bar	28	Louver connecting rod fixing structure 2
15	Piping plate	29	Wind guide blade
16	Motor bracket	30	Louver bracket
17	Centrifugal fan	31	Upper volute
18	Indoor DC fan motor	32	Lower volute
19	Evaporator components	33	Middle beam welding

19.1	Evaporator pre-welded components	34	Installation lifting ears
19.1.1	Evaporator components	35	Temperature sensor group

9 Accessories

	Name	Shape	Quantity
Installation fittings	1. Hanging arm		2
	2. Wired Remote		1
Controller	3. Remote controller holder (optional)		1
	5. Mounting screw (ST2.9×10-C-H)		2
	6. Alkaline dry batteries (AM4)		2
Others	7. Installation & operation instruction manual		1

10 The Specification of Power

Model		FDLK-050N-09M25	FDLK-070N-09M25
Indoor power supply	V/Ph/Hz	220~240/1/50	
Outdoor power supply	V/Ph/Hz	220~240/1/50	
Power Supply Method		From outdoor unit	
Outdoor unit Power Supply Wire		3×14AWG	3×14AWG
Indoor unit Power Supply Wire		4×16AWG	4×16AWG
Signal wiring		4×1.5	4×1.5

11 Field Wiring

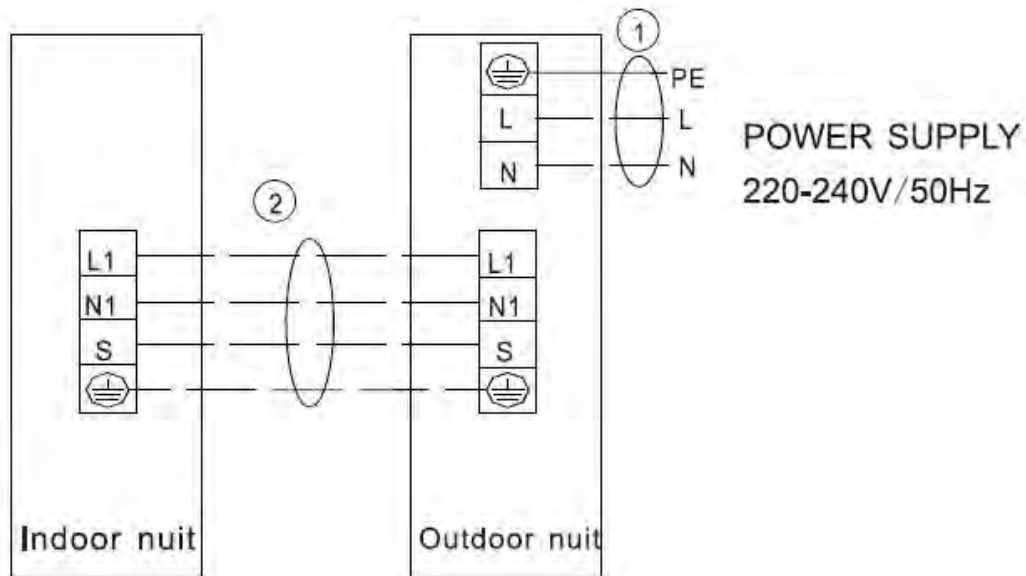

Applies to (220-240V/50Hz) 3.5kW, 5.3kW, 7.1kW

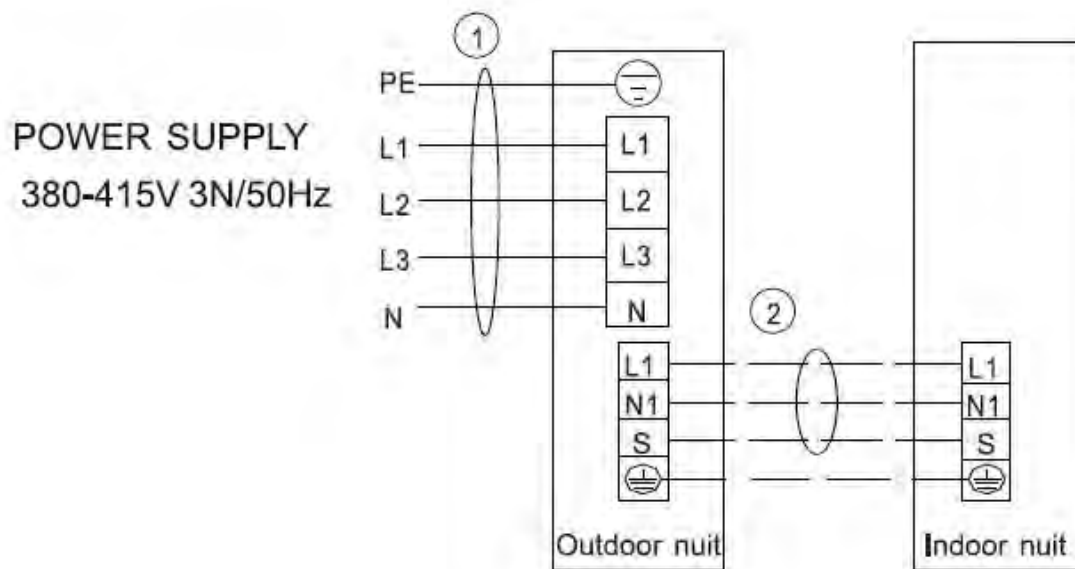

12 Troubleshooting

12.1 Indoor unit (digital display)

LED Display	Display	Error Description
Time light flash	E2	Room temperature T1 sensor error
Defrost, run, protection light flash	E3	Evaporator temperature T2 sensor error
Defrost light flash	E4	Evaporator outlet temperature T2B sensor error
Protection light flash	EE	Water full filled error
Run, defrost light flash	E9	Indoor unit and wired controller communication error
Run, time light flash	E7	Indoor EEPROM error
Defrost, time light flash	E8	Indoor fan motor speed lose protection
Defrost warning lights flash	F4	Outside ambient temperature T4 sensor error
	F5	Discharge temperature T5 sensor error
	P9	Outdoor fan motor protection
	E5	Outdoor unit error
	FE	Outdoor EEPROM error
	F6	Condenser temperature T3 sensor error
	P5	Condenser temperature T3 too high protection
	PA	Anti-typhoon protection
	L1	DC side over-voltage
	PE	DC side over-current
	EF	Mode conflict
	P6	Inverter IPM protection
	H6	3 times P4 protection (Reserved)
	H5	3 times P2 protection (Reserved)
Timing warning lights flash	E1	Communication error between indoor and outdoor unit
Running defrost timing lights flash	P1	High pressure protection
Defrost timing warning lights flash	P2	Low pressure protection
Running timing warning lights flash	P4	Outdoor discharge temperature too high protection
Running defrost timing	E0	Three phase sequence error

12.2 Wired controller

	Description
1	Indoor unit capacity HP
2	Indoor unit capacity demand (Reserved)
3	Indoor unit capacity demand after T4 amendment (Reserved)
4	Indoor unit capacity demand after T2 amendment (Reserved)
5	Room temperature T1 value
6	Middle of evaporator temperature T2 value
7	Outlet of evaporator temperature T2B value
8	Condenser temperature T3 value
9	Ambient temperature T4 value
10	Discharge temperature T5 value (Max 99°C displayed)
11	EXV opening degree
12	Frequency of compressor
13	AC side voltage value/4 (Reserved)

Part 3 Outdoor Units

1.Specifications.....	27
2.Dimensions.....	29
3.Service Space.....	29
4.Wiring Diagrams.....	30
5.Electric Characteristics.....	32
6.Operation Limits.....	33
7.Sound Levels.....	34
8.Exploded View.....	35
9.Troubleshooting.....	39

1 Specifications

Model			YDAK-050R-09M25	YDAK-070R-09M25	
Outdoor power supply		V/Ph/Hz	220~240/1/50	220~240/1/50	
Cooling	Power input	W	300-1495-3220	340-2093-3900	
	Current input	A	1.3-6.5-14	1.5-9.1-17	
Heating	Power input	W	250-1380-3335	305-1863-3500	
	Current input	A	1.1-6.0-14.5	1.3-8.1-15.2	
Max. power input		W	3680	4000	
Max. current input		A	20.0	20.0	
Compressor	Type		DC/Single-rotary	DC/Twin-rotary	
	Frequency range		rps	10-120	10-120
	Capacity		W	4370	7715
	Input		W	1135	2085
	Current(RLA)		A	7.5	9.45
	Refrigerant oil		ml	VG74/440	VG74/670
Indoor fan motor	Power output		W	34	75
	Speed		r/min	860	850
	Insulation class			E	B
Outdoor coil	Number of rows			2	2
	Tube pitch(a)x row pitch(b)		mm	25×21.65	25×21.65
	Fin spacing		mm	1.4	1.4
	Fin type			Hydrophilic	Hydrophilic
	Tube outside dia. and type		mm	9.52	9.52
				inner grooved	inner grooved
	Coil length x height x width		mm	815x500x43.3	777×650×43.3
Number of circuits			2	5	
Outdoor air flow(High speed)		m ³ /h	1950	3200	
Outdoor noise level	power level	dB(A)	66	68	
	pressure level		52	54	
Outdoor unit	Dimension(W*H*D)		mm	880×555×345	935×702×382
	Packing(W*H*D)		mm	920×600×380	975×770×435
	Net/Gross weight		kg	32.5/35	48.7/52.6
Refrigerant type/quantity		g	R32/1200	R32/1450	
Throttle part			EXV	EXV	

	Signal wiring	mm ²	4×1.5	4×1.5
Refrigerant piping	Liquid side/Gas side	mm	Φ6.35/Φ12.7	Φ9.52/Φ15.88
	Max. pipe length	m	15(30)	20(50)
	Max. high drop	m	8(20)	10(25)
Ambient temp.	Cooling	°C	-15~50	-15~50
	Heating	°C	-15~30	-15~30

2 Dimensions

2.1 YDAK-050R-09M25 - YDAK-070R-09M25

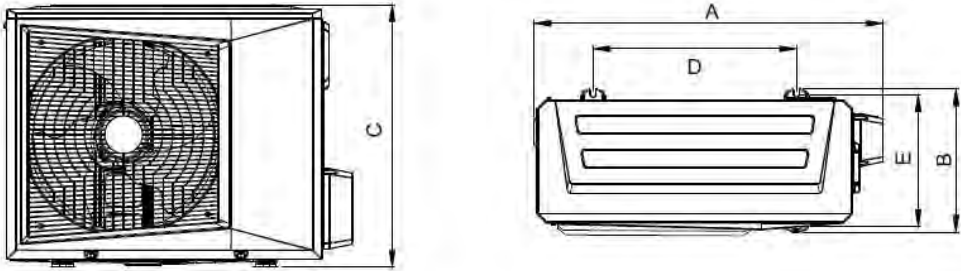

Machine capacity	Project	A	B	C	D	E
18K		880	345	555	508	314
24K		935	382	702	544	353

3 Service Space

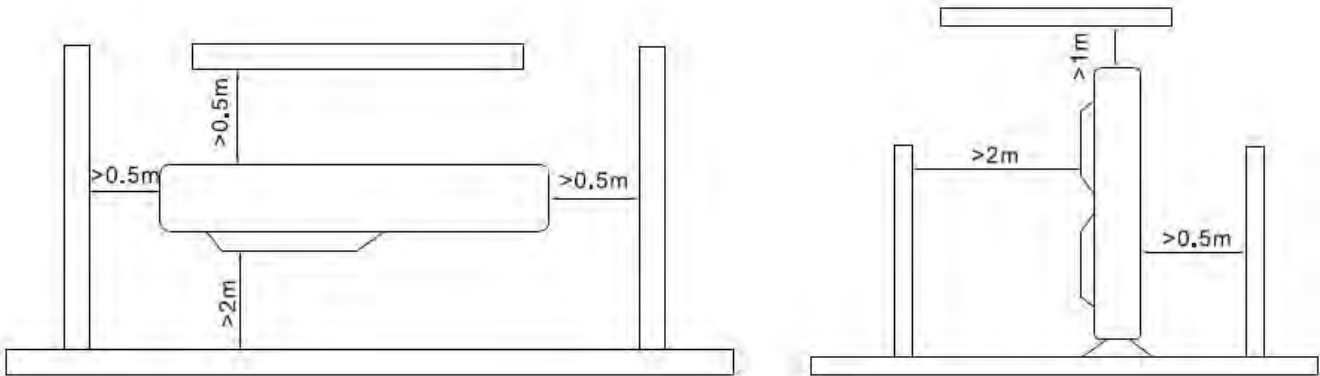

4 Wiring Diagrams

4.1 YDAK-050R-09M25

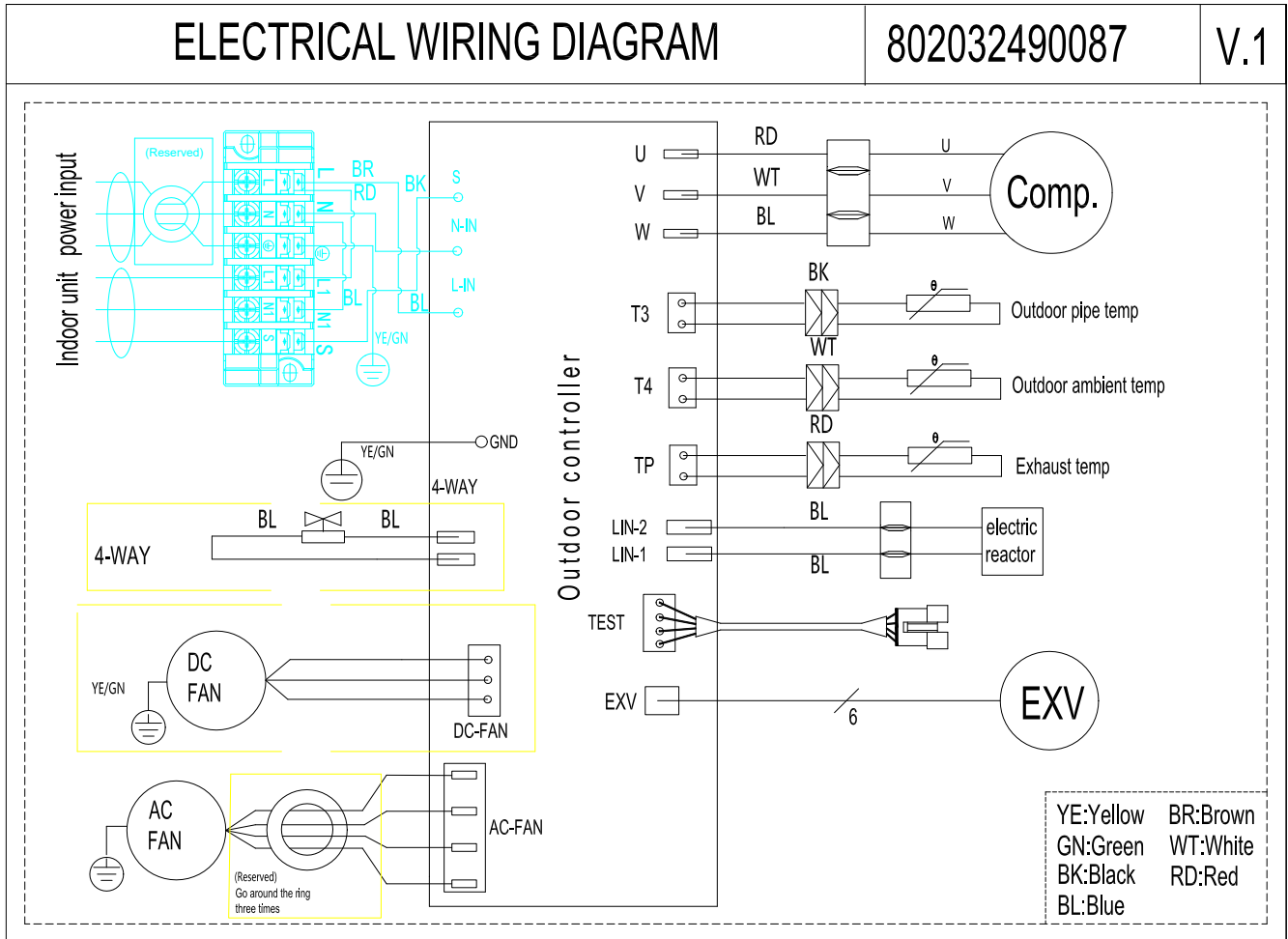

5 Electric Characteristics

Model	Outdoor Unit				
	Hz	Voltage	Min.	Max.	Outdoor motor (kW)
YDAK-050R-09M25	50	220~240V	198	254	0.034
YDAK-070R-09M25	50	220~240V	198	254	0.075

6 Operation Limits

Operation mode	Outdoor temperature(°C)	Room temperature(°C)
Cooling operation	-15~50	16~32
Heating operation	-15~30	16~32

7. Sound Level

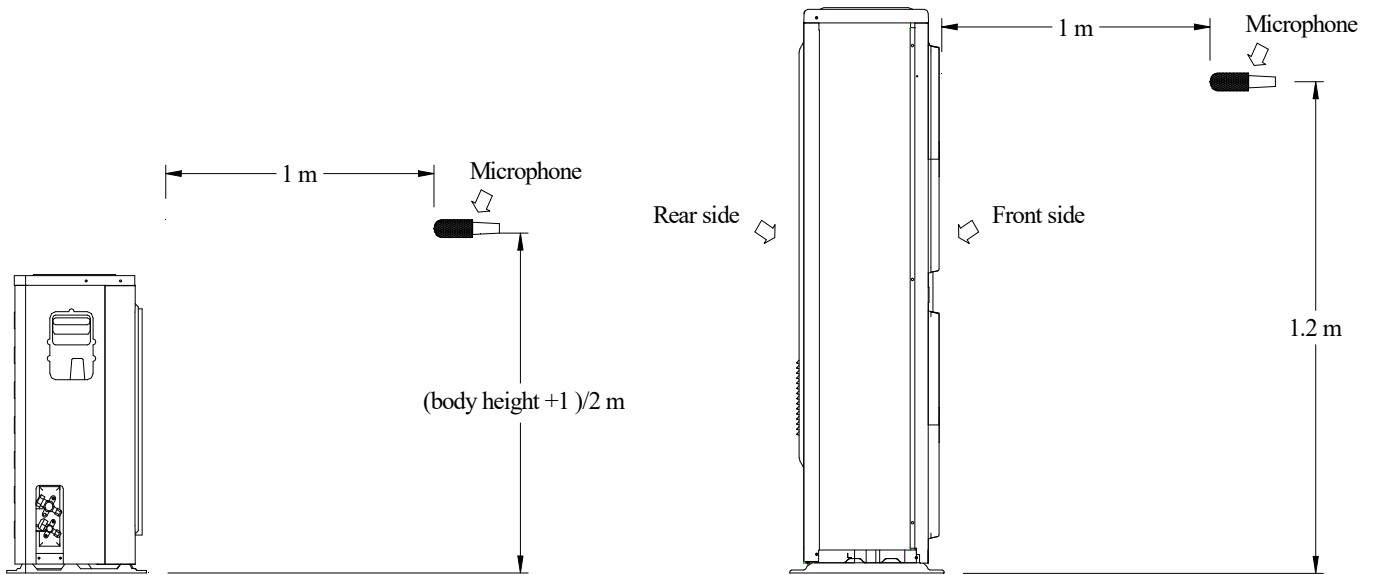

Model	Power level dB(A)	Pressure level
YDAK-050R-09M25	66	52
YDAK-070R-09M25	68	54

Note: Sound level is measured at a point 1 m in front of the unit, at a height of $(\text{Unit body height} + 1) / 2$ m.

8. Exploded Views

8.1 YDAK-050R-09M25

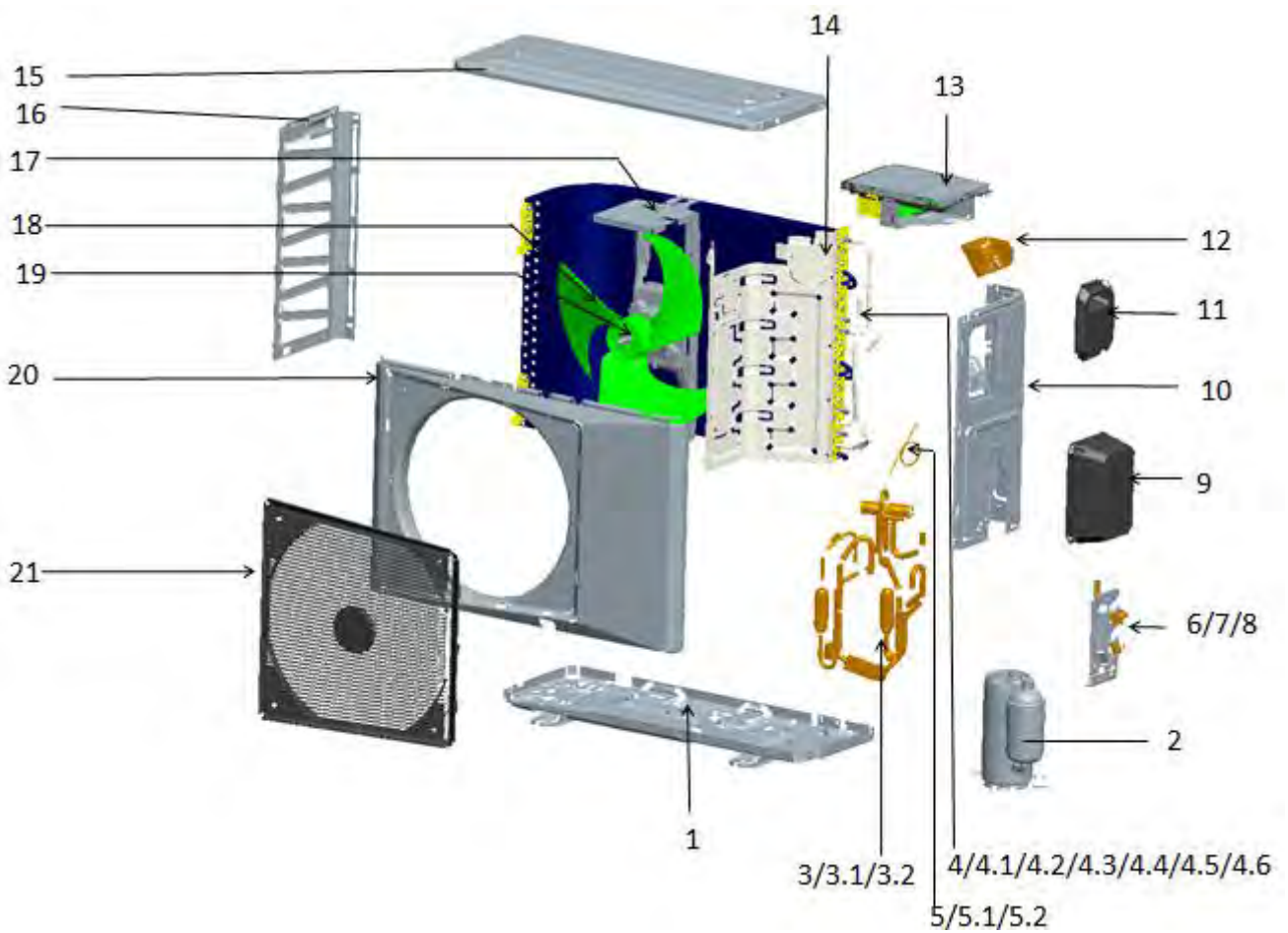

No	Part Name	No	Part Name
1	Outdoor chassis assy	8	Cut-off valve-C-DN10(T)
2	Inverter compressor	9	Stop valve cover
3	4-way valve assy	10	Right clapboard parts
3.1	4-way valve	11	Big handle
3.2	4-way valve coil	12	Electronic control mounting plate
4	Condenser assy	13	Outdoor main PCB
4.1	Condenser	14	Separating board
4.2	Condenser input pipe assembly	15	Top cover parts
4.3	Condenser connection pipe	16	Left clapboard
4.4	L-type tube	17	Motor bracket assembly
4.5	Process channel	18	Axial-flow fan blade
4.6	Probe of copper pipe	19	Outdoor DC fan motor
5	Capillary parts	20	Front panel
5.1	Electronic expansion valve	21	Air outlet net cover (plastic)
5.2	Electronic expansion valve coil	22	Ambient temperature sensor
6	Cut-off valve-C-DN4(T)	23	Condenser temperature sensor
7	Valve holder	24	Discharge temperature sensor

8.2 YDAK-070R-09M25

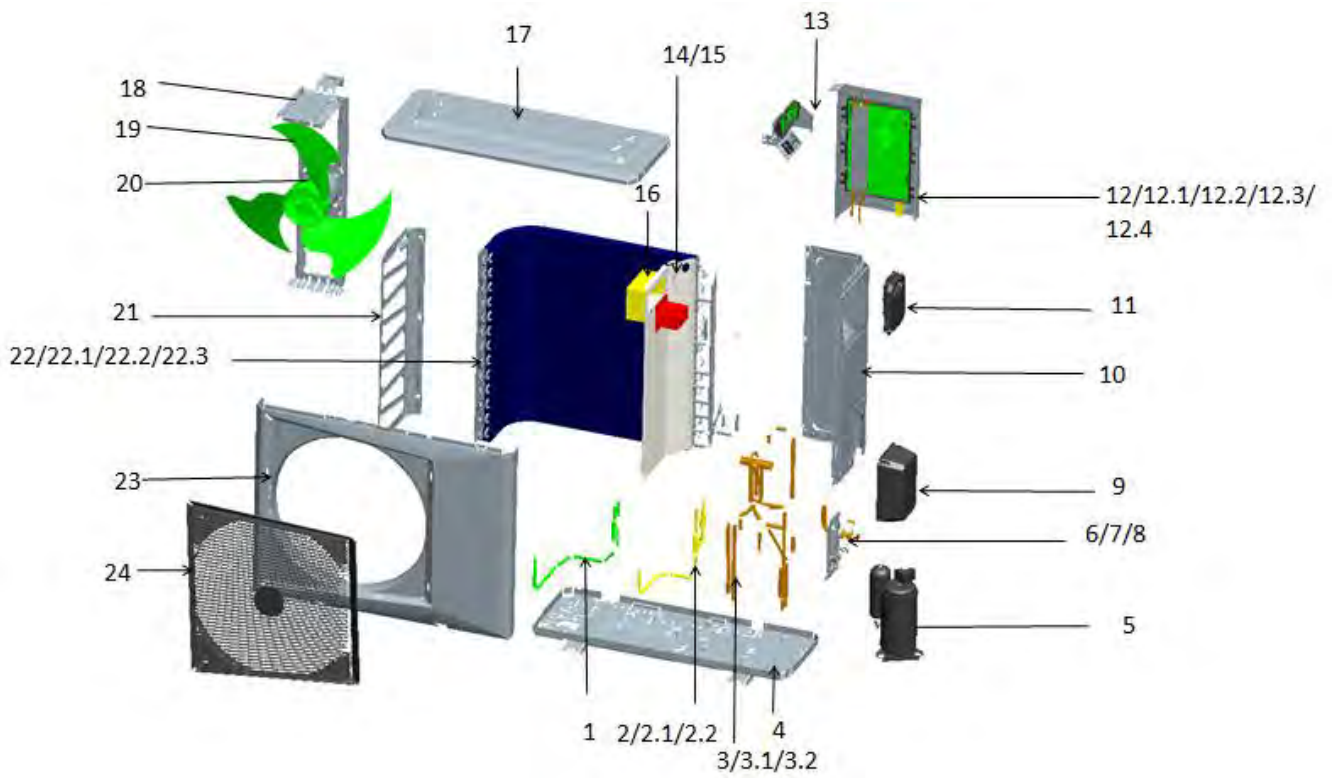
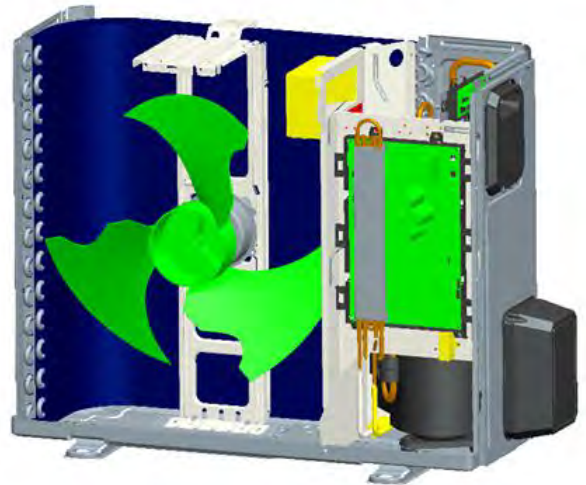

No.	Part Name	No.	Part Name
1	Throttle valve assembly	12.4	Outdoor display board
2	Electronic expansion valve assembly	13	Terminal block mounting plate
2.1	Electronic expansion valve coil	14	Middle separating board
2.2	Electronic expansion valve	15	Reactor
3	4-way valve assy	16	Waterproof cover
3.1	4-way valve	17	Top cover assembly
3.2	4-way valve coil	18	Motor bracket assembly
4	Outdoor chassis assy	19	Axial-flow fan blade
5	Inverter compressor	20	Outdoor DC fan motor
6	Cut-off valve-DN13	21	Left side panel
7	Valve holder	22	Condenser parts
8	Cut-off valve-DN8	22.1	Condenser assembly
9	Stop valve cover	22.2	Gas collecting pipe assembly
10	Right side panel parts	22.3	Shunt component
11	Big handle	23	Front panel components
12	Outdoor electronic control module	24	Plastic grille
12.1	Welded parts of electronic control mounting plate	25	Discharge temperature sensor
12.2	Terminal	26	Condenser temperature sensor
12.3	Outdoor main PCB	27	Ambient temperature sensor

9 Troubleshooting

9.1 YDAK-050R-09M25

Error code display

Error code	Description	Error code	Description
E01	Communication fault between IDU and ODU	P0C	Current protection
E02	Zero cross detection fault of IDU	P1x	Bus voltage protection
E03	stall fault of indoor fan	P21	Low temperature dehumidification fault
E04	T2B (indoor coil outlet temp.) sensor fault	P22	High and low temp. protection of evaporator
E08	Mode conflict	P23	High temp. protection of condenser
E09	ODU EEPROM error	P24	High and low temp. protection of environment
E0E	IDU EEPROM error	P25	High discharge temperature of compressor
E11	IDU T1 (room temperature) sensor fault	P28	Abnormal discharge in commodity inspection mode (compressor reversal)
E12	IDU T2 (indoor coil middle temp.) sensor fault	P29	T3 abnormal in commodity inspection heating mode (System exception, 4-way valve disconnected)
E13	ODU T3 (outdoor coil outlet temp.) sensor fault	P30	High pressure protection
E14	ODU T4 (ambient temp.) sensor fault	P31	Low pressure protection
E15	ODU discharge temp. sensor fault	H1x	Compressor fault
E16	Module temp. sensor fault	H3x	PFC fault
E17	Suction temp. sensor fault	L01	Lower frequency because of voltage limit
E18	TZA sensor fault	L02	Lower frequency because of high or low temp. limit of evaporator
E19	TZB sensor fault	L03	Lower frequency because of high temp. limit of condenser
E2x	Fan motor fault	L05	Lower frequency because of high discharge temp. of compressor
		L06	Lower frequency because of module temperature limit
		L0C	Lower frequency because of current limit

Spot check table

Fr	Running frequency
FT	Target frequency
T1	Unit A T1
T2	Unit A T2
Sr	IDU A fan speed
Tb	IDU A T2B
AL	IDU A EXV opening degree
An	Capacity demand of IDU A
Hn	Amended total capacity demand
b1	Unit B T1
b2	Unit B T2
bb	Unit B T2B
bS	Unit B fan speed
bL	Unit B EXV opening degree
bn	Capacity demand of IDU B
TH	Suction temperature
T3	Outdoor unit pipe temperature
T4	Ambient temperature
TP	Discharge temperature
T6	IPM board temperature
od	Mode
dT	Outdoor load target state
CC	Quantity of IDU
Ud	DC voltage
dL	Current
Pr	Outdoor unit fan speed
Lr	Master EXV opening degree

Notice:

For 18K units, an additional maintenance controller is needed to show error codes and do spot check.

9.2 YDAK-070R-09M25

Error code display

Code	Failure or protection definition	Code	Failure or protection definition
E02	Comm. failure between outdoor unit and indoor unit	P06	IPM modules protection
E04	T4 temperature sensor failure	P07	Anti-freeze protection
E05	T5 temperature sensor failure	P09	Outdoor fan motor stall
E06	T3 temperature sensor failure	P11	Evaporator high temperature protection
E07	Indoor EEPROM failure	L0	DC compressor failure
E09	AC low voltage protection	L01	DC bus low voltage protection
E10	Outdoor EEPROM failure	L02	DC bus high voltage protection
E11	Indoor fan motor failure	L04	MCE fault/ sync/ closed loop
E12	IPM module temperature sensor protection	L05	Zero speed protection
E16	IPM high temperature protection (Ft)	L07	Compressor phase loss protection
E20-E29	Fan motor failure	L08	Compressor stall
H0	Comm. failure between outdoor unit and indoor unit	L0A	Frequency limitation by voltage
H21-36	Compressor failure	L0B	Evaporator limitation by condenser temperature
P01	High pressure protection	L0C	Frequency limitation by condenser temperature
P02	Low pressure protection	L0D	Frequency limitation by discharge temperature
P03	AC/DC over-current protection	L0E	Frequency limitation by IPM module high temperature
P04	Excessive exhaust temperature protection	L0F	Frequency limitation by current
P05	Excessive condenser temperature protection		

Spot check table

No.	Display content	No.	Display content
00	Frequency, the quantity of indoor units, running mode or error code	09	T4 outdoor ambient temperature
		10	T5 exhaust temperature
01	Outdoor power	11	AC current
02	Running mode (0: shutdown; 1: fan; 2: cooling; 3: heating; 4: forced cooling)	12	DC current
		13	AC voltage
03	Indoor capacity demand	14	DC voltage
04	The actual operation capacity of outdoor units	15	The quantity of indoor units
05	The target frequency of compressor	16	The quantity of running indoor units
06	Fan speed state (0-7)	17	The indoor demand
07	T2 average temperature	18	The T1 temperature of indoor
08	T3 condensing temperature	19	Electronic expansion valve opening degree

Part 4 Installation

1. Precaution on Installation.....	43
2. Vacuum Dry and Leakage Checking.....	44
3. Additional Refrigerant Charge.....	46
4. Water Drainage.....	47
5. Insulation Work.....	50
6. Test Operation.....	52

1. Precaution on Installation

1.1. Measure the necessary length of the connecting pipe, and make it by the following way.

- a. Connect the indoor unit at first, then the outdoor unit.

Bend the tubing in proper way. Do not harm them.

CAUTIONS:

- Daub the surfaces of the flare pipe and the joint nuts with frozen oil, and wrench it for 3~4 rounds
- With hands before fasten the flare nuts.

Be sure to use two wrenches simultaneously when you connect or disconnect the pipes.

Pipe gauge	Tightening torque	Flare dimension A		Flare shape
		Min (mm)	Max	
Φ6.4	15~16N.m (153~163 kgf.cm)	8.3	8.7	
Φ9.5	25~26N.m (255~265kgf.cm)	12.0	12.4	
Φ12.7	35~36N.m (357~367kgf.cm)	15.4	15.8	
Φ15.9	45~47N.m (459~480 kgf.cm)	18.6	19.1	
Φ19.1	65~67N.m (663~684kgf.cm)	22.9	23.3	

- b. The stop value of the outdoor unit should be closed absolutely (as original state). Every time you connect it, first loosen the nuts at the part of stop value, then connect the flare pipe immediately (in 5 minutes). If the nuts have been loosened for a long time, dusts and other impurities may enter the pipe system and may cause malfunction later. So please expel the air out of the pipe with refrigerant before connection.
- c. Expel the air after connecting the refrigerant pipe with the indoor unit and the outdoor unit. Then fasten the nuts at the repair-points.

1.2. Locate The Pipe

- a. Drill a hole in the wall (suitable just for the size of the wall conduit), then set on the fittings such as the wall conduit and its cover.
- b. Bind the connecting pipe and the cables together tightly with binding tapes. Do not let air in, which will cause water leakage by condensation.
- c. Pass the bound connecting pipe through the wall conduit from outside. Be careful of the pipe allocation to do no damage to the tubing.

1.3. Connect the pipes.

1.4. Then, open the stem of stop values of the outdoor unit to make the refrigerant pipe connecting the indoor unit with the outdoor unit in fluent flow.

1.5. Be sure of no leakage by checking it with leak detector or soap water.

1.6. Cover the joint of the connecting pipe to the indoor unit with the soundproof / insulating sheath (fittings), and bind it well with the tapes to prevent leakage.

2 Vacuum Dry and Leakage Checking

2.1 Vacuum Dry: use vacuum pump to change the moisture (liquid) into steam (gas) in the pipe and discharge it out of the pipe to make the pipe dry. Under one atmospheric pressure, the boiling point of water(steam temperature) is 100°C. Use vacuum pump to make the pressure in the pipe near vacuum state, the boiling point of water falls relatively. When it falls under outdoor temperature, the moisture in the pipe will be vaporized.

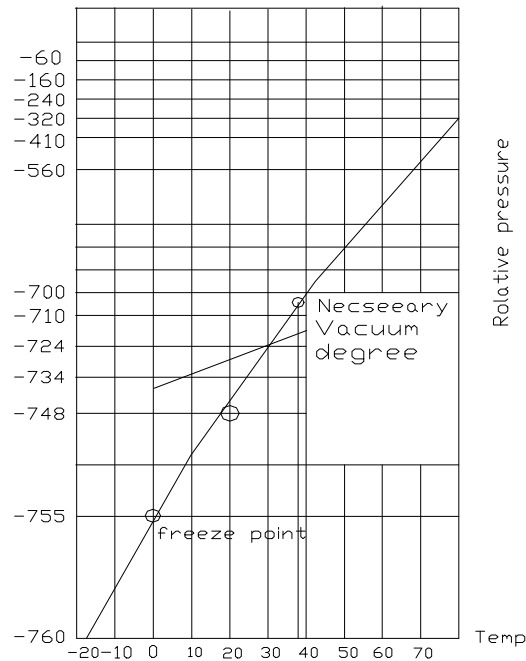

2.2 Vacuum dry procedure

There are two methods of vacuum dry due to different construction environment: common vacuum dry, special vacuum dry.

①. Common vacuum dry procedure

- Vacuum dry (for the first time)---connect the all-purpose detector to the inlet of liquid pipe and gas pipe, and run the vacuum pump more than two hours (the vacuum pump should be below -755mmHg)
- If the pump can't achieve below -755mmHg after pumping 2 hours, moisture or leakage point will still exist in the pipe. At this time, it should be pumped 1 hour more.
- If the pump can't achieve -755mmHg after pumping 3 hours, please check if there are some leakage points.
- Vacuum placement test: place 1 hour when it achieves -755mmHg, pass if the vacuum watch shows no rising. If it rises, it shows there's moisture or leakage point.
- Vacuuming from liquid pipe and gas pipe at the same time.
- Sketch map of common vacuum dry procedure.

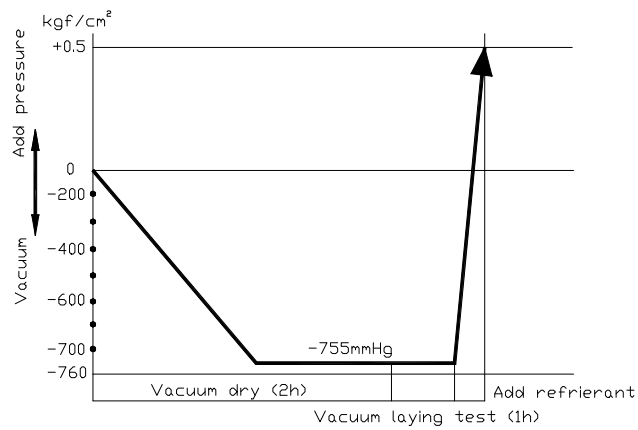

②. Special vacuum dry procedure

- This vacuum dry method is used in the following conditions:
- There's moisture when flushing the refrigerant pipe.
- Rainwater may enter into the pipe.
- Vacuum dry for the first time 2h pumping

③. Vacuum destroy for the second time Fill nitrogen to 0.5Kgf/cm²

Because nitrogen is for drying gas, it has vacuum drying effect during vacuum destroy. But if the moisture is too much, this method can't dry thoroughly. So, please pay more attention to prevent water entering and forming condensation water.

④. Vacuum dry for the second time 1h pumping

Determinant: Pass if achieving below -755mmHg. If -755mmHg can't be achieved in 2h, repeat procedure

③ and ④.

⑤. Vacuum placing test 1h

⑥. Sketch map of special vacuum dry procedure

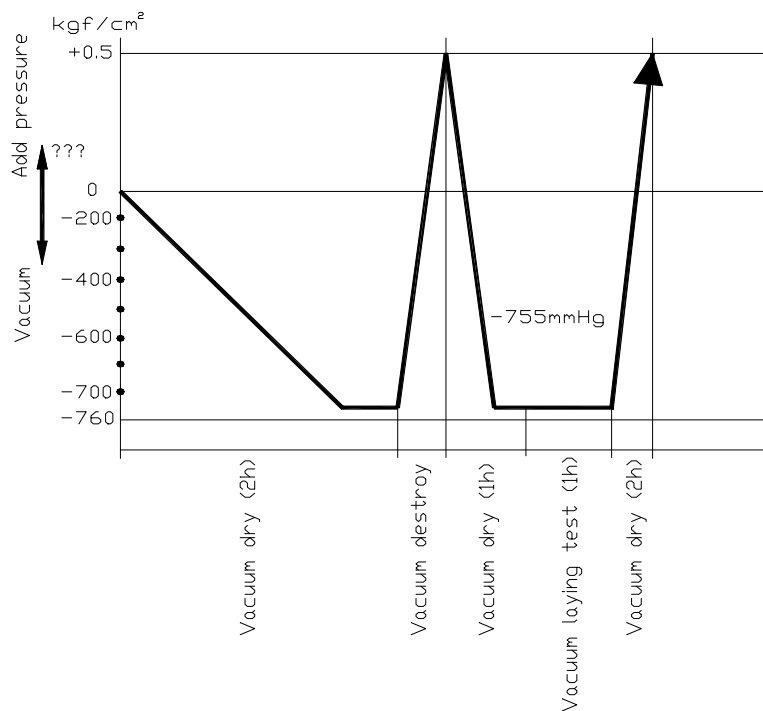

3 Additional Refrigerant Charge

Caution

- Refrigerant cannot be charged until field wiring has been completed.
- Refrigerant may only be charged after performing the leak test and the vacuum pumping.
- When charging a system, care shall be taken that its maximum permissible charge is never exceeded, in view of the danger of liquid hammer.
- Charging with an unsuitable substance may cause explosions and accidents, so always ensure that the appropriate refrigerant is charged.
- Refrigerant containers shall be opened slowly.
- Always use protective gloves and protect your eyes when charging refrigerant.

The outdoor unit is factory charged with refrigerant. Calculate the added refrigerant according to the diameter and the length of the liquid side pipe of the outdoor unit/indoor unit

R(g)	D(mm)	Φ6.4	Φ9.5
L(m)		—	—
Less than 5m (One-way)		—	—
Added Refrigerant When Over 5m (One-way)		12g/m × L	24g/m × L

Remark:

R (g): Additional refrigerant to be charged

L (m): The length of the refrigerant pipe (one-way)

D (mm): Liquid side piping

4 Water Drainage

4.1 Gradient and Supporting

4.1.1 Keep the drainpipe sloping downwards at a gradient of at least 1/100. Keep the drainpipe as short as possible and eliminate the air bubble.

4.1.2 The horizontal drainpipe should be short. When the pipe is too long, a prop stand must be installed to keep the gradient of 1/100 and prevent bending. Refer to the following table for the specification of the prop stand.

	Diameter	Distance between the prop stands
Hard PVC pipe	25~40mm	1~1.5m

4.1.3. Precautions

- ① The diameter of drainpipe should meet the drainage requirement at least.
- ② The drainpipe should be heat-insulated to prevent atomization.
- ③ Drainpipe should be installed before installing indoor unit. After powering on, there is some water in water-receiver plate. Please check if the drain pump can operate correctly.
 - ④ All connection should be firm.
 - ⑤ Wipe color on PVC pipe to note connection.
 - ⑥ Climbing, horizontal and bending conditions are prohibited.
 - ⑦ The dimension of drainpipe can't less than the connecting dimension of indoor drainpipe.
 - ⑧ Heat-insulation should be done well to prevent condensation.
 - ⑨ Indoor units with different drainage type can't share one convergent drainpipe.

4.2 Drainpipe Trap

4.2.1. If the pressure at the connection of the drainpipe is negative, it needs to design drainpipe trap.

4.2.2. Every indoor unit needs one drainpipe trap.

4.2.3. A plug should be designed to do cleaning.

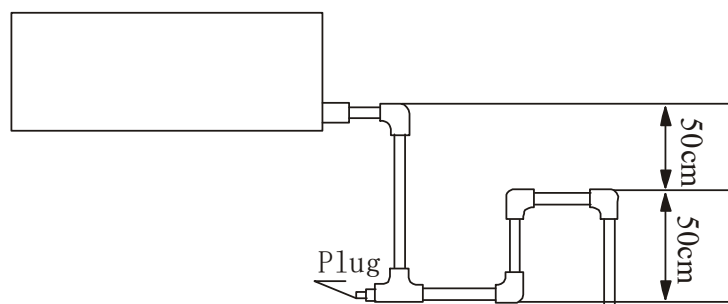

4.3 Upwards drainage (drain pump)

For Four-way cassette (compact)

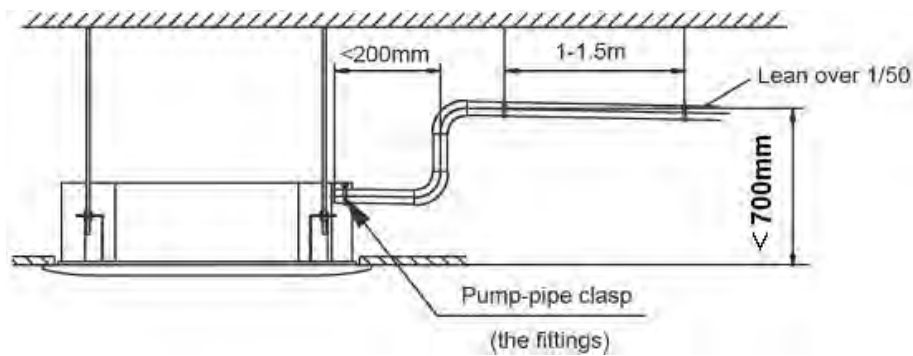

For Round-way cassette

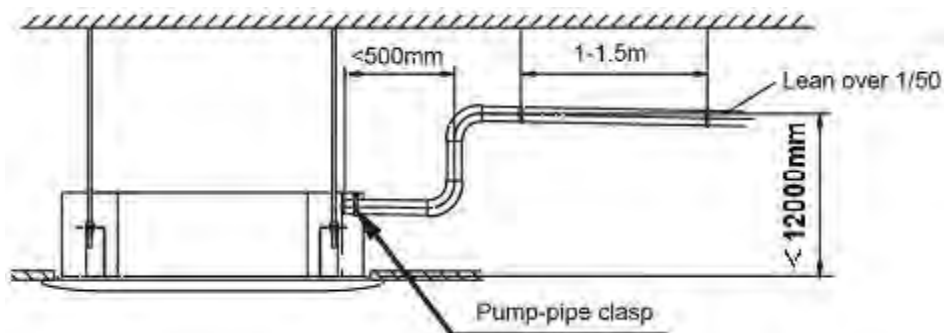

4.4 Convergent drainage

4.4.1. The number of indoor units should be as small as possible to prevent the traverse main pipe overlong.

4.4.2. Indoor unit with drain pump and indoor unit without drain pump should be in different drainage system.

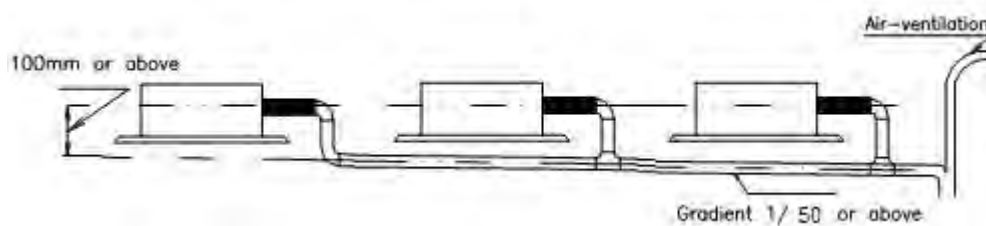

4.4.3. Selecting the diameter

Number of connecting indoor units → Calculate drainage volume → Select the diameter
 Calculate allowed volume = Total cooling capacity of indoor units(HP)×2 (l/ hr)

	Allowed volume(lean 1/50) (l/ hr)	I.D. (mm)	Thick
Hard PVC	$\infty \leq 14$	$\phi 25$	3.0
Hard PVC	$14 < \infty \leq 88$	$\phi 30$	3.5
Hard PVC	$88 < \infty \leq 334$	$\phi 40$	4.0
Hard PVC	$175 < \infty \leq 334$	$\phi 50$	4.5
Hard PVC	$334 < \infty$	$\phi 80$	6.0

4.5 Drainage test

4.5.1 Drainage without drain pump

After finishing drainpipe installation, pour some water into the water receiver plate to check if the water flows smoothly.

4.5.2 Drainage with drain pump

① Poke the Water Level Switch, remove the cover, use water pipe to pour 2000ml water into the water receipt plate through the water inlet.

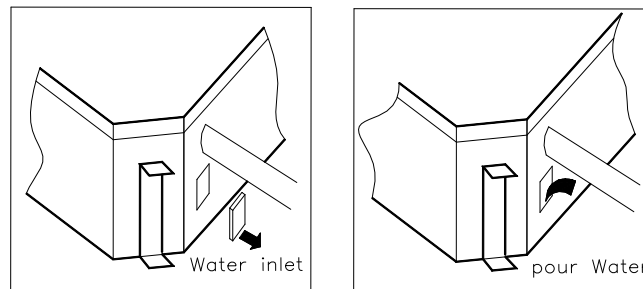

② Turn on the power to Cooling operation. Check the pump's operation and switch on the Water Level Switch. Check the pump's sound and look into the transparent hard pipe in the outlet at the same time to check if the water can discharge normally.

③ Stop the air conditioner running, turn off the power, and put back the cover.

- Stop the air conditioner. After 3 minutes, check if it has abnormality. If the collocation of drainpipes is illogical, the water will flow back overfull, which will cause the alarm lamp flashes, even overflow from the water receipt plate.
- Keep on pouring water until it gives an alarm signal for high water level, check if the pump drains water at once. If the water level can't fall below the alarmed water level after 3 minutes, the air conditioner will stop. Turn off the power and drain the remained water, and then turn on the air conditioner.

Note: the drain stuff in the main water receipt plate is for maintenance. Stuff up the drain stuff to prevent water leakage.

5 Insulation Work

5.1 Insulation material and thickness

5.1.1. Insulation material

Insulation material should adopt the material which is able to endure the pipe's temperature: no less than 70°C in the high-pressure side, no less than 120°C in the low-pressure side (For the cooling type machine, no requirements at the low-pressure side.)

◆ Example: Heat pump type----Heat-resistant Polyethylene foam (withstand above 120°C)

Cooling only type----Polyethylene foam (withstand above 100°C)

5.1.2. Thickness choice for insulation material

Insulation material thickness is as follows:

	Pipe diameter (mm)	Adiabatic material thickness
Refrigerant pipe	Φ6.4—Φ25.4	10mm
	Φ28.6—Φ38.1	15mm
Drainage pipe	Inner diameterΦ20—Φ32	6mm

5.2 Refrigerant pipe insulation

5.2.1. Work Procedure

① Before laying the pipes, the non-jointing parts and non-connection parts should be heat insulated.

② When the gas proof test is eligible, the jointing area, expanding area and the flange area should be heat insulated

5.2.2. Insulation for non-jointing parts and non-connection parts

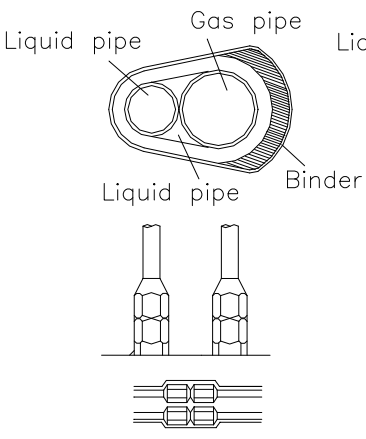
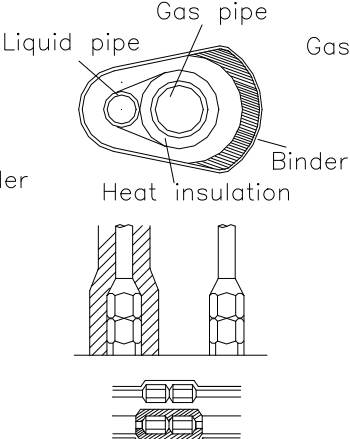
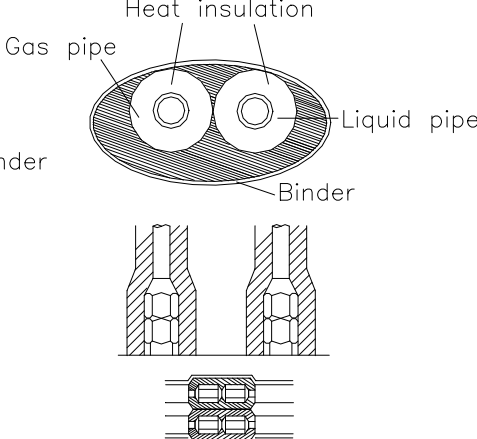
wrong	right	
Gas pipe and liquid pipe should not be put together to insulate	Insulate the gas pipe (cooling only)	Insulate the gas pipe and liquid pipe
		

For construction convenience, before laying pipes, use insulation material to insulate the pipes to be dealt with, at the same time, at two ends of the pipe, remain some length not to be insulated, in order to be welded and check the leakage after laying the pipes.

5.2.3. Insulate for the jointing area, expanding area and the flange area

- ① Insulate for the jointing area, expanding area and the flange area should be done after checking leakage of the pipes
- ② Make sure there's no clearance in the joining part of the accessorial insulation material and local preparative insulation material.

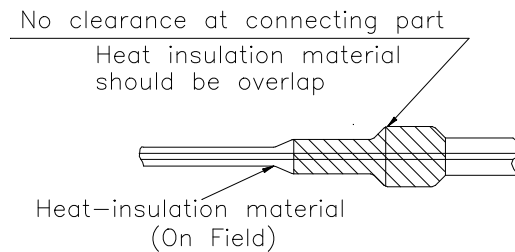

5.3 Drainage pipe insulation

The connection part should be insulated, or else water will be condensing at the non-insulation part.

5.4 Note

5.4.1 The jointing area, expanding area and the flange area should be heat insulated after passing the pressure test

5.4.2 The gas and liquid pipe should be heat insulated individually, the connecting part should be heat insulated individually.

5.4.3 Use the attached heat-insulation material to insulate the pipe connections (pipes' tie-in ,expand nut) of the indoor unit

6. Test Operation

(1) The test operation must be carried out after the entire installation has been completed.

(2) Please confirm the following points before the test operation.

- The indoor unit and outdoor unit are installed properly.
- Tubing and wiring are correctly completed.
- The refrigerant pipe system is leakage-checked.
- The drainage is unimpeded.
- The ground wiring is connected correctly.
- The length of the tubing and the added stow capacity of the refrigerant have been recorded.
- The power voltage fits the rated voltage of the air conditioner.
- There is no obstacle at the outlet and inlet of the outdoor and indoor units.
- The gas-side and liquid-side stop valves are both opened.
- The air conditioner is pre-heated by turning on the power.

(3) According to the user's requirement, install the remote controller when the remote controller's signal can reach the indoor unit smoothly.

(4) Test operation

Set the air conditioner under the mode of "COOLING" with the remote controller, and check the following points.

Indoor unit

- Whether the switch on the remote controller works well.
- Whether the buttons on the remote controller works well.
- Whether the air flow louver moves normally.
- Whether the room temperature is adjusted well.
- Whether the indicator lights normally.
- Whether the temporary buttons works well.
- Whether the drainage is normal.
- Whether there is vibration or abnormal noise during operation.

Outdoor unit

- Whether there is vibration or abnormal noise during operation.
- Whether the generated wind, noise, or condensed of by the air conditioner have influenced your neighborhood.
- Whether any of the refrigerant is leaked.

Part 5 Controller

1.Wired Controller..... 54

1 Wired Controller

RCW25

I. Use-method

The control panel of wire controller is responsible for controlling the operation status of the system by the button and displaying the working status of the entire system by its LCD screen, and is responsible for communicating with the control board of the system.



Fig1 Appearance of Wire Controller

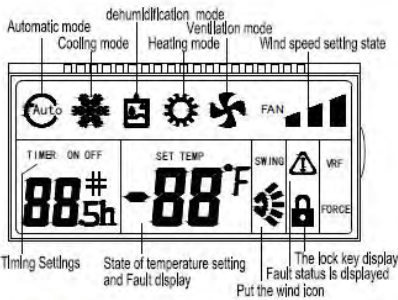

Fig2 LCD display content of Wire Controller

Operation and Instruction:

"ON/OFF" Button:

- 1) Control the On/Off status of the system.
- 2) Press and hold the On/Off button when the wire controller is powered on, to go into the self-test mode. And then you can release the button.

"MODE" Button:

When the air conditioning is powered on, every time you press mode button or the mode button of remote controller, the mode will change in the following sequence.

Auto Mode→Refrigeration→Dehumidification→Heating→Ventilation→Auto Mode

"TEMP+" and "TEMP-" Button ("▲", "▼") :

- 1) Boot state, press "▲" and "▼" button, increase/decrease the setting temperature. Refrigeration, Dehumidification, Ventilation and Heating mode Scope of temperature setting: 16 °C ~ 32 °C ;The setting temperature do not adjust in Auto Mode .

- 2) Press the "▲" and "▼" button for 3s simultaneously to lock this button. At this time, It will display the locking icon in LCD. Deactivate this button, and press the "▲" and "▼" button again simultaneously.

"TIMER" Button

Set Timing On or Timing Off. The wire controller to set the time range as 1-24h.

- 1) Press the Timer button in the Off status to go into the Timing On for 1 hour, and then press the Timer button plus 1 until it is timing on for 24h. At this time, if you press the Timer button, it will deactivate Timing On.

- 2) Press the Timer button in the On status to go into the Timing Off for 1 hour, and then press the Timer button plus 1 until it is timing off for 24h. At this time, if you press the Timer button, it will deactivate Timing Off.

"FAN SPEED" Button:

- 1) The Fan Speed button is valid in the "Cooling mode", "Heating mode" and "Ventilation mode".

- 2) Press the Fan Speed button of the wire controller or the Volume button of the remote controller in the Cooling mode, Heating mode or Ventilation mode, and the volume changes as follows:

High speed → Middle speed → Low speed → Auto wind

- 3) There is no Auto wind in the Ventilation mode.

"SWING" Button:

- 1) Press it to display the Swing icon. The Swing icon will swing back and forth.

- 2) Press the Swing button, and the upper and lower wind deflectors will swing within the specified range automatically, and the left and right wind deflectors will swing within the specified range automatically, and press it again to stop the swing.

26°C/CHECK Button Function:

- 1) Short press this button, Enter a state of energy saving of 26 °C, namely the setting temperature is 26 °C. this function under the boot of Refrigeration and Heating mode is effective.

- 2) Long press this button, will enter the query condition: It will exit the query condition, when you press this button again and five seconds is not operating in the condition of the query.

By pressing "▲" and "▼" button to check the temperature in the query condition. 1 is Indoor environment temperature, 2 is Indoor pipe temperature, 3 is outdoor pipe temperature

Description of DIP Switch:

	2 ON	2 OFF
3 ON	-4°C	-2°C
3 OFF	2°C	0°C
	ON	OFF
1	The old protocol	The new protocol
4	with power failure memory	witho ut power failure memory

- 1) The second and third bits of the DIP switch will select the compensation value of the indoor temperature. The compensation value is -4°C when the second and third bits are ON, and the

compensation value is 0°C when the second and third bits are OFF. The compensation value is 2°C when the second bit is ON and the third bit is OFF, and the compensation value is -2°C when the second bit is OFF and the third bit is On (for the wire controller sensor only).

- 2) The first bit of the DIP switch indicates to select the new or old protocol. Light commercial units select the new protocol.

- 3) The fourth bit ON of the DIP switch indicates it is With Power Failure Memory function, and the fourth bit OFF indicates it is Without Power Failure Memory.

NOTE: Just need to dial the code when matching the old type. Detailed please see after-sales guidance !

II. Installation of Wire Controller

Safety Precautions

- ! Read the safety precautions carefully before installation.
- ! The following is the important content to be paid for the safety, be sure to follow it.
- ! The meaning of each part:

Warning:	Indicate it may cause the death or serious injury for the improper operation.
Note:	Indicate it may cause the death or serious injury for the improper operation.

Notes:

- Please do not install the wire controller in damp or direct sunlight places.
- Please do not hit, throw and frequent disassembling the wire controller.
- Please do not operating the wire controller with Wet hand ; Don't make any fluid into the wire controller .
- Please do not do dismantling the wire controller without authorization. Please consult after-sales maintenance personnel If you have a problem .
- To prevent water and dust into the wire controller, Affect the wire controller normal use. Please dismantle the wire controller When the indoor decoration and maintenancee .

Installation and disassembly of the wire controller

1. The installation position and requirements of the wire controller

- 1) Please do not install the wire controller in damp or direct sunlight places.
- 2) Please do not install the wire controller in the places, where is near the high temperature or easy to splash water.
- 3) To avoid the interference of the neighbors' remote controller which has the same model , then cause abnormal work. Please do not install the wire controller where the face up to the window.
- 4) Before installation , please cut off the power which is Buried in the wall mounting holes. The whole installation process does not allow operation with power.
- 5) In order to avoid the unit by reason of electromagnetic interference caused by abnormal work . When wiring , please pay attention to the following matters.
 - A) Ensure that communication line access right, otherwise will lead to communication failures.
 - B) If the air conditioning unit is installed on the places , which is influence by electromagnetic interference . the wire controller signal lines must use shielded twisted-pair cable .
- 6) The standard accessories which is installation need to prepare : installed inside a wall socket bottom box, controller base plate, screw the M4 x 25, control panel.

2. The installation of the wire controller

First of all, the wire controller signal line connection mode is as follows :

- 1) Open interior electrical lifted the lid, and the signal wires through the rubber ring;
- 2) Plug the wire controller signal lines within the five core needle base on the indoor machine circuit boards, and using cable tie line tied tightly fixed.

Next, the wire controller installation steps as shown in the figure below:

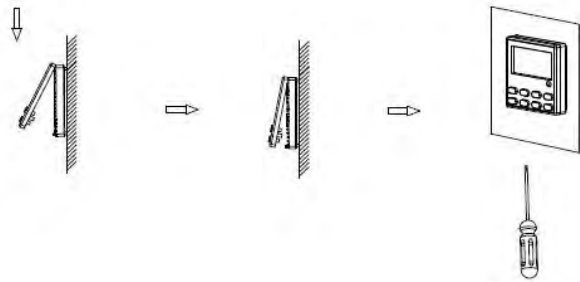
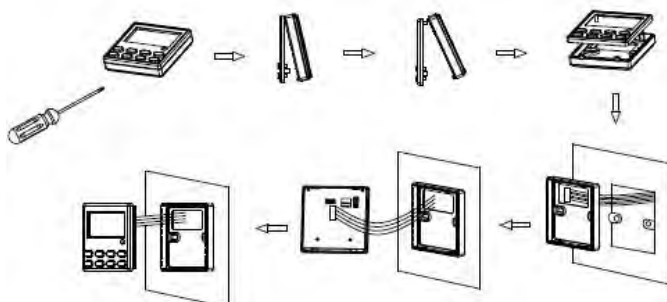

Connect the wire controller in the way as shown in the figure below

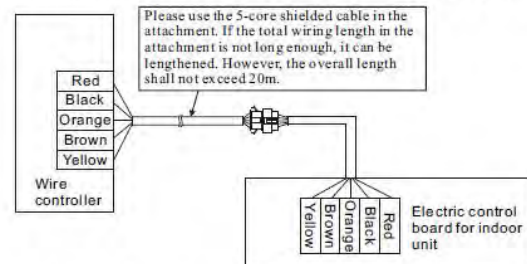

Brief description of the installation process is as follows

- 1) The signal lines of short through rectangle hole of the wire controller bottom plate, and then pull out five core twisted pair from the wall installation hole. Finally connect the line and the other end.
- 2) Use screws M4 x 25 to fix the controller base plate on the mounting holes of the wall.
- 3) Put the wire controller panel and floor buttons together, and this installation is complete. When installation, please reserve a certain length of the line at the bottom of box, to facilitate maintenance later removed.

3. Disassembly of the wire controller

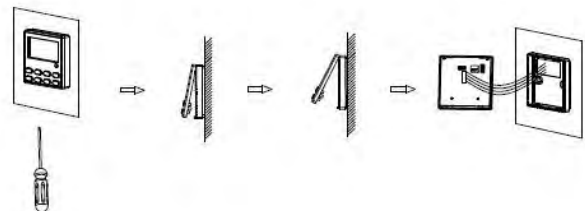

! After the completion of the installation, confirm there is no abnormality for the commissioning, and deliver the instruction to customers for storage.

Note:

- It may cause the rear cover deformed if the screw is tightened too much.
- It is necessary to reserve a certain length for the connecting cable of the wire controller during the installation, so as to take down the wire controller for the maintenance.



GROUPE AIRWELL
10 RUE DU FORT DE SAINT CYR
78180 MONTIGNY LE BRETONNEUX
FRANCE
www.airwell.com