

Airwell

Just feel well

SERVICE MANUAL

One Way Cassette Type Indoor Unit
CVPA Range R410a
English Manual

CVPA-025/022N-01M22
CVPA-035N-01M22



IMPORTANT NOTE:

Read this manual carefully before installing or operating your new air conditioning unit. Make sure to save this manual for future reference.

1. One Way Cassette Type Indoor Unit

1.1 Features



- DC fan motor, higher efficiency
- Only 185mm thickness, allowing more flexible design
- Low sound level, high comfort
- Built-in high lift drain pump.
- No need of maintenance port, convenient and artistic

1.2 Specification

MODEL		CVPA-022N-01M22	
Power supply		Ph-V-Hz	1/220-230/50/60
Cooling	Capacity	kBtu/h	7.5
	Capacity	kW	2.2
	Power input	W	21
	Current	A	0.1
Heating	Capacity	kBtu/h	8.5
	Capacity	kW	2.5
	Power input	W	21
	Current	A	0.1
	Heating capacity at low temp.	kW	2
Operating current		A	0.1
Indoor motor	Brand		Broad Ocean
	Model		ZWK465B500015
	Type		DC
	Insulation class		E
	IP class		IP20
	Power input	W	88
	Power output	W	70
	Capacitor	μF	/
	Speed (High/Middle/Low)	rpm	700/600/550
Indoor fan	Brand		Shunwei
	Type		Cross-flow
	Quantity		1
Indoor coil	a. Number of rows		2
	b. Tube pitch (a)×row pitch (b)	mm	21*13.3
	c. Fin spacing	mm	1.4
	d. Fin type (code)		Hydrophilic aluminum
	e. Tube outside dia. and type	mm	Φ7
	f. Coil length×height×width	mm	675*168*13.3&675*84*13.3
	g. Number of circuits		3

MODEL			CVPA-022N-01M22
Cabinet	Cabinet coating type		Galvanized
	Cabinet salt spray test duration	Hour	100
	Control box IP class		IP40
Construction	Sheet metal thickness		3
	Drain pan material		ABS
	Drain pan insulation		UL-V0
	Drain pump option		Standard 1200mm
	Branch outlet option		no
Indoor wall	Material		ABS
	Thickness	mm	3
	Double or single skin		Single
Air filter	Material		ABS
	Mesh		100
	Pressure drop	Pa	5
Piping dimension	Liquid pipe	mm	6.35
	Gas pipe	mm	9.52
	Drain hose	mm	Φ32
Panel	Model		Panel for CVPA to s12
	Dimension	mm	1050/560/122
	Packing	mm	1133/623/197
	Net weight	kg	5.3
	Gross weight	kg	8.3
Fresh air dimension	mm		/
Sound pressure level (H/M/L)	dB (A)		32/29/24
Sound power level (H/M/L)	dB (A)		46/43/38
Standard static pressure	Pa		0
Indoor air flow (H/M/L)	m ³ /h		530/490/450
Dimension (W*H*D)	mm		875/505/185
Packing (W*H*D)	mm		1028/581/270
Net weight	kg		15.3
Gross weight	kg		17.9
Nominal condition: indoor temperature (cooling): 27DB (°C)/19WB (°C), indoor temperature (heating): 20DB (°C) Outdoor temperature (cooling): 35DB (°C)/24WB (°C), outdoor temperature (heating): 7DB (°C)/6WB (°C) The noise level will be measured in the third octave band limited values, using a Real Time Analyser calibrated sound intensity meter. It is a sound pressure noise level.			

MODEL		CVPA-025N-01M22	CVPA-035N-01M22
Power supply		Ph-V-Hz	1/220-230/50/60
Cooling	Capacity	kBtu/h	9.6
	Capacity	kW	2.8
	Power input	W	21
	Current	A	0.1
Heating	Capacity	kBtu/h	10.9
	Capacity	kW	3.2
	Power input	W	21
	Current	A	0.1
	Heating capacity at low temp.	kW	2.5
Operating current		A	0.1
Indoor motor	Brand		Broad Ocean
	Model		ZWK465B500015
	Type		DC
	Insulation class		E
	IP class		IP20
	Power input	W	88
	Power output	W	70
	Capacitor	μF	/
	Speed (High/Middle/Low)	rpm	700/600/550
Indoor fan	Brand		Shunwei
	Type		Cross-flow
	Quantity		1
Indoor coil	a. Number of rows		2
	b. Tube pitch (a)×row pitch (b)	mm	21*13.3
	c. Fin spacing	mm	1.4
	d. Fin type (code)		Hydrophilic aluminum
	e. Tube outside dia. and type	mm	Φ7
	f. Coil length×height×width	mm	675*168*13.3&675*84*13.3
	g. Number of circuits		3

MODEL			CVPA-025N-01M221	CVPA-035N-01M22
Cabinet	Cabinet coating type		Galvanized	Galvanized
	Cabinet salt spray test duration	Hour	100	100
	Control box IP class		IP40	IP40
Construction	Sheet metal thickness		3	3
	Drain pan material		ABS	ABS
	Drain pan insulation		UL-V0	UL-V0
	Drain pump option		Standard 1200mm	Standard 1200mm
	Branch outlet option		no	no
Indoor wall	Material		ABS	ABS
	Thickness	mm	3	3
	Double or single skin		Single	Single
Air filter	Material		ABS	ABS
	Mesh		100	100
	Pressure drop	Pa	5	5
Piping dimension	Liquid pipe	mm	6.35	6.35
	Gas pipe	mm	9.52	12.7
	Drain hose	mm	Φ32	Φ32
Panel	Model		Panel for CVPA to s12	Panel for CVPA to s12
	Dimension	mm	1050/560/122	1050/560/122
	Packing	mm	1133/623/197	1133/623/197
	Net weight	kg	5.3	5.3
	Gross weight	kg	8.3	8.3
Fresh air dimension	mm	/	/	
Sound pressure level (H/M/L)	dB (A)		32/29/24	34/30/25
Sound power level (H/M/L)	dB (A)		46/43/38	48/44/39
Standard static pressure	Pa		0	0
Indoor air flow (H/M/L)	m ³ /h		530/490/450	550/530/490
Dimension (W*H*D)	mm		875/505/185	875/505/185
Packing (W*H*D)	mm		1028/581/270	1028/581/270
Net weight	kg		15.3	15.3
Gross weight	kg		17.9	17.9
Nominal condition: indoor temperature (cooling): 27DB (°C)/19WB (°C), indoor temperature (heating): 20DB (°C) Outdoor temperature (cooling): 35DB (°C)/24WB (°C), outdoor temperature (heating): 7DB (°C)/6WB (°C) The noise level will be measured in the third octave band limited values, using a Real Time Analyser calibrated sound intensity meter. It is a sound pressure noise level.				

1.3 Dimension

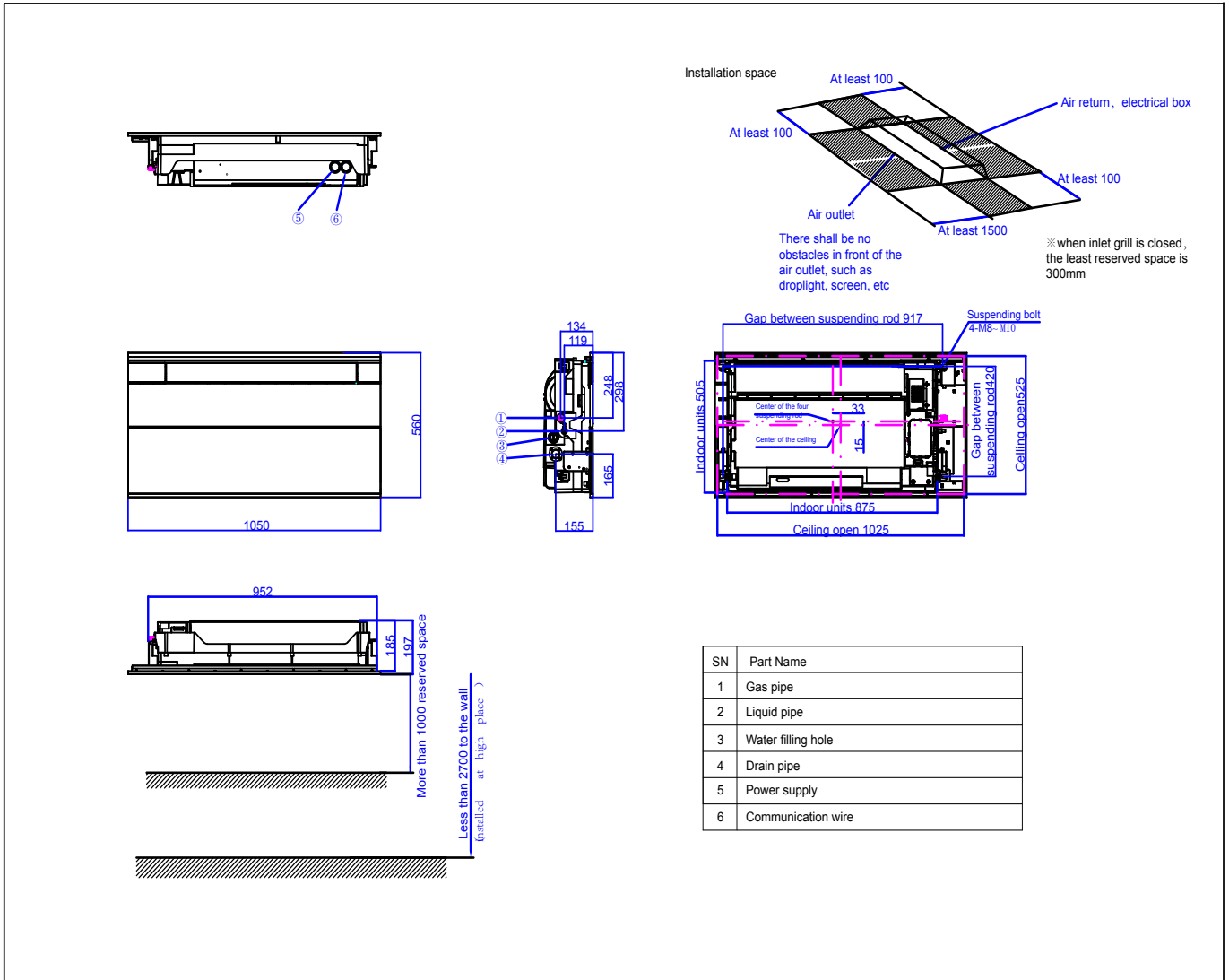

1.4 Piping diagram

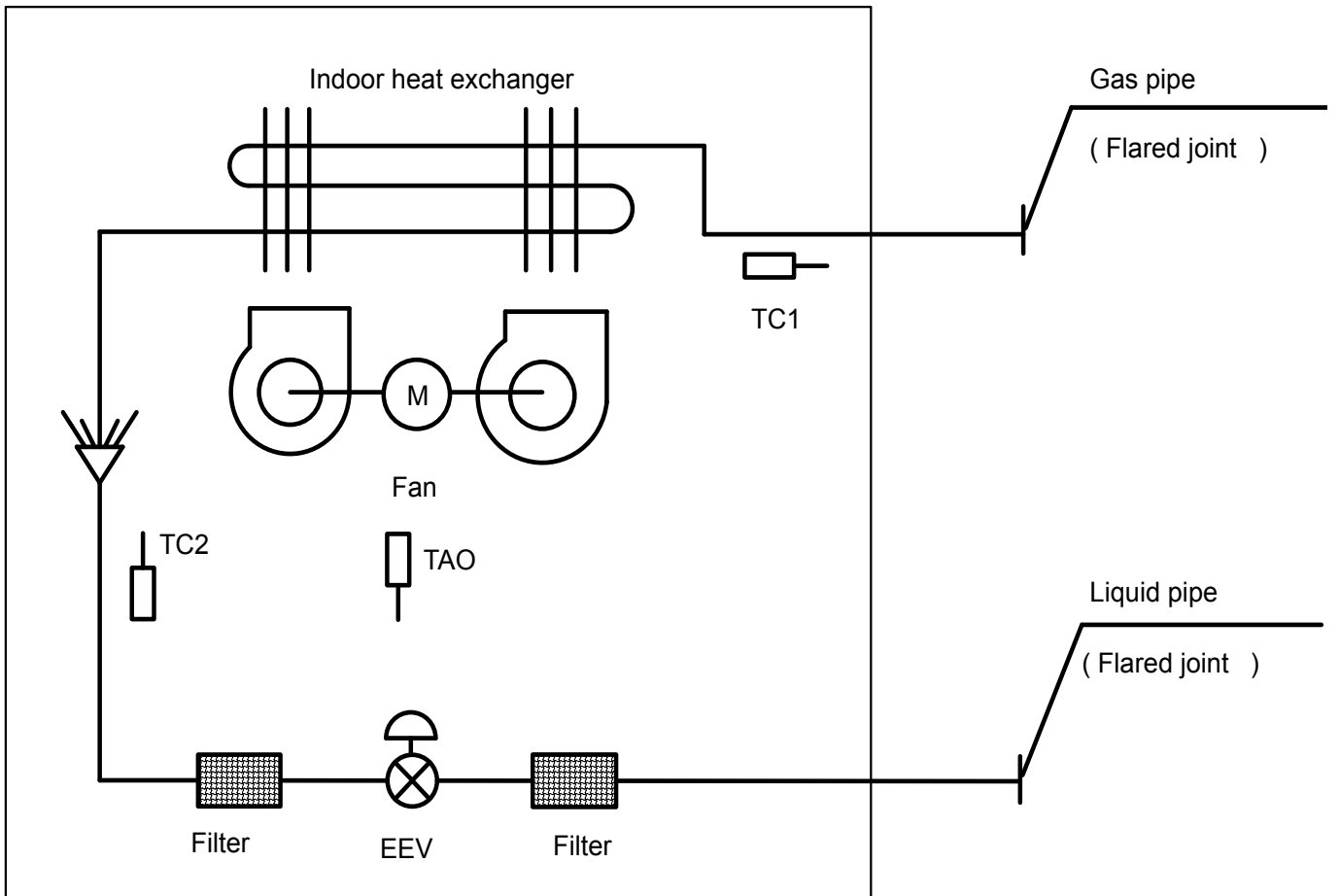

1.5 Wiring diagram

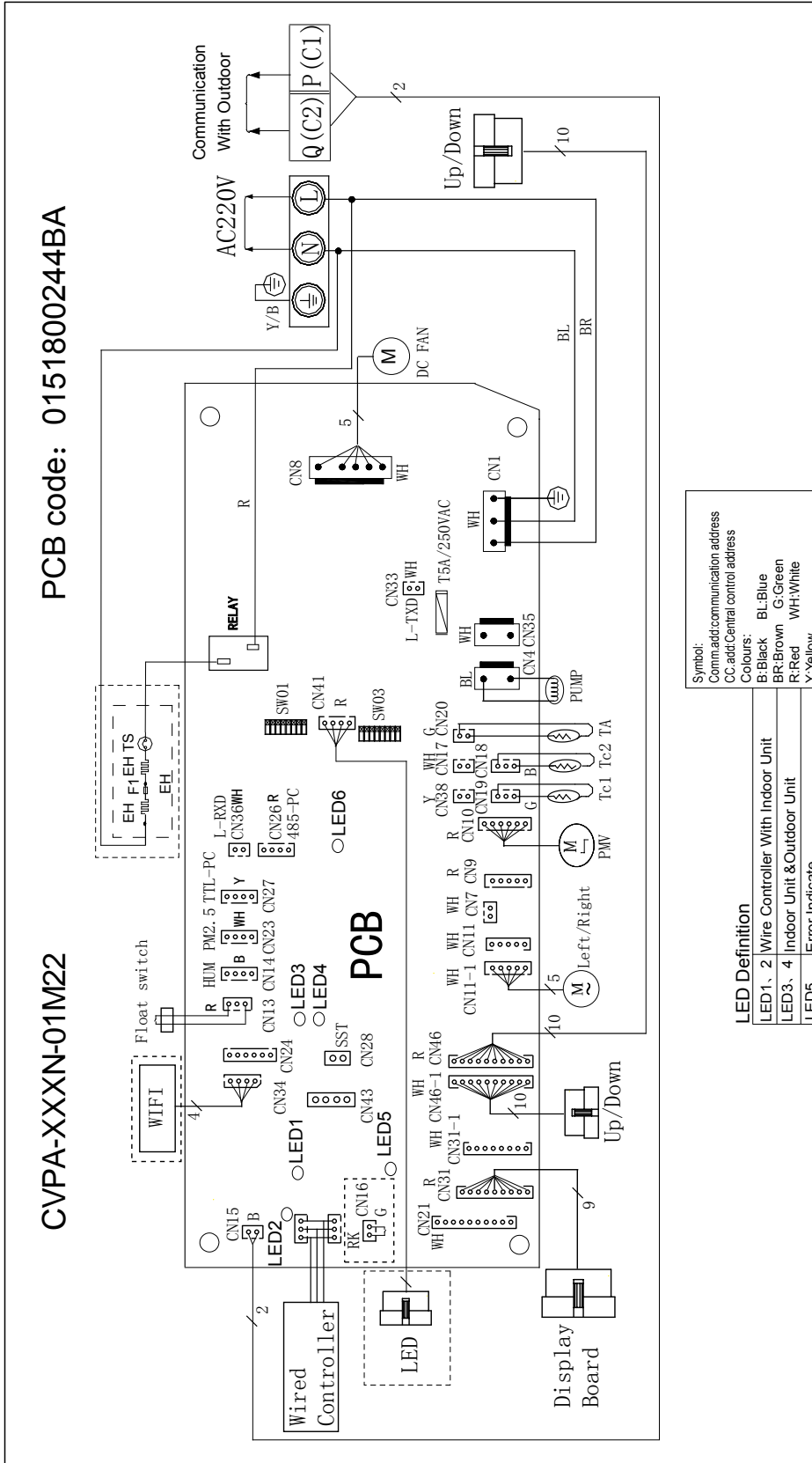

1.6 Electric characteristics

Model	Units				Power supply		Indoor fan motor		Power input (w)	
	Phase	FQY	Voltage	Volt. range	MCA	MFA	Output (W)	FLA	Cooling	Heating
CVPA-022N-01M22	1	50/60	220	198~242	0.088	0.28	70	0.07	21	21
CVPA-025N-01M22	1	50/60	220	198~242	0.088	0.28	70	0.07	21	21
CVPA-035N-01M22	1	50/60	220	198~242	0.088	0.28	70	0.07	23	23

Symbols:

MCA: Min. circuit amps (A)

MFA: Max. fuse amps of circuit breaker

Output: Fan motor rated output (w)

FLA: Full load amps (A)

Note:

1. Voltage range

The units are applicable for the electrical systems where voltage supplied to unit is in the range.

2. Maximum allowable voltage unbalance between phases is 2%.

3. $MCA=1.25*FLA$ $MFA\leq 4*FLA$

4. Power supply uses the circuit breaker.

1.7 Air velocity and temperature distribution

a. Cooling / Air velocity distribution

Cooling

Blow angle: 40

Air velocity distribution

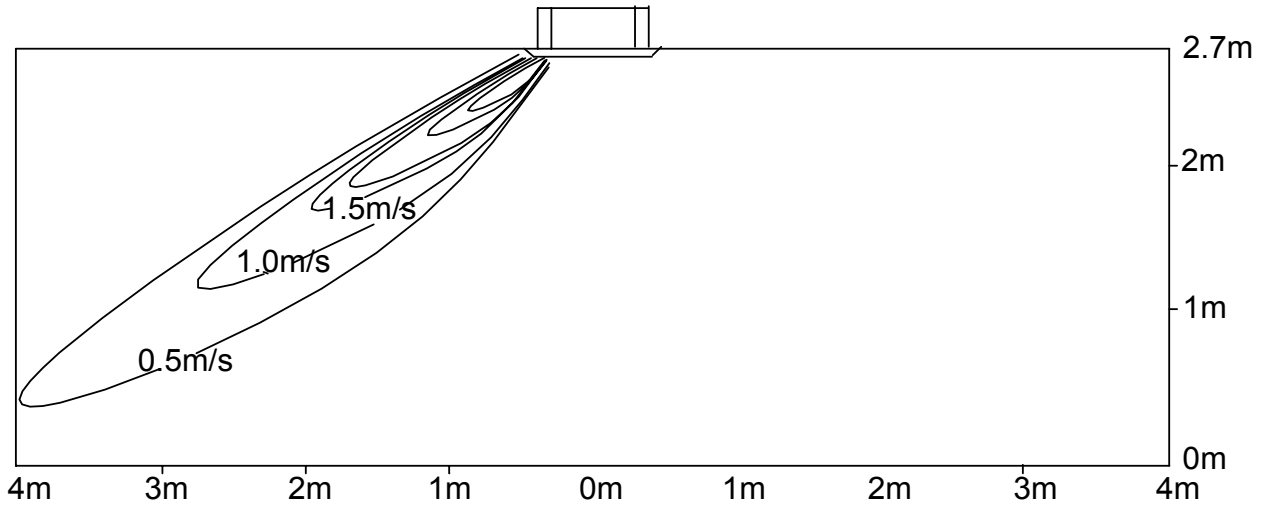

b. Cooling / Temperature distribution

Cooling

Blow angle: 40

Temperature distribution

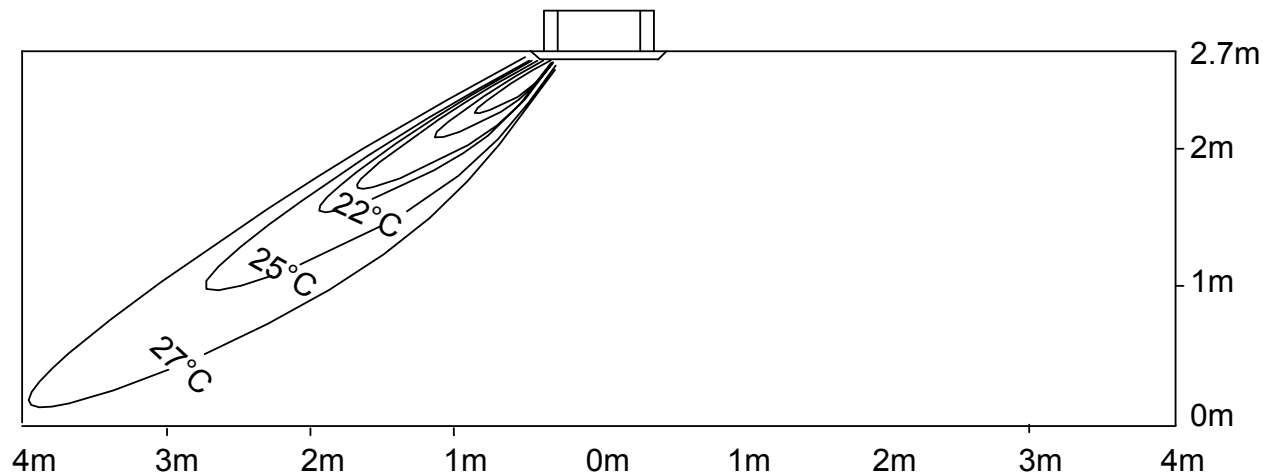

c. Heating / Air velocity distribution

Heating

Blow angle: 70

Air velocity distribution

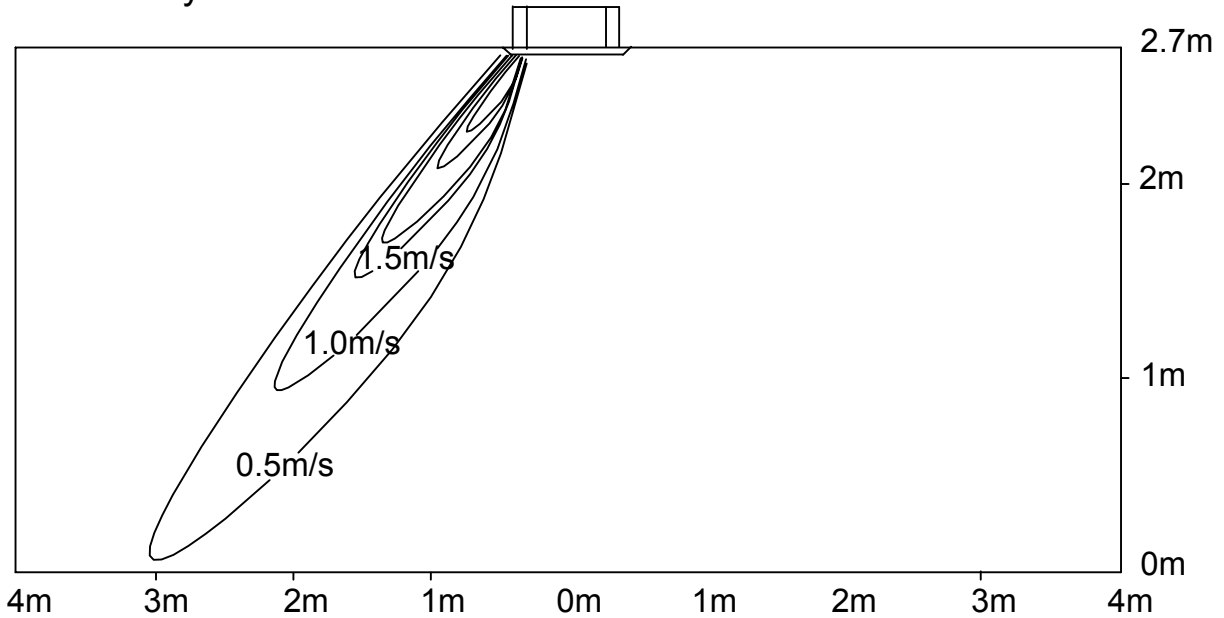

d. Heating / Temperature distribution

Heating

Blow angle: 70

Temperature distribution

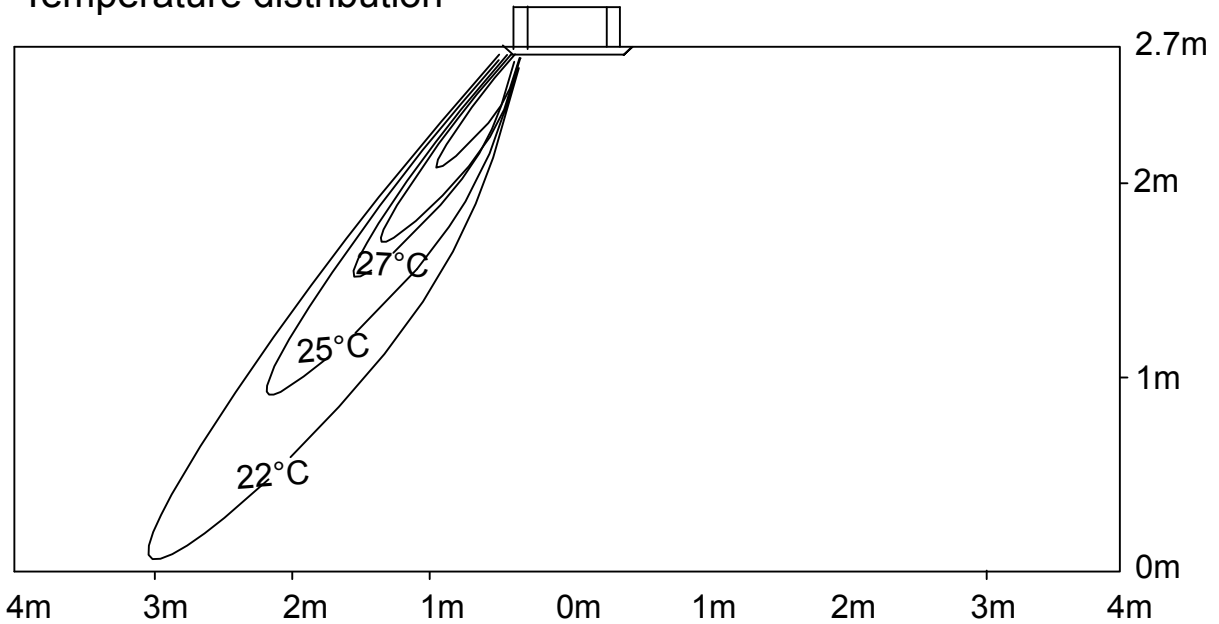

1.8 Sound pressure level

1) Testing illustrate:

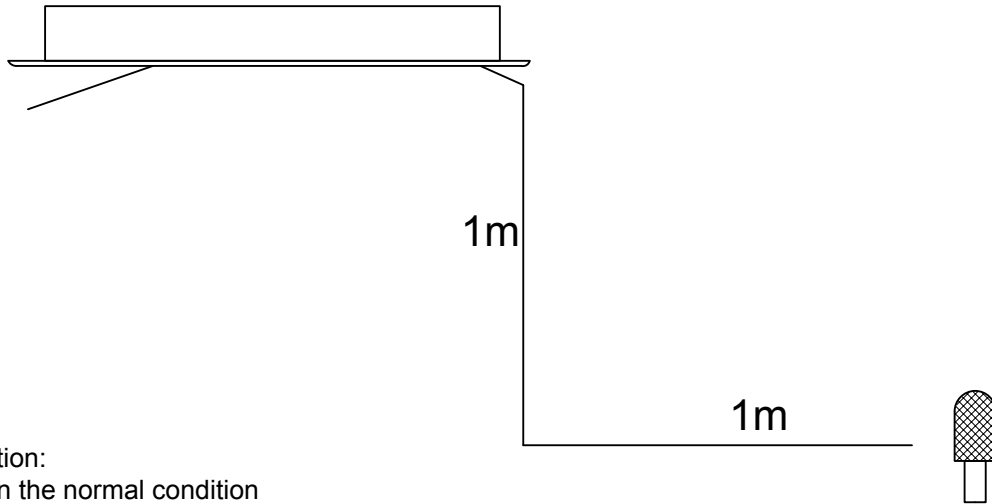

2) Testing condition:

- a: Unit running in the normal condition
- b: Test in the semi-anechoic chamber
- c: Noise level varies from the actual factors, such as room structure, etc.

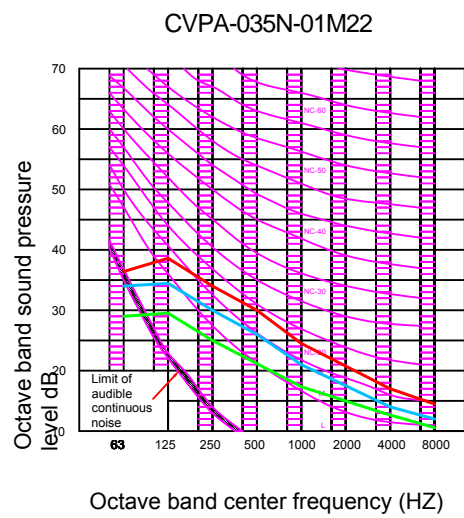
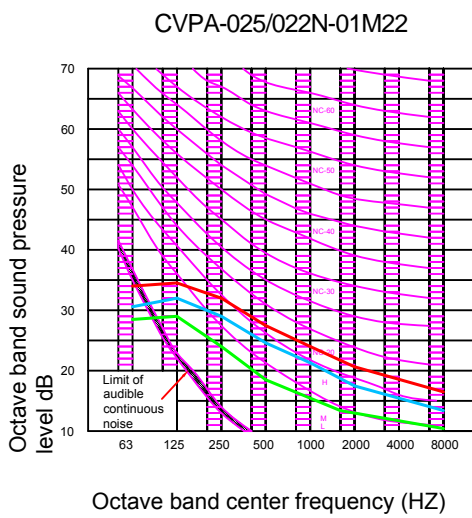

1.9 Installation

1.9.1 Parts and functions

Indoor unit

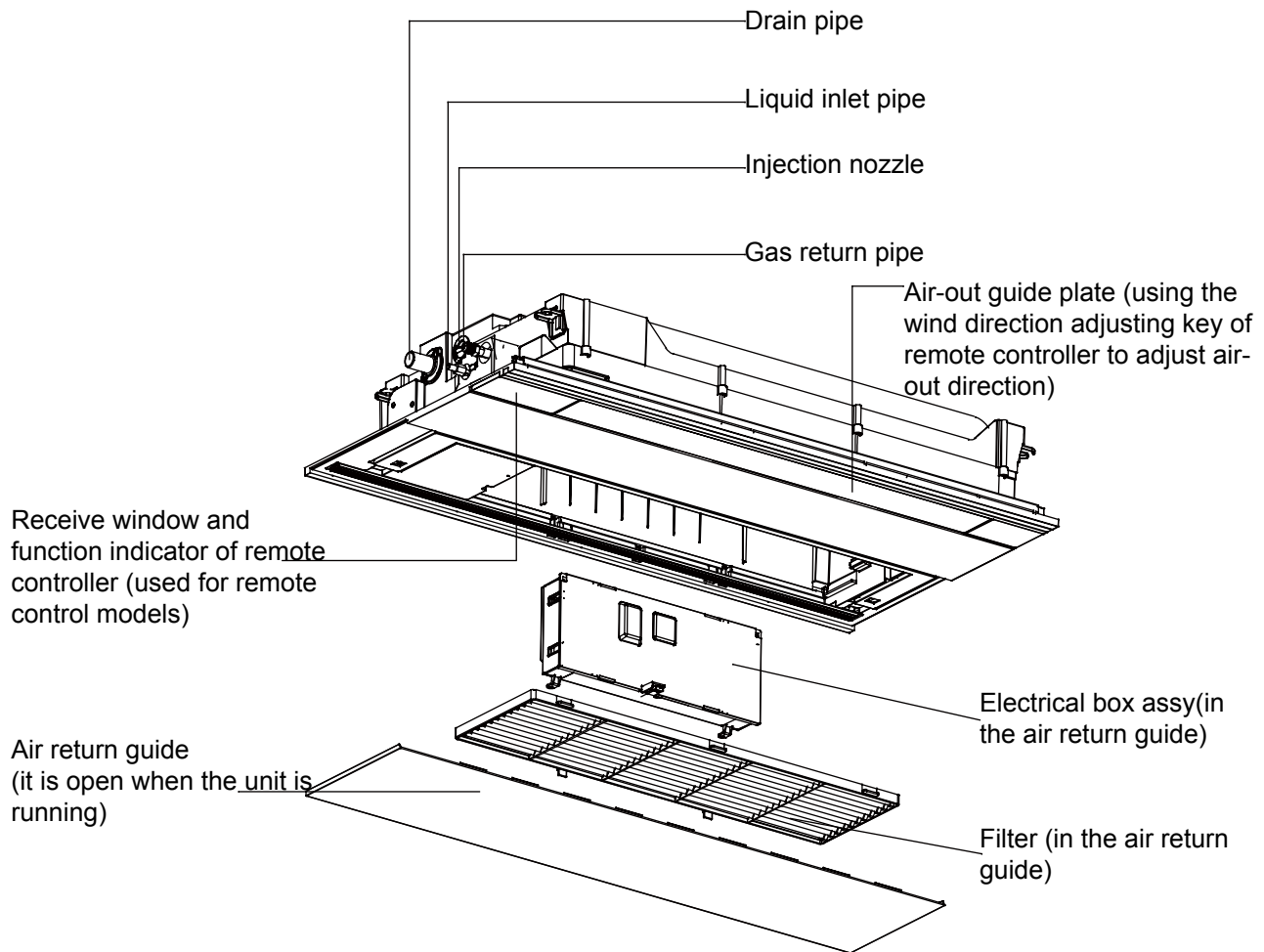

1.9.2 Safety



- If the air conditioner is transferred to a new user, this manual shall be transferred to the user, together with the conditioner.
- Before installation, be sure to read Safety Considerations in this manual for proper installation.
- The safety considerations stated below is divided into "⚠Warning" and "⚠ Attention". The matters on severe accidents caused from wrong installation, which is likely to lead to death or serious injury, are listed in "⚠ Warning". However, the matters listed in "⚠ Attention" are also likely cause the severe accidents. In general, both of them are the important items related to the security, which should be strictly abided by.
- After the installation, perform test run to make sure everything is in normal conditions, and then operate and maintain the air conditioner in accordance with the User Manual. The User Manual should be delivered to the user for proper keeping.
- Airwell is not responsible for any personnel damage or equipment damage caused by improper installation, improper commissioning, unnecessary maintenance and the wrong operation which violates the instructions in this manual or industry specifications and standards.



⚠WARNING

- Please ask the special maintenance station for installation and repair. Water leakage, electric shocks or fire accidents might be caused from improper installation if you conduct the installation by your own.
- The installation should be conducted properly according to this manual. Water leakage, electric shocks or fire accidents might be caused from improper installation.
- Please make sure to install the air conditioner on the place where can bear the weight of the air conditioner. The air conditioner can't be installed on the grids such as the non-special metal burglar-proof net. The place with insufficient support strength might cause the dropdown of the machine, which may lead to personal injuries.
- The installation should be ensured against typhoons and earthquakes, etc. The installation uncomformable to the requirements will lead to accidents due to the turnover of the machine.
- Specific cables should be used for reliable connections of the wirings. Please fix the terminal connections reliably to avoid the outside force applied on the cables from being impressed on the cables. Improper connections and fixings might lead to such accidents as heating or fire accidents.
- Correct shapes of wirings should be kept while the embossed shape is not allowed. The wirings should be reliably connected to avoid the cover and the plate of the electrical cabinet lipping the wiring. Improper installation might cause such accidents as heating or fire accidents.
- While placing or reinstalling the air conditioner, except the specific refrigerant (R410A), don't let the air go into the refrigeration cycle system. The air in the refrigeration cycle system might lead to the cracking or personal injuries due to abnormal high pressure of the refrigeration cycle system.
- During installation, please use the accompanied spare parts or specific parts. If not, water leakage, electric shocks, fire accidents or refrigerant leakage might be caused.
- Don't drain the water from the drainpipe to the waterspout where may exist harmful gases such as sulfured gas to avoid the harmful gases entering into the room.
- During installation, if refrigerant leakage occurs, ventilation measures should be taken, for the refrigerant gas might generate harmful gases upon contacting the flame.
- After installation, check if any refrigerant leakage exists. If the refrigerant gas leaks in the room, such things as air blowing heaters and stoves, etc. may generate harmful gases.
- Don't install the air conditioner at the places where the flammable gases may leak. In case the gas leakage occurs around the machine, such accidents as fire disasters may be caused.
- When installed in a smaller room, the appropriate measures must be taken to prevent the refrigerant concentration from exceeding the limit. Please contact the sales agent to contact the corresponding measures.
- Be sure to use a separate circuit to supply power. All the electrical work must be executed by the professional electrician, meanwhile met local laws and regulations and the instructions.
- The current-carrying conductor should be tightened before grounding the wire.
- Please turn off the power before touching the electronic parts.
- Do not touch the switch with wet hands to prevent electric shock.
- Please connect the remote control cable and the connection cable to no noise.

⚠CAUTION

- The drainpipe should be properly mounted according to this manual as to ensure the smooth drainage. In addition, heat preservation should be taken to avoid condensation. Improper drainpipe mounting might cause water leakage, which will get the articles at home wet.
- The refrigerant gas pipe and liquid pipe should be heat insulated to preserve heat. For inappropriate heat insulation, the water caused from the condensation will drop to get the article at home wet.
- The air conditioner should be effectively grounded. Electric shocks may occur if the air conditioner is ungrounded or inappropriately grounded. The wire for earthing shouldn't be connected to the connections on the gas pipe, water pipe, lightning rod or telephone.
- The breaker for electricity leakage should be mounted. If not, accidents such as electric shocks may happen.
- The installed air conditioner should be checked for electricity leakage by being powered.
- When install the remote controller, if the room has a fluorescent lamp (inverter controller or quick start mode), the signal transmission distance of the remote controller will be shortened. Please try to install the indoor unit away from the fluorescent lamp.
- If the ambient humidity bigger than 80%, when the water discharge hole be blocked or the filter becomes dirty, or airflow speed change, there maybe leads to condensing water drop down, and at the same time there maybe some drops of water spit out.

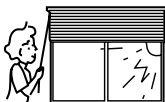
Notices during Operation	
■ If abnormal phenomena (such as the smell of fire), please cut off the power immediately and contact after-sales service personnel. In this case if you continue to use the air conditioning, it will be damaged and also may cause electric shock or fire accident.	
■ When remove, transfer or repair air conditioning, please contact with the after-sales service personnel. Improper maintenance may cause leakage, electric shock and fire hazard.	
■ Be sure to install a leakage circuit breaker and ground connection must be effective. The grounding wire can not be connected to the gas pipeline, water pipe, lightning rod or telephone ground line. Poor ground wire may cause electric shock.	
■ It cannot be used for the preservation of food, living creature, precise instrument and artworks, etc, otherwise damage may occur.	⊘
■ It is not allowed to put any heating apparatus under the indoor units, for the heat may cause distortion of the units.	 !
■ Flammable apparatus should not be placed in the place where the air conditioner wind could reach directly, or incomplete burning of the apparatus may be caused.	 ⊘
■ Do not touch the switch with the wet hand to avoid power shock.	⊘
■ Cleaning the unit with water may cause electric shock.	 ⊘
■ Do not use water heater or like next to the indoor unit and the wired controller. Water/power leakage or short circuit may happen if the steam generating apparatus is working next to machine.	⊘
■ Stop running and switch off the manual power switch when cleaning the unit.	⊘
■ Check the mount table of the air conditioner for damage for a long period of operation. If placed on the damaged table, the unit may drop down causing damage.	!
■ After the electrical installation, should be energized for leakage detection. When thunder, please power off and unplug the power plug. Lightning shock may cause malfunction.	
■ Do not install the air conditioner in where the flammable gas may leak, to avoid fire hazard caused by gas leakage.	

Notices during Operation	
<ul style="list-style-type: none"> ■ Do not put flammable spray close to the air conditioner. Don't inject flammable spray towards the air conditioner, which may cause fire. 	
<ul style="list-style-type: none"> ■ Close the window to avoid outdoor air getting in. Curtains or window shutters can be put down to avoid the sunshine. 	
<ul style="list-style-type: none"> ■ Avoid the cold air blowing the body straightly for long time; Avoid setting the indoor temperature too low. Otherwise it may cause uncomfortable feel and be harmful to health. 	
<ul style="list-style-type: none"> ■ Do not run air conditioning when using smoked insecticide in the room. Otherwise the chemical substance may remain on the product which might endanger the health of highly allergic people. 	
<ul style="list-style-type: none"> ■ Cleaning of the air filter regularly, if the filter is blocked, it will cause the cooling and heating effect poor, power consumption increased, unit malfunction and cooling operation will drip. 	
<ul style="list-style-type: none"> ■ Power should be cut off when the air conditioner is left unused for a long period. Power will be consumed if the air conditioner is not powered off. The power switch of the outdoor unit switch should be powered on 12 hours in advance before operation to protect the unit after a long period of storage. 	
<ul style="list-style-type: none"> ■ The room should be ventilated regularly. After the use of air conditioning in the room for a long time, be sure to ventilate, to prevent air circulation does not cause physical discomfort. 	
<ul style="list-style-type: none"> ■ During the operation of the control unit, don't switch off the manual power switch and the controller can be used. Please do not press the liquid crystal zone of controller to prevent damage. 	
<ul style="list-style-type: none"> ■ Valuables and goods that must be kept dry can not be placed under the indoor unit. When the humidity exceeds 80% or the drain outlet is blocked, the indoor unit may drip and damage the goods. 	
<ul style="list-style-type: none"> ■ Plants and animals should not be put to the place where wind of the air conditioner blows directly, otherwise damage to them may be caused. 	
<ul style="list-style-type: none"> ■ It cannot be used for the preservation of food, living creature, precise instrument and artworks, etc, otherwise damage may occur. 	
<ul style="list-style-type: none"> ■ The distance between TV, radio, audio and other equipment and indoor unit should be more than 1m. Otherwise it will interfere the image and cause noise. 	
<ul style="list-style-type: none"> ■ 3-5minute protection To protect the unit, compressor can be actuated with at least 3-5minute delay after stopping. 	
<ul style="list-style-type: none"> ■ Defrosting during heating To improve the heating effect, the outdoor unit will perform defrosting automatically when frost appears on the outdoor unit during heating (approximately 2-10min). During defrosting, the fan of the indoor unit runs at a low speed or stops while that of the outdoor unit stops running. 	
<ul style="list-style-type: none"> ■ Stopping fan rotation The unit which stops operating will actuate the fan for a 2-8 min swing every 30-60 minutes for protecting the unit while other indoor unit are in the operating state. 	

1.9.3 Maintenance

⚠ Attention

- Repair can only be performed by professional personnel.
- Before touching the connection line, all power supplies should be switched off. Only after switching off the power supply can the operator clean the air conditioner as to avoid electric shock or injury.
- When cleaning the air cleaner, make sure to use a stable platform; don't flush the air conditioner with water, or the electric shock might be caused.

Daily Maintenance:

Clean the air cleaner & Inlet guide plate

- Don't dismantle the air cleaner if not cleaning, or faults might be caused.
- When the air conditioner operates in the environment with too much dust, clean the air conditioner more times (generally once every two weeks).

As shown in the drawing, draw the wind guide on both sides of the rack, with the thumb to hold down the screen two buttons down gently pull the other side of the filter from the bayonet can be removed.

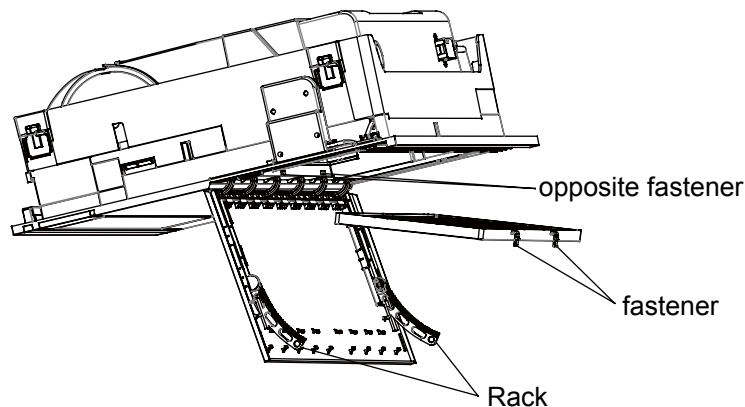

Clean the air cleaner

■ Cleaning

Clean the air cleaner with the dust collector or water to remove dusts.

For too much dust, use the fan or directly spray the special cookware detergent on the air inlet grid, and then clean it with water after 10 minutes.

(A) remove dust with dust collector.

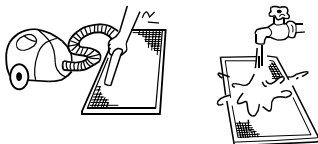

(B) for too much dust, use soft-hair brush and mild detergent to clean.

(C) throw off water and then dry it at cool places.

⚠ Attention

- Don't clean it with hot water of over 50°C to avoid fading or distortion.
- Don't dry it on the fire, or the cleaner might cause fire.

Install the air cleaner & Inlet guide plate

1. Install the air cleaner: The method is contrary to the method of removing the dust screen.
2. Install the Inlet guide plate: As shown below, the rack on the return air guide plate is inserted into the gear box.

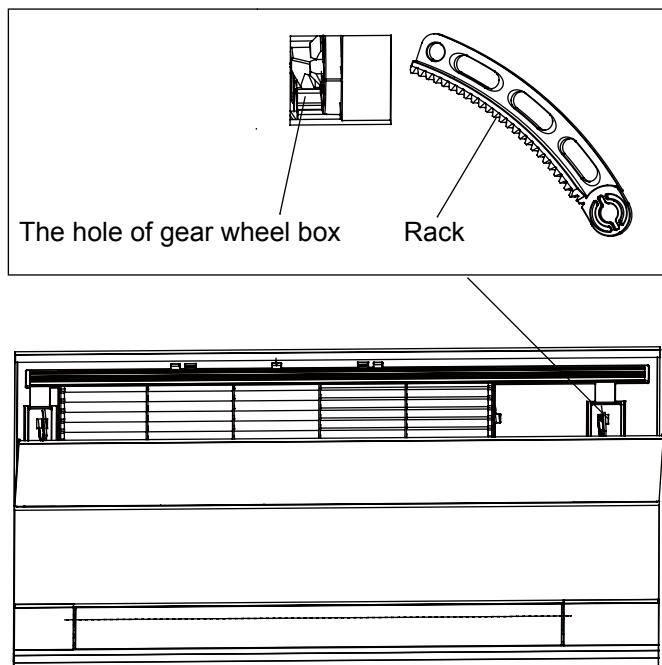

Cleaning the air outlet port and the shell

⚠ Attention

- Don't use gasoline, benzene, diluents, polishing powder or liquid insecticide to clean them.
- Do not clean them with hot water of above 50°C to avoid fading or distorting.
- Wipe them with soft dry cloth.
- Water or neutral dry cleanser is recommended if the dust cannot be removed.
- The Wind Deflector can be dismantled to clean.

⚠ Attention

- Do not wipe the wind deflector with water forcibly to avoid the floss falling off.

Maintenance before and after Operating Season

Before Operating Season:

1. Please make the following checkup:
 - There is no blockage in inlet port and outlet port of outdoor and indoor units.
 - The ground line and the wiring are in the proper state.
 If abnormal condition occurs, consult the after-service personnel.
2. Clean the air cleaner and the shell.
 - After cleaning, the air cleaner must be mounted.
3. Switch it on to the power.
 - After cleaning, the air cleaner must be mounted.

After Operating Season:

1. In sunny days, blowing operation can be performed for half a day to make the inside of machine dry.
2. Switch it off.
 - Electrical power should be cut down to economize electricity, or the machine will still consume power.
3. Clean the air cleaner and the shell.
 - Air cleaner and shell must be mounted after cleaning. For cleaning details, refer to Maintenance.

1.9.4 Fault checkup

Please check the following when consigning repair service:

	Symptoms	Reasons
All these are not problems	Water flow sound	Water flow sound can be heard when starting operation, during operation or immediately after stopping operation. When it starts to work for 2-3 minutes, the sound may become louder, which is the flowing sound of refrigerant or the draining sound of condensed water.
	Cracking sound	During operation, the air conditioner may make the cracking sound, which is caused from the temperature changes or the slight dilation of heat exchanger.
	Terrible smell in outlet air	The terrible smell, caused from walls, carpet, furniture, clothing, cigarette and cosmetics, attaches on the conditioner.
	Flashing operating indicator	When switching it on again after power failure, turn on the manual power switch and the operating indicator flashes.
	Awaiting indication	It displays the awaiting indication as it fails to perform refrigerating operation while other indoor units are in heating operation. When the operator set it to the refrigerating or heating mode and the operation is opposite to the setting, it displays the awaiting indication.
	Sound in shutdown indoor unit or white steam or cold air	To prevent oil and refrigerant from blocking the shutdown indoor units, refrigerant flows in the short time and make the sounds of refrigerant flowing. Otherwise, when other indoor units performs heating operation, white steam may occur; during refrigerating operation, cold air may appear.
	Clicking sound when switching the air condition on	When the conditioner is powered on, the sound is made due to the resetting of the expansion valve.
	Please make another check.	Start or stop working automatically
Failure to work 		Check if there is a power failure. Check if the manual power switch is turned off. Check if the supply fuse and breaker are disconnected. Check if the protective unit is working. Check if refrigerating and heating functions are selected simultaneously with the awaiting indication on line control.
Bad cooling & heating effects		Check if air intake port and air outlet port of outdoor units are blocked. Check if the door and windows are open. Check if the filtering screen of air cleaner is blocked with sludge or dust. Check if the setting of wind quantity is at low wind. Check if the setting of operation is at the Fan Operation state. Check if the temperature setting is proper.

Under the following circumstances, immediately stop the operation, disconnect the manual supply switch and contact the after-service personnel.

- When buttons are inflexible actuated;
- When fuse and breaker have been burnt over and over;
- When there are foreign objects and water in the refrigerator;
- When it cannot still be operated after removing the operation of protective unit;
- When other abnormal conditions occur.

1.9.5 Installation procedures

Before installation

- Do not throw away the included parts before installation.
- Determine the handling route from the unit to the installation location
- Before moving the unit to the installation position, do not remove the packaging, had to remove the packaging, with a soft material or protective plate with a rope to lift the unit, so as not to damage the unit or wipe scratches.
- After the unit is moved into the installation, please use the package to protect the unit from damage.

The standard attached accessories of the units of this series refer to the packing list; prepare other accessories according to the requirements of the local installation point of our company.

Indoor units should be installed in places with the environment of even circulation of cool and warm blows. The following places should be avoided.

- places with high salinity (beach), high sulfured gas (such as the thermal spring regions where copper tubes and soft soldering are easy to be eroded), much oil (including mechanical oil) and steam; places where organic substance solvent is used; where special spray is frequently used;
- places where machines generate the high frequency electromagnetic wave (abnormal condition will appear in the control system);
- places where there is high humidity exists near the door or windows (dew is easily formed).

Warning:

protect the machine from gales or earthquake, make the installation according to the regulations. Improper installation will cause accidents due to the overturn of the air conditioner.

1. Select the following places to install indoor units.

- (1) where there is enough room for the machine above the ceiling;
- (2) where the drainpipes can be well arranged;
- (3) where the distance between the air outlet port of the machine and the floor is not more than 2.7m;
- (4) where air inlet & outlet of the indoor units are not blocked;
- (5) where it is hard enough to bear the weight of the unit;
- (6) where there are no television, piano and other valuables under the indoor units as to avoid condensate dropping down, causing damage.
- (7) Where it is over 1m away from the television and radio as to avoid the disturbance from television and radio.
- (8) Select the indoor unit around (such as the ceiling of the installation of indoor units sandwich) dry bulb temperature below 30°C and relative humidity below 80% of the place. If the unit is running in a high humidity environment above the above conditions, there may be water drops. Please add 10 ~ 20mm insulation material (foamed polyethylene or equivalent) to the unit as well as piping and drain. When the insulation material exceeds 10mm, please press fit into the ceiling opening.
- (9) The indoor unit is not affected by external invasions. Return air is not recommended at the door, window, if there is no choice to keep closed, off the window, while saving energy can effectively reduce the air conditioning operation exception.

Installation Space

Ensure the required space for installation and maintenance (refer to the following drawings).

The installation height should be kept within 2.7m.

When the height of the ceiling exceeds 2.7m, the warm air is hard to blow to the ground.

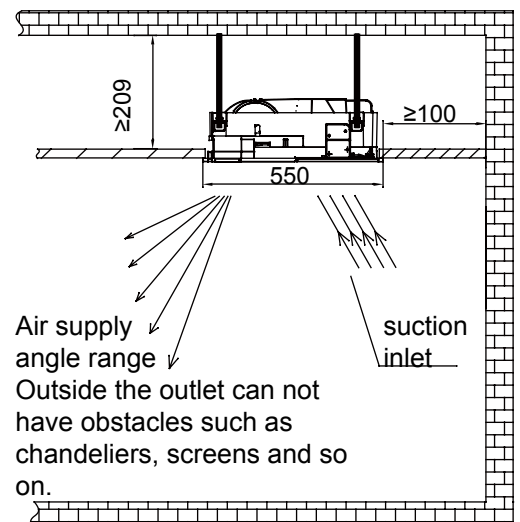
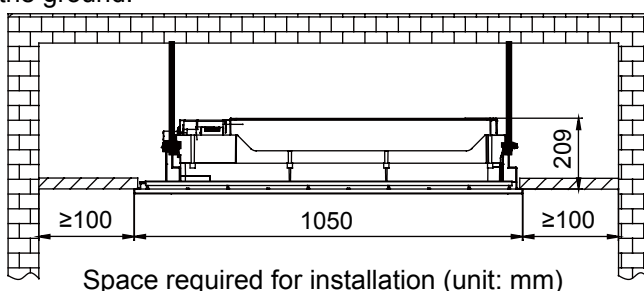

2. Location Relationship among Ceiling Hole, Unit and Hoisting Studs

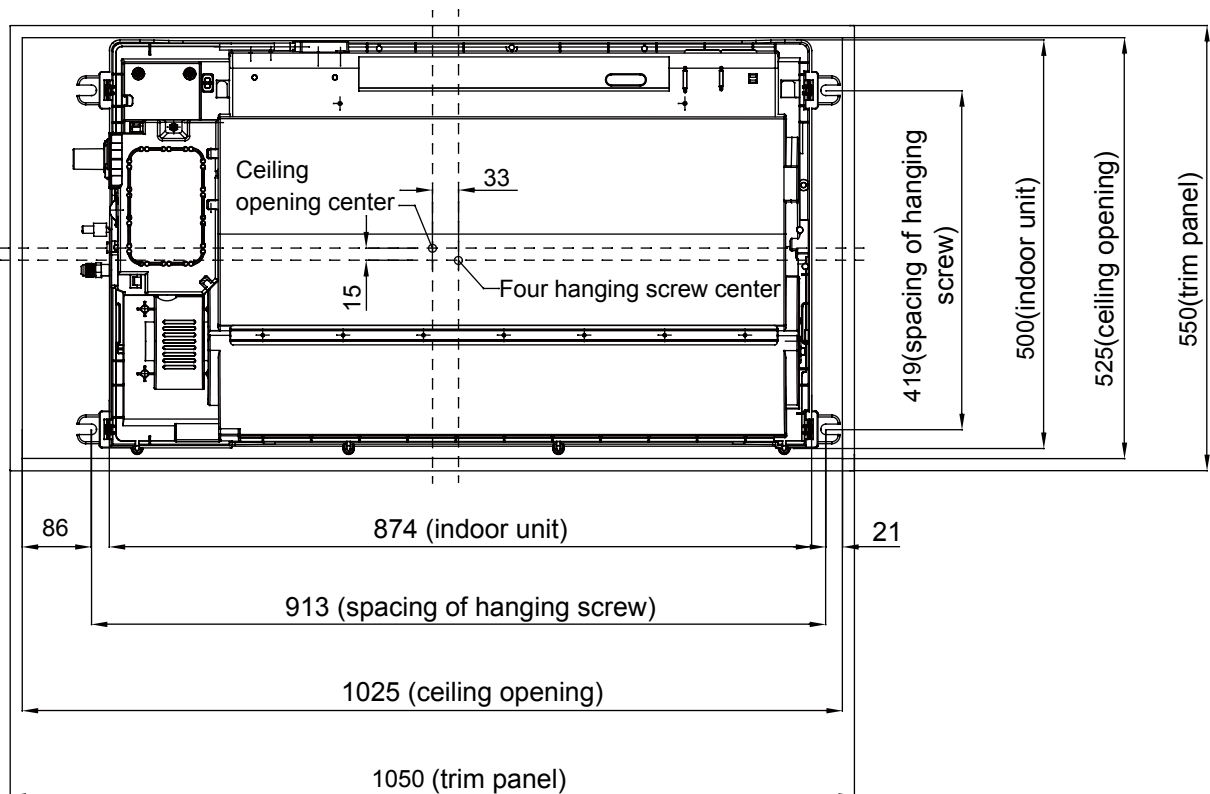

Note:

Before suspending the indoor unit, select the installation location according to the piping and wiring in the ceiling, and determine the lead direction of the piping. Prepare all pipes (refrigerator and drainage) and wiring (connection line for remote control and connection line of indoor units and outdoor units) connected to indoor units before suspending the indoor unit so as to make the connections right after the installation.

- In the situation with the ceiling, before suspending the unit, set refrigerant pipe, drainpipe, connection line in the room, lead wire of line control to the locations of piping and wiring.
- Confirm the size of the indoor unit and fix it according to the requirements in the manual.

3. Ceiling Hole & Reinforcement

- (1) Cut and withdraw the foundation of ceiling according to the size of indoor unit.
- (2) After cutting an appropriate hole, reinforce the cutting area on the foundation of indoor unit, and append the rim to the ceiling to secure its foundation. In order to prevent the ceiling from vibrating, it is vital to reinforce the ceiling foundation and ensure the original levelness of the ceiling.

4. Hoisting Stud Installation

- To support the weight of the unit, use barb bolts in the situation with the ceiling. In the situation with the new ceiling, use inlaid bolts, embedded bolts or other parts provided on site. Before proceeding the installation, adjust the gap between the bolts and the ceiling.
- Use four M10 hoisting studs (provided on site) (when the height of the hoisting stud exceeds 0.9m, M10 studs should be used.). The gaps should be kept according to the overall drawing of the air conditioner. Make the installation according to regulations for various building structures as to ensure the safety. Use the level meter to perform the parallel installation.

Ceiling Suspending

Situation with New Ceiling

- (1) Install the indoor unit temporarily:
attach the hoisting foot to hoisting stud. Make sure that nuts and washers should be used at two ends of the foot to secure the foot.
- (2) For the size of the ceiling hole, please refer to the schematic drawing at the previous page.
<After finishing the installation of the ceiling>
- (3) Adjust the unit to the proper installation location.
- (4) Check if the unit is in the horizontal level:
The indoor unit is equipped with a built-in drainage pump and a floater switch. Check if the 4 angles of the unit are in the horizontal level with the water level or the polythene tube with water, as shown in the figure, taking only one indoor unit as an example. If the unit inclines opposite to the direction of condensate flow, the floater switch might have faults, causing water dropping. (When lifting can be tilted to the drain, the long side of the horizontal height difference 0 ~ 10mm.)
- (5) Tighten the nut on the washer.
- (6) Remove the mounting cardboard.

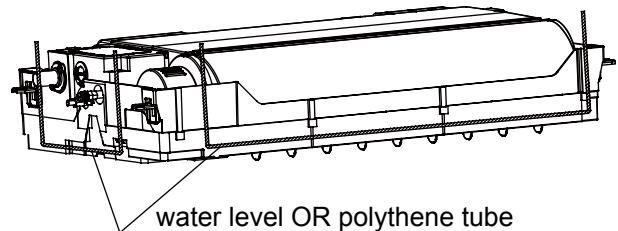

Situation with Original Ceiling

- (1) Install the indoor unit temporarily: attach the hoisting foot to hoisting stud. Make sure that nuts and washers (provided on site) should be used at two ends of the foot to secure the foot.
- (2) Adjust the height and location of the unit.
- (3) Perform Step 4 and 5 in Situation with New Ceiling.

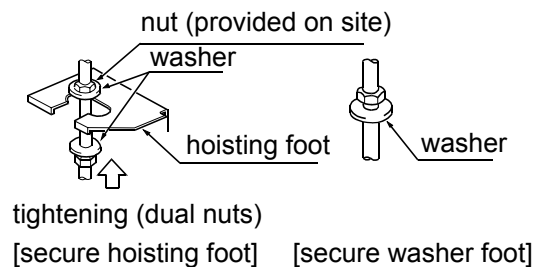

Preparation of Decorated Board

- Don't put the decorated board downward to the floor. Putting it against the wall or on the extrusive objects is not allowed.
- Don't touch the wind deflector or apply force on it, or the wind deflector will have faults.

- (1) Check the level of the indoor unit with a flat or filled polyethylene pipe and check that the size of the ceiling hole is correct. Remove the horizontal gauges before installing the trim panels.
- (2) Fix the screws so that the height difference between the two sides of the indoor unit is less than 5mm.

The installation of the decorative panel in the indoor unit body

- Install the panel before the need to remove the return air guide, the method at the same time hold down the two ends of the button, slowly even pull the guide plate, remove the appropriate place to prevent damage.
- Install the panel in the direction of the illustration to ensure that the panel inlet and outlet are corresponding to the inlet and outlet of the machine.

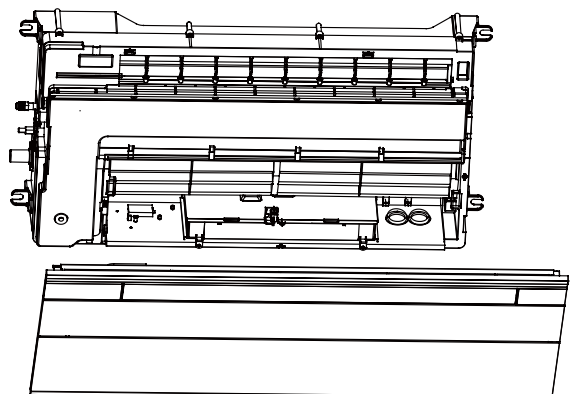

- Install the two claws into the snap and secure with the screws. (Screw hole position as shown, hidden parts have been hidden).

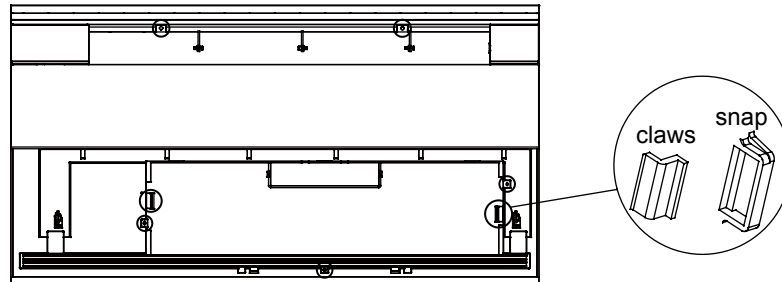

Decorative panels of the line

- Connect the connector on the right side of the trim panel to the stepped motor wire (10-pin)
- Connect the connector on the left side of the trim panel to the stepped motor wire (5-pin)
- Connect the connector of the lamp panel mounted on the trim panel (9-pin)
- Connect the communication cable, the power cord, and use the controller to check whether the connection is correct, make sure the machine can be installed after the normal operation of the filter, the return air guide back.

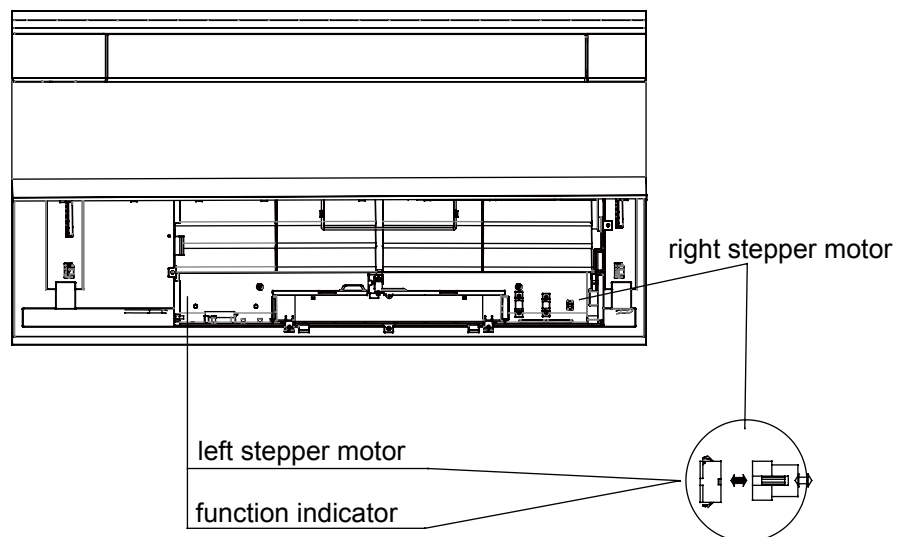

Caution:

- Improper tightening of bolts would lead to the faults shown in the following figure.

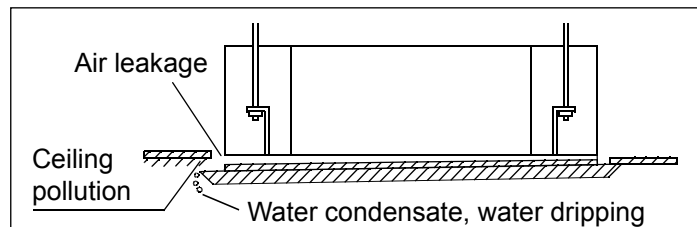

- After tightening the bolts, if there is a clearance between the ceiling and the trim panel, please readjust the height of the indoor unit.

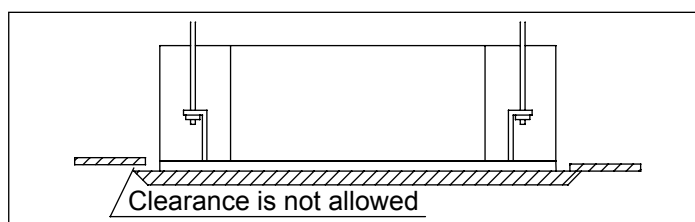

Drainpipes

Requirements:

- The drainpipe of the indoor unit should be heat-insulated.
- Heat insulation should be treated for the connection with the indoor unit. Improper heat insulation may cause condensing.
- The drainpipe with the down gradient of over 1/100 can't be in the S shape, or abnormal sound can be caused.
- The horizon length of the drainpipe should be kept with 20m. Under the condition of long pipes, supports can be provided every 1.5~2m as to avoid unevenness.
- The central piping should be connected according the following drawing.
- Take care not to apply external force on the connection of the drainpipes.

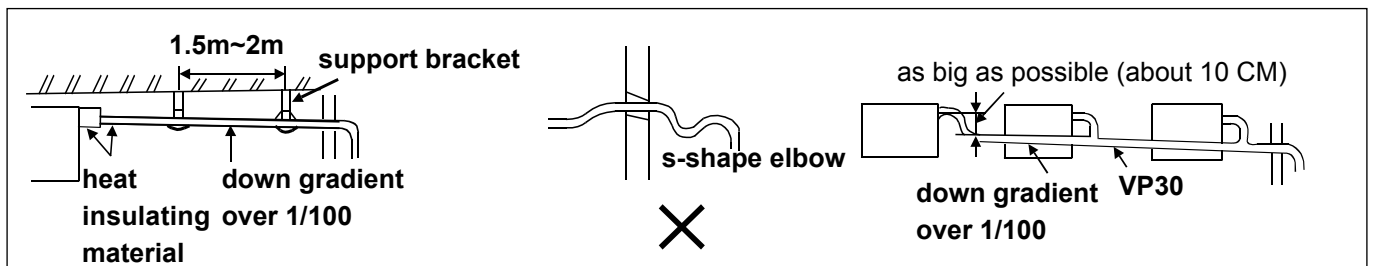

Piping Materials & Heat Insulating Materials

As to prevent condensation, heat insulating treatment should be performed. The heat insulating treatment for piping should be done respectively.

Piping Material	Hard PVC tube VP31.5mm (inner bore)
Heat Insulating Material	Vesicant polythene thickness: over 7mm

Hose

The attached hoses can be used to adjust the eccentricity and angle of the hard PVC tube.

- Stretch the hose directly to make connections as to avoid distortion. The soft end of the hose should be positioned with a clamp.

- The hose should be used in the horizon direction.

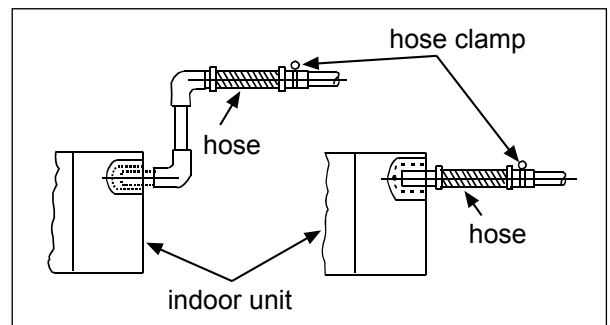
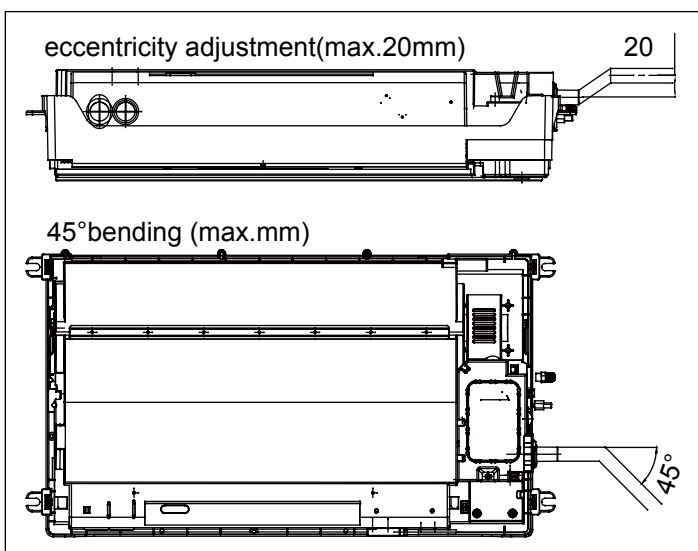

Heat Insulating Treatment:

- Wrap the connection between the clamp and the root segment of the indoor unit without any gap with heat insulating materials as shown in the drawing

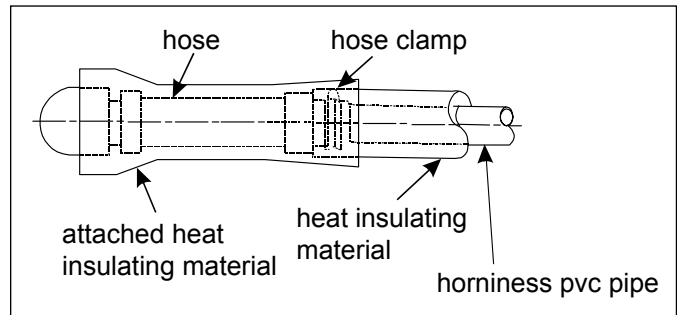

Lifting Drainpipe

The drainpipe can be lifted 450mm. When the down gradient of the drainpipe can't be ensured, after upright lifting, the drainpipe is in the down slope.

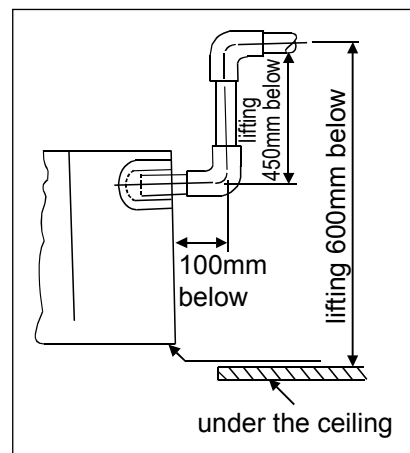

Confirming Drainage

The drainage should be confirmed during the test run to make sure that there is leakage at the connection. The confirmation of drainage should be also performed during the installation in the winter season.

- After mounting the electrical system, do cooling operation and meanwhile add water and check. Fill 600cc water with a hose from the injection nozzle. Add the water slowly. Don't add water to the motor of the drainage pump.

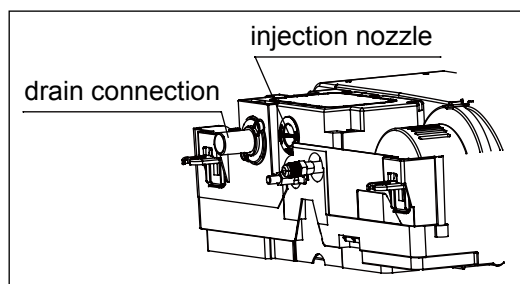

- Confirm the sound of the motor:
Confirm the sound of the motor of the drainage pump and meanwhile check the drainage.

Tubing Permissible Length & Height Difference

Please refer to the attached manual of outdoor units.

Tubing Materials & Specifications

Please refer to the attached manual of outdoor units.

Model	CVPA-025/022N-01M22	CVPA-035N-01M22
Tubing Size (mm)	Gas pipe	Ø9.52
	Liquid pipe	Ø6.35
Tubing Material	Phosphor deoxy bronze seamless pipe (TP2) for air conditioner	

Refrigerant Filling Amount

Add the refrigerant according to the installation instruction of outdoor unit. The addition of R410A refrigerant must be performed with a measure gage to ensure the specified amount while compressor failure can be caused by filling too much or little refrigerant.

Connecting Procedures of Refrigerant Tubing

Proceed the flare tube connecting operation to connect all the refrigerant tubes.

- Dual wrenches must be used in the connection of indoor unit tubing.
- Mounting torque refers to the right table

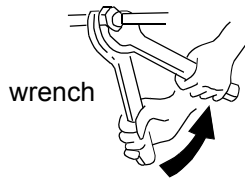

Outer Diameter of Tubing (mm)	Mounting Torque (N-m)	Increase mounting Torque (N-m)
Ø6.35	11.8(1.2kgf-m)	13.7(1.4kgf-m)
Ø9.52	24.5(2.5kgf-m)	29.4(3.0kgf-m)
Ø12.7	49.0(5.0kgf-m)	53.9(5.5kgf-m)
Ø15.88	78.4(8.0kgf-m)	98.0(10.0kgf-m)

Cutting and Enlarging

Cutting or enlarging pipes should be proceeded by installation personnel according to the operating criterion if the tube is too long or flare opening is broken.

Vacuumizing

Vacuumize from the stop valve of outdoor units with vacuum pump. Refrigerant sealed in indoor machine is not allowed to use for vacuumization.

Open All Valves

Open all the valves of outdoor units.

[NB: oil balancing stop valve must be shut up completely when connected one main unit.]

Checkup for Air Leakage

Check if there is any leakage at the connecting part and bonnet with hydrophone or soapsuds.

1.9.6 Electrical wiring

⚠ WARNING

- Electrical construction should be made with specific mains circuit by the qualified personnel according to the installation instruction. Electric shock and fire may be caused if the capacity of power supply is not sufficient.
- During arranging the wiring layout, specified cables should be used as the mains line, which accords with the local regulations on wiring. Connecting and fastening should be performed reliably to avoid the external force of cables from transmitting to the terminals. Improper connection or fastness may lead to burning or fire accidents.
- There must be the ground connection according to the criterion. Unreliable grounding may cause electrical shocks. Do not connect the grounding line to the gas pipe, water pipe, lightening rod and telephone line.

⚠ Attention

- Only copper wire can be used. Breaker for electric leakage should be provided, or electric shock may occur.
- The wiring of the mains line is of Y type. The power plug L should be connected to the live wire and plug N connected to null wire while PE should be connected to the ground wire. For the type with auxiliary electrically heating function, the live wire and the null wire should not be misconnected, or the surface of electrical heating body will be electrified. If the power line is damaged, replace it by the professional personnel of the manufacturer or service center.
- The power line of indoor units should be arranged according to the installation instruction of indoor units.
- The electrical wiring should be out of contact with the high-temperature sections of tubing as to avoid melting the insulating layer of cables, which may cause accidents.
- After connected to the terminal tier, the tubing should be curved into be a U-type elbow and fastened with the pressing clip.
- Controller wiring and refrigerant tubing can be arranged and fixed together.
- The machine can't be powered on before electrical operation. Maintenance should be done while the power is shut down.
- Seal the thread hole with heat insulating materials to avoid condensation.
- Signal line and power line are separately independent, which can't share one line. Signal line and power line spacing greater than 100mm.
- 5 butt lines (1.5mm) are equipped in the machine before delivery, which are used in connection between the valve box and the electrical system of the machine. The detailed connection is displayed in the circuit diagram.
- The power cord must go through the wire hole from the outside into the machine, the wire holes need to be sealed with rubber ring to prevent the wear of the power line insulation sheath; the use of the process should pay attention to the protection of the power cord. Prevent sharp objects from damaging the insulation of the power cord. Damage to the power cord may cause fever, fire and other accidents.

Connecting

1. Connecting circular terminals:

The connecting method of circular terminal is shown in the Fig. Take off the screw, connect it to the terminal tier after heading it through the ring at the end of the lead and then tighten it.

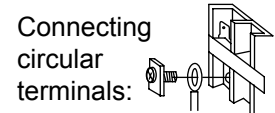

2. Connecting straight terminals:

The connection methods for the circular terminals are shown as follows: loosen the screw before putting the line terminal into the terminal tier, tighten the screw and confirm it has been clamped by pulling the line gently.

3. Pressing connecting line

After connecting line is completed, press the connecting line with clips which should press on the protective sleeve of the connecting line.

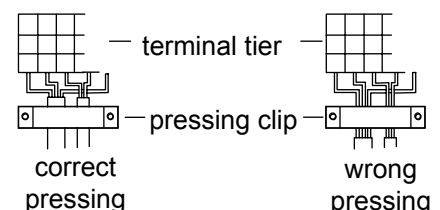

4. Electronic control box connection operation method

First, remove the screw of the fixed electric control box, pull out the electric control box, and then remove the electric control box cover fixing screw, take off the electric control box cover (both hands press and hold the button at the same time). Signal line through the machine through the hole, and then through the electronic control box hole into the box body, pay attention to the separation of strength. Connect the electric control box cover and push the electric control box back to the machine. Use screws to fix.

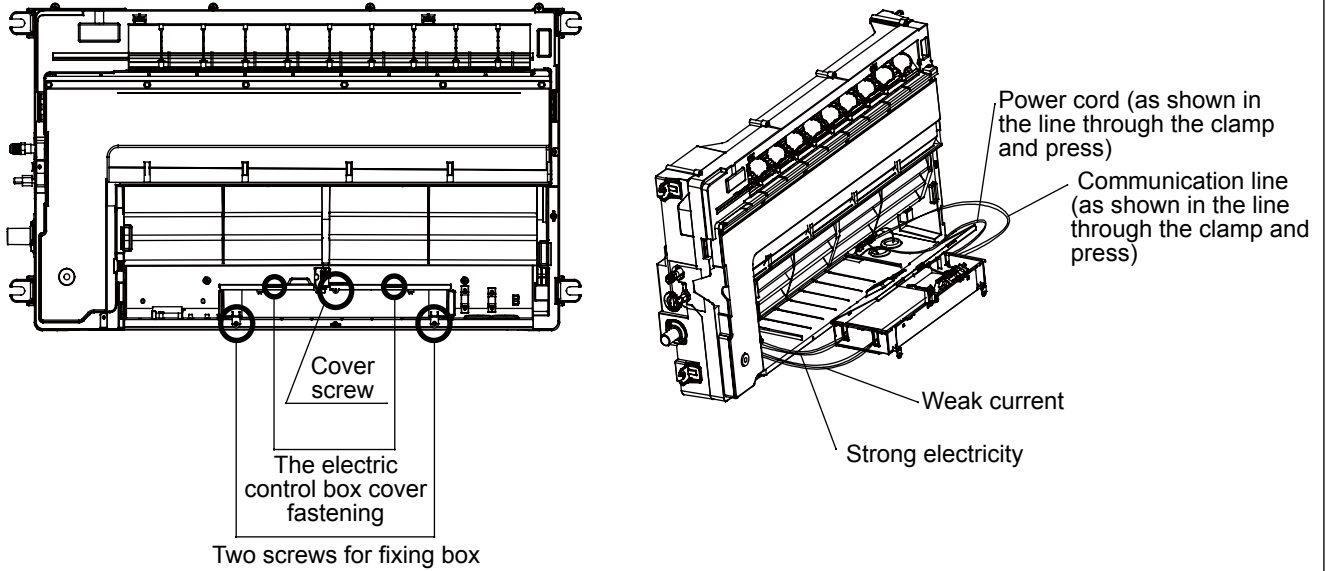

Supply Wiring Drawing

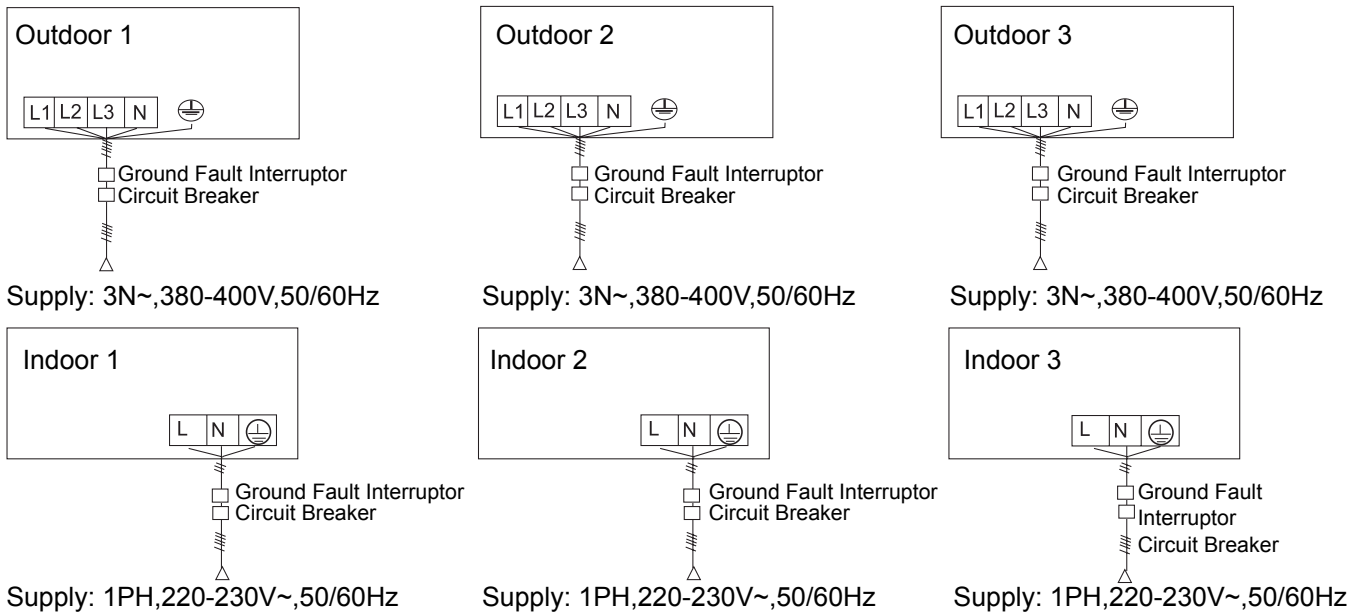

- Indoor units and outdoor units should be connected to the power source separately. Indoor units must share one single electrical source, but its capacity and specifications should be calculated. Indoor & outdoor units should be equipped with the power leakage breaker and the overflow breaker.

Signal Wiring Drawing

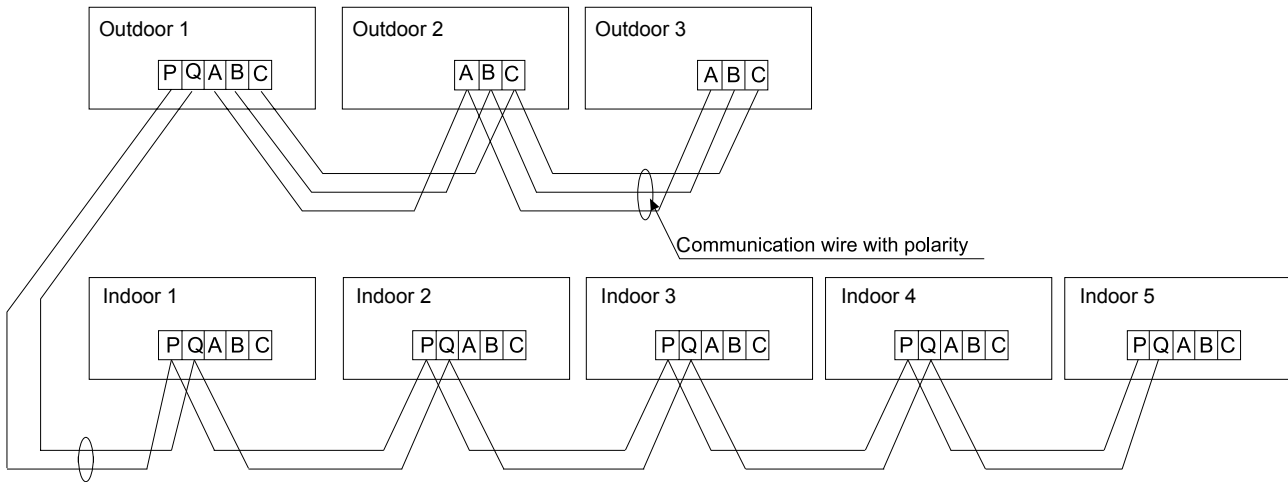

Outdoor units are of parallel connection via three lines with polarity. The master unit, central control and all indoor units are of parallel connection via two lines without polarity. The signal line between wired controller and indoor units are polarity

There are three connecting ways between wired controller and indoor units:

A. One wired controller controls one indoor unit, the wired controller connects with the ABC terminal of indoor unit.

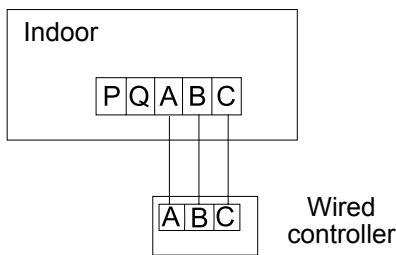

B. Two wired controllers control one indoor unit. Either of the wired controls can be set to be the master wired controller while the other is set to be the slave wired controller.

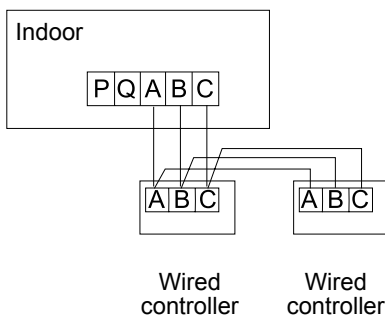

Master and slave controller setting method for RWV05, other controllers' setting method please refer to the controller manual

No.	Type	State of switch	Function description
SW1-1	Select the master or the slave controller	ON	Slave controller
		OFF	Master controller

C. One wired controller controls multiple units

0151800244BA PCB

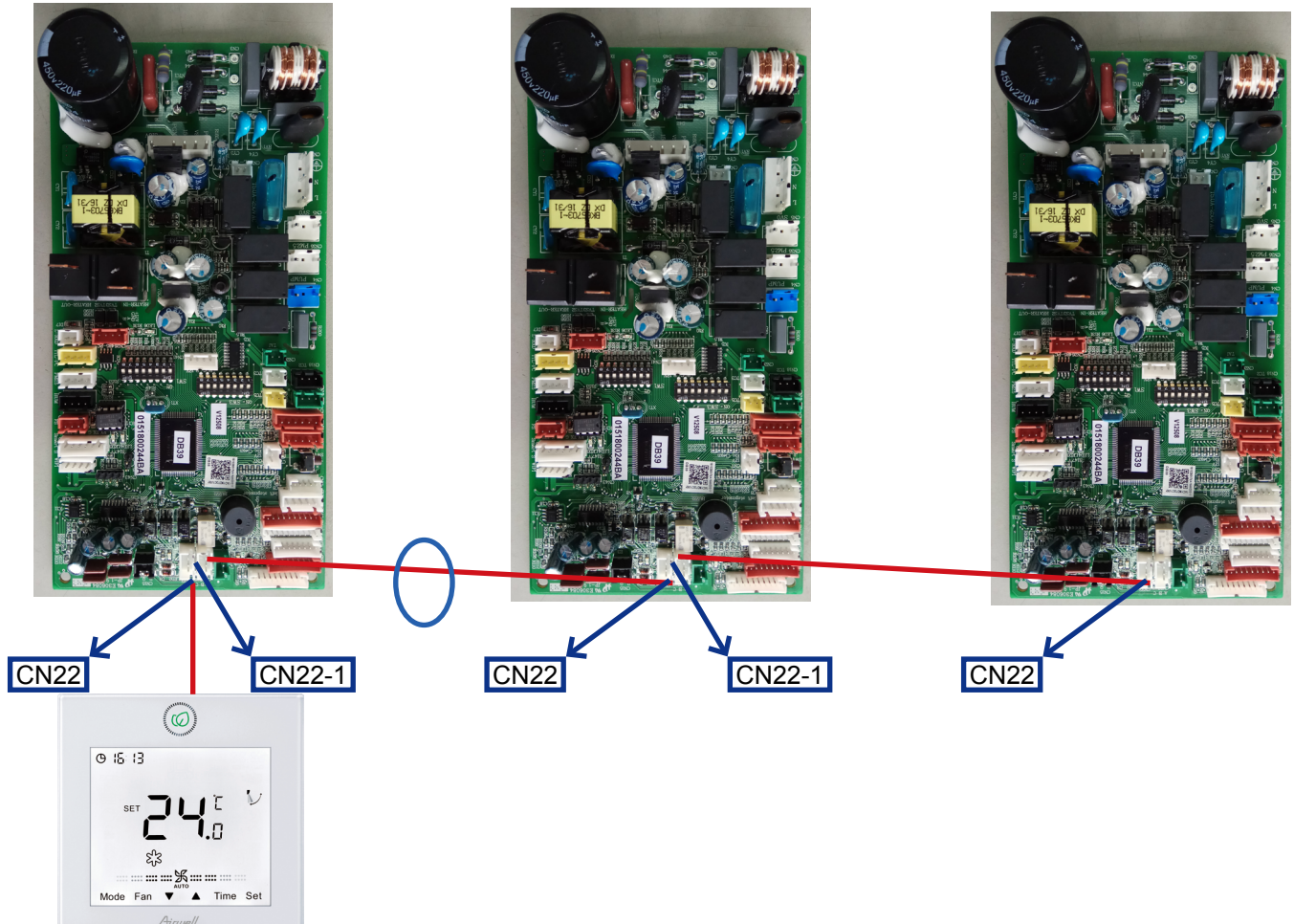

Note:

1. Plug the wired controller terminal to the CN22 terminal of master unit which wired address is 0.
2. The CN22-1 terminal of the previous unit is connected to the CN22 terminal of the next unit
3. Wired address setting

SW01_1 SW01_2 SW01_3 SW01_4	Wired control address	[1]	[2]	[3]	[4]	Wired control address
		OFF	OFF	OFF	OFF	OFF
		OFF	OFF	OFF	<u>ON</u>	Slave unit 1 in group control
		OFF	OFF	<u>ON</u>	OFF	Slave unit 2 in group control
		OFF	OFF	<u>ON</u>	<u>ON</u>	Slave unit 3 in group control
	
		<u>ON</u>	<u>ON</u>	<u>ON</u>	<u>ON</u>	Slave unit 15 in group control

4. One controller can Max. control 16 indoor units.
5. Hand-in-hand connection method
6. The signal line is polarity

The wiring for the power line of indoor unit, the wiring between indoor and outdoor units as well as the wiring between indoor units:

Items Total current of indoor units (A)	Cross section (mm ²)	Length (m)	Rated current of overflow breaker (A)	Rated current of residual circuit breaker (A) Ground fault Interrupter (mA) Response time (S)	Cross sectional area of signal Line	
					Outdoor -indoor (mm ²)	Indoor -indoor (mm ²)
<7	2.5	20	10	10 A, 30 mA, 0.1S or below	2 cores×(0.75-2.0) mm ² shielded line	
≥7 and <11	4	20	16	16 A, 30 mA, 0.1S or below		
≥11 and <16	6	25	20	20 A, 30 mA, 0.1S or below		
≥16 and <22	8	30	32	32 A, 30 mA, 0.1S or below		
≥22 and <27	10	40	32	32 A, 30 mA, 0.1S or below		

- The electrical power line and signal lines must be fastened tightly.
- Every indoor unit must have the ground connection.
- The power line should be enlarged if it exceeds the permissible length.
- Shielded lays of all the indoor and outdoor units should be connected together, with the shielded lay at the side of signal lines of outdoor units grounded at one point.
- It is not permissible if the whole length of signal line exceeds 1000m.

Signal wiring of wired controller

Length of signal line (m)	Wiring dimensions
≤ 250	0.75mm ² ×3 core shielded line

- ※ The shielding lay of the signal line must be grounded at one end.
- ※ The total length of the signal line shall not be more than 250m.

1.9.7 Test Run

Before Test Run

- Before switching it on, test the supply terminal tier (L, N terminals) and grounding points with 500V megaohm meter and check if the resistance is above 1MΩ. It can't be operated if it is below 1MΩ.
- Connect it to the power supply of outdoor units to energize the heating belt of the compressor. To protect the compressor at startup, power it on 12 hours prior to the operation.

Check if the arrangements of the drainpipe and connection line are correct.

The drainpipe shall be placed at the lower part while the connection line placed at the upper part. Heat preservation measures should be taken such as winding the drainpipe esp. in the indoor units with heating insulating materials. The drain pipe should be made a slope type to avoid protruding at the upper part and concaving at the lower part on the way.

Checkup of Installation

- | | |
|---|--|
| <input type="checkbox"/> check if the mains voltage is matching | <input type="checkbox"/> check if the installation place meets the requirement |
| <input type="checkbox"/> check if there is air leakage at the piping joints | <input type="checkbox"/> check if there is too much noise |
| <input type="checkbox"/> check if the connections of mains power and indoor & outdoor units are correct | <input type="checkbox"/> check if the connecting line is fastened |
| <input type="checkbox"/> check if the serial numbers of terminals are matching | <input type="checkbox"/> check if the connectors for tubing are heat insulated |
| | <input type="checkbox"/> check if the water is drained to the outside |
| | <input type="checkbox"/> check if the indoor units are positioned |

Ways of Test Run

Do ask the installation personnel to make a test run. Take the testing procedures according to the manual and check if the temperature regulator works properly.

When the machine fails to start due to the room temperature, the following procedures can be taken to do the compulsive running. The function is not provided for the type with remote control.

- Set the wired controller to cooling/heating mode, press "ON/OFF" button for 5 seconds to enter into the compulsive cooling/heating mode. Repress "ON/OFF" button to quit the compulsive running and stop the operation of the air conditioner.

Airwell

Just feel well

WARNING :

The design and specifications are subject to change without prior notice for product improvement. Consult with the sales agency or manufacturer for details.

ATTENTION :

Le design et les données techniques sont donnés à titre indicatif et peuvent être modifiés sans préavis.



AIRWELL RESIDENTIAL SAS

10,Rue du Fort de Saint Cyr,
78180 Montigny le Bretonneux - France
www.airwell.com