

Airwell

Just feel well

TECHNICAL Manual

MIDDLE STATIC PRESSURE DUCT AIR CONDITIONER
DFMA R410A ON OFF 50Hz
English Manual

DFMD-100N-01M25 / YFAD-100R-01M25
DFMD-100N-01T35 / YFAD-100R-01T35
DFMD-140N-01M25 / YFAD-140R-01M25
DFMD-160N-01M25 / YFAD-160R-01M25

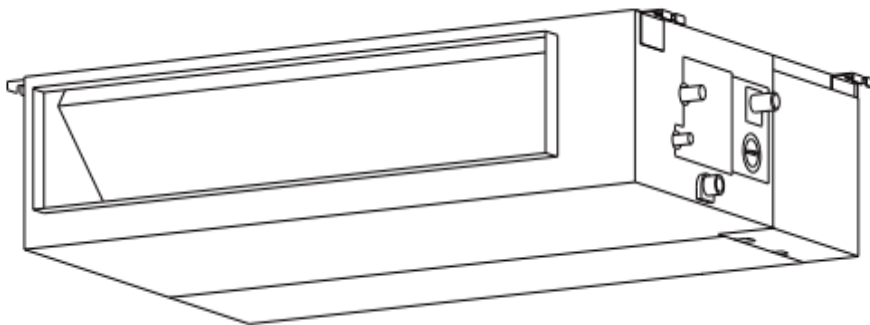

IMPORTANT NOTE:

Read this manual carefully before installing or operating your new air conditioning unit. Make sure to save this manual for future reference.

21.AW.DFMD.100-160.R410A.TM.EN.11.19.Rev01

Table of Contents

Page

1. Specifications	4
1. Model Reference	
2. General Specifications	
3. Dimensional Drawings	
4. Centre of Gravity	
5. Electrical Wiring Diagrams	
6. Refrigerant Cycle Diagrams	
7. Capacity Tables	
8. Capacity Correction Factor for Height Difference	
9. Noise Data	
10. Electrical Characteristics	
11. Static Pressure	
2. Product Features	58
1. Operation Modes and Functions	
2. Remote Controller Functions	
3. Installation	75
1. Installation Overview	
2. Location Selection	
3. Indoor Unit Installation	
4. Outdoor Unit Installation	
5. Drainage Pipe Installation	
6. Refrigerant Pipe Installation	
7. Vacuum Drying and Leakage checking	
8. Additional Refrigerant Charge	
9. Engineering of Insulation	
10. Engineering of Electrical Wiring	
11. Test Operation	

4. Static Pressure Design	91
1. Introduction	
2. Charts for friction losses in round ducts	
3. Dynamic losses	
4. Corresponding relation between Rectangular duct and Round duct	
5. Method for duct calculation	
6. Unit conversion	
7. Recommended outlet velocity for different occasions	

Specifications

Contents

1.	Model Reference.....	5
2.	General Specifications.....	6
3.	Dimensional Drawings.....	12
4.	Centre of Gravity.....	15
5.	Electrical Wiring Diagrams.....	18
6.	Refrigerant Cycle Diagrams.....	31
7.	Capacity Tables.....	33
8.	Capacity Correction Factor for Height Difference.....	48
9.	Noise Data.....	53
10.	Electrical Characteristics.....	55
11.	Static Pressure.....	56

1. Model Reference

Refer to the following table to determine the specific indoor and outdoor unit model number of your purchased equipment.

Indoor Unit Model	Outdoor Unit Model	Capacity (Btu/h)	Power Supply
DFMD-100N-01M25	YFAD-100R-01M25	36K	1 Φ , 220~240V~, 50Hz
DFMD-100N-01T35	YFAD-100R-01T35	36K	3 Φ , 380~415V~, 50Hz
DFMD-140N-01M25	YFAD-140R-01M25	48K	3 Φ , 380~415V~, 50Hz
DFMD-160N-01M25	YFAD-160R-01M25	60K	3 Φ , 380~415V~, 50Hz

2. General Specifications

Indoor model		DFMD-100N-01T35			
Outdoor model		YFAD-100R-01T35			
Power Supply		V-Ph-Hz	220-240,50,1		
Max. input consumption		W	5200		
Max. input current		A	23.0		
Indoor fan motor	Model		YKSS-115-4-21		
	Qty		1		
	Insulation class		F		
	IP rating		IPX0		
	Input		W	253.0	
	Capacitor		uF	5	
	Speed(Hi/Mi/Lo)		r/min	1110/1000/910/780	
Indoor coil	Number of rows		3		
	Tube pitch(a)x row pitch(b)		mm	21x13.37	
	Fin spacing		mm	1.4	
	Fin type (code)		Hydrophilic aluminium		
	Tube outside dia.and type		mm	Φ7, innergroove tube	
	Coil length x height x width		mm	915x294x40.11	
	Number of circuits		7		
ESP	Rated		Pa	37	
	Range		Pa	0-100	
Indoor air flow (Hi/Mi/Lo)		m ³ /h	1700/1280/950		
Sound level (sound pressure)		dB(A)	45/41.5/38.5		
Throttle type		/			
Indoor unit	Dimension(W*D*H)		mm	1100x774x249	
	Packing (W*D*H)		mm	1305x805x305	
	Net/Gross weight		Kg	33.2/40.3	
Design pressure		MPa	4.2/1.5		
Drainage water pipe diameter		mm	ODΦ25mm		
Refrigerant piping	Liquid side/ Gas side		mm(inch)	Φ9.52/Φ19(3/8"/3/4")	
Controller		wired control			
Operation temperature		C	17~30		
Room temperature	Cooling		C	17~32	
	Heating		C	0~30	
Qty/per 20' /40' /40'HQ		Indoor unit	77/161/198		
Compressor	Model		ATQ420V1SMT		
	Type		ROTARY		
	Brand		GMCC		
	Capacity		W	10435/10525	
	Input		W	3520/3755	
	Rated current(RLA)		A	16.35/17.25	
	Locked rotor Amp(LRA)		A	89	
	Thermal protector position		INTERNAL		
	Capacitor		μF	45UF/450V	
	Refrigerant oil/oil charge		ml	ESTER OIL VG75 · 1250±15-ml	

Outdoor fan motor	Model		YKS-190-6-21L
	Qty		1
	Insulation class		B
	IP rating		IPX4
	Input	W	293.3
	Capacitor	uF	10/450V
	Speed	r/min	850/770
Outdoor coil	Number of rows		2
	Tube pitch(a)x row pitch(b)	mm	25.4x22
	Fin spacing	mm	1.3
	Fin type (code)		Hydrophilic aluminum
	Tube outside dia.and type	mm	Φ9.52,Inner groove tube
	Coil length x height x width	mm	995x762x44
	Number of circuits		4
Outdoor noise level		dB(A)	63
Throttle type			Throttle valve
Outdoor unit	Dimension(W*D*H)	mm	946x410x810
	Packing (W*D*H)	mm	1090x500x885
	Net/Gross weight	Kg	75.6/80.4
Refrigerant type	Type		R410A
	Charged volume	Kg	2.8
Design pressure		MPa	4.2/1.5
Refrigerant piping	Liquid side/ Gas side	mm(inch)	Φ9.52/Φ19(3/8"/3/4")
	Max. refrigerant pipe length	m	30
	Max. difference in level	m	20
Room temperature	Cooling	C	18-43
	Heating	C	-7-24
Qty/per 20' /40' /40'HQ		Outdoor unit	44/96/138

Notes:

1) Capacities are based on the following conditions:

Cooling(T1): - Indoor Temperature 27°C(80.6°F) DB /19 °C(66.2°F) WB Heating: - Indoor Temperature 20°C(68°F) DB / 15°C(59°F) WB
 -Outdoor Temperature 35 °C(95°F) DB /24 °C(75.2°F) WB -Outdoor Temperature 7°C(44.6°F) DB / 6°C(42.8°F) WB
 -Interconnecting Piping Length 5m - Interconnecting Piping Length 5 m
 - Level Difference of Zero. - Level Difference of Zero.

2) Capacities are Net Capacities.

3) Due to our policy of innovation some specifications may be changed without notification.

Indoor model			DFMD-100N-01T35	DFMD-140N-01M25
Outdoor model			YFAD-100R-01T35	YFAD-140R-01T35
Power Supply		V-Ph-Hz	380~415,50,3	380~415,50,3
Max. input consumption		W	4250	6300
Max. input current		A	7	11
Indoor fan motor	Model		YKSS-115-4-21	YKSS-210-4-2
	Qty		1	1
	Insulation class		F	B
	IP rating		IPX0	IPX0
	Input	W	253	430
	Capacitor	uF	8	10
	Speed(Hi/Mi/Lo)	r/min	1110/1000/910/780	930/860/760
Indoor coil	Number of rows		3	3
	Tube pitch(a)x row pitch(b)	mm	21x13.37	21x13.37
	Fin spacing	mm	1.4	1.3
	Fin type (code)		Hydrophilic aluminium	Hydrophilic aluminium
	Tube outside dia.and type	mm	Φ7, innergroove tube	Φ7,innergroove tube
	Coil length x height x width	mm	915x294x40.11	1030x378x40.11
	Number of circuits		7	8
ESP	Rated	Pa	37	50
	Range	Pa	0-100	0-160
Indoor air flow (Hi/Mi/Lo)		m3/h	1804/1372/1149	2150/1800/1400
Sound level (sound pressure)		dB(A)	47/40.5/38	48.5/45/41
Throttle type			/	/
Indoor unit	Dimension(W*D*H)	mm	1100x774x249	1200x874x300
	Packing (W*D*H)	mm	1305x805x315	1405x915x365
	Net/Gross weight	Kg	32.2/39.4	46/54.5
Design pressure		MPa	4.2/1.5	4.2/1.5
Drainage water pipe diameter		mm	ODΦ25mm	ODΦ25mm
Refrigerant piping	Liquid side/ Gas side	mm(inch)	Φ9.52/Φ19(3/8"/3/4")	Φ9.52/Φ19(3/8"/3/4")
Controller			wired control	wired control
Operation temperature		C	17~30	17~30
Room temperature	Cooling	C	17~32	17~32
	Heating	C	0~30	0~30
Qty'per 20' /40' /40'HQ		Indoor unit	77/161/184	62/130/149
Compressor	Model		ATQ420Y1TMT	C-SBN373H8D
	Type		ROTARY	Scroll
	Brand		GMCC	Panasonic
	Capacity	W	10460W±5%	14100/17100
	Input	W	3430W±5%	4750/5600
	Rated current(RLA)	A	6.1A±5%	8.22/8.30
	Locked rotor Amp(LRA)	A	36	66.0
	Thermal protector position		INTERNAL	Internal
	Capacitor	μF	/	/
	Refrigerant oil/oil charge	ml	ESTER OIL VG74 1200CC	FV68S/1700
Outdoor fan motor	Model		YKS-190-6-21L	YKT-65-6-34L
	Qty		1	2
	Insulation class		B	B
	IP rating		IPX4	IPX4
	Input	W	293.3	162
	Capacitor	uF	10/450V	3.5UF/450V
	Speed	r/min	850/770	765

Outdoor coil	Number of rows		2.0	2.0
	Tube pitch(a)x row pitch(b)	mm	25.4x22	22x19.05
	Fin spacing	mm	1.3	1.6
	Fin type (code)		Hydrophilic aluminum	Hydrophilic aluminum
	Tube outside dia.and type	mm	Φ9.52,Inner groove tube	Φ7.94,Inner groove tube
	Coil length x height x width	mm	995x762x44	837x1100x38.1
	Number of circuits		4	8
Outdoor noise level		dB(A)	63	63
Throttle type			Throttle valve	Throttle valve
Outdoor unit	Dimension(W*D*H)	mm	946x410x810	900x350x1170
	Packing (W*D*H)	mm	1090x500x875	1032x443x1307
	Net/Gross weight	Kg	74.4/78.9	97/107
Refrigerant type	Type		R410A	R410A
	Charged volume	Kg	2.85	3.3
Design pressure		MPa	4.2/1.5	4.2/1.5
Refrigerant piping	Liquid side/ Gas side	mm(inch)	Φ9.52/Φ19(3/8"/3/4")	Φ9.52/Φ19(3/8"/3/4")
	Max. refrigerant pipe length	m	30	50
	Max. difference in level	m	20	30
Room temperature	Cooling	C	18-43	18-43
	Heating	C	-7-24	-7-24
Qty'per 20' /40' /40'HQ		Outdoor unit	44/96/144	27/57/108

Notes:

1) Capacities are based on the following conditions:

Cooling(T1): - Indoor Temperature 27°C(80.6°F) DB /19 °C(66.2°F) WB Heating: - Indoor Temperature 20°C(68°F) DB / 15°C(59°F) WB
 -Outdoor Temperature 35 °C(95°F) DB /24 °C(75.2°F) WB -Outdoor Temperature 7°C(44.6°F) DB / 6°C(42.8°F) WB
 -Interconnecting Piping Length 5m - Interconnecting Piping Length 5 m
 - Level Difference of Zero. - Level Difference of Zero.

2) Capacities are Net Capacities.

3) Due to our policy of innovation some specifications may be changed without notification.

Indoor model		DFMD-160N-01M25	
Outdoor model		YFAD-160R-01T35	
Power Supply		V-Ph-Hz	380-415,50,3
Max. input consumption		W	7500
Max. input current		A	12.6
Indoor fan motor	Model		YKSS-210-4-2
	Qty		1
	Insulation class		B
	IP rating		IPX0
	Input	W	430
	Capacitor	uF	10
	Speed(Hi/Mi/Lo)	r/min	930/860/760
Indoor coil	Number of rows		3
	Tube pitch(a)x row pitch(b)	mm	21x13.37
	Fin spacing	mm	1.3
	Fin type (code)		Hydrophilic aluminium
	Tube outside dia.and type	mm	Φ7,innergroove tube
	Coil length x height x width	mm	1030x378x40.11
	Number of circuits		8
ESP	Rated	Pa	50
	Range	Pa	0-160
Indoor air flow (Hi/Mi/Lo)		m3/h	2400/1850/1490
Sound level (sound pressure)		dB(A)	51.7/46.9/44.4
Throttle type			/
Indoor unit	Dimension(W*D*H)	mm	1200x874x300
	Packing (W*D*H)	mm	1405x915x365
	Net/Gross weight	Kg	46/54.5
Design pressure		MPa	4.2/1.5
Drainage water pipe diameter		mm	ODΦ25mm
Refrigerant piping	Liquid side/ Gas side	mm(inch)	Φ9.52/Φ19(3/8"/3/4")
Controller			wired control
Operation temperature		C	17-30
Room temperature	Cooling	C	17-32
	Heating	C	0-30
Qty'per 20' /40' /40'HQ		Indoor unit	62/130/149
Compressor	Model		C-SBN453H8D
	Type		Scroll
	Brand		Panasonic
	Capacity	W	16400/20300
	Input	W	5750/6750
	Rated current(RLA)	A	9.77/9.84
	Locked rotor Amp(LRA)	A	63/68
	Thermal protector position		Internal
	Capacitor	uF	/
	Refrigerant oil/oil charge	ml	FV68S/1700
Outdoor fan motor	Model		YKT-65-6-34L
	Qty		2
	Insulation class		B
	IP rating		IPX4
	Input	W	162
	Capacitor	uF	3.5UF/450V
	Speed	r/min	765

Outdoor coil	Number of rows		2
	Tube pitch(a)x row pitch(b)	mm	21x22
	Fin spacing	mm	1.3
	Fin type (code)		Hydrophilic aluminum
	Tube outside dia.and type	mm	Φ7,Inner groove tube
	Coil length x height x width	mm	830*22*630+795*22*630+830*22*483+795*22*483
	Number of circuits		8+4
Outdoor noise level		dB(A)	62.8
Throttle type			Throttle valve
Outdoor unit	Dimension(W*D*H)	mm	900x350x1170
	Packing (W*D*H)	mm	1032x443x1307
	Net/Gross weight	Kg	99.7/111.2
Refrigerant type	Type		R410A
	Charged volume	Kg	3.3
Design pressure		MPa	4.2/1.5
Refrigerant piping	Liquid side/ Gas side	mm(inch)	Φ9.52/Φ19(3/8"/3/4")
	Max. refrigerant pipe length	m	50
	Max. difference in level	m	30
Room temperature	Cooling	C	18-43
	Heating	C	-7-24
Qty'per 20' /40' /40'HQ		Outdoor unit	27/57/108

Notes:

1) Capacities are based on the following conditions:

Cooling(T1): - Indoor Temperature 27°C(80.6°F) DB /19 °C(66.2°F) WB Heating: - Indoor Temperature 20°C(68°F) DB / 15°C(59°F) WB
 -Outdoor Temperature 35 °C(95°F) DB /24 °C(75.2°F) WB -Outdoor Temperature 7°C(44.6°F) DB / 6°C(42.8°F) WB
 -Interconnecting Piping Length 5m - Interconnecting Piping Length 5 m
 - Level Difference of Zero. - Level Difference of Zero.

2) Capacities are Net Capacities.

3) Due to our policy of innovation some specifications may be changed without notification.

3. Dimensional Drawings

3.1 Indoor Unit

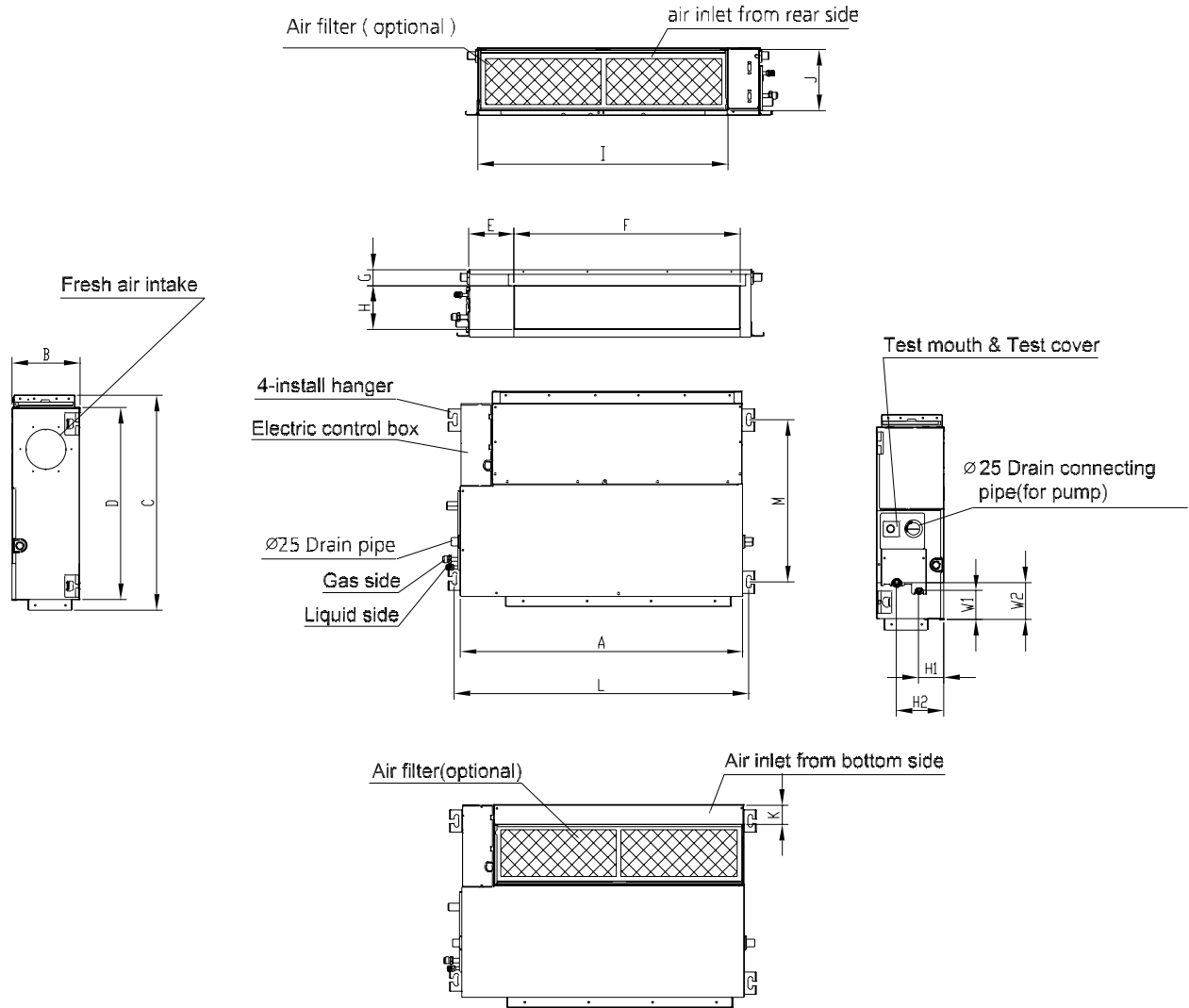

Model	unit	A	B	C	D	E	F	G	H	I	J	K	L	M	H1	H2	W1	W2
18	mm	880	210	674	600	140	706	50	136	782	190	40	920	508	78	148	88	112
	inch	34.65	8.27	26.54	25.98	5.51	27.80	1.97	5.35	30.79	7.48	1.57	36.22	20	3.07	5.83	3.46	4.41
24-36	mm	1100	249	774	700	140	926	50	175	1001	228	5	1140	598	80	150	130	155
	inch	43.31	9.80	30.47	27.56	5.51	36.46	1.97	6.89	39.41	8.98	0.2	44.88	11.73	3.15	5.91	5.12	6.10
48-60	mm	1200	300	874	800	123	1044	50	227	1101	280	5	1240	697	80	150	185	210
	inch	47.24	11.81	34.41	31.5	4.84	41.1	1.97	8.94	43.35	11.02	0.2	48.82	27.44	3.15	5.91	7.28	8.27

3.2 Outdoor Unit

Single Fan Outdoor Unit

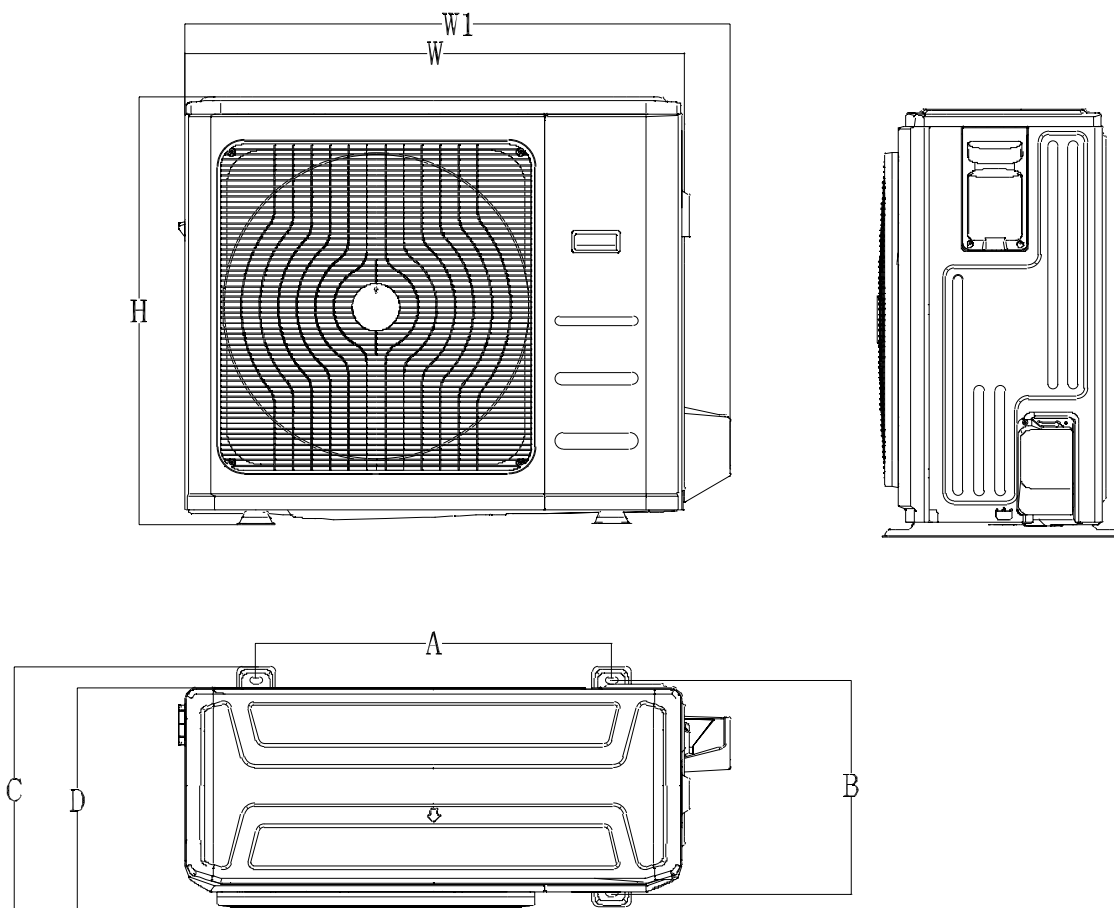

Model(KBtu/h)	unit	W	D	H	W1	A	B
18	mm	770	300	555	840	487	298
	inch	30.31	11.81	21.85	33.07	19.17	11.73
24	mm	845	363	702	914	540	350
	inch	33.27	14.29	27.64	35.98	21.26	13.78
36	mm	946	410	810	1030	673	403
	inch	37.24	16.14	31.89	40.55	26.50	15.87

Double Fan Outdoor Unit

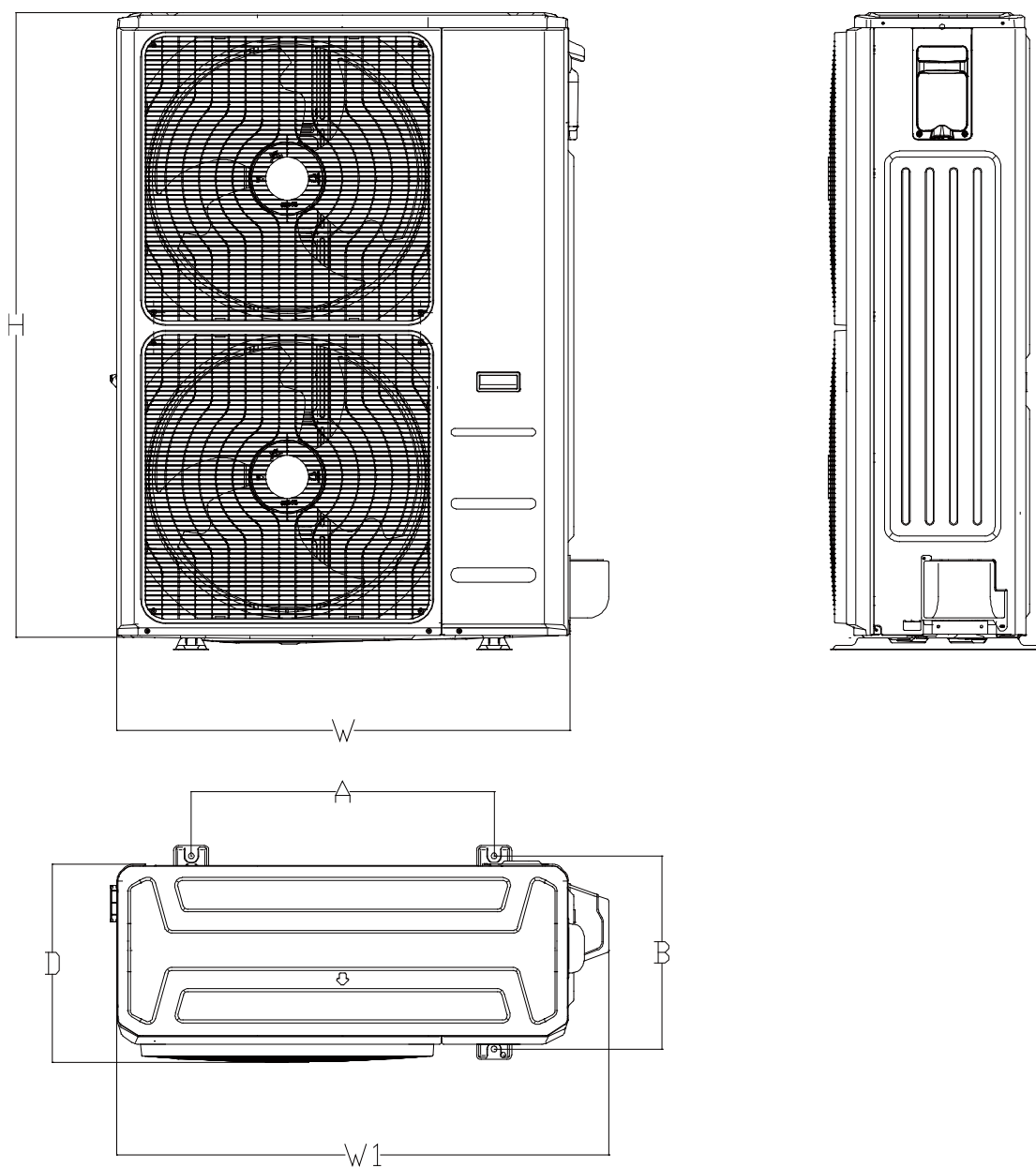

Model (KBtu/h)	unit	W	D	H	W1	A	B
48/60	mm	900	350	1170	985	590	378
	inch	35.43	13.78	46.06	38.78	23.23	14.88

4. Centre of gravity

18K

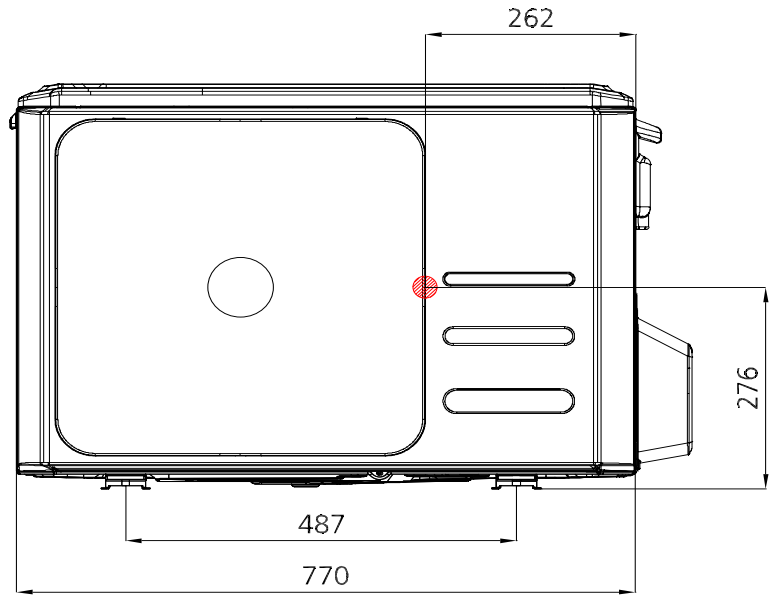
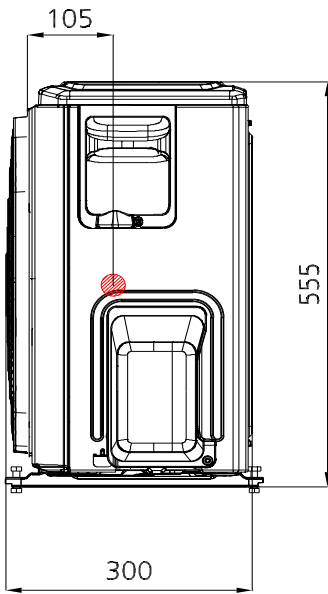

24K

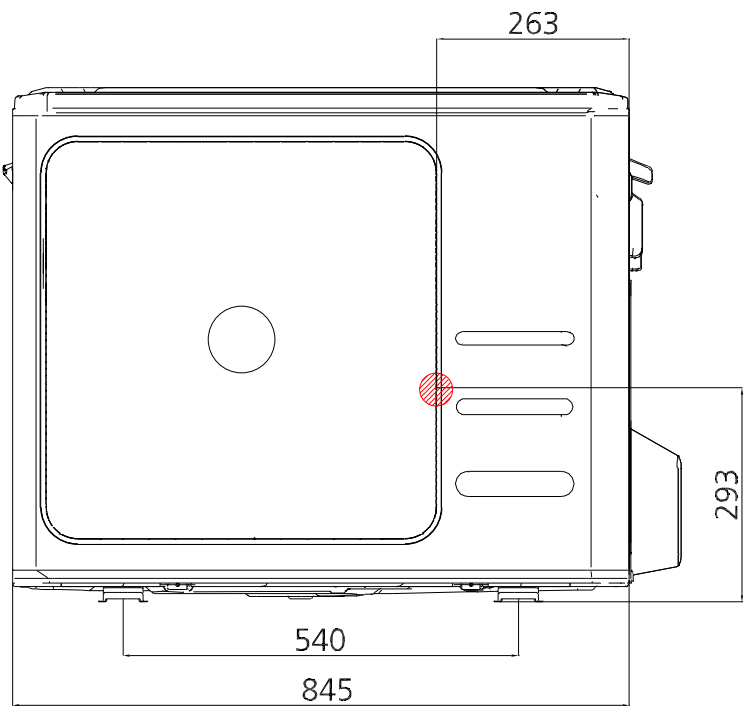
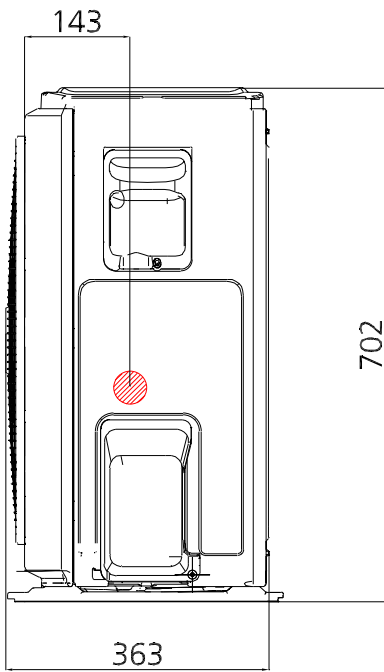

36K

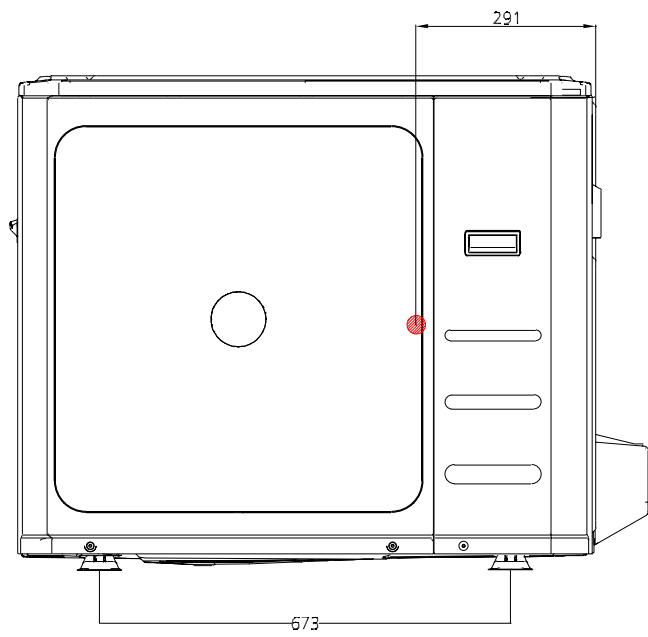
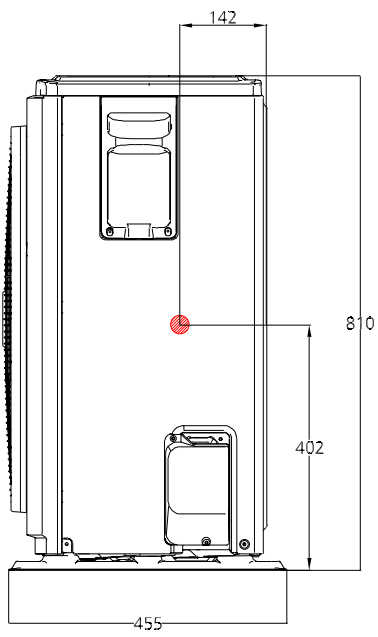

48K, 60K

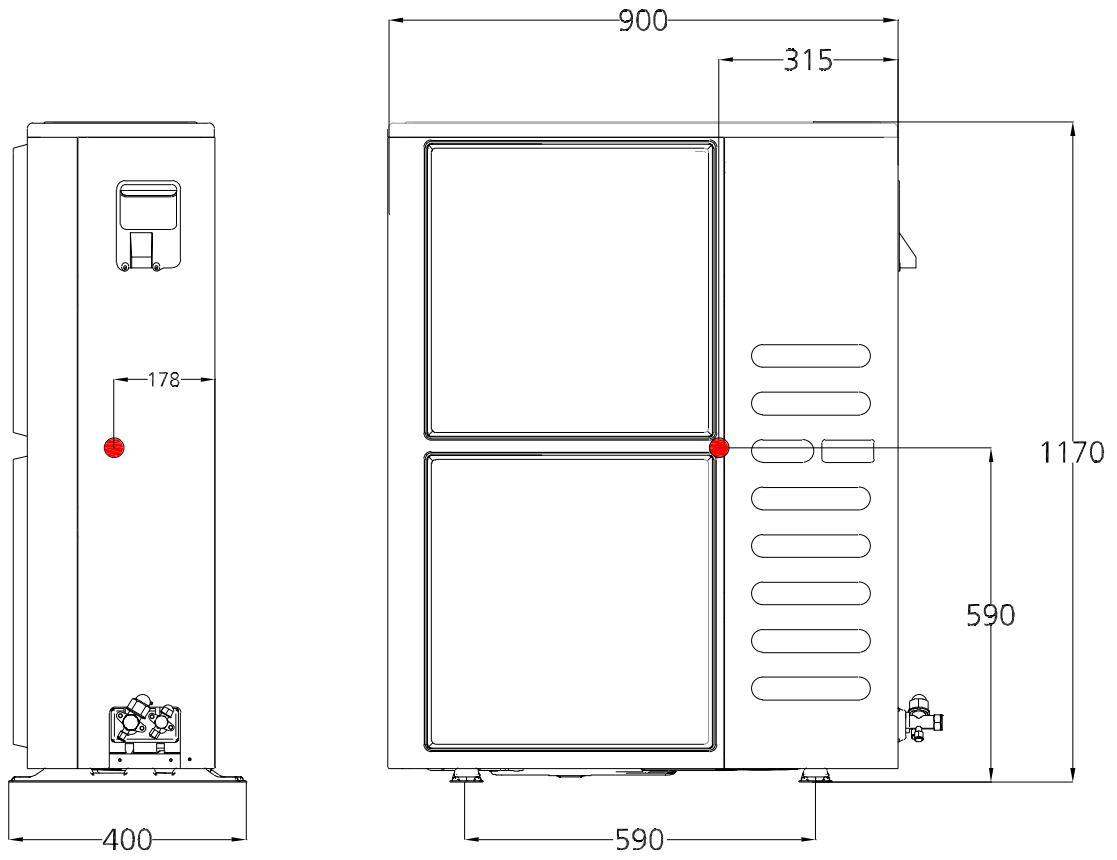

5. Electrical Wiring Diagrams

5.1 Indoor unit

Abbreviation	Paraphrase
Y/G	Yellow-Green Conductor
CAP1	Indoor Fan Capacitor
FAN	Indoor Fan
PUMP	PUMP
L	LIVE
N	NEUTRAL
TO CCM Comm.Bus	Central Controller
T1	Indoor Room Temperature
T2	Coil Temperature of Indoor Heat Exchanger
P1	Super High Speed
P2	High Speed

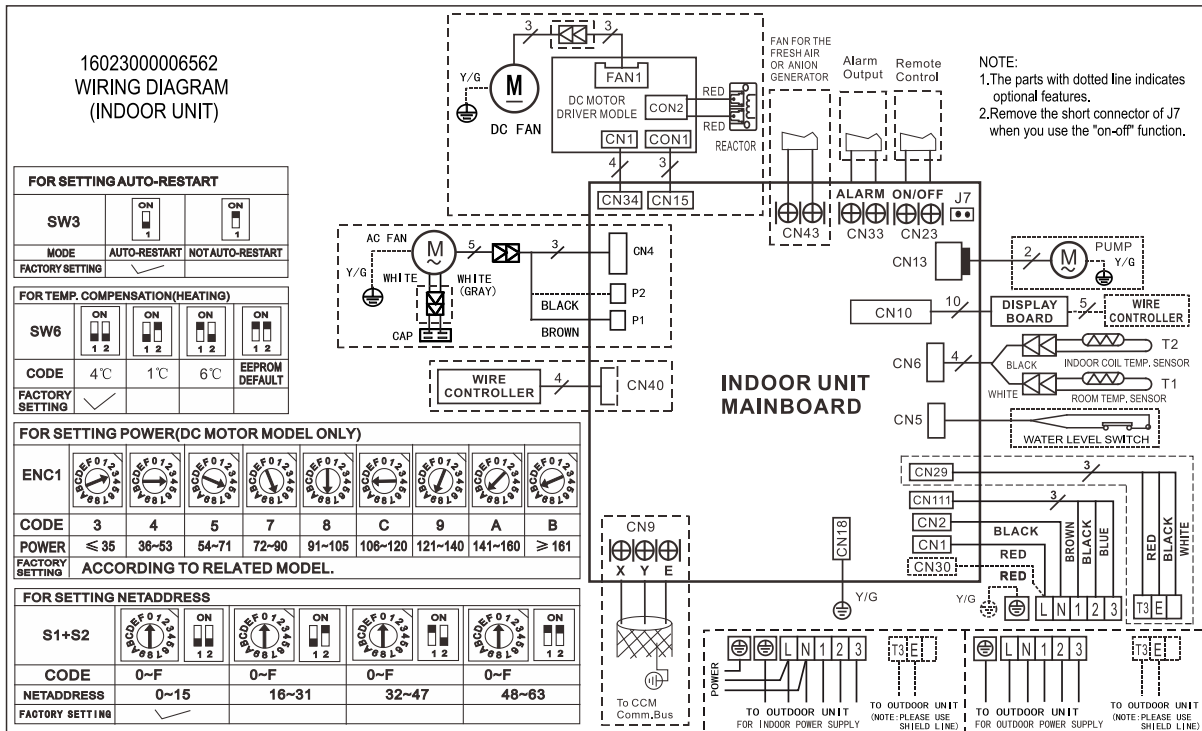

Air Condition Link-Circuit

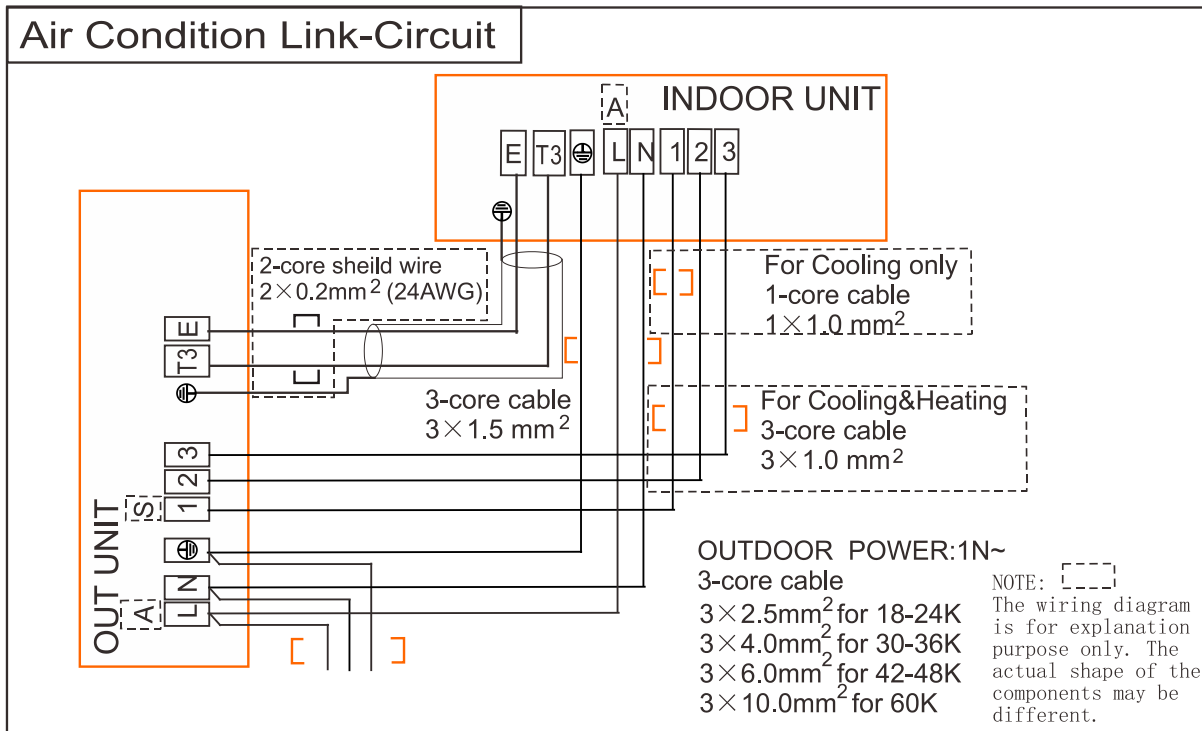

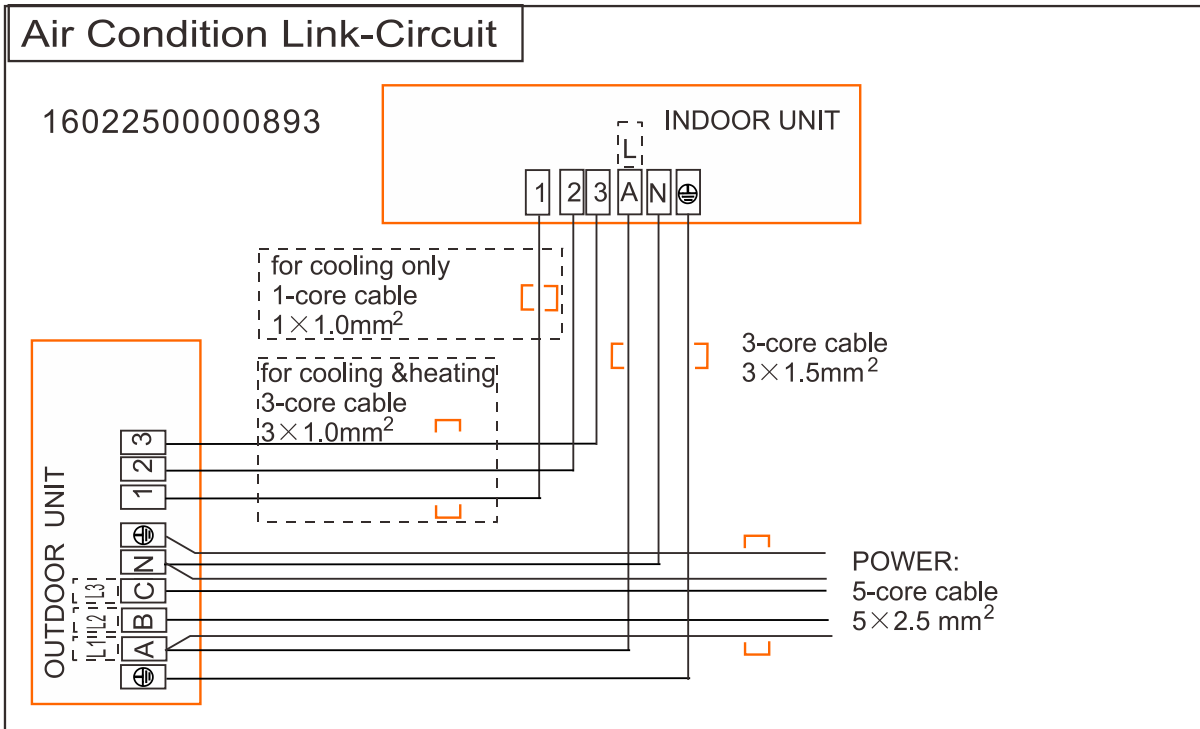
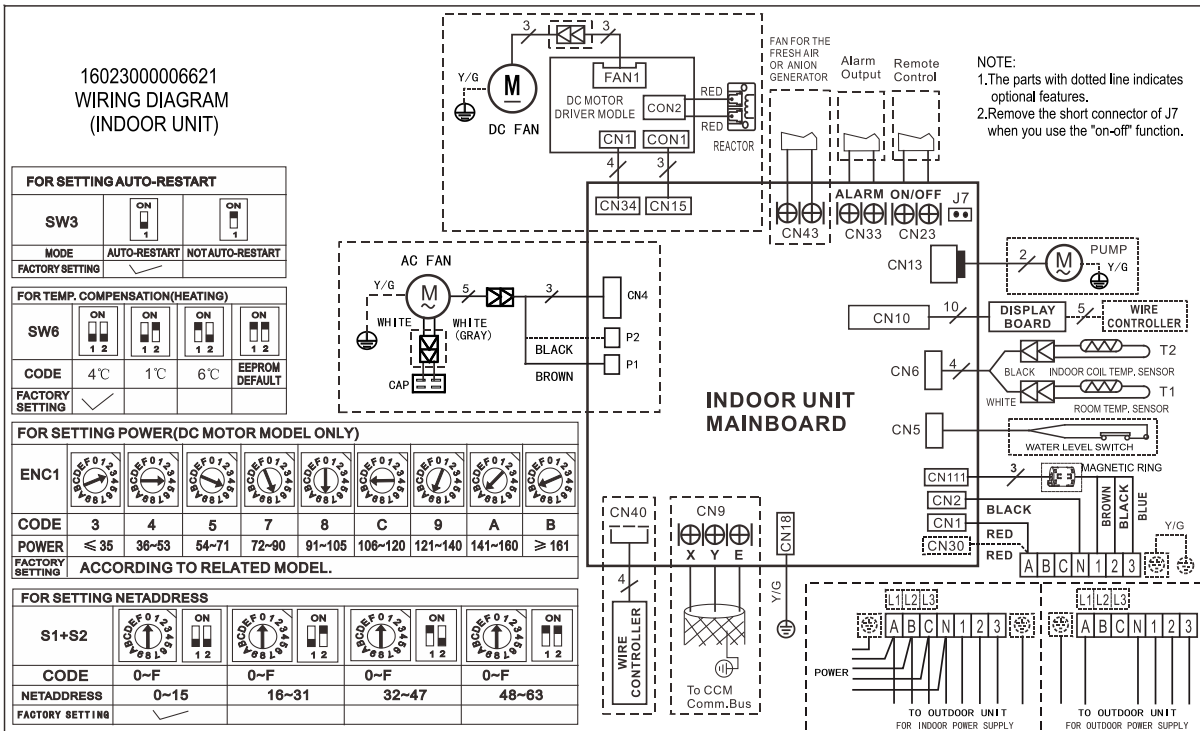

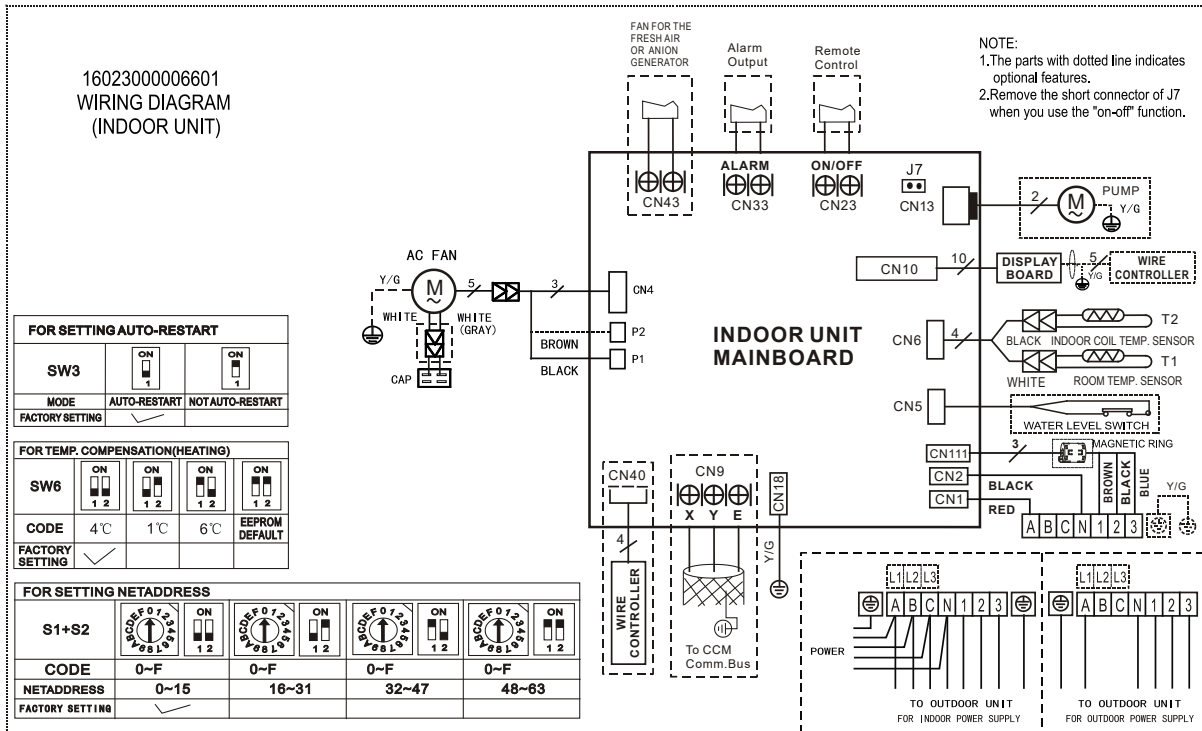

Air Condition Link-Circuit

16022500000890

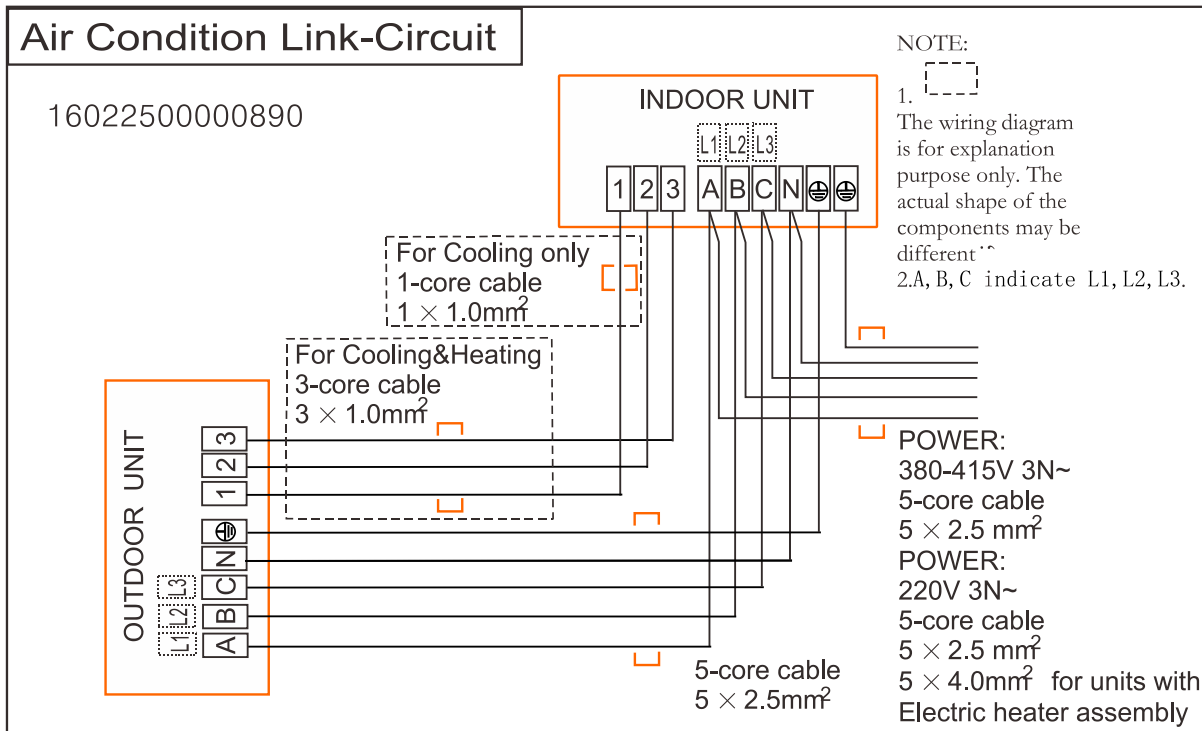

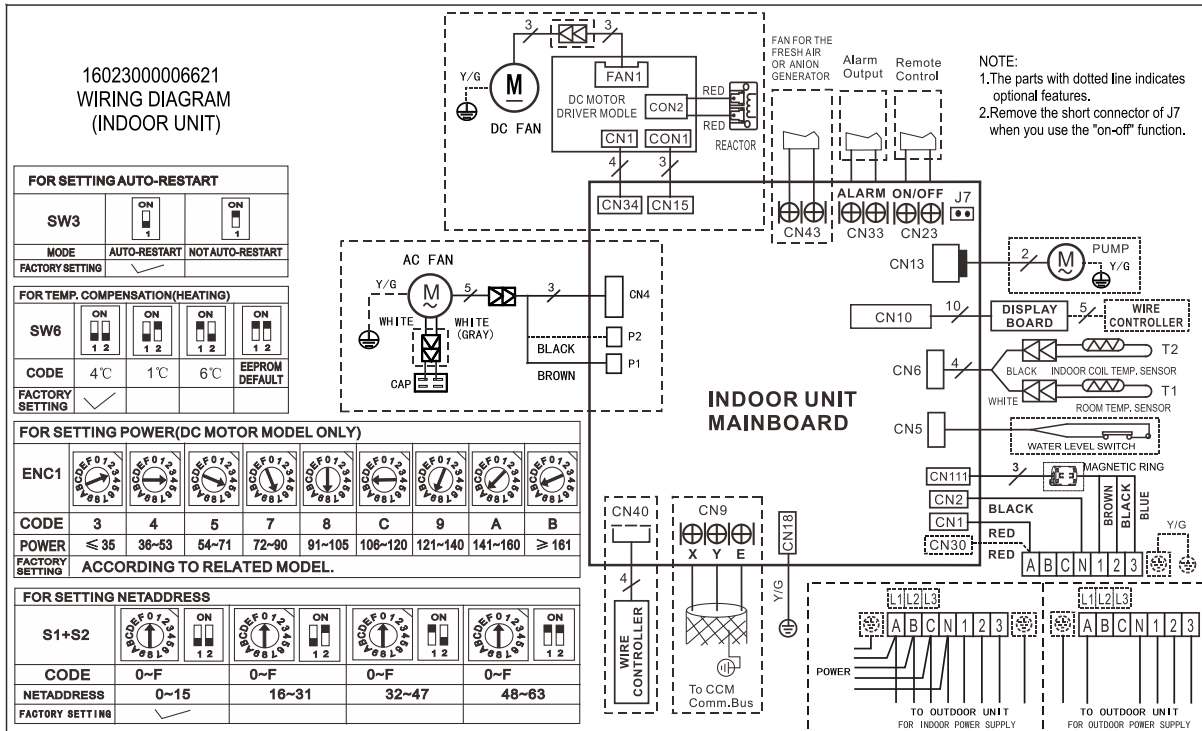

Air Condition Link-Circuit

16022500000890

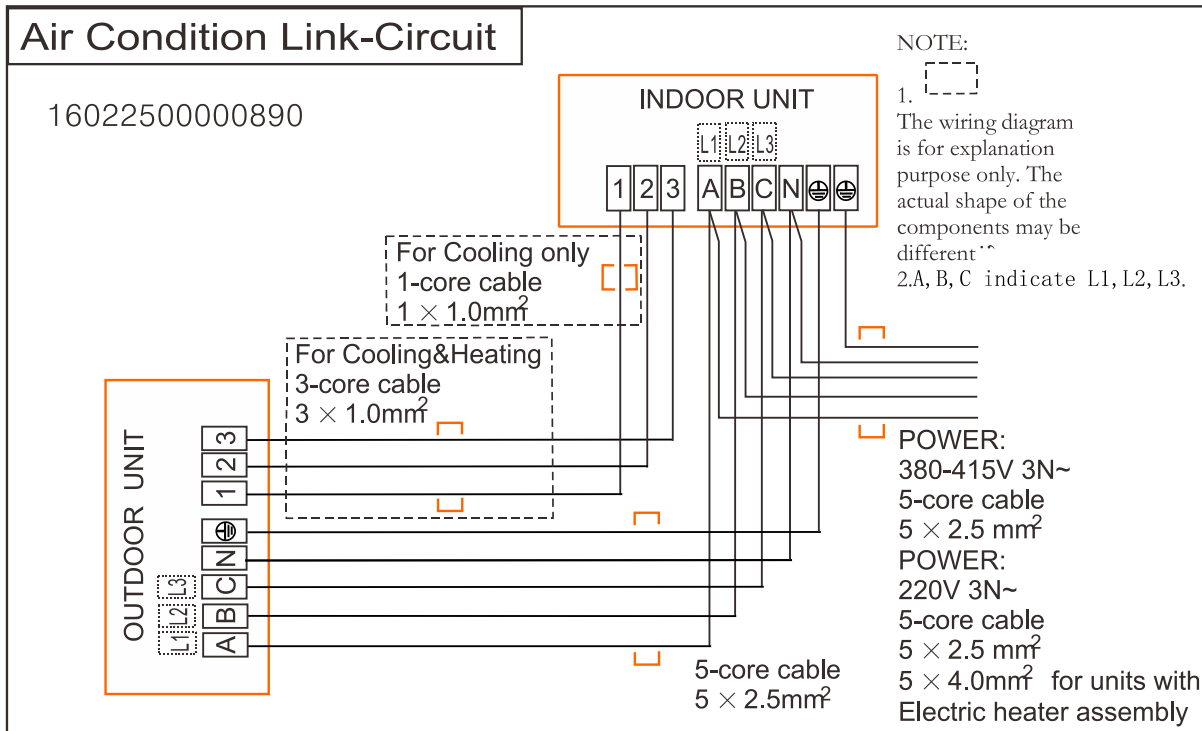

5.2 Some connectors introduce:

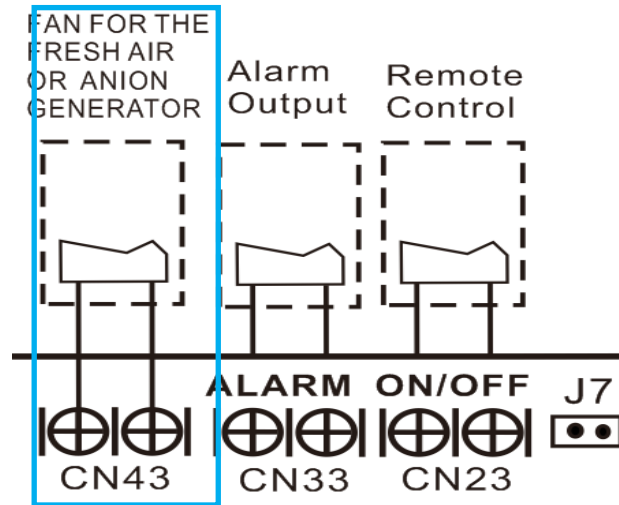

A. For new fresh motor terminal port (also for Anion generator) CN43:

1. Connect the fan motor to the port , no need care L/N of the motor ;
2. The output voltage is the power supply;
3. The fresh motor can not exceed 200W or 1A , follow the smaller one ;
4. The new fresh motor will be worked when the indoor fan motor work ;when the indoor fan motor stops , the new fresh motor would be stopped ;
5. When the unit enter force cooling mode or capacity testing mode , the fresh motor isn't work .

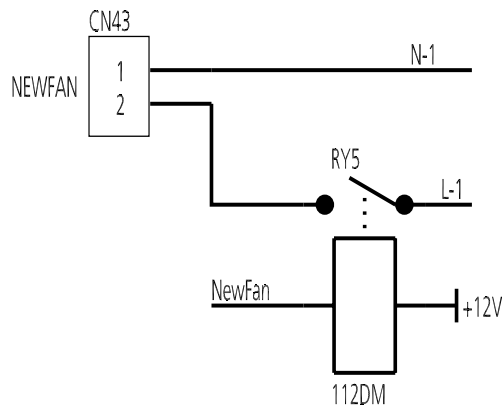

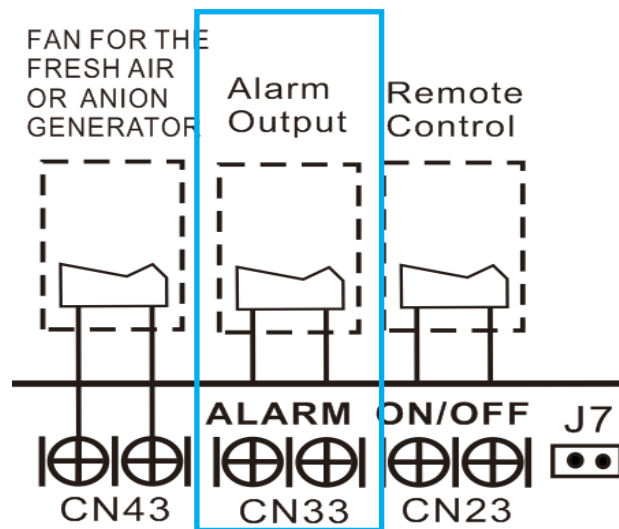

B For ALARM terminal port CN33

1. Provide the terminal port to connect ALARM ,but no voltage of the terminal port , the power from the ALARM system (not from the unit)
2. Although design voltage can support higher voltage ,but we strongly ask you connect the power less than 24V, current less than 0.5A
3. When the unit occurs the problem , the relay would be closed , then ALARM works

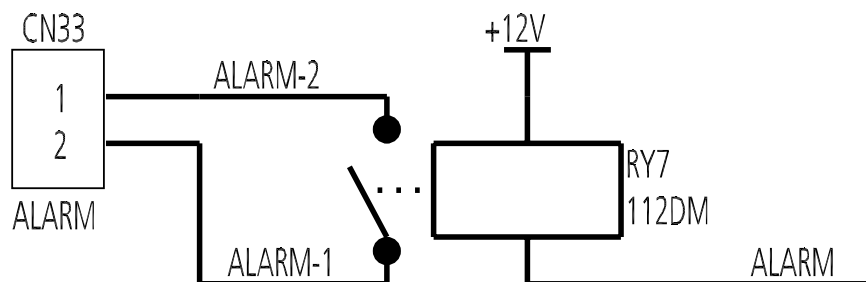

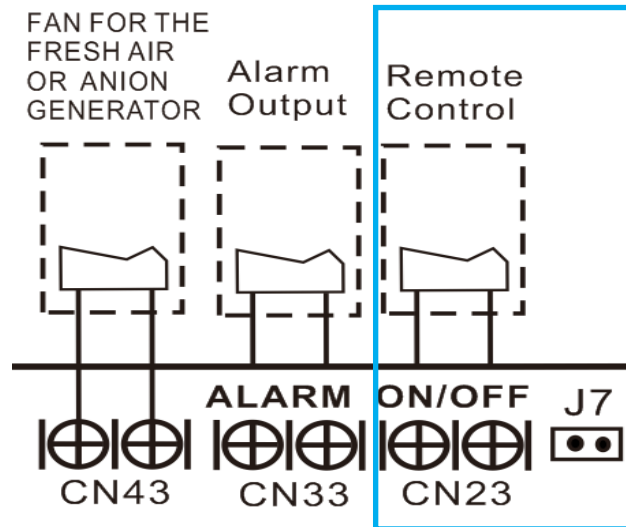

C. For remote control (ON-OFF) terminal port CN23 and short connector of J7

1. Remove the short connector of J7 when you use ON-OFF function;
2. When remote switch off (OPEN) ;the unit would be off;
3. When remote switch on (CLOSE) ;the unit would be on;
4. When close/open the remote switch, the unit would be responded the demand within 2 seconds;
5. When the remote switch on . you can use remote controller/ wire controller to select the mode what you want ;when the remote switch off , the unit would not respond the demand from remote controller/wire controller.

when the remote switch off , but the remote controller / wire controller are on, CP code would be shown on the display board.

6.The voltage of the port is 12V DC , design Max.current is 5mA.

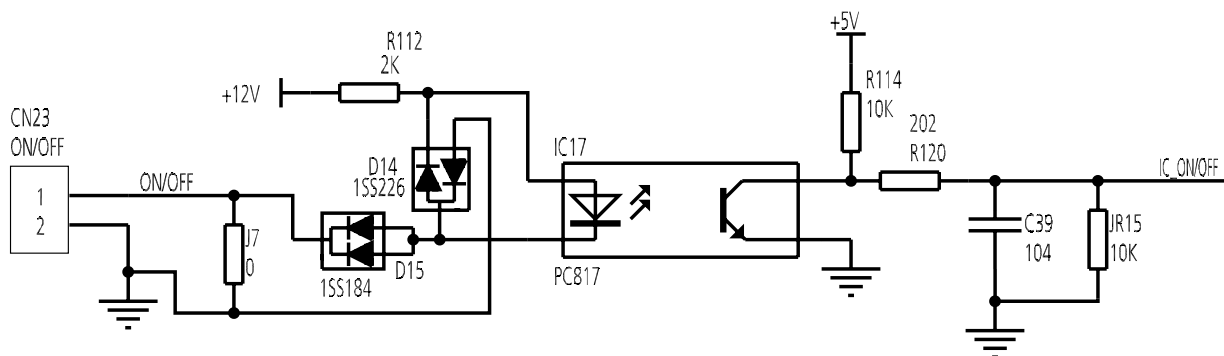

5.3 Outdoor Unit

Abbreviation	Paraphrase
CAP1, CAP2, CAP3,CAP4	Capacitor
FAN1	Outdoor Fan Motor
KM8	Contactora
CT1, CT2	AC Current Detector
COMP	Compressor
L-PRO, K2	Low Pressure Switch/Shorting Stub
K1	High Pressure Switch/Shorting Stub
TRANS	Power Transformer
T4	10KΩ RESISTANCE/Outdoor Ambient Temperature
T3	10KΩ RESISTANCE/Coil Temperature of Condenser
XT1	2-Way Terminal/4-Way Terminal
XT2	3-Way Terminal
XT4	Terminal
K3	Compressor Discharge Temperature/Shorting Stub
XP1~XP5,XT5~XT7	Connectors

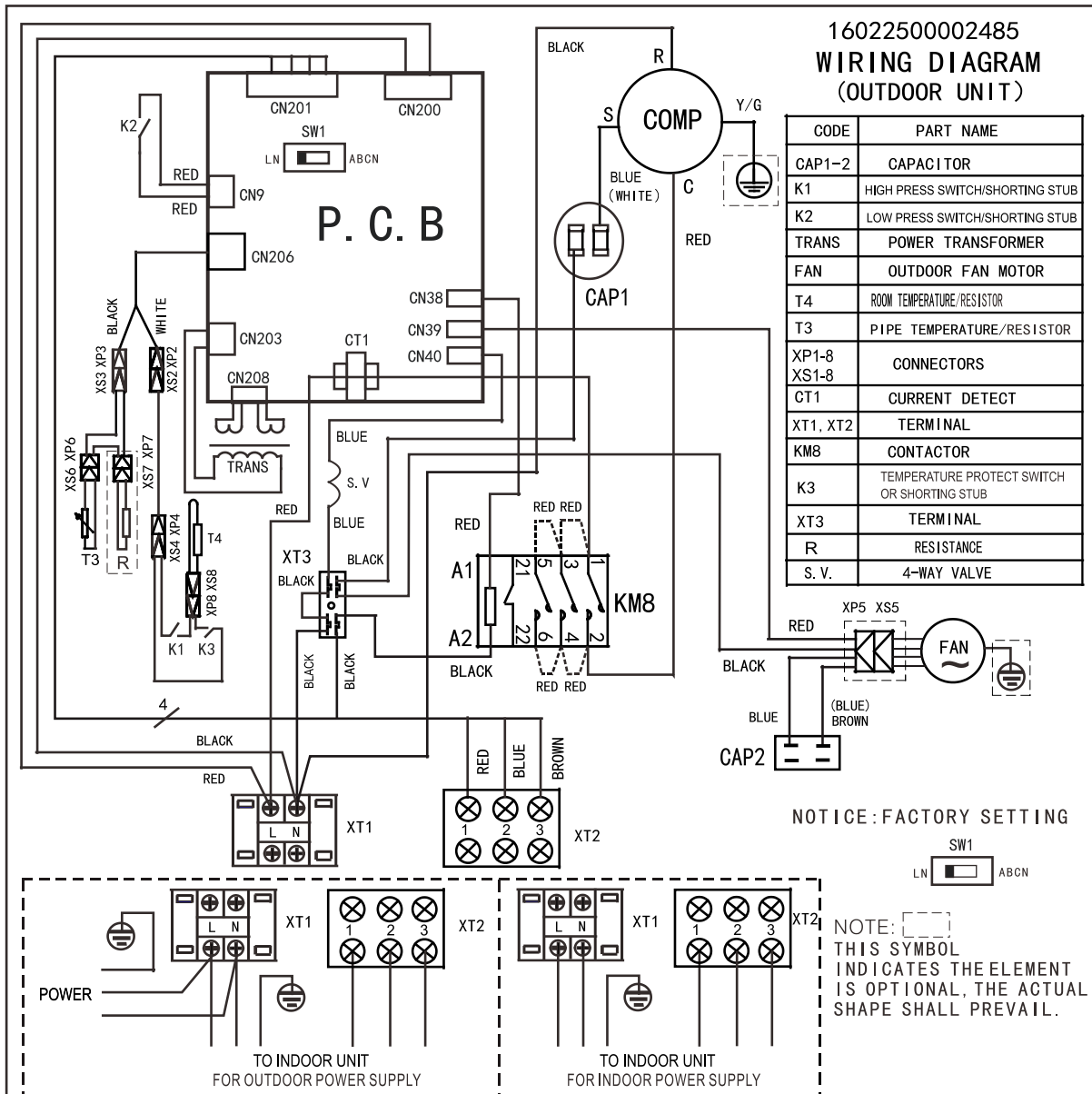

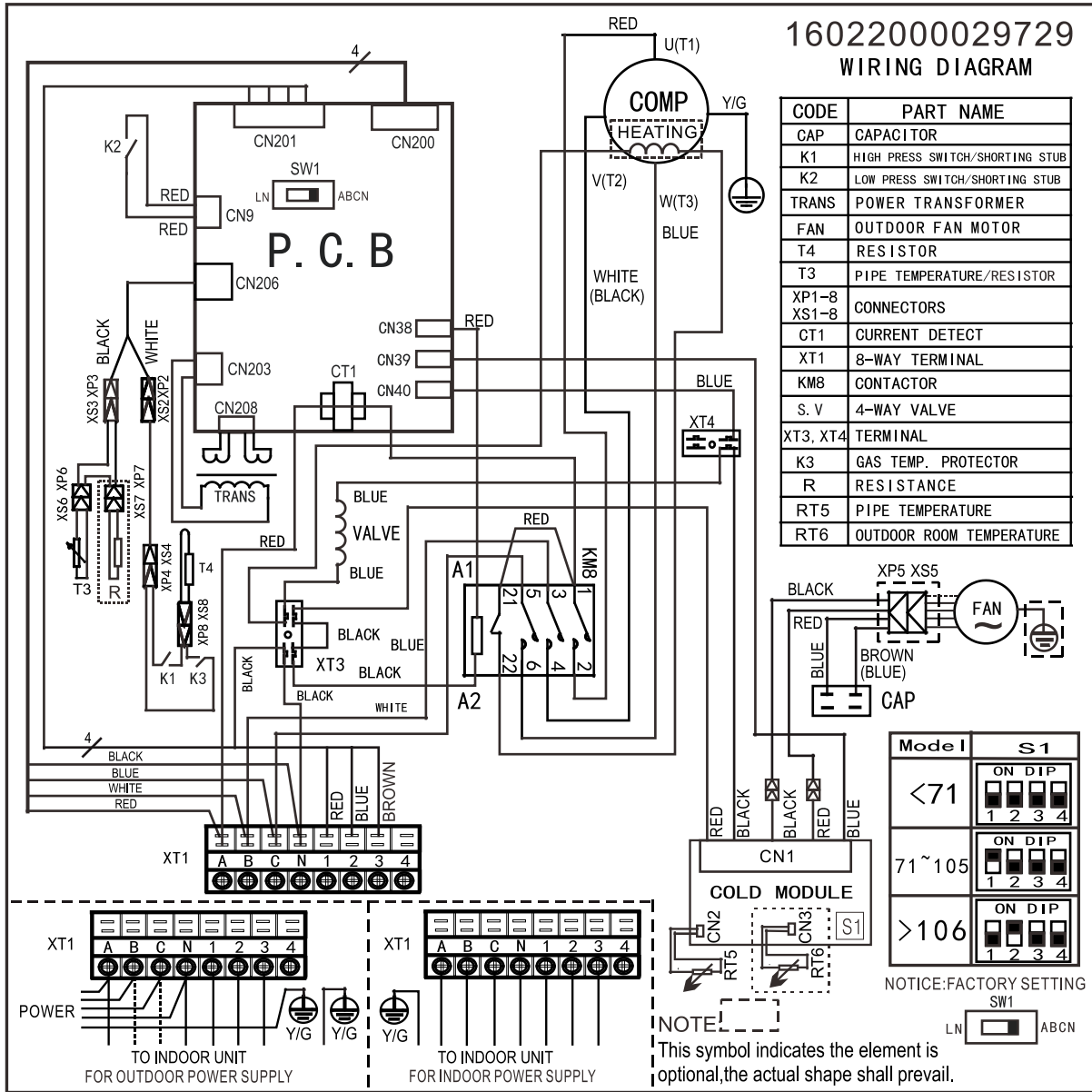

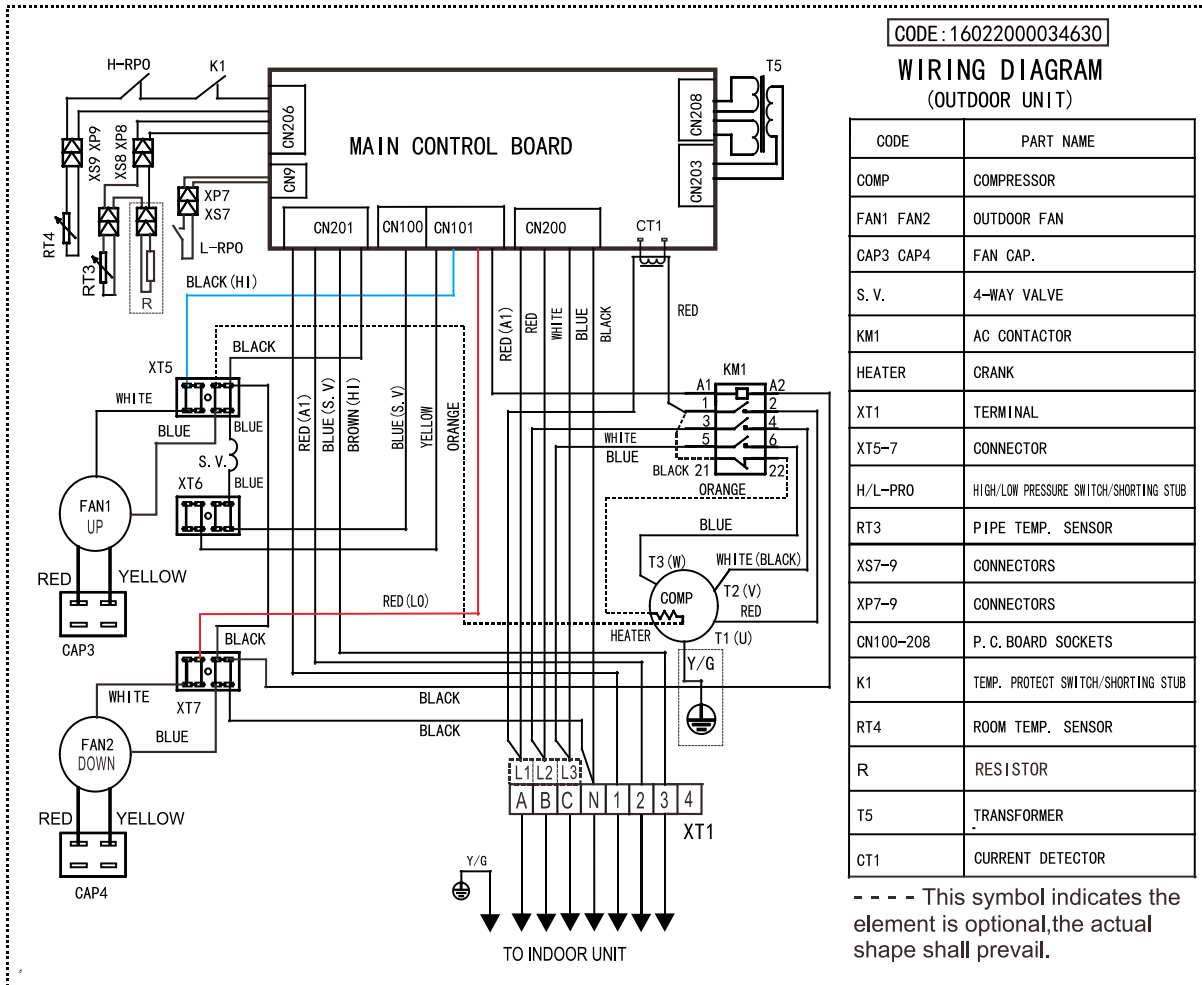

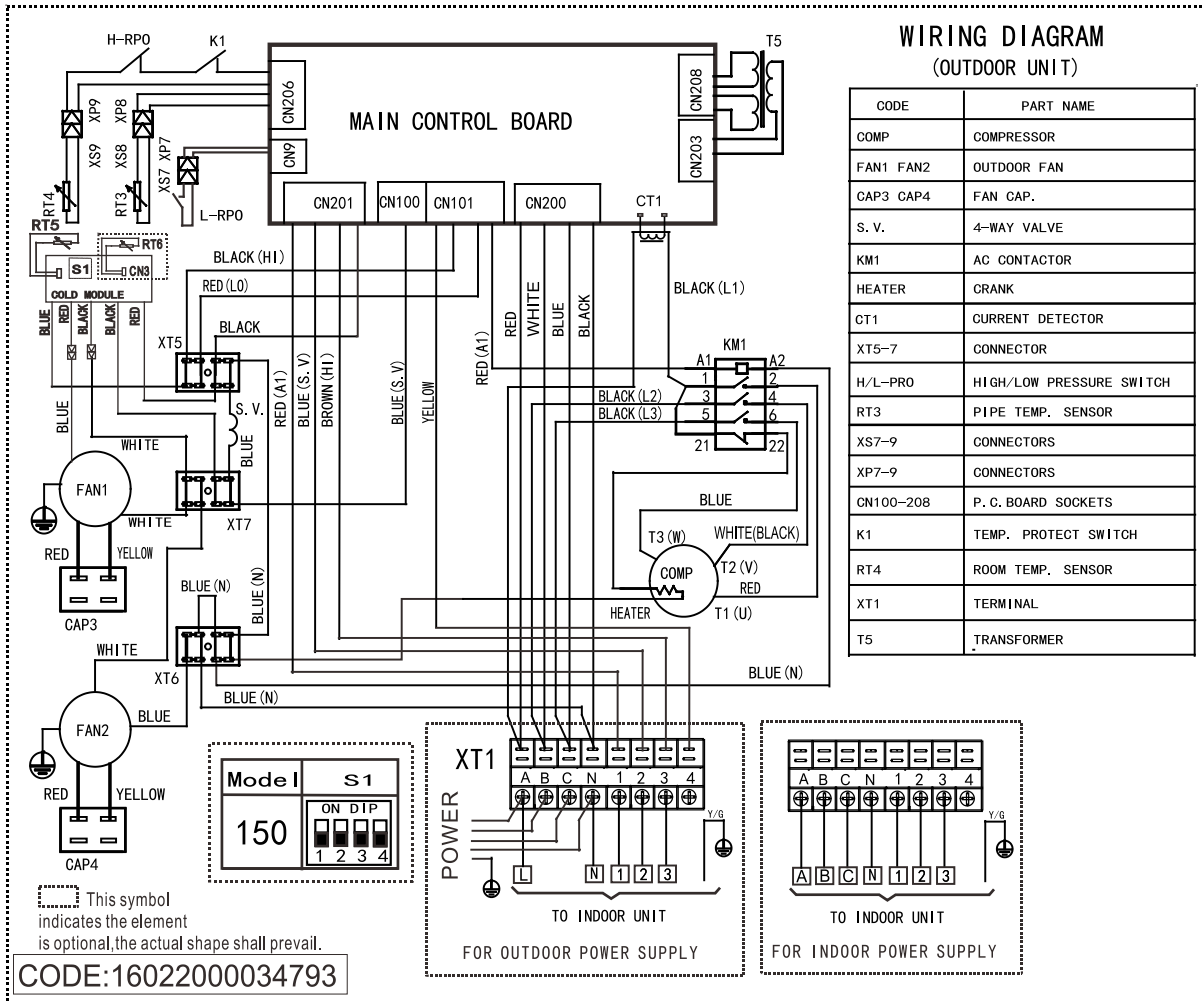

6. Refrigerant Cycle Diagrams

6.1 Heat pump

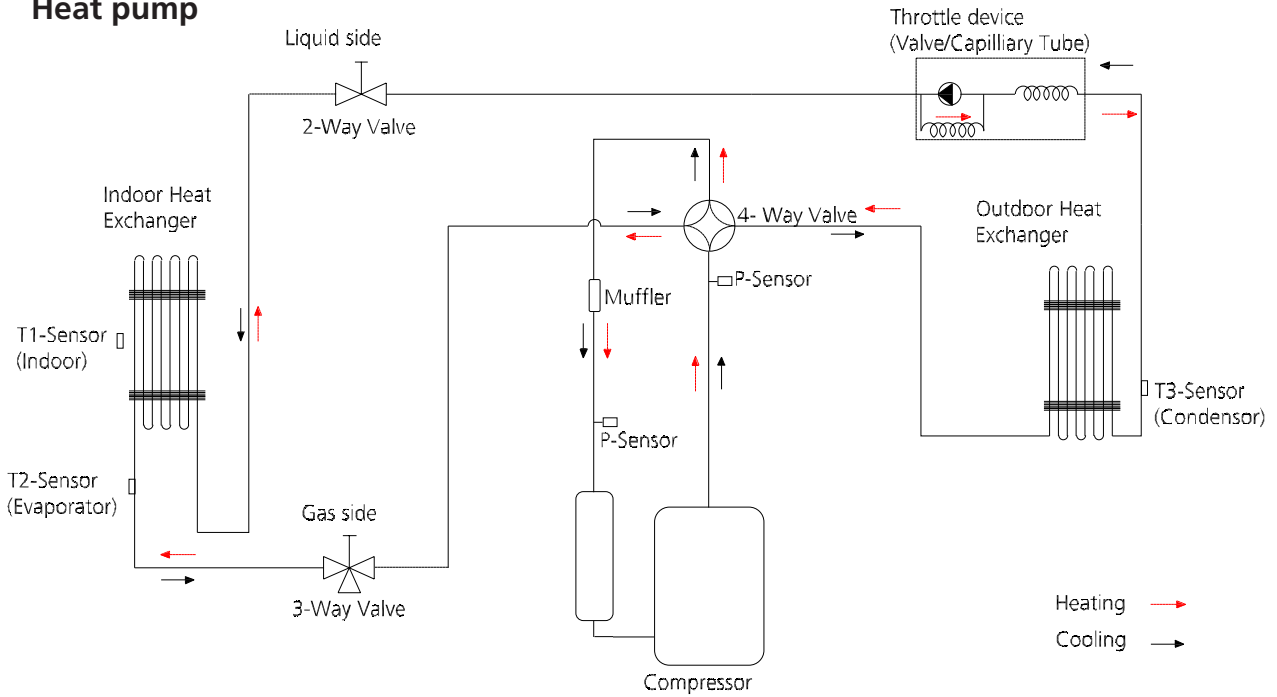

Model No.	Pipe Size(Diameter:ø) mm(inch)		Piping length(m/ft)		Elevation(m/ft)		Additional Refrigerant
	Gas	Liquid	Rated	Max.	Rated	Max.	
YFAD-100R-01M25	19(3/4)	9.52(3/8)	5/16.4	30/98.4	0	20/65.6	30g/m (0.32oz/ft)
YFAD-100R-01T35	19(3/4)	9.52(3/8)	5/16.4	30/98.4	0	20/65.6	30g/m (0.32oz/ft)

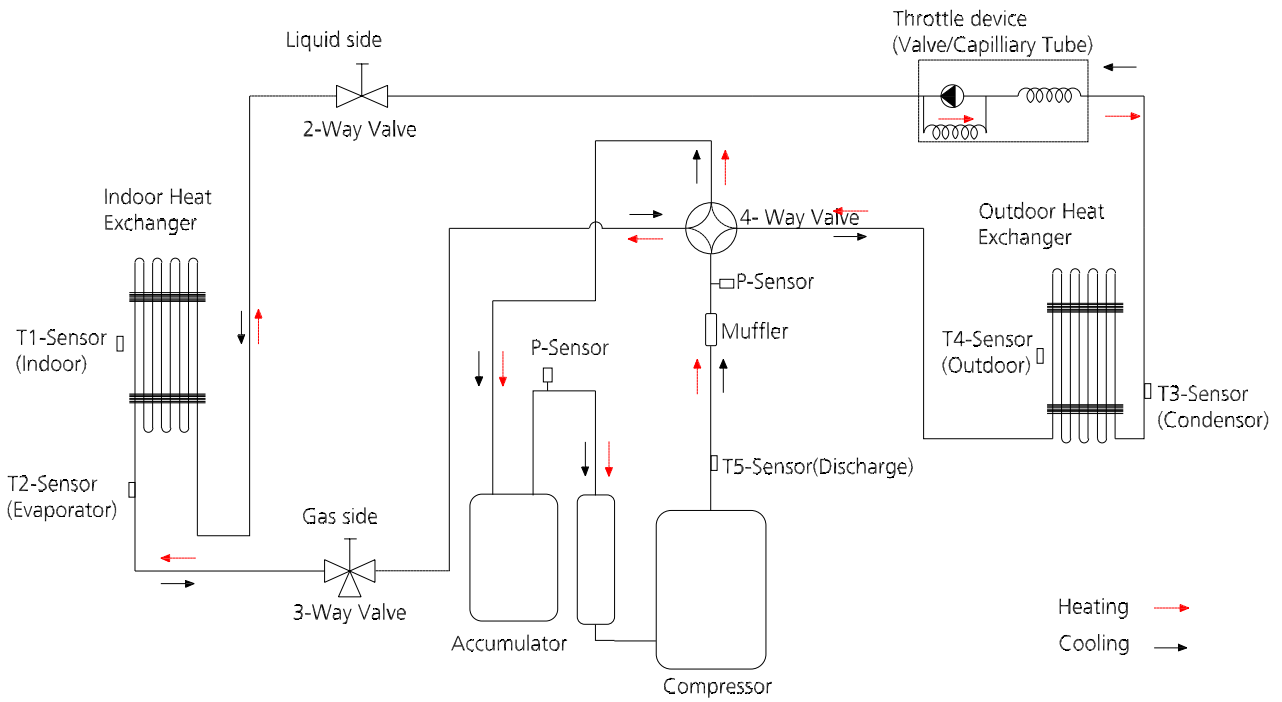

Model No.	Pipe Size (Diameter:ø) mm(inch)		Piping length(m/ft)		Elevation(m/ft)		Additional Refrigerant
	Gas	Liquid	Rated	Max.	Rated	Max.	
YFAD-140R-01T35	19(3/4)	9.52(3/8)	5/16.4	50/164	0	30/98.4	30g/m (0.32oz/ft)
YFAD-160R-01T35	19(3/4)	9.52(3/8)	5/16.4	50/164	0	30/98.4	30g/m (0.32oz/ft)

7. Capacity Tables

7.1 Cooling

DFMD-100N-01M25+YFAD-100R-01M25																			
INDOOR AIRFLOW (CMH)	OUT-DOOR DB (C)	ID WB (C)	16.0				18.0				19.0				22.0				
		ID DB (C)	23.0	25.0	27.0	29.0	23.0	25.0	27.0	29.0	23.0	25.0	27.0	29.0	23.0	25.0	27.0	29.0	
1160	15	TC	10.66	10.67	10.67	10.78	11.30	11.54	11.54	11.54	11.61	11.61	11.61	11.61	12.46	12.46	12.46	12.46	
		S/T	0.70	0.77	0.84	0.91	0.57	0.64	0.71	0.78	0.51	0.58	0.65	0.71	0.38	0.44	0.50	0.56	
		PI	2.72	2.72	2.72	2.72	2.71	2.71	2.71	2.71	2.71	2.71	2.71	2.71	2.70	2.70	2.70	2.70	
	20	TC	10.54	10.55	10.55	10.66	11.18	11.18	11.18	11.18	11.50	11.50	11.50	11.50	12.36	12.36	12.36	12.36	
		S/T	0.70	0.77	0.84	0.91	0.57	0.64	0.71	0.78	0.51	0.58	0.65	0.71	0.38	0.44	0.50	0.56	
		PI	2.82	2.81	2.81	2.82	2.80	2.80	2.80	2.80	2.80	2.80	2.80	2.80	2.78	2.78	2.78	2.78	
	25	TC	10.06	10.06	10.06	10.17	10.69	10.69	10.69	10.69	11.01	11.01	11.01	11.01	11.84	11.84	11.84	11.84	
		S/T	0.70	0.78	0.86	0.93	0.57	0.65	0.72	0.79	0.51	0.58	0.65	0.72	0.37	0.44	0.50	0.57	
		PI	3.10	3.10	3.10	3.10	3.10	3.10	3.10	3.10	3.10	3.10	3.10	3.10	3.10	3.10	3.10	3.10	
	30	TC	9.57	9.57	9.57	9.66	10.20	10.20	10.20	10.20	10.49	10.49	10.49	10.49	11.32	11.32	11.32	11.32	
		S/T	0.71	0.79	0.87	0.95	0.58	0.65	0.73	0.80	0.51	0.59	0.66	0.73	0.37	0.44	0.51	0.57	
		PI	3.40	3.40	3.40	3.40	3.41	3.41	3.41	3.41	3.41	3.41	3.41	3.41	3.42	3.42	3.42	3.42	
	35	TC	9.11	9.11	9.20	9.28	9.68	9.68	9.68	9.68	10.00	10.00	10.14	10.00	10.78	10.78	10.78	10.78	
		S/T	0.72	0.80	0.89	0.97	0.58	0.66	0.74	0.82	0.51	0.59	0.67	0.75	0.36	0.44	0.51	0.58	
		PI	3.71	3.71	3.71	3.71	3.73	3.73	3.73	3.73	3.73	3.73	3.74	3.73	3.76	3.76	3.76	3.76	
	40	TC	8.37	8.37	8.46	8.55	8.93	8.93	8.93	8.93	9.21	9.21	9.27	9.21	9.95	9.95	9.95	9.95	
		S/T	0.74	0.83	0.92	1.00	0.59	0.67	0.76	0.85	0.52	0.60	0.69	0.77	0.36	0.44	0.52	0.59	
		PI	4.24	4.24	4.24	4.24	4.26	4.26	4.26	4.26	4.27	4.27	4.27	4.27	4.30	4.30	4.30	4.30	
	43	TC	7.93	7.93	8.02	8.10	8.48	8.48	8.48	8.48	8.74	8.74	8.74	8.74	9.46	9.46	9.46	9.46	
		S/T	0.75	0.84	0.94	1.00	0.59	0.68	0.77	0.87	0.52	0.61	0.70	0.79	0.35	0.44	0.52	0.60	
		PI	4.56	4.56	4.56	4.56	4.58	4.58	4.58	4.58	4.59	4.59	4.59	4.59	4.63	4.63	4.63	4.63	
	1383	15	TC	10.87	10.87	10.99	11.11	11.54	11.54	11.54	11.54	11.85	11.85	11.85	11.85	12.73	12.73	12.73	12.73
			S/T	0.72	0.81	0.89	0.97	0.58	0.66	0.74	0.82	0.51	0.59	0.67	0.75	0.36	0.44	0.51	0.58
			PI	2.78	2.78	2.78	2.78	2.77	2.77	2.77	2.77	2.77	2.77	2.77	2.77	2.76	2.76	2.76	2.76
20		TC	10.75	10.75	10.87	10.98	11.41	11.41	11.41	11.41	11.73	11.73	11.73	11.73	12.62	12.62	12.62	12.62	
		S/T	0.72	0.81	0.89	0.97	0.58	0.66	0.74	0.82	0.51	0.59	0.67	0.75	0.36	0.44	0.51	0.58	
		PI	2.88	2.88	2.88	2.88	2.86	2.86	2.86	2.86	2.86	2.86	2.86	2.86	2.84	2.84	2.84	2.84	
25		TC	10.26	10.26	10.38	10.49	10.90	10.90	10.90	10.90	11.21	11.21	11.21	11.21	12.07	12.07	12.07	12.07	
		S/T	0.73	0.82	0.91	0.99	0.58	0.67	0.75	0.84	0.52	0.60	0.68	0.76	0.36	0.44	0.51	0.59	
		PI	3.17	3.17	3.17	3.17	3.17	3.17	3.17	3.17	3.17	3.17	3.17	3.17	3.17	3.17	3.17	3.17	
30		TC	9.77	9.77	9.86	9.95	10.41	10.41	10.41	10.41	10.72	10.72	10.72	10.72	11.53	11.53	11.53	11.53	
		S/T	0.74	0.83	0.93	1.00	0.59	0.68	0.77	0.86	0.52	0.60	0.69	0.78	0.36	0.44	0.52	0.60	
		PI	3.47	3.47	3.47	3.47	3.48	3.48	3.48	3.48	3.48	3.48	3.48	3.48	3.50	3.50	3.50	3.50	
35		TC	9.29	9.29	9.37	9.46	9.89	9.89	9.89	9.89	10.18	10.18	10.35	10.18	10.98	10.98	10.98	10.98	
		S/T	0.75	0.85	0.95	1.00	0.59	0.69	0.78	0.87	0.52	0.61	0.70	0.79	0.35	0.44	0.52	0.61	
		PI	3.79	3.79	3.79	3.79	3.81	3.81	3.81	3.81	3.81	3.81	3.82	3.81	3.81	3.81	3.81	3.81	
40		TC	8.47	8.52	8.61	8.69	9.03	9.03	9.03	9.09	9.30	9.30	9.36	9.30	10.06	10.06	10.06	10.06	
		S/T	0.77	0.88	0.99	1.00	0.60	0.71	0.81	0.91	0.53	0.63	0.73	0.83	0.35	0.44	0.53	0.62	
		PI	4.33	4.33	4.33	4.33	4.35	4.35	4.35	4.35	4.36	4.36	4.37	4.36	4.39	4.39	4.39	4.39	
43		TC	8.03	8.12	8.20	8.29	8.57	8.57	8.57	8.66	8.83	8.83	8.83	8.83	9.57	9.57	9.57	9.57	
		S/T	0.79	0.90	1.00	1.00	0.61	0.72	0.82	0.93	0.53	0.63	0.74	0.84	0.34	0.44	0.54	0.63	
		PI	4.65	4.65	4.65	4.65	4.67	4.67	4.67	4.67	4.69	4.69	4.69	4.69	4.73	4.73	4.73	4.73	

INDOOR AIRFLOW (CMH)	OUT-DOOR DB(C)	ID WB (C)	16.0				18.0				19.0				22.0			
		ID DB (C)	23.0	25.0	27.0	29.0	23.0	25.0	27.0	29.0	23.0	25.0	27.0	29.0	23.0	25.0	27.0	29.0
1836	15	TC	11.08	11.19	11.31	11.43	11.74	11.74	11.74	11.86	12.08	12.08	12.08	12.08	12.96	12.96	12.96	12.96
		S/T	0.78	0.89	1.00	1.00	0.61	0.71	0.82	0.92	0.53	0.63	0.73	0.84	0.34	0.44	0.54	0.63
		PI	2.84	2.84	2.84	2.84	2.82	2.82	2.82	2.82	2.83	2.83	2.83	2.83	2.82	2.82	2.82	2.82
	20	TC	10.95	11.07	11.18	11.30	11.61	11.61	11.61	11.73	11.96	11.96	11.96	11.96	12.85	12.85	12.85	12.85
		S/T	0.78	0.89	1.00	1.00	0.61	0.71	0.82	0.92	0.53	0.63	0.73	0.84	0.34	0.44	0.54	0.63
		PI	2.94	2.94	2.94	2.94	2.92	2.92	2.92	2.92	2.92	2.92	2.92	2.92	2.90	2.90	2.90	2.90
	25	TC	10.46	10.58	10.69	10.81	11.10	11.10	11.10	11.21	11.44	11.44	11.44	11.44	12.30	12.30	12.30	12.30
		S/T	0.79	0.91	1.00	1.00	0.62	0.73	0.84	0.94	0.53	0.64	0.75	0.86	0.34	0.44	0.54	0.64
		PI	3.23	3.23	3.23	3.23	3.23	3.23	3.23	3.23	3.23	3.23	3.23	3.23	3.23	3.23	3.23	3.23
	30	TC	9.98	10.06	10.18	10.29	10.61	10.61	10.61	10.72	10.92	10.92	10.92	10.92	11.76	11.76	11.76	11.76
		S/T	0.81	0.93	1.00	1.00	0.62	0.74	0.85	0.97	0.54	0.65	0.76	0.87	0.34	0.44	0.55	0.65
		PI	3.54	3.54	3.54	3.54	3.55	3.55	3.55	3.55	3.56	3.56	3.56	3.56	3.57	3.57	3.57	3.57
	35	TC	9.46	9.54	9.63	9.72	10.06	10.06	10.06	10.18	10.38	10.38	10.55	10.67	11.21	11.21	11.21	11.21
		S/T	0.83	0.95	1.00	1.00	0.63	0.75	0.88	0.99	0.54	0.66	0.77	0.89	0.34	0.45	0.56	0.67
		PI	3.87	3.87	3.87	3.87	3.89	3.89	3.89	3.89	3.89	3.89	3.90	3.89	3.92	3.92	3.92	3.92
	40	TC	8.62	8.71	8.79	8.88	9.19	9.19	9.24	9.33	9.48	9.48	9.54	9.64	10.27	10.27	10.27	10.27
		S/T	0.86	1.00	1.00	1.00	0.65	0.78	0.91	1.00	0.55	0.68	0.81	0.94	0.33	0.45	0.57	0.90
		PI	4.42	4.42	4.42	4.42	4.44	4.44	4.44	4.44	4.45	4.45	4.46	4.45	4.49	4.49	4.49	4.49
	43	TC	8.17	8.26	8.35	8.43	8.72	8.72	8.80	8.89	9.00	9.00	9.00	9.09	9.77	9.77	9.77	9.77
		S/T	0.88	1.00	1.00	1.00	0.66	0.80	0.93	1.00	0.56	0.69	0.83	0.96	0.33	0.45	0.58	0.92
		PI	4.75	4.75	4.75	4.75	4.77	4.77	4.77	4.77	4.79	4.79	4.79	4.79	4.83	4.83	4.83	4.83

TC:Total Cooling Capacity (kW)
S/T:Sensible Cooling Capacity Ratio
PI:Power Input(kW)

DFMD-100N-01M25+YFAD-100R-01M25																		
INDOOR AIRFLOW (CMH)	OUT-DOOR DB(C)	ID WB (C)	16.0				18.0				19.0				22.0			
			ID DB (C)	23.0	25.0	27.0	29.0	23.0	25.0	27.0	29.0	23.0	25.0	27.0	29.0	23.0	25.0	27.0
950	15	TC	10.66	10.67	10.67	10.67	11.30	11.54	11.54	11.54	11.61	11.61	11.61	11.61	12.46	12.46	12.46	12.46
		S/T	0.68	0.74	0.80	0.86	0.57	0.62	0.68	0.74	0.52	0.57	0.63	0.68	0.40	0.45	0.50	0.55
		PI	2.72	2.72	2.72	2.72	2.71	2.71	2.71	2.71	2.71	2.71	2.71	2.71	2.70	2.70	2.70	2.70
	20	TC	10.54	10.55	10.55	10.55	11.18	11.18	11.18	11.18	11.50	11.50	11.50	11.50	12.36	12.36	12.36	12.36
		S/T	0.68	0.74	0.80	0.86	0.57	0.63	0.68	0.74	0.52	0.57	0.63	0.68	0.40	0.45	0.50	0.55
		PI	2.82	2.81	2.81	2.82	2.80	2.80	2.80	2.80	2.80	2.80	2.80	2.80	2.78	2.78	2.78	2.78
	25	TC	10.06	10.06	10.06	10.06	10.69	10.69	10.69	10.69	11.01	11.01	11.01	11.01	11.84	11.84	11.84	11.84
		S/T	0.68	0.74	0.81	0.87	0.57	0.63	0.69	0.75	0.52	0.57	0.63	0.69	0.39	0.45	0.50	0.55
		PI	3.10	3.10	3.10	3.10	3.10	3.10	3.10	3.10	3.10	3.10	3.10	3.10	3.10	3.10	3.10	3.10
	30	TC	9.57	9.57	9.57	9.57	10.20	10.20	10.20	10.20	10.49	10.49	10.49	10.49	11.32	11.32	11.32	11.32
		S/T	0.69	0.75	0.82	0.88	0.57	0.63	0.69	0.76	0.51	0.57	0.63	0.70	0.39	0.44	0.50	0.56
		PI	3.40	3.40	3.40	3.40	3.41	3.41	3.41	3.41	3.41	3.41	3.41	3.41	3.42	3.42	3.42	3.42
	35	TC	9.11	9.11	9.11	9.20	9.68	9.68	9.68	9.68	10.00	10.00	10.14	10.00	10.78	10.78	10.78	10.78
		S/T	0.69	0.76	0.83	0.90	0.57	0.63	0.70	0.77	0.51	0.58	0.64	0.70	0.38	0.44	0.50	0.56
		PI	3.71	3.71	3.71	3.71	3.73	3.73	3.73	3.73	3.73	3.73	3.74	3.73	3.76	3.76	3.76	3.76
	40	TC	8.37	8.37	8.37	8.46	8.93	8.93	8.93	8.93	9.21	9.21	9.27	9.21	9.95	9.95	9.95	9.95
		S/T	0.70	0.78	0.86	0.93	0.57	0.64	0.72	0.79	0.51	0.58	0.65	0.72	0.37	0.44	0.50	0.57
		PI	4.24	4.24	4.24	4.24	4.26	4.26	4.26	4.26	4.27	4.27	4.27	4.27	4.30	4.30	4.30	4.30
43	TC	7.93	7.93	7.93	8.02	8.48	8.48	8.48	8.48	8.74	8.74	8.74	8.74	9.46	9.46	9.46	9.46	
	S/T	0.71	0.79	0.87	0.94	0.57	0.65	0.72	0.80	0.51	0.59	0.66	0.73	0.37	0.44	0.50	0.57	
	PI	4.56	4.56	4.56	4.56	4.58	4.58	4.58	4.58	4.59	4.59	4.59	4.59	4.63	4.63	4.63	4.63	
1280	15	TC	10.87	10.87	10.87	10.99	11.54	11.54	11.54	11.54	11.85	11.85	11.85	11.85	12.73	12.73	12.73	12.73
		S/T	0.71	0.79	0.87	0.94	0.57	0.65	0.72	0.80	0.51	0.59	0.66	0.73	0.37	0.44	0.50	0.57
		PI	2.78	2.78	2.78	2.78	2.77	2.77	2.77	2.77	2.77	2.77	2.77	2.77	2.76	2.76	2.76	2.76
	20	TC	10.75	10.75	10.75	10.87	11.41	11.41	11.41	11.41	11.73	11.73	11.73	11.73	12.62	12.62	12.62	12.62
		S/T	0.71	0.79	0.87	0.94	0.57	0.65	0.72	0.80	0.51	0.59	0.66	0.73	0.37	0.44	0.50	0.57
		PI	2.88	2.88	2.88	2.88	2.86	2.86	2.86	2.86	2.86	2.86	2.86	2.86	2.84	2.84	2.84	2.84
	25	TC	10.26	10.26	10.26	10.38	10.90	10.90	10.90	10.90	11.21	11.21	11.21	11.21	12.07	12.07	12.07	12.07
		S/T	0.71	0.80	0.88	0.96	0.58	0.66	0.73	0.81	0.51	0.59	0.67	0.74	0.37	0.44	0.51	0.58
		PI	3.17	3.17	3.17	3.17	3.17	3.17	3.17	3.17	3.17	3.17	3.17	3.17	3.17	3.17	3.17	3.17
	30	TC	9.77	9.77	9.86	9.95	10.41	10.41	10.41	10.41	10.72	10.72	10.72	10.72	11.53	11.53	11.53	11.53
		S/T	0.72	0.81	0.90	0.98	0.58	0.66	0.75	0.83	0.51	0.59	0.67	0.75	0.36	0.44	0.51	0.58
		PI	3.47	3.47	3.47	3.47	3.48	3.48	3.48	3.48	3.48	3.48	3.48	3.48	3.50	3.50	3.50	3.50
	35	TC	9.29	9.29	9.37	9.46	9.89	9.89	9.89	9.89	10.18	10.18	10.35	10.18	10.98	10.98	10.98	10.98
		S/T	0.73	0.83	0.91	1.00	0.59	0.67	0.76	0.85	0.52	0.60	0.68	0.77	0.36	0.44	0.51	0.59
		PI	3.79	3.79	3.79	3.79	3.81	3.81	3.81	3.81	3.81	3.81	3.82	3.81	3.81	3.81	3.81	3.81
	40	TC	8.47	8.47	8.56	8.64	9.03	9.03	9.03	9.09	9.30	9.30	9.36	9.30	10.06	10.06	10.06	10.06
		S/T	0.75	0.86	0.95	1.00	0.59	0.69	0.79	0.88	0.52	0.61	0.71	0.80	0.35	0.44	0.52	0.61
		PI	4.33	4.33	4.33	4.33	4.35	4.35	4.35	4.35	4.36	4.36	4.37	4.36	4.39	4.39	4.39	4.39
43	TC	8.03	8.03	8.12	8.20	8.57	8.57	8.57	8.66	8.83	8.83	8.83	8.83	9.57	9.57	9.57	9.57	
	S/T	0.76	0.87	0.97	1.00	0.60	0.70	0.80	0.89	0.52	0.62	0.72	0.81	0.35	0.44	0.53	0.62	
	PI	4.65	4.65	4.65	4.65	4.67	4.67	4.67	4.67	4.69	4.69	4.69	4.69	4.73	4.73	4.73	4.73	

INDOOR AIRFLOW (CMH)	OUT-DOOR DB(C)	ID WB (C)	16.0				18.0				19.0				22.0			
		ID DB (C)	23.0	25.0	27.0	29.0	23.0	25.0	27.0	29.0	23.0	25.0	27.0	29.0	23.0	25.0	27.0	29.0
1700	15	TC	11.08	11.08	11.19	11.31	11.74	11.74	11.74	11.86	12.08	12.08	12.08	12.08	12.96	12.96	12.96	12.96
		S/T	0.76	0.86	0.96	1.00	0.60	0.70	0.79	0.89	0.52	0.62	0.71	0.81	0.35	0.44	0.53	0.62
		PI	2.84	2.84	2.84	2.84	2.82	2.82	2.82	2.82	2.83	2.83	2.83	2.83	2.82	2.82	2.82	2.82
	20	TC	10.95	10.95	11.07	11.18	11.61	11.61	11.61	11.73	11.96	11.96	11.96	11.96	12.85	12.85	12.85	12.85
		S/T	0.76	0.86	0.96	1.00	0.60	0.70	0.79	0.89	0.52	0.62	0.71	0.81	0.35	0.44	0.53	0.62
		PI	2.94	2.94	2.94	2.94	2.92	2.92	2.92	2.92	2.92	2.92	2.92	2.92	2.90	2.90	2.90	2.90
	25	TC	10.46	10.46	10.58	10.69	11.10	11.10	11.10	11.21	11.44	11.44	11.44	11.44	12.30	12.30	12.30	12.30
		S/T	0.77	0.88	0.98	1.00	0.60	0.71	0.81	0.91	0.53	0.63	0.73	0.83	0.35	0.44	0.53	0.62
		PI	3.23	3.23	3.23	3.23	3.23	3.23	3.23	3.23	3.23	3.23	3.23	3.23	3.23	3.23	3.23	3.23
	30	TC	9.98	10.06	10.18	10.29	10.61	10.61	10.61	10.72	10.92	10.92	10.92	10.92	11.76	11.76	11.76	11.76
		S/T	0.79	0.90	1.00	1.00	0.61	0.72	0.83	0.93	0.53	0.63	0.74	0.84	0.34	0.44	0.54	0.63
		PI	3.54	3.54	3.54	3.54	3.55	3.55	3.55	3.55	3.56	3.56	3.56	3.56	3.57	3.57	3.57	3.57
	35	TC	9.46	9.54	9.63	9.72	10.06	10.06	10.06	10.18	10.38	10.38	10.55	10.38	11.21	11.21	11.21	11.21
		S/T	0.80	0.92	1.00	1.00	0.62	0.73	0.85	0.95	0.53	0.64	0.75	0.86	0.34	0.44	0.54	0.65
		PI	3.87	3.87	3.87	3.87	3.89	3.89	3.89	3.89	3.89	3.89	3.90	3.89	3.92	3.92	3.92	3.92
	40	TC	8.62	8.71	8.79	8.88	9.19	9.19	9.24	9.33	9.48	9.48	9.54	9.53	10.27	10.27	10.27	10.27
		S/T	0.83	0.96	1.00	1.00	0.63	0.76	0.88	1.00	0.54	0.66	0.78	0.90	0.33	0.45	0.56	0.90
		PI	4.42	4.42	4.42	4.42	4.44	4.44	4.44	4.44	4.45	4.45	4.46	4.45	4.49	4.49	4.49	4.49
	43	TC	8.17	8.26	8.35	8.43	8.72	8.72	8.80	8.89	9.00	9.00	9.00	9.09	9.77	9.77	9.77	9.77
		S/T	0.85	0.98	1.00	1.00	0.64	0.77	0.90	1.00	0.55	0.67	0.80	0.92	0.33	0.45	0.56	0.92
		PI	4.75	4.75	4.75	4.75	4.77	4.77	4.77	4.77	4.79	4.79	4.79	4.79	4.83	4.83	4.83	4.83

TC:Total Cooling Capacity (kW)
S/T:Sensible Cooling Capacity Ratio
PI:Power Input(kW)

DFMD-100N-01T35+YFAD-100R-01T35																			
INDOOR AIRFLOW (CMH)	OUT-DOOR DB(C)	ID WB (C)	16.0				18.0				19.0				22.0				
		ID DB (C)	23.0	25.0	27.0	29.0	23.0	25.0	27.0	29.0	23.0	25.0	27.0	29.0	23.0	25.0	27.0	29.0	
1149	15	TC	10.66	10.67	10.67	10.78	11.30	11.54	11.54	11.54	11.61	11.61	11.61	11.61	12.46	12.46	12.46	12.46	
		S/T	0.70	0.77	0.84	0.91	0.57	0.64	0.71	0.78	0.51	0.58	0.65	0.71	0.38	0.44	0.50	0.56	
		PI	2.55	2.55	2.55	2.55	2.54	2.54	2.54	2.54	2.54	2.54	2.54	2.54	2.54	2.54	2.54	2.54	2.54
	20	TC	10.54	10.55	10.55	10.66	11.18	11.18	11.18	11.18	11.50	11.50	11.50	11.50	12.36	12.36	12.36	12.36	
		S/T	0.70	0.77	0.84	0.91	0.57	0.64	0.71	0.78	0.51	0.58	0.65	0.71	0.38	0.44	0.50	0.56	
		PI	2.64	2.64	2.64	2.64	2.63	2.63	2.63	2.63	2.63	2.63	2.63	2.63	2.62	2.62	2.62	2.62	
	25	TC	10.06	10.06	10.06	10.17	10.69	10.69	10.69	10.69	11.01	11.01	11.01	11.01	11.84	11.84	11.84	11.84	
		S/T	0.70	0.78	0.85	0.93	0.57	0.64	0.72	0.79	0.51	0.58	0.65	0.72	0.37	0.44	0.50	0.57	
		PI	2.91	2.91	2.91	2.91	2.91	2.91	2.91	2.91	2.91	2.91	2.91	2.91	2.91	2.91	2.91	2.91	
	30	TC	9.57	9.57	9.57	9.66	10.20	10.20	10.20	10.20	10.49	10.49	10.49	10.49	11.32	11.32	11.32	11.32	
		S/T	0.71	0.79	0.87	0.95	0.57	0.65	0.73	0.80	0.51	0.59	0.66	0.73	0.37	0.44	0.50	0.57	
		PI	3.19	3.19	3.19	3.19	3.20	3.20	3.20	3.20	3.20	3.20	3.20	3.20	3.22	3.22	3.22	3.22	
	35	TC	9.11	9.11	9.20	9.28	9.68	9.68	9.68	9.68	10.00	10.00	10.14	10.00	10.78	10.78	10.78	10.78	
		S/T	0.72	0.80	0.88	0.96	0.58	0.66	0.74	0.82	0.51	0.59	0.66	0.74	0.37	0.44	0.51	0.58	
		PI	3.48	3.48	3.48	3.48	3.50	3.50	3.50	3.50	3.51	3.51	3.51	3.51	3.53	3.53	3.53	3.53	
	40	TC	8.37	8.37	8.46	8.55	8.93	8.93	8.93	8.93	9.21	9.21	9.27	9.21	9.95	9.95	9.95	9.95	
		S/T	0.73	0.83	0.92	1.00	0.59	0.67	0.76	0.85	0.52	0.60	0.69	0.77	0.36	0.44	0.51	0.59	
		PI	3.97	3.97	3.97	3.97	3.99	3.99	3.99	3.99	4.00	4.00	4.00	4.00	4.04	4.04	4.04	4.04	
	43	TC	7.93	7.93	8.02	8.10	8.48	8.48	8.48	8.48	8.74	8.74	8.74	8.74	9.46	9.46	9.46	9.46	
		S/T	0.74	0.84	0.93	1.00	0.59	0.68	0.77	0.86	0.52	0.61	0.69	0.78	0.36	0.44	0.52	0.60	
		PI	4.27	4.27	4.27	4.27	4.29	4.29	4.29	4.29	4.30	4.30	4.30	4.30	4.34	4.34	4.34	4.34	
	1372	15	TC	10.87	10.87	10.99	11.11	11.54	11.54	11.54	11.54	11.85	11.85	11.85	11.85	12.73	12.73	12.73	12.73
			S/T	0.72	0.80	0.89	0.97	0.58	0.66	0.74	0.82	0.51	0.59	0.67	0.75	0.36	0.44	0.51	0.58
			PI	2.61	2.61	2.61	2.61	2.60	2.60	2.60	2.60	2.59	2.59	2.59	2.59	2.59	2.59	2.59	2.59
20		TC	10.75	10.75	10.87	10.98	11.41	11.41	11.41	11.41	11.73	11.73	11.73	11.73	12.62	12.62	12.62	12.62	
		S/T	0.72	0.80	0.89	0.97	0.58	0.66	0.74	0.82	0.51	0.59	0.67	0.75	0.36	0.44	0.51	0.58	
		PI	2.70	2.70	2.70	2.70	2.69	2.69	2.69	2.69	2.68	2.68	2.68	2.68	2.67	2.67	2.67	2.67	
25		TC	10.26	10.26	10.38	10.49	10.90	10.90	10.90	10.90	11.21	11.21	11.21	11.21	12.07	12.07	12.07	12.07	
		S/T	0.73	0.82	0.90	0.99	0.58	0.67	0.75	0.84	0.52	0.60	0.68	0.76	0.36	0.44	0.51	0.59	
		PI	2.97	2.97	2.97	2.97	2.96	2.96	2.96	2.96	2.96	2.96	2.96	2.96	2.97	2.97	2.97	2.97	
30		TC	9.77	9.77	9.86	9.95	10.41	10.41	10.41	10.41	10.72	10.72	10.72	10.72	11.53	11.53	11.53	11.53	
		S/T	0.74	0.83	0.92	1.00	0.59	0.68	0.76	0.85	0.52	0.60	0.69	0.77	0.36	0.44	0.52	0.60	
		PI	3.25	3.25	3.25	3.25	3.26	3.26	3.26	3.26	3.27	3.27	3.27	3.27	3.28	3.28	3.28	3.28	
35		TC	9.29	9.29	9.37	9.46	9.89	9.89	9.89	9.89	10.18	10.18	10.35	10.18	10.98	10.98	10.98	10.98	
		S/T	0.75	0.85	0.94	1.00	0.59	0.69	0.78	0.87	0.52	0.61	0.70	0.79	0.35	0.44	0.52	0.60	
		PI	3.55	3.55	3.55	3.55	3.57	3.57	3.57	3.57	3.57	3.57	3.58	3.57	3.57	3.57	3.57	3.57	
40		TC	8.47	8.52	8.61	8.69	9.03	9.03	9.03	9.09	9.30	9.30	9.36	9.30	10.06	10.06	10.06	10.06	
		S/T	0.77	0.88	0.98	1.00	0.60	0.71	0.81	0.91	0.53	0.62	0.72	0.82	0.35	0.44	0.53	0.62	
		PI	4.06	4.06	4.06	4.06	4.08	4.08	4.08	4.08	4.08	4.08	4.09	4.08	4.11	4.11	4.11	4.11	
43		TC	8.03	8.12	8.20	8.29	8.57	8.57	8.57	8.66	8.83	8.83	8.83	8.83	9.57	9.57	9.57	9.57	
		S/T	0.78	0.89	1.00	1.00	0.61	0.72	0.82	0.92	0.53	0.63	0.74	0.84	0.34	0.44	0.53	0.63	
		PI	4.36	4.36	4.36	4.36	4.38	4.38	4.38	4.38	4.39	4.39	4.39	4.39	4.43	4.43	4.43	4.43	

INDOOR AIRFLOW (CMH)	OUT-DOOR DB(C)	ID WB (C)	16.0				18.0				19.0				22.0			
		ID DB (C)	23.0	25.0	27.0	29.0	23.0	25.0	27.0	29.0	23.0	25.0	27.0	29.0	23.0	25.0	27.0	29.0
1804	15	TC	11.08	11.19	11.31	11.43	11.74	11.74	11.74	11.86	12.08	12.08	12.08	12.08	12.96	12.96	12.96	12.96
		S/T	0.78	0.88	0.99	1.00	0.61	0.71	0.81	0.91	0.53	0.63	0.73	0.83	0.35	0.44	0.53	0.63
		PI	2.65	2.65	2.65	2.65	2.65	2.65	2.65	2.65	2.64	2.64	2.64	2.64	2.64	2.64	2.64	2.64
	20	TC	10.95	11.07	11.18	11.30	11.61	11.61	11.61	11.73	11.96	11.96	11.96	11.96	12.85	12.85	12.85	12.85
		S/T	0.78	0.88	0.99	1.00	0.61	0.71	0.81	0.91	0.53	0.63	0.73	0.83	0.35	0.44	0.53	0.63
		PI	2.75	2.75	2.75	2.75	2.74	2.74	2.74	2.74	2.73	2.73	2.73	2.73	2.72	2.72	2.72	2.72
	25	TC	10.46	10.58	10.69	10.81	11.10	11.10	11.10	11.21	11.44	11.44	11.44	11.44	12.30	12.30	12.30	12.30
		S/T	0.79	0.90	1.00	1.00	0.61	0.72	0.83	0.94	0.53	0.64	0.74	0.85	0.34	0.44	0.54	0.64
		PI	3.02	3.02	3.02	3.02	3.02	3.02	3.02	3.02	3.02	3.02	3.02	3.02	3.02	3.02	3.02	3.02
	30	TC	9.98	10.06	10.18	10.29	10.61	10.61	10.61	10.72	10.92	10.92	10.92	10.92	11.76	11.76	11.76	11.76
		S/T	0.80	0.92	1.00	1.00	0.62	0.73	0.85	0.96	0.53	0.65	0.76	0.87	0.34	0.44	0.55	0.65
		PI	3.32	3.32	3.32	3.32	3.32	3.32	3.32	3.32	3.33	3.33	3.33	3.33	3.34	3.34	3.34	3.34
	35	TC	9.46	9.54	9.63	9.72	10.06	10.06	10.06	10.18	10.38	10.38	10.55	10.67	11.21	11.21	11.21	11.21
		S/T	0.82	0.94	1.00	1.00	0.63	0.75	0.87	0.98	0.54	0.66	0.77	0.88	0.34	0.44	0.55	0.66
		PI	3.62	3.62	3.62	3.62	3.64	3.64	3.64	3.64	3.64	3.64	3.65	3.64	3.67	3.67	3.67	3.67
	40	TC	8.62	8.71	8.79	8.88	9.19	9.19	9.24	9.33	9.48	9.48	9.54	9.64	10.27	10.27	10.27	10.27
		S/T	0.85	0.99	1.00	1.00	0.65	0.78	0.91	1.00	0.55	0.68	0.80	0.93	0.33	0.45	0.57	0.90
		PI	4.13	4.13	4.13	4.13	4.15	4.15	4.15	4.15	4.16	4.16	4.17	4.16	4.19	4.19	4.19	4.19
	43	TC	8.17	8.26	8.35	8.43	8.72	8.72	8.80	8.89	9.00	9.00	9.00	9.09	9.77	9.77	9.77	9.77
		S/T	0.87	1.00	1.00	1.00	0.65	0.79	0.93	1.00	0.55	0.69	0.82	0.95	0.33	0.45	0.57	0.92
		PI	4.44	4.44	4.44	4.44	4.46	4.46	4.46	4.46	4.48	4.48	4.48	4.48	4.51	4.51	4.51	4.51

TC:Total Cooling Capacity (kW)
S/T:Sensible Cooling Capacity Ratio
PI:Power Input(kW)

DFMD-140N-01M25																			
INDOOR AIRFLOW (CMH)	OUT-DOOR DB(C)	ID WB (C)	16.0				18.0				19.0				22.0				
		ID DB (C)	23.0	25.0	27.0	29.0	23.0	25.0	27.0	29.0	23.0	25.0	27.0	29.0	23.0	25.0	27.0	29.0	
1400	15	TC	14.18	14.16	14.16	14.16	15.02	15.35	15.35	15.35	15.45	15.45	15.45	15.45	16.59	16.59	16.59	16.59	
		S/T	0.69	0.75	0.82	0.89	0.57	0.63	0.69	0.76	0.51	0.57	0.64	0.70	0.39	0.44	0.50	0.56	
		PI	3.73	3.73	3.73	3.73	3.72	3.72	3.72	3.72	3.72	3.72	3.72	3.72	3.71	3.71	3.71	3.71	
	20	TC	14.02	14.00	14.00	14.00	14.87	14.87	14.87	14.87	15.30	15.30	15.30	15.30	16.44	16.44	16.44	16.44	
		S/T	0.69	0.75	0.82	0.89	0.57	0.63	0.69	0.76	0.51	0.57	0.64	0.70	0.39	0.44	0.50	0.56	
		PI	3.86	3.86	3.86	3.86	3.85	3.85	3.85	3.85	3.84	3.84	3.84	3.84	3.82	3.82	3.82	3.82	
	25	TC	13.37	13.37	13.37	13.52	14.21	14.21	14.21	14.21	14.64	14.64	14.64	14.64	15.73	15.73	15.73	15.73	
		S/T	0.69	0.76	0.83	0.90	0.57	0.64	0.70	0.77	0.51	0.58	0.64	0.70	0.38	0.44	0.50	0.56	
		PI	4.25	4.25	4.25	4.25	4.25	4.25	4.25	4.25	4.25	4.25	4.25	4.25	4.26	4.26	4.26	4.26	
	30	TC	12.74	12.74	12.74	12.86	13.55	13.55	13.55	13.55	13.95	13.95	13.95	13.95	15.04	15.04	15.04	15.04	
		S/T	0.70	0.77	0.84	0.91	0.57	0.64	0.71	0.78	0.51	0.58	0.65	0.71	0.38	0.44	0.50	0.56	
		PI	4.66	4.66	4.66	4.66	4.67	4.67	4.67	4.67	4.67	4.67	4.67	4.67	4.69	4.69	4.69	4.69	
	35	TC	12.11	12.11	12.11	12.23	12.89	12.89	12.89	12.89	13.29	13.29	13.49	13.29	14.32	14.32	14.32	14.32	
		S/T	0.70	0.78	0.86	0.93	0.57	0.65	0.72	0.79	0.51	0.58	0.65	0.72	0.37	0.44	0.50	0.57	
		PI	5.09	5.09	5.09	5.09	5.11	5.11	5.11	5.11	5.12	5.12	5.13	5.12	5.16	5.16	5.16	5.16	
	40	TC	11.13	11.13	11.20	11.32	11.85	11.85	11.85	11.85	12.24	12.24	12.31	12.24	13.23	13.23	13.23	13.23	
		S/T	0.72	0.80	0.88	0.97	0.58	0.66	0.74	0.82	0.51	0.59	0.67	0.75	0.36	0.44	0.51	0.58	
		PI	5.82	5.82	5.82	5.82	5.84	5.84	5.84	5.84	5.85	5.85	5.86	5.85	5.90	5.90	5.90	5.90	
	43	TC	10.55	10.55	10.67	10.78	11.24	11.24	11.24	11.24	11.61	11.61	11.61	11.61	12.59	12.59	12.59	12.59	
		S/T	0.73	0.81	0.90	0.98	0.58	0.66	0.75	0.83	0.51	0.60	0.68	0.76	0.36	0.44	0.51	0.58	
		PI	6.25	6.25	6.25	6.25	6.28	6.28	6.28	6.28	6.29	6.29	6.29	6.29	6.34	6.34	6.34	6.34	
	1800	15	TC	14.49	14.49	14.49	14.63	15.35	15.35	15.35	15.35	15.77	15.77	15.77	15.77	16.94	16.94	16.94	16.94
			S/T	0.72	0.80	0.88	0.96	0.58	0.66	0.74	0.82	0.51	0.59	0.67	0.74	0.36	0.44	0.51	0.58
			PI	3.82	3.82	3.82	3.82	3.80	3.80	3.80	3.80	3.79	3.79	3.79	3.79	3.79	3.79	3.79	3.79
20		TC	14.33	14.33	14.33	14.47	15.19	15.19	15.19	15.19	15.62	15.62	15.62	15.62	16.80	16.80	16.80	16.80	
		S/T	0.72	0.80	0.88	0.96	0.58	0.66	0.74	0.82	0.51	0.59	0.67	0.74	0.36	0.44	0.51	0.58	
		PI	3.95	3.95	3.95	3.95	3.93	3.93	3.93	3.93	3.92	3.92	3.92	3.92	3.90	3.90	3.90	3.90	
25		TC	13.67	13.67	13.81	13.95	14.50	14.50	14.50	14.50	14.93	14.93	14.93	14.93	16.08	16.08	16.08	16.08	
		S/T	0.72	0.81	0.90	0.98	0.58	0.66	0.75	0.83	0.51	0.60	0.68	0.76	0.36	0.44	0.51	0.59	
		PI	4.35	4.35	4.35	4.35	4.34	4.34	4.34	4.34	4.34	4.34	4.34	4.34	4.35	4.35	4.35	4.35	
30		TC	13.01	13.01	13.15	13.29	13.84	13.84	13.84	13.84	14.27	14.27	14.27	14.27	15.36	15.36	15.36	15.36	
		S/T	0.73	0.83	0.91	1.00	0.59	0.67	0.76	0.85	0.52	0.60	0.69	0.77	0.36	0.44	0.51	0.59	
		PI	4.76	4.76	4.76	4.76	4.77	4.77	4.77	4.77	4.77	4.77	4.77	4.77	4.79	4.79	4.79	4.79	
35		TC	12.37	12.37	12.49	12.60	13.15	13.15	13.15	13.15	13.58	13.58	13.78	13.58	14.64	14.64	14.64	14.64	
		S/T	0.74	0.84	0.94	1.00	0.59	0.68	0.77	0.87	0.52	0.61	0.69	0.79	0.35	0.44	0.52	0.60	
		PI	5.20	5.20	5.20	5.20	5.22	5.22	5.22	5.22	5.23	5.23	5.24	5.23	5.23	5.23	5.23	5.23	
40		TC	11.28	11.35	11.46	11.58	12.03	12.03	12.03	12.10	12.42	12.42	12.50	12.42	13.42	13.42	13.42	13.42	
		S/T	0.77	0.87	0.98	1.00	0.60	0.70	0.80	0.90	0.52	0.62	0.72	0.82	0.35	0.44	0.53	0.62	
		PI	5.95	5.95	5.95	5.95	5.97	5.97	5.97	5.97	5.99	5.99	5.99	5.99	6.02	6.02	6.02	6.02	
43		TC	10.68	10.79	10.91	11.02	11.42	11.42	11.42	11.54	11.79	11.79	11.79	11.79	12.76	12.76	12.76	12.76	
		S/T	0.78	0.89	0.99	1.00	0.61	0.71	0.82	0.92	0.53	0.63	0.73	0.83	0.35	0.44	0.53	0.63	
		PI	6.39	6.39	6.39	6.39	6.42	6.42	6.42	6.42	6.44	6.44	6.44	6.44	6.49	6.49	6.49	6.49	

INDOOR AIRFLOW (CMH)	OUT-DOOR DB(C)	ID WB (C)	16.0				18.0				19.0				22.0			
		ID DB (C)	23.0	25.0	27.0	29.0	23.0	25.0	27.0	29.0	23.0	25.0	27.0	29.0	23.0	25.0	27.0	29.0
2150	15	TC	14.78	14.78	14.93	15.07	15.67	15.67	15.67	15.67	16.12	16.12	16.12	16.12	17.29	17.29	17.29	17.29
		S/T	0.75	0.85	0.94	1.00	0.59	0.68	0.78	0.87	0.52	0.61	0.70	0.79	0.35	0.44	0.52	0.60
		PI	3.89	3.89	3.89	3.89	3.88	3.88	3.88	3.88	3.87	3.87	3.87	3.87	3.87	3.87	3.87	3.87
	20	TC	14.61	14.61	14.76	14.90	15.50	15.50	15.50	15.50	15.96	15.96	15.96	15.96	17.14	17.14	17.14	17.14
		S/T	0.75	0.85	0.94	1.00	0.59	0.68	0.78	0.87	0.52	0.61	0.70	0.79	0.35	0.44	0.52	0.60
		PI	4.03	4.03	4.03	4.03	4.01	4.01	4.01	4.01	4.00	4.00	4.00	4.00	3.99	3.99	3.99	3.99
	25	TC	13.95	13.95	14.10	14.24	14.81	14.81	14.81	14.96	15.25	15.25	15.25	15.25	16.42	16.42	16.42	16.42
		S/T	0.76	0.86	0.96	1.00	0.60	0.69	0.79	0.89	0.52	0.62	0.71	0.81	0.35	0.44	0.53	0.61
		PI	4.44	4.44	4.44	4.44	4.44	4.44	4.44	4.44	4.43	4.43	4.43	4.43	4.44	4.44	4.44	4.44
	30	TC	13.29	13.29	13.44	13.58	14.13	14.13	14.13	14.27	14.56	14.56	14.56	14.56	15.68	15.68	15.68	15.68
		S/T	0.77	0.88	0.98	1.00	0.60	0.70	0.81	0.90	0.53	0.62	0.72	0.82	0.35	0.44	0.53	0.62
		PI	4.86	4.86	4.86	4.86	4.87	4.87	4.87	4.87	4.87	4.87	4.87	4.87	4.89	4.89	4.89	4.89
	35	TC	12.63	12.75	12.86	12.98	13.44	13.44	13.44	13.58	13.87	13.87	14.07	13.87	14.96	14.96	14.96	14.96
		S/T	0.78	0.89	1.00	1.00	0.61	0.72	0.82	0.93	0.53	0.63	0.73	0.84	0.34	0.44	0.54	0.63
		PI	5.31	5.31	5.31	5.31	5.33	5.33	5.33	5.33	5.34	5.34	5.35	5.34	5.38	5.38	5.38	5.38
	40	TC	11.52	11.63	11.75	11.86	12.28	12.28	12.28	12.40	12.67	12.67	12.75	12.74	13.70	13.70	13.70	13.70
		S/T	0.81	0.93	1.00	1.00	0.62	0.74	0.86	0.97	0.54	0.65	0.77	0.88	0.34	0.44	0.55	0.90
		PI	6.07	6.07	6.07	6.07	6.09	6.09	6.09	6.09	6.11	6.11	6.11	6.11	6.16	6.16	6.16	6.16
	43	TC	10.91	11.02	11.14	11.25	11.65	11.65	11.65	11.76	12.02	12.02	12.02	12.13	13.02	13.02	13.02	13.02
		S/T	0.83	0.95	1.00	1.00	0.63	0.75	0.88	1.00	0.54	0.66	0.78	0.89	0.34	0.45	0.56	0.92
		PI	6.52	6.52	6.52	6.52	6.55	6.55	6.55	6.55	6.57	6.57	6.57	6.57	6.63	6.63	6.63	6.63

TC:Total Cooling Capacity (kW)
S/T:Sensible Cooling Capacity Ratio
PI:Power Input(kW)

DFMD-160N-01M25																			
INDOOR AIRFLOW (CMH)	OUT-DOOR DB(C)	ID WB (C)	16.0				18.0				19.0				22.0				
		ID DB (C)	23.0	25.0	27.0	29.0	23.0	25.0	27.0	29.0	23.0	25.0	27.0	29.0	23.0	25.0	27.0	29.0	
1490	15	TC	16.27	16.27	16.27	16.27	17.24	17.60	17.60	17.60	17.72	17.72	17.72	17.72	19.03	19.03	19.03	19.03	
		S/T	0.68	0.74	0.80	0.87	0.57	0.62	0.69	0.74	0.52	0.57	0.63	0.69	0.39	0.45	0.50	0.55	
		PI	4.44	4.44	4.44	4.44	4.42	4.42	4.42	4.42	4.42	4.42	4.42	4.42	4.41	4.41	4.41	4.41	
	20	TC	16.09	16.08	16.08	16.08	17.06	17.06	17.06	17.06	17.55	17.55	17.55	17.55	18.87	18.87	18.87	18.87	
		S/T	0.68	0.74	0.80	0.87	0.57	0.63	0.69	0.74	0.52	0.57	0.63	0.69	0.39	0.45	0.50	0.55	
		PI	4.59	4.59	4.59	4.59	4.57	4.57	4.57	4.57	4.56	4.56	4.56	4.56	4.55	4.55	4.55	4.55	
	25	TC	15.34	15.34	15.34	15.34	16.29	16.29	16.29	16.29	16.77	16.77	16.77	16.77	18.07	18.07	18.07	18.07	
		S/T	0.68	0.75	0.81	0.88	0.57	0.63	0.69	0.75	0.51	0.57	0.63	0.69	0.39	0.44	0.50	0.55	
		PI	5.06	5.06	5.06	5.06	5.05	5.05	5.05	5.05	5.05	5.05	5.05	5.05	5.06	5.06	5.06	5.06	
	30	TC	14.62	14.62	14.62	14.76	15.54	15.54	15.54	15.54	16.03	16.03	16.03	16.03	17.26	17.26	17.26	17.26	
		S/T	0.69	0.76	0.82	0.89	0.57	0.63	0.70	0.76	0.51	0.58	0.64	0.70	0.38	0.44	0.50	0.56	
		PI	5.54	5.54	5.54	5.54	5.55	5.55	5.55	5.55	5.56	5.56	5.56	5.56	5.58	5.58	5.58	5.58	
	35	TC	13.90	13.90	13.90	14.05	14.79	14.79	14.79	14.79	15.25	15.25	15.48	15.25	16.46	16.46	16.46	16.46	
		S/T	0.69	0.76	0.84	0.90	0.57	0.64	0.70	0.77	0.51	0.58	0.64	0.71	0.38	0.44	0.50	0.56	
		PI	6.06	6.06	6.06	6.06	6.08	6.08	6.08	6.08	6.09	6.09	6.10	6.09	6.13	6.13	6.13	6.13	
	40	TC	12.80	12.80	12.80	12.93	13.64	13.64	13.64	13.64	14.08	14.08	14.17	14.08	15.22	15.22	15.22	15.22	
		S/T	0.71	0.78	0.86	0.94	0.57	0.65	0.72	0.80	0.51	0.58	0.66	0.73	0.37	0.44	0.50	0.57	
		PI	6.92	6.92	6.92	6.92	6.95	6.95	6.95	6.95	6.97	6.97	6.97	6.97	7.02	7.02	7.02	7.02	
	43	TC	12.13	12.13	12.13	12.25	12.94	12.94	12.94	12.94	13.37	13.37	13.37	13.37	14.46	14.46	14.46	14.46	
		S/T	0.71	0.79	0.88	0.96	0.58	0.65	0.73	0.81	0.51	0.59	0.66	0.74	0.37	0.44	0.51	0.57	
		PI	7.43	7.43	7.43	7.43	7.47	7.47	7.47	7.47	7.49	7.49	7.49	7.49	7.55	7.55	7.55	7.55	
	1850	15	TC	16.62	16.62	16.62	16.80	17.60	17.60	17.60	17.60	18.11	18.11	18.11	18.11	19.42	19.42	19.42	19.42
			S/T	0.70	0.77	0.85	0.92	0.57	0.64	0.71	0.79	0.51	0.58	0.65	0.72	0.37	0.44	0.50	0.57
			PI	4.54	4.54	4.54	4.54	4.52	4.52	4.52	4.52	4.52	4.52	4.52	4.52	4.51	4.51	4.51	4.51
20		TC	16.44	16.44	16.44	16.61	17.41	17.41	17.41	17.41	17.93	17.93	17.93	17.93	19.25	19.25	19.25	19.25	
		S/T	0.70	0.77	0.85	0.92	0.57	0.64	0.71	0.79	0.51	0.58	0.65	0.72	0.37	0.44	0.50	0.57	
		PI	4.69	4.69	4.69	4.69	4.67	4.67	4.67	4.67	4.66	4.66	4.66	4.66	4.65	4.65	4.65	4.65	
25		TC	15.66	15.66	15.66	15.80	16.64	16.64	16.64	16.64	17.13	17.13	17.13	17.13	18.45	18.45	18.45	18.45	
		S/T	0.71	0.78	0.86	0.94	0.57	0.65	0.72	0.80	0.51	0.58	0.66	0.73	0.37	0.44	0.50	0.57	
		PI	5.16	5.16	5.16	5.16	5.16	5.16	5.16	5.16	5.16	5.16	5.16	5.16	5.16	5.16	5.16	5.16	
30		TC	14.91	14.91	14.91	15.06	15.86	15.86	15.86	15.86	16.35	16.35	16.35	16.35	17.61	17.61	17.61	17.61	
		S/T	0.71	0.80	0.88	0.96	0.58	0.65	0.73	0.81	0.51	0.59	0.66	0.74	0.37	0.44	0.51	0.58	
		PI	5.66	5.66	5.66	5.66	5.67	5.67	5.67	5.67	5.67	5.67	5.67	5.67	5.70	5.70	5.70	5.70	
35		TC	14.17	14.17	14.31	14.45	15.09	15.09	15.09	15.09	15.57	15.57	15.80	15.57	16.78	16.78	16.78	16.78	
		S/T	0.72	0.81	0.89	0.98	0.58	0.66	0.74	0.83	0.51	0.59	0.67	0.75	0.36	0.44	0.51	0.58	
		PI	6.19	6.19	6.19	6.19	6.21	6.21	6.21	6.21	6.22	6.22	6.23	6.22	6.22	6.22	6.22	6.22	
40		TC	12.89	12.89	13.01	13.14	13.74	13.74	13.74	13.74	14.19	14.19	14.28	14.19	15.33	15.33	15.33	15.33	
		S/T	0.74	0.84	0.93	1.00	0.59	0.68	0.77	0.86	0.52	0.61	0.69	0.78	0.36	0.44	0.52	0.60	
		PI	7.07	7.07	7.07	7.07	7.10	7.10	7.10	7.10	7.12	7.12	7.12	7.12	7.15	7.15	7.15	7.15	
43		TC	12.22	12.22	12.33	12.44	13.04	13.04	13.04	13.04	13.47	13.47	13.47	13.47	14.57	14.57	14.57	14.57	
		S/T	0.75	0.85	0.95	1.00	0.59	0.69	0.78	0.88	0.52	0.61	0.70	0.79	0.35	0.44	0.52	0.61	
		PI	7.59	7.59	7.59	7.59	7.63	7.63	7.63	7.63	7.65	7.65	7.65	7.65	7.71	7.71	7.71	7.71	

INDOOR AIRFLOW (CMH)	OUT-DOOR DB(C)	ID WB (C)	16.0				18.0				19.0				22.0			
		ID DB (C)	23.0	25.0	27.0	29.0	23.0	25.0	27.0	29.0	23.0	25.0	27.0	29.0	23.0	25.0	27.0	29.0
2400	15	TC	16.94	16.94	17.12	17.29	17.95	17.95	17.95	17.95	18.46	18.46	18.46	18.46	19.82	19.82	19.82	19.82
		S/T	0.74	0.84	0.93	1.00	0.59	0.68	0.77	0.86	0.52	0.61	0.69	0.78	0.35	0.44	0.52	0.60
		PI	4.62	4.62	4.62	4.62	4.61	4.61	4.61	4.61	4.60	4.60	4.60	4.60	4.60	4.60	4.60	4.60
	20	TC	16.75	16.75	16.92	17.10	17.76	17.76	17.76	17.76	18.27	18.27	18.27	18.27	19.65	19.65	19.65	19.65
		S/T	0.74	0.84	0.93	1.00	0.59	0.68	0.77	0.86	0.52	0.61	0.69	0.78	0.35	0.44	0.52	0.60
		PI	4.78	4.78	4.78	4.78	4.76	4.76	4.76	4.76	4.75	4.75	4.75	4.75	4.73	4.73	4.73	4.73
	25	TC	15.98	15.98	16.15	16.32	16.98	16.98	16.98	16.98	17.47	17.47	17.47	17.47	18.79	18.79	18.79	18.79
		S/T	0.75	0.85	0.95	1.00	0.59	0.69	0.78	0.88	0.52	0.61	0.70	0.80	0.35	0.44	0.52	0.61
		PI	5.27	5.27	5.27	5.27	5.27	5.27	5.27	5.27	5.27	5.27	5.27	5.27	5.27	5.27	5.27	5.27
	30	TC	15.23	15.23	15.37	15.52	16.18	16.18	16.18	16.35	16.69	16.69	16.69	16.69	17.99	17.99	17.99	17.99
		S/T	0.76	0.87	0.97	1.00	0.60	0.70	0.80	0.89	0.52	0.62	0.72	0.81	0.35	0.44	0.53	0.62
		PI	5.77	5.77	5.77	5.77	5.79	5.79	5.79	5.79	5.79	5.79	5.79	5.79	5.82	5.82	5.82	5.82
	35	TC	14.45	14.60	14.74	14.88	15.40	15.40	15.40	15.54	15.86	15.86	16.12	15.86	17.13	17.13	17.13	17.13
		S/T	0.78	0.89	0.99	1.00	0.61	0.71	0.82	0.92	0.53	0.63	0.73	0.83	0.35	0.44	0.53	0.63
		PI	6.31	6.31	6.31	6.31	6.34	6.34	6.34	6.34	6.35	6.35	6.36	6.35	6.39	6.39	6.39	6.39
	40	TC	13.15	13.28	13.40	13.53	14.02	14.02	14.02	14.16	14.47	14.47	14.57	14.56	15.65	15.65	15.65	15.65
		S/T	0.81	0.92	1.00	1.00	0.62	0.74	0.85	0.96	0.53	0.65	0.76	0.87	0.34	0.44	0.54	0.90
		PI	7.21	7.21	7.21	7.21	7.25	7.25	7.25	7.25	7.26	7.26	7.27	7.26	7.31	7.31	7.31	7.31
	43	TC	12.47	12.59	12.70	12.81	13.30	13.30	13.30	13.44	13.75	13.75	13.75	13.89	14.89	14.89	14.89	14.89
		S/T	0.82	0.94	1.00	1.00	0.63	0.75	0.87	0.98	0.54	0.65	0.77	0.88	0.34	0.44	0.55	0.92
		PI	7.75	7.75	7.75	7.75	7.79	7.79	7.79	7.79	7.81	7.81	7.81	7.81	7.87	7.87	7.87	7.87

TC:Total Cooling Capacity (kW)
S/T:Sensible Cooling Capacity Ratio
PI:Power Input(kW)

7.2 Heating

DFMD-100N-01M25+FFMD-100N-01M25								[SI_Unit]	
INDOOR AIRFLOW (CMH)	HEATING PERFORMANCE AT INDOOR DRY BULB TEMPERATURE								
	OUTDOOR DB(°C)	TC:TOTAL CAPACITY IN KILOWATTS (KW)				PI:TOTAL POWER IN KILOWATTS (KW)			
		Indoor Conditions (DB °C)				Indoor Conditions (DB °C)			
		16.0	20.0	22.0	24.0	16.0	20.0	22.0	24.0
1160	-7.0	7.39	7.31	7.26	7.23	2.31	2.37	2.47	2.53
	-5.6	7.83	7.75	7.69	7.66	2.38	2.49	2.55	2.61
	-2.8	8.27	8.15	8.10	8.04	2.53	2.65	2.71	2.78
	0.0	8.56	8.44	8.39	8.33	2.68	2.81	2.88	2.94
	2.8	9.20	9.08	9.02	8.97	2.87	3.01	3.08	3.15
	5.6	10.18	10.04	9.98	9.92	3.05	3.20	3.28	3.35
	7.0	11.24	11.08	10.76	10.68	3.16	3.43	3.39	3.45
	11.1	11.92	11.75	11.66	11.60	3.41	3.56	3.65	3.73
	13.9	12.56	12.39	12.30	12.21	3.57	3.74	3.83	3.91
	16.7	13.20	13.03	12.94	12.85	3.74	3.92	4.01	4.10
18.0	13.49	13.32	13.23	13.14	3.82	4.01	4.10	4.19	
1383	-7.0	7.55	7.47	7.41	7.36	2.34	2.39	2.50	2.55
	-5.6	8.01	7.92	7.86	7.81	2.41	2.52	2.57	2.63
	-2.8	8.44	8.33	8.27	8.21	2.55	2.68	2.74	2.80
	0.0	8.76	8.65	8.56	8.50	2.70	2.84	2.90	2.97
	2.8	9.40	9.28	9.23	9.14	2.89	3.03	3.10	3.18
	5.6	10.39	10.27	10.18	10.13	3.08	3.23	3.30	3.38
	7.0	11.44	11.31	10.97	10.91	3.19	3.46	3.41	3.48
	11.1	12.16	12.01	11.92	11.84	3.43	3.59	3.68	3.76
	13.9	12.82	12.65	12.56	12.47	3.60	3.77	3.86	3.95
	16.7	13.46	13.29	13.20	13.11	3.77	3.95	4.04	4.13
18.0	13.78	13.61	13.49	13.40	3.85	4.04	4.13	4.22	
1836	-7.0	7.65	7.54	7.52	7.46	2.36	2.42	2.52	2.58
	-5.6	8.10	7.98	7.95	7.89	2.42	2.54	2.60	2.66
	-2.8	8.53	8.41	8.36	8.30	2.58	2.71	2.77	2.83
	0.0	8.85	8.73	8.68	8.59	2.73	2.87	2.94	3.00
	2.8	9.49	9.37	9.31	9.26	2.92	3.07	3.14	3.21
	5.6	10.50	10.36	10.30	10.21	3.12	3.27	3.34	3.41
	7.0	11.59	11.43	11.08	11.02	3.22	3.50	3.45	3.52
	11.1	12.27	12.13	12.04	11.95	3.47	3.64	3.72	3.80
	13.9	12.94	12.76	12.68	12.59	3.64	3.82	3.91	3.99
	16.7	13.61	13.43	13.34	13.23	3.81	4.00	4.09	4.18
18.0	13.93	13.75	13.64	13.55	3.90	4.09	4.18	4.27	

DFMD-100N-01M25+YFAD-100R-01M25								[SI_Unit]	
INDOOR AIRFLOW (CMH)	HEATING PERFORMANCE AT INDOOR DRY BULB TEMPERATURE								
	OUTDOOR DB(°C)	TC:TOTAL CAPACITY IN KILOWATTS (KW)				PI:TOTAL POWER IN KILOWATTS (KW)			
		Indoor Conditions (DB °C)				Indoor Conditions (DB °C)			
		16.0	20.0	22.0	24.0	16.0	20.0	22.0	24.0
950	-7.0	7.39	7.31	7.26	7.23	2.51	2.57	2.69	2.75
	-5.6	7.83	7.75	7.69	7.66	2.58	2.71	2.77	2.84
	-2.8	8.27	8.15	8.10	8.04	2.75	2.88	2.95	3.02
	0.0	8.56	8.44	8.39	8.33	2.91	3.05	3.13	3.20
	2.8	9.20	9.08	9.02	8.97	3.11	3.26	3.33	3.41
	5.6	10.18	10.04	9.98	9.92	3.30	3.46	3.54	3.62
	7.0	11.24	11.08	10.76	10.68	3.42	3.72	3.66	3.75
	11.1	11.92	11.75	11.66	11.60	3.69	3.86	3.95	4.04
	13.9	12.56	12.39	12.30	12.21	3.87	4.05	4.15	4.24
	16.7	13.20	13.03	12.94	12.85	4.05	4.25	4.34	4.43
18.0	13.49	13.32	13.23	13.14	4.14	4.34	4.43	4.53	
1280	-7.0	7.55	7.47	7.41	7.36	2.53	2.59	2.71	2.78
	-5.6	8.01	7.92	7.86	7.81	2.61	2.73	2.80	2.86
	-2.8	8.44	8.33	8.27	8.21	2.77	2.91	2.98	3.05
	0.0	8.76	8.65	8.56	8.50	2.94	3.08	3.16	3.23
	2.8	9.40	9.28	9.23	9.14	3.14	3.29	3.36	3.44
	5.6	10.39	10.27	10.18	10.13	3.34	3.50	3.58	3.66
	7.0	11.44	11.31	10.97	10.91	3.45	3.76	3.70	3.79
	11.1	12.16	12.01	11.92	11.84	3.73	3.91	4.00	4.09
	13.9	12.82	12.65	12.56	12.47	3.91	4.10	4.19	4.29
	16.7	13.46	13.29	13.20	13.11	4.10	4.29	4.39	4.48
18.0	13.78	13.61	13.49	13.40	4.19	4.39	4.48	4.58	
1700	-7.0	7.65	7.54	7.52	7.46	2.56	2.62	2.74	2.81
	-5.6	8.10	7.98	7.95	7.89	2.63	2.76	2.83	2.89
	-2.8	8.53	8.41	8.36	8.30	2.80	2.94	3.01	3.08
	0.0	8.85	8.73	8.68	8.59	2.97	3.12	3.19	3.26
	2.8	9.49	9.37	9.31	9.26	3.18	3.32	3.40	3.48
	5.6	10.50	10.36	10.30	10.21	3.37	3.54	3.62	3.70
	7.0	11.59	11.43	11.08	11.02	3.49	3.80	3.74	3.83
	11.1	12.27	12.13	12.04	11.95	3.77	3.95	4.04	4.13
	13.9	12.94	12.76	12.68	12.59	3.95	4.14	4.24	4.33
	16.7	13.61	13.43	13.34	13.23	4.14	4.34	4.43	4.53
18.0	13.93	13.75	13.64	13.55	4.23	4.42	4.53	4.63	

DFMD-100N-01T35+YFAD-100R-01T35								[SI_Unit]	
INDOOR AIRFLOW (CMH)	HEATING PERFORMANCE AT INDOOR DRY BULB TEMPERATURE								
	OUTDOOR DB(°C)	TC:TOTAL CAPACITY IN KILOWATTS (KW)				PI:TOTAL POWER IN KILOWATTS (KW)			
		Indoor Conditions (DB °C)				Indoor Conditions (DB °C)			
		16.0	20.0	22.0	24.0	16.0	20.0	22.0	24.0
1149	-7.0	6.88	6.80	6.74	6.72	2.78	2.86	2.91	2.95
	-5.6	7.41	7.32	7.26	7.23	2.79	2.88	2.93	2.97
	-2.8	7.93	7.81	7.76	7.70	2.84	2.93	2.97	3.02
	0.0	8.31	8.19	8.13	8.07	2.88	2.97	3.02	3.07
	2.8	9.03	8.92	8.86	8.80	2.96	3.05	3.10	3.15
	5.6	10.11	9.96	9.90	9.85	3.03	3.13	3.18	3.23
	7.0	11.24	11.08	10.70	10.65	3.08	3.24	3.23	3.28
	11.1	12.01	11.84	11.75	11.69	3.17	3.27	3.33	3.38
	13.9	12.74	12.56	12.47	12.39	3.23	3.34	3.39	3.44
	16.7	13.46	13.29	13.20	13.11	3.29	3.40	3.44	3.50
18.0	13.81	13.64	13.52	13.43	3.32	3.42	3.48	3.53	
1372	-7.0	7.05	6.94	6.88	6.86	2.81	2.89	2.94	2.98
	-5.6	7.58	7.46	7.41	7.38	2.82	2.91	2.96	3.00
	-2.8	8.07	7.99	7.93	7.87	2.86	2.96	3.00	3.05
	0.0	8.48	8.37	8.31	8.25	2.91	3.00	3.05	3.10
	2.8	9.24	9.12	9.03	8.98	2.98	3.08	3.13	3.18
	5.6	10.31	10.20	10.11	10.05	3.06	3.16	3.21	3.26
	7.0	11.44	11.31	10.94	10.85	3.11	3.27	3.26	3.31
	11.1	12.24	12.10	12.01	11.92	3.20	3.30	3.36	3.41
	13.9	13.00	12.82	12.74	12.65	3.26	3.37	3.41	3.47
	16.7	13.75	13.55	13.46	13.37	3.32	3.42	3.48	3.53
18.0	14.10	13.90	13.81	13.72	3.34	3.45	3.51	3.56	
1804	-7.0	7.08	7.00	6.95	6.89	2.84	2.92	2.97	3.02
	-5.6	7.64	7.55	7.49	7.44	2.85	2.94	2.99	3.03
	-2.8	8.16	8.05	7.99	7.96	2.89	2.99	3.03	3.08
	0.0	8.57	8.45	8.39	8.34	2.94	3.03	3.08	3.13
	2.8	9.32	9.21	9.12	9.06	3.01	3.11	3.16	3.21
	5.6	10.43	10.28	10.22	10.14	3.09	3.19	3.24	3.29
	7.0	11.59	11.43	11.05	10.97	3.14	3.30	3.29	3.34
	11.1	12.39	12.21	12.13	12.04	3.23	3.33	3.39	3.43
	13.9	13.14	12.97	12.88	12.79	3.29	3.40	3.44	3.50
	16.7	13.90	13.69	13.61	13.52	3.34	3.45	3.51	3.56
18.0	14.24	14.07	13.95	13.87	3.37	3.48	3.54	3.59	

DFMD-140N-01M25+YFAD-140R-01T35								[SI_Unit]	
INDOOR AIRFLOW (CMH)	HEATING PERFORMANCE AT INDOOR DRY BULB TEMPERATURE								
	OUTDOOR DB(°C)	TC:TOTAL CAPACITY IN KILOWATTS (KW)				PI:TOTAL POWER IN KILOWATTS (KW)			
		Indoor Conditions (DB °C)				Indoor Conditions (DB °C)			
		16.0	20.0	22.0	24.0	16.0	20.0	22.0	24.0
1400	-7.0	9.09	8.96	8.91	8.83	3.93	4.03	4.11	4.18
	-5.6	9.94	9.80	9.74	9.65	3.96	4.08	4.15	4.22
	-2.8	10.76	10.61	10.52	10.44	4.03	4.17	4.24	4.31
	0.0	11.39	11.25	11.16	11.08	4.12	4.26	4.34	4.41
	2.8	12.53	12.35	12.26	12.18	4.25	4.40	4.48	4.55
	5.6	14.15	13.95	13.86	13.74	4.38	4.54	4.62	4.69
	7.0	15.85	15.63	15.05	14.96	4.46	4.72	4.70	4.78
	11.1	17.02	16.79	16.70	16.58	4.62	4.79	4.87	4.95
	13.9	18.15	17.92	17.80	17.69	4.73	4.90	4.99	5.06
	16.7	19.28	19.02	18.90	18.79	4.84	5.02	5.09	5.18
18.0	19.83	19.57	19.42	19.31	4.89	5.06	5.15	5.24	
1800	-7.0	9.28	9.15	9.10	9.02	3.97	4.08	4.16	4.23
	-5.6	10.15	10.00	9.94	9.86	4.00	4.13	4.20	4.26
	-2.8	10.96	10.81	10.76	10.67	4.08	4.22	4.29	4.36
	0.0	11.66	11.48	11.39	11.31	4.16	4.31	4.38	4.45
	2.8	12.79	12.61	12.53	12.44	4.29	4.44	4.52	4.60
	5.6	14.44	14.24	14.12	14.03	4.43	4.58	4.66	4.74
	7.0	16.17	15.95	15.37	15.25	4.51	4.76	4.75	4.82
	11.1	17.37	17.13	17.02	16.90	4.67	4.83	4.92	5.00
	13.9	18.53	18.26	18.15	18.03	4.78	4.95	5.03	5.11
	16.7	19.66	19.42	19.28	19.16	4.88	5.05	5.14	5.23
18.0	20.24	19.95	19.83	19.69	4.94	5.11	5.20	5.29	
2150	-7.0	9.38	9.25	9.17	9.12	4.01	4.12	4.21	4.27
	-5.6	10.26	10.12	10.03	9.97	4.03	4.17	4.24	4.31
	-2.8	11.10	10.93	10.87	10.79	4.12	4.26	4.33	4.40
	0.0	11.77	11.60	11.51	11.42	4.20	4.35	4.42	4.50
	2.8	12.93	12.76	12.67	12.58	4.34	4.49	4.57	4.64
	5.6	14.58	14.38	14.29	14.18	4.47	4.63	4.71	4.78
	7.0	16.35	16.12	15.51	15.42	4.55	4.81	4.79	4.87
	11.1	17.57	17.34	17.22	17.11	4.71	4.88	4.96	5.04
	13.9	18.73	18.47	18.35	18.24	4.82	4.99	5.07	5.15
	16.7	19.89	19.63	19.51	19.37	4.93	5.10	5.18	5.27
18.0	20.44	20.18	20.03	19.92	4.98	5.15	5.24	5.33	

DFMD-160N-01M25								[SI_Unit]	
INDOOR AIRFLOW (CMH)	HEATING PERFORMANCE AT INDOOR DRY BULB TEMPERATURE								
	OUTDOOR DB(°C)	TC:TOTAL CAPACITY IN KILOWATTS (KW)				PI:TOTAL POWER IN KILOWATTS (KW)			
		Indoor Conditions (DB °C)				Indoor Conditions (DB °C)			
		16.0	20.0	22.0	24.0	16.0	20.0	22.0	24.0
1490	-7.0	9.28	9.15	9.10	9.02	4.54	4.67	4.77	4.84
	-5.6	10.31	10.17	10.11	10.02	4.57	4.73	4.81	4.87
	-2.8	11.33	11.15	11.07	10.98	4.67	4.83	4.90	4.98
	0.0	12.14	11.97	11.88	11.79	4.76	4.92	5.00	5.08
	2.8	13.48	13.30	13.19	13.10	4.90	5.07	5.16	5.24
	5.6	15.33	15.13	15.02	14.93	5.05	5.22	5.31	5.40
	7.0	17.29	17.06	16.37	16.28	5.14	5.43	5.41	5.50
	11.1	18.69	18.46	18.34	18.19	5.32	5.50	5.59	5.68
	13.9	20.02	19.76	19.65	19.53	5.44	5.62	5.72	5.82
	16.7	21.39	21.10	20.95	20.84	5.55	5.75	5.85	5.95
18.0	22.02	21.73	21.59	21.44	5.61	5.81	5.91	6.01	
1850	-7.0	9.46	9.32	9.25	9.19	4.58	4.71	4.81	4.88
	-5.6	10.51	10.37	10.28	10.22	4.62	4.78	4.85	4.92
	-2.8	11.53	11.38	11.30	11.21	4.71	4.87	4.95	5.03
	0.0	12.40	12.20	12.11	12.02	4.81	4.97	5.05	5.14
	2.8	13.77	13.56	13.48	13.36	4.95	5.12	5.21	5.30
	5.6	15.65	15.45	15.33	15.22	5.10	5.28	5.37	5.46
	7.0	17.64	17.41	16.71	16.60	5.19	5.49	5.47	5.55
	11.1	19.06	18.83	18.72	18.57	5.38	5.56	5.65	5.75
	13.9	20.46	20.17	20.05	19.91	5.50	5.69	5.79	5.88
	16.7	21.82	21.53	21.39	21.27	5.61	5.82	5.92	6.02
18.0	22.46	22.20	22.05	21.91	5.67	5.88	5.98	6.08	
2400	-7.0	9.57	9.41	9.36	9.28	4.62	4.76	4.86	4.93
	-5.6	10.63	10.46	10.40	10.31	4.66	4.82	4.89	4.97
	-2.8	11.65	11.47	11.38	11.33	4.76	4.91	5.00	5.08
	0.0	12.52	12.31	12.23	12.14	4.86	5.02	5.10	5.19
	2.8	13.88	13.68	13.59	13.51	5.00	5.18	5.27	5.35
	5.6	15.80	15.60	15.48	15.36	5.16	5.34	5.43	5.52
	7.0	17.81	17.58	16.89	16.77	5.25	5.54	5.52	5.61
	11.1	19.27	19.01	18.89	18.77	5.44	5.62	5.72	5.81
	13.9	20.66	20.40	20.25	20.11	5.55	5.75	5.85	5.95
	16.7	22.02	21.76	21.62	21.47	5.68	5.88	5.99	6.09
18.0	22.69	22.40	22.26	22.11	5.74	5.95	6.05	6.15	

8. Capacity Correction Factor for Height Difference

8.1 Heat pump models

Model	18K		Pipe Length (m)			
Cooling			5	10	15	25
Height difference H (m)	Indoor Upper than Outdoor	/	/	/	/	/
		15	/	/	0.915	0.861
		10	/	0.957	0.929	0.874
		5	0.995	0.967	0.939	0.883
		0	1.000	0.972	0.944	0.887
	Outdoor Upper than Indoor	-5	1.000	0.972	0.944	0.887
		-10	/	0.972	0.944	0.887
		-15	/	/	0.944	0.887
		/	/	/	/	/
	Heating			5	10	15
Height difference H (m)	Indoor Upper than Outdoor	/	/	/	/	/
		15	/	/	0.977	0.953
		10	/	0.988	0.977	0.953
		5	1.000	0.988	0.977	0.953
		0	1.000	0.988	0.977	0.953
	Outdoor Upper than Indoor	-5	0.992	0.980	0.969	0.945
		-10	/	0.973	0.961	0.938
		-15	/	/	0.953	0.930
		/	/	/	/	/

Model	24K		Pipe Length (m)			
Cooling			5	10	15	25
Height difference H (m)	Indoor Upper than Outdoor	/	/	/	/	/
		15	/	/	0.900	0.830
		10	/	0.949	0.914	0.842
		5	0.995	0.959	0.923	0.851
		0	1.000	0.964	0.928	0.855
	Outdoor Upper than Indoor	-5	1.000	0.964	0.928	0.855
		-10	/	0.964	0.928	0.855
		-15	/	/	0.928	0.855
		/	/	/	/	/
	Heating			5	10	15
Height difference H (m)	Indoor Upper than Outdoor	/	/	/	/	/
		15	/	/	0.973	0.946
		10	/	0.987	0.973	0.946
		5	1.000	0.987	0.973	0.946
		0	1.000	0.987	0.973	0.946
	Outdoor Upper than Indoor	-5	0.992	0.979	0.965	0.938
		-10	/	0.971	0.957	0.931
		-15	/	/	0.950	0.923
		/	/	/	/	/

Model	36K		Pipe Length (m)						
Cooling			5	10	15	20	25	30	
Height difference H (m)	Indoor Upper than Outdoor	20				0.820	0.775	0.729	
		15			0.878	0.832	0.786	0.740	
		10		0.938	0.892	0.845	0.798	0.752	
		5	0.995	0.948	0.901	0.854	0.806	0.759	
	0		1.000	0.953	0.905	0.858	0.810	0.763	
	Outdoor Upper than Indoor	-5	1.000	0.953	0.905	0.858	0.810	0.763	
		-10		0.953	0.905	0.858	0.810	0.763	
		-15			0.905	0.858	0.810	0.763	
		-20				0.858	0.810	0.763	
	Heating			5	10	15	20	25	30
	Height difference H (m)	Indoor Upper than Outdoor	20				0.935	0.914	0.892
			15			0.957	0.935	0.914	0.892
10				0.978	0.957	0.935	0.914	0.892	
5			1.000	0.978	0.957	0.935	0.914	0.892	
0		1.000	0.978	0.957	0.935	0.914	0.892		
Outdoor Upper than Indoor		-5	0.992	0.971	0.949	0.928	0.906	0.885	
		-10		0.963	0.942	0.920	0.899	0.878	
		-15			0.934	0.913	0.892	0.871	
		-20				0.906	0.885	0.864	

Model	48K		Pipe Length (m)					
Cooling			5	10	20	30	40	50
Height difference H (m)	Indoor Upper than Outdoor	30				0.808	0.749	0.690
		20			0.880	0.820	0.760	0.701
		10		0.955	0.894	0.833	0.772	0.711
		5	0.995	0.964	0.903	0.841	0.780	0.718
	0		1.000	0.969	0.907	0.846	0.784	0.722
	Outdoor Upper than Indoor	-5	1.000	0.969	0.907	0.846	0.784	0.722
		-10		0.969	0.907	0.846	0.784	0.722
		-20			0.907	0.846	0.784	0.722
		-30				0.846	0.784	0.722
	Heating			5	10	20	30	40
Height difference H (m)	Indoor Upper than Outdoor	30				0.929	0.901	0.873
		20			0.958	0.929	0.901	0.873
		10		0.986	0.958	0.929	0.901	0.873
		5	1.000	0.986	0.958	0.929	0.901	0.873
	0		1.000	0.986	0.958	0.929	0.901	0.873
	Outdoor Upper than Indoor	-5	0.992	0.978	0.950	0.922	0.894	0.866
		-10		0.970	0.942	0.915	0.887	0.859
		-20			0.935	0.907	0.880	0.852
		-30				0.900	0.873	0.845

Model	60K		Pipe Length (m)					
Cooling			5	10	20	30	40	50
Height difference H (m)	Indoor Upper than Outdoor	30				0.772	0.698	0.625
		20			0.858	0.784	0.709	0.634
		10		0.947	0.871	0.796	0.720	0.644
		5	0.995	0.957	0.880	0.804	0.727	0.650
	0		1.000	0.962	0.885	0.808	0.731	0.654
	Outdoor Upper than Indoor	-5	1.000	0.962	0.885	0.808	0.731	0.654
		-10		0.962	0.885	0.808	0.731	0.654
		-20			0.885	0.808	0.731	0.654
		-30				0.808	0.731	0.654
	Heating			5	10	20	30	40
Height difference H (m)	Indoor Upper than Outdoor	30				0.909	0.872	0.836
		20			0.945	0.909	0.872	0.836
		10		0.982	0.945	0.909	0.872	0.836
		5	1.000	0.982	0.945	0.909	0.872	0.836
	0		1.000	0.982	0.945	0.909	0.872	0.836
	Outdoor Upper than Indoor	-5	0.992	0.974	0.938	0.902	0.865	0.829
		-10		0.966	0.930	0.894	0.858	0.823
		-20			0.923	0.887	0.852	0.816
		-30				0.880	0.845	0.810

9. Noise Criterion Curves

9.1 Indoor Unit

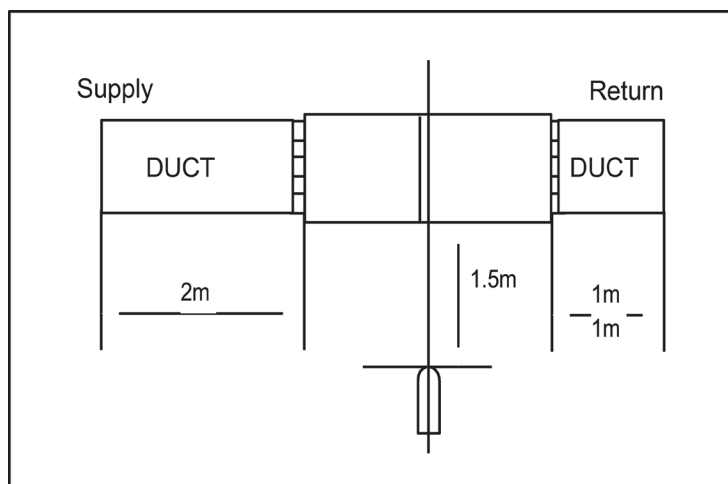

Notes:

- Sound measured at 1.5m away from the center of the unit.
- Data is valid at free field condition
- Data is valid at nominal operation condition
- Reference acoustic pressure $OdB = 20\mu Pa$
- Sound level will vary depending on a range of factors such as the construction -(acoustic absorption coefficient) of particular room in which the equipment is installed.
- The operating conditions are assumed to be standard.

Model	Noise level dB(A)		
	H	M	L
DFMD-100N-01M25	49	43	40
DFMD-100N-01T35	47	40.5	38
DFMD-140N-01M25	49	45	41
DFMD-160N-01M25	53	47	44

9.2 Outdoor Unit

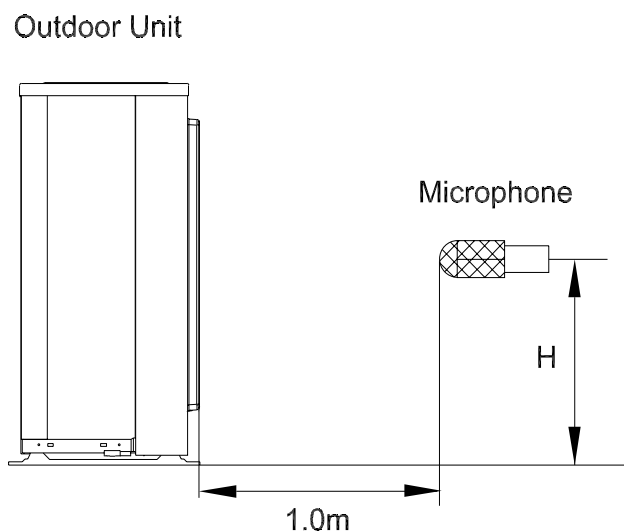

Note: $H = 0.5 \times$ height of outdoor unit

Notes:

- Sound measured at 1.0m away from the center of the unit.
- Data is valid at free field condition
- Data is valid at nominal operation condition
- Reference acoustic pressure $OdB=20\mu Pa$
- Sound level will vary depending on arrange off actors such as the construction (acoustic absorption coefficient) of particular room in which the equipment is installed.
- The operating conditions are assumed to be standard.

Model	Noise level dB(A)
YFAD-100R-01M25	63
YFAD-100R-01T35	63
YFAD-140R-01T35	63
YFAD-160R-01T35	62.8

10. Electrical Characteristics

10.1 Heat pump models

Type		18000 Btu/h	24000 Btu/h	36000 Btu/h
Phase		1-phase	1-phase	1-phase
Frequency and Voltage		220-240V, 50Hz	220-240V~,50Hz	220-240V, 50Hz
Circuit Breaker/ Fuse (A)		25/20	32/25	50/40
Indoor Unit Power Wiring (mm ²)		3×2.5	3×2.5	
Outdoor Unit Power Wiring (mm ²)				3×4.0
Indoor/Outdoor Connecting Wiring (mm ²)	Ground Wiring	2.5	2.5	4.0
	Strong Electric Signal	2×1.0/3×2.5	3×1.0/3×2.5	3×1.0/3×1.5
	Weak Electric Signal	(2×0.75/2×0.5)	(2×0.2)	(2×0.2)

Type		36000 Btu/h	48000 Btu/h	60000 Btu/h
Phase		3-phase	3-phase	3-phase
Frequency and Voltage		380-415V, 50Hz	380-415V, 50Hz	380-415V, 50Hz
Circuit Breaker/ Fuse (A)		25/20	32/25	32/25
Indoor Unit Power Wiring (mm ²)			5×2.5	5×2.5
Outdoor Unit Power Wiring (mm ²)		5×2.5		
Indoor/Outdoor Connecting Wiring (mm ²)	Ground Wiring	2.5	2.5	2.5
	Strong Electric Signal	3×1.0/3×1.5	3×1.0/5×2.5	3×1.0/5×2.5
	Weak Electric Signal			

11. Static Pressure

18K

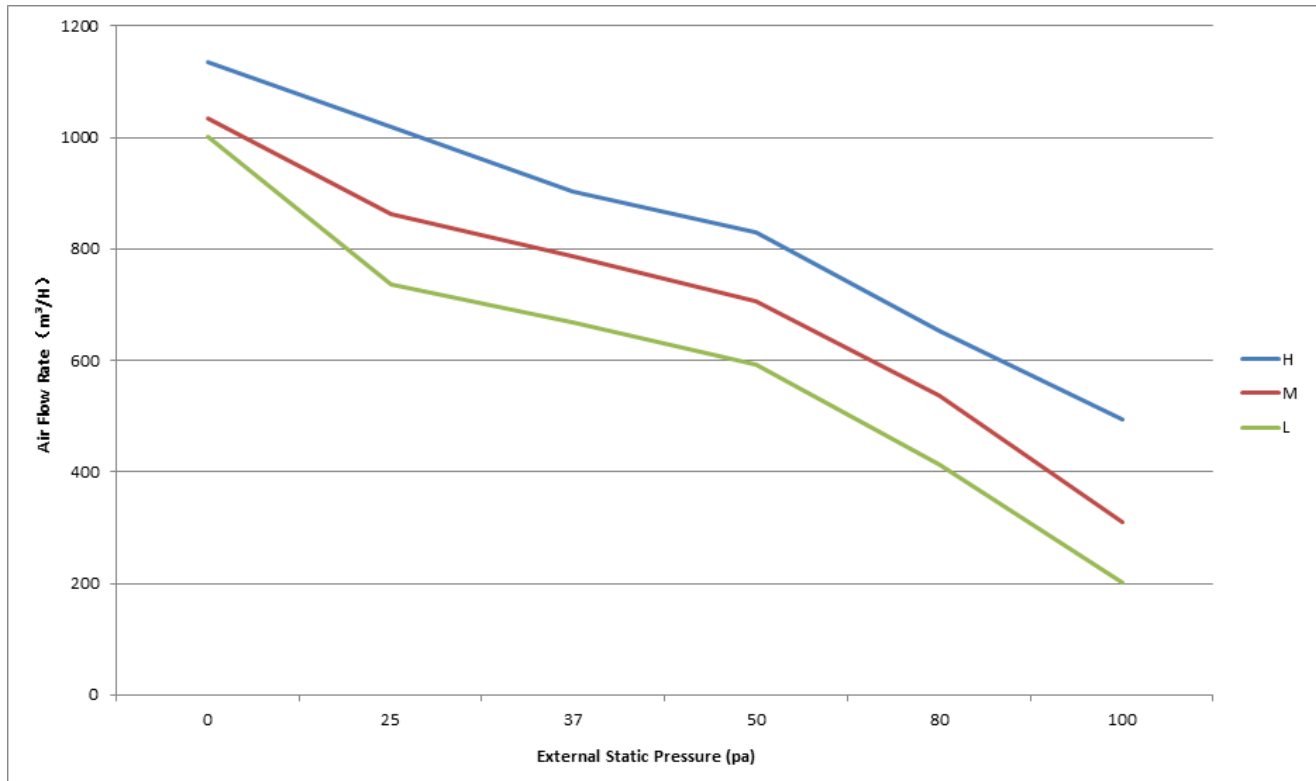

24K

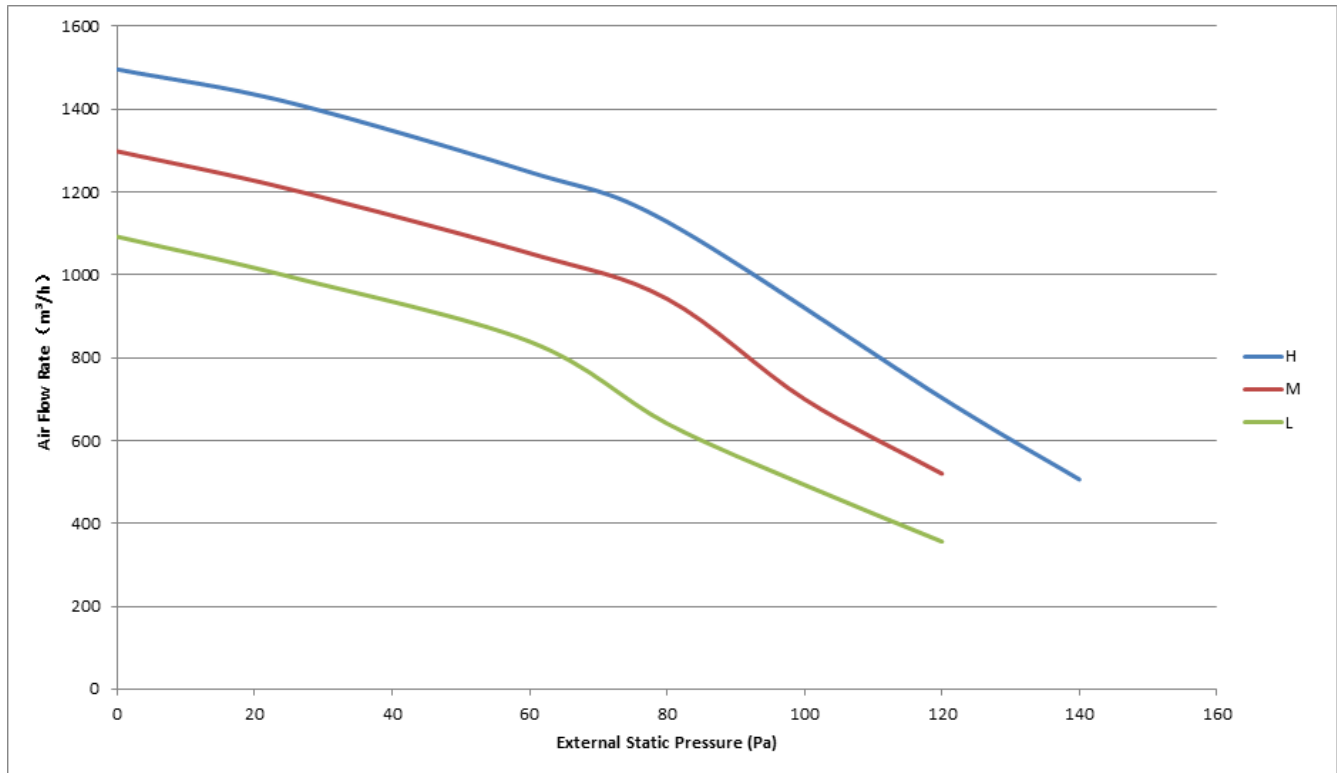

30K/36K

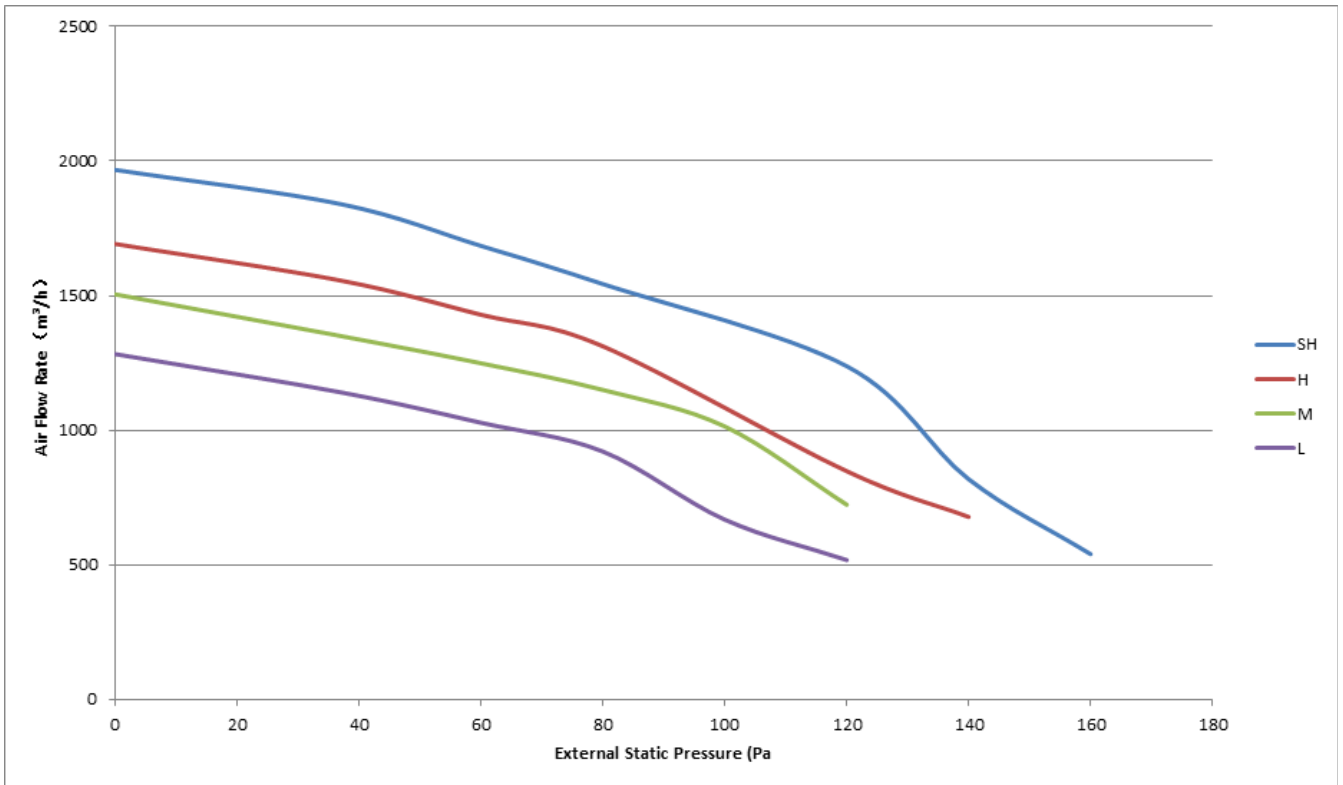

48K/60K

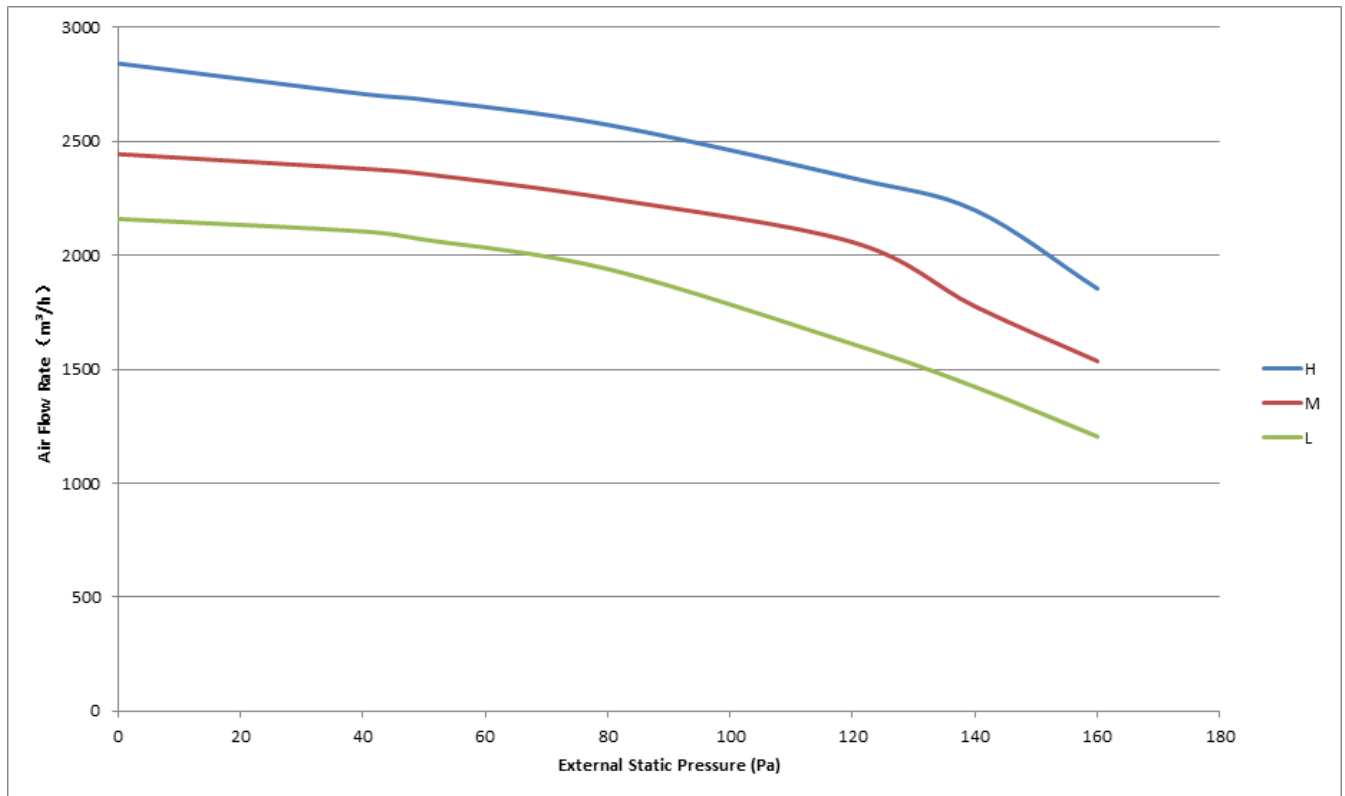

Product Features

Contents

1.	Operation Modes and Functions	59
1.1	Abbreviations	59
1.2	Safety Features	59
1.3	Display Function	59
1.4	Fan.....	59
1.5	Cooling Mode	59
1.6	Heating Mode	59
1.7	Auto Mode.....	60
1.8	Drying Mode	60
1.9	Timer Function	60
1.10	Sleep Function.....	60
1.11	Auto-Restart.....	61
1.12	Follow Me	61
1.13	Drain Pump Control.....	61
2.	Remote Controller Functions	62
2.1	LCD Wired Remote Controller	62
2.2	Centralized Controller	74

1. Operation Modes and Functions

1.1 Abbreviation

Unit element abbreviations

Abbreviation	Element
T1	Indoor room temperature
T2	Coil temperature of evaporator
T3	Coil temperature of condenser
T4	Outdoor ambient temperature
T5	Compressor discharge temperature

1.2 Safety Features

Compressor three-minute delay at restart

Compressor functions are delayed for up to one minute upon the first startup of the unit, and are delayed for up to three minutes upon subsequent unit restarts.

Phase Check Function(for 3 phase models)

If the phase sequence is detected wrong or lack of 1 or 2 phase, the unit won't start and there is error code displayed on outdoor PCB.

Low Pressure Check Function(For 36K~60K)

The low pressure switch should be always closed. If it is open, the system will stop until the fault is cleared. During defrosting procedure , 4 minutes after defrosting ends and 5 minutes after compressor is on in heating mode, low pressure switch won't be checked.

Note: The system will not check if the protection could be cleared in 30 seconds after the protection occurs. If this protection occurs 3 times, it won't recover automatically until the main power is cut off.

Over-current protection

When compressor is running, if the current is over twice of the rated for 3 seconds, the compressor will stop and an error code will be displayed on the outdoor PCB. If the current becomes normal, the indoor sends signal to the outdoor, the outdoor will display normally.

Open Circuit/Disconnection Sensor Protection

1.3 Display Function

Unit display functions

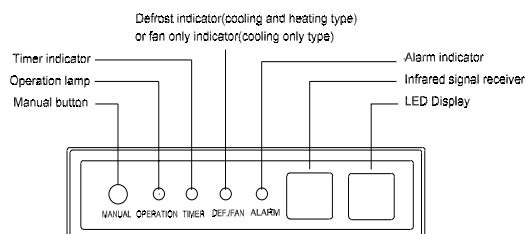

1.4 Fan

When fan mode is activated:

- The outdoor fan and compressor are stopped.
- Temperature control is disabled and no temperature setting is displayed.
- The indoor fan speed can be set to high, medium, low, or auto.
- The louver operations are identical to those in cooling mode.

1.5 Cooling Mode

1.5.1 Compressor Control

- When T1-Ts-ΔT is lower than setting value, the compressor ceases operation.
- When T1-Ts-ΔT is higher than setting value, the compressor continues operation.

1.5.2 Indoor Fan Control

- In cooling mode, the indoor fan operates continuously. The fan speed can be set to high, medium, low or auto..
- The auto fan acts according to the value of T1-TS+ΔT1.

1.5.3 Outdoor Fan Control

- For single-fan outdoor units, the outdoor fan will run following the compressor except when AC is in evaporator high temperature protection in heating mode ,condenser high temperature protection in cooling mode, defrosting mode and the current protection.
- For double-fan units, the outdoor fans will run according to T3.

1.5.4 Evaporator Temperature Protection

When evaporator temperature drops below a configured value for some time, the compressor ceases operations.

1.5.5 Condenser Temperature Protection

When condenser temperature is more than setting value, the compressor ceases operations.

1.6 Heating Mode(Heat pump models)

1.6.1 Compressor Control

- Once the compressor starts up, it keeps running 7 minutes, then it will follow the below rules:
 - When T1-Ts is higher than setting value, the compressor and outdoor fan cease operations. When T1-Ts is lower than setting value, the compressor and outdoor fan restart up.

1.6.2 Indoor Fan Control:

- When the compressor is on, the fan speed can be set to high, medium, low, or auto..And the anti-cold wind function has the priority.
- The auto fan acts according to the value of T1-TS+ ΔT 2.

1.6.3 Outdoor Fan Control:

- For single-fan outdoor units, the outdoor fan will run following the compressor except when AC is in evaporator high temperature protection in heating mode ,condenser high temperature protection in cooling mode, defrosting mode and the current protection.
- For double-fan units, the outdoor fans will run according to T4.

1.6.4 Defrosting mode

- The unit enters defrosting mode according to changes in the temperature value of T3, the temperature value of T4 as well as the compressor running time.
- If any one of the following conditions is satisfied, defrosting ends and the machine switches to normal heating mode:
 - T3 rises above TE18°C.
 - The unit runs for 10 minutes consecutively in defrosting mode.
 - Operation mode is changed to other modes

1.6.5 Evaporator Temperature Protection

When the evaporator temperature exceeds a preset protection value, the compressor and outdoor fan cease operations.

1.7 Auto Mode

- This mode can be selected with the remote controller and the temperature setting can be adjusted between 17°C~30°C

- In auto mode, the machine selects cooling, heating, or fan-only mode on the basis of ΔT ($\Delta T = T1 - T_s$).

ΔT	Running mode
$\Delta T > 2^\circ\text{C}$	Cooling
$-1^\circ\text{C} \leq \Delta T \leq 2^\circ\text{C}$	Fan-only
$\Delta T < -1^\circ\text{C}$	Heating*

Heating*: In auto mode, cooling only models run the fan.

- Indoor fans run at the auto fan speed of the relevant mode.
- The louver operates the same as in relevant mode.
- If the machine switches mode between heating and cooling, the compressor pauses for a certain period of time intermittently and then selects a mode based on T1-Ts.
- If the setting temperature is modified, the machine selects a new running function.

1.8 Drying Mode

- Indoor fan speed is fixed at low and cannot be changed.
- All protections are activated and operate the same as they do in cooling mode.

1.9 Timer Function

- The timing range is 24 hours.
- Timer On. The machine turns on automatically at the preset time.
- Timer Off. The machine turns off automatically at the preset time.
- Timer On/Off. The machine turns on automatically at the preset On Time, and then turns off automatically at the preset Off Time.
- Timer Off/On. The machine turns on automatically at the preset Off Time and then turns off automatically at the preset On Time.
- The timer does not change the unit operation mode. If the unit is off now, it does not start up immediately after the "timer off" function is set. When the setting time is reached, the timer LED switches ioff and the unit running mode remains unchanged.
- The timer uses relative time, not clock time

1.10 Sleep Function

- The sleep function is available in cooling, heating, or auto mode.
- The operational process for sleep mode is as follows:

- When cooling, the temperature rises 1 °C (to not higher than 30 °C) every hour. After 2 hours, the temperature stops rising and the indoor fan is fixed to auto speed.
- When heating, the temperature decreases 1 °C (to not lower than 17 °C) every hour. After 2 hours, the temperature stops decreasing and the indoor fan is fixed at auto speed. Anti-cold wind function takes priority.
- The operating time for sleep mode is 7 hours, after which, the unit exits this mode and switches off.
- The timer setting is available in this mode.

the water level falls and LED alarm code is no longer displayed (drain pump close delay is 1 minute), the unit goes back into its last mode. Otherwise, the entire system (including the pump) stops and the LED displays an alarm again after 3 minutes.

1.11 Auto-Restart

- The indoor unit has an auto-restart module that allows the unit to restart automatically. The module automatically stores the current settings (not including sleep mode) and, in the case of a sudden power failure, will restore those setting automatically within 3 minutes after power returns.
- If the unit was in forced cooling mode, it will run in this mode for 30 minutes and turn to auto mode with temperature set to 24 °C .
- If there is a power failure while the unit is running, the compressor starts 3 minutes after the unit restarts. If the unit was already off before the power failure, the compressor starts 1 minute after the unit restarts.

1.12 Follow Me

- If you press "Follow Me" on the remote, the indoor unit will beep. This indicates the follow me function is active.
- Once active, the remote control will send a signal every 3 minutes, with no beeps. The unit automatically sets the temperature according to the measurements from the remote control.
- The unit will only change modes if the information from the remote control makes it necessary, not from the unit's temperature setting.

1.13 Drain Pump Control (Optional)

- Use the water-level switch to control drain pump.
- The system checks the water level every 5 seconds.
 - When the A/C operates in cooling (including auto cooling) or forced cooling mode, the pump begins running immediately and continuously until cooling stops.
 - If the water level increases up to the control point, the LED displays an alarm code and the drain pump opens and continually monitors the water level. If

2. Remote Controller Functions

2.1 LCD Wired Remote Controller

2.1.1 LCD Wired Remote Controller KJR-12B/DP(T) (Standard)

The KJR-12B/DP(T) wired remote controller is standard for Duct type.

i) Buttons and Functions

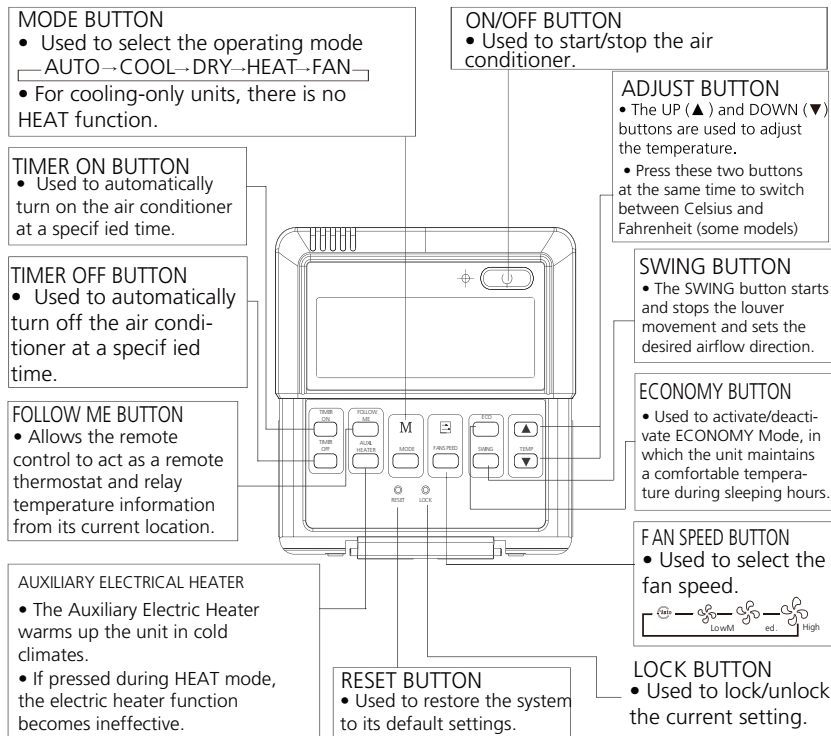

ii) LCD Screen

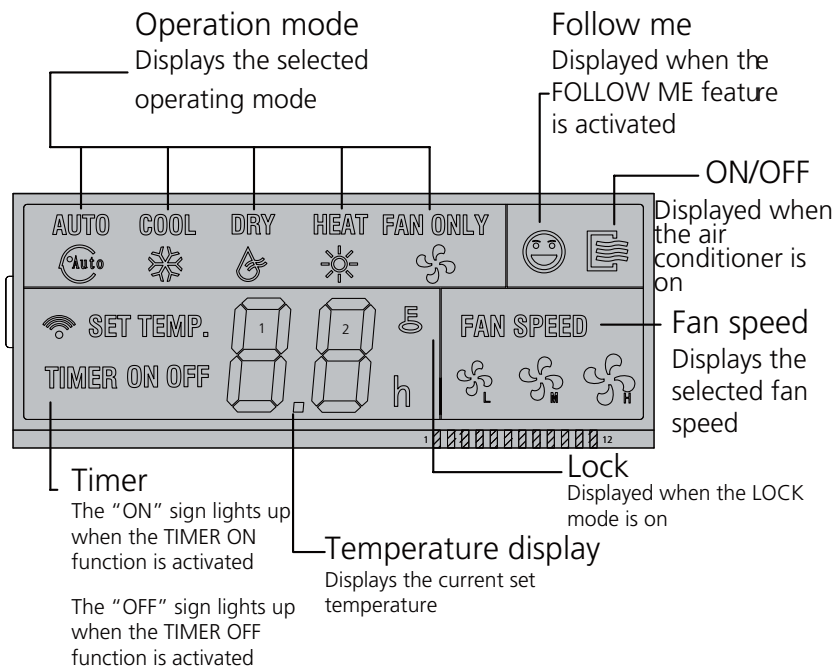

iii) Installation

- Dimensions

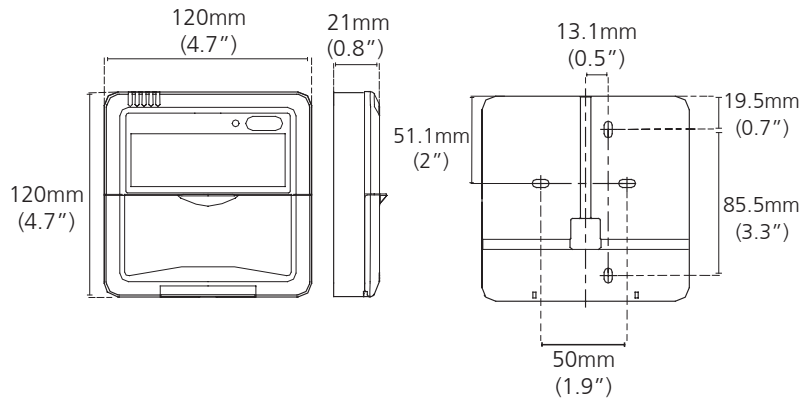

- Wiring diagram

Refer to the following diagram to wire the wall-mounted remote control to the indoor unit.

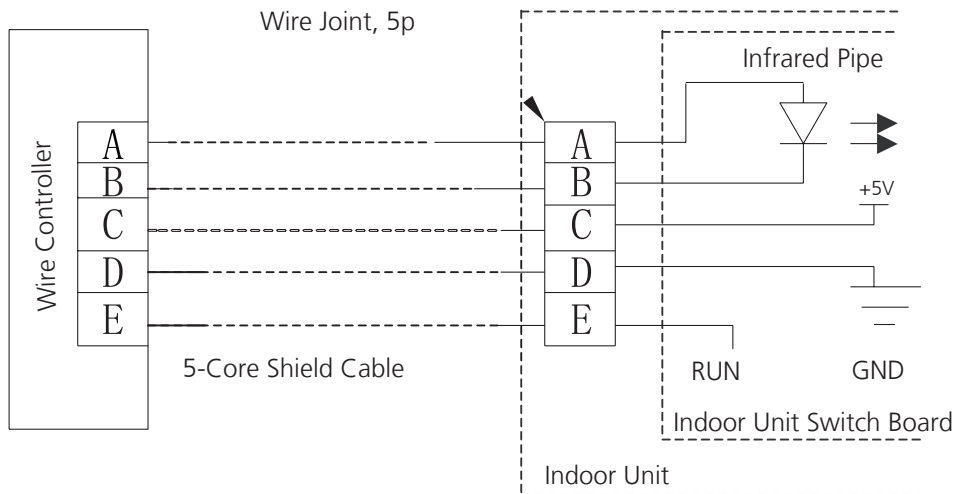

- Installation Diagram

Connect the wire from the display panel of the indoor unit to a connecting cable. Then connect the other side of the connecting cable to the remote control.

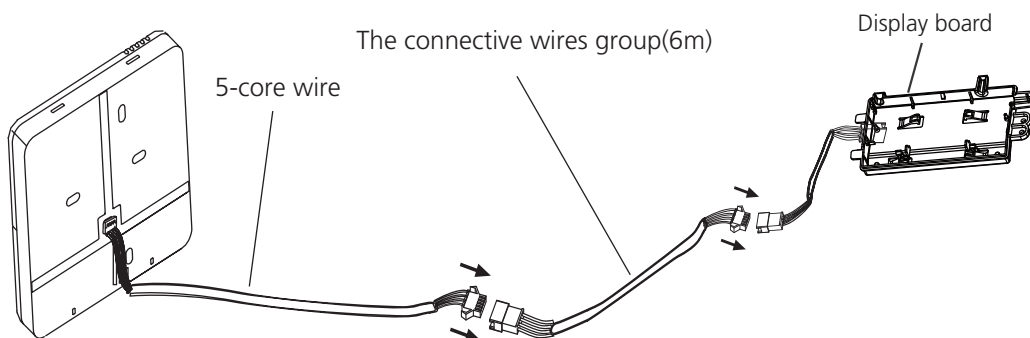

Note: Be sure to reserve a length of the connecting wire for periodic maintenance.

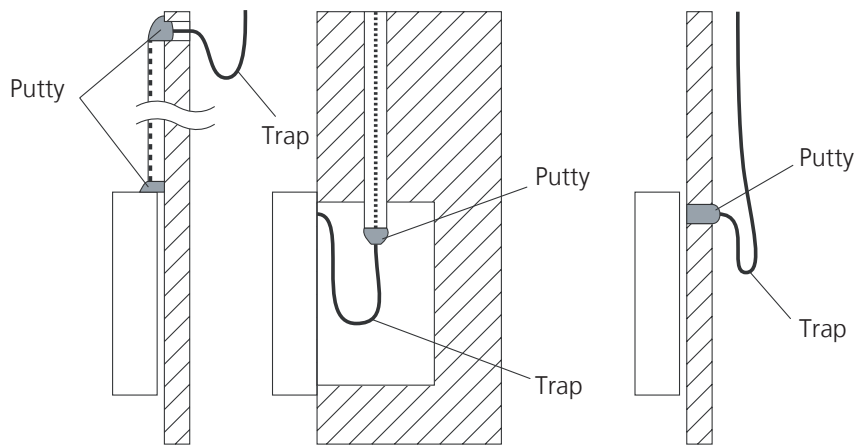

Note: DO NOT allow water to enter the remote control. Use the trap and putty to seal the wires.

- For exposed mounting, cut holes on four of the sides according to the picture below.

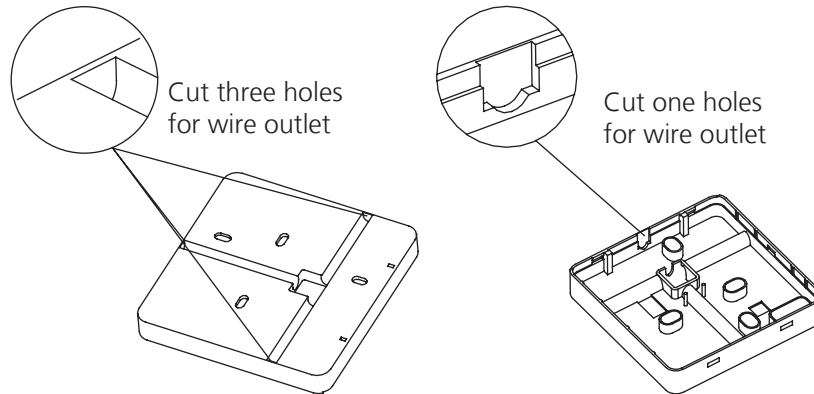

- For shielded wiring, please refer to the picture below.

Embedded switch box wiring

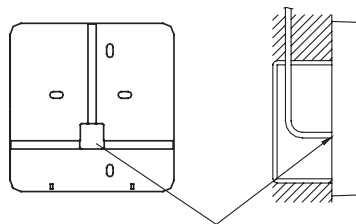

Wiring hole

Wiring through the wall

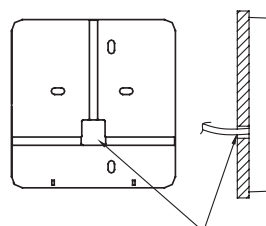

Wall hole and wiring hole
Diameter of wall hole: Φ 2cm

2.1.2 LCD Wired Remote Controller KJR-120C/TF-E(Optional)

The KJR-120C/TF-E wired remote controller is optional for all types.

i) Buttons and Functions

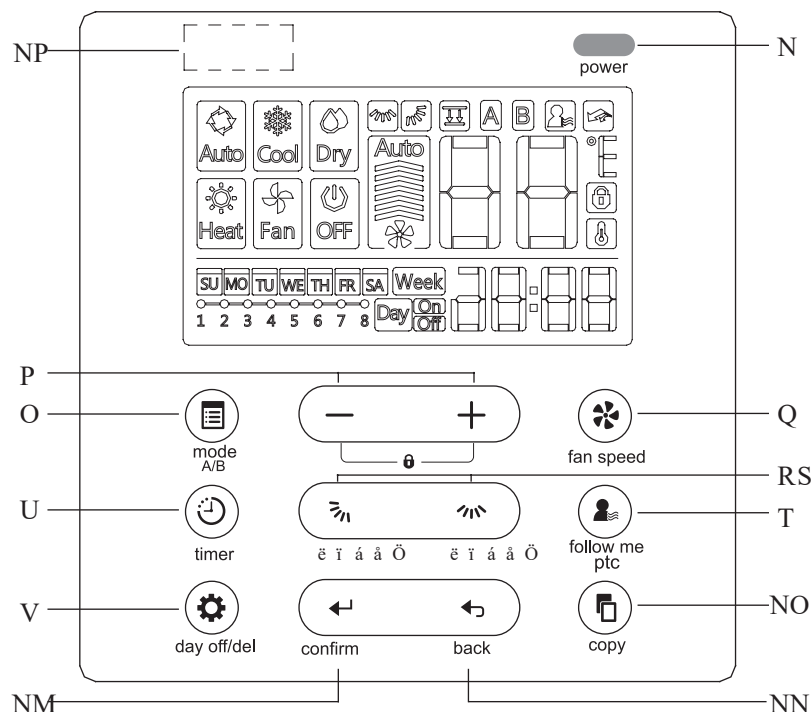

1. POWER button

Turn on or turn off the unit.

2. MODE(A/B) button

Used to select the operation mode: Auto / Cooling / Drying / Heating / Fan;

Hold to activate the operation of auto-lifting panel when off

3. Adjust button

To set temperature, time and timer; set up or down the auto-lifting panel

4. FAN SPEED button

Used to select the fan speed.

5. Up-down airflow direction and swing Button

Press for adjusting the angel of louver, hold for vertical swing; individual louver control for cassette panel

6. Left-right airflow swing Button

Press for activating the horizontal swing

7. FOLLOW ME(PTC) button

Allows the remote control to act as a remote thermostat and send temperature information from its current location.

8. TIMER button

To set timer on and timer off time of one day

9. DELAY/DAY OFF button

To set 1 to 2 hours delay off for each day or a whole day off in a weekly timer schedule

10. CONFIRM button

To confirm an setting or call up the menu

11. BACK button

Back to previous operation or superior menu

12. COPY button

Copy timer setting of one day to another in weekly schedule setting

13 Infrared remote receiver (on some models)

ii) LCD Screen

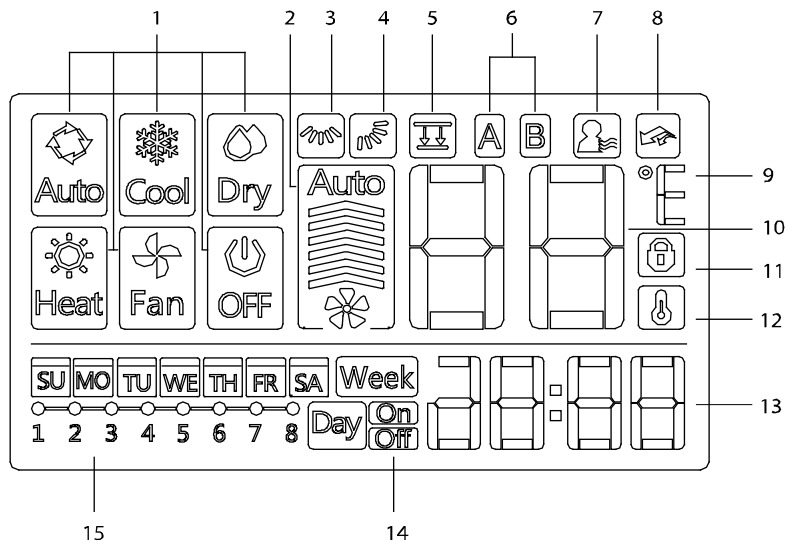

1 Operation mode indication

2 Fan speed indication

3 Left-right swing indication

4 Up-down swing indication

5 Faceplate function indication

6 Main unit and secondary unit indication

7 Follow me function indication

8 PTC function indication

9 C° / F° indication

10 Temperature display

11 Lock indication

12 Room temperature indication

13 Clock display

14 On/Off timer

15 Timer display

iii) Installation

- Dimensions

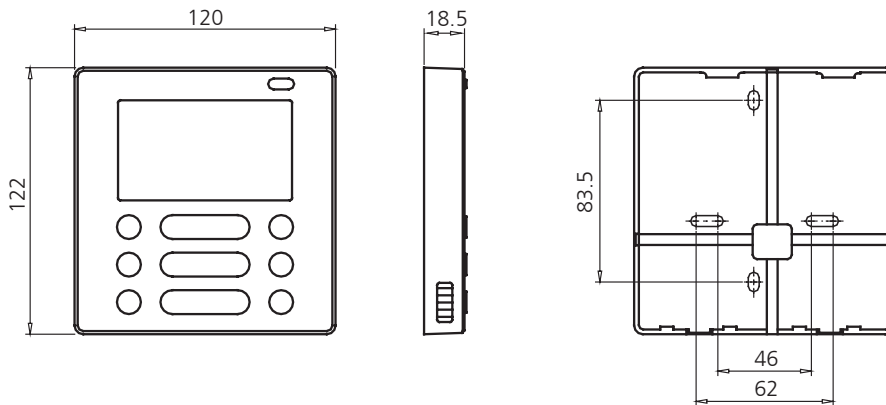

- Wiring diagram

Refer to the following diagram to wire the wall-mounted remote control to the indoor unit.

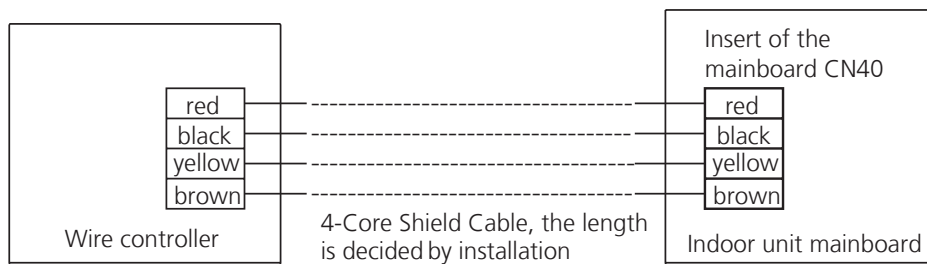

- Installation Diagram

Connect the female joint of wires group from the mainboard with the male joint of connective wires group. Then connect the other side of connective wires group with the male joint of wires group leads from wire controller.

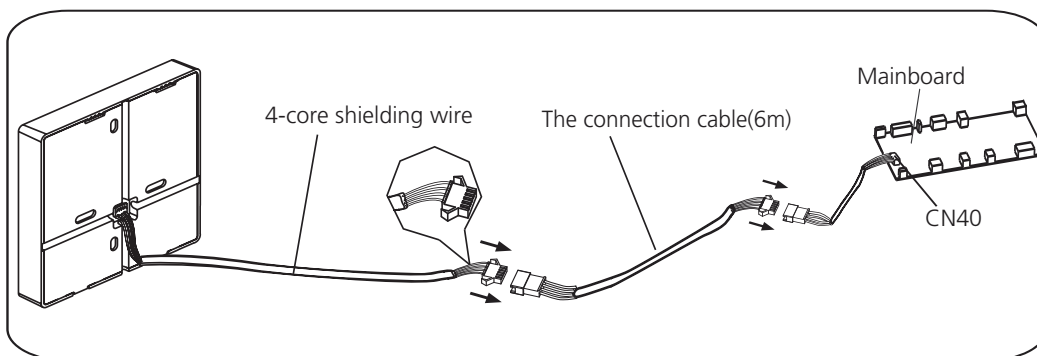

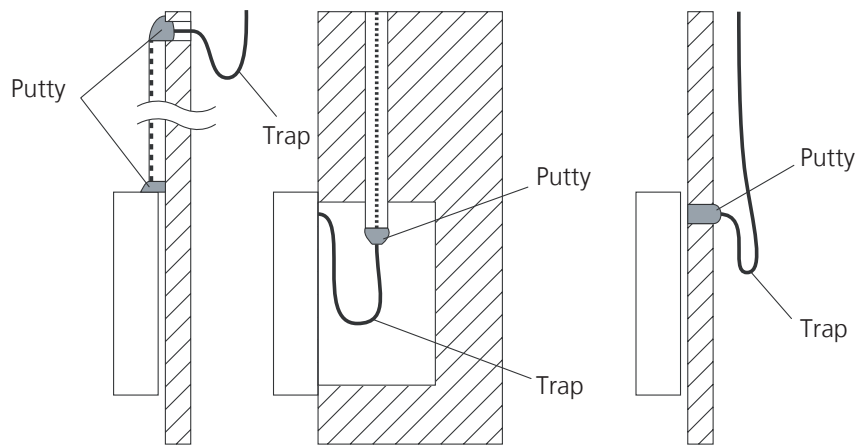

Note: DO NOT allow water to enter the remote control. Use the trap and putty to seal the wires.

- For exposed mounting, four outletting positions. There are three need cutting.

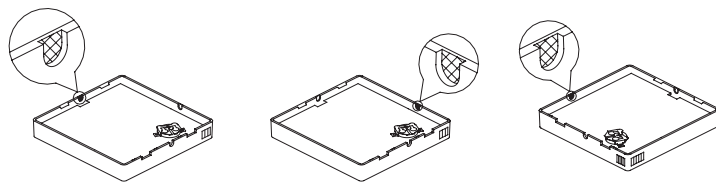

Cutting place of top side wire outlet

Cutting place of left side wire outlet

Cutting place of right side wire outlet

- For shielded wiring, please refer to the picture below.

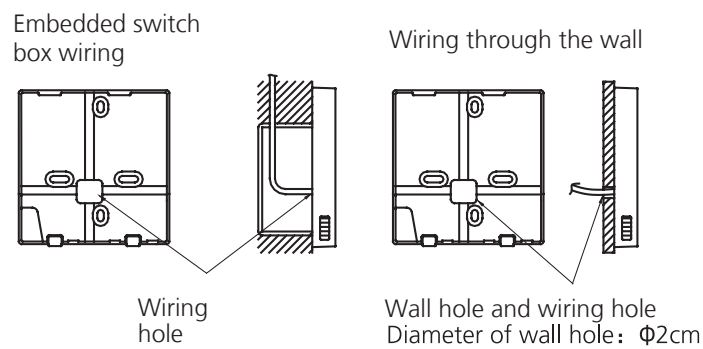

Embedded switch box wiring

Wiring through the wall

Wiring hole

Wall hole and wiring hole
Diameter of wall hole: $\Phi 2\text{cm}$

2.1.3 LCD Wired Remote Controller KJR-120G/TF-E(Optional)

The KJR-120G/TF-E wired remote controller is optional for all types.

i) Buttons and Functions

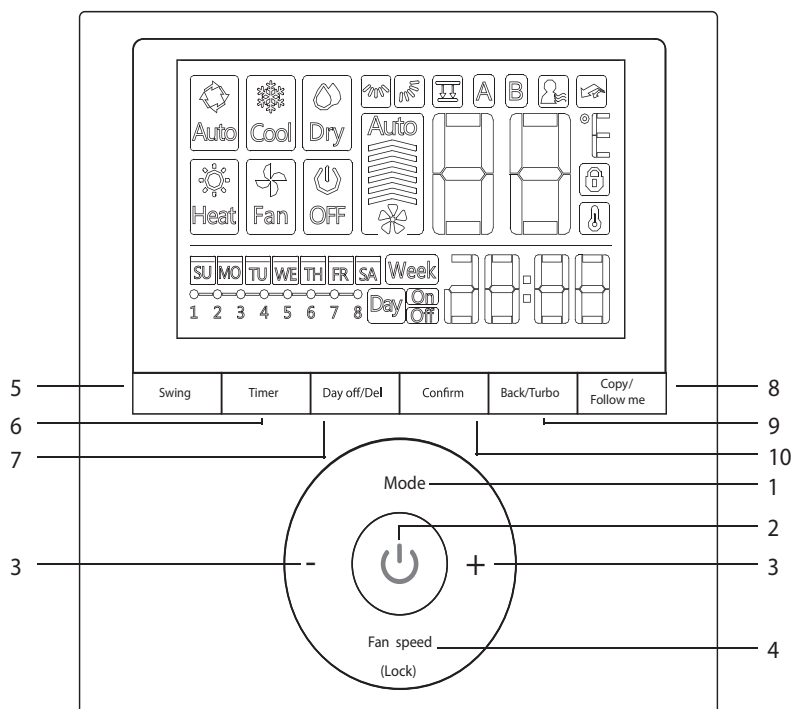

1. MODE button

Used to select the operation mode: Auto / Cooling / Drying / Heating / Fan;

Hold to activate the operation of auto-lifting panel when off

2. POWER button

Turn on or turn off the unit.

3. Adjust button

To set temperature, time and timer; set up or down the auto-lifting panel

4. FAN SPEED button

Used to select the fan speed.

5. Swing Button

Press to active vertical swing, hold for horizontal swing

6. TIMER button

To set timer on and timer off time of one day

7. DELAY/DAY OFF button

To set 1 to 2 hours delay off for each day or a whole day off in a weekly timer schedule

8. COPY/FOLLOW ME button

To copy timer setting of one day to another in weekly schedule setting;

To active the follow me function while in normal operation.

9. BACK/TURBO button

Back to previous operation or superior menu

To active turbo mode while in normal operation

10. CONFIRM button

To confirm an setting or call up the superior menu

ii) LCD Screen

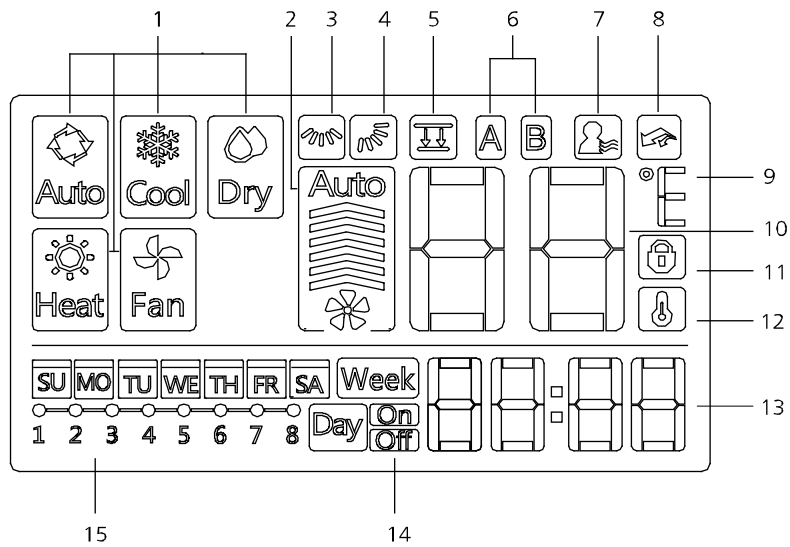

1 Operation mode indication

2 Fan speed indication

3 Left-right swing indication

4 Up-down swing indication

5 Faceplate function indication

6 Main unit and secondary unit indication

7 Follow me function indication

8 Turbo/PTC function indication

9 C° / F° indication

10 Temperature display

11 Lock indication

12 Room temperature indication

13 Clock display

14 On/Off timer

15 Timer display

iii) Installation

- Dimensions

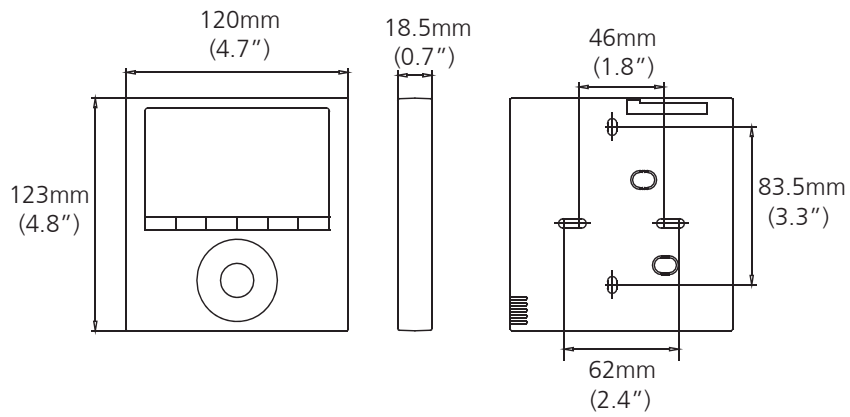

- Wiring diagram

- 1) Connection

For Cassette: The wired controller connects to main control board directly.

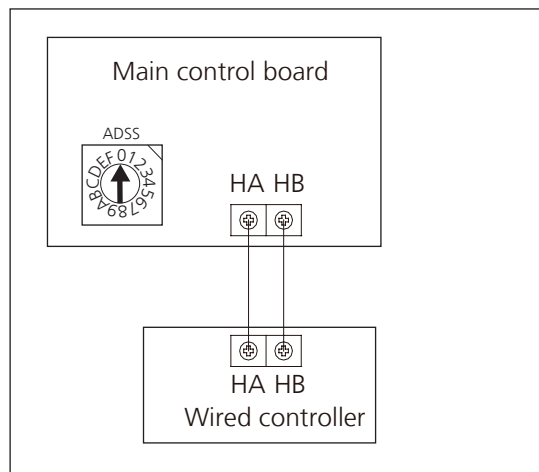

For Duct, Ceiling & floor: The wired controller connects to terminal board, terminal board connects to main control board.

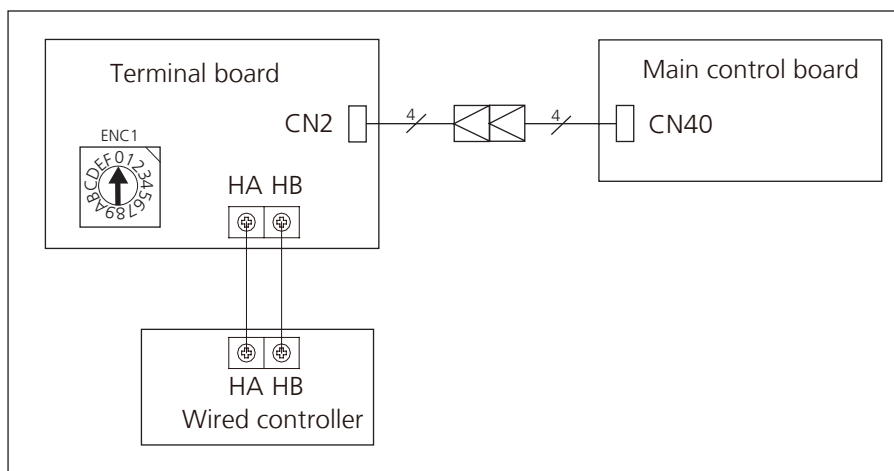

2) Address setting

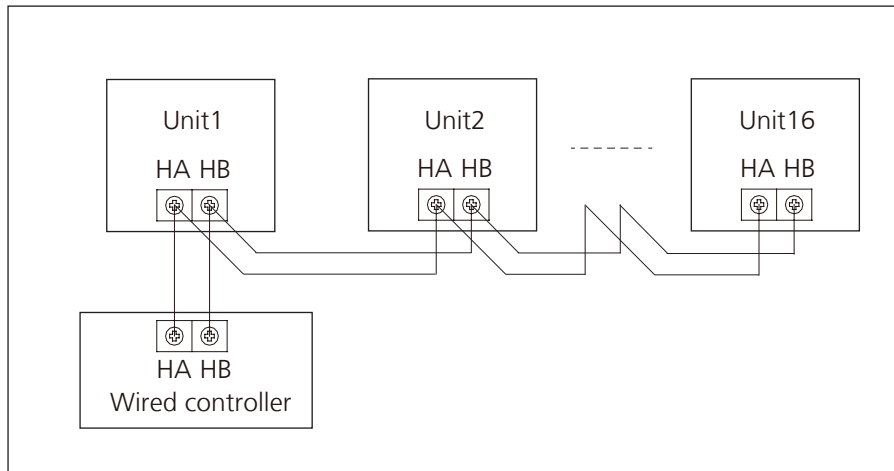

- One non-polarity controller can control up to 16 indoor units.
- When the non-polarity controller is connected to several units, every air-conditioner in network has only one network address to distinguish each other.
- Address code of air-conditioner in LAN is set by code switch ENC1(Duct and Ceiling& Floor) or ADSS(Cassette) of the indoor unit, and the set range is 0-15.
- Note: The indoor units are controlled at the same time, not independently. The purpose of setting network address is identify the unit when error occurs.

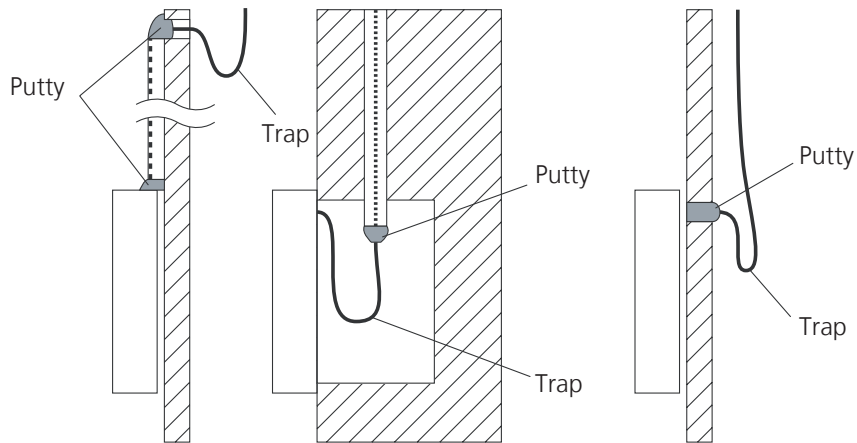

Note: DO NOT allow water to enter the remote control. Use the trap and putty to seal the wires.

• **For wiring the indoor unit, there are three methods:**

- From the rear;
- From the bottom;
- From the top;
- From the top center.

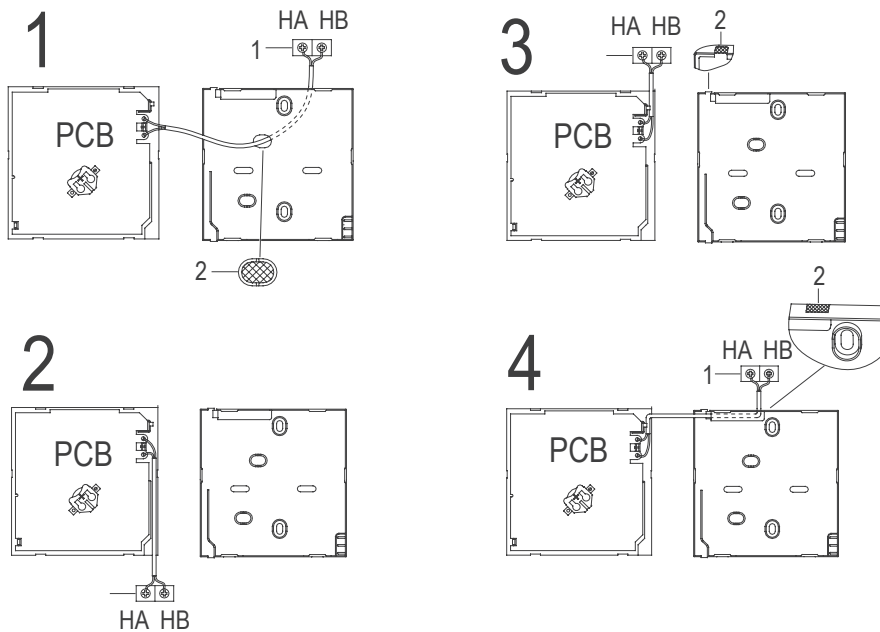

- 1: Indoor Unit.
- 2: Notch the part for the wiring to pass through with a nipper tool.
- Connect the terminals on the remote controller (HA ,HB), and the terminals of the indoor unit. (HA ,HB). (HA and HB do not have polarity.)

2.2 Centralized Controller

1) Connection

For Light commercial air conditioner with XYE port, it can be directly connected to Centralized Controller (CCM03, CCM09).

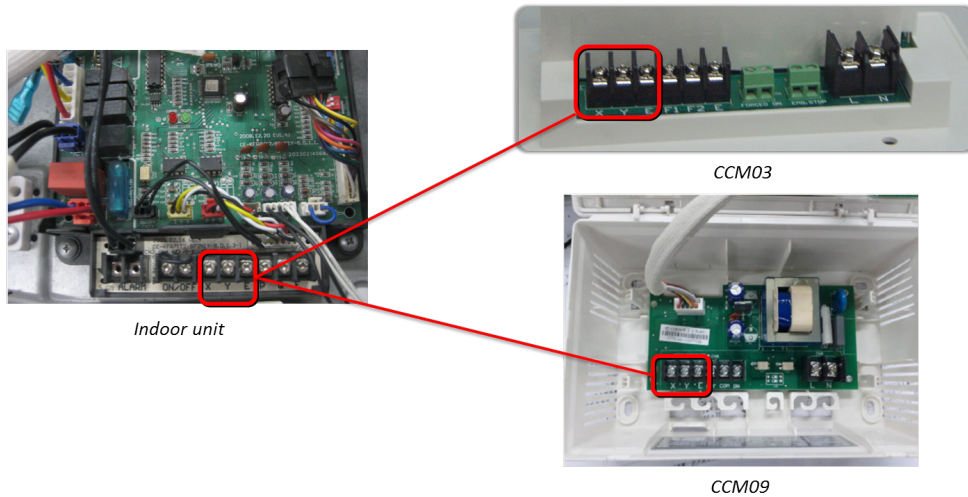

2) Address setting

When setting the address, please make sure the unit is powered off. The address can be set from 0 to 63 by the switch. Turn on the unit, then the address will be effective.

SWITCH		FOR CCM UNIT ADDRESS	
S2 + S1			
ADDRESS	0~15		16~31
Factory Setting	✓		
S2 + S1			
ADDRESS	32~47		48~63
Factory Setting			







Note: For light commercial air conditioner with XYE port, it can be also connected to BMS (Building Management System).

If there is any CAC (central air conditioner) connecting with the central controller at the same time, please set the address from largest (63,62,61...), since the CAC units could obtain address automatically from the smallest (00,01,02...)

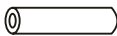
Installation

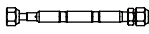
Accessories	76
1. Installation Overview	77
2. Location Selection	78
3. Indoor Unit Installation	79
4. Outdoor Unit Installation.....	82
5. Drainage Pipe Installation.....	83
6. Refrigerant Pipe Installation	86
7. Vacuum Drying and Leakage Checking.....	87
8. Additional Refrigerant Charge	88
9. Engineering of Insulation	88
10. Engineering of Electrical Wiring	89
11. Test Operation	90

Accessories

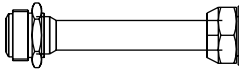
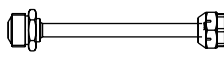
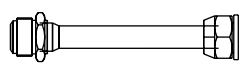
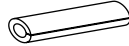
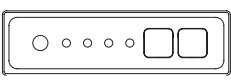
	Name	Shape	Quantity
Tubing & Fittings	Soundproof / insulation sheath		2
	Seal sponge (some models)		1
	Orifice (some models)		1
Drainpipe Fittings (for cooling & heating)	Drain joint (some models)		1
	Seal ring (some models)		1
EMC Magnetic Ring (some models)	Magnetic ring(Wrap the electric wires S1 & S2 (P & Q & E) around the magnetic ring twice)	 S1&S2(P&Q&E)	1
	Magnetic ring(Hitch on the connective cable between the indoor unit and outdoor unit after installation.)		1
Others	Owner's manual	-	1
	Installation manual	-	1
	Transfer connector($\phi 12.7$ - $\phi 15.9$)/($\phi 0.5$ in- $\phi 0.63$ in)(Packed with the indoor unit) NOTE: Pipe size may differ from appliance to appliance. To meet different pipe size requirements, sometimes the pipe connections need a transfer connector installed on the outdoor unit.		1 (on some models)
	Transfer connector($\phi 6.35$ - $\phi 9.52$)/($\phi 0.25$ in- $\phi 0.375$ in)(Packed with the indoor unit) NOTE: Pipe size may differ from appliance to appliance. To meet different pipe size requirements, sometimes the pipe connections need a transfer connector installed on the outdoor unit.		1 (on some models)
	Transfer connector($\phi 9.52$ - $\phi 12.7$)/($\phi 0.375$ in- $\phi 0.5$ in)(Packed with the indoor unit) NOTE: Pipe size may differ from appliance to appliance. To meet different pipe size requirements, sometimes the pipe connections need a transfer connector installed on the outdoor unit.		1 (on some models)
	Connecting wire for display (2m)	-	1(on some models)
	Cord protection rubber ring		1(on some models)
	Display panel *Just for testing purposes only		1(on some models- KJR-120G,KJR-120H)

Optional accessories:

- There are two types of remote controls: wired and wireless.
- Select a remote controller based on customer preferences and requirements and install in an appropriate place.
- Refer to catalogues and technical literature for guidance on selecting a suitable remote controller.

1. Installation Overview

Installation Order

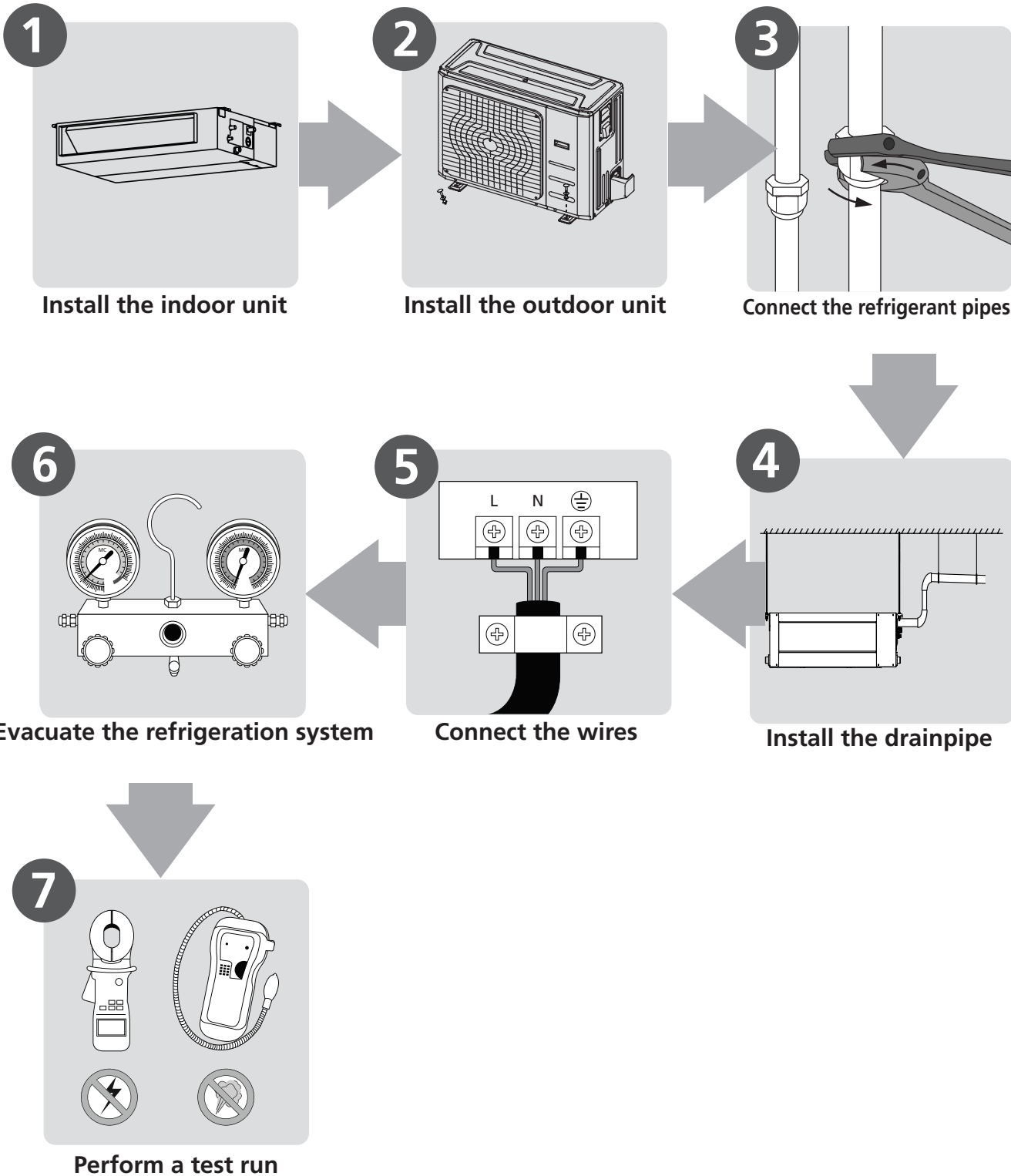

Installation

2. Location selection

2.1 Unit location selection can refer to installation manual.

2.2 **DO NOT** install the unit in the following locations:

- Where oil drilling or fracking is taking place.
- Coastal areas with high salt content in the air.
- Areas with caustic gases in the air, such as near hot springs.
- Areas with power fluctuations, such as factories.
- Enclosed spaces, such as cabinets.
- Areas with strong electromagnetic waves.
- Areas that store flammable materials or gas.
- Rooms with high humidity, such as bathrooms or laundry rooms.
- If possible, **DO NOT** install the unit where it is exposed to direct sunlight.

2.3 **The minimum distance between the outdoor unit and walls described in the installation guide does not apply to airtight rooms. Be sure to keep the unit unobstructed in at least two of the three directions (M, N, P)**

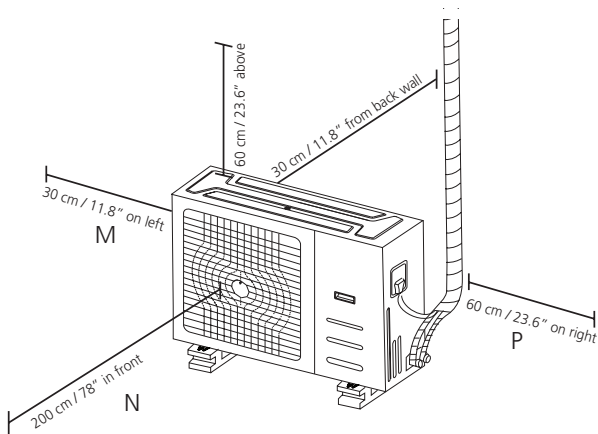

2.4 Rows of series installation

The relations between H, A and L are as follows.

	L	A
L ≤ H	$L \leq 1/2H$	25 cm / 9.8" or more
	$1/2H < L \leq H$	30 cm / 11.8" or more
L > H	Can not be installed	

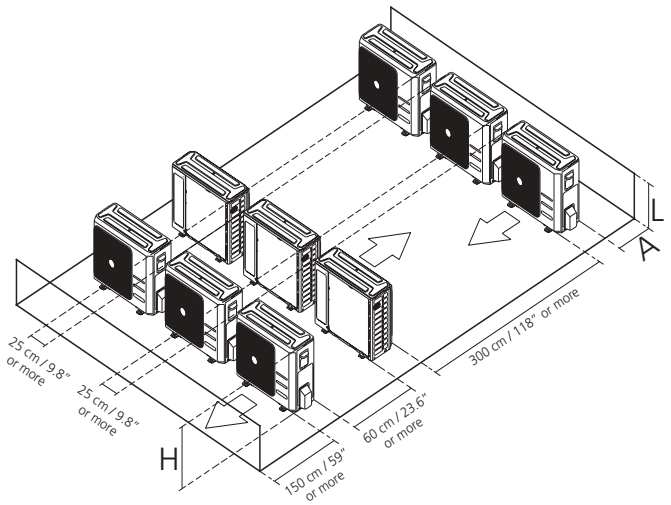

DO NOT install the rows of series like following figure.

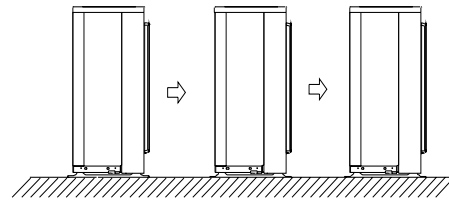

2.5 If the location is exposed to strong winds (for example: near a seaside), the unit must be placed against the wall to shelter it from the wind. If necessary, use an awning.

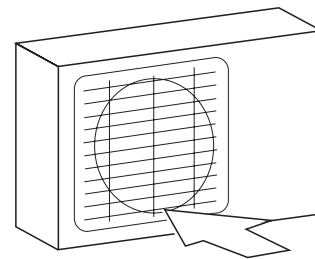

DO NOT Strong wind

3. Indoor Unit Installation

3.1 Service space for indoor unit

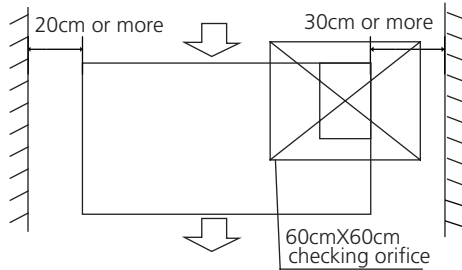

3.2 Hang Indoor Unit

1. Please refer to the following diagrams to locate the four positioning screw bolt hole on the ceiling. Be sure to mark the areas where ceiling hook holes will be drilled.

For A6 Duct,

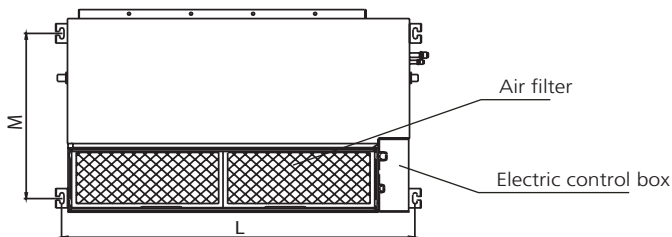

Capacity(KBtu/h)	Size of mounted plug	
	L	M
18	920	508
24~36	1140	598
48~60	1240	697

2. Install and fit pipes and wires after you have finished installing the main body. When choosing where to start, determine the direction of the pipes to be drawn out.

Especially in cases where there is a ceiling involved, align the refrigerant pipes, drain pipes, and indoor and outdoor lines with their connection points before mounting the unit.

3. Install hanging screw bolts.

- 1) Cut off the roof beam.
- 2) Strengthen the point at which the cut was made. Consolidate the roof beam..

4. After you select an installation location, align the refrigerant pipes, drain pipes, as well as indoor and outdoor wires with their connection points before mounting the unit..

5. Drill 4 holes 10cm (4") deep at the ceiling hook

positions in the internal ceiling. Be sure to hold the drill at a 90° angle to the ceiling.

6. Secure the bolt using the included washers and nuts.

7. Install the four suspension bolts.

8. Mount the indoor unit with at least two people to lift and secure it. Insert suspension bolts into the unit's hanging holes. Fasten them using the washers and nuts provided.

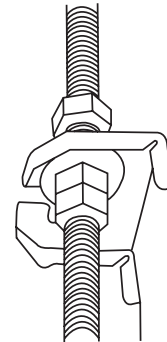

9. Mount the indoor unit onto the hanging screw bolts with a block. Position the indoor unit flat using a level indicator to prevent leaks.

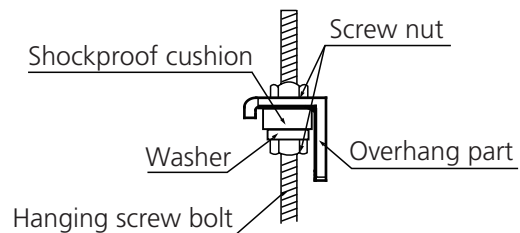

Note: Confirm the minimum drain tilt is 1/100 or more.

3.3 Duct and accessories installation

1. Install the filter(optional) according to air inlet size.
2. Install the canvas tie-in between the body and duct.
3. The air inlet and air outlet duct should be far enough apart enough to a avoid air passage short-circuit.
4. Connect the duct according to the following diagram.

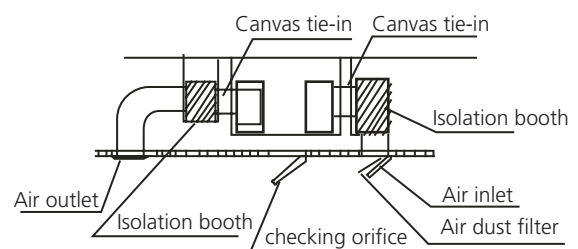

5. Refer to the following static pressure guidelines when installing the indoor unit.

Model(KBtu/h)	Static Pressure(Pa)
18~24	0-80
30~36	0-100
48~60	0-160

Change the fan motor static pressure according to external duct static pressure.

NOTE: 1. Do not put the connecting duct weight on the indoor unit.

2. When connecting the duct, use a nonflammable canvas tie-in to prevent vibrating.

3. When connecting duct, install in place prone to takedown for maintenance.

4. Change the fan motor static pressure corresponding to external duct static pressure.

5. If installed in place like meeting room where noise is easy to be perceived, design isolation booth and internal duct underlayer to muffle the duct system and weaken the air encounter noise in the duct.

Adjust the air inlet direction(From rear side to under-side.)

1. Take off ventilation panel and flange,

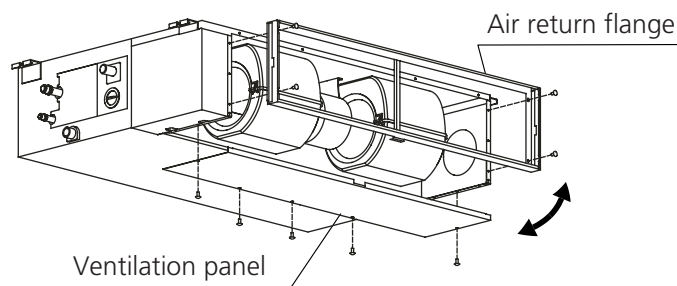

Bend the rear ventilation panel 90 degrees along the dotted line into a descending ventilation panel.(some models)

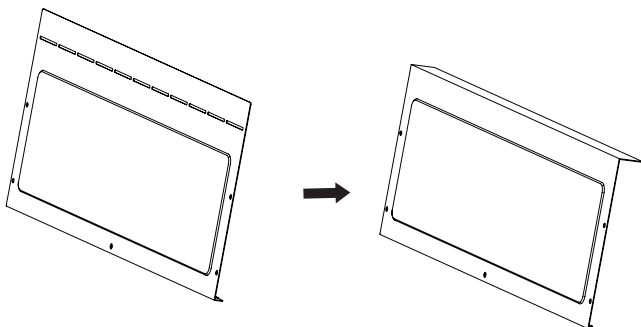

2. Change the mounting positions of ventilation panel and air return flange .

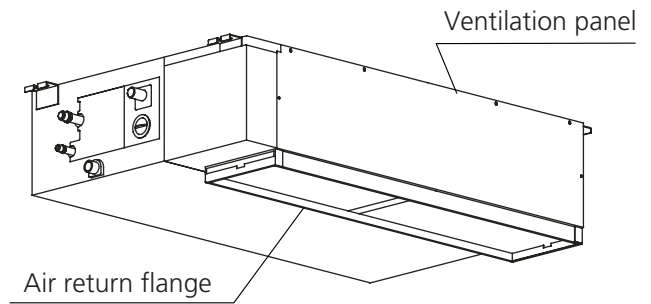

3. When installing the filter mesh, fit it into the flange as illustrated in the following figure.

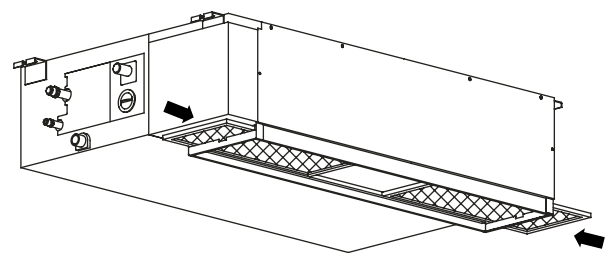

Or

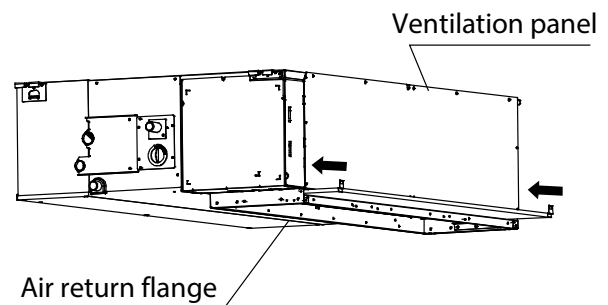

NOTE: All the figures in this manual are for demonstration purposes only. The air conditioner you have purchased may be slightly different in design, though similar in shape.

3.5 Fresh air duct installation Dimension :

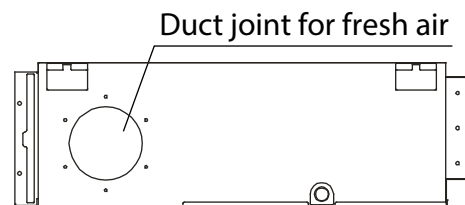

9-12k

Ø92mm(3.62")

Ø113mm(4.45")

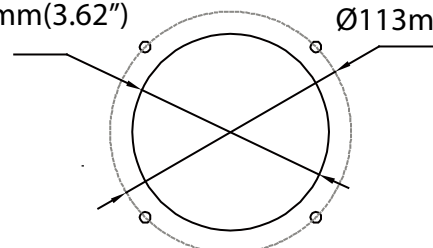

18-60k

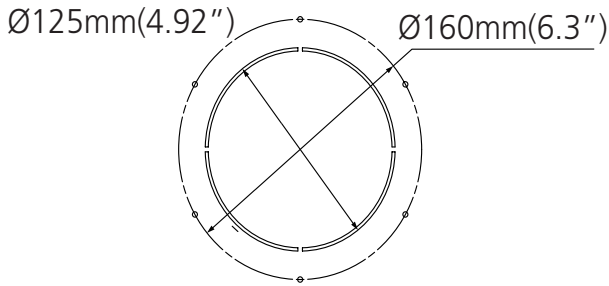

3.6 Horizontal Installation

3.6.1 With External pump (9K, 12K models)

Cut both ends of the rubber hose into a straight one, use it to connect the drain Connector A and the external pump and safety it with clamps on both ends. Then connect the drainpipe to the Connector B.

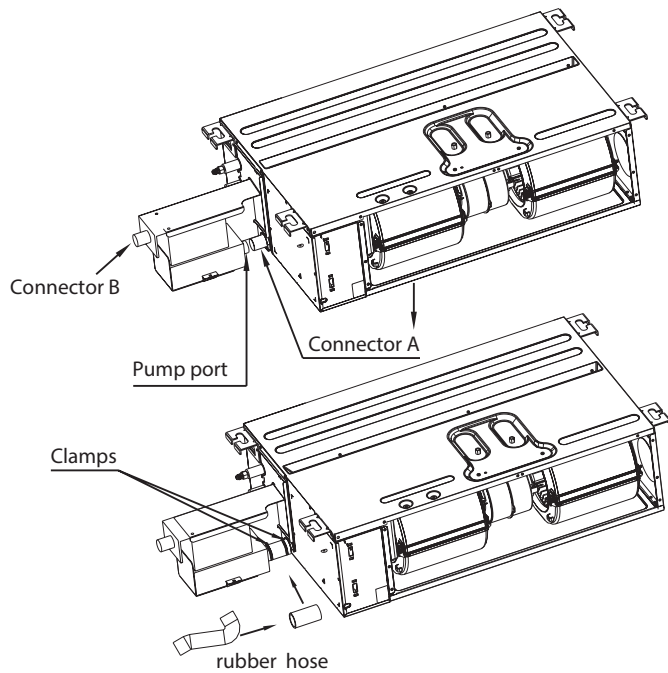

3.6.2 With External pump (18K model only)

Drain connector A, B & C are covered with caps originally. Take the cap on drain connector B off, connect the external pump to drain connector B using a hose & two hoseclamps. Then connect the drainpipe to the connector D.

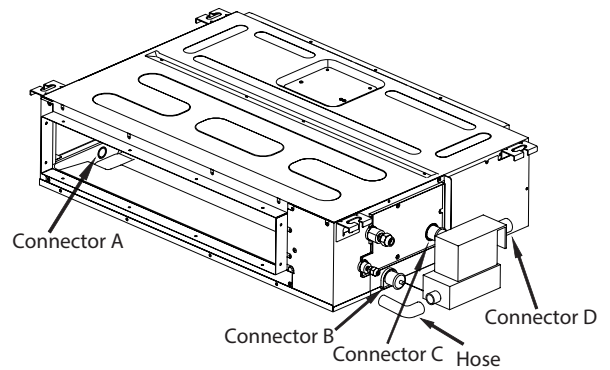

Plug the external pump to the "PUMP" pin and the water level sensor to the "CN5" to enable the pump.

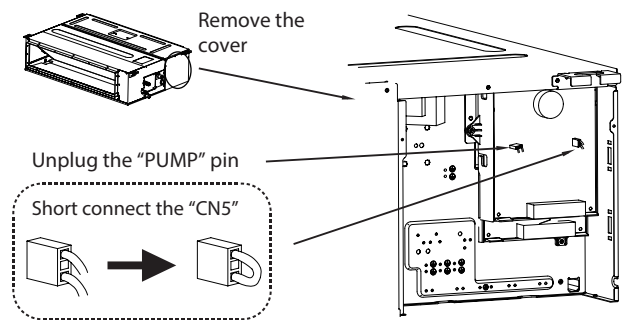
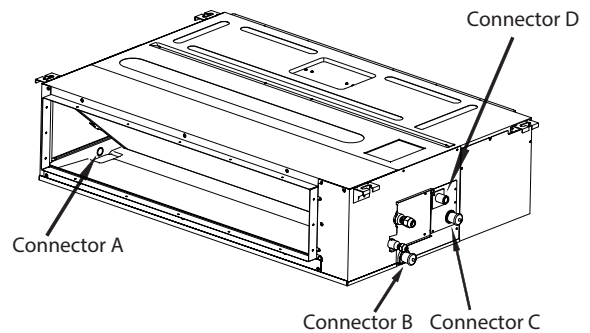

Fig. 1

3.6.3 With Built-in pump (24K, 36K, 48K models)

Drain connector A, B & C are covered with caps originally. Connect the drainpipe to the connector D.



3.7 Vertical Installation

3.7.1 No need pump (Disable pump)

The pump must be disabled while the unit is installed vertically or the pump assembly is removed from its original position.

Open the cover of E-Parts Box assembly, unplug the "PUMP" pin to disable the pump function, and short connect "CN5" plug to disable the water level sensor. (see Fig. 1)

3.7.2 Drain pipe connecting

When installed vertically (up flow), the pump must be disabled firstly. Follow the 3.7.1 steps to disable the pump. For the unit with external pump (9K ,12K &18K models), the whole pump assembly can be removed. Then take the cap on drain connector off and connect the drainpipe to drain connector .

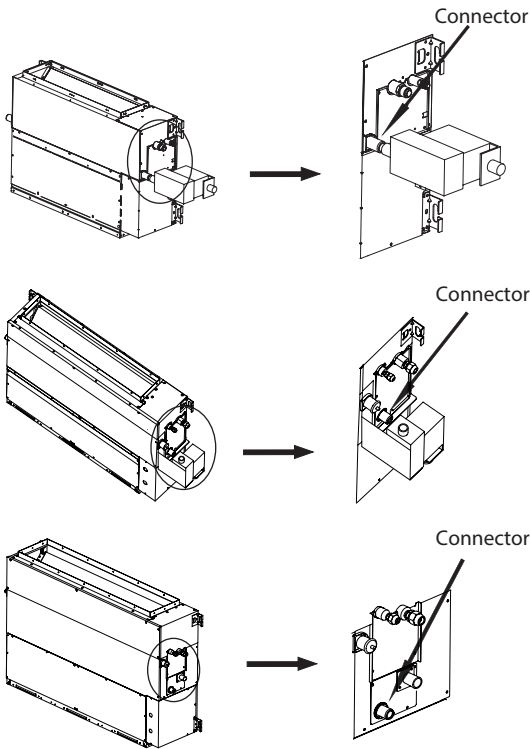

4. Outdoor unit installation(Side Discharge Unit)

4.1 Service space for outdoor unit

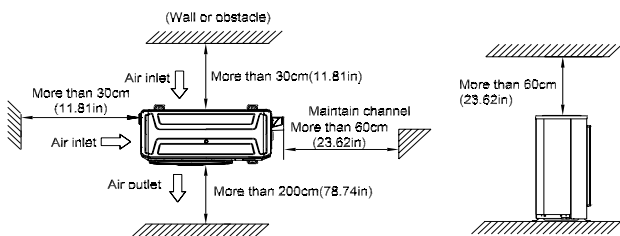

4.2 Bolt pitch

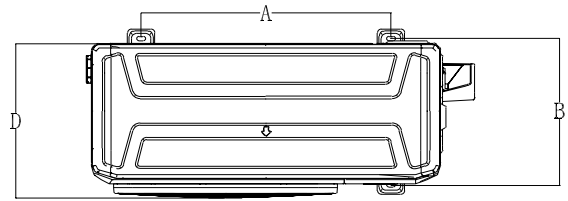

Capacity(kBtu/h)	A	B	D
18	487	298	300
24	540	350	363
36	673	403	410
48/60	590	378	350

4.3 Install Outdoor Unit

Fix the outdoor unit with anchor bolts(M10)

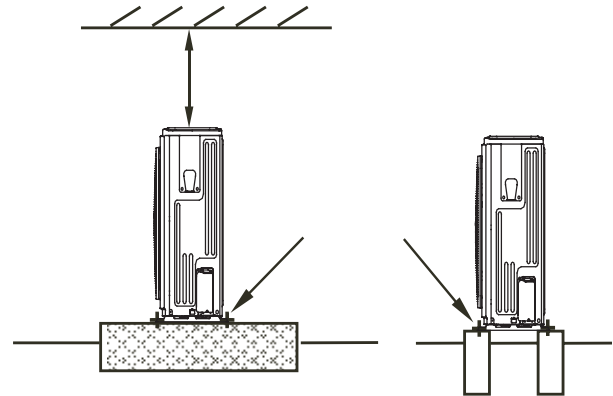

Cation

Since the gravity center of the unit is not at its physical center, so please be careful when lifting it with a sling.

Never hold the inlet of the outdoor unit to prevent it from deforming.

Do not touch the fan with hands or other objects.

Do not lean it more than 45, and do not lay it sidelong.

Make concrete foundation according to the specifications of the outdoor units.

Fasten the feet of this unit with bolts firmly to prevent it from collapsing in case of earthquake or strong wind.

5. Drainage Pipe Installation

Install the drainage pipe as shown below and take measures against condensation. Improperly installation could lead to leakage and eventually wet furniture and belongings.

5.1 Installation principle

- Ensure at least 1/100 slope of the drainage pipe
- Adopt suitable pipe diameter
- Adopt nearby condensate water discharge

5.2 Key points of drainage water pipe installation

1. Considering the pipeline route and elevation.
 - Before installing condensate water pipeline, determine its route and elevation to avoid intersection with other pipelines and ensure slope is straight.
2. Drainage pipe selection
 - The drainage pipe diameter shall not small than the drain hose of indoor unit
 - According to the water flowrate and drainage pipe slope to choose the suitable pipe, the water flowrate is decided by the capacity of indoor unit.

Relationship between water flowrate and capacity of indoor unit

Capacity (kBtu)	Water flowrate (l/h)
36	8
42	10
48	12
60	14

According to the above table to calculate the total water flowrate for the confluence pipe selection.

For horizontal drainage pipe (The following table is for reference)

PVC pipe	Reference value of inner diameter of pipe (mm)	Allowable maximum water flowrate (l/h)		Remark
		Slope 1/50	Slope 1/100	
PVC25	20	39	27	For branch pipe
PVC32	25	70	50	
PVC40	31	125	88	Could be used for confluence pipe
PVC50	40	247	175	
PVC63	51	473	334	

Attention: Adopt PVC40 or bigger pipe to be the main pipe.

For Vertical drainage pipe (The following table is for reference)

PVC pipe	Reference value of inner diameter of pipe (mm)	Allowable maximum water flowrate (l/h)	Remark
PVC25	20	220	For branch pipe
PVC32	25	410	
PVC40	31	730	Could be used for confluence pipe
PVC50	40	1440	
PVC63	51	2760	
PVC75	67	5710	
PVC90	77	8280	

Attention: Adopt PVC40 or bigger pipe to be the main pipe.

3. Individual design of drainage pipe system
 - The drainage pipe of air conditioner shall be installed separately with other sewage pipe, rainwater pipe and drainage pipe in building.
 - The drainage pipe of the indoor unit with water pump should be apart from the one without water pump.
4. Supporter gap of drainage pipe
 - In general, the supporter gap of the drainage pipe horizontal pipe and vertical pipe is respectively 1m~1.5m and 1.5m~2.0m.
 - Each vertical pipe shall be equipped with not less than two hangers.
 - Overlarge hanger gap for horizontal pipe shall create bending, thus leading to air block.

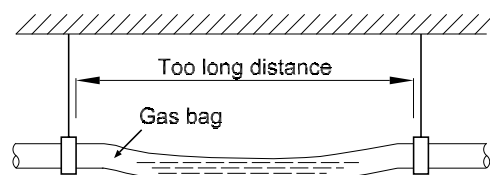

5. The horizontal pipe layout should avoid converse flow or bad flow

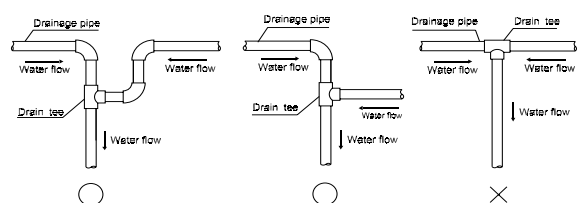

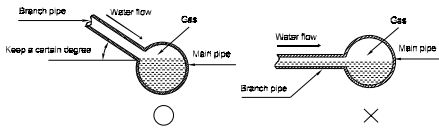

- The correct installation will not cause converse water flow and the slope of the branch pipes can be adjusted freely
- The false installation will cause converse water flow and the slope of the branch pipe can not be adjusted.

6. Water storage pipe setting

- If the indoor unit has high extra static pressure and without water pump to elevate the condensate water, such as high extra static pressure duct unit, the water storage pipe should be set to avoid converse flow or blow water phenomena.

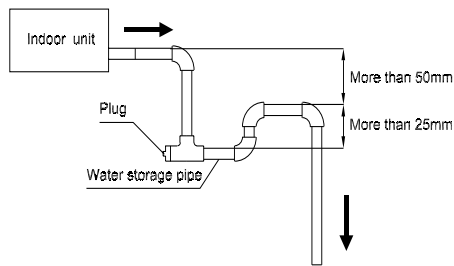

7. Lifting pipe setting of indoor unit with water pump

- The length of lifting pipe should not exceed 750mm.
- The drainage pipe should be set down inclined after the lifting pipe immediately to avoid wrong operation of water level switch.
- Refer the following picture for installation reference.

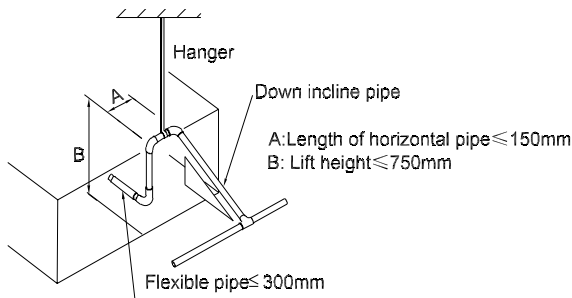

8. Blowhole setting

- For the concentrated drainage pipe system, there should design a blowhole at the highest point of main pipe to ensure the condensate water discharge smoothly.
- The air outlet shall face down to prevent dirt enter-

ing pipe.

- Each indoor unit of the system should be installed it.
- The installation should be considering the convenience for future cleaning.

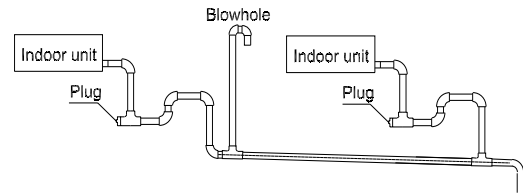

9. The end of drainage pipe shall not contact with ground directly.

5.3 Drainage test

1. Water leakage test

- After finishing the construction of drainage pipe system, fill the pipe with water and keep it for 24 hours to check whether there is leakage at joint section.

2. Water discharge test

Check that the drainpipe is unhindered.

This test should be performed on newly built houses before the ceiling is paved.

2.1 Units without a pump

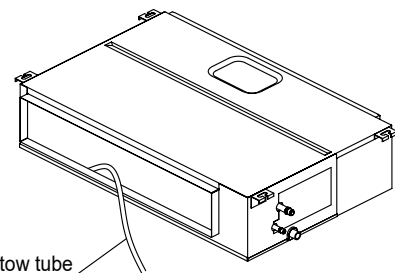

- Fill the water pan with 2 liters of water.
- Check that the drainpipe is unhindered

2.2 Units with a pump

1. Remove the test cover.
- Fill the water pan with 2 liters of water.

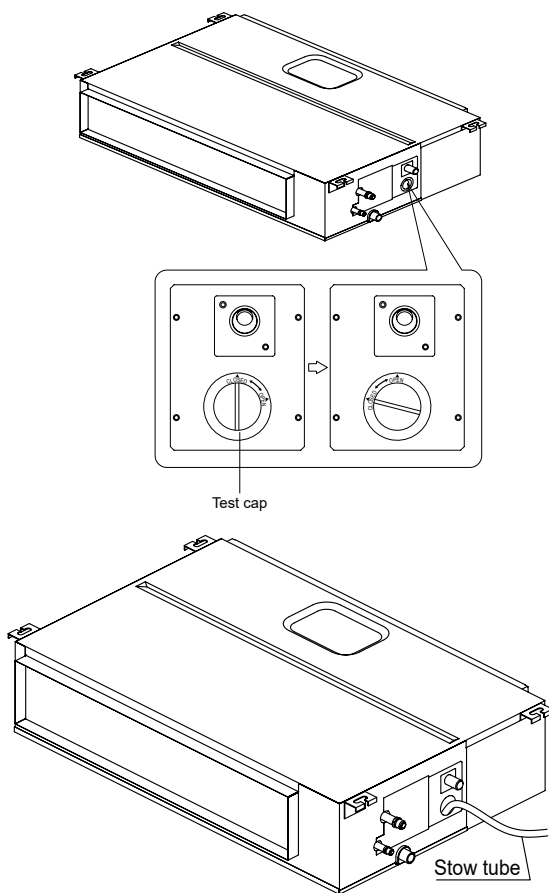

5.4 Insulation work of drainage pipe

Refer the introduction to the insulation engineering parts.

2. Turn on the unit in COOLING mode. You will hear the drain pump. Check whether the water is discharged properly (a 1-minute lag is possible, depending on the length of the drain pipe), Check whether water leaks from the joints.

3. Turn off the air conditioner and put the cap back on.

- After turn off the air conditioner 3 minutes, check whether there is anything abnormal. If drainage pipes have not been distributed properly, over back-flow water shall cause the flashing of alarm indicator at remote-controlled receiving board and even water shall run over the water collector.
- Continuously infusing water until water level alarmed, check whether the drainage pump could discharge water at once. If water level does not decline under warning water level 3 minutes later, it shall cause shutdown of unit. When this situation happens, the normal startup only can be recovered by turning down power supply and eliminating accumulated water.

Note: Drain plug at the main water-containing plate is used for eliminating accumulated water in water-containing plate when maintaining air conditioner fault. During normal operation, the plug shall be filled in to prevent leakage.

6. Refrigerant Pipe Installation

6.1 Maximum length and drop height

Ensure that the length of the refrigerant pipe, the number of bends, and the drop height between the indoor and outdoor units meets the requirements shown in the following table.

Capacity(kBtu/h)	Max. Length (m/ft)	Max. Elevation (m/ft)
18~24	25/82.0	15/49.2
30~36	30/98.4	20/65.6
48~60	50/164	30/98.4

caution:

- The capacity test is based on the standard length and the maximum permissible length is based on the system reliability.
- Oil traps

-If oil flows back into the outdoor unit's compressor, this might cause liquid compression or deterioration of oil return. Oil traps in the rising gas piping can prevent this.

-An oil trap should be installed every 6m(20ft) of vertical suction line riser (<36000Btu/h unit).

-An oil trap should be installed every 10m(32.8ft) of vertical suction line riser (≥36000Btu/h unit).

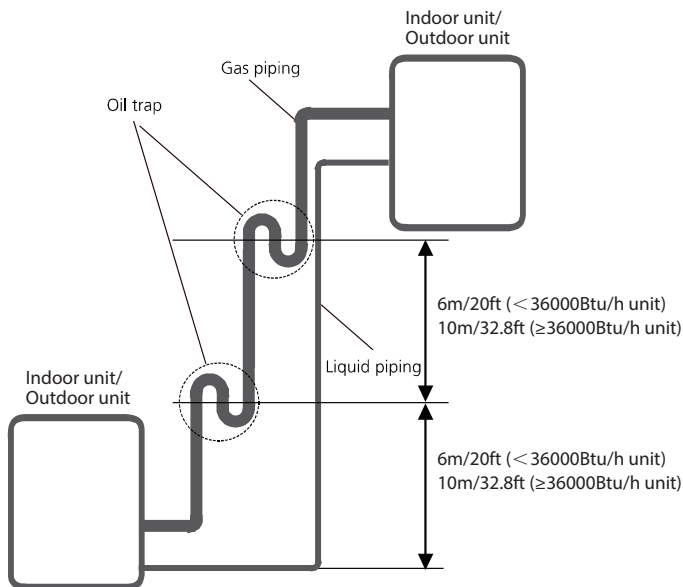

6.2 The procedure of connecting pipes

1. Choose the pipe size according to the specification table.
2. Confirm the cross way of the pipes.

3. Measure the necessary pipe length.

4. Cut the selected pipe with pipe cutter

- Make the section flat and smooth.

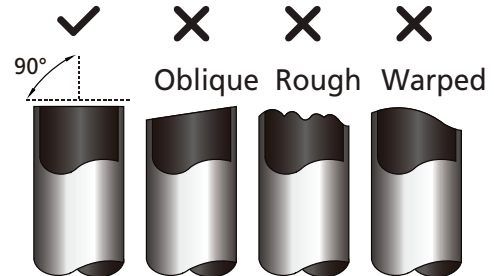

5. Insulate the copper pipe

- Before test operation, the joint parts should not be heat insulated.

6. Flare the pipe

- Insert a flare nut into the pipe before flaring the pipe
- According to the following table to flare the pipe.

Pipe diameter (inch(mm))	Flare dimension A (mm/inch)		Flare shape
	Min	Max	
1/4" (6.35)	8.4/0.33	8.7/0.34	
3/8" (9.52)	13.2/0.52	13.5/0.53	
1/2" (12.7)	16.2/0.64	16.5/0.65	
5/8" (15.9)	19.2/0.76	19.7/0.78	
3/4" (19)	23.2/0.91	23.7/0.93	
7/8" (22)	26.4/1.04	26.9/1.06	

- After flared the pipe, the opening part must be seal by end cover or adhesive tape to avoid duct or exogenous impurity come into the pipe.

7. Drill holes if the pipes need to pass the wall.

8. According to the field condition to bend the pipes so that it can pass the wall smoothly.

9. Bind and wrap the wire together with the insulated pipe if necessary.

10. Set the wall conduit

11. Set the supporter for the pipe.

12. Locate the pipe and fix it by supporter

- For horizontal refrigerant pipe, the distance between supporters should not be exceed 1m.
- For vertical refrigerant pipe, the distance between supporters should not be exceed 1.5m.

13. Connect the pipe to indoor unit and outdoor unit by using two spanners.

- Be sure to use two spanners and proper torque to fasten the nut, too large torque will damage the bellmouthing, and too small torque may cause leakage. Refer the following table for different pipe connection.

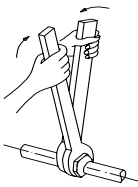
Pipe Diameter	Torque	Sketch map
	N.m(lb.ft)	
1/4" (6.35)	15~16 (11~11.8)	
3/8" (9.52)	25~26 (18.4~19.18)	
1/2" (12.7)	35~36 (25.8~26.55)	
5/8" (15.9)	45~47 (33.19~34.67)	
3/4" (19)	65~67 (47.94~49.42)	
7/8" (22)	75~85 (55.3~62.7)	

7. Vacuum Drying and Leakage Checking

7.1 Purpose of vacuum drying

- Eliminating moisture in system to prevent the phenomena of ice-blockage and copper oxidation. Ice-blockage shall cause abnormal operation of system, while copper oxide shall damage compressor.
- Eliminating the non-condensable gas (air) in system to prevent the components oxidizing, pressure fluctuation and bad heat exchange during the operation of system.

7.2 Selection of vacuum pump

- The ultimate vacuum degree of vacuum pump shall be -756mmHg or above.
- Precision of vacuum pump shall reach 0.02mmHg or above.

7.3 Operation procedure for vacuum drying

Due to different construction environment, two kinds of vacuum drying ways could be chosen, namely ordinary vacuum drying and special vacuum drying.

7.3.1 Ordinary vacuum drying

1. When conduct first vacuum drying, connect pressure gauge to the infusing mouth of gas pipe and liquid pipe,

and keep vacuum pump running for 1 hour (vacuum degree of vacuum pump shall be reached -755mmHg).

2. If the vacuum degree of vacuum pump could not reach -755mmHg after 1 hour of drying, it indicates that there is moisture or leakage in pipeline system and need to go on with drying for half an hour.

3. If the vacuum degree of vacuum pump still could not reach -755mmHg after 1.5 hours of drying, check whether there is leakage source.

4. Leakage test: After the vacuum degree reaches -755mmHg, stop vacuum drying and keep the pressure for 1 hour. If the indicator of vacuum gauge does not go up, it is qualified. If going up, it indicates that there is moisture or leak source.

7.3.2 Special vacuum drying

The special vacuum drying method shall be adopted when:

1. Finding moisture during flushing refrigerant pipe.
2. Conducting construction on rainy day, because rain water might penetrated into pipeline.
3. Construction period is long, and rain water might penetrated into pipeline.
4. Rain water might penetrate into pipeline during construction.

Procedures of special vacuum drying are as follows:

1. Vacuum drying for 1 hour.
2. Vacuum damage, filling nitrogen to reach 0.5Kgf/cm².

Because nitrogen is dry gas, vacuum damage could achieve the effect of vacuum drying, but this method could not achieve drying thoroughly when there is too much moisture. Therefore, special attention shall be drawn to prevent the entering of water and the formation of condensate water.

3. Vacuum drying again for half an hour.

If the pressure reached -755mmHg, start to pressure leakage test. If it cannot reached the value, repeat vacuum damage and vacuum drying again for 1 hour.

4. Leakage test: After the vacuum degree reaches -755mmHg, stop vacuum drying and keep the pressure for 1 hour. If the indicator of vacuum gauge does not go up, it is qualified. If going up, it indicates that there is moisture or leak source.

8. Additional Refrigerant Charge

- After the vacuum drying process is carried out, the additional refrigerant charge process need to be performed.
- The outdoor unit is factory charged with refrigerant. The additional refrigerant charge volume is decided by the diameter and length of the liquid pipe between indoor and outdoor unit. Refer the following formula to calculate the charge volume.

Diameter of liquid pipe (mm)	Formula
6.35	$V=15g/m \times (L-5)$
9.52	$V=30g/m \times (L-5)$
12.7	$V=65g/m \times (L-5)$

V: Additional refrigerant charge volume (g).

L : The length of the liquid pipe (m).

Note:

- Refrigerant may only be charged after performed the vacuum drying process.
- Always use gloves and glasses to protect your hands and eyes during the charge work.
- Use electronic scale or fluid infusion apparatus to weight refrigerant to be recharged. Be sure to avoid extra refrigerant charged, it may cause liquid hammer of the compressor or protections.
- Use supplementing flexible pipe to connect refrigerant cylinder, pressure gauge and outdoor unit. And The refrigerant should be charged in liquid state. Before recharging, The air in the flexible pipe and manifold gauge should be exhausted.
- After finished refrigerant recharge process, check whether there is refrigerant leakage at the connection joint part.(Using gas leakage detector or soap water to detect).

9. Engineering of Insulation

9.1 Insulation of refrigerant pipe

1. Operational procedure of refrigerant pipe insulation

Cut the suitable pipe → insulation (except joint section) → flare the pipe → piping layout and connection → vacuum drying → insulate the joint parts

2. Purpose of refrigerant pipe insulation

- During operation, temperature of gas pipe and liquid pipe shall be over-heating or over-cooling extremely. Therefore, it is necessary to carry out insulation; otherwise it shall debase the performance of unit and burn compressor.
- Gas pipe temperature is very low during cooling. If insulation is not enough, it shall form dew and cause leakage.
- Temperature of gas pipe is very high (generally 50-100 °C) during heating. Insulation work must be carried out to prevent hurt by carelessness touching.

3. Insulation material selection for refrigerant pipe

- The burning performance should over 120 °C
- According to the local law to choose insulation materials
- The thickness of insulation layer shall be above 10mm. If in hot or wet environment place, the layer of insulation should be thicker accordingly.

4. Installation highlights of insulation construction

- Gas pipe and liquid pipe shall be insulated separately, if the gas pipe and liquid pipe were insulated together; it will decrease the performance of air conditioner.

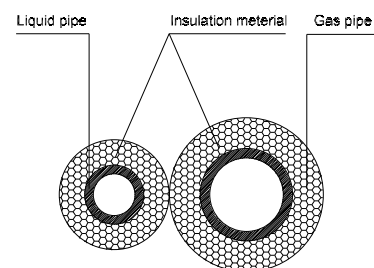

- The insulation material at the joint pipe shall be 5~10cm longer than the gap of the insulation material.
- The insulation material at the joint pipe shall be inserted into the gap of the insulation material.
- The insulation material at the joint pipe shall be banded to the gap pipe and liquid pipe tightly.
- The linking part should be use glue to paste together
- Be sure not bind the insulation material over-tight, it may extrude out the air in the material to cause bad

insulation and cause easy aging of the material.

9.2 Insulation of drainage pipe

1. Operational procedure of refrigerant pipe insulation

Select the suitable pipe → insulation (except joint section) → piping layout and connection → drainage test → insulate the joint parts

2. Purpose of drainage pipe insulation

The temperature of condensate drainage water is very low. If insulation is not enough, it shall form dew and cause leakage to damage the house decoration.

3. Insulation material selection for drainage pipe

- The insulation material should be flame retardant material, the flame retardancy of the material should be selected according to the local law.
- Thickness of insulation layer is usually above 10mm.
- Use specific glue to paste the seam of insulation material, and then bind with adhesive tape. The width of tape shall not be less than 5cm. Make sure it is firm and avoid dew.

4. Installation and highlights of insulation construction

- The single pipe should be insulated before connecting to another pipe, the joint part should be insulated after the drainage test.
- There should be no insulation gap between the insulation material.

10. Engineering of Electrical Wiring

10.1 Highlights of electrical wiring installation

- All field wiring construction should be finished by qualified electrician.
- Air conditioning equipment should be grounded according to the local electrical regulations.
- Current leakage protection switch should be installed.
- Do not connect the power wire to the terminal of signal wire.
- When power wire is parallel with signal wire, put wires to their own wire tube and remain at least 300mm gap.
- According to table in indoor part named “the specification of the power” to choose the wiring, make sure the selected wiring not small than the date showing in the table.
- Select different colors for different wire according to relevant regulations.
- Do not use metal wire tube at the place with acid or alkali corrosion, adopt plastic wire tube to replace it.
- There must be not wire connect joint in the wire tube If joint is a must, set a connection box at the place.
- The wiring with different voltage should not be in one wire tube.
- Ensure that the color of the wires of outdoor and the terminal No. are same as those of indoor unit respectively.
- You must first choose the right cable size before preparing it for connection. Be sure to use H07RN-F cables.

Table: Minimum Cross-Sectional Area able of Power and Signal Cables

Rated Current of Appliance (A)	Nominal Cross-Sectional Area(mm ²)
≤ 6	0.75
6 - 10	1
10 - 16	1.5
16 - 25	2.5
25 - 32	4
32 - 45	6

11. Test Operation

11.1 The test operation must be carried out after the entire installation has been completed.

11.2 Please confirm the following points before the test operation.

- The indoor unit and outdoor unit are installed properly.
- Tubing and wiring are correctly completed.
- The refrigerant pipe system is leakage-checked.
- The drainage is unimpeded.
- The ground wiring is connected correctly.
- The length of the tubing and the added stow capacity of the refrigerant have been recorded.
- The power voltage fits the rated voltage of the air conditioner.
- There is no obstacle at the outlet and inlet of the outdoor and indoor units.
- The gas-side and liquid-side stop valves are both opened.
- The air conditioner is pre-heated by turning on the power.

11.3 Test operation

1. Open both the liquid and gas stop valves.
2. Turn on the main power switch and allow the unit to warm up.
3. Set the air conditioner to COOL mode, and check the following points.

Indoor unit

- Whether the switch on the remote controller works well.
- Whether the buttons on the remote controller works well.
- Whether the air flow louver moves normally.
- Whether the room temperature is adjusted well.
- Whether the indicator lights normally.
- Whether the temporary buttons works well.
- Whether the drainage is normal.
- Whether there is vibration or abnormal noise during operation.

Outdoor unit

- Whether there is vibration or abnormal noise during operation.
- Whether the generated wind, noise, or condensed of by the air conditioner have influenced your neighborhood.
- Whether any of the refrigerant is leaked.

4. Drainage Test

- a. Ensure the drainpipe flows smoothly. New buildings should perform this test before finishing the ceiling.
- b. Remove the test cover. Add 2000ml of water to the tank through the attached tube.
- c. Turn on the main power switch and run the air conditioner in COOL mode.
- d. Listen to the sound of the drain pump to see if it makes any unusual noises.
- e. Check to see that the water is discharged. It may take up to one minute before the unit begins to drain depending on the drainpipe.
- f. Make sure that there are no leaks in any of the piping.
- g. Stop the air conditioner. Turn off the main power switch and reinstall the test cover.

Static Pressure Design

1.	Introduction	95
2.	Charts for friction losses in round ducts	95
3.	Dynamic losses.....	96
4.	Corresponding relation between Rectangular duct and Round Duct	97
5.	Method for duct calculation	98
6.	Unit conversion.....	98
7.	Recommended outlet velocity for different occasions	98

1. Introduction

Duct system losses are the irreversible transformation of mechanical energy into heat. The two types of losses are (1) friction losses and (2) dynamic losses.

Friction losses are due to fluid viscosity and result from momentum exchange between molecules (in laminar flow) or between individual particles of adjacent fluid layers moving at different velocities (in turbulent flow). Friction losses occur along the entire duct length.

Dynamic losses result from flow disturbances caused by duct mounted equipment and fittings (e.g., entries, exits, elbows, transitions, and junctions) that change the airflow path's direction or area.

2. Charts For Friction Losses In Round Ducts

Fluid resistance caused by friction in round ducts can be determined by the friction chart. (based on galvanized sheet)

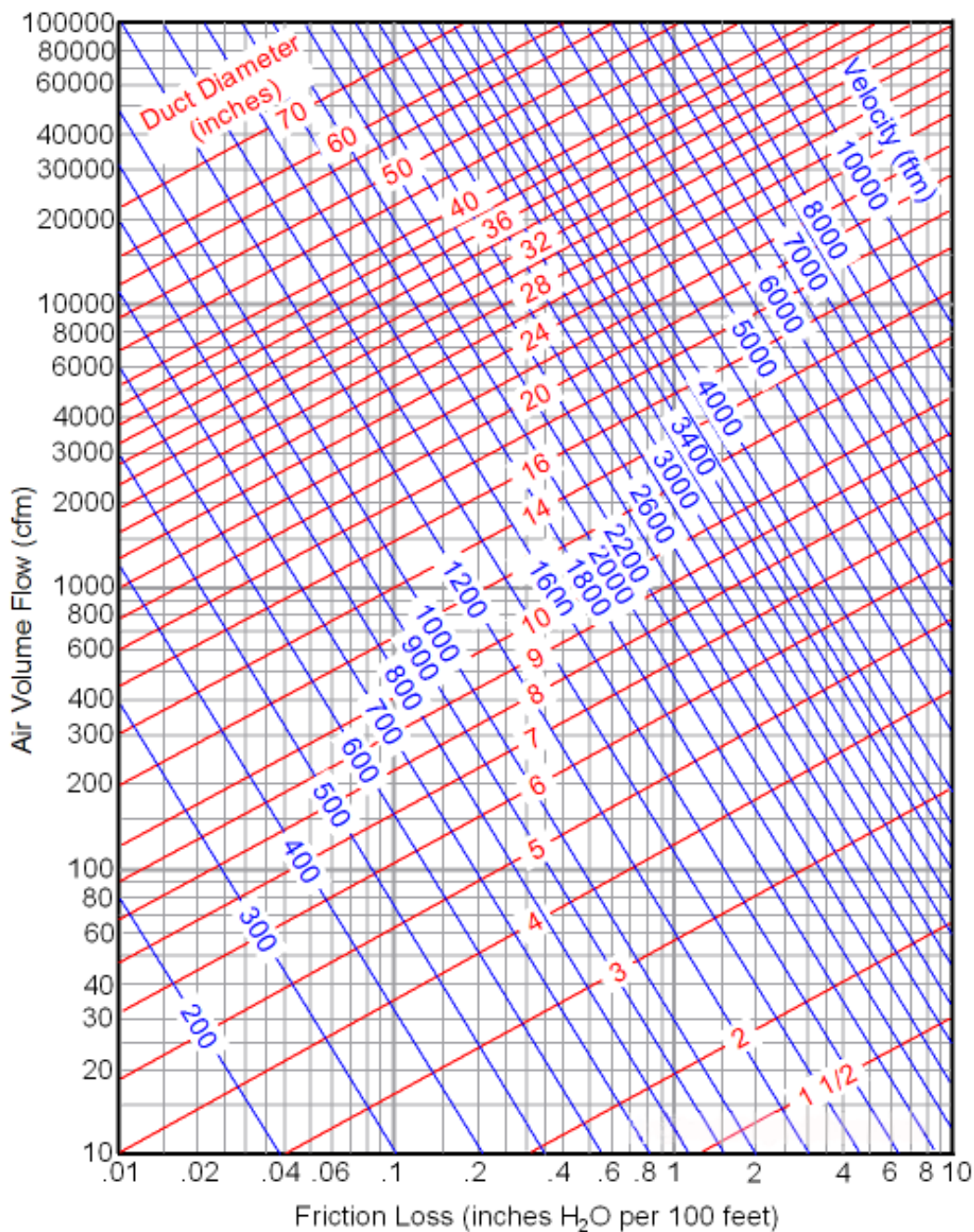

3. Dynamic Losses

For dynamic losses, please refer to below image.

Elbow ($r/w = 1$)		Sharp elbow ($r/w = 0.5$)		Branch Straight-Thru		Branch Thru-Branch ($r/w = 1$)		Reducer $\theta \leq 14^\circ$	
V m/s	loss mm H ₂ O	V m/s	loss mm H ₂ O	No friction loss		V m/s	loss mm H ₂ O	V m/s	loss mm H ₂ O
3.5~5	0.2	3.5~5	1			3.5~5	0.4	3.5~5	0.2
5~7	0.4	5~7	2			5~7	0.8	5~7	0.4
7~9	0.8	7~9	3.5			7~9	1.5	7~9	0.8
9~15	2	9~15	7			9~15	3	9~15	2
Anemostat		Gallery or louver		Register		Hopper			
V m/s	loss mm H ₂ O	V m/s	loss mm H ₂ O	V m/s	loss mm H ₂ O	V m/s	loss mm H ₂ O		
3.5~5	1	3.5~5	0.5	3.5~5	1.5	3.5~5	0.3		
5~7	2	5~7	1	5~7	3	5~7	0.6		
7~9	3.5	7~9	2	7~8	6	7~9	1		
9~15	6								

Note: W Shows a diameter of round duct or long side length of the rectangular duct.

4. Corresponding Relation Between Rectangular Duct and Round Duct

Circular Duct Diameter, in.	Length of One Side of Rectangular Duct, in.																			
	4	5	6	7	8	9	10	12	14	16	18	20	22	24	26	28	30	32	34	36
	Length Adjacent Side of Rectangular Duct, in.																			
5	5																			
5.5	6	5																		
6	8	6																		
6.5	9	7	6																	
7	11	8	7																	
7.5	13	10	8	7																
8	15	11	9	8																
8.5	17	13	10	9																
9	20	15	12	10	8															
9.5	22	17	13	11	9															
10	25	19	15	12	10	9														
10.5	29	21	16	14	12	10														
11	32	23	18	15	13	11	10													
11.5		26	20	17	14	12	11													
12		29	22	18	15	13	12													
12.5		32	24	20	17	15	13													
13		35	27	22	18	16	14	12												
13.5		38	29	24	20	17	15	13												
14			32	26	22	19	17	14												
14.5			35	28	24	20	18	15												
15			38	30	25	22	19	16	14											
16			45	36	30	25	22	18	15											
17				41	34	29	25	20	17	16										
18				47	39	33	29	23	19	17										
19				54	44	38	33	26	22	19	18									
20					50	43	37	29	24	21	19									
21					57	48	41	33	27	23	20									
22					64	54	46	36	30	26	23	20								
23						60	51	40	33	28	25	22								
24						66	57	44	36	31	27	24	22							
25							63	49	40	34	29	26	24							
26							69	54	44	37	32	28	26	24						
27							76	59	48	40	35	31	28	25						
28								64	52	43	38	33	30	27	26					
29								70	56	47	41	36	32	29	27					
30								76	61	51	44	39	35	31	29	28				
31								82	66	55	47	41	37	34	31	29				
32								89	71	59	51	44	40	36	33	31				
33								96	76	64	54	48	42	38	35	33	30			
34									82	68	58	51	45	41	37	35	32			
35									88	73	62	54	48	44	40	37	34	32		
36									95	78	67	58	51	46	42	39	36	34		
37									101	83	71	62	55	49	45	41	38	36	34	
38									108	89	76	66	58	52	47	44	40	38	36	
39										95	80	70	62	55	50	46	43	40	37	36
40										101	85	74	65	58	53	49	45	42	39	37
41										107	91	78	69	62	56	51	47	44	41	39
42										114	96	83	73	65	59	54	50	46	44	41
43										120	102	88	77	69	62	57	53	49	46	43
44											107	93	81	73	66	60	55	51	48	45
45											113	98	86	76	69	63	58	54	50	47
46											120	103	90	80	72	66	61	56	53	49
47											126	108	95	84	76	69	64	59	55	52
48											133	114	100	89	80	73	67	62	58	54
49											140	120	105	93	84	76	70	65	60	56
50											147	126	110	98	88	80	73	68	63	59
51											132	115	102	92	83	76	71	66	61	
52											139	121	107	96	87	80	74	69	64	
53											145	127	112	100	91	83	77	71	67	
54											152	133	117	105	95	87	80	74	70	
55												139	123	110	99	91	84	78	72	
56												145	128	114	104	95	87	81	75	
57												151	134	119	108	98	91	84	78	
58												158	139	124	112	102	94	87	81	
59												165	145	130	117	107	98	91	85	
60												172	151	135	122	111	102	94	88	

5. Method For Duct Calculation (equal friction method)

- 1) Draw schematic view of the duct system.
- 1) Make notes for air volume and mark clearly the elbow, the branch parts, the air discharge outlet.
- 1) Select one main ducting route (where the maximum static pressure loss occurs).
- 1) Select the air velocity for the main duct in accordance with the desirable air velocity.

Main duct	Typical design velocity (m/s)		
	Residence	Public building	Factory
	3.5~6.0	5.0~8.0	6.0~11.0

- 1) Since the velocity and air volume are fixed for main duct, then use the Friction loss chart to find standard friction loss.
- 1) Use air volume and friction loss to find corresponding duct size and velocity for each part of main duct through Frictions loss chart.
- 1) Find the dynamic loss of main ducting route according to the velocity. and type of special fittings (elbows, junctions, regulating flaps, etc.)
- 1) Obtain the duct size and velocity of each branch duct based on the air volume and the same standard friction loss as for the main duct.
- 1) Find the dynamic loss of branch duct.
- 1) Calculate the total pressure loss.

6. Unit Conversion

- 1 inch water=248.8 N/m² (Pa)=0.0361 lb/in² (psi)=25.4 kg/cm²=0.0739 in mercury
- 1 ft³/min (cfm)=1.7 m³/h
- 1 ft/min=5.08*10⁻³ m/s
- 1 inch=2.54 cm=0.0254m=0.08333ft

7. Recommended Outlet Velocity For Different Occasion

The permissible sound level and correspondingly maximum air velocity, is determined by the occasion.

Noise / dB(A)	Occasion	Maximum velocity / m/s
25	Studio, recording room	2
35	Cinema, hospital, library	3
40	Office, school, hotel	4
46	Bank, public hall	5
50	Store, post office	6
70	Factory	10

Airwell

Just feel well

WARNING :

The design and specifications are subject to change without prior notice for product improvement. Consult with the sales agency or manufacturer for details.

ATTENTION :

Le design et les données techniques sont donnés à titre indicatif et peuvent être modifiés sans préavis.



AIRWELL RESIDENTIAL SAS

10,Rue du Fort de Saint Cyr,
78180 Montigny le Bretonneux - France
www.airwell.com