

Airwell

CLIMATISATION ET CHAUFFAGE



Service Manual

Flow Logic III (T3) YDV T3 Series

R410A

English Manual



IMPORTANT NOTE:

Read this manual carefully before installing or operating your new air conditioning unit. Make sure to save this manual for future reference.

20.AW.YDVT3.R410A.SM.EN.05.16.Rev01

CONTENTS

1. General Information.....	1
1.1 Feature	1
1.2 Products Lineup.....	3
2. Specification	10
3. Dimension.....	38
4. Piping Diagram.....	40
5. Wiring Diagram.....	43
6. Capacity Calculation Due to Capacity Modification Coefficient.....	44
7. Operation Range	53
8. Noise Level.....	54
9. Installation	57
10. Branch Pipe Dimensions	87
11. Gather Pipe Dimension.....	89
12. Trial Operation	90
13. Outdoor PCB Photo.....	99
14. Outdoor PCB Dip Switch Setting.....	103
15. Outdoor system control function.....	113
16. Failure Code	117
17. Troubleshooting.....	124
18. Sensor Resistance Table.....	175
19. Fan Motor Installation and Detection Standard	183

1. General Information

1.1 Feature

1.1.1 Full DC inverter technology, high efficiency

- DC fan motor, efficiency 40% enhanced



- Full DC INVERTER scroll compressor, efficiency 5% enhanced



- 180° vector inverter, efficiency 5% enhanced



- Zigzag fan, to reduce the air vibration

- Two pieces condenser; Two-stage sub-cooling, added sub cooler in condenser

1.1.2 High reliable

- Back up running: Back up running available not only in combination system but also in single module system (with 2 compressors)



Back up running with different compressors in same system

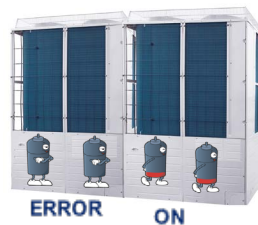

Back up running in different system

- Recycling operation, more long life of compressor
- 2 stage oil separator

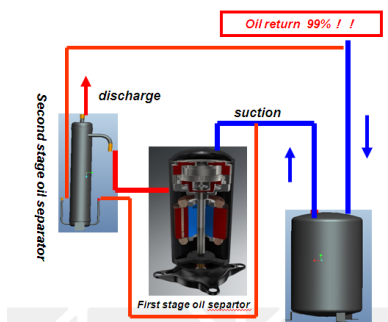

- Compressor double protection

Base on the basic air discharge sensor, YDV add the oil temperature sensor at the bottom of compressor.

- (1) Control the on/off of heater of compressor, preventing from the liquid shock of compressor.
- (2) Judge if the liquid refrigerant enters into the compressor.
- (3) Compressor oil sub heating protection.

- Thunder protection

There are electricity discharge wires in the terminal block, to lead the abnormal voltage into the earth, then to prevent the thunder design.

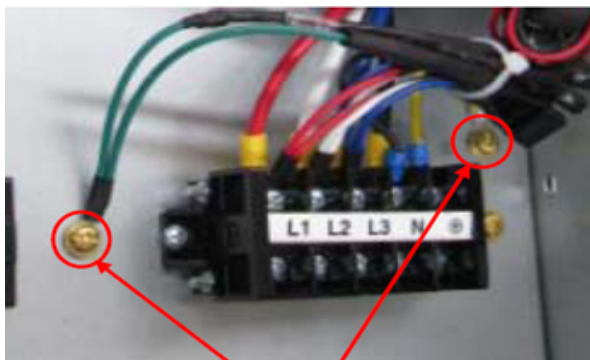

- Optimal temperature control

- (1) When a multiple number of indoor units are connected, an insufficient or excess amount of refrigerant may be supplied to indoor units depending on the difference in length of the piping connection from outdoor units.
- (2) Optimal refrigerant control uses the indoor coil temperature to detect the air conditioning status of each indoor unit and control the capacity (refrigerant amounts) very precisely.

1.1.3 Easy installation



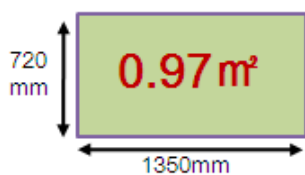

- Largest capacity: Single module reaches 24HP, max 3 modules combination capacity can reach 72HP.
- All the outdoor with same bottom size, 0.97m² Footprint of 72HP only 292m², 50% size reduced.







- Up to 82 Pa outdoor ESP, longer air duct connecting available.

1.2 Products Lineup

Outdoor units

Appearance	Power supply (Ph, V, Hz)	Model	Capacity (kW)	Refrigerant
	3Ph, 380-400V 50/60Hz	AW-YDV250HT-H16	25.20	R410A
		AW-YDV280HT-H16	28.00	
		AW-YDV335HT-H16	33.50	
		AW-YDV400HT-H16	40.00	
		AW-YDV450HT-H16	45.00	
		AW-YDV504HT-H16	50.00	
		AW-YDV560HT-H16	56.00	
		AW-YDV615HT-H16	61.50	
		AW-YDV680HT-H16	68.00	
		AW-YDV735HT-H16	73.50	
		AW-YDV800HT-H16	80.00	
		AW-YDV850HT-H16	85.00	
		AW-YDV904HT-H16	90.40	
		AW-YDV954HT-H16	106.40	
		AW-YDV1008HT-H16	112.00	
		AW-YDV1064HT-H16	117.50	
	AW-YDV1120HT-H16	124.00		

	3Ph, 380-400V 50/60Hz	AW-YDV1200HT-H16	120.00	R410A
		AW-YDV1250HT-H16	125.00	
		AW-YDV1304HT-H16	130.40	
		AW-YDV1354HT-H16	135.40	
		AW-YDV1408HT-H16	140.80	
		AW-YDV1460HT-H16	145.80	
		AW-YDV1512HT-H16	151.20	
		AW-YDV1570HT-H16	156.80	
		AW-YDV1624HT-H16	162.40	
		AW-YDV1680HT-H16	168.00	

Note:

The single module capacity range of Flow Logic III is from 8HP to 20 HP. In one system too much difference of capacity will cause of bad oil return.









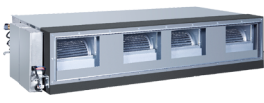

To protect the unit, adding the following limit in the PCB program of the outdoor unit:

In one system the difference of capacity between any two outdoor units can't be more than 4HP.

If in one system the difference of capacity is more than 4HP, the outdoor PCB will display "80" failure code and can't run.

Indoor units

<p>4-WAY CASSETTE TYPE</p> <p>AWSI-CBV005-N11 AWSI-CBV007-N11 AWSI-CBV009-N11 AWSI-CBV012-N11 AWSI-CBV016-N11 AWSI-CCV018-N11</p> 	<p>ROUND-WAY SMART AIR FLOW CASSETTE/ Panel for CFV</p> <p>AWSI-CFV007-N11 AWSI-CFV009-N11 AWSI-CFV012-N11 AWSI-CFV016-N11 AWSI-CFV018-N11</p>  <p>AWSI-CFV024-N11</p> <p>AWSI-CFV030-N11 AWSI-CFV038-N11</p> <p>AWSI-CFV048-N11 AWSI-CFV060-N11</p>
<p>4-WAY CASSETTE TYPE/CCV PANEL 90X90</p> <p>AWSI-CCV018-N11 AWSI-CCV024-N11</p> <p>AWSI-CCV030-N11 AWSI-CCV038-N11 AWSI-CCV048-N11</p> 	<p>ONE WAY CASSETTE TYPE/Panel for CDV to s12</p> <p>AWSI-CDV007-N11 AWSI-CDV009-N11 AWSI-CDV012-N11</p> 
<p>2-WAY CASSETTE TYPE</p> <p>AWSI-CEV009-N11 AWSI-CEV012-N11 AWSI-CEV016-N11 AWSI-CEV018-N11</p> 	<p>MED ESP DUCT TYPE (50/100Pa)</p> <p>AW-DBV030-N11 AW-DBV038-N11 AW-DBV048-N11</p> 
<p>SLIM LOW ESP DUCT</p> <p>AWSI-DDV007-N11 AWSI-DDV009-N11 AWSI-DDV012-N11 AWSI-DDV016-N11</p> <p>AWSI-DDV018-N11 AWSI-DDV024-N11</p> 	

<p>HIGH ESP DUCT TYPE</p> <p>AWSI-DCV018-N11 AWSI-DCV024-N11</p>  <p>AWSI-DCV030-N11 AWSI-DCV038-N11 AWSI-DCV048-N11</p>  <p>AWSI-DCV072-N11 AWSI-DCV096-N11</p> 	<p>CONVERTIBLE TYPE</p> <p>AWSI-FAV009-N11 AWSI-FAV012-N11 AWSI-FAV018-N11 AWSI-FAV024-N11</p>  <p>AWSI-FAV028-N11 AWSI-FAV030-N11 AWSI-FAV038-N11 AWSI-FAV048-N11</p> 
<p>HIGH WALL</p> <p>AWSI-HBV007-N11 AWSI-HBV009-N11 AWSI-HBV012-N11 AWSI-HBV012-N11 AWSI-HBV016-N11 AWSI-HBV018-N11 AWSI-HBV024-N11</p>  <p>AWSI-HBV030-N11</p>	<p>MED ESP DUCT TYPE (50/100Pa)</p> <p>AW-DBV005-N11 AW-DBV007-N11 AW-DBV009-N11 AW-DBV012-N11 AW-DBV016-N11</p>  <p>AW-DBV018-N11 AW-DBV024-N11 AW-DBV028-N11</p> 
<p>HRV</p> <p>AWSI-HRV0800-N11 AWSI-HRV1000-N11</p> 	<p>CONSOLE</p> <p>AW-EAV009-N11 AW-EAV012-N11 AW-EAV018-N11</p> 

2. Specification

Model		AW-YDV250HT-H16		AW-YDV280HT-H16	
Combination		/		/	
Power supply		Ph/V/Hz	3/380~400/50/60	3/380~400/50/60	
Cooling (T1)	Rated capacity	kW	25.2	28	
	Rated capacity	kBtu/h	86.0	95.5	
	Rated power input	kW	6.00	7.28	
	Max. power input	kW	16.91	17.65	
	EER		4.20	3.85	
	Rated current	A	10.13	12.29	
	Max. current	A	25.10	28.40	
Cooling (T3)	Rated capacity	kW	23.2	25.2	
	Rated power input	kW	7.02	8.66	
	Rated current	A	11.85	14.62	
Heating	Rated capacity	kW	27	33.5	
	Rated capacity	kBtu/h	9212	114.30	
	Rated power input	kW	5.85	7.32	
	Max. power input	kW	11.90	15.60	
	COP		4.62	4.58	
	Rated current	A	9.88	12.36	
	Max. current	A	19.00	25.20	
Capacity at low temperature	kW	21	25.6		
Compressor	Brand	MITSUBISHI ELECTRIC			
	Model	ANB52F		ANB52F	
	Type	DC INV. SCROLL		DC INV. SCROLL	
	Compressor quantity	1		1	
	Capacity	W	17200	17200	
	Power input	W	5250	5250	
	Rated current (RLA)	A	18.5	18.5	
	Speed	rps	60	60	
	Crankcase heater	W	38	38	
	Refrigerant oil brand	IDEMITSUKOSAN CO., LTD			
	Refrigerant oil type	FV50S		FV50S	
	Refrigerant oil charge	ml	2300+1000	2300+1000	
Outdoor fan motor	Brand	Match-Well		Match-Well	
	Model	MWS386-8K		MWS386-8K	
	Voltage	DC339		DC339	
	IP class	IP44		IP44	
	Type/quantity	DC/2		DC/2	
	Insulation class	E		E	
	Safe class	I		I	
	Power input	W	471*2	471*2	
	Output	W	386*2	386*2	
	Rated current	A	25*2	25*2	
	Capacitor	μF	/	/	
	Speed	rpm	200~1080	200~1080	
Outdoor fan	Brand	MHI		MHI	
	Model	/		/	
	Material	AS+20%GF		AS+20%GF	
	Type	Axial		Axial	
	Diameter	mm	Φ570×2	Φ570×2	
	Height	mm	202×2	202×2	

Model			AW-YDV250HT-H16	AW-YDV280HT-H16
Outdoor coil	Number of rows		2	2
	Tube pitch (a)×row pitch (b)	mm	25.4×19.05	25.4×19.05
	Fin spacing	mm	1.3	1.3
	Fin type (code)		Hydrophilic aluminum	
	Fin coating type	Optional	Clear lacquer	Clear lacquer
	Salt spray test duration	Hour	168	168
	Tube outside dia. and type		INNERGROOVE TUBE	
		mm	Φ8	Φ8
	Coil length×height	mm	(1648.2×812.8)*2	(1648.2×812.8)*2
Number of circuits		10*2	10*2	
Cabinet coating	Coating type		Powder Coating	Powder Coating
	Salt spray test duration	Hour	72	72
	Sheet metal material		Hot zinc plate	Hot zinc plate
	Sheet metal thickness	mm	0.8	0.8
Control panel enclosure IP class		Standard	IP24	IP24
Outdoor air flow (cooling/heating)		m ³ /h	15000/13200	15000/13200
External static pressure		Pa	82	82
Outdoor sound level (sound pressure level) (H)		dB (A)	57	57
Outdoor sound level (sound power level) (H)		dB (A)	73	73
Outdoor unit	Dimension (W*D*H)	mm	1350×720×1690	1350×720×1690
	Packing (W*D*H)	mm	1450×826×1885	1450×826×1885
	Net weight	kg	276	276
	Gross weight	kg	301	301
Refrigerant	Type		R410A	R410A
	Charged volume	kg	9.7	9.7
Throttle type			EXV	EXV
Design pressure		MPa	4.15	4.15
Refrigerant piping	Liquid pipe	mm	9.52	12.7
	Gas pipe	mm	22.22	25.4
	Oil pipe	mm	9.52	9.52
	Total pipe length	m	1000	1000
	Max. pipe length (Equivalent / actual)	m	190/165	190/165
	Max. Diff. indoor/outdoor unit*1		90 (Outdoor higher than indoor) 110 (Indoor higher than outdoor)	
	Standard Diff. indoor/outdoor unit	m	50 (Outdoor higher than indoor) 40 (Indoor higher than outdoor)	
	Max. / standard Diff. indoor/indoor unit*1	m	30 / 18	30 / 18
Connectable indoor unit ratio		%	50~130	50~130
Maximum indoor units		Piece	13	16
Connection wiring	Max. fuse current	A	40	40
	Min. wiring current	A	26.4	26.4
	Power wiring	mm ²	10	10
	Signal wiring	mm ²	2	
Operation range		°C	Cooling: -5~52 Heating: -23~18	
<p>Norminal condition: indoor temperature (cooling): 27DB (°C)/19WB (°C), indoor temperature (heating): 20DB (°C)/14.5WB (°C). Outdoor temperature (cooling): 35DB (°C)/24WB (°C), outdoor temperature (heating): 7DB (°C)/6WB (°C) The data is measured with 7.5m equivalent pipe and 0m height difference.</p> <p>The noise level will be measured in the third octave band limited values in the semi-anechoic chamber, using a Real Time Analyser calibrated sound intensity meter. It is a sound pressure noise level.</p> <p>*1 If the height difference between the outdoor and indoor units is from 50 to 110m or the height difference between the indoor units is from 18 to 30m, you Must contact your local distributor/dealer for individual design and production.</p>				

Model		AW-YDV335HT-H16		AW-YDV400HT-H16	
Combination		/		/	
Power supply		Ph/V/Hz	3/380~400/50/60		3/380~400/50/60
Cooling (T1)	Rated capacity	kW	33.5		40
	Rated capacity	kBtu/h	114.3		136.5
	Rated power input	kW	8.52		10.22
	Max. power input	kW	2268		24.36
	EER		3.93		3.91
	Rated current	A	14.38		17.25
	Max. current	A	3237		36.80
Cooling (T3)	Rated capacity	kW	28.5		32.8
	Rated power input	kW	9.76		11.45
	Rated current	A	16.48		19.33
Heating	Rated capacity	kW	37.8		45
	Rated capacity	kBtu/h	128.97		153.54
	Rated power input	kW	8.70		10.57
	Max. power input	kW	17.20		19.7
	COP		4.34		4.26
	Rated current	A	14.69		33.26
	Max. current	A	27.90		7.19
	Capacity at low temperature	kW	29		38
Compressor	Brand	MITSUBISHI ELECTRIC			
	Model	ANB66F		ANB42F*2	
	Type	DC INV. SCROLL		DC INV. SCROLL	
	Compressor quantity	1		2	
	Capacity	W	22000		13900+13900
	Power input	W	6500		4160+4160
	Rated current (RLA)	A	23.7		15.2+15.2
	Speed	rps	60		60
	Crankcase heater	W	38		38+38
	Refrigerant oil brand	IDEMITSUKOSAN CO., LTD			
	Refrigerant oil type	FV50S		FV50S	
	Refrigerant oil charge	ml	2300+1000		1700+1700+2000
Outdoor fan motor	Brand	Match-Well		Match-Well	
	Model	MWS386-8K		MWS386-8K	
	Voltage	DC339		DC339	
	IP class	IP44		IP44	
	Type/quantity	DC/2		DC/2	
	Insulation class	E		E	
	Safe class	I		I	
	Power input	W	471*2		471*2
	Output	W	386*2		386*2
	Rated current	A	25*2		25*2
	Capacitor	μF	/		/
	Speed	rpm	200~1080		200~1140
Outdoor fan	Brand	MHI		MHI	
	Model	/		/	
	Material	AS+20%GF		AS+20%GF	
	Type	Axial		Axial	
	Diameter	mm	Φ570×2		Φ570×2
	Height	mm	202×2		202×2

Model			AW-YDV335HT-H16	AW-YDV400HT-H16
Outdoor coil	Number of rows		2	2
	Tube pitch (a)×row pitch (b)	mm	25.4×19.05	25.4×19.05
	Fin spacing	mm	1.3	1.3
	Fin type (code)		Hydrophilic aluminum	
	Fin coating type	Optional	Clear lacquer	Clear lacquer
	Salt spray test duration	Hour	168	168
	Tube outside dia. and type		INNERGROOVE TUBE	
		mm	Φ8	Φ8
	Coil length×height	mm	(1648.2×812.8)*2	(1648.2×812.8)*2
Number of circuits		10*2	10*2	
Cabinet coating	Coating type		Powder Coating	Powder Coating
	Salt spray test duration	Hour	72	72
	Sheet metal material		Hot zinc plate	Hot zinc plate
	Sheet metal thickness	mm	0.8	0.8
Control panel enclosure IP class		Standard	IP24	IP24
Outdoor air flow (cooling/heating)		m ³ /h	15000/13200	15600/14400
External static pressure		Pa	82	82
Outdoor sound level (sound pressure level) (H)		dB (A)	57	58
Outdoor sound level (sound power level) (H)		dB (A)	73	74
Outdoor unit	Dimension (W*D*H)	mm	1350×720×1690	1350×720×1690
	Packing (W*D*H)	mm	1450×826×1885	1450×826×1885
	Net weight	kg	279	321
	Gross weight	kg	304	346
Refrigerant	Type		R410A	R410A
	Charged volume	kg	10	10
Throttle type			EXV	EXV
Design pressure		MPa	4.15	4.15
Refrigerant piping	Liquid pipe	mm	12.7	12.7
	Gas pipe	mm	28.58	28.58
	Oil pipe	mm	9.52	9.52
	Total pipe length	m	1000	1000
	Max. pipe length (Equivalent / actual)	m	190/165	190/165
	Max. Diff. indoor/outdoor unit*1		90 (Outdoor higher than indoor) 110 (Indoor higher than outdoor)	
	Standard Diff. indoor/outdoor unit	m	50 (Outdoor higher than indoor) 40 (Indoor higher than outdoor)	
	Max. / standard Diff. indoor/indoor unit*1	m	30 / 18	30 / 18
Connectable indoor unit ratio		%	50~130	50~130
Maximum indoor units		Piece	20	24
Connection wiring	Max. fuse current	A	50	60
	Min. wiring current	A	29.9	38.7
	Power wiring	mm ²	16	16
	Signal wiring	mm ²	2	
Operation range		°C	Cooling: -5~52 Heating: -23~18	
Norminal condition: indoor temperature (cooling): 27DB (°C)/19WB (°C), indoor temperature (heating): 20DB (°C)/14.5WB (°C). Outdoor temperature (cooling): 35DB (°C)/24WB (°C), outdoor temperature (heating): 7DB (°C)/6WB (°C) The data is measured with 7.5m equivalent pipe and 0m height difference. The noise level will be measured in the third octave band limited values in the semi-anechoic chamber, using a Real Time Analyser calibrated sound intensity meter. It is a sound pressure noise level. *1 If the height difference between the outdoor and indoor units is from 50 to 110m or the height difference between the indoor units is from 18 to 30m, you Must contact your local distributor/dealer for individual design and production.				

Model		AW-YDV450HT-H16	AW-YDV504HT-H16
Combination		/	/
Power supply		Ph/V/Hz	3/380~400/50/60
Cooling (T1)	Rated capacity	kW	45
	Rated capacity	kBtu/h	153.5
	Rated power input	kW	11.66
	Max. power input	kW	3230
	EER		3.86
	Rated current	A	19.68
	Max. current	A	54.53
Cooling (T3)	Rated capacity	kW	39.6
	Rated power input	kW	13.26
	Rated current	A	22.39
Heating	Rated capacity	kW	50
	Rated capacity	kBtu/h	170.60
	Rated power input	kW	11.95
	Max. power input	kW	23.80
	COP		4.18
	Rated current	A	20.17
	Max. current	A	38.00
	Capacity at low temperature	kW	41.5
Compressor	Brand	MITSUBISHI ELECTRIC	
	Model	ANB66F*2	ANB66F*2
	Type	DC INV. SCROLL	DC INV. SCROLL
	Compressor quantity	2	2
	Capacity	W	22000+22000
	Power input	W	6500+6500
	Rated current (RLA)	A	18.5+18.5
	Speed	rps	60
	Crankcase heater	W	38+38
	Refrigerant oil brand	IDEMITSUKOSAN CO., LTD	
	Refrigerant oil type	FV50S	FV50S
	Refrigerant oil charge	ml	2300+2300+2000
Outdoor fan motor	Brand	Match-Well	Match-Well
	Model	MWS386-8K	MWS386-8K
	Voltage	DC339	DC339
	IP class	IP44	IP44
	Type/quantity	DC/2	DC/2
	Insulation class	E	E
	Safe class	I	I
	Power input	W	471*2
	Output	W	386*2
	Rated current	A	25*2
	Capacitor	μF	/
	Speed	rpm	200~1180
	Outdoor fan	Brand	MHI
Model		/	/
Material		AS+20%GF	AS+20%GF
Type		Axial	Axial
Diameter		mm	Φ570×2
Height		mm	202×2

Model			AW-YDV450HT-H16	AW-YDV504HT-H16
Outdoor coil	Number of rows		2	2
	Tube pitch (a)×row pitch (b)	mm	25.4×19.05	25.4×19.05
	Fin spacing	mm	1.3	1.3
	Fin type (code)		Hydrophilic aluminum	
	Fin coating type	Optional	Clear lacquer	Clear lacquer
	Salt spray test duration	Hour	168	168
	Tube outside dia. and type		INNERGROOVE TUBE	
		mm	Φ8	Φ8
	Coil length×height	mm	(1648.2×1168.4+1648.2×812)*2	
Number of circuits		15*2	15*2	
Cabinet coating	Coating type		Powder Coating	Powder Coating
	Salt spray test duration	Hour	72	72
	Sheet metal material		Hot zinc plate	Hot zinc plate
	Sheet metal thickness	mm	0.8	0.8
Control panel enclosure IP class		Standard	IP24	IP24
Outdoor air flow (cooling/heating)		m ³ /h	16200/15000	16200/15000
External static pressure		Pa	82	82
Outdoor sound level (sound pressure level) (H)		dB (A)	59	60
Outdoor sound level (sound power level) (H)		dB (A)	76	77
Outdoor unit	Dimension (W*D*H)	mm	1350×720×2048	1350×720×2048
	Packing (W*D*H)	mm	1450×826×2225	1450×826×2225
	Net weight	kg	359	359
	Gross weight	kg	384	384
Refrigerant	Type		R410A	R410A
	Charged volume	kg	10	10
Throttle type			EXV	EXV
Design pressure		MPa	4.15	4.15
Refrigerant piping	Liquid pipe	mm	15.88	15.88
	Gas pipe	mm	28.58	28.58
	Oil pipe	mm	9.52	9.52
	Total pipe length	m	1000	1000
	Max. pipe length (Equivalent / actual)	m	190/165	190/165
	Max. Diff. indoor/outdoor unit*1		90 (Outdoor higher than indoor) 110 (Indoor higher than outdoor)	
	Standard Diff. indoor/outdoor unit	m	50 (Outdoor higher than indoor) 40 (Indoor higher than outdoor)	
	Max. / standard Diff. indoor/indoor unit*1	m	30 / 18	30 / 18
Connectable indoor unit ratio		%	50~130	50~130
Maximum indoor units		Piece	27	30
Connection wiring	Max. fuse current	A	80	80
	Min. wiring current	A	63.6	63.6
	Power wiring	mm ²	25	25
	Signal wiring	mm ²	2	
Operation range		°C	Cooling: -5~52 Heating: -23~18	
Norminal condition: indoor temperature (cooling): 27DB (°C)/19WB (°C), indoor temperature (heating): 20DB (°C)/14.5WB (°C). Outdoor temperature (cooling): 35DB (°C)/24WB (°C), outdoor temperature (heating): 7DB (°C)/6WB (°C) The data is measured with 7.5m equivalent pipe and 0m height difference. The noise level will be measured in the third octave band limited values in the semi-anechoic chamber, using a Real Time Analyser calibrated sound intensity meter. It is a sound pressure noise level. *1 If the height difference between the outdoor and indoor units is from 50 to 110m or the height difference between the indoor units is from 18 to 30m, you Must contact your local distributor/dealer for individual design and production.				

Model		AW-YDV560HT-H16		AW-YDV615HT-H16	
Combination				/	
Power supply		Ph/V/Hz		3/380~400/50/60	
Cooling (T1)	Rated capacity	kW	56	61.5	
	Rated capacity	kBtu/h	191.1	209.8	
	Rated power input	kW	15.20	15.8	
	Max. power input	kW	37.47	40.33	
	EER		3.68	3.89	
	Rated current	A	25.66	26.67	
	Max. current	A	60.50	60.77	
Cooling (T3)	Rated capacity	kW	44.8	53.7	
	Rated power input	kW	16.96	18.42	
	Rated current	A	28.63	31.10	
Heating	Rated capacity	kW	63	71.3	
	Rated capacity	kBtu/h	214.96	243.28	
	Rated power input	kW	15.40	16.02	
	Max. power input	kW	28.62	328	
	COP		4.09	4.45	
	Rated current	A	26.00	27.05	
	Max. current	A	47.40	53.10	
	Capacity at low temperature	kW	48.7	54.6	
Compressor	Brand	MITSUBISHI ELECTRIC			
	Model	ANB66F*2		ANB52F+ANB66F	
	Type	DC INV. SCROLL		DC INV. SCROLL	
	Compressor quantity	2		2	
	Capacity	W	22000+22000	17200+22000	
	Power input	W	6500+6500	5250+6500	
	Rated current (RLA)	A	18.5+18.5	18.5+18.5	
	Speed	rps	60	60	
	Crankcase heater	W	38+38	38+38	
	Refrigerant oil brand	IDEMITSUKOSAN CO., LTD			
	Refrigerant oil type	FV50S		FV50S	
	Refrigerant oil charge	ml	2300+2300+2000	2300+1000+2300+1000	
Outdoor fan motor	Brand	Match-Well		Match-Well	
	Model	MWS386-8K		MWS386-8K	
	Voltage	DC339		DC339	
	IP class	IP44		IP44	
	Type/quantity	DC/2		DC/4	
	Insulation class	E		E	
	Safe class	I		I	
	Power input	W	471*2	471*2+471*2	
	Output	W	386*2	386*2+386*2	
	Rated current	A	25*2	25*2+25*2	
	Capacitor	μF	/	/	
	Speed	rpm	200~1180	200~1080+200~1080	
Outdoor fan	Brand	MHI		MHI	
	Model	/		/	
	Material	AS+20%GF		AS+20%GF	
	Type	Axial		Axial	
	Diameter	mm	Φ570×2	Φ570×4	
	Height	mm	202×2	202×4	

Model			AW-YDV560HT-H16	AW-YDV615HT-H16
Outdoor coil	Number of rows		2	4
	Tube pitch (a)×row pitch (b)	mm	25.4×19.05	25.4×19.05
	Fin spacing	mm	1.3	1.3
	Fin type (code)		Hydrophilic aluminum	
	Fin coating type	Optional	Clear lacquer	Clear lacquer
	Salt spray test duration	Hour	168	168
	Tube outside dia. and type		INNERGROOVE TUBE	
		mm	Φ8	Φ8
	Coil length×height	mm	(1648.2×1168.4+1648.2×812)*2	(1648.2×812.8)*2+ (1648.2×812.8)*2
Number of circuits		15*2	10*2+10*2	
Cabinet coating	Coating type		Powder Coating	Powder Coating
	Salt spray test duration	Hour	72	72
	Sheet metal material		Hot zinc plate	Hot zinc plate
	Sheet metal thickness	mm	0.8	0.8
Control panel enclosure IP class		Standard	IP24	IP24
Outdoor air flow (cooling/heating)		m ³ /h	16200/15000	30000 / 26400
External static pressure		Pa	82	82
Outdoor sound level (sound pressure level) (H)		dB (A)	61	60
Outdoor sound level (sound power level) (H)		dB (A)	78	77
Outdoor unit	Dimension (W*D*H)	mm	1350×720×2048	(1350×720×1690)*2
	Packing (W*D*H)	mm	1450×826×2225	(1450×826×1885)*2
	Net weight	kg	359	555
	Gross weight	kg	384	605
Refrigerant	Type		R410A	R410A
	Charged volume	kg	10	19.7
Throttle type			EXV	EXV
Design pressure		MPa	4.15	4.15
Refrigerant piping	Liquid pipe	mm	15.88	19.05
	Gas pipe	mm	28.58	31.8
	Oil pipe	mm	9.52	9.52
	Total pipe length	m	1000	1000
	Max. pipe length (Equivalent / actual)	m	190/165	190/165
	Max. Diff. indoor/outdoor unit*1		90 (Outdoor higher than indoor) 110 (Indoor higher than outdoor)	
	Standard Diff. indoor/outdoor unit	m	50 (Outdoor higher than indoor) 40 (Indoor higher than outdoor)	
	Max. / standard Diff. indoor/indoor unit*1	m	30 / 18	30 / 18
Connectable indoor unit ratio		%	50~130	50~130
Maximum indoor units		Piece	33	36
Connection wiring	Max. fuse current	A	80	90
	Min. wiring current	A	63.6	56.3
	Power wiring	mm ²	25	/
	Signal wiring	mm ²	2	
Operation range		°C	Cooling: -5~52 Heating: -23~18	
Norminal condition: indoor temperature (cooling): 27DB (°C)/19WB (°C), indoor temperature (heating): 20DB (°C)/14.5WB (°C). Outdoor temperature (cooling): 35DB (°C)/24WB (°C), outdoor temperature (heating): 7DB (°C)/6WB (°C) The data is measured with 7.5m equivalent pipe and 0m height difference.				
The noise level will be measured in the third octave band limited values in the semi-anechoic chamber, using a Real Time Analyser calibrated sound intensity meter. It is a sound pressure noise level.				
*1 If the height difference between the outdoor and indoor units is from 50 to 110m or the height difference between the indoor units is from 18 to 30m, you Must contact your local distributor/dealer for individual design and production.				

Model			AW-YDV680HT-H16	AW-YDV735HT-H16
Combination			10+14	12+14
Power supply		Ph/V/Hz	3/380~400/50/60	3/380~400/50/60
Cooling (T1)	Rated capacity	kW	68	73.5
	Rated capacity	kBtu/h	2320	250.8
	Rated power input	kW	17.5	18.74
	Max. power input	kW	4201	47.04
	EER		3.89	3.92
	Rated current	A	29.54	31.64
	Max. current	A	65.2	69.17
Cooling (T3)	Rated capacity	kW	58.0	61.3
	Rated power input	kW	20.11	21.21
	Rated current	A	33.95	35.81
Heating	Rated capacity	kW	78.5	828
	Rated capacity	kBtu/h	267.84	28251
	Rated power input	kW	17.89	19.27
	Max. power input	kW	35.3	36.9
	COP		4.39	4.30
	Rated current	A	45.62	47.95
	Max. current	A	3239	35.09
	Capacity at low temperature	kW	63.6	67
Compressor	Brand		MITSUBISHI ELECTRIC	
	Model		ANB52F+ANB42F*2	ANB66F+ANB42F*2
	Type		DC INV. SCROLL	DC INV. SCROLL
	Compressor quantity		3	3
	Capacity	W	17200+(13900+13900)	22000+(13900+13900)
	Power input	W	5250+(4160+4160)	6500+(4160+4160)
	Rated current (RLA)	A	18.5+(15.2+15.2)	23.7+(18.5+18.5)
	Speed	rps	60	60
	Crankcase heater	W	38+(38+38)	38+(38+38)
	Refrigerant oil brand		IDEMITSUKOSAN CO., LTD	
	Refrigerant oil type		FV50S	FV50S
	Refrigerant oil charge	ml	2300+1000+(1700+1700+2000)	2300+1000+(2300+2300+2000)
Outdoor fan motor	Brand		Match-Well	Match-Well
	Model		MWS386-8K	MWS386-8K
	Voltage		DC339	DC339
	IP class		IP44	IP44
	Type/quantity		DC/4	DC/4
	Insulation class		E	E
	Safe class		I	I
	Power input	W	471*2+(471*2)	471*2+(471*2)
	Output	W	386*2+(386*2)	386*2+(386*2)
	Rated current	A	25*2+(25*2)	25*2+(25*2)
	Capacitor	μF	/	/
	Speed	rpm	200~1080+(200~1140)	200~1080+(200~1180)
Outdoor fan	Brand		MHI	MHI
	Model		/	/
	Material		AS+20%GF	AS+20%GF
	Type		Axial	Axial
	Diameter	mm	Φ570×4	Φ570×4
	Height	mm	202×4	202×4

Model			AW-YDV680HT-H16	AW-YDV735HT-H16
Outdoor coil	Number of rows		4	4
	Tube pitch (a)×row pitch (b)	mm	25.4×19.05	25.4×19.05
	Fin spacing	mm	1.3	1.3
	Fin type (code)		Hydrophilic aluminum	
	Fin coating type	Optional	Clear lacquer	Clear lacquer
	Salt spray test duration	Hour	168	168
	Tube outside dia. and type		INNERGROOVE TUBE	
		mm	Φ8	Φ8
	Coil length×height	mm	(1648.2×812.8)*2+ ((1648.2×812.8)*2)	(1648.2×812.8)*2+((1648.2× 1168.4+1648.2×812)*2)
Number of circuits		10*2+(10*2)	10*2+(15*2)	
Cabinet coating	Coating type		Powder Coating	Powder Coating
	Salt spray test duration	Hour	72	72
	Sheet metal material		Hot zinc plate	Hot zinc plate
	Sheet metal thickness	mm	0.8	0.8
Control panel enclosure IP class		Standard	IP24	IP24
Outdoor air flow (cooling/heating)		m ³ /h	30600 / 27600	30600 / 27600
External static pressure		Pa	82	82
Outdoor sound level (sound pressure level) (H)		dB (A)	60.5	60.5
Outdoor sound level (sound power level) (H)		dB (A)	78	78
Outdoor unit	Dimension (W*D*H)	mm	(1350×720×1690)*2	(1350×720×1690)*2
	Packing (W*D*H)	mm	(1450×826×1885)*2	(1450×826×1885)*2
	Net weight	kg	597	600
	Gross weight	kg	647	650
Refrigerant	Type		R410A	R410A
	Charged volume	kg	19.7	20
Throttle type			EXV	EXV
Design pressure		MPa	4.15	4.15
Refrigerant piping	Liquid pipe	mm	19.05	19.05
	Gas pipe	mm	31.8	31.8
	Oil pipe	mm	9.52	9.52
	Total pipe length	m	1000	1000
	Max. pipe length (Equivalent / actual)	m	190/165	190/165
	Max. Diff. indoor/outdoor unit*1		90 (Outdoor higher than indoor) 110 (Indoor higher than outdoor)	
	Standard Diff. indoor/outdoor unit	m	50 (Outdoor higher than indoor) 40 (Indoor higher than outdoor)	
	Max. / standard Diff. indoor/indoor unit*1	m	30 / 18	30 / 18
Connectable indoor unit ratio		%	50~130	50~130
Maximum indoor units		Piece	40	43
Connection wiring	Max. fuse current	A	100	110
	Min. wiring current	A	65.1	68.6
	Power wiring	mm ²	/	/
	Signal wiring	mm ²	2	
Operation range		°C	Cooling: -5~52 Heating: -23~18	
Norminal condition: indoor temperature (cooling): 27DB (°C)/19WB (°C), indoor temperature (heating): 20DB (°C)/14.5WB (°C). Outdoor temperature (cooling): 35DB (°C)/24WB (°C), outdoor temperature (heating): 7DB (°C)/6WB (°C) The data is measured with 7.5m equivalent pipe and 0m height difference.				
The noise level will be measured in the third octave band limited values in the semi-anechoic chamber, using a Real Time Analyser calibrated sound intensity meter. It is a sound pressure noise level.				
*1 If the height difference between the outdoor and indoor units is from 50 to 110m or the height difference between the indoor units is from 18 to 30m, you Must contact your local distributor/dealer for individual design and production.				

Model			AW-YDV800HT-H16	AW-YDV850HT-H16
Combination			14+14	14+16
Power supply		Ph/V/Hz	3/380~400/50/60	3/380~400/50/60
Cooling (T1)	Rated capacity	kW	80	85
	Rated capacity	kBtu/h	273.0	290.0
	Rated power input	kW	20.44	21.88
	Max. power input	kW	48.72	56.66
	EER		3.91	3.88
	Rated current	A	34.51	36.94
	Max. current	A	73.6	91.33
Cooling (T3)	Rated capacity	kW	65.6	72.4
	Rated power input	kW	22.90	24.71
	Rated current	A	38.66	41.72
Heating	Rated capacity	kW	90	95
	Rated capacity	kBtu/h	307.08	324.14
	Rated power input	kW	21.14	2252
	Max. power input	kW	39.4	43.5
	COP		4.26	4.22
	Rated current	A	66.52	53.43
	Max. current	A	14.37	45.19
	Capacity at low temperature	kW	76	79.5
Compressor	Brand		MITSUBISHI ELECTRIC	
	Model		ANB42F*2+ANB42F*2	ANB42F*2+ANB66F*2
	Type		DC INV. SCROLL	DC INV. SCROLL
	Compressor quantity		4	4
	Capacity	W	13900+13900*2	13900+13900+(22000+22000)
	Power input	W	(4160+4160)*2	(4160+4160)+(6500+6500)
	Rated current (RLA)	A	(18.5+18.5)*2	(15.2+15.2)+(18.5+18.5)
	Speed	rps	60	60
	Crankcase heater	W	(38+38)*2	(38+38)+(38+38)
	Refrigerant oil brand		IDEMITSUKOSAN CO., LTD	
	Refrigerant oil type		FV50S	FV50S
	Refrigerant oil charge	ml	(2300+2300+2000)*2	(1700+1700+2000)+(2300+2300+2000)
Outdoor fan motor	Brand		Match-Well	Match-Well
	Model		MWS386-8K	MWS386-8K
	Voltage		DC339	DC339
	IP class		IP44	IP44
	Type/quantity		DC/4	DC/4
	Insulation class		E	E
	Safe class		I	I
	Power input	W	(471*2)*2	(471*2)+(471*2)
	Output	W	(386*2)*2	(386*2)+(386*2)
	Rated current	A	(25*2)*2	(25*2)+(25*2)
	Capacitor	μF	/	/
	Speed	rpm	(200~1180)*2	(200~1140)+(200~1180)
Outdoor fan	Brand		MHI	MHI
	Model		/	/
	Material		AS+20%GF	AS+20%GF
	Type		Axial	Axial
	Diameter	mm	Φ570×4	Φ570×4
	Height	mm	202×4	202×4

Model			AW-YDV800HT-H16	AW-YDV850HT-H16
Outdoor coil	Number of rows		4	4
	Tube pitch (a)×row pitch (b)	mm	25.4×19.05	25.4×19.05
	Fin spacing	mm	1.3	1.3
	Fin type (code)		Hydrophilic aluminum	
	Fin coating type	Optional	Clear lacquer	Clear lacquer
	Salt spray test duration	Hour	168	168
	Tube outside dia. and type		INNERGROOVE TUBE	
		mm	Φ8	Φ8
	Coil length×height	mm	((1648.2×1168.4+1648.2×812)*2)*2	((1648.2×812.8)*2)+((1648.2×1168.4+1648.2×812)*2)
Number of circuits		(15*2)*2	(10*2)+(15*2)	
Cabinet coating	Coating type		Powder Coating	Powder Coating
	Salt spray test duration	Hour	72	72
	Sheet metal material		Hot zinc plate	Hot zinc plate
	Sheet metal thickness	mm	0.8	0.8
Control panel enclosure IP class		Standard	IP24	IP24
Outdoor air flow (cooling/heating)		m ³ /h	31200 / 28800	31800 / 29400
External static pressure		Pa	82	82
Outdoor sound level (sound pressure level) (H)		dB (A)	61	61.5
Outdoor sound level (sound power level) (H)		dB (A)	78	79
Outdoor unit	Dimension (W*D*H)	mm	1350×720×1690+1350×720×2048	1350×720×1690+1350×720×2048
	Packing (W*D*H)	mm	(1450×826×1885)*2	1450×826×1885+1450×826×2225
	Net weight	kg	642	680
	Gross weight	kg	692	730
Refrigerant	Type		R410A	R410A
	Charged volume	kg	20	20
Throttle type			EXV	EXV
Design pressure		MPa	4.15	4.15
Refrigerant piping	Liquid pipe	mm	19.05	19.05
	Gas pipe	mm	31.8	38.1
	Oil pipe	mm	9.52	9.52
	Total pipe length	m	1000	1000
	Max. pipe length (Equivalent / actual)	m	190/165	190/165
	Max. Diff. indoor/outdoor unit*1		90 (Outdoor higher than indoor) 110 (Indoor higher than outdoor)	
	Standard Diff. indoor/outdoor unit	m	50 (Outdoor higher than indoor) 40 (Indoor higher than outdoor)	
	Max. / standard Diff. indoor/indoor unit*1	m	30 / 18	30 / 18
Connectable indoor unit ratio		%	50~130	50~130
Maximum indoor units		Piece	46	50
Connection wiring	Max. fuse current	A	120	140
	Min. wiring current	A	77.4	1023
	Power wiring	mm ²	/	/
	Signal wiring	mm ²	2	
Operation range		°C	Cooling: -5~52 Heating: -23~18	
Norminal condition: indoor temperature (cooling): 27DB (°C)/19WB (°C), indoor temperature (heating): 20DB (°C)/14.5WB (°C). Outdoor temperature (cooling): 35DB (°C)/24WB (°C), outdoor temperature (heating): 7DB (°C)/6WB (°C) The data is measured with 7.5m equivalent pipe and 0m height difference.				
The noise level will be measured in the third octave band limited values in the semi-anechoic chamber, using a Real Time Analyser calibrated sound intensity meter. It is a sound pressure noise level.				
*1 If the height difference between the outdoor and indoor units is from 50 to 110m or the height difference between the indoor units is from 18 to 30m, you Must contact your local distributor/dealer for individual design and production.				

Model		AW-YDV904HT-H16	AW-YDV954HT-H16	
Combination		14+18	16+18	
Power supply		Ph/V/Hz	3/380~400/50/60	
Cooling (T1)	Rated capacity	kW	90.4	
	Rated capacity	kBtu/h	308.4	
	Rated power input	kW	23.47	
	Max. power input	kW	59.6	
	EER		3.85	
	Rated current	A	39.62	
	Max. current	A	93.4	
Cooling (T3)	Rated capacity	kW	75.6	
	Rated power input	kW	26.70	
	Rated current	A	45.08	
Heating	Rated capacity	kW	103.5	
	Rated capacity	kBtu/h	353.14	
	Rated power input	kW	24.62	
	Max. power input	kW	44.9	
	COP		4.20	
	Rated current	A	56.98	
	Max. current	A	49.49	
	Capacity at low temperature	kW	81.7	
Compressor	Brand	MITSUBISHI ELECTRIC		
	Model	ANB42F*2+ANB66F*2	ANB66F*2+ANB66F*2	
	Type	DC INV. SCROLL		
	Compressor quantity	4		
	Capacity	W	13900+13900+(22000+22000)	(22000+22000)*2
	Power input	W	(4160+4160)+(6500+6500)	(6500+6500)+(6500+6500)
	Rated current (RLA)	A	(15.2+15.2)+(18.5+18.5)	(18.5+18.5)+(18.5+18.5)
	Speed	rps	60	
	Crankcase heater	W	(38+38)+(38+38)	(38+38)+(38+38)
	Refrigerant oil brand	IDEMITSUKOSAN CO., LTD		
	Refrigerant oil type	FV50S		
	Refrigerant oil charge	ml	(1700+1700+2000)+(2300+2300+2000)	(2300+2300+2000)+(2300+2300+2000)
Outdoor fan motor	Brand	Match-Well		
	Model	MWS386-8K		
	Voltage	DC339		
	IP class	IP44		
	Type/quantity	DC/4		
	Insulation class	E		
	Safe class	I		
	Power input	W	(471*2)+(471*2)	(471*2)+(471*2)
	Output	W	(386*2)+(386*2)	(386*2)+(386*2)
	Rated current	A	(25*2)+(25*2)	(25*2)+(25*2)
	Capacitor	μF	/	
	Speed	rpm	(200~1140)+(200~1180)	(200~1180)+(200~1180)
Outdoor fan	Brand	MHI		
	Model	/		
	Material	AS+20%GF		
	Type	Axial		
	Diameter	mm	Φ570×4	
	Height	mm	202×4	

Model		AW-YDV904HT-H16	AW-YDV954HT-H16	
Outdoor coil	Number of rows		4	
	Tube pitch (a)×row pitch (b)	mm	25.4×19.05	
	Fin spacing	mm	1.3	
	Fin type (code)		Hydrophilic aluminum	
	Fin coating type	Optional	Clear lacquer	Clear lacquer
	Salt spray test duration	Hour	168	168
	Tube outside dia. and type		INNERGROOVE TUBE	
		mm	Φ8	Φ8
Coil length×height	mm	$((1648.2 \times 812.8) \times 2) + ((1648.2 \times 1168.4 + 1648.2 \times 812) \times 2)$	$((1648.2 \times 1168.4 + 1648.2 \times 812) \times 2) + ((1648.2 \times 812.8) \times 2)$	
Number of circuits		$(10 \times 2) + (15 \times 2)$	$(15 \times 2) + (15 \times 2)$	
Cabinet coating	Coating type		Powder Coating	
	Salt spray test duration	Hour	72	
	Sheet metal material		Hot zinc plate	
	Sheet metal thickness	mm	0.8	
Control panel enclosure IP class	Standard	IP24	IP24	
Outdoor air flow (cooling/heating)	m ³ /h	31800 / 29400	32400 / 30000	
External static pressure	Pa	82	82	
Outdoor sound level (sound pressure level) (H)	dB (A)	62	625	
Outdoor sound level (sound power level) (H)	dB (A)	79	80	
Outdoor unit	Dimension (W*D*H)	mm	1350×720×1690+1350×720×2048	
	Packing (W*D*H)	mm	1450×826×1885+1450×826×2225	
	Net weight	kg	680	
	Gross weight	kg	730	
Refrigerant	Type		R410A	
	Charged volume	kg	20	
Throttle type		EXV	EXV	
Design pressure	MPa	4.15	4.15	
Refrigerant piping	Liquid pipe	mm	19.05	
	Gas pipe	mm	38.1	
	Oil pipe	mm	9.52	
	Total pipe length	m	1000	
	Max. pipe length (Equivalent / actual)	m	190/165	
	Max. Diff. indoor/outdoor unit*1		90 (Outdoor higher than indoor) 110 (Indoor higher than outdoor)	
	Standard Diff. indoor/outdoor unit	m	50 (Outdoor higher than indoor) 40 (Indoor higher than outdoor)	
	Max. / standard Diff. indoor/indoor unit*1	m	30 / 18	30 / 18
Connectable indoor unit ratio	%	50~130	50~130	
Maximum indoor units	Piece	53	57	
Connection wiring	Max. fuse current	A	140	
	Min. wiring current	A	1023	
	Power wiring	mm ²	/	
	Signal wiring	mm ²	2	
Operation range	°C	Cooling: -5~52 Heating: -23~18		
Norminal condition: indoor temperature (cooling): 27DB (°C)/19WB (°C), indoor temperature (heating): 20DB (°C)/14.5WB (°C). Outdoor temperature (cooling): 35DB (°C)/24WB (°C), outdoor temperature (heating): 7DB (°C)/6WB (°C) The data is measured with 7.5m equivalent pipe and 0m height difference. The noise level will be measured in the third octave band limited values in the semi-anechoic chamber, using a Real Time Analyser calibrated sound intensity meter. It is a sound pressure noise level. *1 If the height difference between the outdoor and indoor units is from 50 to 110m or the height difference between the indoor units is from 18 to 30m, you Must contact your local distributor/dealer for individual design and production.				

Model		AW-YDV1008HT-H16	AW-YDV1064HT-H16
Combination		18+18	18+20
Power supply		Ph/V/Hz	3/380~400/50/60
Cooling (T1)	Rated capacity	kW	100.8
	Rated capacity	kBtu/h	343.9
	Rated power input	kW	26.5
	Max. power input	kW	70.48
	EER		3.80
	Rated current	A	44.74
	Max. current	A	113.2
Cooling (T3)	Rated capacity	kW	85.6
	Rated power input	kW	30.50
	Rated current	A	51.49
Heating	Rated capacity	kW	117
	Rated capacity	kBtu/h	399.20
	Rated power input	kW	28.1
	Max. power input	kW	50.4
	COP		4.16
	Rated current	A	47.44
	Max. current	A	84.60
	Capacity at low temperature	kW	87.4
Compressor	Brand	MITSUBISHI ELECTRIC	
	Model	ANB66F*2+ANB66F*2	ANB66F*2+ANB66F*2
	Type	DC INV. SCROLL	DC INV. SCROLL
	Compressor quantity	4	4
	Capacity	W	(22000+22000)*2
	Power input	W	(6500+6500)+(6500+6500)
	Rated current (RLA)	A	(18.5+18.5)*2
	Speed	rps	60
	Crankcase heater	W	(38+38)*2
	Refrigerant oil brand	IDEMITSUKOSAN CO., LTD	
	Refrigerant oil type	FV50S	FV50S
	Refrigerant oil charge	ml	(2300+2300+2000)*2
Outdoor fan motor	Brand	Match-Well	Match-Well
	Model	MWS386-8K	MWS386-8K
	Voltage	DC339	DC339
	IP class	IP44	IP44
	Type/quantity	DC/4	DC/4
	Insulation class	E	E
	Safe class	I	I
	Power input	W	(471*2)*2
	Output	W	(386*2)*2
	Rated current	A	(25*2)*2
	Capacitor	μF	/
	Speed	rpm	(200~1180)*2
Outdoor fan	Brand	MHI	MHI
	Model	/	/
	Material	AS+20%GF	AS+20%GF
	Type	Axial	Axial
	Diameter	mm	Φ570×4
	Height	mm	202×4

Model		AW-YDV1008HT-H16	AW-YDV1064HT-H16	
Outdoor coil	Number of rows		4	
	Tube pitch (a)×row pitch (b)	mm	25.4×19.05	
	Fin spacing	mm	1.3	
	Fin type (code)		Hydrophilic aluminum	
	Fin coating type	Optional	Clear lacquer	Clear lacquer
	Salt spray test duration	Hour	168	168
	Tube outside dia. and type		INNERGROOVE TUBE	
		mm	φ8	φ8
	Coil length×height	mm	((1648.2×1168.4+1648.2×812)*2)*2	((1648.2×1168.4+1648.2×812)*2)+((1648.2×1168.4+1648.2×812)*2)
Number of circuits		(15*2)*2	(15*2)+(15*2)	
Cabinet coating	Coating type		Powder Coating	
	Salt spray test duration	Hour	72	
	Sheet metal material		Hot zinc plate	
	Sheet metal thickness	mm	0.8	
Control panel enclosure IP class		Standard	IP24	
Outdoor air flow (cooling/heating)		m ³ /h	32400 / 30000	
External static pressure		Pa	82	
Outdoor sound level (sound pressure level) (H)		dB (A)	63	
Outdoor sound level (sound power level) (H)		dB (A)	80	
Outdoor unit	Dimension (W*D*H)	mm	(1350×720×2048)*2	
	Packing (W*D*H)	mm	(1450×826×2225)*2	
	Net weight	kg	718	
	Gross weight	kg	768	
Refrigerant	Type		R410A	
	Charged volume	kg	20	
Throttle type			EXV	
Design pressure		MPa	4.15	
Refrigerant piping	Liquid pipe	mm	19.05	
	Gas pipe	mm	38.1	
	Oil pipe	mm	9.52	
	Total pipe length	m	1000	
	Max. pipe length (Equivalent / actual)	m	190/165	
	Max. Diff. indoor/outdoor unit*1		90 (Outdoor higher than indoor) 110 (Indoor higher than outdoor)	
	Standard Diff. indoor/outdoor unit	m	50 (Outdoor higher than indoor) 40 (Indoor higher than outdoor)	
	Max. / standard Diff. indoor/indoor unit*1	m	30 / 18	
Connectable indoor unit ratio		%	50~130	
Maximum indoor units		Piece	60	
Connection wiring	Max. fuse current	A	160	
	Min. wiring current	A	127.2	
	Power wiring	mm ²	/	
	Signal wiring	mm ²	2	
Operation range		°C	Cooling: -5~52 Heating: -23~18	
<p>Normal condition: indoor temperature (cooling): 27DB (°C)/19WB (°C), indoor temperature (heating): 20DB (°C)/14.5WB (°C). Outdoor temperature (cooling): 35DB (°C)/24WB (°C), outdoor temperature (heating): 7DB (°C)/6WB (°C) The data is measured with 7.5m equivalent pipe and 0m height difference.</p> <p>The noise level will be measured in the third octave band limited values in the semi-anechoic chamber, using a Real Time Analyser calibrated sound intensity meter. It is a sound pressure noise level.</p> <p>*1 If the height difference between the outdoor and indoor units is from 50 to 110m or the height difference between the indoor units is from 18 to 30m, you Must contact your local distributor/dealer for individual design and production.</p>				

Model		AW-YDV1120HT-H16		AW-YDV1200HT-H16	
Combination		20+20		14+14+14	
Power supply		Ph/V/Hz	3/380~400/50/60		3/380~400/50/60
Cooling (T1)	Rated capacity	kW	112		120
	Rated capacity	kBtu/h	3821		409.4
	Rated power input	kW	30.4		30.66
	Max. power input	kW	74.94		73.08
	EER		3.68		3.91
	Rated current	A	51.32		51.76
	Max. current	A	121		110.4
Cooling (T3)	Rated capacity	kW	89.6		98.4
	Rated power input	kW	33.92		34.35
	Rated current	A	57.26		57.99
Heating	Rated capacity	kW	126		135
	Rated capacity	kBtu/h	429.91		460.62
	Rated power input	kW	30.8		31.71
	Max. power input	kW	57.24		59.1
	COP		4.09		4.26
	Rated current	A	5200		99.77
	Max. current	A	94.80		21.56
	Capacity at low temperature	kW	97.4		114
Compressor	Brand	MITSUBISHI ELECTRIC			
	Model	ANB66F*2+ANB66F*2		ANB42F*2+ANB42F*2+ANB42F*2	
	Type	DC INV. SCROLL		DC INV. SCROLL	
	Compressor quantity	4		6	
	Capacity	W	(22000+22000)*2		(13900+13900)*3
	Power input	W	(6500+6500)+(6500+6500)		(4160+4160)*3
	Rated current (RLA)	A	(18.5+18.5)*2		(15.2+15.2)*3
	Speed	rps	60		60
	Crankcase heater	W	(38+38)*2		(38+38)*3
	Refrigerant oil brand	IDEMITSUKOSAN CO., LTD			
	Refrigerant oil type	FV50S		FV50S	
	Refrigerant oil charge	ml	(2300+2300+2000)*2		(1700+1700+2000)*3
Outdoor fan motor	Brand	Match-Well		Match-Well	
	Model	MWS386-8K		MWS386-8K	
	Voltage	DC339		DC339	
	IP class	IP44		IP44	
	Type/quantity	DC/4		DC/6	
	Insulation class	E		E	
	Safe class	I		I	
	Power input	W	(471*2)*2		(471*2)*3
	Output	W	(386*2)*2		(386*2)*3
	Rated current	A	(25*2)*2		(25*2)*3
	Capacitor	μF	/		/
	Speed	rpm	(200~1180)*2		(200~1140)*3
	Outdoor fan	Brand	MHI		MHI
Model		/		/	
Material		AS+20%GF		AS+20%GF	
Type		Axial		Axial	
Diameter		mm	Φ570×4		Φ570×6
Height		mm	202×4		202×6

Model			AW-YDV1120HT-H16	AW-YDV1200HT-H16
Outdoor coil	Number of rows		4	6
	Tube pitch (a)×row pitch (b)	mm	25.4×19.05	25.4×19.05
	Fin spacing	mm	1.3	1.3
	Fin type (code)		Hydrophilic aluminum	
	Fin coating type	Optional	Clear lacquer	Clear lacquer
	Salt spray test duration	Hour	168	168
	Tube outside dia. and type		INNERGROOVE TUBE	
		mm	Φ8	Φ8
	Coil length×height	mm	((1648.2×1168.4+ 1648.2×812)*2)*2	((1648.2×812.8)*2)*3
Number of circuits		(15*2)*2	(10*2)*3	
Cabinet coating	Coating type		Powder Coating	Powder Coating
	Salt spray test duration	Hour	72	72
	Sheet metal material		Hot zinc plate	Hot zinc plate
	Sheet metal thickness	mm	0.8	0.8
Control panel enclosure IP class		Standard	IP24	IP24
Outdoor air flow (cooling/heating)		m ³ /h	32400 / 30000	46800 / 43200
External static pressure		Pa	82	82
Outdoor sound level (sound pressure level) (H)		dB (A)	65	63
Outdoor sound level (sound power level) (H)		dB (A)	83	81
Outdoor unit	Dimension (W*D*H)	mm	(1350×720×2048)*2	1350×720×2048+(1350×720×1690)*3
	Packing (W*D*H)	mm	(1450×826×2225)*2	(1450×826×1885)*3
	Net weight	kg	718	963
	Gross weight	kg	768	1038
Refrigerant	Type		R410A	R410A
	Charged volume	kg	20	30
Throttle type			EXV	EXV
Design pressure		MPa	4.15	4.15
Refrigerant piping	Liquid pipe	mm	19.05	19.05
	Gas pipe	mm	38.1	38.1
	Oil pipe	mm	9.52	9.52
	Total pipe length	m	1000	1000
	Max. pipe length (Equivalent / actual)	m	190/165	190/165
	Max. Diff. indoor/outdoor unit*1		90 (Outdoor higher than indoor) 110 (Indoor higher than outdoor)	
	Standard Diff. indoor/outdoor unit	m	50 (Outdoor higher than indoor) 40 (Indoor higher than outdoor)	
	Max. / standard Diff. indoor/indoor unit*1	m	30 / 18	30 / 18
Connectable indoor unit ratio		%	50~130	50~130
Maximum indoor units		Piece	64	64
Connection wiring	Max. fuse current	A	160	180
	Min. wiring current	A	127.2	116.1
	Power wiring	mm ²	/	/
	Signal wiring	mm ²	2	
Operation range		°C	Cooling: -5~52 Heating: -23~18	
Norminal condition: indoor temperature (cooling): 27DB (°C)/19WB (°C), indoor temperature (heating): 20DB (°C)/14.5WB (°C). Outdoor temperature (cooling): 35DB (°C)/24WB (°C), outdoor temperature (heating): 7DB (°C)/6WB (°C) The data is measured with 7.5m equivalent pipe and 0m height difference.				
The noise level will be measured in the third octave band limited values in the semi-anechoic chamber, using a Real Time Analyser calibrated sound intensity meter. It is a sound pressure noise level.				
*1 If the height difference between the outdoor and indoor units is from 50 to 110m or the height difference between the indoor units is from 18 to 30m, you Must contact your local distributor/dealer for individual design and production.				

Model		AW-YDV1250HT-H16		AW-YDV1304HT-H16	
Combination			14+14+16	14+14+18	
Power supply		Ph/V/Hz	3/380~400/50/60	3/380~400/50/60	
Cooling (T1)	Rated capacity	kW	125	130.4	
	Rated capacity	kBtu/h	426.5	444.9	
	Rated power input	kW	321	33.69	
	Max. power input	kW	81.02	83.96	
	EER		3.89	3.87	
	Rated current	A	54.19	56.88	
	Max. current	A	128.13	130.2	
Cooling (T3)	Rated capacity	kW	105.2	108.4	
	Rated power input	kW	37.07	38.53	
	Rated current	A	62.58	65.05	
Heating	Rated capacity	kW	140	148.5	
	Rated capacity	kBtu/h	477.68	506.68	
	Rated power input	kW	33.09	35.19	
	Max. power input	kW	63.2	64.6	
	COP		4.23	4.22	
	Rated current	A	86.69	90.23	
	Max. current	A	5237	56.67	
	Capacity at low temperature	kW	117.5	119.7	
Compressor	Brand		MITSUBISHI ELECTRIC		
	Model		ANB42F*2+ANB42F*2+ANB66F*2	ANB42F*2+ANB42F*2+ANB66F*2	
	Type		DC INV. SCROLL	DC INV. SCROLL	
	Compressor quantity		6	6	
	Capacity	W	(13900+13900)*2+(22000+22000)	(13900+13900)*2+(22000+22000)	
	Power input	W	(4160+4160)*2+(6500+6500)	(4160+4160)*2+(6500+6500)	
	Rated current (RLA)	A	(15.2+15.2)*2+(18.5+18.5)	(15.2+15.2)*2+(18.5+18.5)	
	Speed	rps	60	60	
	Crankcase heater	W	(38+38)*2+(38+38)	(38+38)*2+(38+38)	
	Refrigerant oil brand		IDEMITSUKOSAN CO., LTD		
	Refrigerant oil type		FV50S	FV50S	
	Refrigerant oil charge	ml	(1700+1700+2000)*2+(2300+2300+2000)		
Outdoor fan motor	Brand		Match-Well	Match-Well	
	Model		MWS386-8K	MWS386-8K	
	Voltage		DC339	DC339	
	IP class		IP44	IP44	
	Type/quantity		DC/6	DC/6	
	Insulation class		E	E	
	Safe class		I	I	
	Power input	W	(471*2)*2+(471*2)	(471*2)*2+(471*2)	
	Output	W	(386*2)*2+(386*2)	(386*2)*2+(386*2)	
	Rated current	A	(25*2)*2+(25*2)	(25*2)*2+(25*2)	
	Capacitor	μF	/	/	
	Speed	rpm	(200~1140)*2+(200~1180)	(200~1140)*2+(200~1180)	
Outdoor fan	Brand		MHI	MHI	
	Model		/	/	
	Material		AS+20%GF	AS+20%GF	
	Type		Axial	Axial	
	Diameter	mm	Φ570×6	Φ570×6	
	Height	mm	202×6	202×6	

Model		AW-YDV1250HT-H16	AW-YDV1304HT-H16	
Outdoor coil	Number of rows		6	
	Tube pitch (a)×row pitch (b)	mm	25.4×19.05	
	Fin spacing	mm	1.3	
	Fin type (code)		Hydrophilic aluminum	
	Fin coating type	Optional	Clear lacquer	Clear lacquer
	Salt spray test duration	Hour	168	168
	Tube outside dia. and type	mm	INNERGROOVE TUBE Φ8	
	Coil length×height	mm	((1648.2×812.8)*2)+((1648.2×1168.4+1648.2×812)*2)	
	Number of circuits		(10*2)*2+(15*2)	(10*2)*2+(15*2)
Cabinet coating	Coating type		Powder Coating	
	Salt spray test duration	Hour	72	
	Sheet metal material		Hot zinc plate	
	Sheet metal thickness	mm	0.8	
Control panel enclosure IP class		Standard	IP24	
Outdoor air flow (cooling/heating)		m ³ /h	47400 / 43800	
External static pressure		Pa	82	
Outdoor sound level (sound pressure level) (H)		dB (A)	63	
Outdoor sound level (sound power level) (H)		dB (A)	81	
Outdoor unit	Dimension (W*D*H)	mm	1350×720×2048+(1350×720×1690)*2	
	Packing (W*D*H)	mm	1450×826×2225+(1450×826×1885)*2	
	Net weight	kg	1001	
	Gross weight	kg	1076	
Refrigerant	Type		R410A	
	Charged volume	kg	30	
Throttle type			EXV	
Design pressure		MPa	4.15	
Refrigerant piping	Liquid pipe	mm	19.05	
	Gas pipe	mm	38.1	
	Oil pipe	mm	9.52	
	Total pipe length	m	1000	
	Max. pipe length (Equivalent / actual)	m	190/165	
	Max. Diff. indoor/outdoor unit*1		90 (Outdoor higher than indoor) 110 (Indoor higher than outdoor)	
	Standard Diff. indoor/outdoor unit	m	50 (Outdoor higher than indoor) 40 (Indoor higher than outdoor)	
	Max. / standard Diff. indoor/indoor unit*1	m	30 / 18	
Connectable indoor unit ratio		%	50~130	
Maximum indoor units		Piece	64	
Connection wiring	Max. fuse current	A	200	
	Min. wiring current	A	141	
	Power wiring	mm ²	/	
	Signal wiring	mm ²	2	
Operation range		°C	Cooling: -5~52 Heating: -23~18	
Norminal condition: indoor temperature (cooling): 27DB (°C)/19WB (°C), indoor temperature (heating): 20DB (°C)/14.5WB (°C). Outdoor temperature (cooling): 35DB (°C)/24WB (°C), outdoor temperature (heating): 7DB (°C)/6WB (°C) The data is measured with 7.5m equivalent pipe and 0m height difference. The noise level will be measured in the third octave band limited values in the semi-anechoic chamber, using a Real Time Analyser calibrated sound intensity meter. It is a sound pressure noise level. *1 If the height difference between the outdoor and indoor units is from 50 to 110m or the height difference between the indoor units is from 18 to 30m, you Must contact your local distributor/dealer for individual design and production.				

Model		AW-YDV1354HT-H16		AW-YDV1408HT-H16	
Combination		14+16+18		14+18+18	
Power supply		Ph/V/Hz	3/380~400/50/60		3/380~400/50/60
Cooling (T1)	Rated capacity	kW	135.4		140.8
	Rated capacity	kBtu/h	4620		480.4
	Rated power input	kW	35.13		36.72
	Max. power input	kW	91.9		94.84
	EER		3.85		3.83
	Rated current	A	59.31		61.99
	Max. current	A	147.93		150
Cooling (T3)	Rated capacity	kW	115.2		118.4
	Rated power input	kW	39.96		41.95
	Rated current	A	67.46		70.82
Heating	Rated capacity	kW	153.5		162
	Rated capacity	kBtu/h	523.74		55274
	Rated power input	kW	36.57		38.67
	Max. power input	kW	68.7		70.1
	COP		4.20		4.19
	Rated current	A	77.15		80.70
	Max. current	A	87.49		91.79
	Capacity at low temperature	kW	123.2		125.4
Compressor	Brand	MITSUBISHI ELECTRIC			
	Model	ANB42F*2+ANB66F*2+ANB66F*2		ANB42F*2+ANB66F*2+ANB66F*2	
	Type	DC INV. SCROLL		DC INV. SCROLL	
	Compressor quantity	6		6	
	Capacity	W	(13900+13900)+(22000+22000)*2		(13900+13900)+(22000+22000)*2
	Power input	W	(4160+4160)+(6500+6500)*2		(4160+4160)+(6500+6500)*2
	Rated current (RLA)	A	(15.2+15.2)+(18.5+18.5)+(18.5+18.5)		(15.2+15.2)+(18.5+18.5)*2
	Speed	rps	60		60
	Crankcase heater	W	(38+38)+(38+38)+(38+38)		(38+38)+(38+38)*2
	Refrigerant oil brand	IDEMITSUKOSAN CO., LTD			
	Refrigerant oil type	FV50S		FV50S	
	Refrigerant oil charge	ml	(1700+1700+2000)+(2300+2300+2000)+(2300+2300+2000)		(1700+1700+2000)+(2300+2300+2000)*2
Outdoor fan motor	Brand	Match-Well		Match-Well	
	Model	MWS386-8K		MWS386-8K	
	Voltage	DC339		DC339	
	IP class	IP44		IP44	
	Type/quantity	DC/6		DC/6	
	Insulation class	E		E	
	Safe class	I		I	
	Power input	W	(471*2)+(471*2)+(471*2)		(471*2)+(471*2)*2
	Output	W	(386*2)+(386*2)+(386*2)		(386*2)+(386*2)*2
	Rated current	A	(25*2)+(25*2)+(25*2)		(25*2)+(25*2)*2
	Capacitor	μF	/		/
	Speed	rpm	(200~1140)+(200~1180)+(200~1180)		(200~1140)+(200~1180)*2
Outdoor fan	Brand	MHI		MHI	
	Model	/		/	
	Material	AS+20%GF		AS+20%GF	
	Type	Axial		Axial	
	Diameter	mm	Φ570×6		Φ570×6
	Height	mm	202×6		202×6

Model		AW-YDV1354HT-H16	AW-YDV1408HT-H16	
Outdoor coil	Number of rows		6	
	Tube pitch (a)×row pitch (b)	mm	25.4×19.05	
	Fin spacing	mm	1.3	
	Fin type (code)		Hydrophilic aluminum	
	Fin coating type	Optional	Clear lacquer	
	Salt spray test duration	Hour	168	
	Tube outside dia. and type		INNERGROOVE TUBE	
		mm	φ8	φ8
	Coil length×height	mm	((1648.2×812.8)*2)+ ((1648.2×1168.4+1648.2×812)*2)+ ((1648.2×1168.4+1648.2×812)*2)	((1648.2×812.8)*2)+ ((1648.2×1168.4+1648.2×812)*2)*2
Number of circuits		(10*2)+(15*2)+(15*2)	(10*2)+(15*2)*2	
Cabinet coating	Coating type		Powder Coating	
	Salt spray test duration	Hour	72	
	Sheet metal material		Hot zinc plate	
	Sheet metal thickness	mm	0.8	
Control panel enclosure IP class		Standard	IP24	
Outdoor air flow (cooling/heating)		m ³ /h	48000 / 44400	
External static pressure		Pa	82	
Outdoor sound level (sound pressure level) (H)		dB (A)	64	
Outdoor sound level (sound power level) (H)		dB (A)	82	
Outdoor unit	Dimension (W*D*H)	mm	(1350×720×2048)*2+1350×720×1690	
	Packing (W*D*H)	mm	1450×826×1885+(1450×826×2225)*2	
	Net weight	kg	1039	
	Gross weight	kg	1114	
Refrigerant	Type		R410A	
	Charged volume	kg	30	
Throttle type			EXV	
Design pressure		MPa	4.15	
Refrigerant piping	Liquid pipe	mm	19.05	
	Gas pipe	mm	41.3	
	Oil pipe	mm	9.52	
	Total pipe length	m	1000	
	Max. pipe length (Equivalent / actual)	m	190/165	
	Max. Diff. indoor/outdoor unit*1		90 (Outdoor higher than indoor) 110 (Indoor higher than outdoor)	
	Standard Diff. indoor/outdoor unit	m	50 (Outdoor higher than indoor) 40 (Indoor higher than outdoor)	
	Max. / standard Diff. indoor/indoor unit*1	m	30 / 18	
Connectable indoor unit ratio		%	50~130	
Maximum indoor units		Piece	64	
Connection wiring	Max. fuse current	A	220	
	Min. wiring current	A	165.9	
	Power wiring	mm ²	/	
	Signal wiring	mm ²	2	
Operation range		°C	Cooling: -5~52 Heating: -23~18	
<p>Normal condition: indoor temperature (cooling): 27DB (°C)/19WB (°C), indoor temperature (heating): 20DB (°C)/14.5WB (°C). Outdoor temperature (cooling): 35DB (°C)/24WB (°C), outdoor temperature (heating): 7DB (°C)/6WB (°C) The data is measured with 7.5m equivalent pipe and 0m height difference.</p> <p>The noise level will be measured in the third octave band limited values in the semi-anechoic chamber, using a Real Time Analyser calibrated sound intensity meter. It is a sound pressure noise level.</p> <p>*1 If the height difference between the outdoor and indoor units is from 50 to 110m or the height difference between the indoor units is from 18 to 30m, you Must contact your local distributor/dealer for individual design and production.</p>				

Model		AW-YDV1460HT-H16		AW-YDV1512HT-H16	
Combination			16+18+18	18+18+18	
Power supply		Ph/V/Hz	3/380~400/50/60		3/380~400/50/60
Cooling (T1)	Rated capacity	kW	145.8	151.2	
	Rated capacity	kBtu/h	497.5	515.9	
	Rated power input	kW	38.16	39.75	
	Max. power input	kW	10278	105.72	
	EER		3.82	3.80	
	Rated current	A	64.42	67.11	
	Max. current	A	167.73	169.8	
Cooling (T3)	Rated capacity	kW	125.2	128.4	
	Rated power input	kW	43.76	45.75	
	Rated current	A	73.88	77.24	
Heating	Rated capacity	kW	167	175.5	
	Rated capacity	kBtu/h	569.80	598.81	
	Rated power input	kW	40.05	4215	
	Max. power input	kW	74.2	75.6	
	COP		4.17	4.16	
	Rated current	A	67.61	71.16	
	Max. current	A	12260	126.90	
	Capacity at low temperature	kW	128.9	131.1	
Compressor	Brand		MITSUBISHI ELECTRIC		
	Model		ANB66F*2+ANB66F*2+ANB66F*2	ANB66F*2+ANB66F*2+ANB66F*2	
	Type		DC INV. SCROLL	DC INV. SCROLL	
	Compressor quantity		6	6	
	Capacity	W	(22000+22000)*3	(22000+22000)*3	
	Power input	W	(6500+6500)*3	(6500+6500)*3	
	Rated current (RLA)	A	(18.5+18.5)+(18.5+18.5)*2	(18.5+18.5)*3	
	Speed	rps	60	60	
	Crankcase heater	W	(38+38)+(38+38)*2	(38+38)*3	
	Refrigerant oil brand		IDEMITSUKOSAN CO., LTD		
	Refrigerant oil type		FV50S	FV50S	
	Refrigerant oil charge	ml	(2300+2300+2000)+(2300+2300+2000)*2	(2300+2300+2000)*3	
Outdoor fan motor	Brand		Match-Well	Match-Well	
	Model		MWS386-8K	MWS386-8K	
	Voltage		DC339	DC339	
	IP class		IP44	IP44	
	Type/quantity		DC/6	DC/6	
	Insulation class		E	E	
	Safe class		I	I	
	Power input	W	(471*2)+(471*2)*2	(471*2)*3	
	Output	W	(386*2)+(386*2)*2	(386*2)*3	
	Rated current	A	(25*2)+(25*2)*2	(25*2)*3	
	Capacitor	μF	/	/	
	Speed	rpm	(200~1180)+(200~1180)*2	(200~1180)*3	
	Outdoor fan	Brand		MHI	MHI
Model			/	/	
Material			AS+20%GF	AS+20%GF	
Type			Axial	Axial	
Diameter		mm	Φ570×6	Φ570×6	
Height		mm	202×6	202×6	

Model		AW-YDV1460HT-H16	AW-YDV1512HT-H16	
Outdoor coil	Number of rows		6	
	Tube pitch (a)×row pitch (b)	mm	25.4×19.05	
	Fin spacing	mm	1.3	
	Fin type (code)		Hydrophilic aluminum	
	Fin coating type	Optional	Clear lacquer	Clear lacquer
	Salt spray test duration	Hour	168	168
	Tube outside dia. and type	mm	INNERGROOVE TUBE	
			Φ8	Φ8
	Coil length×height	mm	$((1648.2 \times 1168.4 + 1648.2 \times 812) \times 2) + ((1648.2 \times 1168.4 + 1648.2 \times 812) \times 2) \times 2$	$((1648.2 \times 1168.4 + 1648.2 \times 812) \times 2) \times 3$
Number of circuits		$(15 \times 2) + (15 \times 2) \times 2$	$(15 \times 2) \times 3$	
Cabinet coating	Coating type		Powder Coating	Powder Coating
	Salt spray test duration	Hour	72	72
	Sheet metal material		Hot zinc plate	Hot zinc plate
	Sheet metal thickness	mm	0.8	0.8
Control panel enclosure IP class		Standard	IP24	IP24
Outdoor air flow (cooling/heating)		m ³ /h	48600 / 45000	48600 / 45000
External static pressure		Pa	82	82
Outdoor sound level (sound pressure level) (H)		dB (A)	64.5	65
Outdoor sound level (sound power level) (H)		dB (A)	83	83
Outdoor unit	Dimension (W*D*H)	mm	$(1350 \times 720 \times 2048) \times 3$	$(1350 \times 720 \times 2048) \times 3$
	Packing (W*D*H)	mm	$(1450 \times 826 \times 2225) \times 3$	$(1450 \times 826 \times 2225) \times 3$
	Net weight	kg	1077	1077
	Gross weight	kg	1152	1152
Refrigerant	Type		R410A	R410A
	Charged volume	kg	30	30
Throttle type			EXV	EXV
Design pressure		MPa	4.15	4.15
Refrigerant piping	Liquid pipe	mm	19.05	19.05
	Gas pipe	mm	41.3	41.3
	Oil pipe	mm	9.52	9.52
	Total pipe length	m	1000	1000
	Max. pipe length (Equivalent / actual)	m	190/165	190/165
	Max. Diff. indoor/outdoor unit*1		90 (Outdoor higher than indoor) 110 (Indoor higher than outdoor)	
	Standard Diff. indoor/outdoor unit	m	50 (Outdoor higher than indoor) 40 (Indoor higher than outdoor)	
Max. / standard Diff. indoor/indoor unit*1	m	30 / 18	30 / 18	
Connectable indoor unit ratio		%	50~130	50~130
Maximum indoor units		Piece	64	64
Connection wiring	Max. fuse current	A	240	240
	Min. wiring current	A	190.8	190.8
	Power wiring	mm ²	/	/
	Signal wiring	mm ²	2	
Operation range		°C	Cooling: -5~52 Heating: -23~18	
Norminal condition: indoor temperature (cooling): 27DB (°C)/19WB (°C), indoor temperature (heating): 20DB (°C)/14.5WB (°C). Outdoor temperature (cooling): 35DB (°C)/24WB (°C), outdoor temperature (heating): 7DB (°C)/6WB (°C) The data is measured with 7.5m equivalent pipe and 0m height difference. The noise level will be measured in the third octave band limited values in the semi-anechoic chamber, using a Real Time Analyser calibrated sound intensity meter. It is a sound pressure noise level. *1 If the height difference between the outdoor and indoor units is from 50 to 110m or the height difference between the indoor units is from 18 to 30m, you Must contact your local distributor/dealer for individual design and production.				

Model		AW-YDV1570HT-H16	AW-YDV1624HT-H16
Combination		18+18+20	18+20+20
Power supply		Ph/V/Hz	3/380~400/50/60
Cooling (T1)	Rated capacity	kW	156.8
	Rated capacity	kBtu/h	535.0
	Rated power input	kW	41.7
	Max. power input	kW	107.95
	EER		3.76
	Rated current	A	70.40
	Max. current	A	173.7
Cooling (T3)	Rated capacity	kW	130.4
	Rated power input	kW	47.46
	Rated current	A	80.12
Heating	Rated capacity	kW	180
	Rated capacity	kBtu/h	614.16
	Rated power input	kW	43.5
	Max. power input	kW	79.02
	COP		4.14
	Rated current	A	73.44
	Max. current	A	13200
	Capacity at low temperature	kW	136.1
Compressor	Brand	MITSUBISHI ELECTRIC	
	Model	ANB66F*2+ANB66F*2+ANB66F*2	ANB66F*2+ANB66F*2+ANB66F*2
	Type	DC INV. SCROLL	
	Compressor quantity	6	
	Capacity	W	(22000+22000)*3
	Power input	W	(6500+6500)*3
	Rated current (RLA)	A	(18.5+18.5)*2+(18.5+18.5)
	Speed	rps	60
	Crankcase heater	W	(38+38)*2+(38+38)
	Refrigerant oil brand	IDEMITSUKOSAN CO., LTD	
	Refrigerant oil type	FV50S	
	Refrigerant oil charge	ml	(2300+2300+2000)*2+(2300+2300+2000)
Outdoor fan motor	Brand	Match-Well	
	Model	MWS386-8K	
	Voltage	DC339	
	IP class	IP44	
	Type/quantity	DC/6	
	Insulation class	E	
	Safe class	I	
	Power input	W	(471*2)*2+(471*2)
	Output	W	(386*2)*2+(386*2)
	Rated current	A	(25*2)*2+(25*2)
	Capacitor	μF	/
	Speed	rpm	(200~1180)*2+(200~1180)
Outdoor fan	Brand	MHI	
	Model	/	
	Material	AS+20%GF	
	Type	Axial	
	Diameter	mm	Φ570×6
	Height	mm	202×6

Model			AW-YDV1570HT-H16	AW-YDV1624HT-H16
Outdoor coil	Number of rows		6	6
	Tube pitch (a)×row pitch (b)	mm	25.4×19.05	25.4×19.05
	Fin spacing	mm	1.3	1.3
	Fin type (code)		Hydrophilic aluminum	
	Fin coating type	Optional	Clear lacquer	Clear lacquer
	Salt spray test duration	Hour	168	168
	Tube outside dia. and type		INNERGROOVE TUBE	
		mm	Φ8	Φ8
	Coil length×height	mm	$((1648.2 \times 1168.4 + 1648.2 \times 812) \times 2) \times 2 + ((1648.2 \times 1168.4 + 1648.2 \times 812) \times 2) + 48.2 \times 1168.4 + 1648.2 \times 812) \times 2$	$((1648.2 \times 1168.4 + 1648.2 \times 812) \times 2) + ((1648.2 \times 1168.4 + 1648.2 \times 812) \times 2) \times 2$
Number of circuits		$(15 \times 2) \times 2 + (15 \times 2)$	$(15 \times 2) + (15 \times 2) \times 2$	
Cabinet coating	Coating type		Powder Coating	Powder Coating
	Salt spray test duration	Hour	72	72
	Sheet metal material		Hot zinc plate	Hot zinc plate
	Sheet metal thickness	mm	0.8	0.8
Control panel enclosure IP class		Standard	IP24	IP24
Outdoor air flow (cooling/heating)		m ³ /h	48600 / 45000	48600 / 45000
External static pressure		Pa	82	82
Outdoor sound level (sound pressure level) (H)		dB (A)	65	65.5
Outdoor sound level (sound power level) (H)		dB (A)	83	84
Outdoor unit	Dimension (W*D*H)	mm	$(1350 \times 720 \times 2048) \times 3$	$(1350 \times 720 \times 2048) \times 3$
	Packing (W*D*H)	mm	$(1450 \times 826 \times 2225) \times 3$	$(1450 \times 826 \times 2225) \times 3$
	Net weight	kg	1077	1077
	Gross weight	kg	1152	1152
Refrigerant	Type		R410A	R410A
	Charged volume	kg	30	30
Throttle type			EXV	EXV
Design pressure		MPa	4.15	4.15
Refrigerant piping	Liquid pipe	mm	22.22	22.22
	Gas pipe	mm	44.5	44.5
	Oil pipe	mm	9.52	9.52
	Total pipe length	m	1000	1000
	Max. pipe length (Equivalent / actual)	m	190/165	190/165
	Max. Diff. indoor/outdoor unit*1		90 (Outdoor higher than indoor) 110 (Indoor higher than outdoor)	
	Standard Diff. indoor/outdoor unit	m	50 (Outdoor higher than indoor) 40 (Indoor higher than outdoor)	
Max. / standard Diff. indoor/indoor unit*1	m	30 / 18	30 / 18	
Connectable indoor unit ratio		%	50~130	50~130
Maximum indoor units		Piece	64	64
Connection wiring	Max. fuse current	A	240	240
	Min. wiring current	A	190.8	190.8
	Power wiring	mm ²	/	/
	Signal wiring	mm ²	2	
Operation range		°C	Cooling: -5~52 Heating: -23~18	
<p>Norminal condition: indoor temperature (cooling): 27DB (°C)/19WB (°C), indoor temperature (heating): 20DB (°C)/14.5WB (°C). Outdoor temperature (cooling): 35DB (°C)/24WB (°C), outdoor temperature (heating): 7DB (°C)/6WB (°C) The data is measured with 7.5m equivalent pipe and 0m height difference.</p> <p>The noise level will be measured in the third octave band limited values in the semi-anechoic chamber, using a Real Time Analyser calibrated sound intensity meter. It is a sound pressure noise level.</p> <p>*1 If the height difference between the outdoor and indoor units is from 50 to 110m or the height difference between the indoor units is from 18 to 30m, you Must contact your local distributor/dealer for individual design and production.</p>				

Model		AW-YDV1680HT-H16	
Combination		20+20+20	
Power supply		Ph/V/Hz	3/380~400/50/60
Cooling (T1)	Rated capacity	kW	168
	Rated capacity	kBtu/h	573.2
	Rated power input	kW	45.6
	Max. power input	kW	11241
	EER		3.68
	Rated current	A	76.98
	Max. current	A	181.5
Cooling (T3)	Rated capacity	kW	134.4
	Rated power input	kW	50.88
	Rated current	A	85.90
Heating	Rated capacity	kW	189
	Rated capacity	kBtu/h	644.87
	Rated power input	kW	46.2
	Max. power input	kW	85.86
	COP		4.09
	Rated current	A	78.00
	Max. current	A	14220
	Capacity at low temperature	kW	146.1
Compressor	Brand	MITSUBISHI ELECTRIC	
	Model	ANB66F*2+ANB66F*2+ANB66F*2	
	Type	DC INV. SCROLL	
	Compressor quantity	6	
	Capacity	W	(22000+22000)*3
	Power input	W	(6500+6500)*3
	Rated current (RLA)	A	(18.5+18.5)*3
	Speed	rps	60
	Crankcase heater	W	(38+38)*3
	Refrigerant oil brand	IDEMITSUKOSAN CO., LTD	
	Refrigerant oil type	FV50S	
	Refrigerant oil charge	ml	(2300+2300+2000)*3
Outdoor fan motor	Brand	Match-Well	
	Model	MWS386-8K	
	Voltage	DC339	
	IP class	IP44	
	Type/quantity	DC/6	
	Insulation class	E	
	Safe class	I	
	Power input	W	(471*2)*3
	Output	W	(386*2)*3
	Rated current	A	(25*2)*3
	Capacitor	μF	/
	Speed	rpm	(200~1180)*3
	Outdoor fan	Brand	MHI
Model		/	
Material		AS+20%GF	
Type		Axial	
Diameter		mm	Φ570×6
Height		mm	202×6

Model		AW-YDV1680HT-H16	
Outdoor coil	Number of rows		6
	Tube pitch (a)×row pitch (b)	mm	25.4×19.05
	Fin spacing	mm	1.3
	Fin type (code)		Hydrophilic aluminum
	Fin coating type	Optional	Clear lacquer
	Salt spray test duration	Hour	168
	Tube outside dia. and type		INNERGROOVE TUBE
		mm	Φ8
	Coil length×height	mm	((1648.2×1168.4+1648.2×812)*2)*3
Number of circuits		(15*2)*3	
Cabinet coating	Coating type		Powder Coating
	Salt spray test duration	Hour	72
	Sheet metal material		Hot zinc plate
	Sheet metal thickness	mm	0.8
Control panel enclosure IP class		Standard	IP24
Outdoor air flow (cooling/heating)		m ³ /h	48600 / 45000
External static pressure		Pa	82
Outdoor sound level (sound pressure level) (H)		dB (A)	66
Outdoor sound level (sound power level) (H)		dB (A)	84
Outdoor unit	Dimension (W*D*H)	mm	(1350×720×2048)*3
	Packing (W*D*H)	mm	(1450×826×2225)*3
	Net weight	kg	1077
	Gross weight	kg	1152
Refrigerant	Type		R410A
	Charged volume	kg	30
Throttle type			EXV
Design pressure		MPa	4.15
Refrigerant piping	Liquid pipe	mm	22.22
	Gas pipe	mm	44.5
	Oil pipe	mm	9.52
	Total pipe length	m	1000
	Max. pipe length (Equivalent / actual)	m	190/165
	Max. Diff. indoor/outdoor unit*1		90 (Outdoor higher than indoor) 110 (Indoor higher than outdoor)
	Standard Diff. indoor/outdoor unit	m	50 (Outdoor higher than indoor) 40 (Indoor higher than outdoor)
	Max. / standard Diff. indoor/indoor unit*1	m	30 / 18
Connectable indoor unit ratio		%	50~130
Maximum indoor units		Piece	64
Connection wiring	Max. fuse current	A	240
	Min. wiring current	A	190.8
	Power wiring	mm ²	/
	Signal wiring	mm ²	2
Operation range		°C	Cooling: -5~52 Heating: -23~18
Norminal condition: indoor temperature (cooling): 27DB (°C)/19WB (°C), indoor temperature (heating): 20DB (°C)/14.5WB (°C). Outdoor temperature (cooling): 35DB (°C)/24WB (°C), outdoor temperature (heating): 7DB (°C)/6WB (°C) The data is measured with 7.5m equivalent pipe and 0m height difference. The noise level will be measured in the third octave band limited values in the semi-anechoic chamber, using a Real Time Analyser calibrated sound intensity meter. It is a sound pressure noise level. *1 If the height difference between the outdoor and indoor units is from 50 to 110m or the height difference between the indoor units is from 18 to 30m, you Must contact your local distributor/dealer for individual design and production.			

3. Dimension

AW-YDV250HT-H16 AW-YDV280HT-H16 AW-YDV335HT-H16 AW-YDV400HT-H16

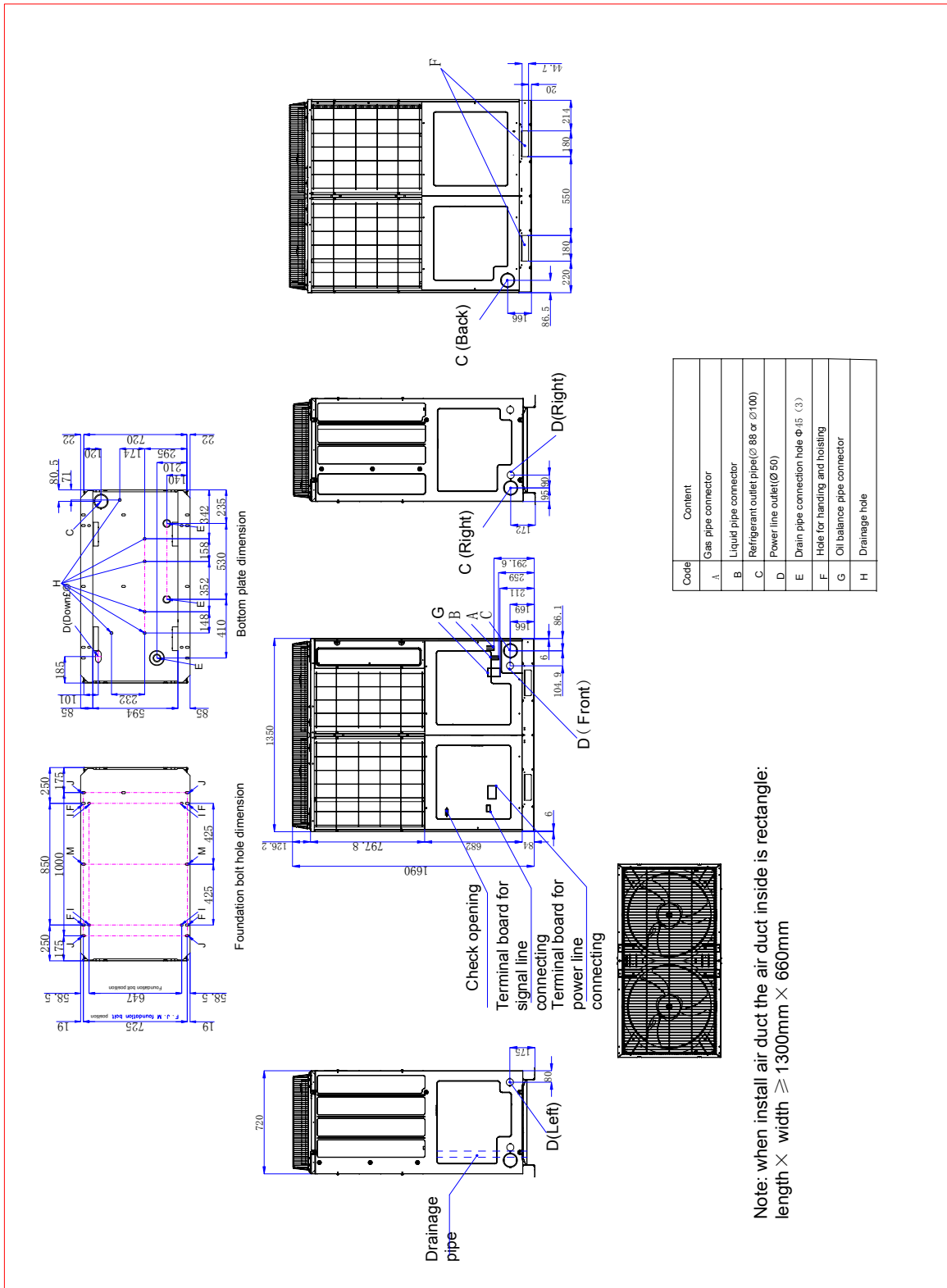

AW-YDV450HT-H16 AW-YDV504HT-H16 AW-YDV560HT-H16

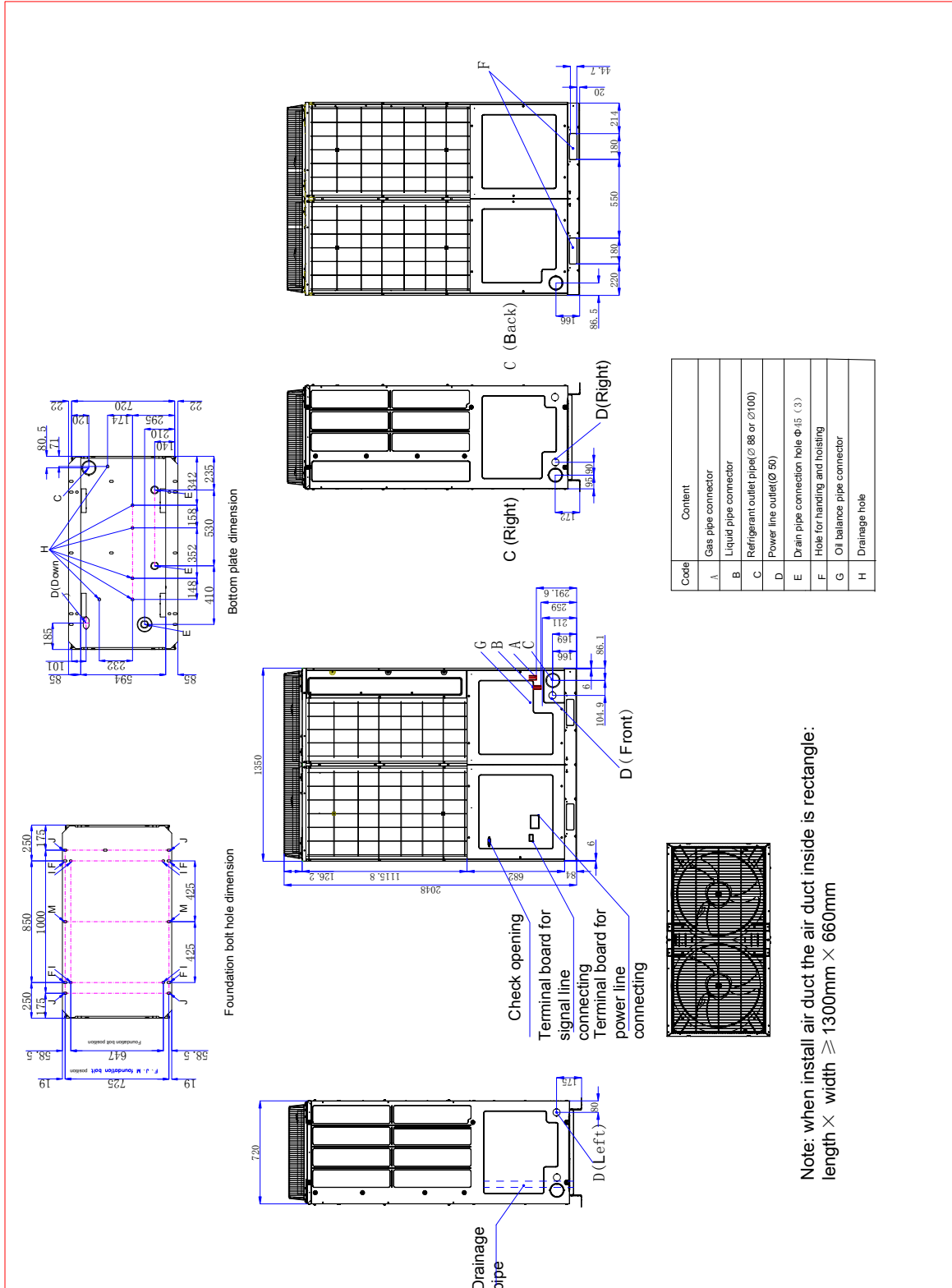

4. Piping Diagram

AW-YDV250HT-H16 AW-YDV280HT-H16 AW-YDV335HT-H16

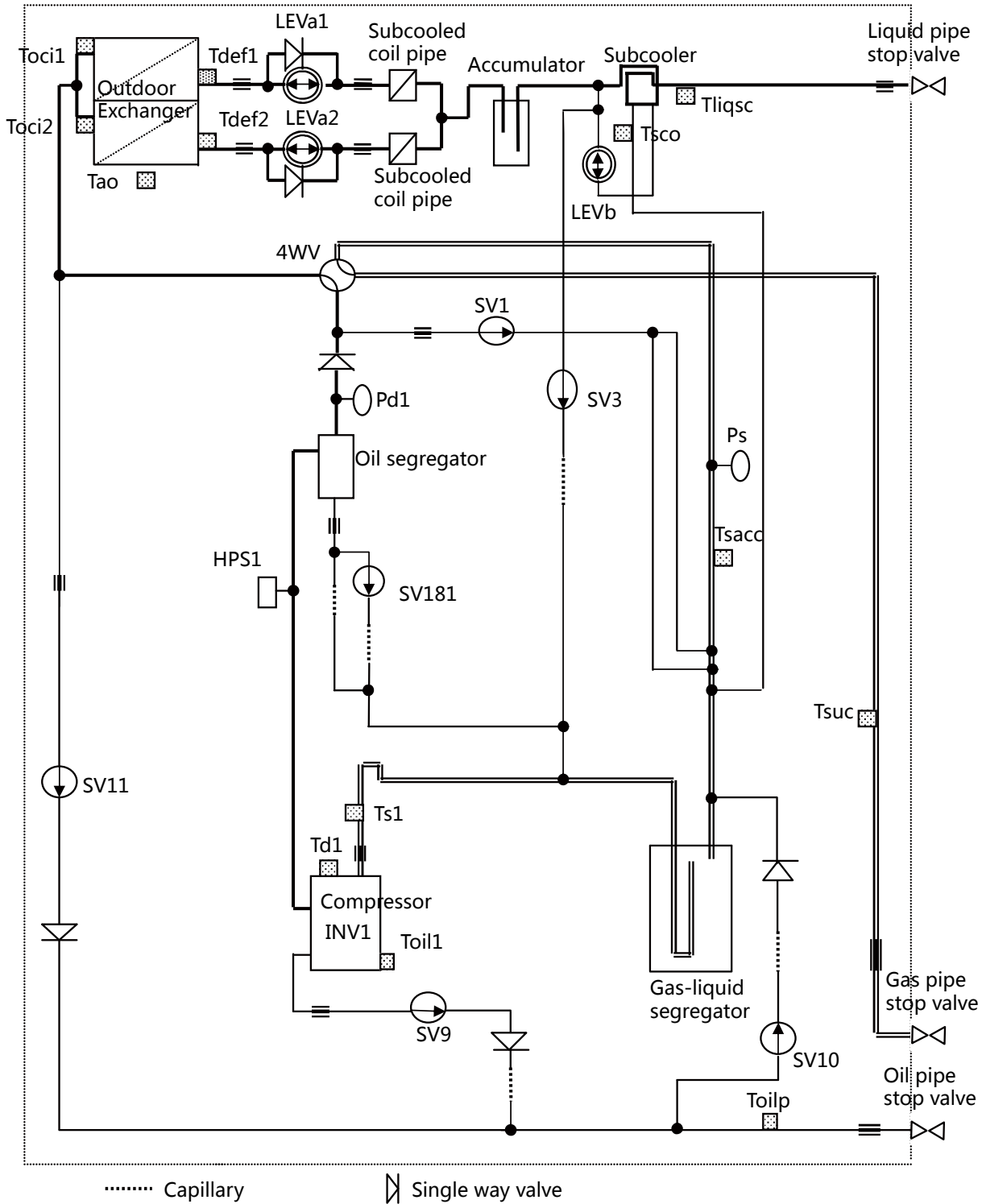

AW-YDV400HT-H16 AW-YDV450HT-H16 AW-YDV504HT-H16 AW-YDV560HT-H16

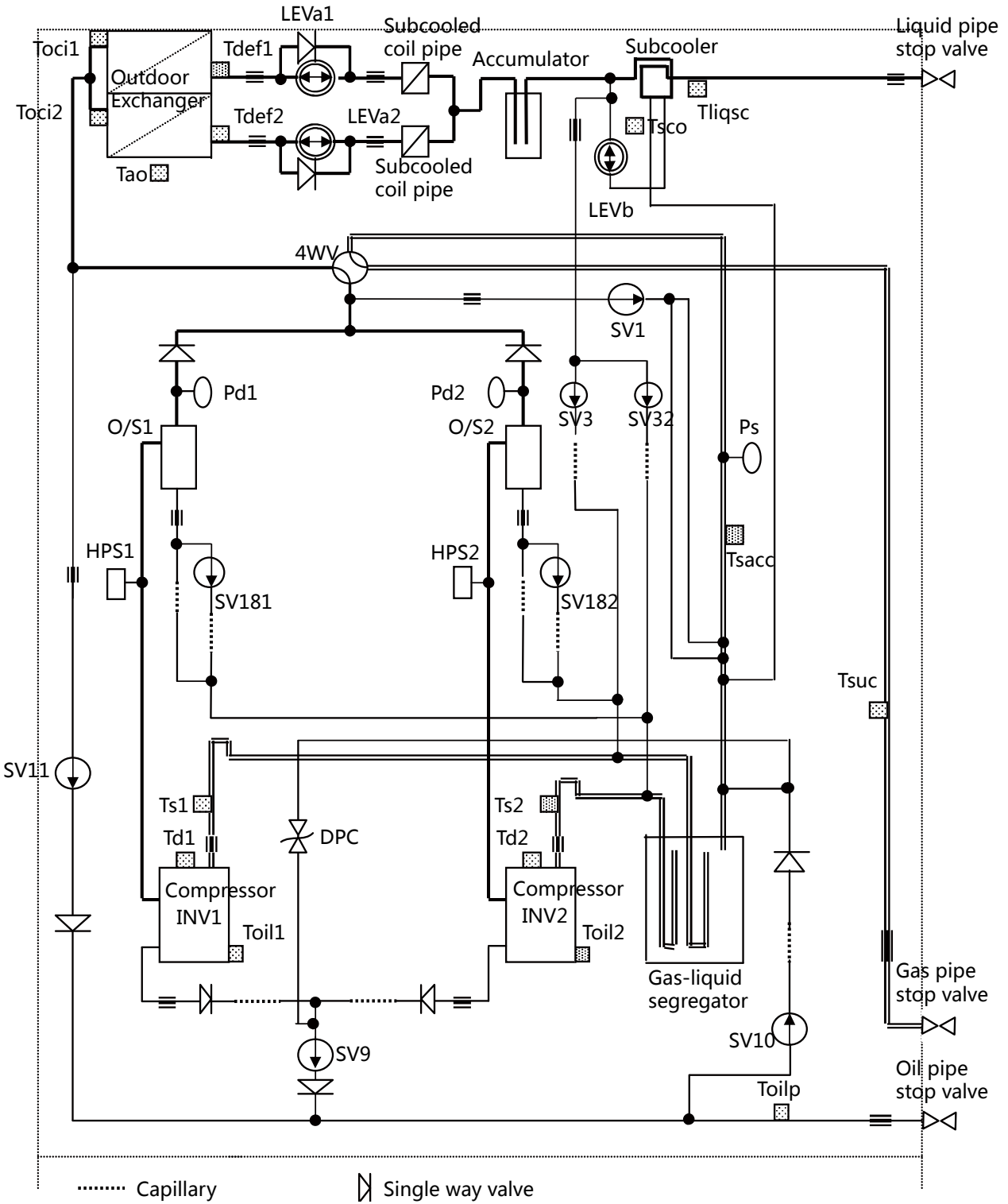

Part name	Sign	Function	Data	Remark
Compressor	/	Capacity control, to meet indoor load through frequency adjustment.	ANB42: 0.302Ω	20℃
			ANB52: 0.302Ω	
			ANB66: 0.23Ω	
Pressure switch	HPs1/2	Protection control for high pressure	4.15Mpa, OFF setting	
Pressure sensor	Pd1/Pd2	In heating , compressor frequency adjustment and protection control for abnormal pressure	0~4.15MPa	
	Ps	In cooling , compressor frequency adjustment and protection control for abnormal pressure	0~1.7MPa	
Electronic expansion valve	LEVa1, 2	Refrigerant flow control in heating	HAM-BD30SM-2	
	LEVb	According to the liquid pipe super-cooled degree control in cooling	HAM-B50YGSM-1	
Solenoid valve	SV1	1. Balance between high and low pressures when the compressor starts and stops; 2. Protection to prevent high and low pressures.	AC220V	2A
	SV181/ SV182	Auxiliary oil return capillary to return oil when the compressor operates under high frequency.	AC220V	2A
	SV3/SV32	Started when the compressor discharging temperature and oil temperature are too high to carry out temperature reduction by refrigerant spraying.	AC220V	2A
	SV10	Outdoor unit SV10 for oil suction starts during oil balance; for pressure relief to prevent explosion of pipe group.	AC220V	2A
	SV11	The stopped outdoor unit starts during heating to realize gas balance of the low pressure side together with the operating outdoor unit to prevent liquid return.	AC220V	2A
	SV9	The outdoor unit for oil discharging starts SV9 for oil balancing during oil balance among modules.	AC220V	2A
Unloading valve	DPC	Automatically open when the detection pressure is too high		
Four-way valve	4WV	Switch between cooling and heating	AC220V Power on during heating and power off during cooling or defrosting.	
Temperature sensor	Toil1/2	To detect the temperature of refrigeration lubricant at the compressor bottom.	R (80℃) = 50K B (25/80℃)=4450K	
	Tsuc	To detect the temperature of gas return pipe so as to judge whether the switch of four-way valve succeeds.		
	Tsacc	To detect the inlet temperature of gas-liquied seperator		
	Td1/Td2	To detect the top temperature of inverter/ON-OFF compressor.		
	Toilp	To detect oil pipe temperature during oil balancing.	R(25℃)=10K, B(25℃ /50℃) =3700 K	
	Tdef1/Tdef2	To detect the frosting of outdoor heat exchanger.		
	Ts1/Ts2	To detect the suction temperature of compressor.		
	Tsco	To detect the temperature of regenerator outlet pipe to control LEVb during cooling.		
	Toci1/2	To detect the temperature of condenser main gas pipe to control LEVa1, 2 during heating.		
	Tao	To detect ambient temperature and control the initial air speed and defrosting conditions.		
Tliqsc	To detect the temperature of regenerator main outlet pipe to control LEVb during cooling.			
Heater	CHa	Used to heat the liquid refrigerant in the gas-liquid separator.	40W, 220V	
	CH1/2	Used to heat the compressor oil in the inverter compressor.	33W, 220V, 2 pieces/compressor	

5. Wiring Diagram

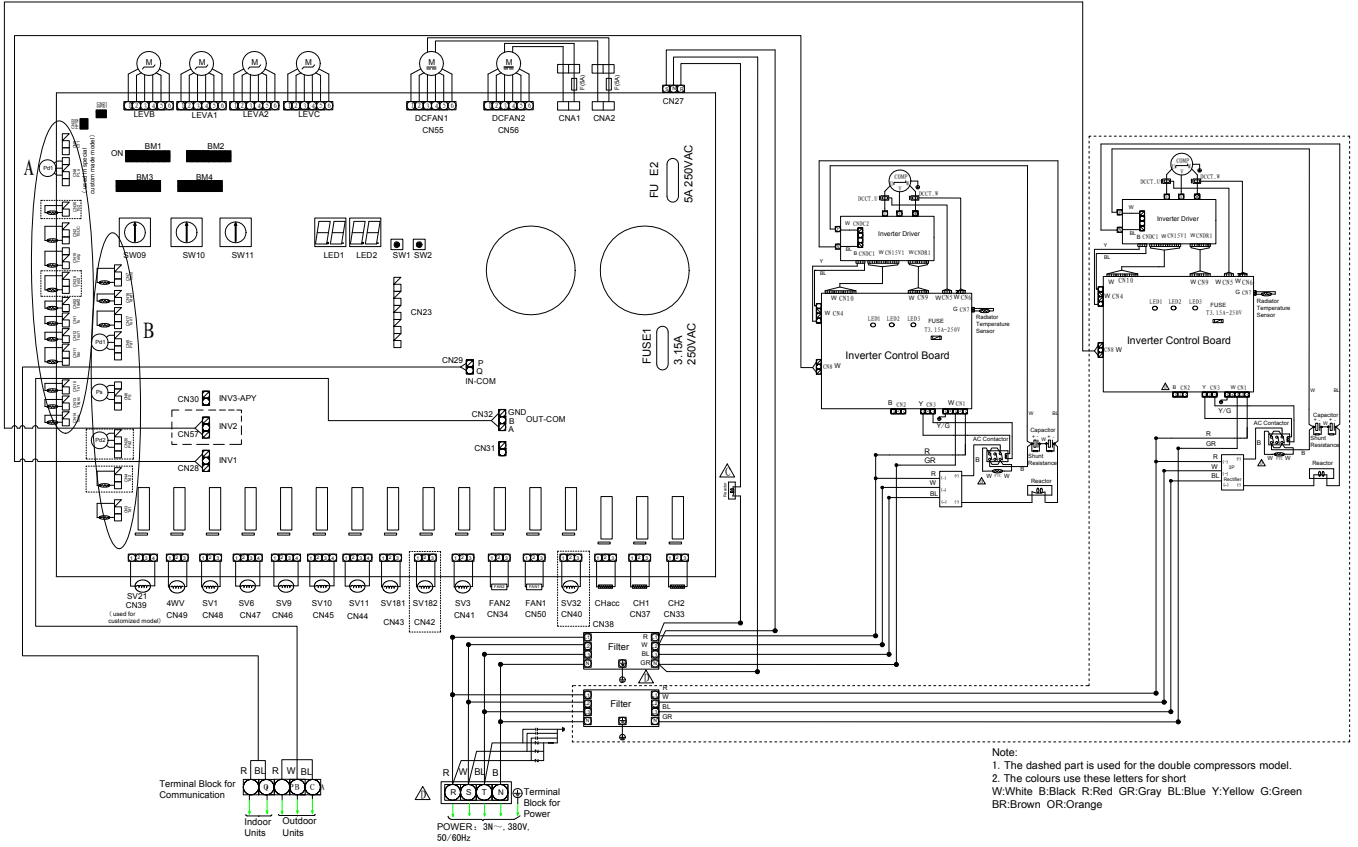

Symbol definition

Sensor	Terminal	Description	Sensor	Terminal	Description	Sensor	Terminal	Description
Ts00	CN14	Detect SH temp. during sub-cooler control	Tdef2	CN52	Detect the defrosting temp.	Td2	CN4	Detect discharging temp. of INV compressor
Tlipic	CN13	Detect liquid pipe temp. SH during sub-cooler control	TSUC	CN2	Detect the outdoor gas pipe temp.	Pd2	CN20	High pressure sensor
Ts1	CN10	Detect suction temp. of INV compressor	TS2	CN35	Detect suction temp. of INV compressor	Pd1	CN5	High pressure sensor
Tao	CN11	Detect ambient temp.	PLs	CN8	Liquid pipe pressure sensor (used for customized model)	Toil1	CN17	Detect the oil temp. of compressor
Toa1	CN12	Detect SH temp. in heating	CT1	CN9	Current detector	Tdef1	CN18	Detect the defrosting temp.
Ts	CN1	Detect the suction temp. of gas-liquid separator	HPS1	CN21	High pressure switch	LEV8	CN24	SH control in sub-cooler control
To2	CN36	Detect the oil temp. of the compressor	Td1	CN3	Detect discharging temp. of INV compressor	LEVA1	CN25	SH control in heating
To2	CN7	Detect SH temp. in heating	PS	CN6	Low pressure sensor	LEVA2	CN26	SH control in heating
HPS2	CN22	High pressure switch	Toip	CN15	Detect the oil balance pipe temp.	LEV3	CN6	Liquid pipe pressure sensor (used for customized model)

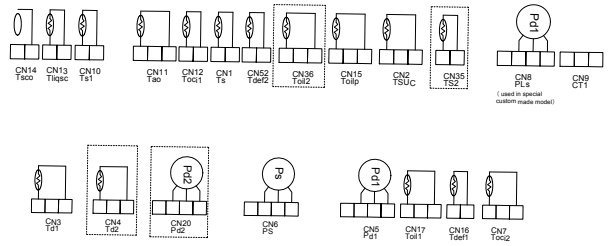

6. Capacity Calculation Due to Capacity Modification Coefficient

(1) Calculation method of cooling capacity---Refrigerating capacity to be known=Refrigerating capacity x(AxBxCxDxExFxG) W

A Capacity compensation coefficient of indoor air wet-bulb temperature condition.

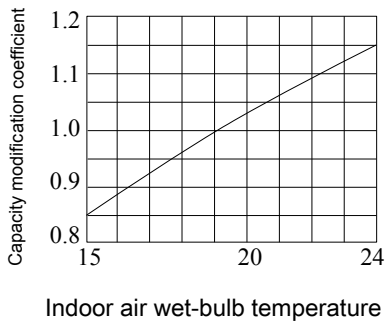

B Capacity compensation coefficient of outdoor air dry-bulb temperature condition.

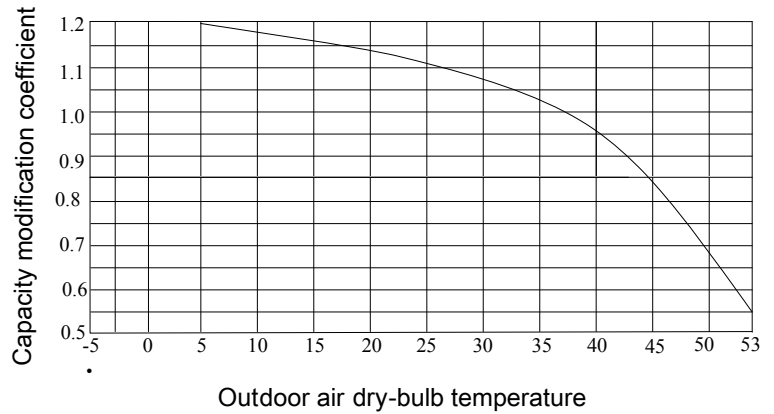

C Capacity modification coefficient under airflow variation rate of indoor unit group(only for duct unit)

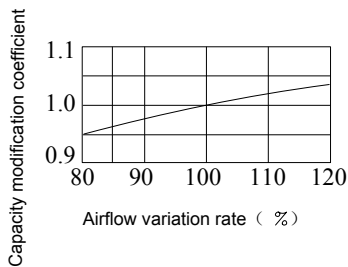

D. Capacity compensation value at different piping length and drop

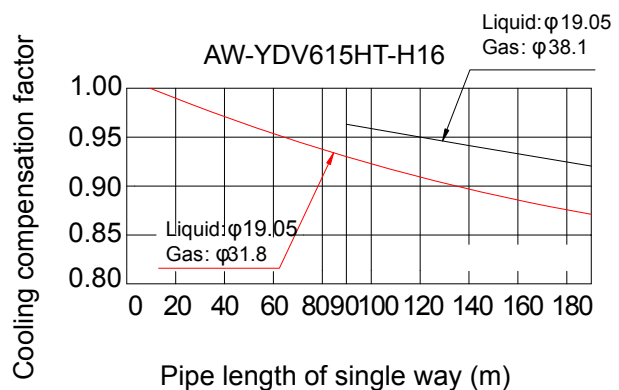
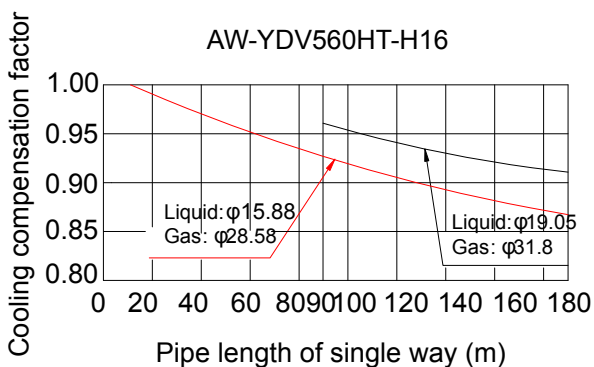
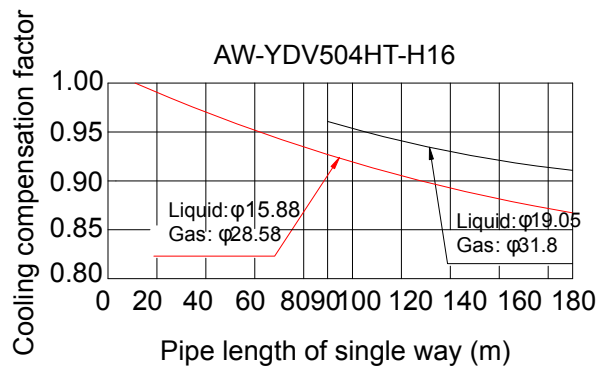
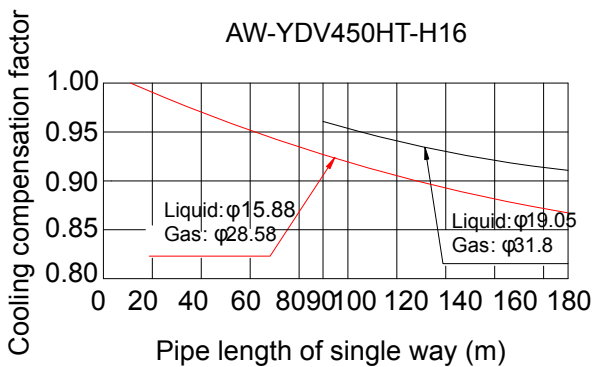
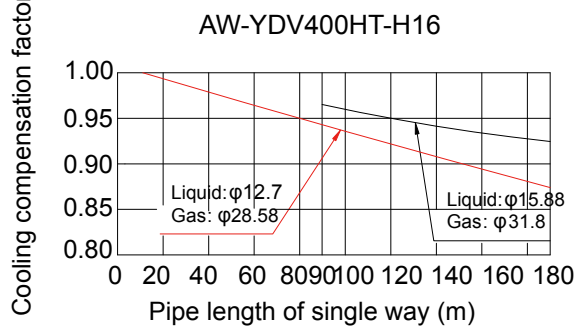
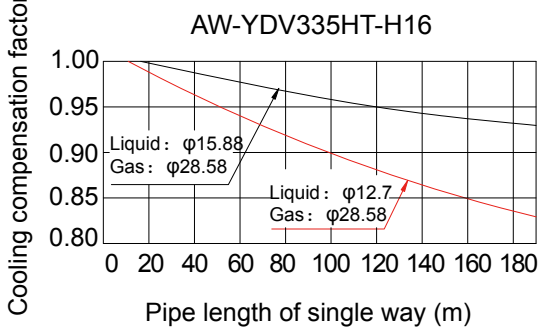
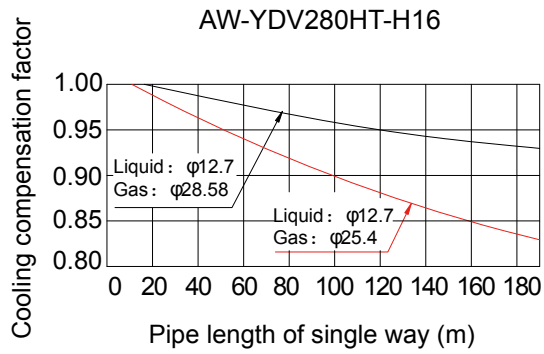
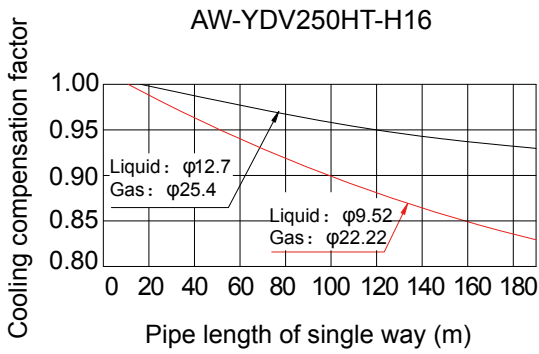

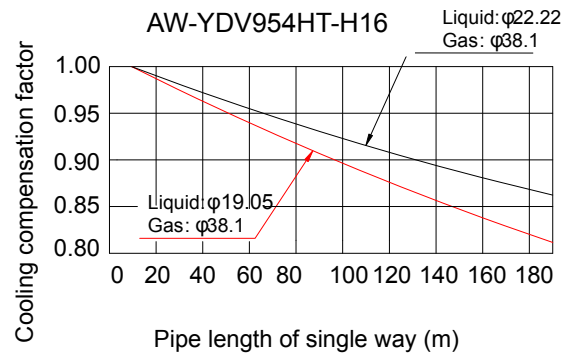
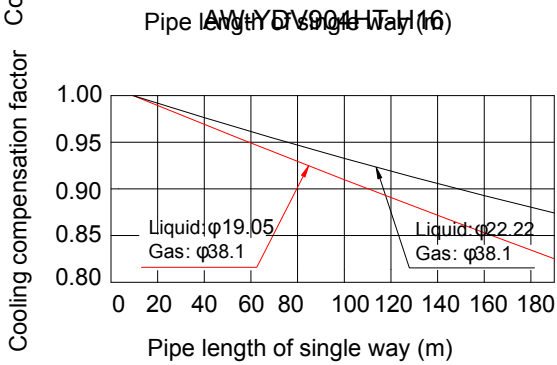
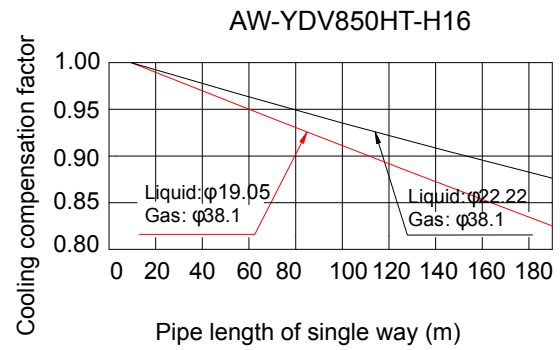
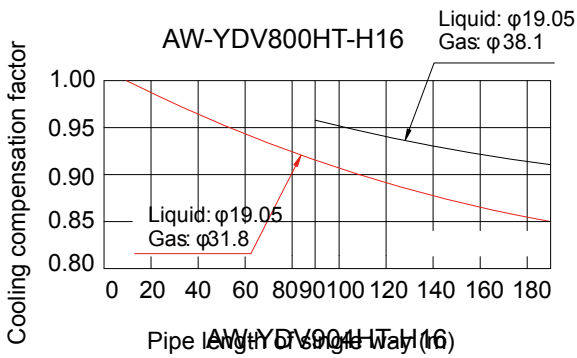
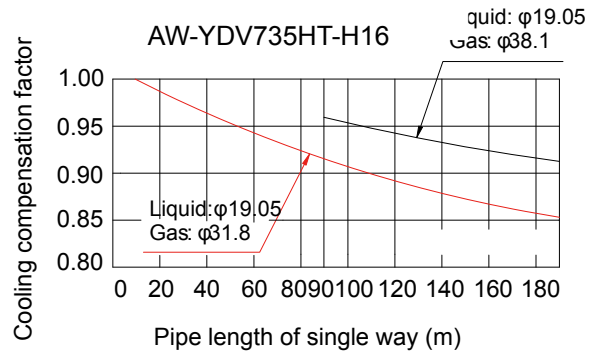
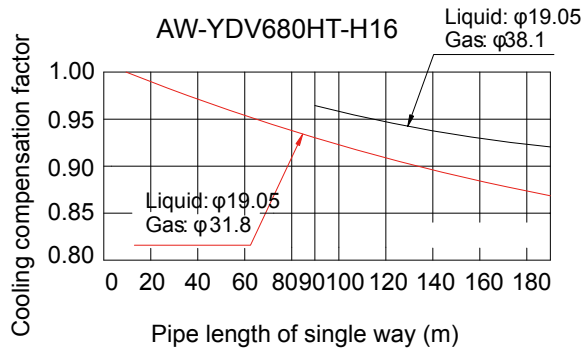

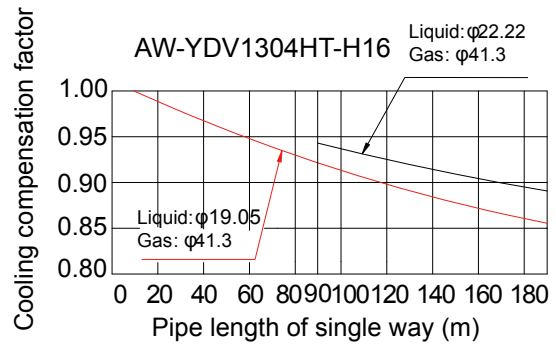
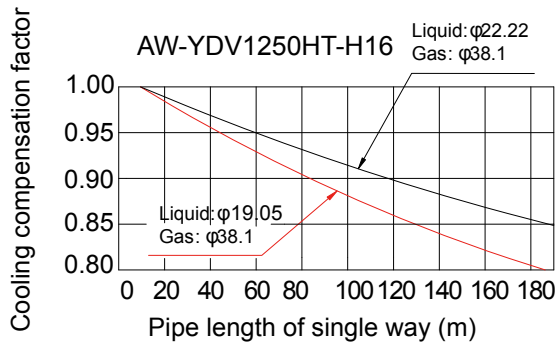
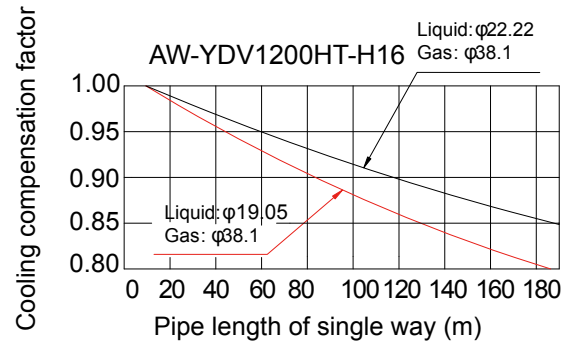
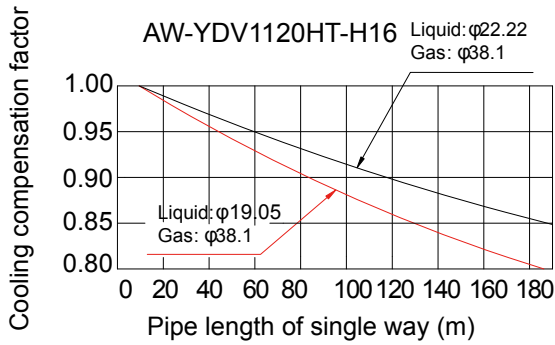
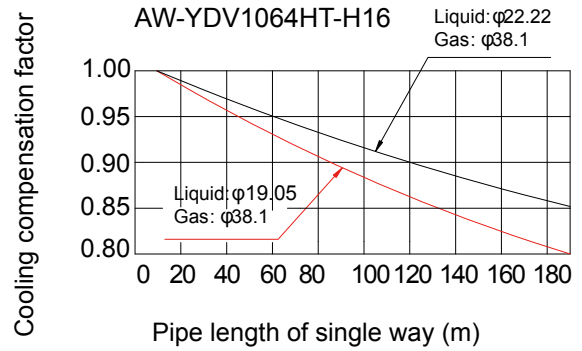
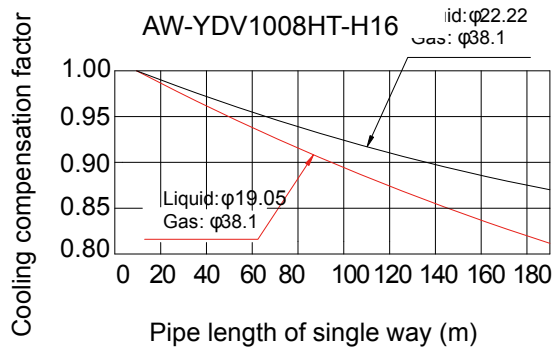

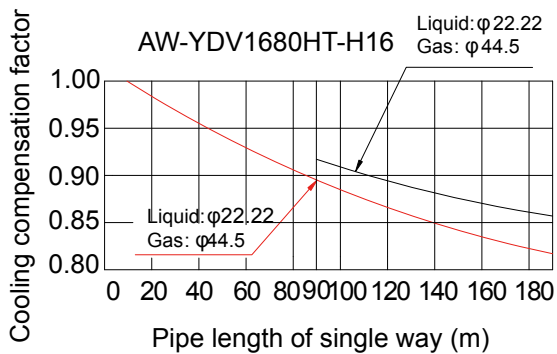
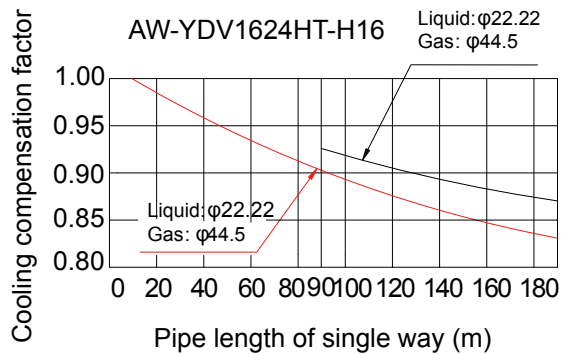
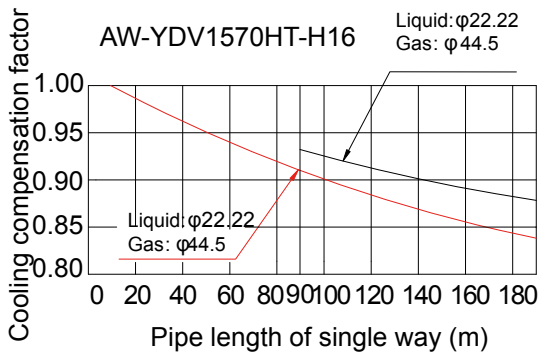
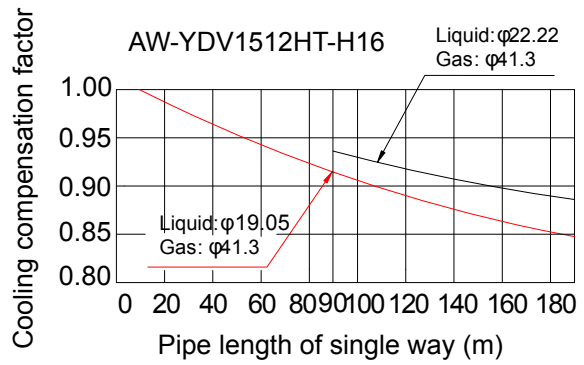
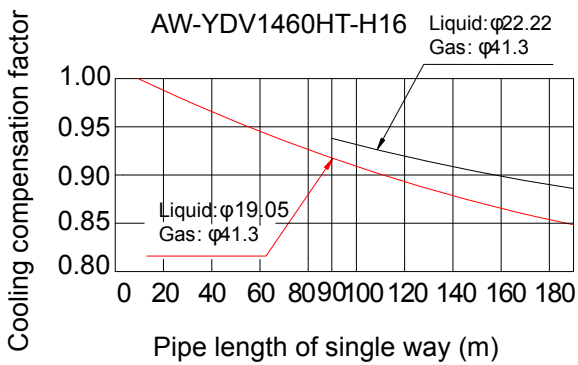
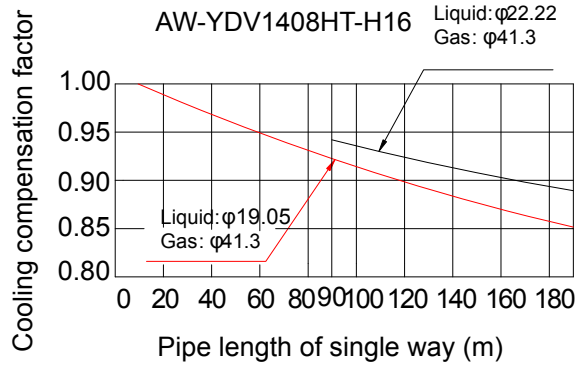
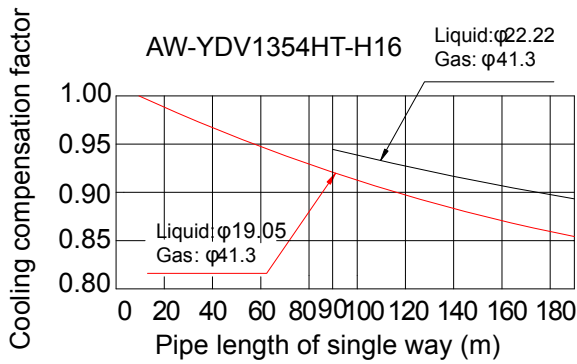

Note:

When the pipe length more than 90 m, the pipe diameter need be expanded.

E. Capacity compensation suitable for total capability of indoor unit group

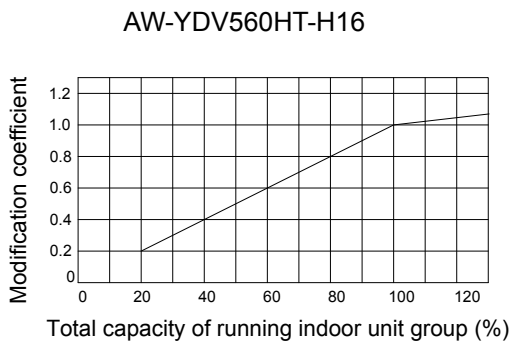
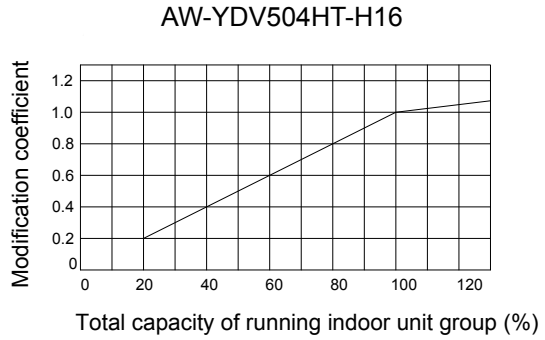
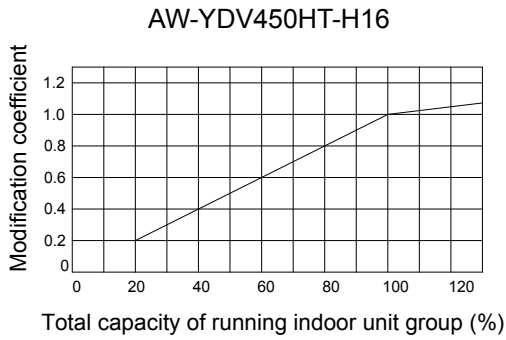
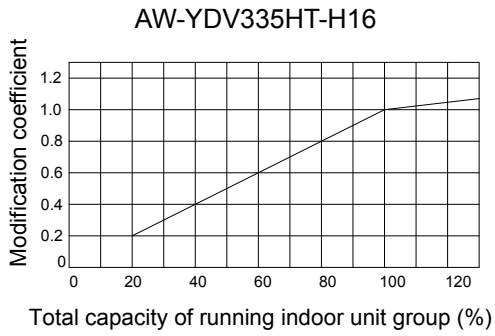
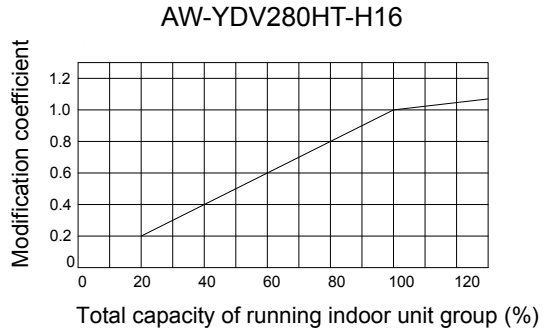
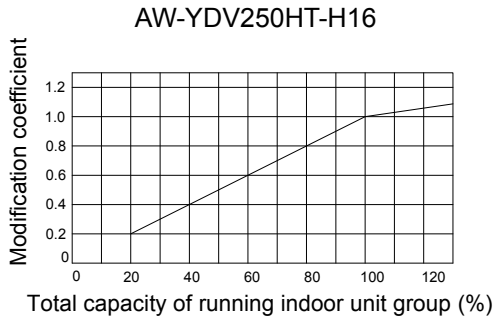

Note:

The modification capacity of the combination models is equal to the sum of the single model modification capacity.

(2) Calculation method of heating capacity---Heating capacity to be known=Heating capacity x(AxBxCxDxExFxG) W

A. Capacity modification value under indoor air dry-bulb temperature condition.

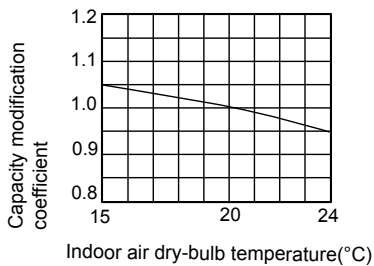

B. Capacity modification value under outdoor air wet-bulb temperature condition.

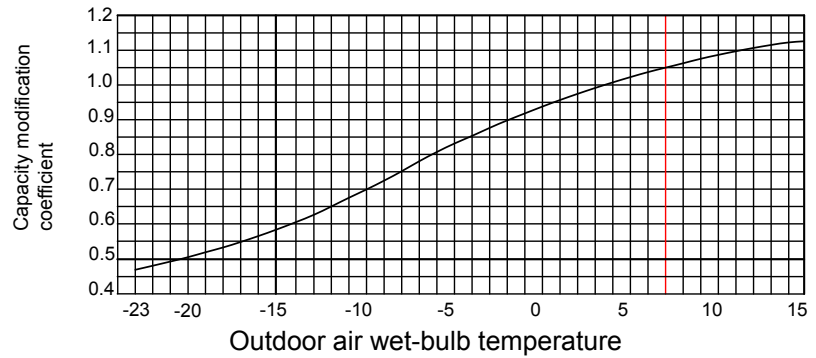

C. Capacity compensation value at different piping length and drop

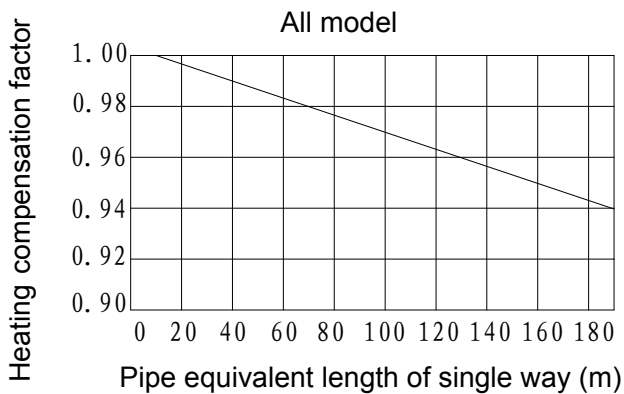

Note:

Refrigerant pipe equivalent length = \sum each size gas pipe elbow quantity \times elbow equivalent length + \sum each size straight pipe length

Elbow equivalent length:

Unit: m /apice

Gas pipe size	φ15.88	φ19.05	φ22.22	φ25.4	φ28.58	φ31.8	φ34.9	φ38.1	φ41.3	φ44.5	φ47.6	φ50.8
Joint (90°elbow)	0.25	0.3	0.35	0.4	0.45	0.55	0.6	0.65	0.7	0.75	0.8	0.85

D. Capacity compensation suitable for outdoor unit frosting

The wet-bulb temperature of outdoor suction air (°C)	-20	-15	-13	-11	-9	-7	-5	-3	-1	1	3	> 3
Compensation coefficient	0.96	0.96	0.96	0.95	0.94	0.93	0.91	0.88	0.86	0.87	0.92	1

E. Capacity compensation suitable for total capability of indoor unit group

AW-YDV250HT-H16

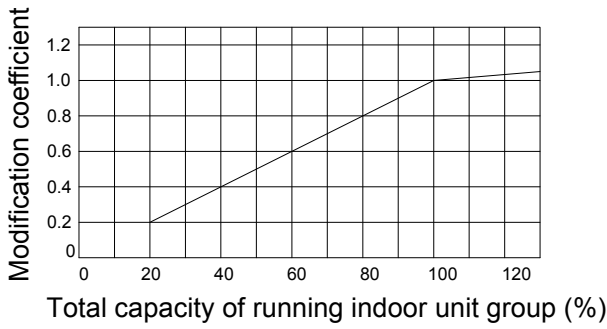

AW-YDV280HT-H16

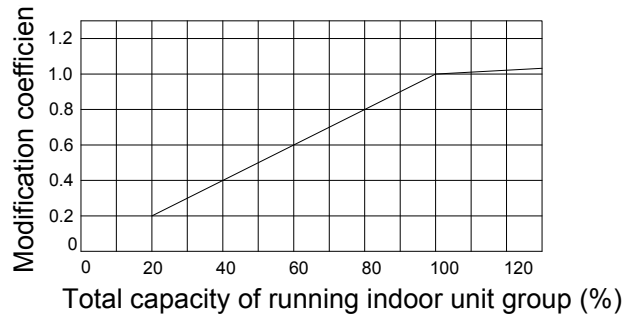

AW-YDV335HT-H16

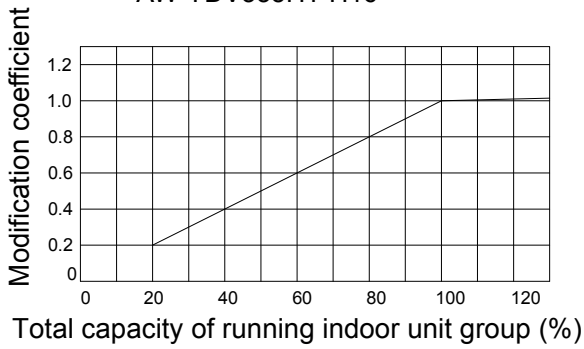

AW-YDV400HT-H16

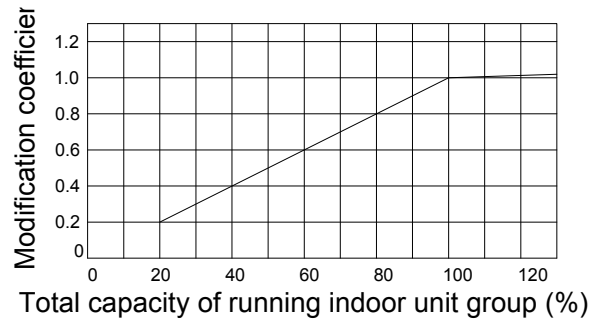

AW-YDV450HT-H16

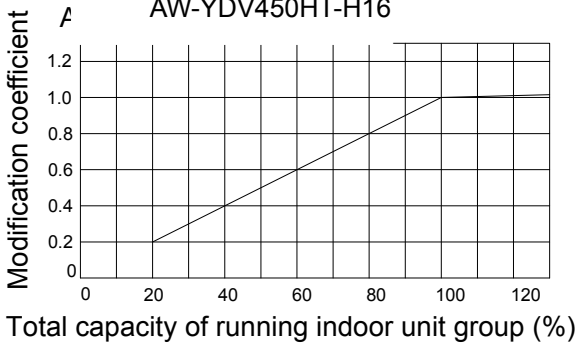

AW-YDV504HT-H16

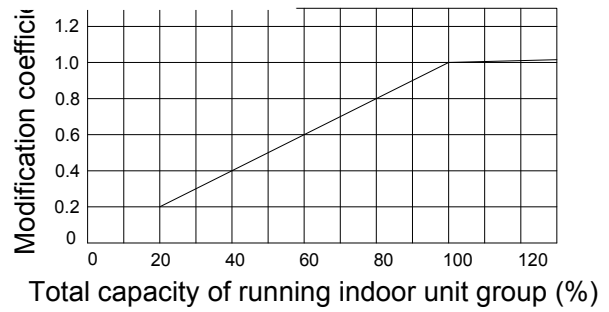

AW-YDV560HT-H16

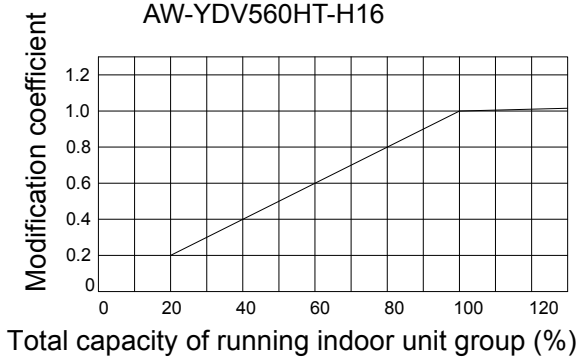

Note:

The modification capacity of the combination models is equal to the sum of the single model modification capacity.

(3) Capacity compensation value for cooling and heating

F. In cooling, when the outdoor lower than the indoor, or in heating the outdoor higher than the indoor, the compensation factor use the curve value minus the following table value

The vertical height difference between indoor and outdoor unit	5m	10m	15m	20m	25m	30m	35m	40m	45m	50m
Adjustment coefficient	0.99	0.98	0.97	0.96	0.95	0.94	0.93	0.92	0.91	0.90

G. Capacity compensation suitable for outdoor outlet static pressure

Outdoor outlet static pressure (Pa)	0	10	20	30	40	50	60	70	80
Adjustment coefficient	1	1	0.99	0.98	0.97	0.96	0.95	0.94	0.93

7. Operation Range

Cooling

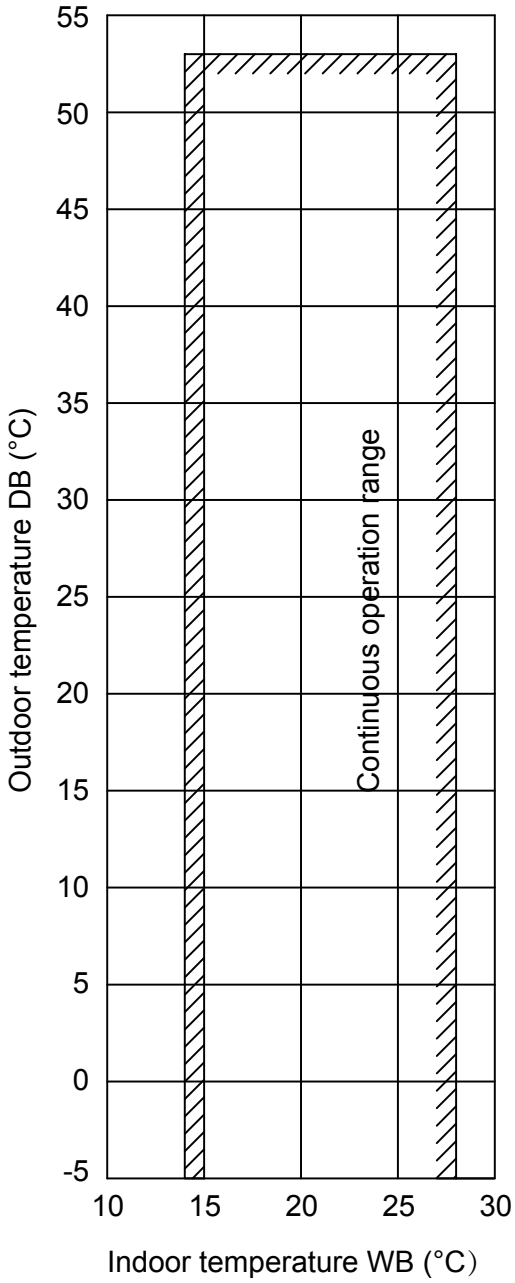

Heating

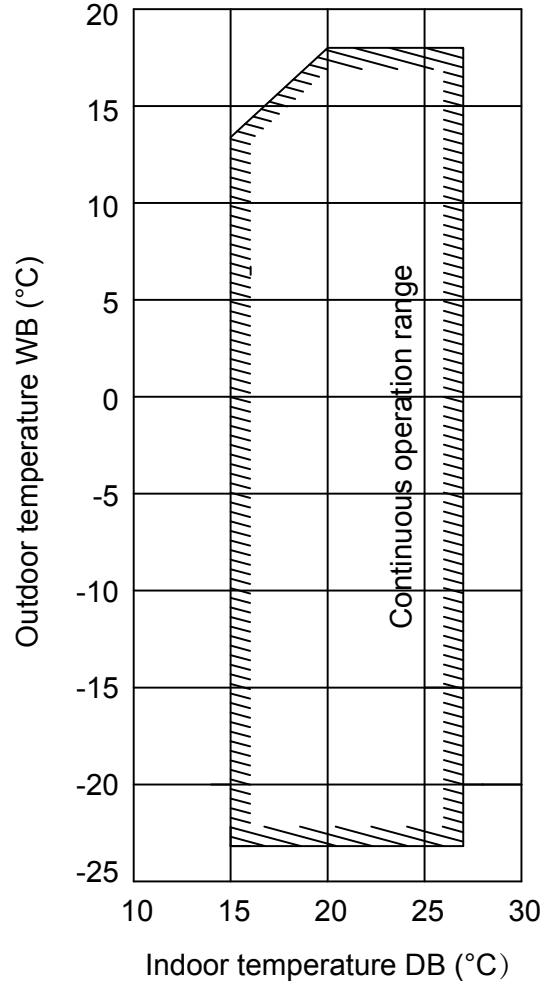

8. Noise Level

1) Testing illustrate

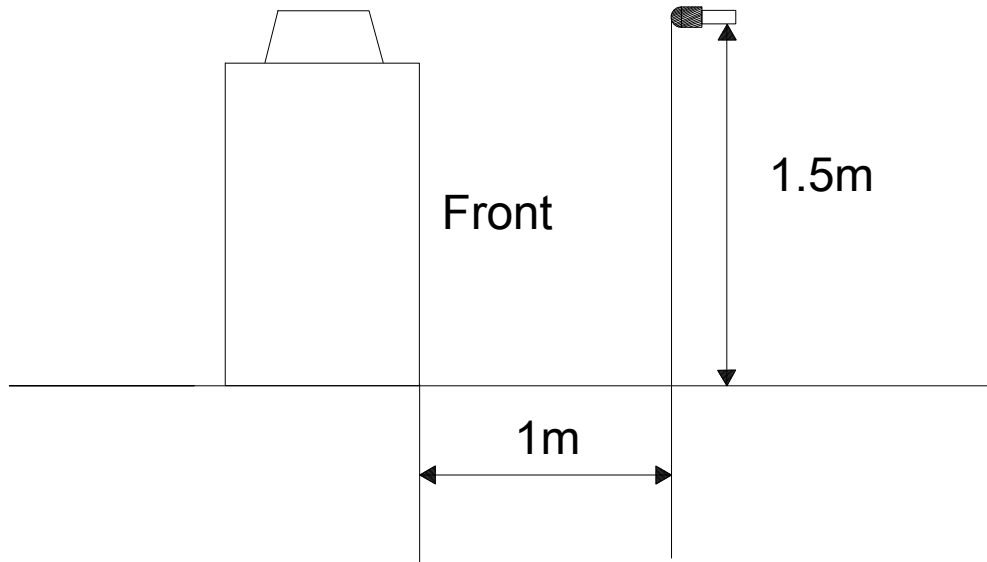

2) Octave band level

AW-YDV250HT-H16 AW-YDV280HT-H16

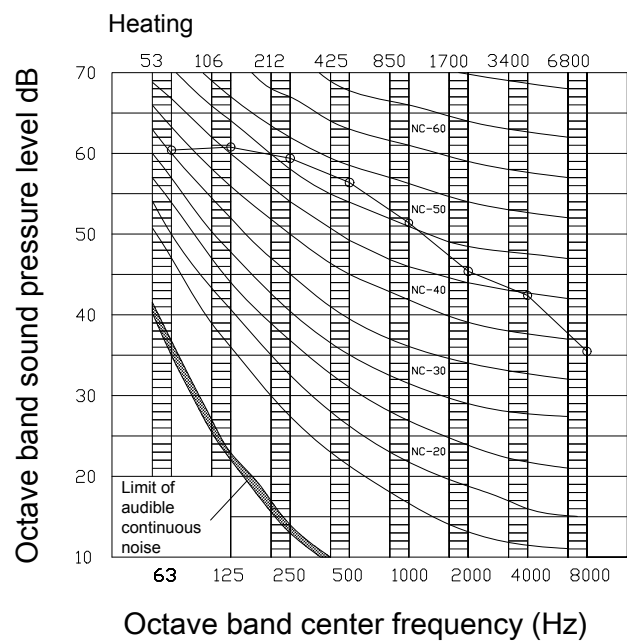
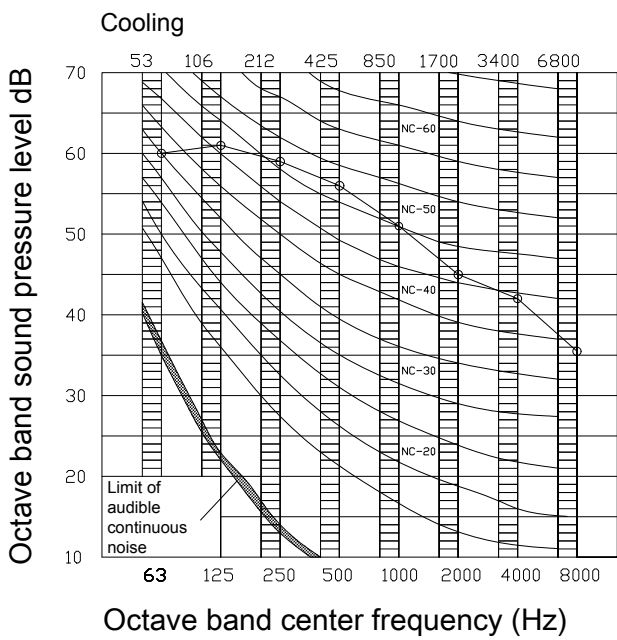

AW-YDV335HT-H16

Cooling

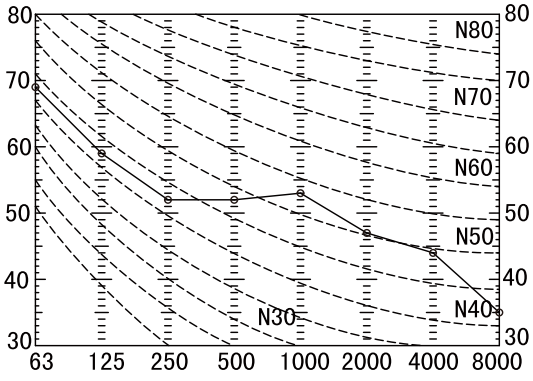

Octave band center frequency (Hz)

Heating

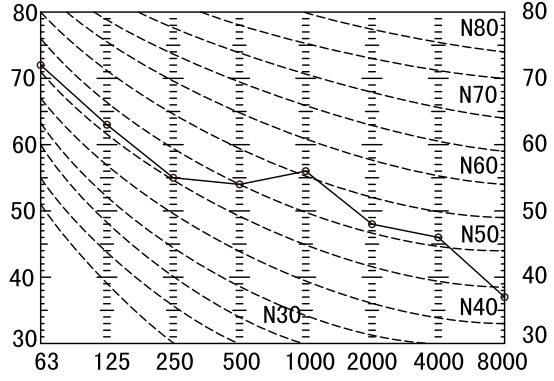

Octave band center frequency (Hz)

AW-YDV400HT-H16

Cooling

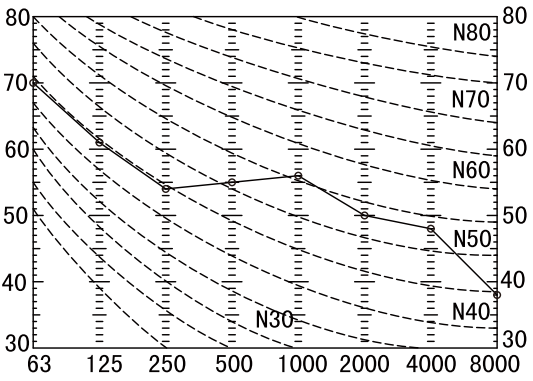

Octave band center frequency (Hz)

Heating

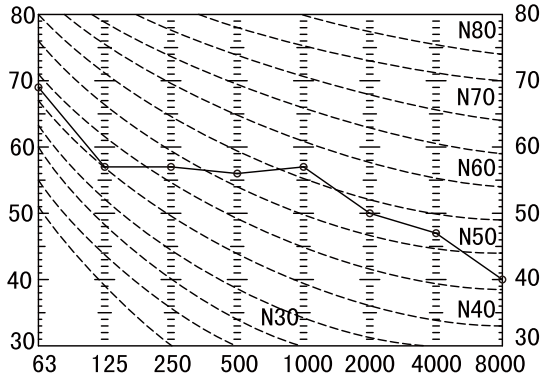

Octave band center frequency (Hz)

AW-YDV450HT-H16

Cooling

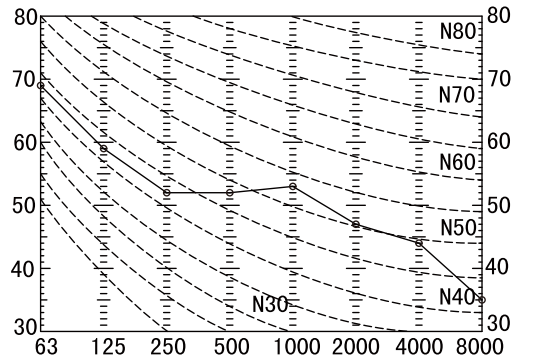

Octave band center frequency (Hz)

Heating

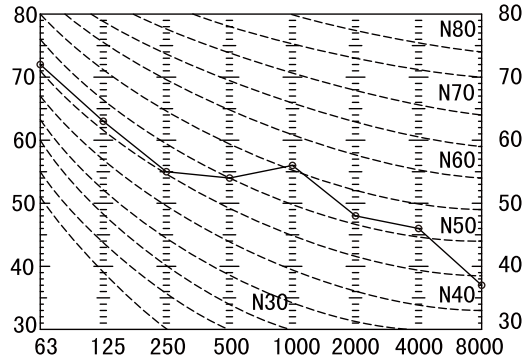

Octave band center frequency (Hz)

AW-YDV504HT-H16

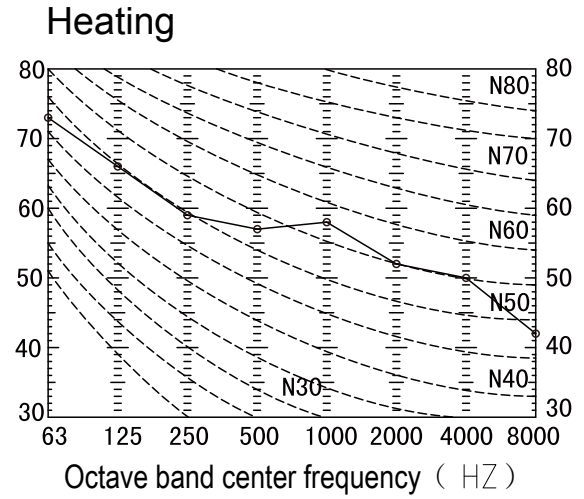
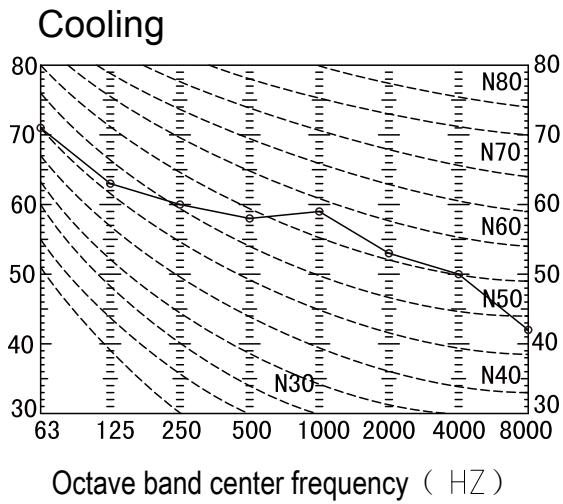

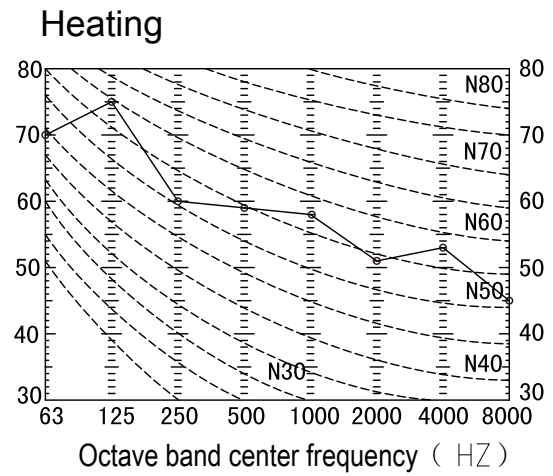
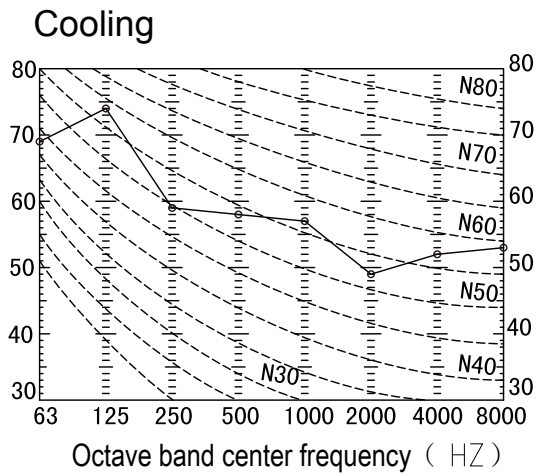

AW-YDV560HT-H16

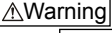

9. Installation

9.1 Safety

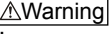
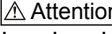
- Please read this installation manual carefully before installation and operation.
- The mentioned precaution includes  and . The precaution that will avoid death or heavy injury by faulty installation will be listed in . Even the violation of the cautions listed in  also may cause serious accidents. So both of them are related to the safety, and should be executed seriously.
- The meanings of "graphical symbol" used here are described below.

	Absolutely prohibited	 	The instructions must be followed
---	-----------------------	---	-----------------------------------

- After installation, perform a trial and confirm everything normal, then introduce the operation manual to the user. Besides, put the manual to the user and ask them to preserve it carefully.

Warning



- The installation should be executed correctly as the installation manual, or the faulty installation will cause water leakage, electric shock, fire or unit dropping, further leading to injury, etc accidents.
- The installation should be performed by the retailer or professional installation institution.
- If the users conducting the installation have any improperness, water leakage, electric shock, fire and unit dropping will be induced and further result in injury, etc.
- If installation and maintenance require to operate inside the unit, the current should be cut off before the operation, or electric shock will be induced.
- If installation requires to operate in a small room, appropriate measures must be taken. Please ensure that the refrigerant will not exceed the concentration limit (0.3 kg/m³) in case of possible leakage. During installation, the proper measures to ensure the concentration limit should be consulted with the retailer. Otherwise, it will cause oxygen deficit once the refrigerant leaks and exceeds the concentration limit.
- Please install the unit at the space which can bear the weight. Otherwise, the unit will drop down or turn over to cause the human injury.
- The specified installation should defend against the typhoon and other strong wind as well as earthquake, etc. Otherwise, any improperness in the installation will cause the unit turnover and further induce accidents.
- Please hang the ropes which can bear the weight to the specified location of the unit when transporting the unit. Otherwise, any improper handling method will cause the unit dropping and further induce death or serious injury.
- When installation, please use the accessories with the unit or the specified parts. Otherwise, it will cause the unit dropping, water leakage, fire, electric shock, refrigerant leakage, insufficient performance, poor control, etc.

 Warning

- Please use the products specified by the company, such as air cleaner, humidifier, electric heater and other products sold separately.
Besides, the installation should be performed by the retailer or professional installation institution. If the users conducting the installation have any improperness, water leakage, electric shock, fire and unit dropping will be induced and further result in injury, etc.
- The electric work must be performed by the personnel with qualification of electrician who should be in accordance with Relevant Technical Standards for Electrical Equipment, Interior Wiring Regulations and the installation manual, and also should use dedicated circuit.
Otherwise, insufficient capacity of power circuit or improper construction will cause electric shock and fire.
- Please use the specified cable to make reliable earthing and fix the terminal firmly.
Otherwise, loose connection will cause heating, fire or electric shock, etc.
- Please confirm that there is no dust, blockage or looseness on the power joint and also conduct connection correctly.
Otherwise, it will cause electric shock or fire.
- The wiring should be in shape and cannot be raised. Ensure the maintenance panel to install correctly.
Otherwise, the improper installation will cause heating, fire or electric shock, etc.
- Please install the refrigerant pipe correctly before running of compressor.
If the compressor is running when refrigerant pipe has not been installed and operating valve has been open, the refrigerant will leak seriously, thus resulting in cold injury and other injury. Besides, it will have the air in the refrigeration system and thus lead to abnormal high pressure in refrigeration system, further inducing breakage, injury, etc.
- Operating valve (both gas side and liquid side) cannot be open before completion of refrigerant pipe works, airtight test and vacuum pumping.
Serious leakage of the refrigerant will cause cold injury and other injury. In addition, if refrigerant leaks during operation, pipe brazing and other works must be interrupted for ventilation. Furthermore, the refrigerant will cause poisonous gas as meeting fire.
- Use R410A special tools for pipe, flared nut and other tools.
If the existing components (beyond R410A) are used, it will cause the machine fault, the rupture of refrigeration cycle system, injury and other major accidents.
- Use the torque wrench for flared nut and double-ended wrench to tighten the nut as per appropriate torque.
If the flared nut is tightened excessively, it will rupture after a long time, thus inducing refrigerant leakage. And looseness and damage of the flaring part will cause refrigerant leakage and further induce oxygen deficit accident.
- During pumping operation, shut down the compressor before refrigerant pipe being removed.
If the refrigerant pipe is removed when the compressor is running and operating valve has been opened, the refrigerant will leak seriously, thus resulting in cold injury and other injury. Besides, it will have the air in the refrigeration system and thus lead to abnormal high pressure in refrigeration system, further inducing breakage, injury, etc.



⚠ Warning





- If refrigerant leaks during operation, please take measures for ventilation and aeration. the refrigerant will cause poisonous gas as meeting fire.
- After installation, please confirm whether or not there is refrigerant leakage. If the refrigerant leaks indoors, it will generate poisonous gas after meeting fan heater, furnace, oven and other fire sources.
- If the supply cord is damaged, it must be replaced by the manufacturer, its service agent or similarly qualified persons in order to avoid a hazard.
- This appliance is not intended for use by persons (including children) with reduced physical, sensory or mental capabilities, or lack of experience and knowledge, unless they have been given supervision or instruction concerning use of the appliance by a person responsible for their safety.
- Children should be supervised to ensure that they do not play with the appliance.
- This appliance can be used by children aged from 8 years and above and persons with reduced physical, sensory or mental capabilities or lack of experience and knowledge if they have been given supervision or instruction concerning use of the appliance in a safe way and understand the hazards involved. Children shall not play with the appliance. Cleaning and user maintenance shall not be made by children without supervision.
- The appliances are not intended to be operated by means of an external timer or separate remote-control system.
- Keep the appliance and its cord out of reach of children less than 8 years.



- Operating valve (both gas side and liquid side) cannot be open before completion of refrigerant pipe works, airtight test and vacuum pumping and other steps.
- Rapid leakage of the refrigerant will cause cold injury or other injury.
- Drainage pipe cannot be connected directly to drainage tank which produces sulfur gases and other harmful gases.
- Otherwise, the poisonous gas may enter the indoor. Besides, it may corrode indoor units and cause fault of indoor units or leakage of the refrigerant.
- During installation or relocation of air conditioner, the air other than the specified refrigerant (R410A) cannot be mixed into refrigeration cycle system.
- If the air is mixed into the system, it will generate abnormal high pressure in refrigeration cycle system, further inducing breakage, injury, etc.

⚠ Attention

	<ul style="list-style-type: none"> • Ensure the specified space for inspection and maintenance. The insufficient space will cause dropping from installation site and further induce injury. • When installing outdoor unit on the roof or the other high place, to prevent the person falling down, please set fixed ladder, handrail in the passage, or equip railing and handrail around the outdoor unit. • The installation should be executed correctly as the installation manual, or it will cause abnormal vibration and noise increase. • After completion of refrigerant pipe works, conduct airtight test via nitrogen to ensure that there is no leakage. It will cause oxygen deficit once the refrigerant leaks in a small room or exceeds the concentration limit. • Dewing prevention and heat insulation is necessary for refrigerant pipe. Otherwise, it will cause water leakage, water dropping, moistening of household articles, etc. • Install residual-current circuit breaker (RCCB). Otherwise, it will cause fire and electric shock. • The drainage pipe works should be executed correctly as the installation manual. Ensure proper drainage, and heat insulation to prevent dewing. Otherwise, it will cause water leakage, water dropping, moistening of household articles, etc.
	<ul style="list-style-type: none"> • Connect ground wires correctly. (grounded). Ground wires cannot be connected to gas pipe, water pipe, lightning rod, telephone or other ground wires. Incorrect ground wires (grounded) will cause fault, fire. And electric leakage will cause electric shock. Besides, if ground wires are connected with gas pipe, explosion and fire may be induced if the gas leaks.
	<ul style="list-style-type: none"> • Don't use the unit to preserve food, animals and plants, precision instruments and artworks, or for other special purposes. It may reduce the quality of preserved goods. • Outdoor unit cannot be installed in the place that easily becomes nest of small animals. If any small animals enter the unit and get in touch with internal electronic components, it will cause fault, smoking or fire. Besides, remind users to keep the surroundings clean. • Don't use packing belt for handling. • Don't handle packing woods with bare hands. • Don't install the unit in place with possible leakage of combustible gas or with combustibles. If the unit is installed in the place with possible leakage, generation, access and retention of combustible gas or the place with floating of carbon fiber, it will cause fire. • Don't install the unit in place where the wind from fan will direct at animals and plants. Otherwise, the wind will affect plants, etc.

⚠ Attention



- During operation, don't place any object on outdoor unit. If the object falls, it will be damaged or broken.
- Don't climb to outdoor unit. Otherwise, it will cause falling, turnover, etc, thus inducing injury.

Instructions applicable to unit type with R410A refrigerant

- Don't use the refrigerant except for R410A. The R410A has the pressure 1.6 times higher than that of the previous refrigerant.
The refrigerant R410A tank is marked with pink sign.
- Against charging different refrigerant, we change the diameter injection hole for operating valve of outdoor unit and that of the check joint diameter of the R410A unit.
To enhance the compression consistence, for refrigerant pipe, we also change machining dimension of refrigerant flared pipe and opposite side dimension of flared nut.
When construction and maintenance, prepare the R410A special tools according to the below table.
- Don't use aeration tank, or it will cause changes of refrigerant composition and lack of refrigeration capacity.
- When filling the refrigerant, make sure to take it out of refrigerant tank in liquid form.
- Indoor unit refers to R410A appropriate unit. Please confirm the indoor unit available for connection according to the catalogue. (If other indoor unit is connected, normal operation will be impossible.)

R410A special tools	
a	Pressure gauge of manifold
b	Charge hose
c	Electronic balance for charging refrigerant
d	Torque wrench
e	Flare tool
f	Copper pipe gauge for adjustment of exposed length
g	Vacuum pump adapter
h	Gas leakage detector

9.2 Before installation

Before installation, check if unit type, power specification, pipe, wires and parts purchased respectively are correct.

Attention

- Make sure to read the manual before installation and conduct the installation accordingly.
- Please refer to installation manual of indoor unit when installing it.
- In pipe works, please refer to the manual for distribution spare parts (branch pipe and gather pipe) which sold separately.
- Make sure to equip leakage current protector (please chose the product resisting to high-order harmonic).
- The compressor may be burnt in case of running without discharge pipe thermistor, suction pipe thermistor and pressure sensor. Thus it is necessary to avoid such operation.

Combination form

- Combination form of outdoor unit as well as the quantity and capacity of connected indoor unit are shown in the table below.
- The connected indoor unit must be R410A appropriate unit. Please determine the type of indoor unit available for connection based on the manual.
- It can be used in combination with the following indoor units.

HP	Model of outdoor unit	Combination type	Quantity of units connected	Total capacity of indoor units available for connection (HP)
8	AW-YDV250HT-H16	Separate	1~13	4~10.4
10	AW-YDV280HT-H16	Separate	1~16	5~13
12	AW-YDV335HT-H16	Separate	1~20	6~15.6
14	AW-YDV400HT-H16	Separate	1~24	7~18.2
16	AW-YDV450HT-H16	Separate	1~27	8~20.8
18	AW-YDV504HT-H16	Separate	1~30	9~23.4
20	AW-YDV560HT-H16	Separate	1~33	10~26
22	AW-YDV615HT-H16	Combined (10HP+12HP)	2~36	11~28.6
24	AW-YDV680HT-H16	Combined (10HP+14HP)	2~40	12~31.2
26	AW-YDV735HT-H16	Combined (12HP+14HP)	2~43	13~33.8
28	AW-YDV800HT-H16	Combined (14HP+14HP)	2~46	14~36.4
30	AW-YDV850HT-H16	Combined (14HP+16HP)	2~50	15~39
32	AW-YDV904HT-H16	Combined (14HP+18HP)	2~53	16~41.6
34	AW-YDV954HT-H16	Combined (16HP+18HP)	2~57	17~44.2
36	AW-YDV1008HT-H16	Combined (18HP+18HP)	2~60	18~46.8
38	AW-YDV1064HT-H16	Combined (18HP+20HP)	2~64	19~49.4
40	AW-YDV1120HT-H16	Combined (20HP+20HP)	3~64	20~52
42	AW-YDV1200HT-H16	Combined (14HP+14HP+14HP)	3~64	21~54.6
44	AW-YDV1250HT-H16	Combined (14HP+14HP+16HP)	3~64	22~57.2
46	AW-YDV1304HT-H16	Combined (14HP+14HP+18HP)	3~64	23~59.8

HP	Model of outdoor unit	Combination type	Quantity of units connected	Total capacity of indoor units available for connection (HP)
48	AW-YDV1354HT-H16	Combined (14HP+16HP+18HP)	3~64	24~62.4
50	AW-YDV1408HT-H16	Combined (14HP+18HP+18HP)	3~64	25~65
52	AW-YDV1460HT-H16	Combined (16HP+18HP+18HP)	3~64	26~67.6
54	AW-YDV1512HT-H16	Combined (18HP+18HP+18HP)	3~64	27~70.2
56	AW-YDV1570HT-H16	Combined (16HP+20HP+20HP)	3~64	28~72.8
58	AW-YDV1624HT-H16	Combined (18HP+20HP+20HP)	3~64	29~75.4
60	AW-YDV1680HT-H16	Combined (20HP+20HP+20HP)	3~64	30~78

Notes:

Capacity allocation ratio of indoor and outdoor units series ranges between 50% and 130%, but the capacity of simultaneously operating indoor unit cannot be greater than 100% of the capacity of the operating outdoor unit.

[Separately sold products]

Separate spare parts for refrigerant pipe are required during installation.

For spare parts of refrigerant pipe, installation of outdoor gathering pipe (with specification of TBS) requires for manifold (with specification of TAU) outdoor. Please select it according to installation items of refrigerant pipe in item 4.

Please consult the retailer or the company in case of any question.

Refrigerant manifold and gathering pipe must be appropriate products of the R410A.

9.3 Installation location

Please obtain user's consent for selection of installation location.

Selection of installation location

- The place without air trapping.
- Install the unit body in the firm position.
- The place where air inlet and air outlet is free of ventilation obstacle.
- The place is free from heat radiation of other heat sources.
- The place where exhaust port will not be subject to strong wind.
- The place where electrical noise is not subject to strict restrictions.
- The place with sound drainage.
- The place where noise and hot air will not produce negative impact to the neighbors.
- The place that will not be buried by snow.
- More than 5m away from the TV set and the radio.
(Far away from electromagnetic interference as much as possible.)

Warning:

- (A) Install wind adapter in case of possible short circuit.
- (B) In order to avoid short circuit, ensure sufficient inlet air space when installing multiple units.
- (C) When using the unit in snow area, install stand and snow mantle to avoid the snow burying the unit body.
(Don't adopt centralized drainage in snow area.)
- (D) Don't install the unit in place subject to possible leakage of flammable gas.
- (E) Install the unit in a firm position which can bear the unit weight.
- Please consult the retailer for wind adapter, snow mantle, supporting components for centralized drainage and other separately sold parts.

Attention

Please make sure to provide sufficient installation space.
Otherwise, the compressor and instrument may be failure due to short circuit.

Installation space (maintenance space) example

Guarantee maintenance space (space for maintenance, passage, air duct and pipe placement).
(Consult with the retailer or the company in case of not meeting installation conditions as shown in the figure.)

① When installing single unit

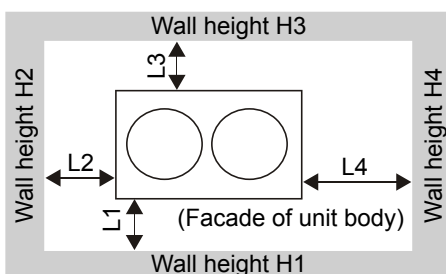

Installation example	I	II	III
Size			
L1	500	500	Open
L2	10	50	10
L3	100	50	100
L4	10	50	Open
H1	1500	1500	Open
H2	Unrestricted	Unrestricted	Unrestricted
H3	1,000	1,000	Unrestricted
H4	Unrestricted	Unrestricted	Open

② When installing multiple units

In general, reserve at least 10mm (L5 and L6) at both sides of unit body during installation.

Reference:

Dimensions of all outdoor unit series (8P~24P) are 1350mm × 720mm.

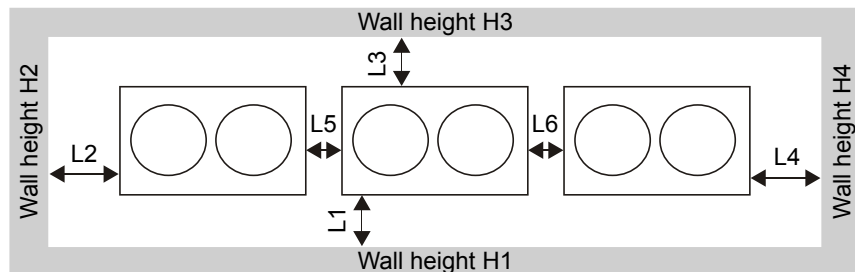

Installation example	I	II
Size		
L1	500	Open
L2	10	200
L3	100	300
L4	10	Open
L5	10	400
L6	10	400
H1	1500	Open
H2	Unrestricted	Unrestricted
H3	1000	Unrestricted
H4	Unrestricted	Open

9.4 Unit transport and installation

⚠ Attention

When ropes are used for transporting unit, it is necessary to consider shift of gravity center of the unit. The unit may fall due to loss of stability.

9.4.1. Transport

- Please determine handling route and handle the unit with package to the installation location.
- To avoid damaging the unit during hoisting, protect the unit with cloth liner and lift it with two pieces of cloth ropes.

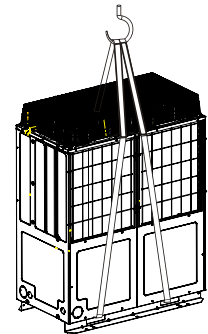

Warning:

- (A) The ropes must pass through the corner hole of fixing foot of the unit.
- (B) To avoid damaging the unit, make the ropes touch the unit along bottom plate and cloth liner.

9.4.2. Attentions during installation

(1) Position of fixing bolt

- Please use 4 fixing bolts (M10) to fasten fixing feet of outdoor unit. The bolts with specification of 20mm are preferable.

unit: mm

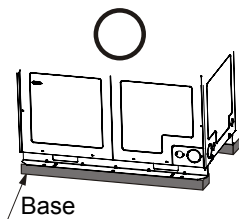
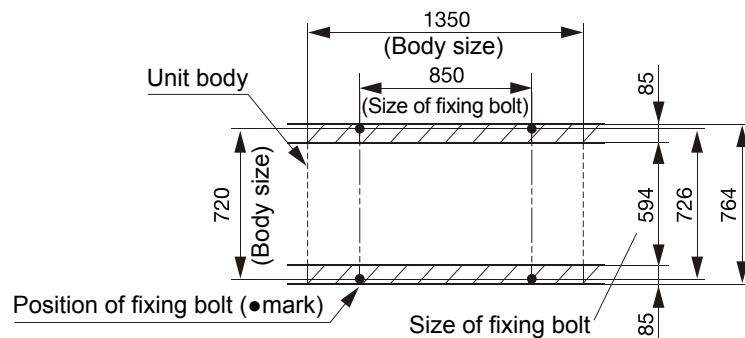
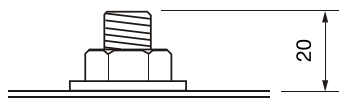

Generally set the base according to the figure above

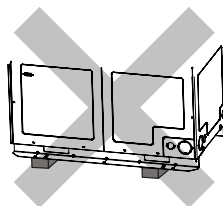

Do not refer to the previous unit type for base direction

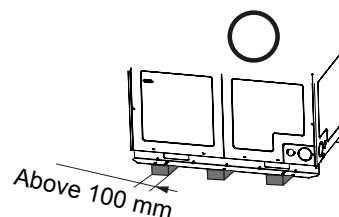

Use it when conducting updating (adding base in the middle) to prevent bending.

(2) Base

- During setting, confirm base strength and levelness and whether vibration and noise are produced.
- As to base size, set it as the scope above oblique lined area (above the front of fixing foot of outdoor unit) in the figure above.
- Set the base in side direction of outdoor (in the direction with width of 1,350 mm) as per the figure above.

(3) Shake-proof rubber

- The installed shake-proof rubber should be of the size enough to support the whole fixing feet of outdoor unit. (Please refer to the figure below.)

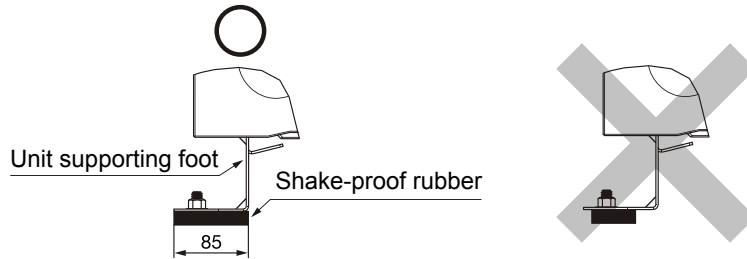

Warning:



- When setting shake-proof rubber, pay attention to making the lower part of unit fixing foot touch the ground completely.
- Prevent the lower part of supporting foot for unit fixing being exposed from shake-proof rubber or avoid setting shake-proof rubber in part.

9.5 Construction of refrigerant pipe

9.5.1. Determining pipe specifications

(Keep specifications of indoor unit consistent with installation site and select them according to the following contents.)

(1) Restriction of piping

- During pipe construction, make sure to follow the maximum length, total pipe length, allowable length of pipeline to the first manifold, allowable height difference (level difference) and other restrictions on specifications in (1).
- Avoid concave pipe () and convex pipe () in the pipeline as much as possible; otherwise, oil may accumulate.

Important notes

Separate the refrigerant system when exceeding values in the table below in terms of filling quantity of refrigerant pipe.

Outdoor unit	Additional sealing-in quantity (kg)
8HP~20HP	50
22HP~40HP	100
42HP~60HP	150

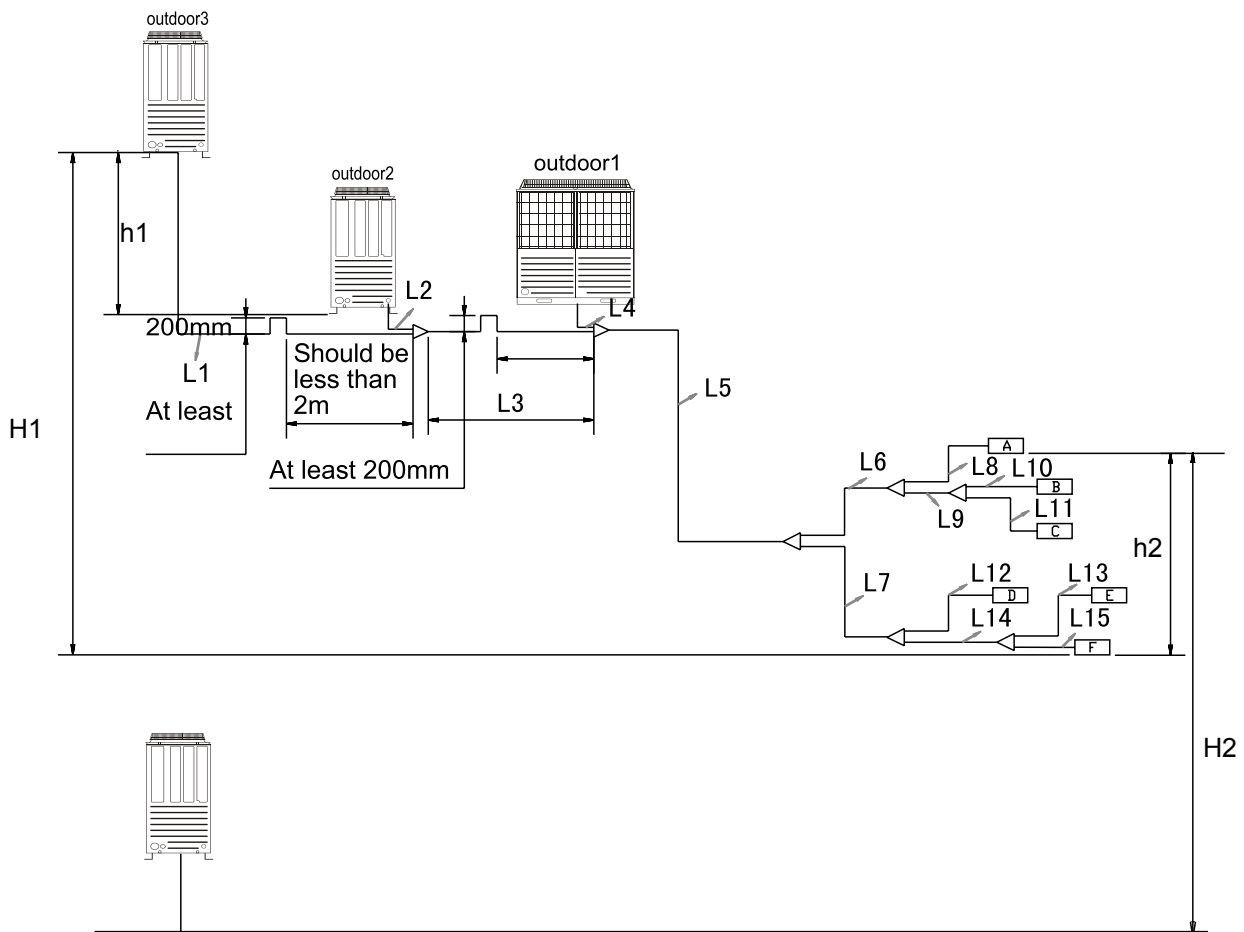

Item	Model	Length	Pipe in above figure
Single way total pipe length (=total liquid pipe length)		1000m	L1+L2+ L3+ L4+ L5+ L6+ L7+L8+ L9+ L10+L11+ L12+ L13+ L14+ L15
Single way max. pipe length (max. length between outdoor & indoor) actual length		165m	L1+ L3+ L5+ L7+ L14+ L13
Main pipe actual length (length between first gather pipe & first branch pipe)		130m	L5
Max. pipe length after first branch pipe (length between first branch & farthest indoor)		90m	L7+L13+L14
Max. pipe length between nearest indoor & farthest indoor		40m	L13+L14-L12
Max. pipe length among outdoor units (length between first gather pipe & farthest outdoor unit)		10m	L1+L3
Oil balance pipe length		10m	/
Max. height difference between indoor and outdoor	Outdoor is upper	50m	H1
	Outdoor is lower	40m	H2
Max. height difference between outdoors (in the same system)		5m (better be horizontal)	h1
Max. height difference between indoors		18m	h2

(2) Selection of pipe materials

- Interior and exterior surfaces of pipe should be clean and free of harmful sulfide, oxide, dust, grease residue and moisture (pollutant).
- Please select refrigerant pipe made of the equivalent materials as below.
- Materials: phosphorous deoxidized seamless copper pipe (C1220T-O, 1/2H, JIS H3300)
C1220T-1/2H in case outer diameter is above $\varnothing 19.05$ while C1220T-O in case outer diameter is below $\varnothing 15.88$.
- Avoid bending the pipes of $\varnothing 28.58 \times t 1.0$, $\varnothing 31.8 \times t 1.1$, $\varnothing 34.92 \times t 1.2$ and $\varnothing 38.1 \times t 1.35$ when using them.
- Thickness and specification: select them in accordance with the essentials for selection of pipe specifications. (R410A is adopted for the unit and if 0 material is used for the pipe above $\varnothing 19.05$, pressure resistance will be insufficient, so the pipe must be made of 1/2H material and be above the minimum thickness.)
- Branch and gathering pipe of the company must be used as pipe manifold.
- Refer to the operation methods for operating valve when installing it.
- When installing pipes, make sure to follow the restrictions on the maximum length, total pipe length, allowable length of pipe to the first branch pipe, allowable height difference (level difference), etc. in (1).
- When installing the branch pipe, pay attention to the installation direction and install it after reading the installation manual carefully.

(3) Selection of pipe diameter

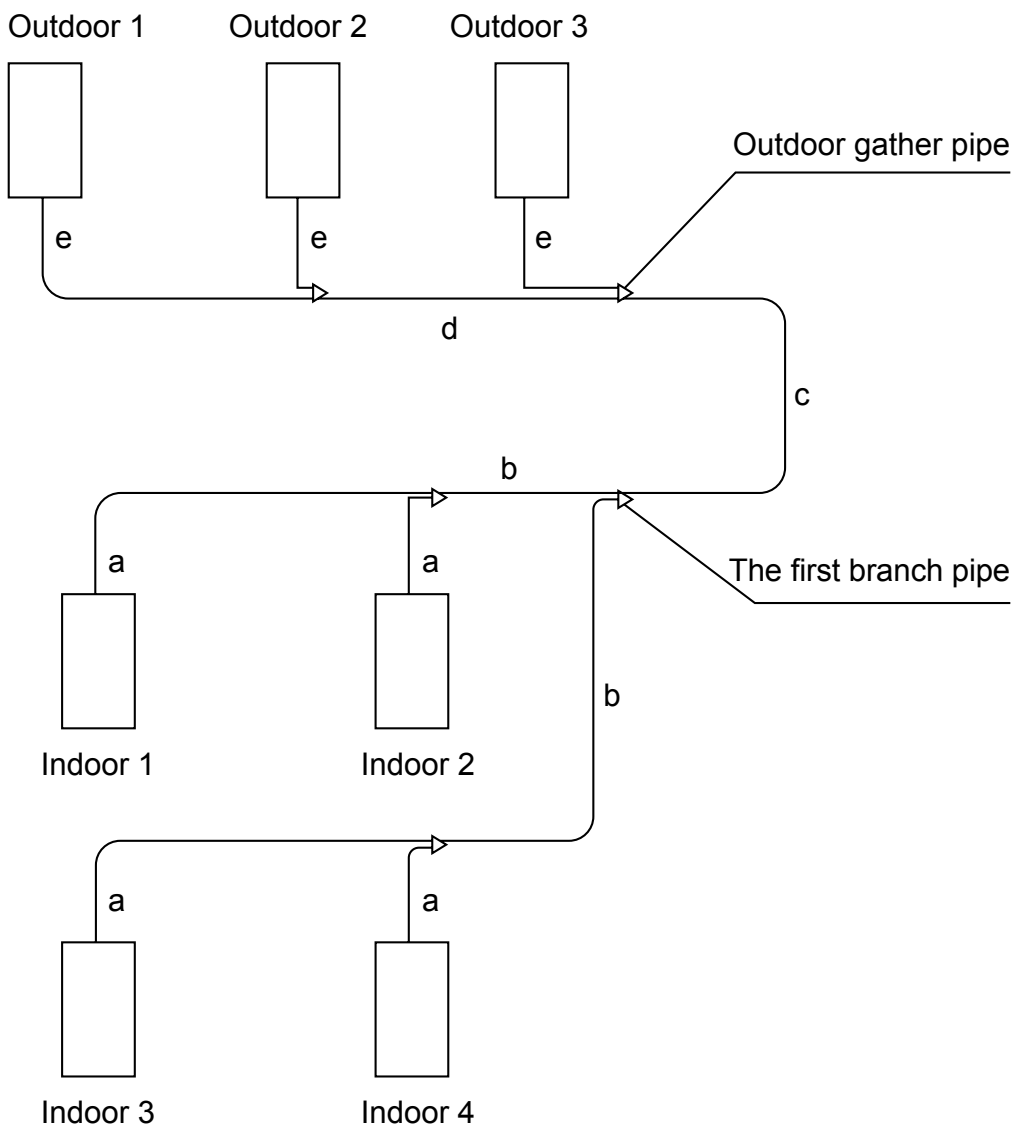

1. Pipe a (indoor-branch pipe) diameter: decided by connected indoor capacity

Indoor rated capacity (x100w)	Gas pipe	Connecting method	Liquid pipe	Connecting method	Note
15~28	9.52	Flared	6.35	Flared	
36~56	12.7		6.35		
71~140	15.88		9.52		
226~300	25.4	Braze	9.52		
450~600	28.58		12.7		

(1) When pipe length between indoor & nearest branch pipe $\geq 15\text{m}$, adjust in accordance with following criteria:

- ① If indoor rated capacity $\leq 5.6\text{kW}$, change gas / liquid pipe diameter to 15.88 / 9.52
- ② If $16.8\text{kW} \geq \text{indoor rated capacity} > 5.6\text{kW}$, change gas / liquid pipe diameter to 19.05 / 9.52
- ③ If indoor rated capacity $> 16.8\text{kW}$, change liquid pipe diameter to 12.7

(2) When pipe length between first branch pipe & farthest indoor is over 40m, pipe b (between first branch pipe & farthest indoor) should be enlarged one size.

2. Pipe b (between branch pipes) diameter:

Total capacity of connected indoors	Gas pipe	Liquid pipe	
$x < 14.1\text{kW}$	15.88	9.52	(1) Select in accordance with total capacity connected (2) Pipe b diameter should not be bigger than main pipe c If pipe b diameter is larger than main pipe c, please correct diameter according to either of the following rules: ① Reduce b diameter to be the same as pipe c ② Enlarge main pipe c diameter to be the same as pipe b. (3) If pipe b diameter smaller than pipe a, the pipe b diameter must be enlarged.
$14.1\text{kW} \leq x < 18\text{kW}$	19.05	9.52	
$18\text{kW} \leq x < 24\text{kW}$	22.22	9.52	
$24\text{kW} \leq x < 32\text{kW}$	25.4	12.7	
$32\text{kW} \leq x < 42\text{kW}$	28.58	12.7	
$42\text{kW} \leq x < 60\text{kW}$	28.58	15.88	
$60\text{kW} \leq x < 81\text{kW}$	31.8	19.05	
$81\text{kW} \leq x < 135\text{kW}$	38.1	19.05	
$135\text{kW} \leq x < 152\text{kW}$	41.3	19.05	
$x \geq 152\text{kW}$	44.5	22.22	

3. Main pipe c (between outdoor gather pipe & the first branch pipe) diameter:

Outdoor horse power	Main pipe		Enlarged main pipe	
	Gas pipe	Liquid pipe	Gas pipe	Liquid pipe
8HP	22.22	9.52	25.4	12.7
10HP	25.4	12.7	28.58	12.7
12HP	28.58	12.7	28.58	15.88
14HP	28.58	12.7	31.8	15.88
16-20HP	28.58	15.88	31.8	19.05
22-28HP	31.8	19.05	31.8	19.05
30-44HP	38.1	19.05	38.1	22.22
46-54HP	41.3	19.05	41.3	22.22
56-60HP	44.5	22.22	44.5	22.22

When the farthest length (between outdoor & the farthest indoor) is over 90m (equivalent length), the main pipe must be enlarged one size.

4. Pipe d (between gather pipes) diameter:

Total horse power of connected outdoors	Gas pipe	Liquid pipe
8HP	22.22	9.52
10HP	25.4	12.7
12HP	28.58	12.7
14HP	28.58	12.7
16-20HP	28.58	15.88
22-28HP	31.8	19.05
30-44HP	38.1	19.05
46-54HP	41.3	19.05
56-60HP	44.5	22.22

5. Pipe e (between outdoor & gather pipe) diameter:

Outdoor horse power	Gas pipe	Liquid pipe
8HP	22.22	9.52
10HP	25.4	12.7
12HP	28.58	12.7
14HP	28.58	12.7
16-20HP	28.58	15.88

Note: if the diameter between gas / liquid valve and the required connection pipe is different, please make the variable diameter pipe for connection

Since the April 17th, 2019 the factory add the reducer pipe in the accessory bag of outdoor units
The specifications of the reducer as follows:

Outdoor horse power	Gas pipe reducer	Liquid pipe reducer
8HP		
10/12/14HP	/	/
16-20HP	/	

(4) Setting of outdoor gathering pipe

Gathering pipe must be configured for outdoor combined units. (Not required in case of single unit)

Outdoor unit HP	Gathering pipe model	Remarks
22~40 HP (2 sets)	TBS-20B	2 corresponding modules
42~60 HP (3 sets)	TBS-30B	3 corresponding modules

Warning:

- (A) Please ensure that connecting pipe of outdoor unit conforms to corresponding specifications.
- (B) Please ensure that the pipe (main pipe) connected with indoor unit conforms to the specifications of main pipe marked in the next item.
- (C) Make sure to install gathering pipe (gas and liquid sides) in a strictly horizontal or vertical direction.

(5) Selection of indoor branch pipe

Selection method of branch pipe

- Branch pipe sizes vary due to different connection capacities (total downstream capacities) of indoor units, therefore, please select proper size for branch pipe.

Total capacity of indoor unit manifolds (100 W)	Model
Below 335	TAU335
Above 335 and below 506	TAU506
Above 506 and below 730	TAU730
Above 730 and below 1360	TAU1350
Above 1360	TAU2040

Warning:

- For the size of indoor unit and indoor branch pipe, please match the size of connecting pipe for indoor unit.
- Make sure to install branch pipes (gas and liquid sides) in a strictly horizontal or vertical direction.

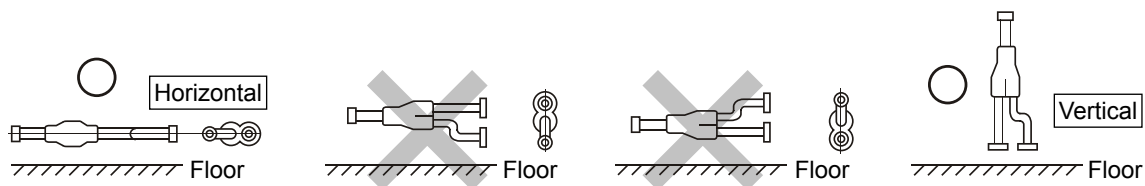

9.5.2. Pipe connecting position and removal direction

(1) Pipe connecting position and removal direction

The figure shows units with capacity below 14HP. Units with capacity above 16HP share the same pipe connecting position and removal direction only except for height. Size in [] is for units with capacity above 16HP.

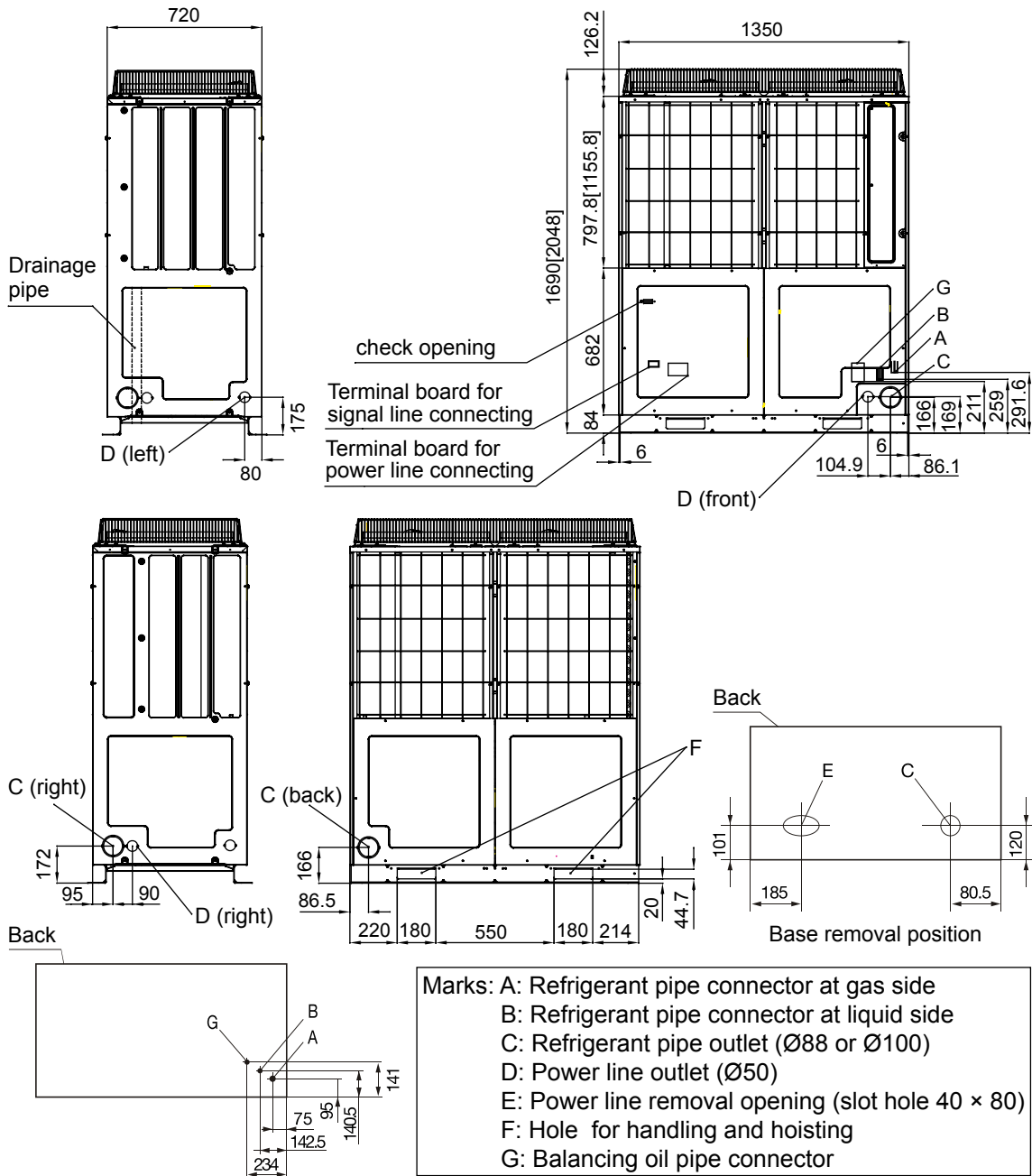

Connector size of refrigerant pipe (plane graph)

Balancing oil pipe of connect G is only for outdoor combined units. (Not required in case of single unit.)

- As shown in the figure above, the pipe can be removed from the front, the right, the bottom and the back.
- When connecting pipes on site, use a wrench to sever the semi-finished through hole on the outer plate (ø88mm or ø100mm).
- Please use a stopper (provided on site) to plug the pipe outlet in order to prevent entry of small animals, etc.
- Please connect pipe and operating valve with corner joints (provided on site).
- As shown in the figure below, when fixing pipe on site, please set pipe fixing position more than 1.5 m distant from outdoor unit. (Otherwise, pipe may be broken sometimes due to various anti-vibration methods).

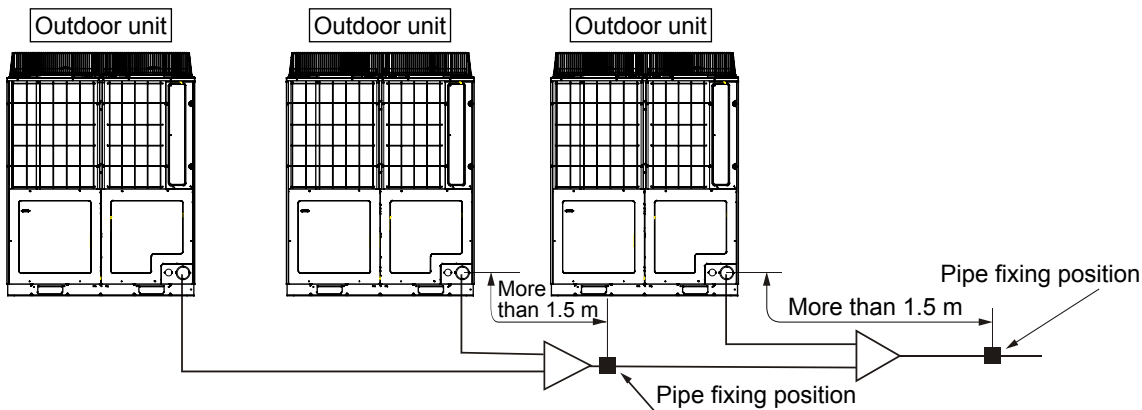

(2) Pipe construction

Important notes

- Prevent collision between pipe under construction and components inside unit.
- When conducting pipe construction on site, please turn off operating valve completely.
- It is necessary to protect pipe ends (by welding them after squashing or by wrapping them tightly with tape), to prevent entry of moisture and foreign substances.
- Try to bend pipe around a large radius (more than four times the pipe diameter). Do not repeat bending.
- Use bell mouth to connect outdoor unit liquid pipe and liquid refrigerant pipe. Please install flared nut on the pipe to conduct flaring. The flaring method for R410A differs from the previous one for R407C. Flaring tool for R410A is appropriate, but the previous tools will be still available if copper pipe gauge for adjustment of exposed length is used to adjust exposed length B.
- Ester oil is proposed as flaring oil so as to adapt to unit type of R410A refrigerant.
- During connection for pipe flaring, please tighten the pipe with double wrenches. Refer to the following values for tightening torque of the flared nut.

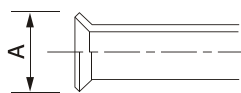

Flared pipe head: A (mm)

Outer diameter of copper pipe	A
	0 -0.4
Ø6.35	9.1
Ø9.52	13.2
Ø12.7	16.6
Ø15.88	19.7

Attention

Absent use of double wrenches for fastening may lead to deformation of operating valve, causing entry of nitrogen into outdoor unit.

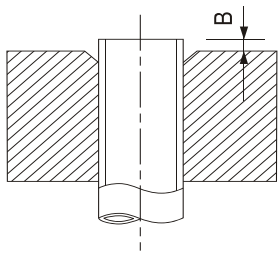

Exposed length of copper pipe when flaring pipe: B (mm)

Outer diameter of copper pipe	For rigid pipe (clutch-type)	
	When using the R410A special tool	When using the previous tool
Ø6.35	0-0.5	0.7-1.3
Ø9.52		
Ø12.7		
Ø15.88		

For operating valves at liquid and gas pipe sides, fix the main valve body and install as per a proper tightening torque as shown in the figure above.

Size of operating valve (mm)	Tightening torque (N·m)	Angle of tightening torque (°)	Suggested arm length of tool (mm)
Ø6.35 (1/4")	14~18	45~60	150
Ø9.52 (3/8")	34~42	30~45	200
Ø12.7 (1/2")	49~61	30~45	250
Ø15.88 (5/8")	68~82	15~20	300
Ø19.05 (3/4")	100~120	15~20	450

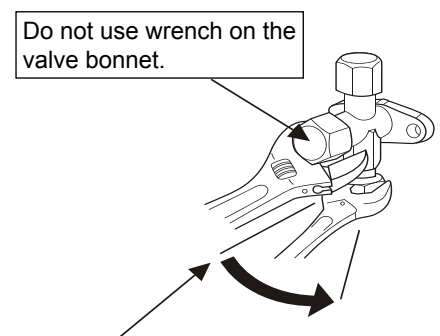

Use torque wrench. If there is no torque wrench, screw the tapered nut tightly with hands before tightening it according to the standards shown above.

- When connecting flared pipe, don't apply oil on the flared part.
- Adopt brazing for connecting outdoor unit gas pipes with refrigerant pipes and refrigerant pipe with branch pipes.
- It is necessary to charge nitrogen while welding. Otherwise, a mass of foreign substance (oxidized film) will be generated to block capillary tube and expansion valve, thus causing lethal fault.
- While welding operating valve with pipe, cool down the valve body with wet towel at the same time.
- Please rinse pipe. During rinsing, charge nitrogen into the pipe with the pressure around 0.02 MPa while blocking the pipe ends with hand until pressure rises inside the pipe. (At the same time, plug other pipe ends.)

Operating sequence

- ① Under pipe construction on site, turn off the operating valve completely.
- ② It is necessary to fill nitrogen while welding. Otherwise, a mass of foreign substance (oxidized film) will be generated to block capillary tube and expansion valve, thus causing lethal fault.

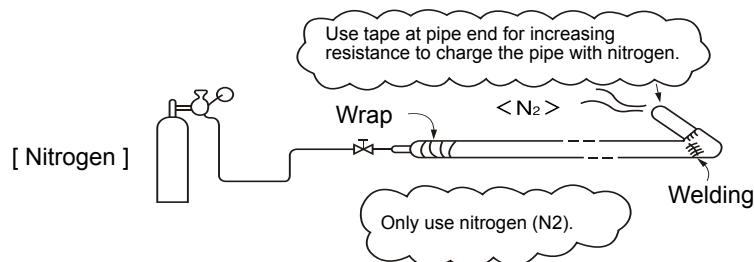

- ③ It is necessary to protect pipe ends (by welding them after squashing or wrapping them tightly with tape), to prevent entry of moisture and foreign substances.

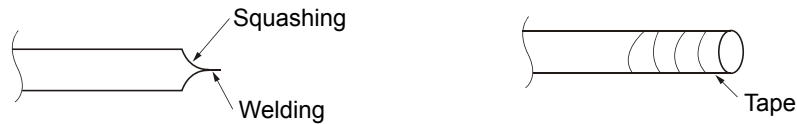

- ④ Please rinse pipe. During rinsing, charge nitrogen into the pipe with pressure around 0.02 MPa while blocking the pipe ends with hand until pressure rises inside the pipe. (At the same time, plug other pipe ends.)

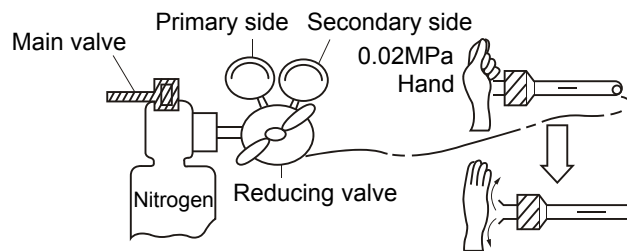

- ⑤ When welding operating valve with pipe, cool down the valve body with wet towel at the same time.

3. Airtight test and vacuum suction

(1) Airtight test

- ① The Company has completed airtight test of outdoor unit. After pipes are connected, airtight test on connecting pipe and indoor unit will be conducted through the check interface of the outdoor operating valve. Besides, it is necessary to turn off the operating valve during the airtight test.
- ② To conduct airtight test by pressurizing the refrigerant pipe to design pressure of the product via nitrogen, use connecting devices shown as below. Never use chlorine refrigerant, oxygen or any inflammable gas as pressurizing gas.
Never open the closed operating valve.
Pressurize all liquid, gas and balancing oil pipes.
- ③ Instead of pressurization once for all, perform it slowly to the specified pressure.
- (A) Raise pressure to 0.5 MPa and then stop pressurization, leave it alone for more than 5 minutes to confirm whether the pressure falls.
- (B) Further raise the pressure to 1.5 MPa and then stop pressurization, leave it alone for more than 5 minutes to confirm whether the pressure falls.
- (C) Raise the pressure to the designated value (4.15 MPa) and record the ambient temperature and pressure.
- (D) Leave it alone at the designated value for more than 1 day, and if the pressure does not fall, air-tightness is qualified.
At this time, when ambient temperature changes by 1°C, the pressure will change by around 0.01 MPa as well. Therefore, rectification is required.

(E) Upon confirmation via the procedures from (A) to (D), if the pressure is low, the leakage exists. Check welding part, flaring part, etc. with foam test solution, find out leakage and repair it. Test the airtightness again after the repair.

Attention

Prevent excessive pressurizing, or nitrogen may access outdoor unit.

④ Make sure to conduct vacuum pumping after the airtight test.

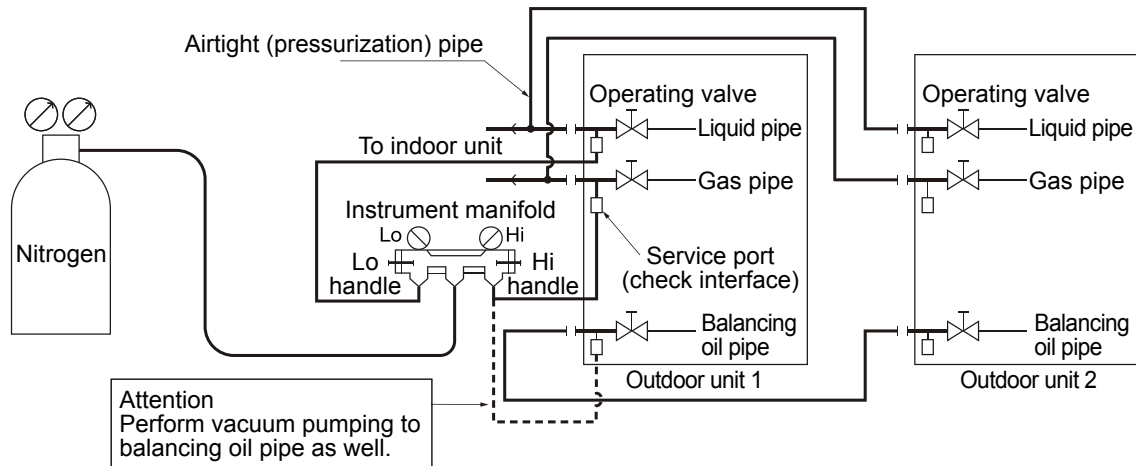

(2) Vacuum pumping

Carry out vacuum pumping from the check interface of operating valve at liquid side and from both sides of operating valve at gas side. Make sure to perform vacuum pumping for balancing oil pipe as well. (Use the check interface of balancing oil pipe's operating valve separately.)

<Workflow>

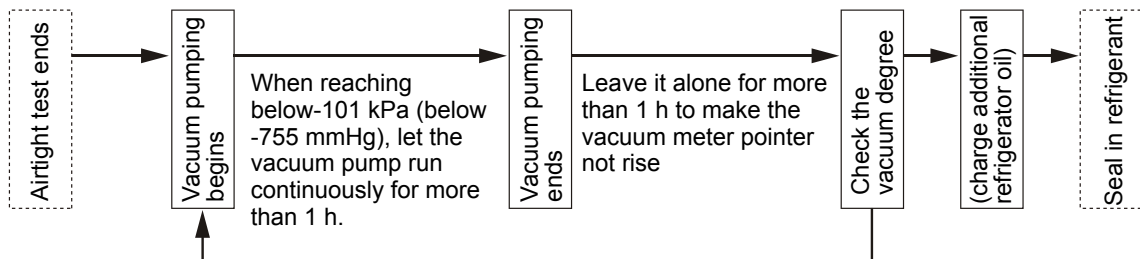

A rising vacuum meter pointer indicates there is residual moisture or water leakage inside the system. Check and repair the leakage part before another vacuum pumping.

Attention

When vacuum degree is insufficient, blockage will result from inadequate capacity, residual moisture, etc., thus leading to compressor fault.

As R410A refrigerant is adopted for the unit, the following matters will be noted:

- Use special tools of different refrigerants to avoid mixture with different kinds of oil. Especially for instrument collector and filling hose, never share tools with other refrigerants (R22, R407C, etc.).
- Use anti-backflow adaptor to prevent air, compressor oil from mixing the cooling cycle.

(3) Charge additional refrigerant oil

When total pipe length is more than 510 m, shake the gas pipe after vacuum suction.
Charge additional 1000 cc FV50S refrigerant oil from the joint.

(4) Operating method of operating valve

Opening/closing method

- Remove the valve bonnet and turn the gas pipe side to "on".
- Rotate the liquid pipe side and the balancing oil pipe side with hexagon wrench (JISB4648) until the axle stops. Since opening the valve violently may damage it, it is necessary to use special tool.
- Fasten the valve bonnet.

Refer to the table below for tightening torque.

	Tightening torque N·m		
	Axle (valve body)	Bonnet (cover)	Cap nut (for check joint)
For gas pipe	Below 7	Below 30	13
For liquid gas	7.85 (MAX 15.7)	29.4 (MAX 39.2)	8.8 (MAX 14.7)
For balancing oil pipe	4.9 (MAX 11.8)	16.2 (MAX 24.5)	8.8 (MAX 14.7)

Refer to 2- (2) on-site pipe construction for tightening torque of tapered nut.

9.5.4. Seal in the charged additional refrigerant

Seal in the charged additional refrigerant in liquid state.

Make sure to use gauge for refrigerant sealing-in.

If the refrigerant cannot be completely sealed in when outdoor units are out of service, sealing in on test run mode will be conducted. (Refer to item for test run method.)

Insufficient refrigerant and long-term running will lead to compressor fault. (Especially when unit running and refrigerant sealing-in are simultaneous, they must be completed within 30 minutes.)

Determine sealing-in quantity of the additional refrigerant as per the calculation method below and record the additional quantity of charged refrigerant on the refrigerant quantity recording board on the back of front panel.

The unit is charged only part of the refrigerant at the factory, also need additional refrigerant at the installation site.

W1: Refrigerant charging volume to outdoor unit at factory.

W2: Refrigerant charging volume to outdoor unit on site.

W3: Refrigerant charging volume to liquid pipe base on different piping length calculation.

W3=actual length of liquid pipe×additional amount per meter liquid pipe

=L1×0.35+L2×0.25+L3×0.17+L4×0.11+L5×0.054+L6×0.022

L1: Total length of Ø22.22mm liquid pipe (m);
 L2: Total length of Ø19.05mm liquid pipe (m);
 L3: Total length of Ø15.88mm liquid pipe (m);
 L4: Total length of Ø12.7mm liquid pipe (m);
 L5: Total length of Ø9.52mm liquid pipe (m);
 L6: Total length of Ø6.35mm liquid pipe (m);
 Total refrigerant volume charging on site during installation=W2+W3
 W: Total refrigerant volume charging on site for maintenance.

Refrigerant record form						
Model	W1: Refrigerant charging volume to outdoor unit at factory	W2: Refrigerant charging volume to outdoor unit on site	W3: Refrigerant charging volume to liquid pipe base on different piping length calculation		Total refrigerant volume charging on site during installation	W: Total refrigerant volume charging on site for maintenance
			Liquid pipe diameter (mm)	Additional refrigerant amount (kg)		
AW-YDV250HT-H16	9.7kg	0kg	Ø6.35	0.022kg/m×__m=__kg	W2+W3=____kg	W1+W2+W3=____kg
AW-YDV280HT-H16	9.7kg	0kg	Ø9.52	0.054kg/m×__m=__kg		
AW-YDV335HT-H16	10kg	1kg	Ø12.7	0.11kg/m×__m=__kg		
AW-YDV400HT-H16	10kg	3kg	Ø15.88	0.17kg/m×__m=__kg		
AW-YDV450HT-H16	10kg	10kg	Ø19.05	0.25kg/m×__m=__kg		
AW-YDV504HT-H16	10kg	10kg	Ø22.22	0.35kg/m×__m=__kg		
AW-YDV560HT-H16	10kg	10kg	W3=____kg			

Important notes

Separate the refrigerant system when exceeding values in the table below in terms of filling quantity of refrigerant pipe.

Outdoor unit	Additional sealing-in quantity (kg)
8HP~20HP	50
22HP~40HP	100
42HP~60HP	150

As R410A refrigerant is adopted for the unit, the following matters will be noted:

- Use special tools of different refrigerants to avoid mixture with different kinds of oil. Especially for instrument collector and filling hose, never share tools with other refrigerants (R22, R407C, etc.).
- Mark different colors on refrigerant tanks to indicate the refrigerant types (pink for R410A) and ensure there is no error.
- Never use charging cylinder. Refrigerant composition may be changed when R410A is transferred to the cylinder.
- When charging the refrigerant, make sure to take it out of refrigerant tank in liquid form.

Warning:

Record the refrigerant quantity calculated as per the pipe length on the refrigerant quantity recording board on the back of front panel.

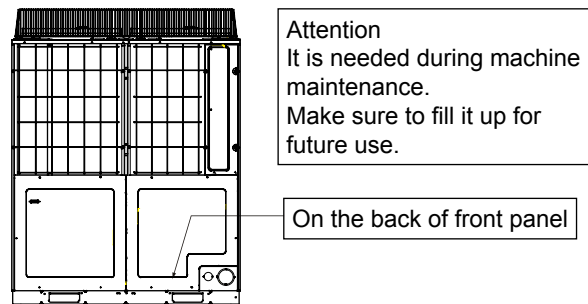

9.5.5. Heat insulation and dew prevention

- ① Carry out dewing prevention and heat insulation on refrigerant pipe (all gas, liquid and balancing oil pipes). Improper measures for dewing prevention and heat insulation will cause water leakage, dewing and moistening other indoor articles.
- ② Use heat insulation materials with heat resistance above 120°C. The low heat resistance will cause poor heat insulation and wire deterioration.
 - (A) During refrigerating, make sure to prevent condensed water on the pipe from accumulating and further inducing water leakage. And in the process of heating, the pipe's surface temperature increases due to flowing of exhaust gas, the person may get burned when touching it. Therefore, it is necessary to carry out heat insulation.
 - (B) Conduct heat insulation with heat insulation material (pipe casing) to the flaring joint of indoor units. (Conduct heat insulation to both gas and liquid pipes.)
 - (C) Carry out heat insulation to gas side and liquid side at the same time. In order to fit pipe closely with heat insulation material, wrap it up with outer packaging tape along with connecting wire.
 - (D) The air conditioner has been tested and proved to be a qualified product in dewing condition as regulated in JIS. However, dripping may occur in the environment of high humidity (with dew point temperature above 23°C). In this case, additional 10-20 mm heat insulation material will be applied on indoor main units, the pipe and drainage pipe.
 - (E) In case of ambient dew point temperature above 28°C or relative humidity above 80%, apply additional 10~20 mm heat insulation material.

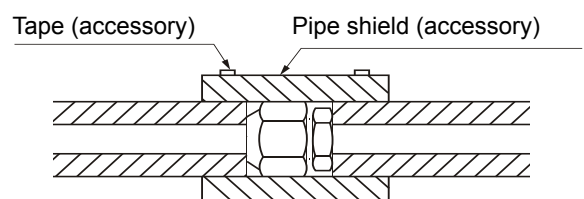
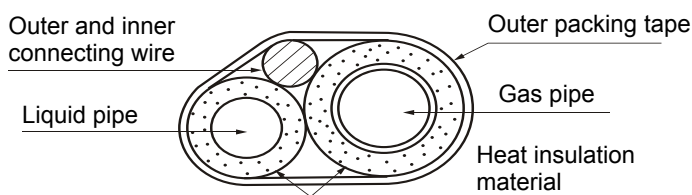

9.6 Discharge pipe works

- For the parts with drainage problems in outdoor units, please use separately sold discharge pipe and metal ring in discharge pipe construction.

Electrical wiring should be conducted by construction organization recognized by electric power company. Please conduct electrical construction according to Relevant Technological Fundamentals of Electrical Equipment and Local domestic law.



To prevent electric shock and fire accident, please set leakage protector.

(The unit is equipped with frequency converter, therefore, to prevent misoperation of leakage protector, please adopt non-operational shock wave type of leakage protector)

Warning:

- (A) Don't use wires other than copper ones.
Besides, don't use power wires with grade lower than the following ones.
 - Rubber insulated shielded wire with standard toughness (wire name: 60245 IEC 53)
 - Standard PVC insulated shielded wire (wire name: 60227 IEC 53)
 - Don't use wires with weather fastness lower than that of the flexible neoprene shielded wire (design 245 IEC 57) as power wire for outdoor unit parts.
- (B) Indoor and outdoor units should be respectively set with their own independent power supply.
- (C) Power supply for all the indoor units in a system should be ensured to be simultaneously connected and disconnected.
- (D) The units should be grounded. While the ground wire should not be connected to that of gas pipe, water pipe, lightning rod, or telephone lines. Any improper grounding may lead to electric shock or fire.
- (E) Non-operational shock wave type of leakage protector must be installed. Otherwise, it may cause electric shock and fire accidents. Power supply should not be connected before installation, and maintenance should be conducted after the power supply is disconnected.
Besides, if ground wire is connected with gas pipe, explosion and fire may happen when the gas leaks.
- (F) Never install phase capacitor for power factor improvement. (It cannot improve the power factor and may cause abnormal overheating accident.)
- (G) Please use wire tube for power supply wiring.
- (H) In case of wiring outside the unit, please do not put wire of low current (remote controller and signal wire) and that of other heavy currents through the same place. Otherwise the effect of electrical noise may lead to misoperation.
- (I) Power supply wire and signal wire must be connected to power supply wiring board. Please fix them with wiring fixing clamp inside the unit.
- (J) Prevent the wire touching the pipe during fixing.
- (K) After connection of wires, please make sure the connector or terminal of electrical components in the instrument box do not fall off and then install the box cover firmly. (If immersed in water due to improper installation, it may cause misoperation and fault.)
- (L) Please use circuit breaker with correct capacity (leakage circuit breaker and line circuit breaker). If you use circuit breaker with a large capacity, fault, fire, etc. may be induced.

9.6.1. Wiring system diagram

(Combined unit)

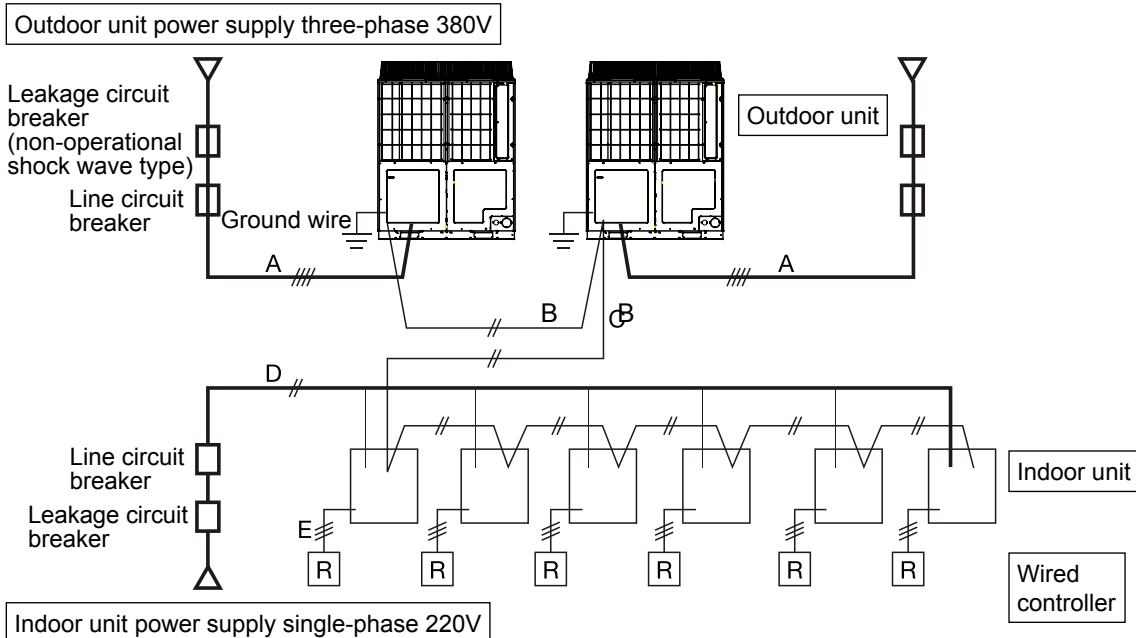

- A: Power supply wire (main power supply wire) [4-core]
- B: Signal wire (outdoor-outdoor Signal wire) [3-core]
- C: Signal wire (hyper connected wire) [2-core]
- D: Power supply wire (indoor power supply wire) [2-core]
- E: Wired controller wire [3-core]

Note: In case leakage protector is exclusive for ground protection, another protector shall be set for wiring.

9.6.2. Essentials in power supply wire connection

(1) Wire removal method

- As shown in Figure 2-(1) in Page 16, the wire can be removed from the front, the right, the left and the bottom.
- When connecting the wire on site, please cut off the semi-finished through hole on the outer plate by a wrench (hole of $\varnothing 50\text{mm}$ or slot hole of $40\text{mm} \times 80\text{mm}$ dimension)

(2) Attentions during connection of power supply wires

Power supply wires should be connected to power supply wiring board and fixed outside electrical box. When connecting to power supply wiring board, please use rounded compression joint.

- Ground wires should be connected before connection of power supply wire. Besides, when connected to the terminal board, the ground wire should be longer than the power supply wire and be free from bearing tension.
- Never connect power supply before completion of the works. Conduct maintenance after cutting off the power supply.

- Ground wires should be connected correctly (grounded).
- Power supply wire should be connected to power supply terminal board.
- When connected to the power supply terminal board, rounded compression terminal should be adopted.
- Particular wire should be used for connection in wiring. And external force should not be applied on the joint during fixing.
- Please use proper screwdriver to tighten screws on the binding post. Refer to the below table for tightening torque of relevant terminal.
If the screws on binding post are tightened excessively, the screws may be broken.
- After completion of the power supply works, please make sure all the connectors and terminals of electrical components in the instrument box do not fall off.

Tightening torque (N m)		
M4	Terminal for signal wire	0.9~1.2
M5	Terminal and ground wire for power supply	2.00~2.35

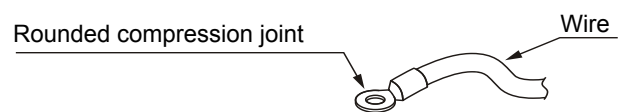

(3) Specifications of outdoor unit power supply: three-phase power supply of 380V and 50/60Hz

Model	Item	Power supply	Minimum cross section area of power wire (mm ²)	Wiring length (m)	Circuit breaker (A)	Rated current of leakage circuit breaker (A) Leakage current (mA) Operation time (s)	Ground wire	
							Load area (mm ²)	Screw type
Independent power supply	AW-YDV250HT-H16	3PH, 380V, 50/60 Hz	10	92	40	40A, 100mA, below 0.1s	5.5	M6
	AW-YDV280HT-H16		10	92	40	40A, 100mA, below 0.1s	5.5	M6
	AW-YDV335HT-H16		16	92	50	50A, 100mA, below 0.1s	5.5	M6
	AW-YDV400HT-H16		16	92	60	60A, 100mA, below 0.1s	5.5	M6
	AW-YDV450HT-H16		25	92	80	80A, 100mA, below 0.1s	5.5	M6
	AW-YDV504HT-H16		25	92	80	80A, 100mA, below 0.1s	5.5	M6
	AW-YDV560HT-H16		25	92	80	80A, 100mA, below 0.1s	5.5	M6

- Power wire of outdoor unit should be well fixed and connected by rounded compression joint. It is strictly prohibited to be connected to line bank.
- All the outdoor units should be grounded.
- Power wire should be thickened if its length is out of range.

(4) Specifications of indoor unit power supply: single-phase 220V and 50/60Hz

Total current of indoor units (A)	Item	Minimum cross section area of power wire (mm ²)	Wiring length (m)	Rated current of overcurrent circuit breaker (A)	Rated current of leakage circuit breaker (A) Leakage current (mA) Operation time (s)	Cross section area of signal wire	
						Outdoor-indoor (mm ²)	Indoor-indoor (mm ²)
<10		2	23	20	20A, 30 mA, below 0.1 s	2-core×0.75-2.0 shielded wire	2-core×0.75-2.0 shielded wire
≥10 and <15		3.5	24	30	30A, 30 mA, below 0.1 s		
≥15 and <22		5.5	27	40	40A, 30 mA, below 0.1 s		
≥22 and <27		10	42	50	50A, 30 mA, below 0.1 s		

- Power wire and signal wire should be well fixed.
- All the indoor units should be grounded.
- Power wire should be thickened if its length is out of range.
- All the shielding layers of signal wire should be connected together with one end grounded.
- Total length of signal wire should not be more than 1000 m.

9.6.3. Essentials in signal wire connection

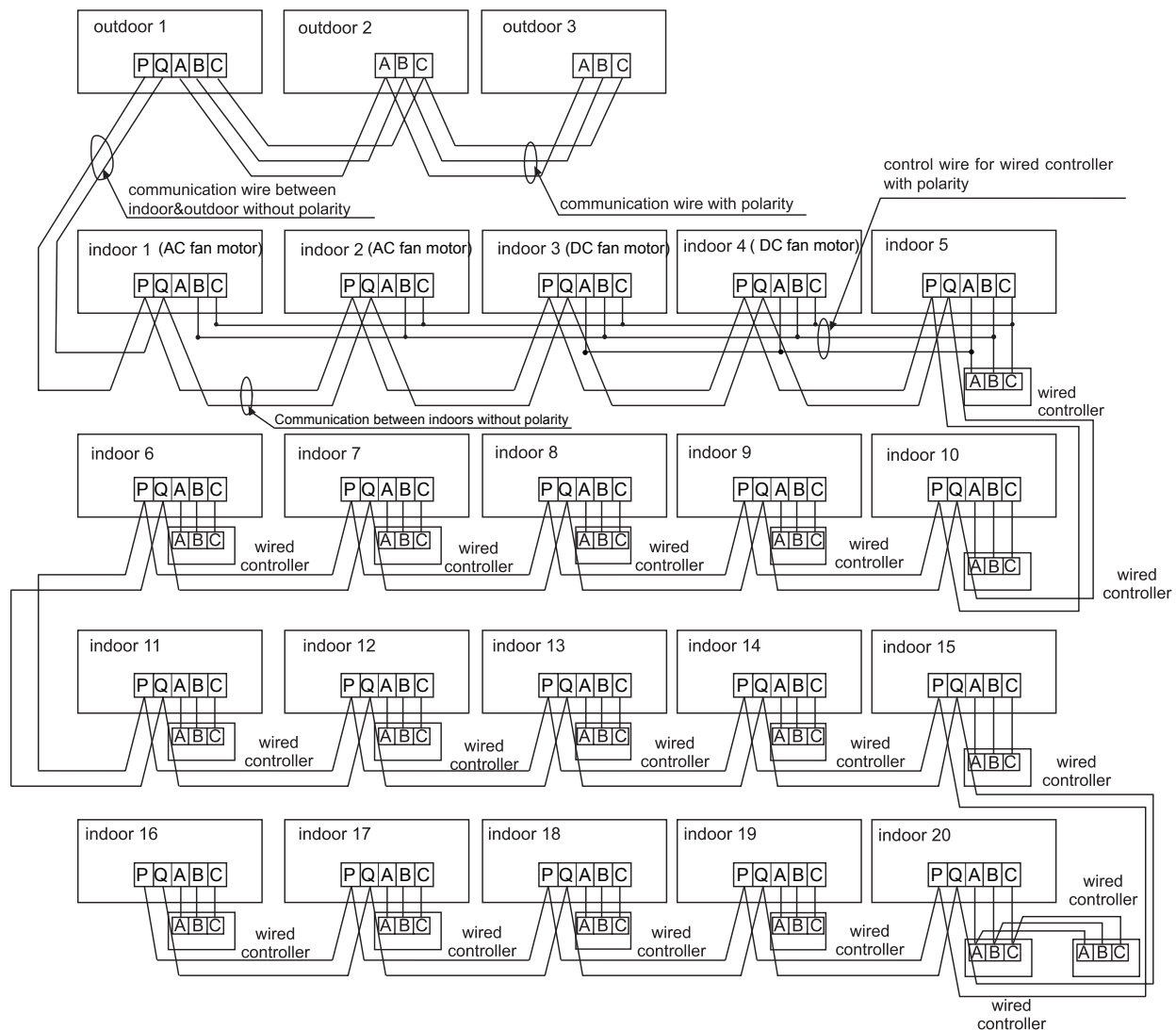

Outdoor units are of parallel connection via three lines with polarity. The master outdoor and all indoor units are in parallel through 2 non-polar wires.

There are three connecting ways between wired control and indoor units:

- A. One wired controller controls multiple units, as shown in the above figure, (1-5 indoor units). The indoor unit 5 is the wired control master unit (directly connected to the indoor unit of wired controller) and others are the wired control slave units. 3 and 4 indoor units are DC fan motor models, 1 and 2 indoor units are the AC fan motor models. The wired controller is connected with the master unit and DC fan motor models through three lines with polarity. Other indoor units and the master unit are connected via two lines with polarity. SW01 on the main unit is set to 0 while SW01 on other slave units are set to 1, 2, 3 and so on in turn. (Please refer to the dip switch setting)
- B. One wired controller controls one indoor unit, as shown in the above figure (indoor unit 6-19). The indoor unit and the wired controller are connected via three lines with polarity.
- C. Two wired controllers control one indoor unit, as shown in the figure (indoor unit 20). Either of the wired controllers can be set to be the master wired control while the other is set to be the slave wired controller. The master wired controller, slave wired controller and indoor units are connected via three lines with polarity.

Type	Series	Model	PCB Code
AC fan motor	4-way Cassette	AWSI-CBV***-N11	0151800113
		AWSI-CCV***-N11	0151800161B
	2-way Cassette	AWSI-CEV***-N11	0151800161B
	Convertible	AWSI-FAV0***-N11	0151800113
	Slim Low ESP Duct	AWSI-DDV***-N11	0151800161C
	Medium ESP Duct	AWSI-DBV***-N11	0151800113
		AW-DBV***-N11	0151800161C 0151800161G
High ESP Duct	AWSI-DCV***-N11	0151800113	
DC fan motor	Round Flow 4-Way Cassette	AWSI-CFV***-N11	0151800227
	One Way Cassette	AWSI-CDV***-N11	0151800244BA
	Console	AW-EAV***-N11	0151800452
	N Plate High Wall	AWSI-HBV***-N11	0151800244B

Note:

- 1) All the wires, parts and materials purchased on site should conform to the local laws and those of the host country.
- 2) Only copper conductor can be adopted.
- 3) Line circuit breaker should be installed for sake of safety.
- 4) All on-site wiring and devices should be in the charge of certified electricians.
- 5) Air conditioner should be grounded according to requirements of local laws and those of the host country.
- 6) The wiring diagram shows only general connection points, excluding installation details with special requirements.
- 7) All the equipment sets should be equipped with switch and fuse for power circuit installation.
- 8) Since the system consists of multipoint power supply connected equipment, power supply of all the equipment sets can be switched with centralized approach after installation of main switch.

Wired controller signal wiring

Wire length (m)	Wire spec
≤ 250	0.75mm ² ×(3-core) shielded wire

Shielded layer of communication wire must be grounded at one end.
The total length cannot exceed 250m.

10. Branch Pipe Dimensions

Unit: mm ID: inner diameter OD: outer diameter

Model	Gas side branch pipe	Liquid side branch pipe	Gas side connection of branch pipe	Liquid side connection of branch pipe
TAU335				
TAU506				
TAU730				

Model	Gas side branch pipe	Liquid side branch pipe	Gas side connection of branch pipe	Liquid side connection of branch pipe
TAU1350				
TAU2040				

11. Gather Pipe Dimension

Gather pipe is used for combination of outdoor unit. TBS-20B (for 2 basic modules); TBS-30B (for 3 basic modules). Unit: mm, ID: inner diameter; OD: outer diameter. Note: Cut off the pipe from its middle when using

Model	Side	Mark	Gather pipe	Connection of gather pipe
TBS20	Suction gas side	(A)		
	Liquid side	(B)		
TBS30	Suction gas side	(C)		
		(D)		
	Liquid side	(E)		
		(F)		

12. Trial Operation

12.1 Confirmation by electrifying

Before the outdoor unit is powered on for the first time, the first and second bit (BM1-1, BM1-2) of dip switch code BM1 of the outdoor unit PCB board should be turned to OFF. Power supply for outdoor and indoor units should be checked according to the table below.

No.	Contents to be confirmed	Result
1	Whether there is power on interface board of the outdoor unit, whether the digital tube is displaying and whether the displayed data on dip switch panel and the tube are variable.	
2	For VRF outdoor unit, indoor unit number displayed on the digital tube is consistent with the actual number when dip switch panels SW9, SW10 and SW11 are turned to "0 3 2", and dip switch code BM1-2 is turned from OFF to ON.	
3	For VRF outdoor unit system, outdoor unit number displayed on the digital tube is consistent with the actual number when dip switch panels SW9, SW10 and SW11 are turned to "0 2 2", and dip switch code BM1-1 is turned from OFF to ON.	
4	For VRF outdoor unit system, the HP of outdoor unit sets displayed on the digital tube is consistent with the actual unit type when dip switch panels SW9, SW10 and SW11 are turned to "0 1 2" AW-YDV250HT-H16 shows "8.0" AW-YDV280HT-H16 shows "10.0" AW-YDV335HT-H16 shows "12.0" AW-YDV400HT-H16 shows "14.0" AW-YDV450HT-H16 shows "16.0" AW-YDV504HT-H16 shows "18.0" AW-YDV560HT-H16 shows "20.0"	
5	Check whether the parameters, such as parameters of outdoor unit sensors, number of indoors connected and the opening of electronic expansion valves, etc., are correct through dip switch on the outdoor unit interface board or by using testing equipment and computer software.	
6	Check whether the parameters, such as parameters of indoor unit sensors, the opening of electronic expansion valves, etc., are correct through dip switch on the outdoor unit interface board or by using testing equipment and computer software.	

Note:

If the indoor unit cannot be searched or the number of the searched units isn't consistent with the actual number of indoor units in the system within four and a half minutes, it will be reported as communication fault 26-X.

12.2 Rated operation

Startup control on indoor and outdoor units and operation condition inspection for outdoor units can be completed through rated operation. In case of inspection on single indoor unit, wired controller or remote controller of indoor unit will be adopted for control.

Rated cooling operation: when SW9, SW10 and SW11 dip switches are turned to 0, 13, 2, the indoor units will be started up automatically and be forced to turn to cooling operation.

Rated heating operation: when SW9, SW10 and SW11 dip switches are turned to 0, 14, 2, the indoor units will be started up automatically and be forced to turn to heating operation.

12.3 Trial operation confirmation

The test run confirmation, in principle, shows that all the indoor units should be confirmed one by one. The improper connection of refrigeration pipe and control wire cannot be confirmed when all the indoor units are running simultaneously. So all the other indoor units should be set in "stopped condition".

A. Main power supply and initial confirmation

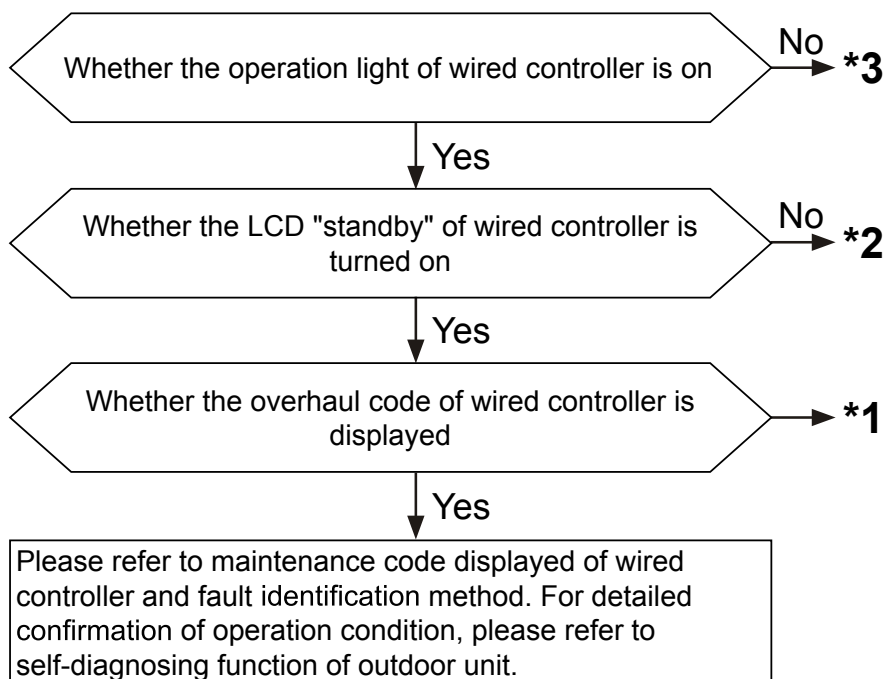

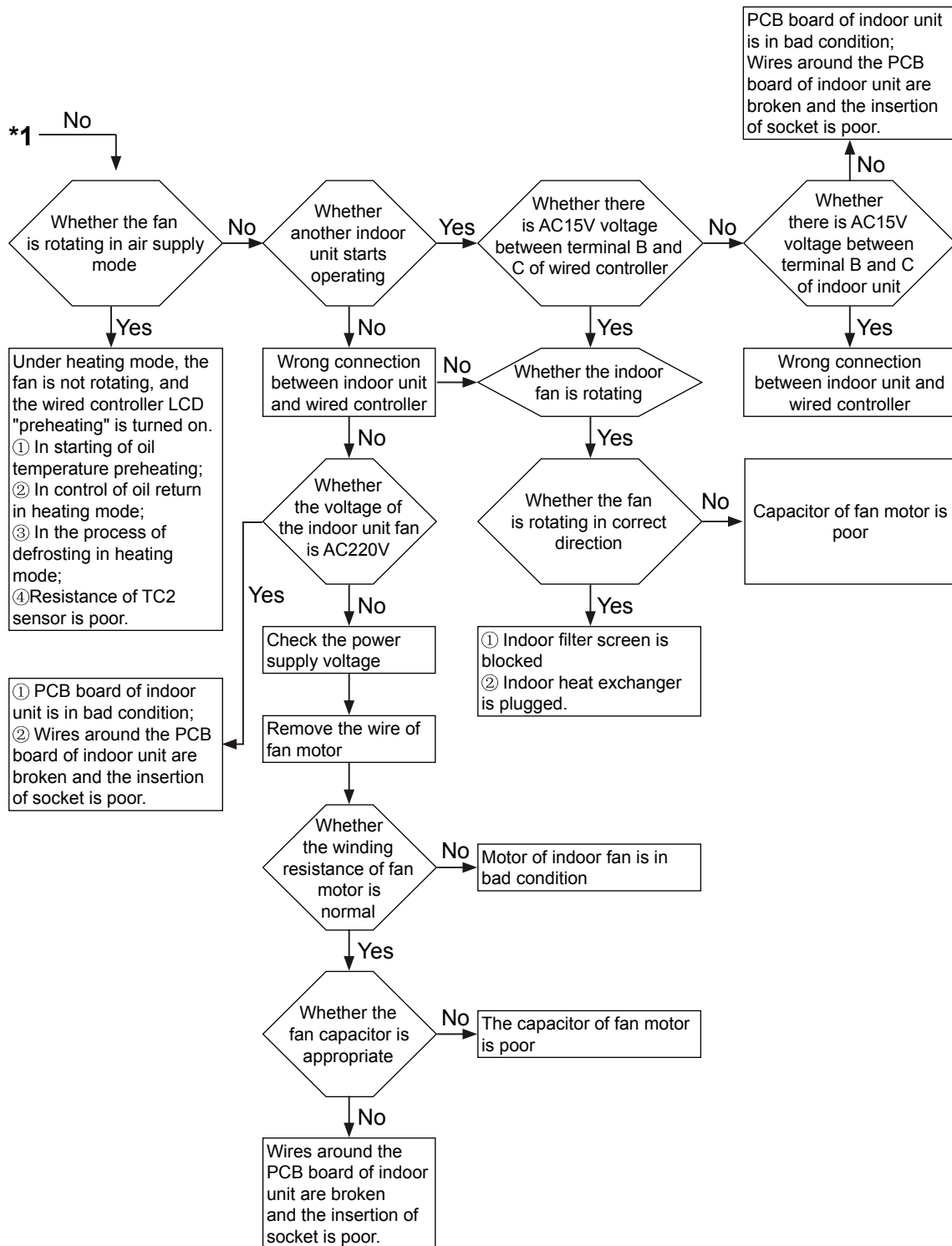

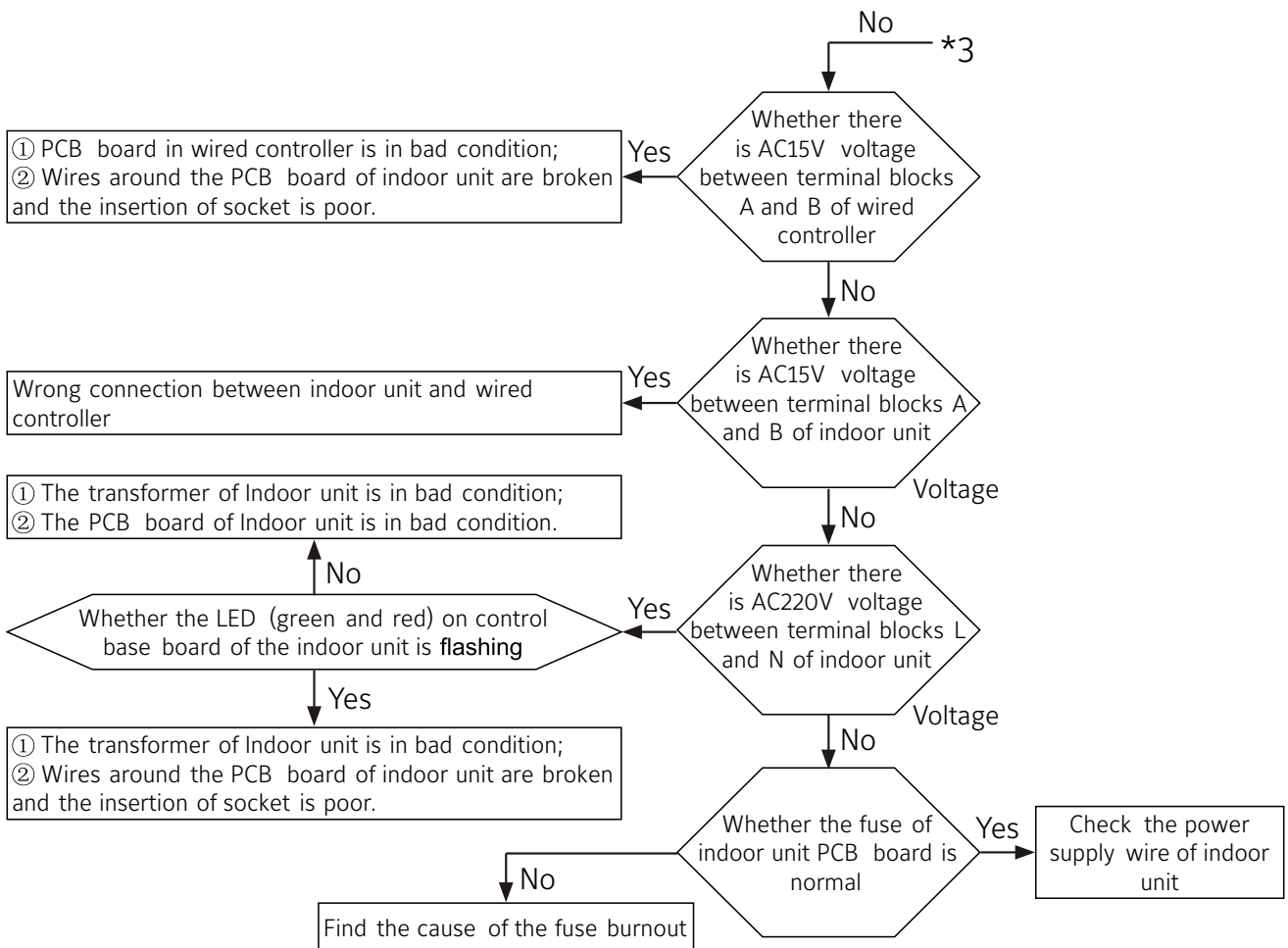
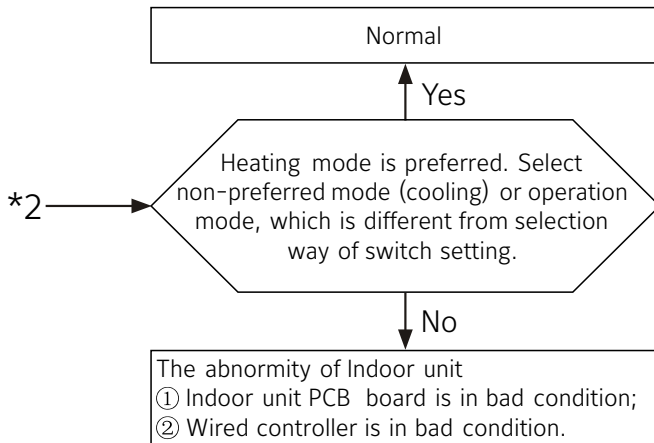

B. Air blower operation confirmation

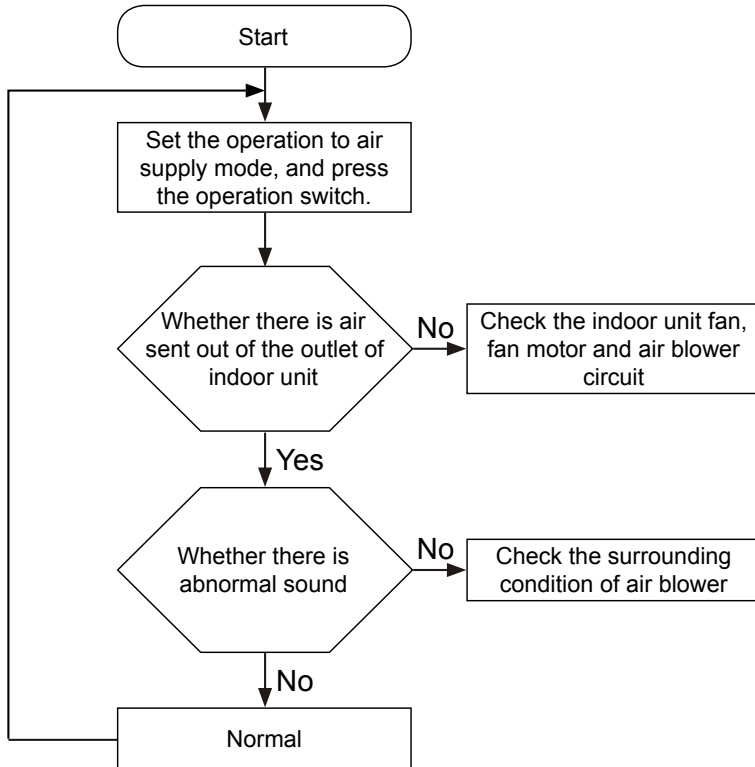

Note: Check the indoor units one by one.

C. Cooling operation confirmation

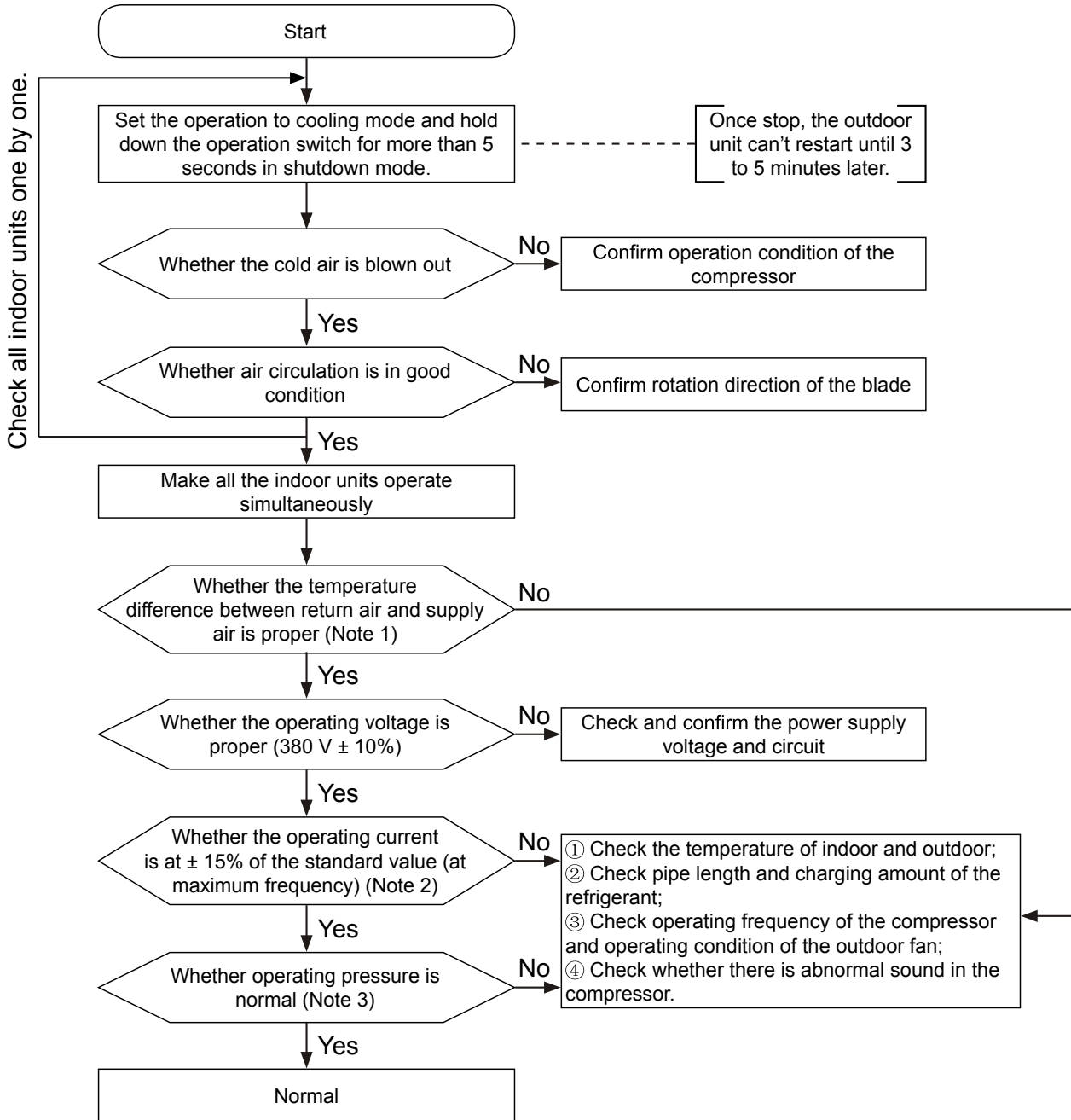

D. Heating operation confirmation

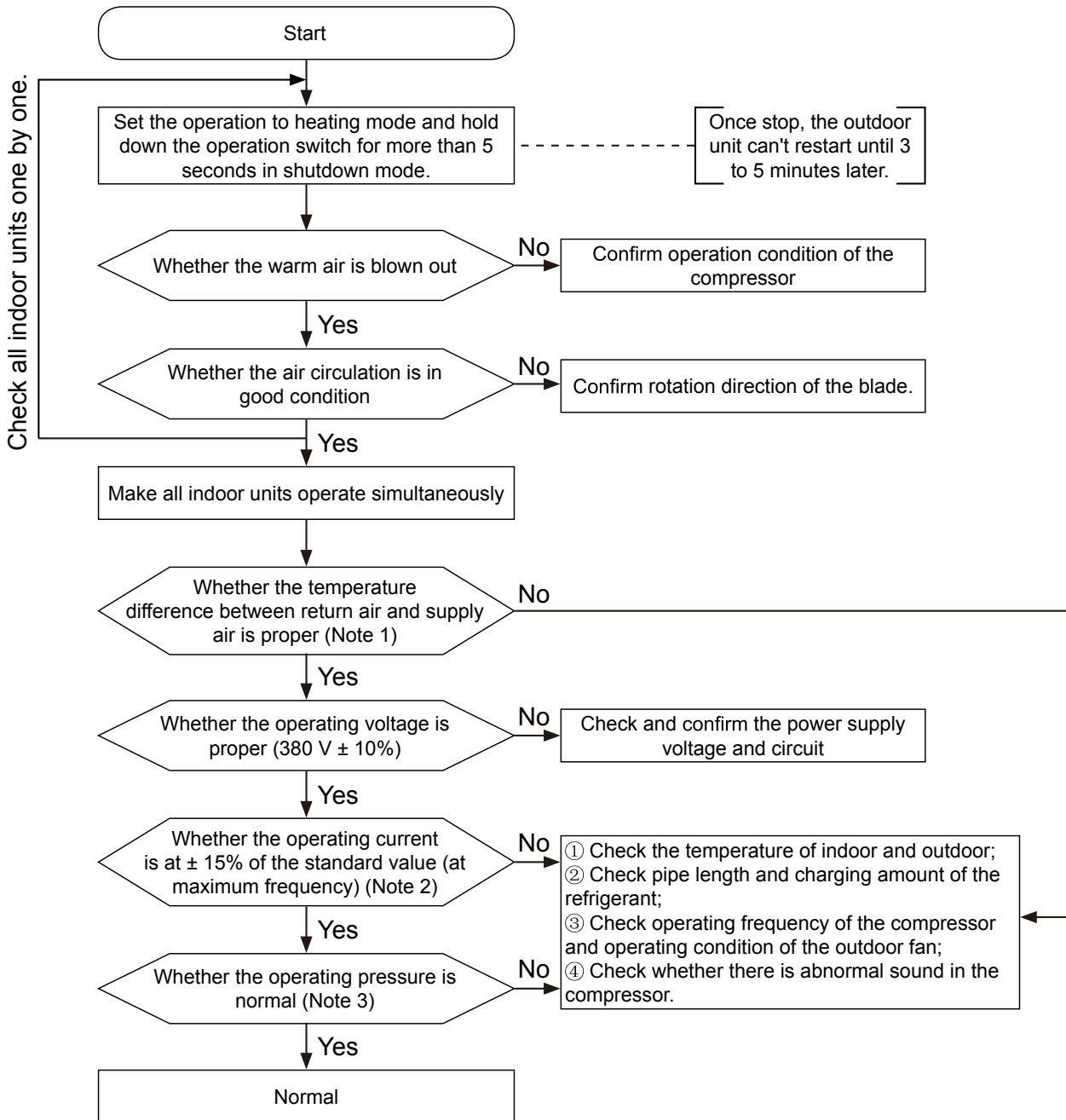

Note 1

The general standard for temperature difference between inlet and outlet air

In "cooling" operation, it is normal that the dry bulb temperature difference between inlet air and outlet air of the air conditioner is over 10°C (at the maximum frequency) after 30 minutes at least.

In "heating" operation, it is normal that the dry bulb temperature difference between inlet air and outlet air of the air conditioner is over 14°C (at the maximum frequency) after 30 minutes at least.

Note 2

General standard for operating current

It is normal that the current in either cooling/heating operation mode is within $\pm 15\%$ of the calibrated current.

The value of current may have the following differences due to different operation conditions: When higher than the standard value of the current: the temperature of indoor and outdoor is high; heat dissipation of outdoor unit is poor. When lower than the standard value of the current: the temperature of indoor and outdoor is low; refrigerant gas leaks (insufficient refrigerant).

Note 3

General standard for operating pressure

Cooling (at the maximum frequency)	High pressure 2.0~3.8 MPa	Indoor 18-32°C Outdoor 25-35°C
	Low pressure 0.6~1.0 MPa	
Heating (at the maximum frequency)	High pressure 2.2~3.0 MPa	Indoor 15-25°C Outdoor 5-10°C
	Low pressure 0.3~0.8 MPa	

Values after 15-minute operation (the temperature therein refers to dry bulb temperature with unit of °C)

The transformation trend of high pressure and low pressure due to change of operation condition

Refrigeration/heating: indoor temperature rises – high/low pressure rises

Indoor temperature drops – high/low pressure drops

Outdoor temperature rises – high/low pressure rises

Outdoor temperature drops – high/low pressure drops

Evaluating unit through test device

Operation	Begin to operate the system whose complete setting has been confirmed.	
	Operating methods: 1. Switch the BM1, BM2 to OFF, search the indoor units and outdoor unit to check if the number of indoor units are right. 2. Switch the SW9, SW10, SW11 to 0, 13, 2 respectively, then press SW2 for 2 seconds, the digital display tube will display "1111" and indoor unit will enter into cooling operation; or switch SW9, SW10, SW11 to 0, 14, 2 respectively, then press SW2 for 2 seconds, the digital display tube will display "1111", indoor unit will turn on automatically and enter into heating operation. Frequency of compressor is controlled by low pressure control for cooling, and high pressure control for heating.	

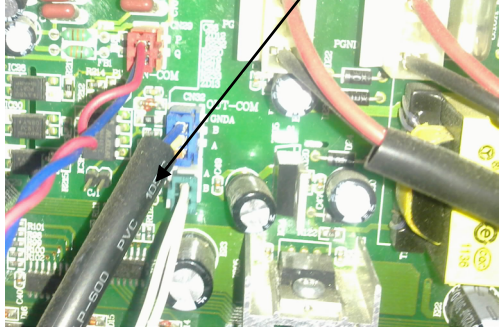
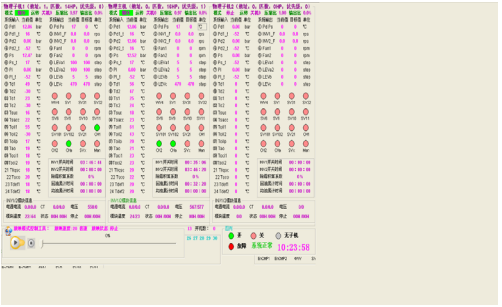
<p>Data measuring</p>	<p>1. Connecting methods of device: Insert one end of data line into the terminal of main PCB CN31 with a two-core terminal, one end connects with 485 device or Gangda device, the other end of the device connects computer.</p> <p>2. The data that can acquire through device Outdoor unit: The frequency of outdoor unit compressor/Outdoor fan speed/Opening of outdoor electronic expansion valve/High pressure of outdoor unit/Corresponding saturation temperature of outdoor unit's high pressure/Low pressure of outdoor unit/ Corresponding saturation temperature of outdoor unit's low pressure/Discharging temperature/Suction temperature/Oil temperature/Temperature of condenser outlet pipe/Ambient temperature/Temperature of defrosting sensor/Starting of all kinds of solenoid valve.</p> <p>Indoor unit: Temperatures of gas pipe and liquid pipe, opening angle of electronic expansion valve/Display of failure.</p> <p>3. Test device can display failures of the unit during operation, moreover it can realize a function of storing data in real time, and the test data can be stored in computer.</p> <p>4. Prepare a report according to the test data and submit it to user.</p>	<p>Position of inserting test device (CN31)</p>  <p>It is normal if there is high pressure frequency limitation or high discharging temperature frequency limitation when outdoor ambient temperature is high and all the indoor units are operating.</p>
<p>Confirmation of the data</p>	<p>The confirmation of running data/Timing and recording of the measurement.</p> <p>After the measurement is begun, check the system pressure through detection software. Generally, the cooling low pressure is about 7.5kg and the heating high pressure is about 28kg under rated cooling and heating modes. Then observe if operation under each parameter is normal.</p> <p>There is a picture about cooling operating parameters' data in the right column, after operating about half hour, the unit remains stable.</p> <p>Check if there is a blockage in capillary during operation, if any, replace it.</p> <p>Check if there is contact between refrigerant piping and capillary tube, if any, deal with it.</p> <p>Check if wires of sensor (such as wiring, pressure sensor, etc.) are too tight, or contact with vibrating pipe, if so, deal with it.</p> <p>Check if the value of sensor is correct.</p>	

13. Outdoor PCB Photo

Outdoor PCB (MHW505A021) photo

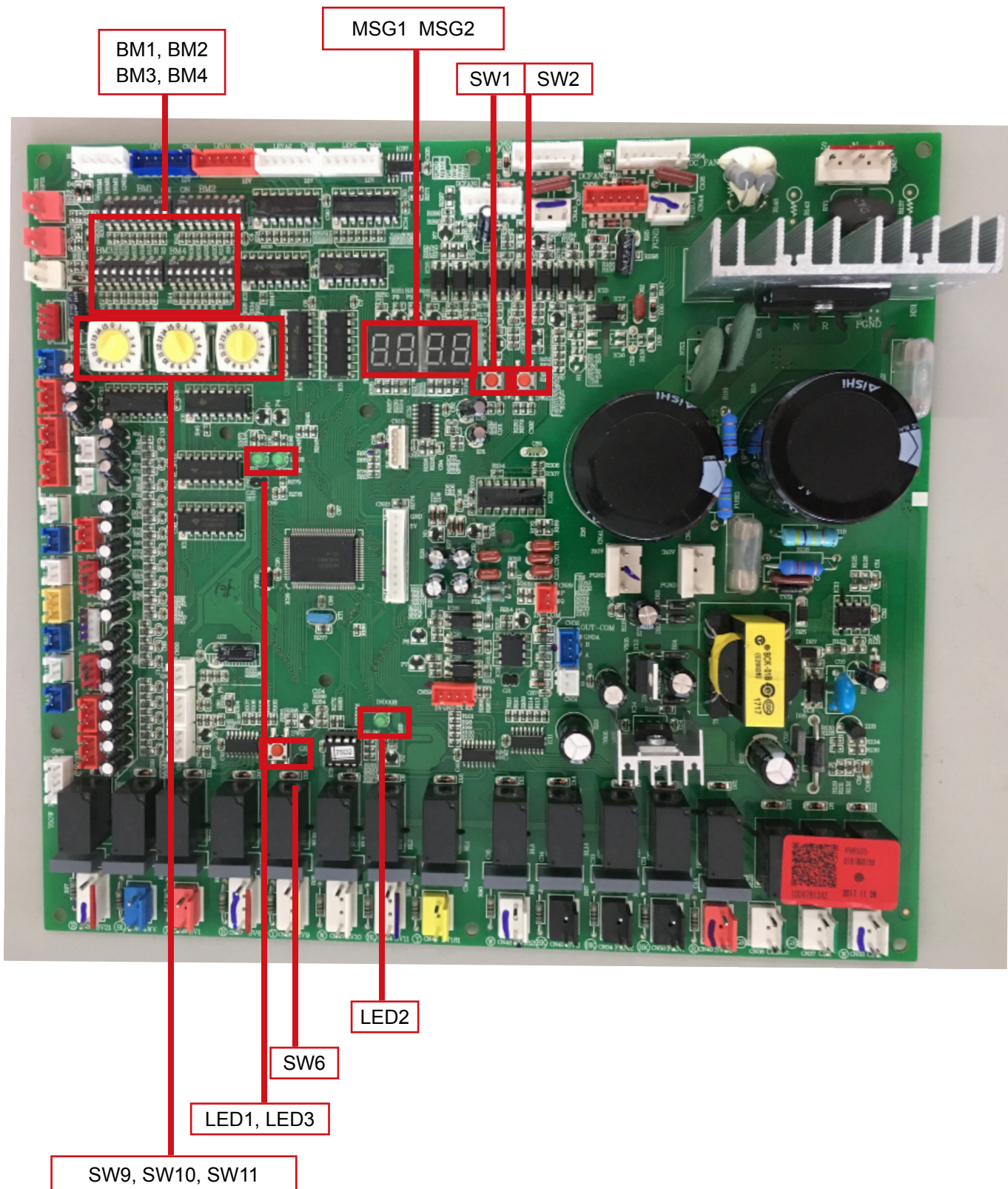

Power module (MHW555D002 and MHW555D001)

Note:

1. Power module MHW555D002 match with power module driver board MHW505A022 control the compressor ANB66F
2. Power module MHW555D001 match with power module driver board MHW505A020 control the compressor ANB52F and ANB42F

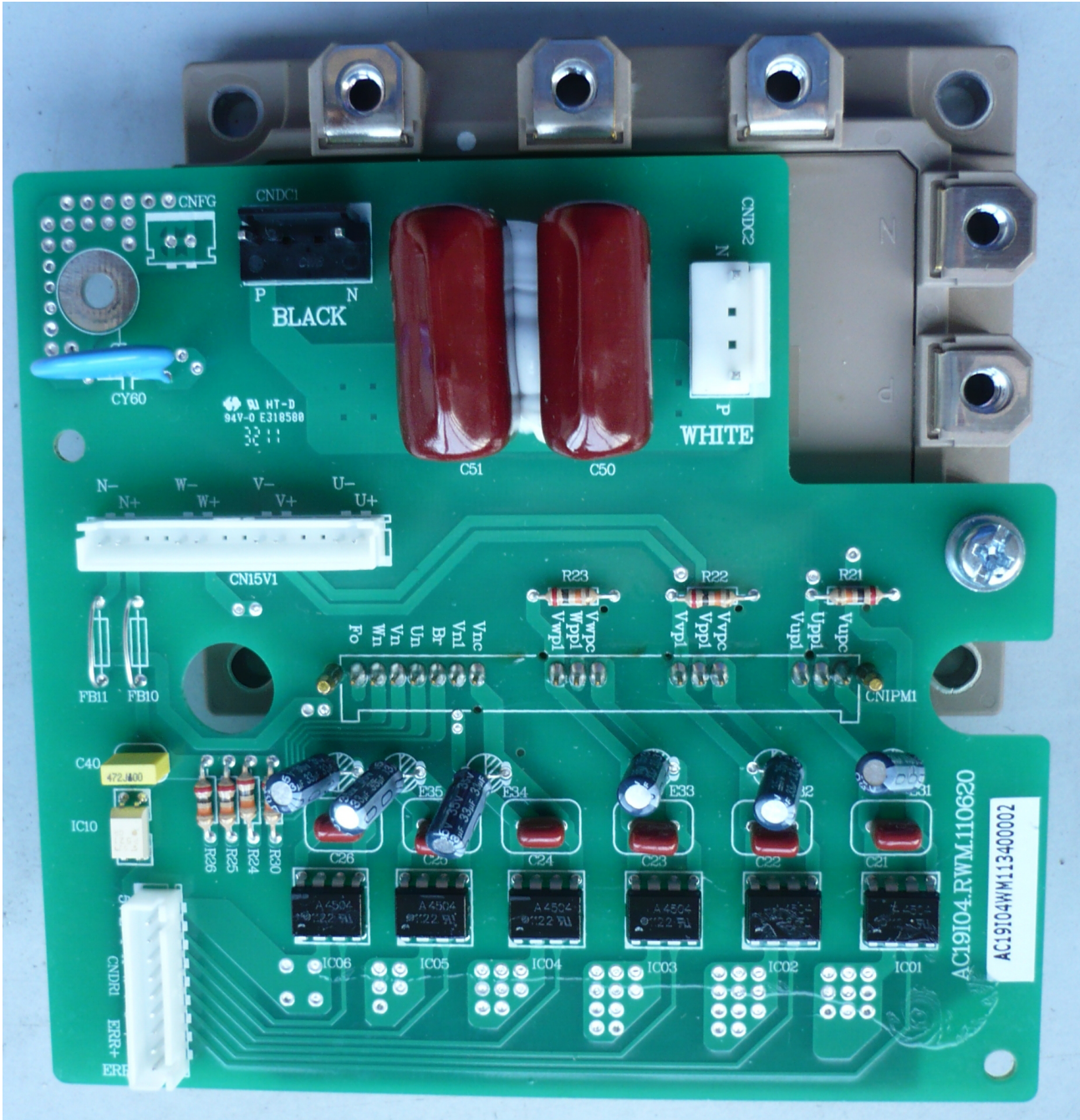

Power module driver board (MHW505A022 and MHW505A020)

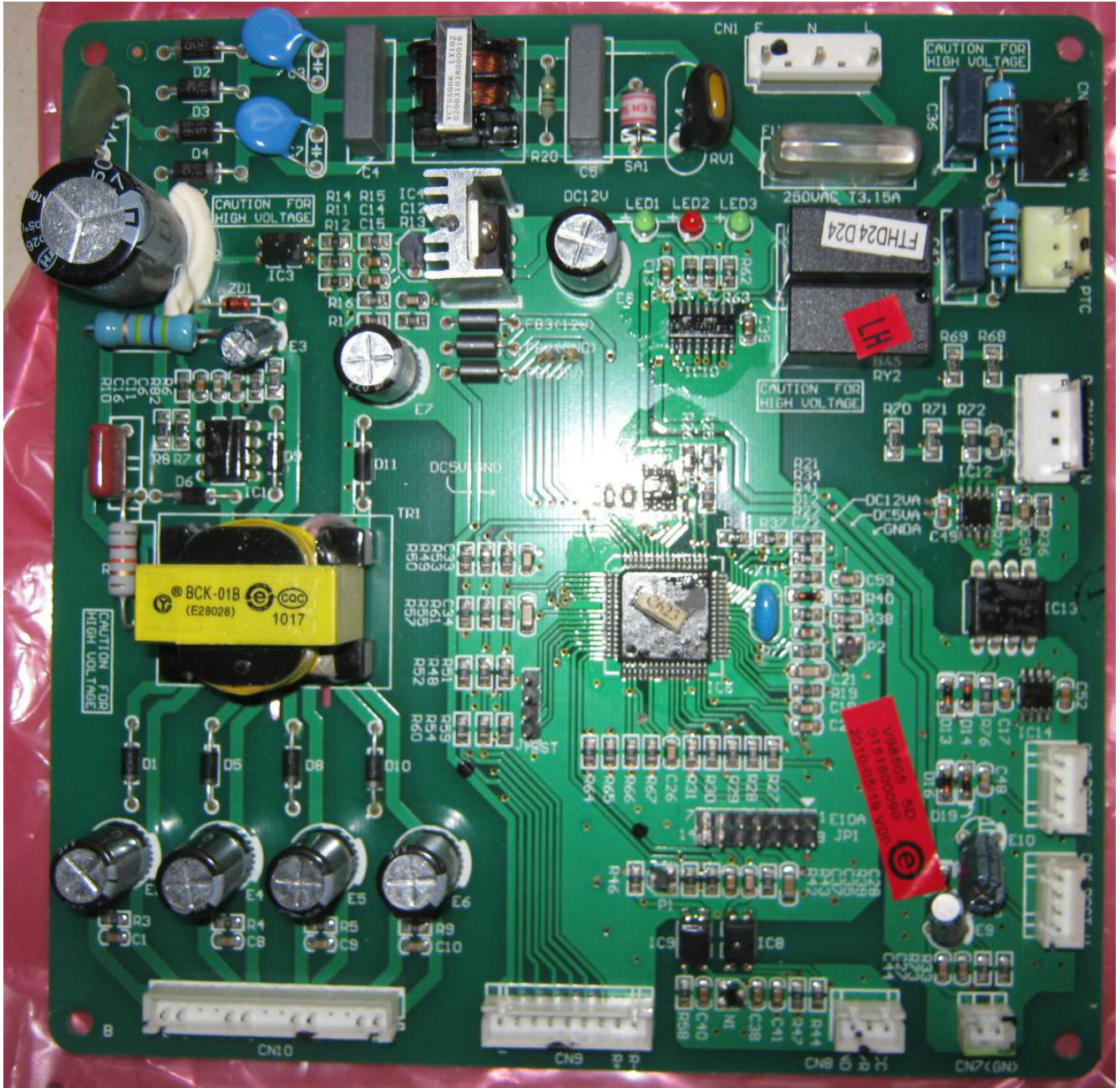

Filter board (MHW505A012)

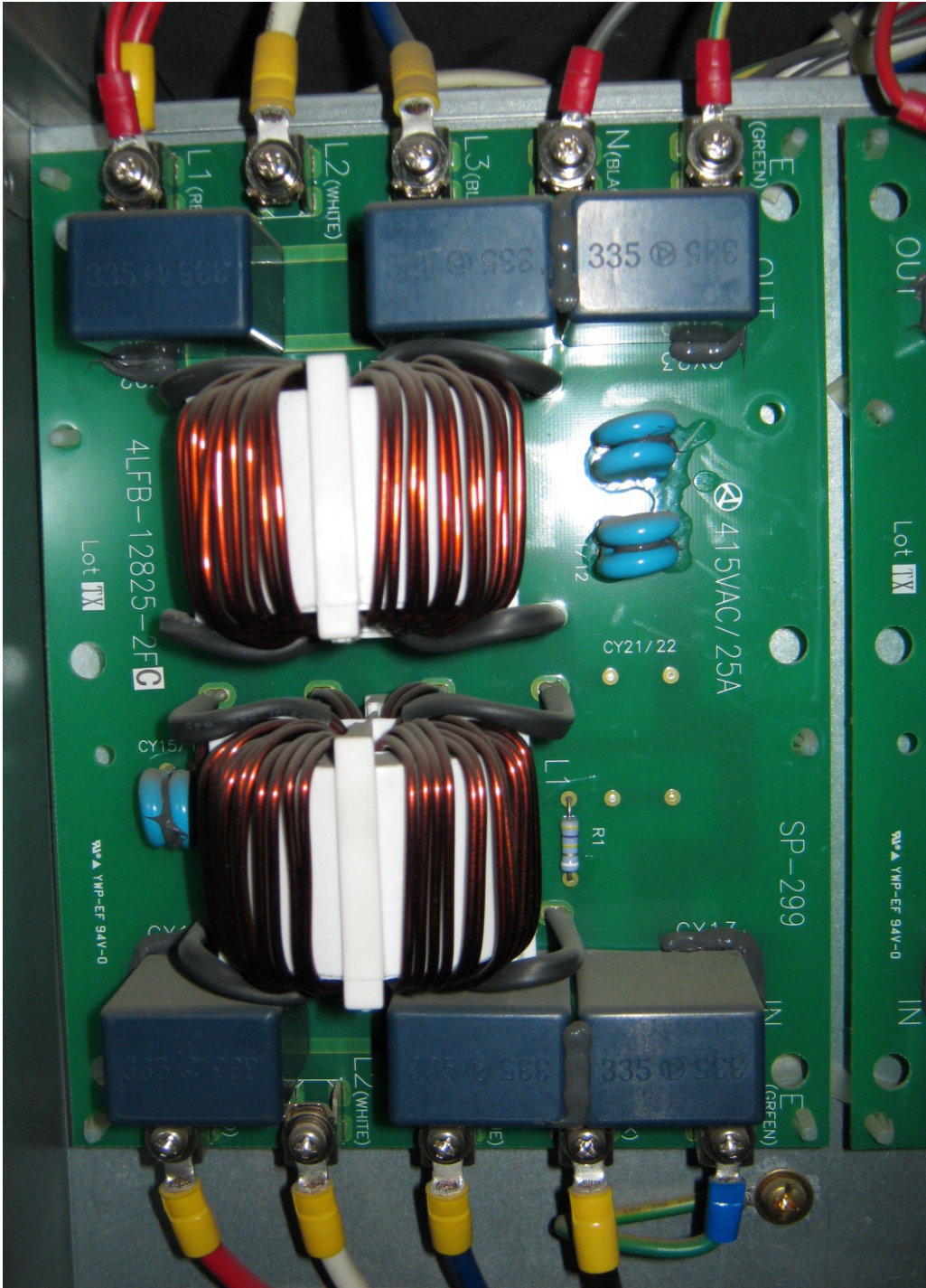

14. Outdoor PCB Dip Switch Setting

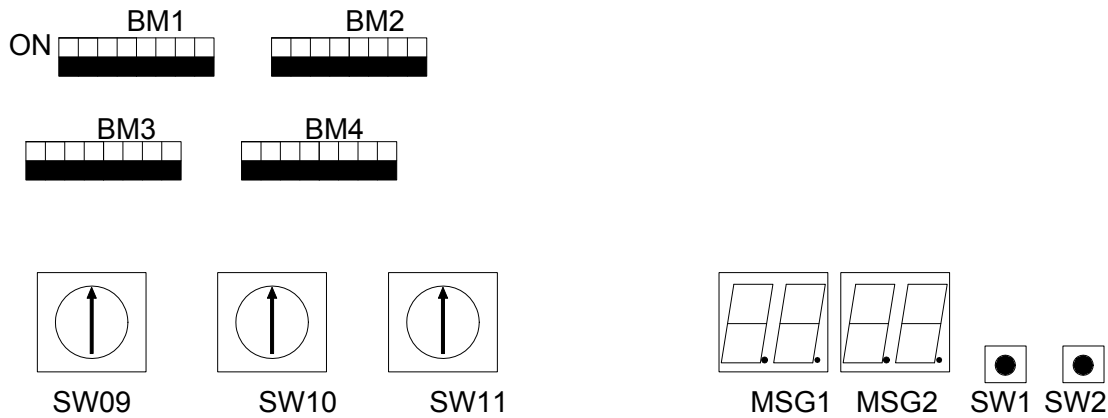

LED light definition:

- LED1: communication lamp among outdoor units.
The lamp flicker frequency is 0.5s/time under normal condition; once occurs the communication faulty, the lamp flicker frequency is 1s/time.
- LED2: communication lamp between indoor units and outdoor units.
The lamp flicker frequency is 0.5s/time under normal condition; once occurs the communication faulty, the lamp flicker frequency is 1s/time.
- LED3: communication lamp between outdoor PCB and inverter board.
The lamp flicker frequency is 0.5s/time under normal condition; once occurs the communication faulty, the lamp flicker frequency is 1s/time.

Concept identification:

- Physical master unit: the outdoor unit, whose number is set as 0 by dip switch(BM1-7 and BM1-8), is the communication sponsor and in charge of the communication with indoor unit, also works as initiator of communication of the whole outdoor unit.
- Function master unit: the outdoor unit, whose priority is set as 0, operates with the highest priority.
- Physical slave unit: the outdoor unit, whose number is not set as 0 by dip switch(BM1-7 and BM1-8).
- Function slave unit: the outdoor unit, whose priority is set as 1~3, not operates with the highest priority.
- Setting of group class: the setting of physical master unit is valid for the whole unit. For example: setting of quiet, anti-snow, piping of medium length and so on. Physical master unit conducts all sorts of setting.
- Setting of local class: it is only valid for this unit, not for the whole unit. For example: setting of backup operation of sensor, selecting variable frequency inverter board and so on.

Dip switch introduction:

- BM1 is usually set by the engineer on site; BM2, BM3, BM4 are pre-set in the factory.
- BM1_1: Master outdoor unit searches the total outdoor units after power on at first time. The quantity of total outdoor units is floating from right to left on digital tube SMG1 and SMG2. "1=0" is one outdoor unit, "2=01" is two outdoor units, "3=012" is three outdoor units.
- BM1_2: Master outdoor unit searches the total indoor units after locked the quantity of the outdoor units. The quantity of total indoor units is floating from right to left on digital tube SMG1 and SMG2. "-04-" is 4 indoor units, "-06-" is 6 indoor units, "-15-" is 15 indoor units.
- BM1_3: The setting is OFF or ON. Default is ON. Once power off, unit software shall reset to "OFF" automatically ignoring BM1_3 setting.

Note: In the following tables the grey background is default setting.

BM1	Definition	Introduction		
BM1_1	Outdoor searching after startup	OFF	Begin to search outdoor	
		<u>ON</u>	Stop searching outdoor and lock the quantity	
BM1_2	Indoor searching after startup	OFF	Begin to search indoor	
		<u>ON</u>	Stop searching indoor and lock the quantity	
BM1_3	Start up	Power on, no action	Default: unit shall startup after 6 hours preheat or oil temp. reaches the target value	
		Power on, change OFF to ON	Unit shall startup after 6 hours preheat or oil temp. reaches the target value (note: here the target value is lower than the target value when the BM1-3 on "OFF" position).	
BM1_4	Heating when outdoor temperature over 25°C	OFF	Ambient temp. >25 °C , available.	
		<u>ON</u>	Ambient temp. >25 °C , unavailable.	
BM1_5	Over match setting	OFF	Indoor total capacity >130%, system function normally	
		<u>ON</u>	Indoor total capacity>130%, system alarm	
BM1-6	Cooling only or heat pump selection	OFF	Heat pump	
		<u>ON</u>	Cooling only	
BM1_7	Address setting	BM1_7	BM1_8	Outdoor address
		OFF	OFF	0# (physical master unit)
		OFF	<u>ON</u>	1#
		<u>ON</u>	OFF	2#
BM2	Definition	Introduction		
BM2_1	Quiet running function	OFF	Quiet running function is unavailable (default)	
		<u>ON</u>	Quiet running function is available	
BM2_2	Anti-snow function	OFF	Anti-snow function is unavailable (default)	
		<u>ON</u>	Anti-snow function is available	
BM2_3	Start mode selection	BM2_3	BM2_4	Set content
		OFF	OFF	First open priority
		OFF	<u>ON</u>	After opening priority
		<u>ON</u>	OFF	Cooling priority, any one indoor unit runs in cooling mode, the outdoor unit will run in cooling mode, the indoor units running in heating mode will stop.
BM2_5	Defrosting condition Selection	<u>ON</u>	<u>ON</u>	Heating priority, any one indoor unit runs in heating mode, the outdoor unit will run in heating mode, the indoor units running in cooling mode will stop.
		BM2_5	BM2_6	Selection item
		OFF	OFF	Default setting (Normal installation condition)
		OFF	<u>ON</u>	Low humidification in winter condition
BM2_7 BM2_8	Piping length selection (Main pipe length: between outdoor to 1 st branch pipe)	<u>ON</u>	OFF	High humidification in winter condition (when outdoor unit defrosting is not clear, can set the dip switch on this position)
		BM2_7	BM2_8	Selection item
		OFF	OFF	Default setting (Medium piping length:30~60m)
		OFF	<u>ON</u>	Long piping length: 60~90m
		<u>ON</u>	OFF	Short piping length: 0~30m

BM3	Definition	Introduction				
BM3_1	The type of outdoor unit	OFF	Default (YDV T3 outdoor unit)			
BM3_2		<u>ON</u>				
BM3_3		<u>ON</u>				
BM3-4	Inverter board type	OFF	Default			
BM3_5 BM3_6 BM3_7 BM3_8	HP setting of outdoor units	BM3_5	BM3_6	BM3_7	BM3_8	HP
		OFF	OFF	OFF	<u>ON</u>	8HP
		OFF	OFF	<u>ON</u>	OFF	10HP
		OFF	OFF	<u>ON</u>	<u>ON</u>	12HP
		OFF	<u>ON</u>	OFF	OFF	14HP
		OFF	<u>ON</u>	OFF	<u>ON</u>	16HP
		OFF	<u>ON</u>	<u>ON</u>	OFF	18HP
		OFF	<u>ON</u>	<u>ON</u>	<u>ON</u>	20HP
		<u>ON</u>	OFF	OFF	OFF	22HP
		<u>ON</u>	OFF	OFF	<u>ON</u>	24HP

BM4	Definition	Introduction			
BM4_1	Indoor quantity lock selection	OFF	Available (with the quantity lock function)		Group class (physical master unit is valid)
		<u>ON</u>	Unavailable (without the quantity lock function)		
BM4-2	Drop selection of indoor units	OFF	Without height drop between indoor units		Group class (physical master unit is valid)
		<u>ON</u>	With height drop between indoor units		
BM4_3	Outdoor static pressure selection	OFF	The maximum speed of outdoor fan motor is 14 (default)		Local class
		<u>ON</u>	The maximum speed of outdoor fan motor is 15		
BM4_4	Reserved	OFF			
BM4_5	Reserved	OFF			
BM4_6	Communication protocol between indoor and outdoor unit selection	OFF	New protocol		Group class (physical master unit is valid)
		<u>ON</u>	Old protocol		
BM4-7 BM4-8	Indoor and outdoor unit height drop setting	BM4_7	BM4_8	Dip switch definition	
		OFF	OFF	Normal height drop	
		OFF	<u>ON</u>	The outdoor is higher, the height drop between indoor and outdoor unit is more than 50 meters, and less than 90 meters	
		<u>ON</u>	OFF	The outdoor is lower, the height drop between indoor and outdoor unit is more than 40 meters, and less than 70 meters	

Note: communication protocol between indoor and outdoor units

The new communication protocol is faster than the old communication and its control content is more than the old one.

The indoor PCB 0151800113, 0151800161, 0151800161B, 0151800161C, 0151800227, 0151800227A, 0151800244, 0151800244B, 0151800244BA, 0151800086A, 0010451751AF, 0151800141A, 0010451751AE and 0151800141 are new communication protocol.

The indoor PCB 0151800086 and 0010451181A are old communication protocol.

Old communication protocol indoor PCB can't connect with new communication protocol outdoor, so if this outdoor unit connect with old communication protocol indoor, need set the dip switch BM4-6 to ON position.

Monitor tools

According to the dip switch code comparison table of outside unit, adjust SW9, SW10 and SW11 and observe operation parameters of the unit, and then record the parameters in the form of operation and commissioning. The displayed contents are defined as follows:

- Buttons: SW2 (UP) and SW1 (DOWN)
- Dip switch panel: SW9, SW10 and SW11: they are settable dip switches from 0 to 15.
- Displayed part: LED1, LED2, LED3 and LED4: the four digital tubes arranged from left to right.

1) Parameter observation of indoor unit

SW9 and SW10 indicate number of indoor unit, and SW11 indicates parameter description of indoor unit.

SW9	SW10	Indoor unit address
0	0-15	1-16
1		17-32
2		33-48
3		49-64

SW11	Functions	Digital tube MSG1 and MSG2 display
3	Indoor unit program version	If communication is normal, show the indoor unit program version (one decimal). If communication stops, normally show "0000" (failing communication for 5 consecutive rounds). If communication has been abnormal, show "----". For example, "F0.1" means indoor unit version is V0.1
4	Indoor abnormal	Display indoor failure code; no failure, display 0
5	Indoor capacity	Indoor capacity (Unit: W, a decimal), 1.5 HP displays 1.5
6	Indoor EEV open angle	Electronic expansion valve (EEV) open angle (Unit: Pls)
7	Indoor ambient temp. "Tai"	Ambient temperature (Unit: °C)
8	Indoor gas pipe temp. "Tc1"	Gas pipe temperature (Unit: °C)
9	Indoor liquid pipe temp. "Tc2"	Liquid pipe temperature (Unit: °C)
10	Startup mode, actual operating wind speed and capacity code of indoor unit	LED1 shows startup mode such as O: Shutdown C: cooling H: Heating LED2 indicates actual operating wind speed of indoor unit (0 - stop, 1 - low wind, 2 - medium wind and 3 - high wind) LED3 and LED4 indicate capacity code (0~15). For example, C311 indicates cooling operating at high wind, and the capacity is 11.
11	Setting temperature "Tset" of indoor unit	Setting temperature (Unit: °C)
12	Wrong wiring inspection	0 shows no failure, 79 shows wiring connection failure (indoor no display)
13	Forced startup & shutdown of indoor unit for cooling	• Hold down SW2 (UP) for 2 seconds until 1111 is displayed, it means startup
14	Forced startup & shutdown of indoor unit for heating	• Hold down SW1 (DOWN) for 2 seconds until 0000 is displayed, it means shutdown

2) Outdoor unit parameters observation

It is parameter observation of outdoor unit when SW11 range is 0, 1, and 15; 0~3 of SW9 is used to select outdoor unit number, 0 represents the main unit and 1 represents No. 1 sub-unit; SW10 indicates parameter description of outdoor unit.

Note:

The main unit can display parameters of other outdoor units and indoor units, while the sub-unit only displays its own parameters

SW9	SW10	SW11	Functions	Digital tube MSG1 and MSG2 display
0-2 (Unit No.)	0	0	Display outdoor failure code	<p>Failure code transmitted by outdoor bus data. If no failure, display the time as second counting down from the 6 hours for pre-heating.</p> <ul style="list-style-type: none"> • Press SW2 (UP) for 2s continuously, display 1111, and access the condition of history fault inquiry to inquire the recent 10 faults: with fault sequence number and fault code displayed by flashing. Press SW2 (UP) once, sequence number will go up 1; press SW1 (DOWN) once, sequence number will decrease 1; 2 min later, quit the setting condition automatically. • Press SW1 (DOWN) for 2s continuously, display 0000, then quit query status and stop flashing. • When dip switch panel is at 13,0,0, press SW2 (UP) for 2s continuously, display 1111, thus history fault record can be cleared. • If capacity is more than 135% or less than 50%, startup is not allowed, and digital tube 000 will display "555.0" • If the temperature is above 26°C, heating is prohibited and startup is not allowed; then, digital tube 000 will display "555.1" • If cooling Ps is less than 0.23 Mpa or heating Ps is less than 0.12 Mpa, startup is not allowed, and then digital tube 000 will display "555.2" • If the temperature is above 54°C in cooling mode, startup is not allowed and then digital tube 000 will display "555.3"
	1	0	Display priority and capacity of outdoor unit	LED1 displays outdoor priority, LED2 displays "-", LED3 and 4 display capacity of outdoor unit (unit: HP)
	2	0	Display operation mode and operation output ratio of outdoor unit	LED1 shows O: Stop C: Cooling H: Heating LED2 to LD4 show: 60 shows 60% capacity output
	3	0	Rotating speed of outdoor fan 1	<ul style="list-style-type: none"> • Press SW2(UP) for 2s continuously, display 1111, then to set: flashing. Press SW2 (UP) once, wind speed will go up 1 level; press SW1 (DOWN) once, wind speed will decrease 1 level. 5 min later, quit the setting condition automatically.
	4	0	Rotating speed of outdoor fan 2	<ul style="list-style-type: none"> • Press SW1 (DOWN) for 2s continuously, display 0000, then quit the setting condition, and stop flashing. <p>Note: [345 indicates 345 rpm]</p>

SW9	SW10	SW11	Functions	Digital tube MSG1 and MSG2 display
0-2 (Unit No.)	5	0	Current frequency of inverter compressor INV1	<ul style="list-style-type: none"> • Press SW2(UP) for 2s continuously, display 1111, then to set: flashing and press SW2 (UP) once, the frequency will go up 1 Hz; press SW1 (DOWN) once, the frequency will decrease
	6	0	Current frequency of inverter compressor INV2	<ul style="list-style-type: none"> • Press SW1 (DOWN) for 2s continuously, display 0000, then quit the setting condition, and stop flashing. Note: [110.0 indicates 110.0 HZ] (When system failures, compressor is forbidden to start up.)
	7	0	LEVa1 valve opening of outdoor unit	<ul style="list-style-type: none"> • Press SW2 (UP) for 2s continuously, display 1111, then to set: flashing. Press SW2 (UP) to open the valve fully, and press SW1 (DOWN) to close the valve fully. 2 min later, quit the setting condition automatically.
	8	0	LEVa2 valve opening of outdoor unit	
	9	0	LEVb valve opening of outdoor unit	
	10	0	LEVc valve opening of outdoor unit	<ul style="list-style-type: none"> • Press SW1 (DOWN) for 2s continuously, display 0000, then to set, and stop flashing. Note: [0 -- 470 steps]
	11	0	Outdoor solenoid valve output indication	LED1: 4WV: 1 On 0 OFF -- high-order left-most LED2: SV1: 1 On 0 OFF LED3: SV31: 1 On 0 OFF LED4: SV32: 1 On 0 OFF
	12	0	Outdoor solenoid valve output indication	LED1: SV6: 1 On 0 OFF -- high-order left-most LED2: SV9: 1 On 0 OFF LED3: SV10: 1 On 0 OFF LED4: SV11: 1 On 0 OFF
	13	0	Outdoor solenoid valve output indication	LED1: SV181: 1 On 0 OFF LED2: SV182: 1 On 0 OFF LED3: SV21: 1 On 0 OFF LED4: insignificance, display "-"
	14	0	Heating band output	LED1: CH1: 1 On 0 OFF LED2: CH2: 1 On 0 OFF LED3: CHa: 1 On 0 OFF LED4: insignificance, display "-"
15	0	Program version	1.0 means Ver1.0	

SW9	SW10	SW11	Functions	Digital tube MSG1 and MSG2 display
0-2 (unit No.)	0	1	Pressure of Pd1	Unit: kg, 2 decimals
	1	1	Pressure of Pd2	
	2	1	Pressure of Ps	
	3	1	Discharge temperature of Td1	Unit: °C
	4	1	Discharge temperature of Td2	
	5	1	Defrosting temperature of Tdef1	
	6	1	Defrosting temperature of Tdef2	
	7	1	Temperature of Toi1	
	8	1	Temperature of Toi2	
	9	1	Temperature of Toci1	
	10	1	Temperature of Toci2	
	11	1	Temperature of Ts1	
	12	1	Temperature of Ts2	
	13	1	Temperature of Tsuc	
	14	1	Temperature of Tsacc	
15	1	Temperature of Toilp		

SW9	SW10	SW11	Functions	Digital tube MSG1 and MSG2 display
0-2 (unit No.)	0	15	Pressure of PI	Unit: kg, 2 decimals
	1	15	Ambient temperature of Tao	Unit: °C
	2	15	Pressure temperature of Pd1_temp	
	3	15	Pressure temperature of Pd2_temp	
	4	15	Pressure temperature of Ps_temp	
	5	15	Temperature of Tliqsc	
	6	15	Temperature of Tsc0	
	7	15	Pressure temperature of PI_temp	
	8	15	Switching time of inverter compressor INV1	Unit: minute
	9	15	Switching time of inverter compressor INV2	Unit: minute
	10	15	Current CT of inverter compressor INV1	Unit: A, a decimal
	11	15	Current CT of inverter compressor INV2	Unit: A, a decimal
	12	15	DC voltage of inverter compressor INV1	Unit: V
	13	15	DC voltage of inverter compressor INV2	Unit: V
	14	15	Module temperature of inverter compressor INV1	Unit: °C
15	15	Module temperature of inverter compressor INV2	Unit: °C	

It is used to view data in EE when SW9 is 12 and 13.

SW9	SW10	SW11	Functions	Digital tube MSG1 and MSG2 display
12	0	0	EE data of 000H address	Display the first 256-byte data in EE of local unit Address calculation: $\text{addr}=\text{SW10}\times 16+\text{SW11}$ Data display: hexadecimal display, H indicates hexadecimal number
	0	1	EE data of 001H address	
	
	0	15	EE data of 00FH address	
	1	0	EE data of 010H address	
	
	1	15	EE data of 01FH address	
	
13	15	15	EE data of FFH address	Display the last 256-byte data in EE of local unit Address calculation: $\text{addr}=\text{SW10}\times 16+\text{SW11}$ Data display: hexadecimal display, H indicates hexadecimal number
	0	0	EE data of 100H address	
	0	1	EE data of 101H address	
	
	1	15	EE data of 11FH address	
	
	15	15	EE data of 1FFH address	

Data parameter information and control modes of the whole system are displayed when SW9 is 0

SW9	SW10	SW11	Function	Operation methods
0	0	2	Refrigerant type	407A stands for 407 refrigerant 410A stands for 410A refrigerant-static display R22 stands for 22 refrigerant
0	1	2	Outdoor total capacity	48.0 stands for 48 HP
0	2	2	Outdoor QTY in one system	E.g.: 3 outdoors (including master outdoor)
0	3	2	Indoor QTY in one system	E.g.: 64
0	4	2	Running indoor QTY	Thermostat ON indicates indoor running
0	5	2	Indoor QTY whose operation modes are as the same as that of outdoor	E.g.: 13 indoors
0	6	2	Target temperature of cooling	Unit: °C
0	7	2	Target temperature of heating	
0	8	2	Refrigerant evacuation setting *only for outdoor evacuation. If indoor evacuation, do not set. Note: When it finishes, cancel the setting or re-electricity.	<ul style="list-style-type: none"> • Press SW2 (UP) for 2s continuously, display 1111 and start up; digital tube displays "YES". ■ Specific action: SV9, SV10 and SV11 open, LEVa1, 2, LEVb open for 100 pls, the other valves close compulsorily, and SV21 open and LEVc open for 470. • Press SW1 (DOWN) for 2s continuously, display 0000 and stops (setting is invalid when unit is running).

SW9	SW10	SW11	Function	Operation methods
0	9	2	Refrigerant charging setting *only for gas charged outdoor. If indoor is charged, do not set. Note: When it finishes, cancel the setting or re-electricity.	<ul style="list-style-type: none"> • Press SW2 (UP) for 2s continuously, display 1111 and start up; digital tube displays "YES". ■ Specific action: LEVa1 and 2 open for 470 Pls, the other valves close compulsorily, and SV21 open and LEVc open for 470. • Press SW1 (DOWN) for 2s continuously, display 0000 and stops (setting is invalid when unit is running.)
0	10	2	Wrong wiring inspection in cooling	<ul style="list-style-type: none"> • Press SW2(UP) for 2s continuously, display 1111 and start up; digital tube counts down judging time at second; after time arrives, display the result: ■ "00.00" shows the result is in conformity with the actual connection; ■ "01.05" shows one outdoor and 5 indoors are abnormal. To check the abnormal units by digital tube (indoor: X_X_12; outdoor: X_0_0); • Press SW1 (DOWN) for 2s continuously, display 0000, and stops.
0	11	2	Operation detection in case of heating false wiring	
0	12	2	Indoor expansion valve open fully	Press SW2 (UP) for 2s continuously, display 1111 and indoor valves open fully for 2 minutes, then indoor valves close automatically.
0	13	2	All indoor units running in cooling	<ul style="list-style-type: none"> • Press SW2(UP) for 2s continuously, display 1111, and start up; • Press SW1 (DOWN) for 2s continuously, display 0000, and stops.
0	14	2	All indoor units running in heating	
0	15	2	Cancel all manual controls (running type)	<ul style="list-style-type: none"> • Press SW2(UP) for 2s continuously, display 1111 and start up, then cancel the manual control; or press SW1(DOWN) for 2s continuously, display 0000 and then cancel the manual control; • Cancel items: Wrong wiring inspection in cooling/ heating mode; indoor running/stop totally; compulsory operation; rated operation, etc.

Dip switch setting condition of PCB board is displayed when SW9 is 15.

SW9	SW10	SW11	Functions	Operation methods
15	0	2	Setting condition of BM1 and BM2	Hexadecimal display, BM1: indicating by LED1 and LD2, BM2: indicating by LED3 and LED4.
15	1	2	Setting condition of BM3 and BM4	Hexadecimal display, BM3: indicating by LED1 and LED2, BM4: indicating by LED3 and LED4.
15	2	2	Capacity correction level	0 indicates that the pipe is short; 1 indicates the pipe length is moderate; 2 indicates that the pipe is long.
15	3	2	Defrosting compensation α	10, 8, 6.
15	4	2	Power damping (the maximum output is allowable)	100 indicates 100%, and 0 indicates output is forbidden.
15	5	2	Capacity overload detection	135 indicates there is limit, and 0 indicates there is no limit.
15	6	2	Heating limit when external air is more than 25 °C	25 indicates there is limit, and 0 indicates there is no limit.
15	7	2	Setting of mute operation	0 indicates non-mute operation, and 1 indicates mute operation.
15	8	2	Setting of anti-snow operation	0 indicates the operation without snow prevention, and 1 indicates the operation with snow prevention.
15	9	2	Operation setting of wind speed of sub-unit FAN of ThermoOff during operating of heating main unit	0 indicates there is no operation, and 1 indicates there is operation.
15	10	2	Insignificance	Insignificance.
15	11	2	High head setting	0 indicates invalidity, 1 indicates high head above outdoor unit and 2 indicates high head under outdoor unit.
15	12	2	Setting of 50 Hz and 60 Hz power supply detection	50 indicates 50 Hz, and 60 indicates 60 Hz.
15	13	2	Reservation	Reservation.
15	14	2	Type setting of outdoor unit	0 indicates AV*NMMEUA model, 1 indicates sideward air outlet model, and 2 indicates five-in-one model.
15	15	2	Reservation	Reservation.

Outdoor unit valve manual control

SW9	SW10	SW11	Functions	Operation methods
6	15	2	Cancel all the manual controls (component type)	<ul style="list-style-type: none"> • Press SW2 (UP) for 2s continuously, display 1111, then to quit, or press SW1 (DOWN) for 2s continuously, display 0000, then quit the set. • Cancel items: Movable component control by hand such as compressor, motor, electronic expansion valve (LEV), solenoid valve (SV) and so on (including evacuation and charging; excluding rated operation, compulsory operation, indoor run/stop, etc).

15. Outdoor system control function

15.1 Compressor control

1.1.1 Cycle start function of compressor

- (1) According to different load of indoor unit, determine the starting number of compressors and outdoor unit
- (2) If there is only 1 outdoor unit with 2 compressors, shift the priority of compressor 1 and 2 every 4 hours.
- (3) If there are several outdoor units, the priority of these outdoor units shall be shifted every 8 hours.
- (4) There are no fixed master or slaves in the YDV series system, and they are switched in turn according to the conditions.

1.1.2 Changes of the number of compressor

- (1) In one outdoor unit, when one compressor operating frequency reaches 75%, another one compressor is started. When the output ratio of two compressors drops to 25%, one of the compressors is stopped;
- (2) In the multiple outdoor units combination system, when the output ratio of one outdoor unit reaches 75%, another outdoor unit is started. When the total output ratio of all the outdoor units drops to 25%, one outdoor unit is stopped.

1.1.3 Compressor start delay

- (1) In the control of the compressor, in order to prevent the starting at differential pressure, it must take some time to balance the high and low pressure after stopping fully, the restarting will delay automatically, and the compressor can restart after stopping for 3 to 5 minutes.
2. When the operating mode shifts reversely from [cooling, dehumidifying] to [heating], the all compressors shall stop and delay 3~5 min to restart.
3. When power on, it shall delay 3~5 min to restart the compressor.
4. Before restart the compressor, when the oil temperature cannot meet the start requirement, it will delay the start until oil temperature can meet the requirement.

1.1.4 Compressor crankcase heater control

When the compressor is stopped, in order to prevent the refrigerant from dissolving in the compressor oil and diluting the compressor oil, the compressor oil temperature must be controlled at a certain value or more.

Even if the compressor is in operation, if the compressor oil temperature is too low, the heater is energized to heat it.

1.1.5 Compressor start protecting control:

- (1) Based on the superheat of the oil temperature of the compressor or the heating time of the heater after the power is turned on to determine whether to start the compressor. The purpose of this control is to prevent the oil of the compressor that has been stopped for a long time from being severely diluted by the refrigerant.
- (2) Compressor start protection control: In the first three minutes of start-up, the compressor's operating frequency is kept at 50 rps or 60 rps.

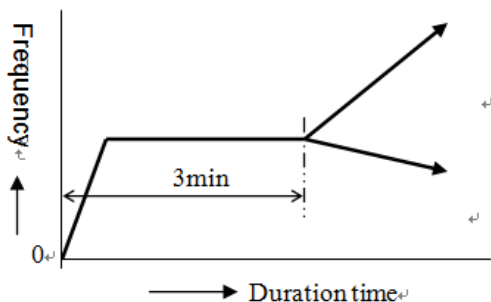

15.2 Fan control

Control of YDV series DC motor

The air supply speed of outdoor unit can be set from speed 0 to 15 in accordance with the operating mode.

The operating is commonly at speed 1 - 16, and it is CVT (Continuously Variable Transmission) control between speed 1 and 15.

15.3 4-way valve reversing

When the four-way valve is switched, the high pressure point of the valve needs to reach the minimum pressure difference required by the valve action.

15.4 Pressure control

1.4.1 High pressure control in cooling

(1) High pressure setting value: 2.2MPa.

(2) When the pressure of the high pressure is lower than 2.2MPa, the outdoor fan rotates at a high pressure of 2.2MPa for fuzzy control.

1.4.2 Low pressure control in heating

(1) Control the low-pressure pressure during heating, in order to improve the stability of the system and the reliability of the compressor.

(2) low pressure control in heating

• Low pressure control in heating is controlled by adjusting of the outdoor unit LEVa 1,2

15.5 Supercooling coil control

In cooling, the liquid outlet temperature Tliqsc of the supercooling coil is controlled by adjusting the electronic expansion valve LEVb.

Ordinary high drop, improve system operation efficiency by obtaining a certain degree of supercooling.

15.6 Defrosting control

When any outdoor unit meets the defrost entry condition, it will switch the four-way valve to start defrosting.

15.7 Oil return in heating

During oil return in heating, the four-way valve is switched to the cooling state and the indoor units are anti-cold air control in the whole process

15.8 Refrigerant recovery control for the OFF outdoor unit

In heating, the circulation refrigerant is insufficient, open the SV11 of the outdoor unit in the stopped state and the SV10 of the outdoor unit are opened, recycle the refrigerant into the circulatory system.

15.9 Compressor bottom temperature control

(1) When the temperature at the bottom of the compressor increases, the liquid bypass cooling is performed by opening the corresponding SV31,2.

(2) Before the compressor is started, the bottom of the compressor is heated by heater so that the internal liquid refrigerant evaporates sufficiently before the compressor is started to avoid excessive dilution of the compressor oil.

15.10 Compressor top temperature (Td1/Td2) control

(1) When the temperature at the top of the compressor rises, the liquid bypass cooling is performed by opening the corresponding SV31,2.

(2) When the temperature at the top of the compressor rises to 110°C, the output frequency of the compressor is limited.

15.11 High pressure protection control in heating

In heating, the high pressure is detected by the high pressure sensors Pd1, Pd2 of each compressor so as to control the compressor capacity to avoid high pressure rise.

15.12 Current safety control

(1) If the compressor current exceeds the specified upper limit, reducing the operating frequency for control before the current becomes the exit value.

(2) Even if the current dropped to the minimum speed cannot reach the upper limit value, the operation stops.

15.13 Module radiator temperature protection control

When the radiator temperature $T_{fin} \geq$ the limit temperature value, according to T_{fin} =limit temperature value to control the frequency limit of the INV compressor.

15.14 Compression ratio protection control

(1) When the compression ratio $\epsilon \geq$ limit value, the compressor speed limit control is performed according to the target of ϵ =limit value;

(2) When the compression ratio $\epsilon <$ limit value, the compressor speed limit control is performed according to the target of ϵ =limit value;

(3) When ϵ exceeds the limit value for a certain period of time, alarm the compression ratio error and shutdown.

15.15 Fresh air control

(1) When the system including a fresh air indoor unit, the air-conditioning operation is mainly conducted for the purpose of ventilation, and the cooling and heating air temperature targets are specified (only the fresh air operation).

The air temperature setting target for cooling and heating is 18~22°C.

(2) In cooling, when the outdoor ambient temperature is lower than the setting outlet air temperature, the fresh air only running in FAN mode; when the outdoor ambient temperature is higher than the setting temperature, the outdoor unit starts operating. When the outdoor temperature is greater than 43°C, the unit operates as much as possible, but also may be shut down due to protection.

(3) In heating, when the outdoor ambient temperature is higher than the setting outlet air temperature, the fresh air only running in FAN mode; when the outdoor ambient temperature is lower than the setting temperature, the outdoor unit will start running. When the outdoor temperature is lower than -5°C, the unit operates as much as possible, but also may be shut down due to protection.

15.16 Balancing oil operation

(1) When more than 2 outdoor units are in operation, the master / slave unit will balancing oil every 20 minutes;

(2) Balancing oil between the outdoor units, according to the pressure difference between the pressure of the high pressure chamber compressor oil pool of the oil discharging outdoor unit and the pressure of the suction side of the oil absorbing outdoor unit. during the balancing oil, the outdoor unit that discharges oil turns on the SV9, and the outdoor unit that absorbs oil opens the SV10.

15.17 Frequency converter cooling fan control

(1) The heat generate by the frequency converter forced cooling with a cooling fan;

(2) After the compressor is started, the fan runs immediately. After the compressor stops, the fan stops running.

15.18 Automatic back-up operation

(1) When a outdoor unit or compressor fails, other outdoor units and compressors that can be operated will enter to back-up operation;

(2) The classification of backup operation

① The system is stopped: all the masters and slaves unit stop.

② Single unit stop: The outdoor unit is stopped (the compressor of the abnormal unit stops).

③ Compressor stop: compressor unit stops (only abnormal compressor stops).

• It does not stop permanently when it stops abnormally, it will automatic recovery.

(3) The conditions for automatic backup operation: The BM1-6 on the PCB of master unit is set to OFF and is valid after re-powering.

15.19 Anti-snow outdoor fan control

(1) In winter, in order to prevent the fan part from being covered with snow, the fans of the outdoor unit are blown to disperse the snow at regular intervals during the stop.

(2) The master and slave unit independently control fan

(3) This function is set by outdoor dip switch BM2-2. After re-power, the setting is valid.

(4) Setting method:

When BM2-2 is OFF, the outdoor fan control is valid; when BM2-2 is ON, the control is invalid.

(5) Control content: When the outdoor ambient temperature is lower than 3°C, the outdoor unit in the OFF state will run at the highest speed for 1 minute every 10 minutes.

15.20 Stop and abnormal stop control

(1) Make sure the status of each functional component during shutdown is to prevent unit failure

(2) When the cooling is stopped, in order to prevent the high-pressure side liquid seal, when the outdoor is not completely stopped, the stopped outdoor unit SV11 performs the gas recovery control according to the conditions; when the outdoor unit is completely stopped, the last stopped outdoor unit, the SV10 continues to turn on for 2 minutes after the compressor stopped. The stopped indoor unit fan stops and the LEV is completely closed.

(3) When the heating is stopped, when the outdoor unit is not completely stopped, the stopped outdoor unit SV11 performs the gas recovery control according to the conditions; when the indoor unit's Thermo off is all stopped, all the outdoor units 4WV remain ON, the SV10 continues to turn on for 2 minutes after the compressor stopped, At this time, all indoor units LEV remain in the standby opening; when all indoor unit are shut down or faults stop, all the outdoor units 4WV will be switched to the OFF state. The indoor unit LEV is all off.

15.21 Refrigerant recovery control during maintenance

(1) When the outdoor unit is discarded and transferred, the refrigerant needs to be recovered from the outdoor unit. At this time, the outdoor unit performs the refrigerant recovery operation. (The refrigerant in the system is recycled to the outdoor unit)

(2) This control operation by hand

(3) Operation step:

① Turn on the unit for cooling operation

② Close the liquid pipe stop valve of each outdoor unit

③ After the low pressure of each outdoor unit is lower than 0.1 MPa for 10 seconds, closed the gas pipe stop valve of each outdoor unit at the same time.

④ The units are powered off and the refrigerant recovery is ended

15.22 Broken sensor detection and required temperature range

(1) The sensor's style range and breakage detection value

No.	Sensor	Unit	Application range	Disconnection range
1	Tfin	°C	-10~140	-11 °C below
2	Toil1, Toil2, Td1, Td2	°C	-20~140	-30 °C below
3	Ts, Ts1, Ts2, Tsc0	°C	-40~75	-50 °C below
4	Tao	°C	-40~75	-50 °C below
5	Tdef1, Tdef2, Toci1, Toci2, Tliqsc	°C	-40~75	-50 °C below
6	Toilp, Tsuc	°C	-20~140	-30 °C below
7	High pressure	MPa	0~4.15MPa	0V below or 3.49V above
8	Low pressure	MPa	0~1.7MPa	

(2) Disconnection detection method

① Detecting the AD value of temp. sensor less than 11 (open circuit) or more than 1012 (short-circuit) continuously for 60 seconds, the failure be confirmed and unit alarm.

② Toil1, Toil2, Td1, Td2, Toilp, and Tsuc sensor, do not judge the disconnection fault when the outdoor temperature is lower than 0°C.

③ The high-pressure and low-pressure sensors detect AD values less than 11 (open circuit) or more than 1012 (short-circuit) continuously for 30 seconds, alarm. During defrosting and after defrosting 3 minutes, do not alarm.

16. Failure Code

Master unit digital tube display	Indication on wired controller (hex)	Failure code definition	Failure description	Remarks
20-0	14	Defrosting temp. sensor Tdef1 failure	AD value is below 11 (open circuit) or over 1012 (short circuit) for 60 seconds, sensor has no alarm when abnormal in cooling mode.	Resumable
20-1	14	Defrosting temp. sensor Tdef2 failure		
21	15	Ambient temp. sensor Ta failure	AD value is below 11 (open circuit) or over 1012 (short circuit) for 60 seconds, sensor has no alarm when abnormal in cooling mode.	Resumable
22-0	16	Suction temp. sensor Ts1 failure		
22-1	16	Suction temp. sensor Ts2 failure		
22-2	16	Suction temp. sensor Tsacc failure		
22-3	16	Suction temp. sensor Tsuc failure	If AD value is over 1012 (short circuit) for 60 seconds, alarm. AD value is below 11 (open circuit) for 60 seconds, If $T_{ao} < 0^{\circ}\text{C}$, there is no open circuit alarm. If $T_{ao} \geq 0^{\circ}\text{C}$ and $ET < 0$, there is no alarm. $ET \geq 0^{\circ}\text{C}$, for 5 minutes, alarm. sensor has no alarm when abnormal in cooling mode.	
23-0	17	Discharging temp. sensor Td1 failure	AD value is below 11 (open circuit) or over 1012 (short circuit) for 60 seconds. If $T_{ao} \leq 0^{\circ}\text{C}$, no need to detect the open circuit failure (AD value is below 11.)	Resumable
23-1	17	Discharging temp. sensor Td2 failure		
24-0	18	Oil temp. sensor Toilp failure	If AD value is below 11 (open circuit) or over 1012 (short circuit) for 60 seconds, alarm. If $T_{ao} < 0^{\circ}\text{C}$, there is no open circuit alarm. If $T_{ao} \geq 0^{\circ}\text{C}$ and $ET \geq 0^{\circ}\text{C}$, no open circuit alarm within 5 minutes.	Resumable
24-1	18	Oil temp. sensor Toil1 failure		
24-2	18	Oil temp. sensor Toil2 failure		
25-0	19	Heat exchanger inlet temp. Toci1 failure	AD value is below 11 (open circuit) or over 1012 (short circuit) for 60 seconds, sensor has no alarm when abnormal in cooling mode.	Resumable
25-1	19	Heat exchanger inlet temp. Toci2 failure		
26-0	1A	Outdoor unit and indoor unit communication failure	Not finding connected indoor units for continuous 200 cycles	Resumable
26-1	1A		The searched indoor unit quantity is less than the set quantity for continuous 270 seconds	
26-2	1A		The searched indoor unit quantity is more than the set quantity for continuous 170 seconds	

Master unit digital tube display	Indication on wired controller (hex)	Failure code definition	Failure description	Remarks
27-0	1B	Oil temp. too high protection (ToiL1)	Toili $\geq 120^{\circ}\text{C}$ (E) at interval 25msec, continuous 2 times, and over the set value, then stop and alarm. The oil temp. 10°C lower than the alarm condition for 3 minutes after stop. If it occurs 4 times in an hour, confirm the failure. (the same as Td too high protection.)	Once confirmed, un-resumable
27-1	1B	Oil temp. too high protection (ToiL2)		
28-0	1C	High pressure sensor Pd1 failure	If AD value is below 11 (open circuit) or over 1012 (short circuit) for 60 seconds, alarm.	Resumable
28-1	1C	High pressure sensor Pd2 failure		
29	1D	Low pressure sensor Ps failure		
30-0	1E	High pressure switch HPS1 failure	When power on, the confirmation of OFF for continuous 2sec, alarm. If it occurs 4 times in an hour, confirm the failure.	Once confirmed, un-resumable
30-1	1E	High pressure switch HPS2 failure		
31	1F	Liquid pipe pressure sensor P1 failure	If AD value is below 11 (open circuit) or over 1012 (short circuit) for 60 seconds, alarm.	
32-0	20	Heat exchanger outlet temp. Tsc0 failure	If AD value is below 11 (open circuit) or over 1012 (short circuit) for 60 seconds, alarm, sensor has no alarm when abnormal in heating mode.	Resumable
32-1	20	Liquid pipe SC temp. of subcooler Tliqsc failure		
33-0	21	EEPROM (AT24C04) failure	EEPROM communication failure	Once confirmed, un-resumable
33-1			EEPROM data check failure(model code, check, etc.)	
33-2			EEPROM data logistic failure(data beyond limit, reverse sequence, etc.)	
34-0	22	Discharging temp. too high protection (Td1)	Td1 / Td2 $\geq 130^{\circ}\text{C}$ (E) at interval 25msec, continuous 2sec, and over the set value, then stop and alarm. The oil temp. 10°C lower than the alarm condition for 3 minutes after stop, then resume automatically. If it occurs 4 times in an hour, confirm the failure.	Once confirmed, un-resumable
34-1	22	Discharging temp. too high protection (Td2)		

Master unit digital tube display	Indication on wired controller (hex)	Indication on wired controller (hex)	Failure description	Remarks
35-0	23	4-way valve reversing failure	<p>After the 4-way valve is electrified for 3 minutes, if the below conditions can be met for continuous 10 seconds, that is conversing successfully:</p> <ul style="list-style-type: none"> · & · The outdoor compressor running normally · & · $T_{suc} - T_{def1} \geq 10^{\circ}\text{C}$ · $T_{suc} - T_{def2} \geq 10^{\circ}\text{C}$ · $P_d - P_s \geq \beta\text{Mpa}$ <p>※Otherwise, stop protection. ($T_{ao} > -10^{\circ}\text{C}$, $\beta=0.60$; $T_{ao} \leq -10^{\circ}\text{C}$, $\beta=0.40$) *4-way valve OFF starts up again after 3 minutes *If Thermo. OFF for 2 continuous times, Error stop.</p>	Once confirmed, un-resumable
35-1	23	4-way valve reversing failure	If there is 4-way valve of slave unit not electrified after master unit heating detection starts up for 20 min, alarm 35-1 failure.	
36-0	24	Oil temp. too low protection (Toil1)	<p>In normal operation (exclude start up, defrosting, oil return, remain, stop), if $T_{oil} < CT+10^{\circ}\text{C}$ for continuous 5 minutes, the unit stops for 170 seconds and then resumes automatically. If it occurs 3 times in an hour, lock the alarm.</p> <p>*The same as Td too low protection</p>	Once confirmed, un-resumable
36-1		Oil temp. too low protection (Toil2)		
37-1	25	Lack of phase of 3N power supply	S phase lack (L1 connect R, supply power for main PCB, L2 connect the S of the main PCB, L3 supply power for module, no fixed frequency compress, so don't detect phase sequence, only detect if it lack of phase	Once confirmed, un-resumable
38	26	High pressure sensor Pd too low protection	Pd too low fault shield	
39-0	27	Low pressure sensor Ps too low protection	After compressor is running (except for residual operation), if in cooling, $P_s < 0.10\text{MPa}$; in heating, $P_s < 0.05\text{MPa}$, in oil return, $P_s < 0.03\text{MPa}$ for continuous 5 minutes, stop and alarm. 170 seconds later, resume automatically. If it occurs 3 times in an hour, confirm the failure.	Once confirmed, un-resumable
39-1	27	Compressor ratio ϵ too high protection	After compressor is running, compression ratio $\epsilon > 8.0$ for continuous 5 minute, then stop and alarm. If in cooling, compression ratio $\epsilon > 9.0$ for continuous 1 minute or in heating, compression ratio $\epsilon > 8.5$ for continuous 1 minute or in heating, stop and alarm. 170 seconds later, resume automatically. If it occurs 4 times in an hour, confirm the failure.	
39-2	27	1# Compressor ratio ϵ too low protection	<p>In normal operation (exclude start up, defrosting, oil return, remain, stop), if compression ratio $\epsilon < 1.8$ for continuous 5 minutes, then stop and alarm. Or $\epsilon < 1.5$ for continuous 1 minute, then stop and alarm. 170 seconds later, resume automatically. If it occurs 4 times in an hour, confirm the failure.</p>	
39-3	27	2# Compressor ratio ϵ too low protection		

Master unit digital tube display	Indication on wired controller (hex)	Failure code definition	Failure description	Remarks
40-0	28	High pressure sensor Pd1 too high protection	After compressor is running, if Pd \geq 4.15MPa, stop and alarm.170 seconds later, resume automatically. If it occurs 4 times in an hour, confirm the failure.	Once confirmed, un-resumable
40-1	28	High pressure sensor Pd2 too high protection		
43-0	2B	Discharging temp. sensor Td1 too low protection	After 10 minutes for normal operation (exclude start up, defrosting, oil return, remain, stop), if Td < CT+10°C for continuous 5 minutes, stop and alarm. 170 seconds later, resume automatically. If it occurs 3 times in an hour, lock the alarm. After the compressor 1 or 2 alarm, the compressor 1 or 2 remain running. After 3 tiems locked ,the system stop and report fault	Once confirmed, un-resumable
43-1	2B	Discharging temp. sensor Td2 too low protection		
44	2C	Low pressure sensor Ps too high protection	Don't protect control, continue to work. If it occurs 4 times in an hour, locking.	Once confirmed, un-resumable
45	2D	Communication between outdoors failure	No communication within 30 seconds continuously (E)	Resumable
46-0	2E	Communication with INV1 board failure	No communication within 30 seconds continuously (E)	
46-1	2E	Communication with INV2 board failure	No communication within 30 seconds continuously (E)	
71-0	47	Fan 1 locked-rotor (Left)	Running at speed below 20rpm for 30s, or at speed of 70% lower than target for 2 minutes, stop. 170 seconds later, resume automatically. If it occurs 4 times in an hour, confirm the failure.	Once confirmed, un-resumable
71-1	47	Fan 2 locked-rotor (Right)		
72-0	48	Fan 1 reversal (Left)	Detect the reversal signal which send by the fan motor, and the reversal speed more than 700, alarm and stop.	Resumable
72-1	48	Fan 2 reversal (right)		
73-0	49	Fan 1 over current (Left)	When the motor speed lower than 400, occur over current signal for10 seconds, alarm and stop, if it occurs 5 times in an hour, lock the failure	Resumable
73-1	49	Fan 2 over current (right)		
74	4A	Emergency stop function switch failure	The emergency stop terminal of main PCB is open circuit	Once confirmed, un-resumable

Master unit digital tube display	Indication on wired controller (hex)	Failure code definition	Failure description	Remarks
75-0	4B	No pressure drop between high pressure and low pressure	n 1 minute after INV compressor starts up, Pd-Ps \leq 0.1MPa, then stop. 170 seconds later, resume automatically. If it occurs 4 times in an hour, confirm the failure.	Once confirmed, un-resumable
75-4	4B	Too small pressure drop between high pressure and low pressure	If Pd-Ps \leq 0.4MPa for 3 minutes, the outdoor unit protection stop. <ul style="list-style-type: none"> • 5 minutes after stopping protection, restart. • If there are more than 6 times of stopping protecting within 2 hours, Error stop. 	Once confirmed, un-resumable
76-0	4C	Incorrect outdoor unit quantity, address or capacity setting	Slave unit quantity setting is not in conformance with data in EEPROM of the master unit.	Reset
76-1			Slave unit quantity setting is not in conformance with data in EEPROM of the master unit.	
76-2			Slave unit capacity setting is not in conformance with data in EEPROM of the master unit.	
77	4D	Oil equalization protection among outdoor units	If ToilpB-ToilpA \leq 10 $^{\circ}$ C , alarm and stop. Not detecting in the course of startup, defrosting and oil return and in 10 minutes after oil return finishes.170 seconds later, resume automatically. If it occurs 2 times in an hour, lock the failure.	Once confirmed, un-resumable
78-0	4E	Lack of refrigerant alarm in cooling	When cooling compressor runs, Ps $<$ 0.1MPa for 30 minutes.	—
78-1	4E	Lack of refrigerant alarm in heating	When heating compressor runs, Ts1-ET $>$ 20 & Ts1-ET $>$ 20 & LEV open fully for 60 minutes, output the lack of gas alarm signal and not stop.	
80	50	Capacity not match to the outdoor units	In VRF system, the difference of capacity between any two outdoor units is more than 4HP, confirm the failure.	Un-resumable
83	53	The outdoor unit type setting wrong	The unit type of the master and the slave in the combined model are inconsistent (check the BM3-1, BM3-2, BM3-3 dip switch setting)	Un-resumable

Master unit digital tube display	Indication on wired controller (hex)	Failure code definition	Failure description	Remarks
99-X	63	The program self-checking fault	X=0~5	Resumable
110-0	6E	Module 1 over current	Module hardware over current	If it occurs 4 times in an hour, confirm the failure. Once confirmed, un-resumable
110-1	6E	Module 2 over current		
111-0	6F	Compressor 1 out of control	In the course of compressor startup or running, the unit can not detect the rotor position for 6 times, stop for 5s and then the INV control board resumes automatically.	
111-1	6F	Compressor 2 out of control		
112-0	70	Module 1 radiator temp. too high	If temp. > 94℃ , alarm. If temp.≤94℃ , INV control board resumes automatically.	
112-1		Module 2 radiator temp. too high		
113-0	71	Module 1 over load	Module over load	
113-1		Module 2 over load		
114-0	72	Module 1 DC under voltage	If DCBUS voltage < DC420V, alarm If DCBUS voltage > DC420V, INV control board resumes automatically.	
114-1		Module 2 DC under voltage		
115-0	73	Module 1 DC over voltage	If DCBUS voltage > DC642V、alarm If DCBUS voltage < DC642V, INV control board resumes automatically.	
115-1		Module 2 DC over voltage		
116-0	74	Communication with modular 1 abnormal	If communication signal can not be detected for continuous 30 seconds, alarm. After it can be detected, INV control board resumes automatically.	
116-1		Communication with modular 2 abnormal		
117-0	75	Module 1 software over current	Module software over current	
117-1		Module 2 software over current		
118-0	76	Module 1 startup failure	Compressor starts up fail for continuous 5 times.	
118-1		Module 2 startup failure		
119-0	77	Current detecting circuit abnormal of INV controller 1	Sensor for detecting current of inverter controller is abnormal. Cannot be connected or wrong connection.	
119-1		Current detecting circuit abnormal of INV controller 2		
120-0	78	Inverter controller 1 power supply abnormal	Power supply of inverter controller stops suddenly.	
120-1		Inverter controller 2 power supply abnormal		

Master unit digital tube display	Indication on wired controller (hex)	Failure code definition	Failure description	Remarks
121-0	79	Power supply of inverter controller 1 board is abnormal	Power supply of inverter controller board is broken down instantly.	If it occurs 4 times in an hour, confirm the failure. Once confirmed, un-resumable.
121-1		Power supply of inverter controller 2 board is abnormal		
122-0	7A	Radiator temp. sensor of inverter controller 1 is abnormal.	Resistor of temp. sensor abnormal or temp. sensor disconnected.	Once confirmed, un-resumable.
122-1		Radiator temp. sensor of inverter controller 2 is abnormal.		
125-0	7D	Compressor 1 frequency un-match	(Current frequency \geq INV target frequency+3Hz) or (target frequency >0 & actual frequency=0) for continuous 5 minutes	Resumable
125-1		Compressor 2 frequency un-match		
127	7F	MCU reset failure	If the master unit inspects that MCU of slave unit is reset, and the slave unit is running, the master unit alarm MCU reset failure, then the whole system stop. In heating mode, when restart up, 4WV will not be electrified, and the whole system will execute 4WV reversing operation again. If it occurs 4 times in one hour, confirm the failure.	Once confirmed, un-resumable
128	80	MCU program need update	The VRF system program is incompatible, program update prompt.	Un-resumable

When there is no failure, if the starting condition can not be met, digital tube on master unit will display stand-by code:

555.0	Standby state of capacity overmatch	When indoor horse power / outdoor horse power is over 130% or lower than 50%, the system is standby.	Resumable
555.1	Standby state of 26°C heating mode	When it is in heating mode with ambient temperature over 26°C, the system is standby.	
555.2	Standby state of super low pressure (lack of refrigerant)	When the unit starts in cooling with $P_s < 0.23\text{Mpa}$ or heating with $P_s < 0.12\text{Mpa}$, the system is standby.	
555.3	54°C cooling standby	High ambient models, the unit can't open if ambient temp. above 54°C, 7-segment board display: "555.3"	
555.6	Coded lock restrictions standby	Reach the system maximum operation time set by coded lock, the system standby	

※Failure code distribution introduction

0 ~ 19: indoor unit failure

20 ~ 99: outdoor unit failure

110 ~ 125: inverter module failure

126 ~ 128: soft self-detect

17. Troubleshooting

Failure code Outdoor digital display tube: 20-0,1 Indoor wired controller: 14	Indoor unit LED status	LED5		Failure description: Defrosting temperature sensors: Tdef1 and Tdef2 failure
	Outdoor unit LED status Normal	20 times		
		LED1	LED2	
		Normal	Normal	
1. Model	Failure diagnosis and troubleshooting			
Flow Logic III series	Diagnosis	Troubleshooting		
2. Abnormity detection method	<pre> graph TD A{Check if the corresponding connector of sensor is normal} -- N --> B[Replace it correctly by after-sales personnel on site.] A -- Y --> C{Check if resistance characteristic of the sensor is normal} C -- N --> D[Replace it correctly by after-sales personnel on site.] C -- Y --> E{Check if the temperature loop acquired by the computer board is normal} E -- Y --> F[Replace it correctly by after-sales personnel on site.] </pre>			
3. Abnormity confirmation conditions				
It is detected that the AD value is below 11 (open circuit) or above 1012 (short circuit) for 60 seconds continuously, the in abnormity will not be handled when the sensor operates in the cooling mode, and no alarm is given during defrosting and within 3 minutes at the end of defrosting.				
4. Possible causes				
<ul style="list-style-type: none"> ◆ The connection of sensor is not secure; ◆ The sensor is broken; ◆ The sensor is with resistance drift; ◆ The temperature acquired by PCB is not accurate. 				

Failure code Outdoor digital display tube: 21 Indoor wired controller: 15	Indoor unit LED status	LED5		Failure description: Ambient temperature sensor: Tao failure
		20 times		
	Outdoor unit LED status	LED1	LED2	
		Normal	Normal	
1. Model	Failure diagnosis and troubleshooting			
Flow Logic III series	Diagnosis		Troubleshooting	
2. Abnormity detection method	<pre> graph TD A{Check if the corresponding connector of sensor is normal} -- N --> B[Replace it correctly by after-sales personnel on site.] A -- Y --> C{Check if resistance characteristic of the sensor is normal} C -- N --> D[Replace it correctly by after-sales personnel on site.] C -- Y --> E{Check if the temperature loop acquired by the computer board is normal} E -- Y --> F[Replace it correctly by after-sales personnel on site.] </pre>			
3. Abnormity confirmation conditions				
It is detected that the AD value is below 11 (open circuit) or above 1012 (short circuit) for 60 seconds continuously, and no alarm is given during defrosting and within 3 minutes at the end of defrosting.				
4. Possible causes				
<ul style="list-style-type: none"> ◆ The connection of sensor is not secure; ◆ The sensor is broken; ◆ The sensor is with resistance drift; ◆ The temperature acquired by PCB is not accurate. 				

Failure code Outdoor digital display tube: 22-0, 1, 2, 3 Indoor wired controller: 16	Indoor unit LED status		LED5		Failure description: Suction temperature sensor: Ts1, Ts2, Tsacc and Tsuc failure
			20 times		
	Outdoor unit LED status		LED1	LED2	
		Normal	Normal		
1. Model	Failure diagnosis and troubleshooting				
Flow Logic III series	Diagnosis			Troubleshooting	
2. Abnormity detection method	<pre> graph TD A{Check if the corresponding connector of sensor is normal} -- N --> B[Replace it correctly by after-sales personnel on site.] A -- Y --> C{Check if resistance characteristic of the sensor is normal} C -- N --> D[Replace it correctly by after-sales personnel on site.] C -- Y --> E{Check if the temperature loop acquired by the computer board is normal} E -- Y --> F[Replace it correctly by after-sales personnel on site.] </pre>				
3. Abnormity confirmation conditions					
4. Possible causes					
<ul style="list-style-type: none"> ◆ Check if the sensor connection is normal; ◆ Check if resistance characteristic of the sensor is normal; ◆ Check if the temperature loop acquired by the PCB is normal. 					
<p>It is detected that the AD value is below 11 (open circuit) or above 1012 (short circuit) for 60 seconds continuously, and no alarm is given during defrosting and within 3 minutes at the end of defrosting.</p>					
<ul style="list-style-type: none"> ◆ The connection of sensor is not secure; ◆ The sensor is broken; ◆ The sensor is with resistance drift; ◆ The temperature acquired by PCB is not accurate. 					

FFailure code Outdoor digital display tube: 23-0,1 Indoor wired controller: 17	Indoor unit LED status	LED5		Failure description: Discharging temperature sensor: Td1and Td2 failure
		20 times		
	Outdoor unit LED status	LED1	LED2	
		Normal	Normal	
1. Model	Failure diagnosis and troubleshooting			
Flow Logic III series	Diagnosis		Troubleshooting	
2. Abnormity detection method	<pre> graph TD A{Check if the corresponding connector of sensor is normal} -- N --> B[Replace it correctly by after-sales personnel on site.] A -- Y --> C{Check if resistance characteristic of the sensor is normal} C -- N --> D[Replace it correctly by after-sales personnel on site.] C -- Y --> E{Check if the temperature loop acquired by the computer board is normal} E -- Y --> F[Replace it correctly by after-sales personnel on site.] </pre>			
3. Abnormity confirmation conditions				
It is detected that the AD value is below 11 (open circuit) or above 1012 (short circuit) for 60 seconds continuously. If $T_a \leq -10^\circ\text{C}$ the open circuit is detected after 3 minutes of compressor operation (AD value is below 11).				
4. Possible causes				
<ul style="list-style-type: none"> ◆ The connection of sensor is not secure; ◆ The sensor is broken; ◆ The sensor is with resistance drift; ◆ The temperature acquired by PCB is not accurate. 				

Failure code Outdoor digital display tube: 24-0, 1, 2 Indoor wired controller: 18	Indoor unit LED status	LED5		Failure description: Oil temperature sensor: Toilp, Toi1 and Toi2 failure
	Outdoor unit LED status	20 times		
		LED1	LED2	
		Normal	Normal	
1. Model	Failure diagnosis and troubleshooting			
Flow Logic III series	Diagnosis	Troubleshooting		
2. Abnormity detection method	<pre> graph TD D1{Check if the corresponding connector of sensor is normal} D2{Check if resistance characteristic of the sensor is normal} D3{Check if the temperature loop acquired by the computer board is normal} D1 -- Y --> D2 D1 -- N --> T1[Replace it correctly by after-sales personnel on site.] D2 -- Y --> D3 D2 -- N --> T2[Replace it correctly by after-sales personnel on site.] D3 -- Y --> T3[Replace it correctly by after-sales personnel on site.] style T1 fill:none,stroke:none style T2 fill:none,stroke:none style T3 fill:none,stroke:none </pre>			
3. Abnormity confirmation conditions				
4. Possible causes				
<ul style="list-style-type: none"> ◆ Check if the sensor connection is normal; ◆ Check if resistance characteristic of the sensor is normal; ◆ Check if the temperature loop acquired by the PCB is normal. 				
<p>It is detected that the AD value is below 11 (open circuit) or above 1012 (short circuit) for 60 seconds continuously, when $T_a \leq -10^\circ\text{C}$, no alarm is given; when $ET \leq -10^\circ\text{C}$, no alarm is given within 5 minutes.</p>				
<ul style="list-style-type: none"> ◆ The connection of sensor is not secure; ◆ The sensor is broken; ◆ The oil temperature sensor is with resistance drift; ◆ The temperature acquired by PCB is not accurate. 				

Failure code Outdoor digital display tube: 25-0, 1 Indoor wired controller: 19	Indoor unit LED status	LED5		Failure description: Heat exchanger inlet temperature: Toci1 and Toci2 failure
		20 times		
	Outdoor unit LED status	LED1	LED2	
		Normal	Normal	
1. Model	Failure diagnosis and troubleshooting			
Flow Logic III series	Diagnosis	Troubleshooting		
2. Abnormity detection method	<pre> graph TD A{Check if the corresponding connector of sensor is normal} -- N --> B[Replace it correctly by after-sales personnel on site.] A -- Y --> C{Check if resistance characteristic of the sensor is normal} C -- N --> D[Replace it correctly by after-sales personnel on site.] C -- Y --> E{Check if the temperature loop acquired by the computer board is normal} E -- Y --> F[Replace it correctly by after-sales personnel on site.] </pre>			
3. Abnormity confirmation conditions				
It is detected that the AD value is below 11 (open circuit) or above 1012 (short circuit) for 60 seconds continuously, the cooling mode operates the sensor abnormity without troubleshooting it, and no alarm is given during defrosting and within 3 minutes at the end of defrosting.				
4. Possible causes				
<ul style="list-style-type: none"> ◆ The connection of sensor is not secure; ◆ The sensor is broken; ◆ The sensor is with resistance drift; ◆ The temperature acquired by PCB is not accurate. 				

Failure code Outdoor digital display tube: 26-0, 1, 2 Indoor wired controller: 1A	Indoor unit LED status		LED5		Failure description: Communication between indoor unit and outdoor unit failure
			20 times		
	Outdoor unit LED status		LED1	LED2	
		Normal	Normal		
1. Model	Failure diagnosis and troubleshooting				
Flow Logic III series	Diagnosis		Troubleshooting		
2. Abnormity detection method	<pre> graph TD D1{Check if the communication wire of outdoor unit is shorted} -- Y --> T1[Replace it correctly by after-sales personnel on site.] D1 -- N --> D2{Check if the communication wire of outdoor unit is disconnected} D2 -- Y --> T2[Replace it correctly by after-sales personnel on site.] D2 -- N --> D3{Check if the communication wire P and Q of indoor and outdoor unit is incorrect} D3 -- Y --> T3[Replace it correctly by after-sales personnel on site.] D3 -- N --> D4{Check if there is same indoor unit No.} D4 -- Y --> T4[Adjust it correctly by after-sales personnel on site.] D4 -- N --> D5{Check if the computer board communication port of indoor and outdoor unit is correct} D5 -- N --> T5[Adjust it correctly by after-sales personnel on site.] D5 -- Y --> D6{Check if there is interference source} D6 -- Y --> T6[Eliminate the interference source.] D6 -- N --> D7{Replace indoor or outdoor computer board} </pre>				
3. Abnormity confirmation conditions					
4. Possible causes					
<ul style="list-style-type: none"> ◆ Grounded short-circuit of communication wire, or disconnected communication wire P and Q; ◆ Incorrect wiring of communication wire P and Q; ◆ Uniform indoor unit power supply, and partial indoor unit being powered off. ◆ Larger interference and unstable communication signal. ◆ Failure in PCB of indoor and outdoor unit results in unstable communication. 					
<p>It is not detected that there is indoor unit connection for 200 rounds continuously; it is detected that the number of indoor units is less than set number for 270 seconds continuously; it is detected that the number of indoor units is more than set number for 170 seconds continuously.</p>					
<ul style="list-style-type: none"> ◆ Poor communication wire: short circuit and disconnection; ◆ Incorrect wiring of communication wire P and Q P and Q; ◆ Poor PCB results poor communication; ◆ Larger interference of normal communication. 					

Failure code Outdoor digital display tube: 27-0, 1 Indoor wired controller: 1B	Indoor unit LED status		LED5		Failure description: Outdoor compressor oil temperature too high failure(Toil1 and Toil2)
	Outdoor unit LED status		20 times		
			LED1	LED2	
		Normal	Normal		
1. Model	Failure diagnosis and troubleshooting				
Flow Logic III series	Diagnosis			Troubleshooting	
2. Abnormity detection method	<pre> graph TD A{Check if the resistance of oil temperature sensor is correct} -- N --> B[Replace the oil temperature sensor by after-sales personnel on site.] A -- Y --> C{Check if the refrigerant in the system is with leakage or insufficient} C -- Y --> D[Replace it correctly by after-sales personnel on site and ensure refrigerant is enough.] C -- N --> E{Check if the outdoor heat exchange is normal when cooling, and check if the indoor heating is normal when heating} E -- N --> F[Replace it correctly by after-sales personnel on site.] E -- Y --> G{Check if the outdoor unit LEVb, SV31 and SV32 can be turned on normally} G -- N --> H[Troubleshoot and replace it correctly by after-sales personnel on site.] G -- Y --> I{Check if it is beyond the allowed operation range of unit.} I -- Y --> J[Use the unit in accordance with its allowed range.] </pre>				
3. Abnormity confirmation conditions					
Toil1/Toil2≥120°C.					
4. Possible causes					
<ul style="list-style-type: none"> ◆ The oil temperature sensor is with resistance drift; ◆ The refrigerant in the system is insufficient; ◆ The outdoor unit LEVb, SV31, SV32, etc. cannot be turned on normally; ◆ The unit condensation side is with poor heat transfer function. ◆ The operation environment is beyond the allowed range. 					

Failure code Outdoor digital display tube: 28-0, 1 Indoor wired controller: 1C	Indoor unit LED status	LED5		Failure description: High pressure sensor disconnection failure
		20 times		
	Outdoor unit LED status	LED1	LED2	
		Normal	Normal	

1. Model	Failure diagnosis and troubleshooting
----------	---------------------------------------

Flow Logic III series	Diagnosis	Troubleshooting
-----------------------	-----------	-----------------

2. Abnormity detection method		
-------------------------------	--	--

<ul style="list-style-type: none"> ◆ Check if the sensor connection is normal; ◆ Check if voltage characteristic of the sensor is normal; ◆ Check if the pressure loop acquired by the PCB is normal. 	<pre> graph TD A{Check if the corresponding connector of sensor is normal} -- N --> B[Replace it correctly by after-sales personnel on site.] A -- Y --> C{Check if the voltage characteristic of the sensor is normal} C -- N --> D[Replace it correctly by after-sales personnel on site.] C -- Y --> E{Check if the pressure loop acquired by the computer board is normal} E -- Y --> F[Replace it correctly by after-sales personnel on site.] </pre>	
--	---	--

3. Abnormity confirmation conditions		
--------------------------------------	--	--

<p>It is detected that the AD value is below 11 (open circuit) or above 1012 (short circuit) for 30 seconds continuously, and no alarm is given during defrosting and within 3 minutes at the end of defrosting.</p>		
--	--	--

4. Possible causes		
--------------------	--	--

<ul style="list-style-type: none"> ◆ The connection of pressure sensor is not secure; ◆ The pressure sensor is broken; ◆ The pressure acquired by PCB is not accurate. 		
---	--	--

Failure code Outdoor digital display tube: 29 Indoor wired controller: 1D	Indoor unit LED status	LED5		Failure description: Low pressure sensor disconnection failure
		20 times		
	Outdoor unit LED status	LED1	LED2	
		Normal	Normal	

1. Model	Failure diagnosis and troubleshooting	
----------	---------------------------------------	--

Flow Logic III series	Diagnosis	Troubleshooting
-----------------------	-----------	-----------------

2. Abnormity detection method	<pre> graph TD A{Check if the corresponding connector of sensor is normal} -- N --> B[Replace it correctly by after-sales personnel on site.] A -- Y --> C{Check if the voltage characteristic of the sensor is normal} C -- N --> D[Replace it correctly by after-sales personnel on site.] C -- Y --> E{Check if the pressure loop acquired by the computer board is normal} E -- N --> F[Replace it correctly by after-sales personnel on site.] </pre>	
-------------------------------	---	--

- ◆ Check if the sensor connection is normal;
- ◆ Check if voltage characteristic of the sensor is normal;
- ◆ Check if the pressure loop acquired by the PCB is normal.

3. Abnormity confirmation conditions

It is detected that the AD value is below 11 (open circuit) or above 1012 (short circuit) for 30 seconds continuously, and no alarm is given during defrosting and within 3 minutes at the end of defrosting.

4. Possible causes

- ◆ The connection of pressure sensor is not secure;
- ◆ The pressure sensor is broken;
- ◆ The pressure acquired by PCB is not accurate.

Failure code Outdoor digital display tube: 30-0, 1 Indoor wired controller: 1E	Indoor unit LED status		LED5		Failure description: High pressure switch disconnection failure
	Outdoor unit LED status		20 times		
			LED1	LED2	
		Normal	Normal		
1. Model	Failure diagnosis and troubleshooting				
Flow Logic III series	Diagnosis			Troubleshooting	
2. Abnormity detection method	<pre> graph TD A{Check if the corresponding connector of pressure switch is normal} -- N --> B[Replace it correctly by after-sales personnel on site.] A -- Y --> C{Check if the pressure switch signal loop acquired by the computer board is normal} C -- Y --> D[Replace it correctly by after-sales personnel on site.] C -- N --> E{Check if the high pressure reaches 4.0MPa when the pressure switch is turned off} E -- Y --> F{Check if the high pressure stop valve is turned on or the high pressure side is blocked} F -- Y --> G[Rectify it correctly by after-sales personnel on site.] F -- N --> H{Check the outdoor fan for normal operation when cooling} H -- N --> I[Rectify it correctly by after-sales personnel on site.] H -- Y --> J{Check if the refrigerant is excessive} J -- Y --> K[Rectify it correctly by after-sales personnel on site. [Note] Confirm if non-condensable gases enter the system.] J -- N --> L{Check if it is out of the operating range of units} L -- Y --> M[Notify the user to use it within the operating range of units by after-sales personnel.] </pre>				
3. Abnormity confirmation conditions					
The high pressure switch is turned off for 2s.					
4. Possible causes					
<ul style="list-style-type: none"> ◆ The connection of pressure switch is not secure; ◆ Pressure switch is broken; ◆ The pressure switch signal acquired by the PCB is incorrect; ◆ The high pressure side of the unit is blocked; ◆ The outdoor fan stops operating when cooling; ◆ The refrigerant is excessive; ◆ It is out of the operating range of units. 					

Failure code Outdoor digital display tube: 31 Indoor wired controller: 1F	Indoor unit LED status	LED5		Failure description: P1 pressure sensor disconnection failure
		20 times		
	Outdoor unit LED status	LED1	LED2	
		Normal	Normal	

Flow Logic III series	Diagnosis	Troubleshooting	
2. Abnormality detection method	<pre> graph TD D1{Check if it is a model with pressure relief device and the DIP switch is correct} D2{Check if the corresponding connector of sensor is normal} D3{Check if the voltage characteristic of the sensor is normal} D4{Check if the pressure loop acquired by the computer board is normal} D1 -- Y --> D2 D2 -- Y --> D3 D3 -- Y --> D4 D1 -- N --> T1[Reset the DIP switch BM4-7 and BM4-8 on site and energize and reset it by after-sales personnel.] D2 -- N --> T2[Replace it correctly by after-sales personnel on site.] D3 -- N --> T3[Replace it correctly by after-sales personnel on site.] D4 -- N --> T4[Replace it correctly by after-sales personnel on site.] </pre>		
<ul style="list-style-type: none"> ◆ Check if the dip switch is set as a model with pressure relief device for ordinary model. ◆ Check if the sensor connection is normal; ◆ Check if resistance characteristic of the sensor is normal; ◆ Check if the temperature loop acquired by the PCB is normal. 			
3. Abnormality confirmation conditions			
It is detected that the AD value is below 11 (open circuit) or above 1012 (short circuit) for 30 seconds continuously, and no alarm is given during defrosting and within 3 minutes at the end of defrosting (shielded by ordinary model).			
4. Possible causes			
<ul style="list-style-type: none"> ◆ The dip switch is set as a model with pressure relief device for ordinary model. ◆ The connection of sensor is not secure; ◆ The sensor is broken; ◆ The pressure signal acquired by PCB is not accurate. 			

FFailure code Outdoor digital display tube: 32-0, 1 Indoor wired controller: 20	Indoor unit LED status	LED5		Failure description: Defrosting temperature sensor failure: Tsc0 and Tliqsc
		20 times		
	Outdoor unit LED status	LED1	LED2	
		Normal	Normal	
1. Model	Failure diagnosis and troubleshooting			
Flow Logic III series	Diagnosis	Troubleshooting		
2. Abnormity detection method	<pre> graph TD D1{Check if the corresponding connector of sensor is normal} D2{Check if resistance temperature characteristic of the sensor is normal} D3{Check if the temperature loop acquired by the computer board is abnormal} D1 -- Y --> D2 D1 -- N --> T1[ReReplace it correctly by after-sales personnel on site.] D2 -- Y --> D3 D2 -- N --> T2[Replace it correctly by after-sales personnel on site.] D3 -- N --> T3[Replace it correctly by after-sales personnel on site.] style T1 fill:none,stroke:none style T2 fill:none,stroke:none style T3 fill:none,stroke:none </pre>			
3. Abnormity confirmation conditions				
It is detected that the AD value is below 11 (open circuit) or above 1012 (short circuit) for 60 seconds continuously, the cooling mode operates the sensor abnormity without troubleshooting it, and no alarm is given during defrosting and within 3 minutes at the end of defrosting.				
4. Possible causes				
<ul style="list-style-type: none"> ◆ The connection of sensor is not secure; ◆ The sensor is broken; ◆ The sensor is with resistance drift; ◆ The temperature acquired by PCB is not accurate. 				

Failure code Outdoor digital display tube: 33-0, 1, 2 Indoor wired controller: 21	Indoor unit LED status		LED5		Failure description: EEPROM (AT24C04) failure
	Outdoor unit LED status		20 times		
			LED1	LED2	
	Normal		Normal		
1. Model	Diagnosis and troubleshooting				
Flow Logic III series	Diagnosis			Troubleshooting	
2. Abnormity detection method	<pre> graph TD A{Turn BM1_1 and M1_2 to "OFF", energize again, and then check if the failure is cleared.} -- Y --> B{Replace EE.} </pre>				
◆ Incorrect EEPROM data.					
3. Abnormity confirmation conditions					
EEPROM communication error; EEPROM data check error (model ID, checksum, etc.); EEPROM data logic error (wider data range, wrong order, etc.)					
4. Possible causes	◆ EEPROM is an old version, while the program is a new version.				

Failure code Outdoor digital display tube: 34-0, 1 Indoor wired controller: 22	Indoor unit LED status		LED5		Failure description: Outdoor compressor discharging temperature (Td1, Td2).too high failure
			20 times		
	Outdoor unit LED status		LED1	LED2	
		Normal	Normal		
1. Model	Diagnosis and troubleshooting				
Flow Logic III series	Diagnosis		Troubleshooting		
2. Abnormity detection method	<pre> graph TD D1{Check if the resistance of discharging temperature sensor is correct.} D2{Check if the refrigerant in the system is with leakage or insufficient.} D3{Check if the outdoor heat exchange is normal when cooling, and check if the indoor heat exchange is normal when heating.} D4{Check if the outdoor unit LEVb, SV31 and SV32 cannot be turned on normally.} D5{Check if the allowed operation range is exceeded.} B1[Use the unit in accordance with its allowed operation range.] D1 -- N --> T1[Replace the discharging temperature sensor by after-sales personnel on site.] D1 -- Y --> D2 D2 -- N --> T2[Replace it correctly by after-sales personnel on site and ensure the refrigerant is enough.] D2 -- Y --> D3 D3 -- N --> T3[Replace it correctly by after-sales personnel on site.] D3 -- Y --> D4 D4 -- N --> T4[Troubleshoot and replace it correctly by after-sales personnel on site.] D4 -- Y --> D5 D5 -- Y --> B1 </pre>				
3. Abnormity confirmation conditions					
Toil1/Toil2≥120°C.					
4. Possible causes					
<ul style="list-style-type: none"> ◆ The oil temperature sensor is with resistance drift; ◆ The refrigerant in the system is insufficient; ◆ The outdoor unit LEVb, SV31 and SV32 cannot be turned on normally. ◆ The unit condensation side is with poor heat transfer function; ◆ The operation environment is beyond the allowed range. 					

Failure code Outdoor digital display tube: 35-0, 1 Indoor wired controller: 23	Indoor unit LED status		LED5		Failure description: 35-0, 1 four-way valve reversing failure
	Outdoor unit LED status		20 times		
			LED1	LED2	
		Normal	Normal		
1. Model	Diagnosis and troubleshooting				
Flow Logic III series	Diagnosis		Troubleshooting		
2. Abnormality detection method	<pre> graph TD A{Check if the difference between high and low pressure of system exceeds 0.6MPa after start and before failure alarm} -- N --> B{Check if the refrigerant in the system is with leakage or insufficient.} B -- Y --> B1[Replace it correctly after sales on site and ensure the refrigerant is enough.] B -- N --> C{Check if the detection value of low pressure sensor is correct.} C -- Y --> C1[Troubleshoot if the detection value of Tsuc or Tdef1/2 sensor is correct and if the connection is correct. Rectify it correctly by after-sales personnel on site.] C -- N --> D{Check if the four-way valve of outdoor unit is with backflow and if the suction pipe filter of compressor is blocked.} D -- Y --> D1[Troubleshoot and rectify it correctly by after-sales personnel on site.] D -- N --> E{Check if it operates normally after replacing with a normal driver module.} E -- N --> E1[Replace the driver module correctly.] E -- Y --> F{Check if the allowed operation range is exceeded.} F -- Y --> F1[Use the unit in accordance with its allowed operation range.] </pre>				
3. Abnormality confirmation conditions					
4. Possible causes					
<ul style="list-style-type: none"> ◆ Check if the difference between high and low pressure of system exceeds 0.6MPa after start and before failure alarm. ◆ Check if the unit lack of refrigerant. ◆ Check the four-way valve of unit for normal switching and free from backflow. ◆ Check if the detection value of high/low pressure sensor is correct. ◆ Check if the unit is beyond the operation range. 					
<p>In case of meeting one of the following conditions after the four-way valve is energized for 3min and lasts for 10s, it is judged as switching completion:</p> <ul style="list-style-type: none"> •$T_{suc}-T_{def}\geq 10^{\circ}C$ •$P_d-P_s\geq\beta MPa$ ($T_{ao}>-10^{\circ}C, \beta=0.60; T_{ao}\leq-10^{\circ}C, \beta=0.40$), otherwise, it is judged as failure. 					
<ul style="list-style-type: none"> ◆ The detection value of high/low pressure sensor is incorrect; ◆ The refrigerant in the system is insufficient; ◆ The four-way valve cannot be switched normally or with backflow. ◆ The filter of compressor suction pipe is blocked by foreign matters; ◆ The detection value of T_{suc} or $T_{def1/2}$ sensor is incorrect; The power module cannot drive the compressor operating normally; ◆ The operation environment is beyond the allowed range. 					

Failure code Outdoor digital display tube: 36-0, 1 Indoor wired controller: 24	Indoor unit LED status	LED5		Failure description: Outdoor compressor oil temperature (Toil1, Toil2) too low failure
		20 times		
	Outdoor unit LED status	LED1	LED2	
		Normal	Normal	
1. Model	Diagnosis and troubleshooting			
Flow Logic III series	Diagnosis	Troubleshooting		
2. Abnormity detection method	<pre> graph TD D1{Check if the resistance of oil temperature sensor is correct.} -- N --> T1[Replace the oil temperature sensor by after-sales personnel on site.] D1 -- Y --> D2{Check if the sensor probe is secure and if the position is correct.} D2 -- N --> T2[Replace it correctly by after-sales personnel on site. [Note]: Check if it is inserted, connected and intersected with another compressor, especially when a single compressor operates.] D2 -- Y --> D3{Check if the indoor unit LEV of "OFF" is closed tightly and if the indoor unit fan of "ON" is normal.} D3 -- N --> T3[Replace the poor valve (with leakage) and fan correctly by after-sales personnel on site.] D3 -- Y --> D4{Check if the terminal of outdoor unit LEVb, SV31 and SV32 is connected properly or is closed tightly.} D4 -- N --> T4[Replace the poor valve (with leakage) and fan correctly by after-sales personnel on site.] D4 -- Y --> D5{Check if the outdoor unit LEVa1, 2 and LEVb are connected properly and correctly when heating} D5 -- N --> T5[Replace it correctly by after-sales personnel on site.] D5 -- Y --> D6{Check if the unit is filled with excessive refrigerant.} D6 -- N --> T6[Check if the computer board can normally control the related electronic expansion valve and solenoid valve, if not, replace it.] D6 -- Y --> F[Fill with regular refrigerant in accordance with standard quantity.] </pre>			
3. Abnormity confirmation conditions				
Toil1/Toil2-CT≤10°C lasts for 5min.				
4. Possible causes				
<ul style="list-style-type: none"> ◆ The probe of oil temperature sensor falls off or is with unsecure connection; ◆ The probe of oil temperature sensor is misplaced; ◆ The oil temperature sensor is with resistance drift; ◆ The outdoor unit LEVb, SV31 and SV32 are with leakage; ◆ The terminal of outdoor unit LEVa1, 2 and LEVb is connected incorrectly; ◆ For the unit, there is LEV leakage in shutdown indoor unit and non-operation of fan in operating indoor unit; ◆ The system refrigerant is too much ◆ The operation environment is beyond the allowed range. 				

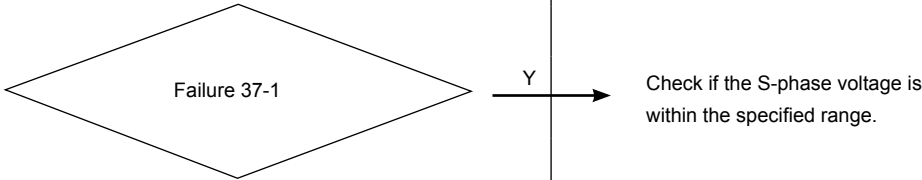
Failure code Outdoor digital display tube: 37-1 Indoor wired controller: 25	Indoor unit LED status	LED5		Failure description: Three-phase power supply S-phase loss
		20 times		
	Outdoor unit LED status	LED1	LED2	
Normal		Normal		
1. Model	Diagnosis and troubleshooting			
Flow Logic III series	Diagnosis		Troubleshooting	
2. Abnormity detection method				
◆ S-phase loss error				
3. Abnormity confirmation conditions				
S-phase loss 37-1				
4. Possible causes				
◆ Power supply S-phase loss				

Failure code Outdoor digital display tube: 39-0 Indoor wired controller: 27	Indoor unit LED status	LED5		Failure description: Low-pressure too low failure
		20 times		
	Outdoor unit LED status	LED1	LED2	
Normal		Normal		
1. Model	Diagnosis and troubleshooting			
Flow Logic III series	Diagnosis	Troubleshooting		
2. Abnormity detection method	<pre> graph TD A{Check if the low pressure of system is below 0.05MPa before failure alarm;} -- Y --> B{Check if the refrigerant in the system is with leakage or insufficient.} B -- Y --> B1[Replace it correctly by after-sales personnel on site and ensure the refrigerant is enough.] B -- N --> C{Check if the detection value of low pressure sensor is correct.} C -- N --> C1[Rectify it correctly by after-sales personnel on site.] C -- Y --> D{Check if the pipelines on the low pressure side or liquid side of the unit are blocked.} D -- Y --> D1[Troubleshoot and rectify it correctly by after-sales personnel on site. [Note]: Check if all stop valves can be turned on and if the air-returning pipe filter of compressor is blocked.] D -- N --> E{Check if the allowed operation range is exceeded.} E -- N --> E1[Check if all the electronic expansion valves of the indoor unit can be turned on normally.] E -- Y --> E2[Use the unit in accordance with its allowed operation range.] </pre>			
3. Abnormity confirmation conditions				
Alarm to shut down if the followings are detected for 5min: cooling: $P_s < 0.10\text{Mpa}$; heating: $P_s < 0.05\text{Mpa}$; oil return: $P_s < 0.03\text{Mpa}$ after the compressor operates. (except residual operation)				
4. Possible causes				
<ul style="list-style-type: none"> ◆ The detection value of low pressure sensor is incorrect; ◆ The refrigerant in the system is insufficient or the system is with air leakage; ◆ The pipelines on the low pressure side or liquid side of the unit are blocked; ◆ The outdoor unit cannot be turned on normally due to failure to open electronic expansion of outdoor heat exchanger when heating; ◆ The operation environment is beyond the allowed range. 				

Failure code Outdoor digital display tube: 39-1 Indoor wired controller: 27	Indoor unit LED status		LED5		Failure description: The unit compression ratio too high failure
	Outdoor unit LED status		20 times		
			LED1	LED2	
		Normal	Normal		
1. Model	Diagnosis and troubleshooting				
Flow Logic III series	Diagnosis			Troubleshooting	
2. Abnormity detection method	<pre> graph TD A{Check if the system operating compression ratio is above 8 before failure alarm.} -- Y --> B{Check if the refrigerant in the system is with leakage or insufficient.} A -- N --> C{Check if the detection value of high-low pressure sensor is correct.} B -- Y --> B1[Use the unit in accordance with its allowed operation range.] B -- N --> C C -- N --> C1[Rectify it correctly by after-sales personnel on site.] C -- Y --> D{Check if the pipelines on the low pressure side or liquid side of the unit are blocked.} D -- Y --> D1[Troubleshoot and rectify it correctly by after-sales personnel on site. [Note]: Simultaneously, check if all stop valves can be turned on.] D -- N --> E{Check if the allowed operation range is exceeded.} E -- N --> E1[Check if all the electronic expansion valves of the indoor unit can be turned on normally.] E -- Y --> E2[Use the unit in accordance with its allowed operation range.] </pre>				
3. Abnormity confirmation conditions					
Alarm to shut down if the compression ratio $\epsilon > 8.0$ is detected for continuous 5min after the compressor operates; alarm to shut down if the compression ratio $\epsilon > 9.0$ or $\epsilon > 8.5$ when cooling or heating for 1min separately.					
4. Possible causes					
<ul style="list-style-type: none"> ◆ The detection value of high/low pressure sensor is incorrect; ◆ The refrigerant in the system is insufficient or the system is with air leakage; ◆ The pipelines on the high pressure side or liquid side of the unit are blocked; ◆ The outdoor unit cannot be turned on normally due to failure to open electronic expansion of outdoor heat exchanger when heating; ◆ The operation environment is beyond the allowed range. 					

Failure code Outdoor digital display tube: 39-2, 3 Indoor wired controller: 27	Indoor unit LED status		LED5		Failure description: The unit compression ratio too low failure
	Outdoor unit LED status		20 times		
			LED1	LED2	
		Normal	Normal		
1. Model	Diagnosis and troubleshooting				
Flow Logic III series	Diagnosis			Troubleshooting	
2. Abnormity detection method					
3. Abnormity confirmation conditions					
Alarm to shut down if the $\varepsilon < 1.8$ is detected for 5min during normal operation (except start, defrosting, oil return, residual, shutdown)					
4. Possible causes					
<ul style="list-style-type: none"> ◆ The detection value of high/low pressure sensor is incorrect; ◆ The refrigerant in the system is insufficient or the system is with air leakage; ◆ The four-way valve cannot be switched normally or with backflow. ◆ The filter of compressor suction pipe are blocked by foreign matters; The power module cannot drive the compressor operating normally; ◆ The inverter compressor is with serious inter deterioration, which makes it difficult to form difference between high and low pressure. ◆ The operation environment is beyond the allowed range. 					

Failure code Outdoor digital display tube: 40-0, 1 Indoor wired controller: 28	Indoor unit LED status		LED5		Failure description: High pressure too high failure
	Outdoor unit LED status		20 times		
			LED1	LED2	
		Normal	Normal		
1. Model	Diagnosis and troubleshooting				
Flow Logic III series	Diagnosis			Troubleshooting	
2. Abnormity detection method	<pre> graph TD D1{Check if the voltage characteristic of the corresponding pressure sensor is normal.} D2{Check if the pressure sensor signal acquisition loop of the computer board is normal.} D3{Check if the high pressure reaches 4.0MPa upon failure alarm.} D4{Check if the high pressure stop valve is turned on or the high pressure side is blocked.} D5{Check the outdoor fan for normal operation when cooling.} D6{Check if the refrigerant is excessive.} D7{Check if the allowed operation range is exceeded.} D1 -- N --> T1[Replace it correctly by after-sales personnel on site.] D1 -- Y --> D2 D2 -- N --> T2[Replace it correctly by after-sales personnel on site.] D2 -- Y --> D3 D3 -- Y --> D4 D3 -- N --> T3[Rectify it correctly by after-sales personnel on site.] D4 -- Y --> T4[Rectify it correctly by after-sales personnel on site.] D4 -- N --> D5 D5 -- N --> T5[Rectify it correctly by after-sales personnel on site.] D5 -- Y --> D6 D6 -- Y --> T6[Rectify it correctly by after-sales personnel on site. Note: confirm if the system including the noncondensable gas] D6 -- N --> D7 D7 -- Y --> T7[Notify the user to use it within the operating range of units by after-sales personnel.] D7 -- N --> T8[] </pre>				
3. Abnormity confirmation conditions					
The high pressure switch is turned off for 2s.					
4. Possible causes					
<ul style="list-style-type: none"> ◆ The pressure sensor is broken; ◆ The pressure sensor signal acquired by the PCB is incorrect; ◆ The high pressure side of the unit is blocked; ◆ The outdoor fan stops operating when cooling; ◆ The refrigerant is excessive; ◆ It is out of the operating range of units. 					

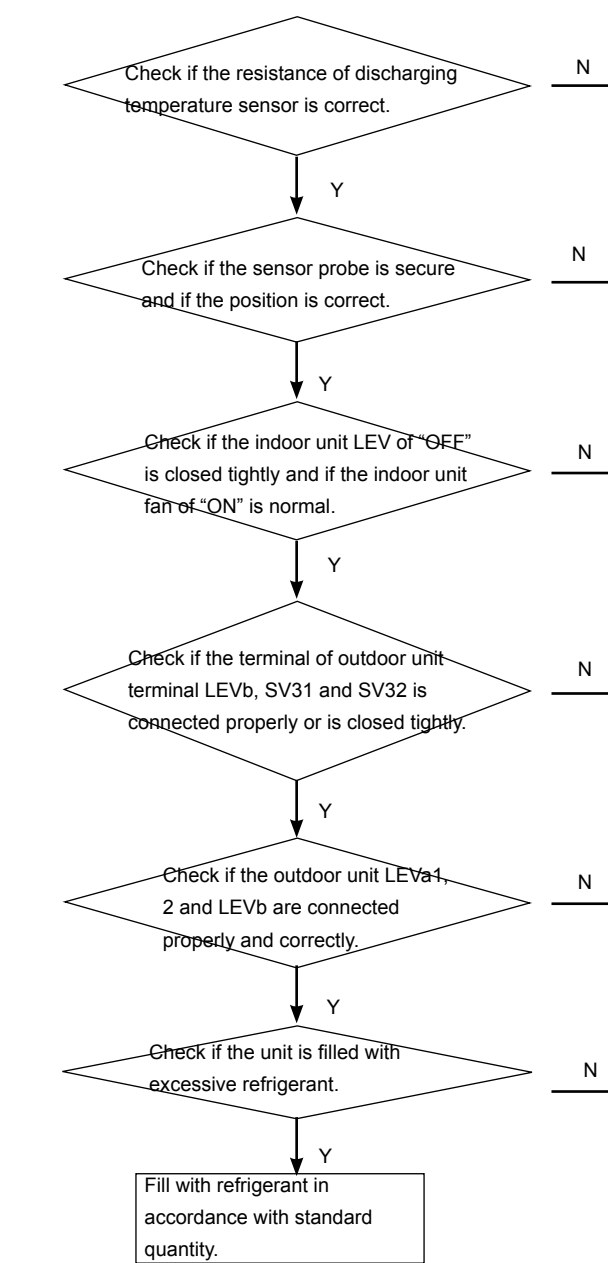
Failure code Outdoor digital display tube: 43-0, 1 Indoor wired controller: 2B	Indoor unit LED status		LED5		Failure description: Outdoor unit compressor discharging temperature (Td1, Td2).too low failure
			20 times		
	Outdoor unit LED status		LED1	LED2	
		Normal	Normal		
1. Model	Diagnosis and troubleshooting				
Flow Logic III series	Diagnosis			Troubleshooting	
2. Abnormity detection method					
3. Abnormity confirmation conditions					
Td1/Td2-CT≤10°C lasts for 5min.					
4. Possible causes					
<ul style="list-style-type: none"> ◆ The probe of oil temperature sensor falls off or is with unsecure connection; ◆ The probe of oil temperature sensor is misplaced; ◆ The oil temperature sensor is with resistance drift; ◆ The outdoor unit LEVb, SV31 and SV32 are with leakage; ◆ The terminal of outdoor unit LEVa1, 2 and LEVb is connected incorrectly; ◆ For the unit, there is LEV leakage in shutdown indoor unit and non-operation of fan in operating indoor unit; ◆ The system is filled with excessive refrigerant. ◆ The operation environment is beyond the allowed range. 					

Failure code Outdoor digital display tube: 45 Indoor wired controller: 2D	Indoor unit LED status	LED5		Failure description: Communications between outdoor units failure.
		20 times		
	Outdoor unit LED status	LED1	LED2	
		Normal	Normal	
1. Model	Diagnosis and troubleshooting			
Flow Logic III series	Diagnosis		Troubleshooting	
2. Abnormity detection method	<pre> graph TD A{Check if the communication wire between the outdoor units is normal.} -- N --> B[Replace it correctly by after-sales personnel on site.] A -- Y --> C{Check if the address DIP switch of outdoor unit is correct.} C -- N --> D[Reset it correctly by after-sales personnel on site.] C -- Y --> E{Check if there is interference source in the position where the outdoor unit is installed.} E -- Y --> F[Clear the interference source.] E -- N --> G{Power off the outdoor unit and research it.} G -- N --> H{Replace the outdoor unit PCB} </pre>			
3. Abnormity confirmation conditions				
No communication for 30s (E)				
4. Possible causes				
<ul style="list-style-type: none"> ◆ Poor communication wire: short circuit or disconnection; ◆ Non-corresponding communication wire A, B and C; ◆ Incorrect connection of outdoor unit communication port of PCB; ◆ Interference source, which causes unstable communication of outdoor unit. 				

Failure code Outdoor digital display tube: 46-0, 1 Indoor wired controller: 2E	Indoor unit LED status	LED5		Failure description: Communication with INV1 and INV2 module board failure
	Outdoor unit LED status	20 times		
		LED1	LED2	
		Normal	Normal	
1. Model	Diagnosis and troubleshooting			
Flow Logic III series	Diagnosis		Troubleshooting	
2. Abnormity detection method	<pre> graph TD A{Check if the interface board is connected with the wiring harness of variable frequency board correctly.} -- N --> B[Replace it correctly by after-sales personnel on site.] A -- Y --> C{Check if the communication wire is disconnected;} C -- Y --> D[Replace it correctly by after-sales personnel on site.] C -- N --> E{Test if the voltage of the two central needles of CN28 and CN57 changes by a multimeter.} E -- Y --> F[Replace the interface board of outdoor unit.] </pre>			
3. Abnormity confirmation conditions				
No communication for 30s				
4. Possible causes				
<ul style="list-style-type: none"> ◆ Poor communication wire: disconnection; ◆ Incorrect correspondence of INV1 and INV2; incorrect connection of outdoor unit communication port of PCB; ◆ Poor inverter board or connection board 				

Failure code Outdoor digital display tube: 71-0, 1 Indoor wired controller: 47	Indoor unit LED status		LED5		Failure description: Fan motor 1 blocked (left fan) Fan motor 2 blocked (right fan)
	Outdoor unit LED status		20 times		
			LED1	LED2	
		Normal	Normal		
1. Model	Diagnosis and troubleshooting				
Flow Logic III series	Diagnosis			Troubleshooting	
2. Abnormity detection method	<pre> graph TD A{Check if the wire harness of fan is connected correctly.} -- N --> B[Replace it correctly by after-sales personnel on site.] A -- Y --> C{Check if the connection wire of fan is connected correctly.} C -- N --> D[Replace it correctly by after-sales personnel on site.] C -- Y --> E{Check if the fan can operate and check if there is resistance when rotating the fan manually.} E -- N --> F[Replace the motor.] E -- Y --> G{Test if the fan is with 310V DC input.} G -- N --> H[Check the power supply and adjust it correctly.] G -- Y --> I{Check if the power supply is with 220V input.} I -- N --> J[Check the power supply and adjust it correctly.] I -- Y --> K{Replace the interface board of outdoor unit.} </pre>				
3. Abnormity confirmation conditions					
4. Possible causes					
<ul style="list-style-type: none"> ◆ Check if the connection wire is correct ◆ Check if the motor fan is with friction; ◆ Check if the DC input of motor is correct. 					
<p>Make failure confirmation three times per hour as follows: below 20rpm, operate for 30s or below 70% of target value, operate for 2min, shut down 2min and automatically recover after 50s.</p>					
<ul style="list-style-type: none"> ◆ Insufficient power supply, which causes motor with lower or higher voltage input; ◆ The rotating speed of fan decreases affected by resistance. 					

Failure code Outdoor digital display tube: 72-0, 1 Indoor wired controller: 48	Indoor unit LED status	LED5		Failure description: Fan motor 1 reverse rotation (left fan) Fan motor 2 reverse rotation (left fan)
	Outdoor unit LED status	20 times		
		LED1	LED2	
		Normal	Normal	
1. Model	Diagnosis and troubleshooting			
Flow Logic III series	Diagnosis		Troubleshooting	
2. Abnormity detection method	<pre> graph TD A{Check if the wire harness of fan is connected correctly.} -- N --> B[Replace it correctly by after-sales personnel on site.] A -- Y --> C{Check if the connection wire U, V and W of fan are in correct order.} C -- N --> D[Adjust it correctly by after-sales personnel on site.] C -- Y --> E{Check if the fan operates reversely driven by the outdoor fan.} E -- N --> F[Adjust it correctly by after-sales personnel on site.] E -- Y --> G([Replace the motor.]) </pre>			
3. Abnormity confirmation conditions				
4. Possible causes				
<ul style="list-style-type: none"> ◆ Check if the connection wire is correct; ◆ Check if the motor fan is rotating reversely, driven by external force. 				
<p>Alarm to shut down if the reverse signal from the fan is detected and the reverse rotation speed is above 700rpm. (overlook the fan, clockwise operation refers to reverse rotation)</p>				
<ul style="list-style-type: none"> ◆ Poor motor drive, which causes reverse rotation of fan; ◆ Reverse rotation of fan affected by external force. 				

Failure code Outdoor digital display tube: 73-0, 1 Indoor wired controller: 49	Indoor unit LED status	LED5		Failure description: Fan motor 1 overcurrent (left fan) Fan motor 2 overcurrent (right fan)
		20 times		
	Outdoor unit LED status	LED1	LED2	
		Normal	Normal	
1. Model	Diagnosis and troubleshooting			
Flow Logic III series	Diagnosis		Troubleshooting	
2. Abnormity detection method	<pre> graph TD A{Check if the wire harness of fan is connected correctly.} -- N --> B[Replace it correctly by after-sales personnel on site.] A -- Y --> C{Check if the voltage input of fan is excessive.} C -- N --> D[Adjust it correctly by after-sales personnel on site.] C -- Y --> E{Check if the air outlet is blocked and if there is resistance.} E -- N --> F[Adjust the air outlet, to make the air flow smooth.] E -- Y --> G{Check if the fan is with wind guide ring.} G -- N --> H[Check the surrounding wind guide ring and adjust it correctly.] G -- Y --> I{Check if the air outlet is blocked and if there is resistance.} I -- Y --> J[Adjust the air outlet, to make the air flow smooth.] I -- N --> K{Check if there is resistance when rotating the fan manually.} K -- Y --> L[Replace the motor.] </pre>			
3. Abnormity confirmation conditions				
Alarm to shut down if overcurrent signal appears when the rotating speed is set as below 400rpm for 10s; make failure confirmation five times per hour.				
4. Possible causes				
<ul style="list-style-type: none"> ◆ Excessive supply voltage; ◆ Larger static pressure of fan. 				

Failure code Outdoor digital display tube: 74 Indoor wired controller: 4A	Indoor unit LED status	LED5		Failure description: Emergency stop function switch failure
		20 times		
	Outdoor unit LED status	LED1	LED2	
Normal		Normal		
1. Model	Diagnosis and troubleshooting			
Flow Logic III series	<p>The outdoor PCB add the function of emergency stop (for new PCB CN19 is this function terminal and for old PCB CN9 is this function terminal) , the logic of the emergency stop is close is normal, and open is stop;</p> <p>Note:</p> <ol style="list-style-type: none"> 1. The spare part PCB doesn't contain the short circuit ring 2. New PCB CN19 is 5 cores terminal 3. Old PCB CN19 is 8 cores terminal <div style="text-align: center;"> <p>If the emergency stop teiminal is short circuit</p> <p>N</p> <p>Short circuit the terminal</p> </div>			
2. Abnormity detection method				
<p>◆ Check if the terminal of emergency stop function (new PCB is CN19, old PCB is CN9) is open circuit</p>				
3. Abnormity confirmation conditions				
4. Possible causes	<p>New PCB</p> <div style="display: flex; align-items: center;"> <div style="margin-right: 10px;"> </div> <div> <p>Shorted position of CN19 is the second and fifth pin</p> </div> </div> <div style="display: flex; align-items: center; margin-top: 10px;"> <div style="margin-right: 10px;"> <p>CN19</p> </div> <div> <p>Short circuit the CN19 by the short circuit ring of 0150402375</p> </div> </div> <div style="display: flex; align-items: center; margin-top: 20px;"> <div style="margin-right: 10px;"> <p>CN9</p> </div> <div> <p>Short circuit the CN9 by the short circuit ring of 0150400260</p> </div> </div> <p>◆ The terminal of emergency stop is open circuit</p>			

Failure code Outdoor digital display tube: 75-0, 4 Indoor wired controller: 4B	Indoor unit LED status	LED5		Failure description: Pressure difference between high and low pressure too low failure
		20 times		
	Outdoor unit LED status	LED1	LED2	
		Normal	Normal	
1. Model	Diagnosis and troubleshooting			
Flow Logic III series	Diagnosis	Troubleshooting		
2. Abnormity detection method	<pre> graph TD A{Check if the high-low pressure difference of system exceeds 0.4MPa after start and before failure alarm;} -- N --> B{Check if the refrigerant in the system is with leakage or insufficient.} B -- Y --> B1[Replace it correctly by after-sales personnel on site and ensure the refrigerant is enough.] B -- N --> C{Check if the detection value of low pressure sensor is correct.} C -- N --> C1[Rectify it correctly by after-sales personnel on site. Check if the corresponding pressure sensor is intersected with another compressor, especially for a double compressor system.] C -- Y --> D{If the four-way valve of outdoor unit is with backflow and if the suction pipe filter of compressor is blocked.} D -- Y --> D1[Troubleshoot and replace it correctly by after-sales personnel on site. [Note]: Check if the suction pipe filter of compressor is blocked, when the discharging temperature rises obviously.] D -- N --> E{Check if it operates normally after replacing a normal driver module.} E -- N --> E1[Replace the driver module correctly.] E -- Y --> F{if the allowed operation range is exceeded.} F -- N --> F1[Replace the inverter compressor if the high-low pressure difference cannot reach 0.4MPa above before failure alarm.] F -- Y --> G[Use the unit in accordance with its allowed operation range.] </pre>			
◆ Check if the difference between high and low pressure of system exceeds 0.4MPa after start and before failure alarm; ◆ Check if the unit lack of refrigerant. ◆ Check the four-way valve of unit for normal switching and free from backflow. ◆ Check if the detection value of high/low pressure sensor is correct. ◆ Check if the unit is beyond the operation range.				
3. Abnormity confirmation conditions				
75-0: Pd-Ps≤0.1Mpa within 1min upon the INV compressor starts. 75-4: Pd-Ps≤0.4Mpa lasts for 3min.				
4. Possible causes				
◆ The detection value of high/low pressure sensor is incorrect; ◆ The refrigerant in the system is insufficient; ◆ The four-way valve cannot be switched normally or with backflow. The power module cannot drive the compressor operating normally; ◆ The inverter compressor is with serious inter deterioration, which makes it difficult to form difference between high and low pressure. ◆ The operation environment is beyond the allowed range.				

Failure code Outdoor digital display tube: 76-0, 1, 2 Indoor wired controller: 4C	Indoor unit LED status	LED5		Failure description: Incorrect settings of quantity, address or power input for outdoor unit
		20 times		
	Outdoor unit LED status	LED1	LED2	
		Normal	Normal	
1. Model	Diagnosis and troubleshooting			
Flow Logic III series	Diagnosis	Troubleshooting		
2. Abnormity detection method	<pre> graph TD D1{Check if the power input of outdoor unit changes.} -- Y --> T1[Research and lock the outdoor unit.] D1 -- N --> D2{Check if the quantity of outdoor unit changes.} D2 -- Y --> T2[Research and lock the outdoor unit.] D2 -- N --> D3{Check if the model number setting of outdoor unit is correct.} D3 -- Y --> T3[Replace it correctly by after-sales personnel on site. Research and lock the unit.] </pre>			
3. Abnormity confirmation conditions				
4. Possible causes				
<ul style="list-style-type: none"> ◆ Check if the quantity of outdoor unit changes; (76-0) ◆ Check if the model number of outdoor unit changes; (76-1) ◆ Check if the power input of outdoor unit changes.(76-2) 				
<ul style="list-style-type: none"> ◆ The quantity of connected unit changes; ◆ The power input of outdoor unit of the same system changes; ◆ The model setting of the same system changes; 				

Failure code Outdoor digital display tube: 77 Indoor wired controller: 4D	Indoor unit LED status	LED5		Failure description: Oil balancing protection failure between outdoor units
		20 times		
	Outdoor unit LED status	LED1	LED2	
Normal		Normal		
1. Model	Failure diagnosis and troubleshooting			
Flow Logic III series	Diagnosis	Troubleshooting		
2. Abnormity detection method	<pre> graph TD A{Turn on or off the SV9/SV10, check if the temperature of Toilp of corresponding outdoor units increases by more than 10°C during oil balancing} -- Y --> B{Check if the SV9/SV10 of corresponding outdoor units can be turned on} A -- N --> B B -- N --> C[Find out the cause why the electromagnetic valve cannot be switched on and rectify it by after-sales personnel on site.] B -- Y --> D{Check if the detection value of Toilp sensor is correct.} D -- N --> E[Check the detection probe of sensors for looseness and the resistance for drift, and rectify it.] D -- Y --> F{Check the solenoid valve for inner leakage when it is switched off} F -- Y --> G[Replace the electromagnetic valve with inner leakage by after-sales personnel.] F -- N --> H{Check the oil balance pipeline of system for blockage} H -- Y --> I[Rectify on site by after-sales personnel. [Note] Check if the oil balance stop valves of outdoor units are opened.] H -- N --> J{Check if the allowed operation range is exceeded} J -- Y --> K[Use the units in accordance with its allowed operation range.] J -- N --> K </pre>			
3. Abnormity confirmation conditions				
Alarm to shut down when ToilpB-ToilpA≤10°C [Note]The ToilpA and ToilpB are the temperatures of oil balance pipe when the oil balance pipe is switched on/off.				
4. Possible causes				
<ul style="list-style-type: none"> ◆ The oil balance electromagnetic valves cannot be switched on; ◆ Inner leakage occurs when the oil balance electromagnetic valves are switched off; ◆ The temperature detected by Toilp sensor is incorrect; ◆ The oil balance pipe is blocked. ◆ The allowed operation range is exceeded and it becomes difficult to switch on the electromagnetic valves due to reinforced oil viscosity caused by low ambient temperature. 				

Failure code Outdoor digital display tube: 78-0, 1 Indoor wired controller: 4E	Indoor unit LED status		LED5		Failure description: Cooling/heating lack of refrigerant alarm
			20 times		
	Outdoor unit LED status		LED1	LED2	
		Normal	Normal		
1. Model	Failure diagnosis and troubleshooting				
Flow Logic III series	Diagnosis			Troubleshooting	
2. Abnormity detection method	<pre> graph TD A{Check the system for refrigerant leakage or insufficiency} -- Y --> B[Rectify on site and ensure sufficient refrigerant by after-sales personnel.] A -- N --> C{Check if the detection value of low pressure sensor is correct.} C -- N --> D[Rectify on site by after-sales personnel.] C -- Y --> E{Check if the allowed operation range is exceeded.} E -- Y --> F[Use the units in accordance with the allowed operation range.] </pre>				
3. Abnormity confirmation conditions					
4. Possible causes					
<ul style="list-style-type: none"> ◆ When the unit stops, confirm if the corresponding temperature upon saturated equilibrium pressure is lower than the outdoor or indoor temperature, whichever is lower; ◆ Check the unit parts for leakage. ◆ Check if the detection value of low pressure sensor is correct. 					
<p>Ps<0.1Mpa runs continually for 30 minutes upon operation of cooling compressor; Ts1-ET>20& Ts1-ET>20°CLEV runs fully-open for 60 minutes upon operation of heating compressor.</p>					
<ul style="list-style-type: none"> ◆ The refrigerant in the system is insufficient or the leakage parts are found; ◆ The detection value of low pressure sensor is incorrect; ◆ The allowed operation range is exceeded. 					

Failure code Outdoor digital display tube: 79 Indoor wired controller: 4F	Indoor unit LED status		LED5		Failure description: Operation protection of incorrect wiring.
	Outdoor unit LED status		20 times		
			LED1	LED2	
		Normal	Normal		
1. Model	Failure diagnosis and troubleshooting				
Flow Logic III series	Diagnosis			Troubleshooting	
2. Abnormity detection method	<pre> graph TD A{Check if the failure alarm meets the alarm requirements for incorrect wiring} -- Y --> B{Check if the detection values of temperature sensors are correct.} B -- Y --> C(Confirm the outdoor and indoor units are wired correctly and rectify by after-sales personnel.) B -- N --> D(Rectify on site by after-sales personnel.) </pre>				
◆ Confirm operation of incorrect wiring					
3. Abnormity confirmation conditions					
After 30-minute detection on incorrect wiring, for outdoor units: display the failure code when $Td2 \leq T_{ao} + 30K$; for indoor units: display the failure code when cooling $Tc2 \geq T_{ai} - 20K$; display the failure code when heating $Tc1 \leq T_{ai} + 20K$.					
4. Possible causes					
◆ The wire connection of outdoor and indoor units are wrong during installation.					

Failure code Outdoor digital display tube: 80 Indoor wired controller: 50	Indoor unit LED status	LED5		Failure description: The HP difference between outdoor units in one system is above 4.
	Outdoor unit LED status	20 times		
		LED1	LED2	
		Normal	Normal	
1. Model	Failure diagnosis and troubleshooting			
Flow Logic III series	Diagnosis	Troubleshooting		
2. Abnormity detection method	<pre> graph TD A{Confirm if the power input difference between combined outdoor units is above 4HP} -- Y --> B[The service manager inform the installer the max HP difference less than 4HP.] A -- N --> C{Check if the HP DIP switch of outdoor units is correctly configured.} C -- N --> D[Rectify on site by after-sales personnel.] C -- Y --> E[Set SW9/SW10/SW11 at 0, 1 and 0 respectively and check if the power input is correct.] E -- N --> F[Replace the PCB of outdoor unit.] </pre>			
3. Abnormity confirmation conditions				
4. Possible causes				
<ul style="list-style-type: none"> ◆ Confirm if the power input difference between combined outdoor units is above 4HP; ◆ Set SW9\SW10\SW11 at 0, 1 and 0 respectively and check if the power input on LED3 and LED4 is correct. 				
<ul style="list-style-type: none"> ◆ The HP difference between outdoor units is above 4 in one system. 				
<ul style="list-style-type: none"> ◆ The power input difference between outdoor units is above 4HP in multi-connected system; ◆ The power input dip switch BM3_5, BM3_6, BM3_7 and BM3_8 of outdoor units is incorrect. 				

Failure code Outdoor digital display tube: 110-0, 1, 1 Indoor wired controller: 6E	Indoor unit LED status		LED5		Failure description: Overcurrent of module 1 and 2
	Outdoor unit LED status		20 times		
			LED1	LED2	
		Normal	Normal		
1. Model	Failure diagnosis and troubleshooting				
Flow Logic III series	Diagnosis			Troubleshooting	
2. Abnormity detection method	<pre> graph TD A{Check if the supply voltage is normal} -- N --> B[Rectify on site by after-sales personnel.] A -- Y --> C{Check if the electrical cabinet and compressor wires are secured, the UVW is correctly connected and the variable frequency board and module board are wired correctly.} C -- N --> D[Rectify on site by after-sales personnel.] C -- Y --> E{Check if the power module is normal} E -- N --> F[Replace on site by after-sales personnel.] E -- Y --> G{Check if there is other failure, 112, 113 and 114} G -- N --> H[Replace the compressor.] G -- Y --> I{Check if the compressor, resistance and insulation are normal} I -- N --> J[Detect by exclusion.] I -- Y --> K[Troubleshoot each failure.] </pre>				
3. Abnormity confirmation conditions					
Overcurrent of module hardware					
4. Possible causes					
<ul style="list-style-type: none"> ◆ Check if the modules are in normal conditions and if P and N are short-circuited to U, V and W. ◆ Check if the modules are fixed securely and the heat dissipation is good; ◆ Check if the compressor resistance is normal, ◆ Check if the compressor wiring UVW is wrongly connected and if the inverter board and module board are wired securely. 					
<ul style="list-style-type: none"> ◆ The module alarms FO failure due to poor heat dissipation; ◆ The module alarms failure as it is broken down; ◆ Liquid shock is found in compressor, which results in overcurrent upon starting or operating; ◆ The winding resistance of compressor is large; ◆ UVW wiring is wrongly connected or the inverter board and module board are wired insecurely. 					

Failure code Outdoor digital display tube: 111-0, 1, 1 Indoor wired controller: 6F	Indoor unit LED status		LED5		Failure description: Overcurrent of module 1 and 2
			20 times		
	Outdoor unit LED status		LED1	LED2	
		Normal	Normal		
1. Model	Failure diagnosis and troubleshooting				
Flow Logic III series	Diagnosis			Troubleshooting	
2. Abnormity detection method	<pre> graph TD D1{Check if the supply voltage is normal} -- N --> T1[Replace on site by after-sales personnel.] D1 -- Y --> D2{Check if the electrical cabinet and compressor wires are secured, the UVW is correctly connected and the variable frequency board and module board are wired correctly.} D2 -- N --> T2[Replace on site by after-sales personnel.] D2 -- Y --> D3{Check if the PWM signals from 6 channels on variable frequency control board and IPM driver board are normal.} D3 -- N --> T3[Replace the variable frequency control board.] D3 -- Y --> D4{Check if the power module is normal} D4 -- N --> T4[Replace the power module.] D4 -- Y --> D5{Check if the compressor, resistance and insulation are normal} D5 -- N --> T5[Replace the compressor.] D5 -- Y --> B1[The compressor is overloading and check for the causes.] </pre>				
3. Abnormity confirmation conditions					
Overcurrent of module hardware					
4. Possible causes					
	<ul style="list-style-type: none"> ◆ The module alarms failure as it broke down; ◆ Liquid shock is found in compressor which results in overcurrent upon starting or operating; ◆ The compressor winding is burned out; ◆ UVW wiring is wrongly connected or the inverter board and module board are wired insecurely. 				

Failure code Outdoor digital display tube: 112-0, 1, 1 Indoor wired controller: 70	Indoor unit LED status	LED5		Failure description: Radiator temperature of module 1 and 2 is too high.
		20 times		
	Outdoor unit LED status	LED1	LED2	
		Normal	Normal	
1. Model	Failure diagnosis and troubleshooting			
Flow Logic III series	Diagnosis		Troubleshooting	
2. Abnormity detection method	<pre> graph TD A{Check if the cooling fan rotates and the sensor is normal} -- N --> B[Troubleshoot the fan and PCB terminal for 220V voltage output.] A -- Y --> C{Check if the module is secured and the cooling silica gel is even up} C -- N --> D[Secure the module and paint with radiating silica gel evenly.] C -- Y --> E{Check if 110, 113 and 114 failure is found} E -- N --> F[Troubleshoot and replace the power module.] E -- Y --> G([Troubleshoot each failure]) </pre>			
3. Abnormity confirmation conditions				
Raise failure alarm when temperature $\geq 94^{\circ}\text{C}$. INV control board recovers automatically when temperature $\leq 94^{\circ}\text{C}$.				
4. Possible causes				
<ul style="list-style-type: none"> ◆ The module is insecurely fixed, which results in poor heat dissipation; ◆ The radiator sensor is broken which results in high detection temperature; ◆ The cooling fan fails to operate; ◆ There is no 220V output from the terminal of cooling fan of PCB. 				

Failure code Outdoor digital display tube: 113-0,1 Indoor wired controller: 71	Indoor unit LED status		LED5		Failure description: Overload of module 1 and 2
	Outdoor unit LED status		20 times		
			LED1	LED2	
		Normal	Normal		
1. Model	Failure diagnosis and troubleshooting				
Flow Logic III series	Diagnosis			Troubleshooting	
2. Abnormity detection method	<pre> graph TD A{Check the compressor for overloading and liquid-returning.} -- N --> B[Improve the cooling system.] A -- Y --> C{Check if the electrical capacitor is connected correctly} C -- N --> D[Reconnect or replace the capacitor.] C -- Y --> E([Troubleshoot and replace the neighboring power module.]) </pre>				
3. Abnormity confirmation conditions					
Module overload					
4. Possible causes					
◆ There is a problem of heating tape of compressor that the compressor forcibly starts without heating or with inadequate heating time; ◆ The capacitor and PTC may be incorrectly connected.					

Failure code Outdoor digital display tube: 114-0,1 Indoor wired controller: 72	Indoor unit LED status		LED5		Failure description: DC under voltage of module 1 and 2
	Outdoor unit LED status		20 times		
			LED1	LED2	
		Normal	Normal		
1. Model	Failure diagnosis and troubleshooting				
Flow Logic III series	Diagnosis			Troubleshooting	
2. Abnormity detection method	<pre> graph TD A{Check if the supply voltage is normal and the cabinet is wired correctly.} -- N --> B[Adjust the supply voltage or rewire the cabinet in accordance with circuit diagram.] A -- Y --> C{Check if the power relay and PTC is contacted.} C -- N --> D[Adjust or replace the power relay.] C -- Y --> E{Test if the voltage of DC bus is below 420V.} E -- Y --> F[The detection circuit of variable frequency board is damaged, replace the board.] E -- N --> G[Replace and compare the neighboring electrical cabinet by troubleshooting.] </pre>				
3. Abnormity confirmation conditions					
Raise failure alarm when power voltage < DC420V. INV control board recovers automatically when voltage > DC420V					
4. Possible causes					
<ul style="list-style-type: none"> ◆ Incorrect wiring may result in under voltage alarm; ◆ PTC or relay damage may result in under voltage; ◆ Low power voltage may result in under voltage. 					

Failure code Outdoor digital display tube: 115-0,1 Indoor wired controller: 73	Indoor unit LED status	LED5		Failure description: DC over-voltage of module 1 and 2	
	Outdoor unit LED status	20 times			
		LED1	LED2		
		Normal	Normal		
1. Model	Failure diagnosis and troubleshooting				
Flow Logic III series	Diagnosis		Troubleshooting		
2. Abnormity detection method	<pre> graph TD A{Check if the supply voltage is normal.} -- N --> B[Adjust the supply voltage.] A -- Y --> C{Check if the cabinet is wired correctly.} C -- N --> D[Rewire the cabinet in accordance with wiring diagram.] C -- Y --> E{Test if the voltage of DC bus is above 642V.} E -- Y --> F[The detection circuit of variable frequency board is damaged. Replace the board.] E -- N --> G(Replace and compare the neighboring electrical cabinet by troubleshooting.) </pre>				
3. Abnormity confirmation conditions					
Raise failure alarm when power voltage > DC642V. INV control board recovers automatically when voltage < DC642V.					
4. Possible causes					
◆ Incorrect connection may result in over voltage alarm; ◆ High power voltage may result in over voltage.					

Failure code Outdoor digital display tube: 116-0, 1 Indoor wired controller: 74	Indoor unit LED status		LED5		Failure description: Communication failure of module 1 and 2
	Outdoor unit LED status		20 times		
			LED1	LED2	
		Normal	Normal		
1. Model	Failure diagnosis and troubleshooting				
Flow Logic III series	Diagnosis			Troubleshooting	
2. Abnormity detection method	<pre> graph TD A{Check if the main control board and variable frequency board is wired correctly.} -- N --> B[Adjust the wires between main control board and variable frequency board.] A -- Y --> C{Check if the communication circuit of main control board is normal.} C -- N --> D[Replace the main control board.] C -- Y --> E{Check if the circuit of variable frequency board is normal.} E -- N --> F[Replace the variable frequency board.] E -- Y --> G[Replace and compare the neighboring cabinet by exclusion method.] </pre>				
3. Abnormity confirmation conditions					
Failure alarm if communication signal fails to be detected for continuous 30s and INV control board recovers immediately upon signal detection.					
4. Possible causes					
◆ Poor communication of inverter board or main control board.					

Failure code Outdoor digital display tube: 117-0,1 Indoor wired controller: 75	Indoor unit LED status		LED5		Failure description: Software overcurrent of module 1 and 2
	Outdoor unit LED status		20 times		
			LED1	LED2	
		Normal	Normal		
1. Model	Failure diagnosis and troubleshooting				
Flow Logic III series	Diagnosis			Troubleshooting	
2. Abnormity detection method	<pre> graph TD A{Check if the supply voltage is normal.} -- N --> B[Adjust the supply voltage.] A -- Y --> C{Check if the electrical cabinet is wired correctly, the compressor matches U, V and W correctly and the variable frequency board and module board is connected securely.} C -- N --> D[Readjust wiring and fixing method in accordance with the circuit diagram.] C -- Y --> E{Check if the power module is normal.} E -- N --> F[Replace the power module.] E -- Y --> G{Check if the detection circuit of variable frequency board is normal.} G -- N --> H[Replace the variable frequency board.] G -- Y --> I{Check if the winding and insulation of compressor is normal.} I -- N --> J[Replace the compressor.] I -- Y --> K[Replace and compare the neighboring electrical cabinet by Exclusion method.] </pre>				
3. Abnormity confirmation conditions					
Overcurrent of module software					
4. Possible causes					
<ul style="list-style-type: none"> ◆ Check if the compressor is insecurely connected; ◆ Check the system for liquid shock. ◆ Check if the module is in normal conditions and subject to short circuit. ◆ Check if the compressor is well. ◆ Check if the compressor wiring UVW is connected correctly and the inverter board and module board is securely wired. 					
<ul style="list-style-type: none"> ◆ The current detection loop of inverter board is in poor performance, which results in rapid current rise of compressor; ◆ Damage or liquid shock is found in compressor, which results in overcurrent; ◆ UVW wiring is wrongly connected or the inverter board and module board are wired insecurely. 					

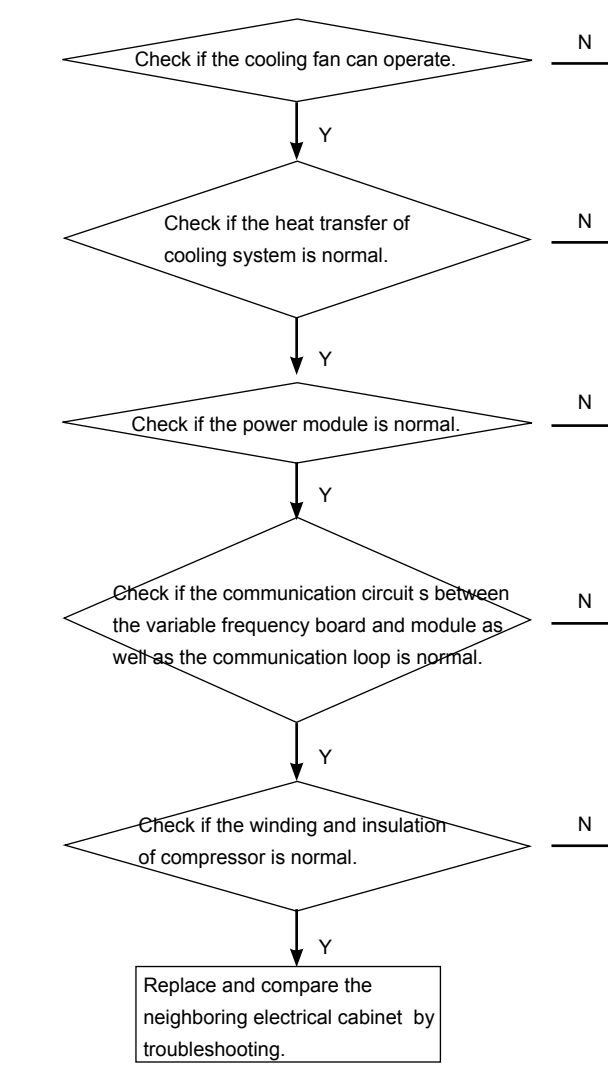
Failure code Outdoor digital display tube: 118-0, 1 Indoor wired controller: 76	Indoor unit LED status		LED5		Failure description: Start failure of module 1 and 2
	Outdoor unit LED status		20 times		
			LED1	LED2	
		Normal	Normal		
1. Model	Failure diagnosis and troubleshooting				
Flow Logic III series	Diagnosis			Troubleshooting	
2. Abnormity detection method	 <pre> graph TD A{Check if the cooling fan can operate.} -- N --> B[Adjust or replace the cooling fan to allow operation.] A -- Y --> C{Check if the heat transfer of cooling system is normal.} C -- N --> D[Check the corresponding installation environment.] C -- Y --> E{Check if the power module is normal.} E -- N --> F[Replace the power module.] E -- Y --> G{Check if the communication circuit s between the variable frequency board and module as well as the communication loop is normal.} G -- N --> H[Replace the variable frequency board or secure the connection wire.] G -- Y --> I{Check if the winding and insulation of compressor is normal.} I -- N --> J[Replace the compressor.] I -- Y --> K[Replace and compare the neighboring electrical cabinet by troubleshooting.] </pre>				
<ul style="list-style-type: none"> ◆ Check if the compressor is insecurely connected; ◆ Check the system for liquid shock and poor heat dissipation. ◆ Check if the compressor and modules are well. ◆ Check if the inverter board and module is insecurely connected or inserted. 					
3. Abnormity confirmation conditions	The module is found with limiting current or overheating protection.				
4. Possible causes	<ul style="list-style-type: none"> ◆ The inverter board and module are wired insecurely, which results in failure alarm due to failure to detect compressor rotation speed. ◆ The compressor or the power module is damaged. 				

Failure code Outdoor digital display tube: 119-0, 1 Indoor wired controller77	Indoor unit LED status	LED5		Failure description: The current detection of inverter control board 1 and 2 is abnormal	
	Outdoor unit LED status	20 times			
		LED1	LED2		
		Normal	Normal		
1. Model	Failure diagnosis and troubleshooting				
Flow Logic III series	Diagnosis	Troubleshooting			
2. Abnormity detection method					
3. Abnormity confirmation conditions					
4. Possible causes					
<ul style="list-style-type: none"> ◆ Check if the current sensor is reversely connected and U and W is in reverse direction. ◆ Check if the current sensor is in reverse direction. (the arrow on sensor points at the compressor) ◆ Check if the inverter board is well. ◆ Check if the current sensor is well. 					
<p>The current detection sensor of inverter control board is in abnormal conditions, disconnected or connected incorrectly.</p>					
<ul style="list-style-type: none"> ◆ The inverter board and current sensor is anti-connected or the current sensor is in incorrect direction. ◆ The inverter board or current sensor is damaged. 					

To be continued

Failure code Outdoor digital display tube: 119-0, 1 Indoor wired controller77	Indoor unit LED status		LED5		Failure description: The current detection of inverter control board 1 and 2 is abnormal
	Outdoor unit LED status		20 times		
			LED1	LED2	
		Normal	Normal		
1. Model	Failure diagnosis and troubleshooting				
Flow Logic III series	Diagnosis			Troubleshooting	
2. Abnormity detection method	<pre> graph TD D1{Check if there is audible sound when the compressor starts before the 119 failure alarm. (Note: the duration is about 1s.)} D2{After power supply and upon compressor start, test the DC voltage between the second pin (black, earth wire) and third pin (brown, signal wire) of the wiring harness terminal of the two current sensors, confirm if the signal voltage is between 1V and 5V?} D3{Confirm if the wiring harness between inverter control board CN10 and module driver board CNDR15V1 is reliably connected?} D4{Confirm if the wiring harness between inverter control board CN9 and module driver board CNDR1 is reliably connected?} D1 -- N --> T1[Replace the inverter control board with abnormal current detection loop.] D1 -- Y --> D2 D2 -- N --> T2[Replace the current sensor with abnormal signal voltage.] D2 -- Y --> D3 D3 -- N --> T3[Correct the wrong connection.] D3 -- Y --> D4 D4 -- N --> T4[Correct the wrong connection.] D4 -- Y --> End[] style End fill:none,stroke:none </pre>				
3. Abnormity confirmation conditions					
The current detection sensor of inverter control board is in abnormal conditions, disconnected or connected incorrectly.					
4. Possible causes					
<ul style="list-style-type: none"> ◆ The inverter board and current sensor is anti-connected or the current sensor is in incorrect direction. ◆ The inverter board or current sensor is damaged. 					

To be continued

Continued

Failure code Outdoor digital display tube: 119-0, 1 Indoor wired controller77	Indoor unit LED status	LED5		Failure description: The current detection of inverter control board 1 and 2 is abnormal
		20 times		
	Outdoor unit LED status	LED1	LED2	
Normal		Normal		
1. Model	Failure diagnosis and troubleshooting			
Flow Logic III series	Diagnosis		Troubleshooting	
2. Abnormity detection method	<pre> graph TD A{Replace the corresponding control boards on failure unit with inverter control board and module driver board respectively and check if the control board is in abnormal?} -- Y --> B[Replace the abnormal yinverter control board or module driver board.] A -- N --> C{Replace the compressor on the failure unit to drive with compressor in good performance and check if the compressor is abnormal?} C -- Y --> D[Replace the abnormal compressor.] </pre>			
3. Abnormity confirmation conditions				
The current detection sensor of inverter control board is in abnormal conditions, disconnected or connected incorrectly.				
4. Possible causes				
<ul style="list-style-type: none"> ◆ The inverter board and current sensor is anti-connected or the current sensor is in incorrect direction. ◆ The inverter board or current sensor is damaged. 				

Failure code Outdoor digital display tube: 120, 121-0, 1 Indoor wired controller: 78, 79	Indoor unit LED status		LED5		Failure description: Abnormal power supply of the inverter control board 1 and 2
	Outdoor unit LED status		20 times		
			LED1	LED2	
			Normal	Normal	
1. Model	Failure diagnosis and troubleshooting				
Flow Logic III series	Diagnosis		Troubleshooting		
2. Abnormity detection method	<pre> graph TD A{Check if the supply voltage is normal.} -- N --> B[Adjust the power supply.] A -- Y --> C{Check if the electrical cabinet is correctly wired.} C -- N --> D[Reconnect or re-fix it in accordance with circuit diagram.] C -- Y --> E{Check if the PTC or relay is contacted.} E -- N --> F[Adjust or replace PTC or relay.] E -- Y --> G{Check if the voltage between P and N is less than 420V.} G -- N --> H[The DC bus voltage of variable frequency board is abnormal, replace the board.] G -- Y --> I([Check the rectifier bridge, electrolytic capacitor, electric reactor in variable frequency loop.]) </pre>				
3. Abnormity confirmation conditions					
The power supply of inverter control board is interrupted instantly.					
4. Possible causes					
<ul style="list-style-type: none"> ◆ Check if the supply voltage is abnormal. ◆ Check if the PTC or relay contacts or not. ◆ Check if the DC bus voltage is normal. ◆ Check if the DC power supply of inverter board is normal. 	<ul style="list-style-type: none"> ◆ The supply voltage is found with abnormal fluctuations. ◆ The PTC or relay does not contact. ◆ The inverter control board is in poor performance. 				

Failure code Outdoor digital display tube: 122-0, 1 Indoor wired controller: 7A	Indoor unit LED status	LED5		Failure description: The temperature sensors of radiator of inverter control board 1 and 2 are abnormal
		20 times		
	Outdoor unit LED status	LED1	LED2	
		Normal	Normal	
1. Model	Failure diagnosis and troubleshooting			
Flow Logic III series	Diagnosis	Troubleshooting		
2. Abnormity detection method	<pre> graph TD A{Check if the sensor and variable frequency board is connected correctly.} -- N --> B[Adjust the connection between temperature sensor and variable frequency board.] A -- Y --> C{Check if the sensor resistance is normal.} C -- N --> D[Replace the sensor.] C -- Y --> E[Replace the variable frequency board.] </pre>			
3. Abnormity confirmation conditions.				
The temperature sensor is disconnected or the resistance is incorrect.				
4. Possible causes				
<ul style="list-style-type: none"> ◆ The resistance of temperature sensor is found with drift. ◆ The inverter board acquires inaccurate temperature. 				

Failure code Outdoor digital display tube: 125-0, 1 Indoor wired controller: 7D	Indoor unit LED status	LED5		Failure description: The frequency of compressor 1 and 2 don't match
		20 times		
	Outdoor unit LED status	LED1	LED2	
		Normal	Normal	
1. Model	Failure diagnosis and troubleshooting			
Flow Logic III series	Diagnosis		Troubleshooting	
2. Abnormity detection method	<pre> graph TD A{Check if the power module is normal.} -- Y --> B(Replace the neighboring electrical cabinet by exclusion method before handling.) A -- N --> C[Replace the power module or ensure the communication circuit between power module and variable frequency board is secured.] </pre>			
3. Abnormity confirmation conditions				
(current frequency \geq INV target frequency +3Hz) or (target frequency ≥ 0 && actual frequency =0) for continuous 5 minutes				
4. Possible causes				
<ul style="list-style-type: none"> ◆ The power module and inverter board are connected loosely, which results in detection failure of compressor rotation speed. ◆ The power module is damaged. 				

Failure code Outdoor digital display tube: 555.0, 1, 2, 3 Indoor wired controller: /	Indoor unit LED status	LED5		Failure description: Overload standby/heating standby at 26°C/low pressure (lack of refrigerant) standby/cooling standby at 54°C	
	20 times				
	Outdoor unit LED status	LED1	LED2		
		Normal	Normal		
1. Model	Failure diagnosis and troubleshooting				
Flow Logic III series	Diagnosis	Troubleshooting			
2. Abnormity detection method	<pre> graph TD A{Failure 555.0} -- N --> B[Check if the BM1-5 is set at 1 and the capacity of unit is above 130%.] A -- Y --> C{Failure 555.1} C -- N --> D[Check if the BM1-4 is set at 1 and the outdoor ambient temperature reaches 26°C.] C -- Y --> E{Failure 555.2} E -- N --> F[Check the unit for refrigerant leakage and if the values of high/low pressure sensor are correct.] E -- Y --> G{Failure 555.3} G -- N --> H[Check if the environment temperature is above 54°C in cooling.] </pre>				
3. Abnormity confirmation conditions					
Power on is not allowed in following situations: the capacity is above 130% or below 50%; heating when the outdoor ambient temperature is above 26°C upon system standby; start cooling Ps<0.23Mpa or heating Ps<0.12Mpa upon system standby; system standby with temperature above 54°C.					
4. Possible causes					
<ul style="list-style-type: none"> ◆ The dip switch is configured with capacity/ heating with outdoor ambient temperature exceeding 26°C/cooling with the temperature exceeding 54°C; ◆ System air leakage results in too low pressure of units. 					

18. Sensor Resistance Table

No.	Model	Name	Code	Characteristic
1	AW- YDV250HT-H16	Suction temp. sensor (Ts, Ts1, Ts2, Tsco)	MHW551A022	R25=10KΩ±3%, B25/50=3700K±3%
2	AW- YDV280HT-H16	Indoor coil temp. sensor (Tdef1, Tdef2, Toci1, Toci2, Tliqsc)	MHW551A026	R25=10KΩ±3%, B25/50=3700K±3%
3	AW- YDV335HT-H16	Outdoor ambient temp. sensor (Tao)	MHW551A025	R25=10KΩ±3%, B25/50=3700K±3%
4	AW- YDV400HT-H16	Discharging temp. \ oil temp. sensor (Toil1, Toil2, Td1, Td2, Toilp, Tsuc)	MHW551A021	R80=50KΩ±3%, B25/50=4450K±3%
5	AW- YDV450HT-H16	Power module temp. sensor (Tfin)	MHW551A020	R50=17KΩ±2%, B25/50=4170K±3%

R25=10KΩ±3% B25/50=3700K±3%					
Temp (°C)	resistance (KΩ)			% (resist.tol)	
	Rmax	R (t)Normal	Rmin	MAX(+)	MIN(-)
-30	145.82	135.02	124.22	7.00	7.00
-29	138.07	129.13	120.18	6.93	6.93
-28	131.79	123.34	114.89	6.85	6.85
-27	125.67	117.68	109.70	6.78	6.78
-26	119.71	112.18	104.65	6.71	6.71
-25	113.93	106.84	99.75	6.64	6.64
-24	108.36	101.69	95.01	6.56	6.56
-23	103.00	96.72	90.44	6.49	6.49
-22	97.85	91.95	86.05	6.42	6.42
-21	92.92	87.37	81.83	6.35	6.35
-20	88.20	82.99	77.79	6.27	6.27
-19	83.70	78.82	73.93	6.20	6.20
-18	79.42	74.83	70.25	6.13	6.13
-17	75.34	71.04	66.74	6.05	6.05
-16	71.47	67.44	63.40	5.98	5.98
-15	67.80	64.02	60.23	5.91	5.91
-14	64.32	60.77	57.22	5.84	5.84
-13	61.02	57.69	54.37	5.76	5.76
-12	57.90	54.78	51.66	5.69	5.69
-11	54.94	52.02	49.10	5.62	5.62
-10	52.15	49.41	46.67	5.55	5.55
-9	49.51	46.94	44.37	5.47	5.47
-8	47.02	44.61	42.20	5.40	5.40
-7	44.66	42.40	40.14	5.33	5.33
-6	42.43	40.32	38.20	5.25	5.25
-5	40.33	38.35	36.36	5.18	5.18
-4	38.35	36.48	34.62	5.11	5.11
-3	36.47	34.72	32.97	5.04	5.04
-2	34.70	33.06	31.42	4.96	4.96
-1	33.03	31.49	29.95	4.89	4.89
0	31.45	30.00	28.56	4.82	4.82
1	29.95	28.59	27.24	4.75	4.75
2	28.54	27.26	25.99	4.67	4.67
3	27.20	26.01	24.81	4.60	4.60
4	25.94	24.82	23.69	4.53	4.53
5	24.74	23.69	22.63	4.45	4.45
6	23.61	22.62	21.63	4.38	4.38
7	22.54	21.61	20.68	4.31	4.31
8	21.52	20.65	19.77	4.24	4.24
9	20.56	19.74	18.92	4.16	4.16
10	19.65	18.87	18.10	4.09	4.09
11	18.78	18.05	17.33	4.02	4.02
12	17.96	17.28	16.59	3.95	3.95
13	17.18	16.54	15.90	3.87	3.87
14	16.44	15.83	15.23	3.80	3.80
15	15.73	15.17	14.60	3.73	3.73
16	15.06	14.53	14.00	3.65	3.65
17	14.42	13.93	13.43	3.58	3.58
18	13.82	13.35	12.88	3.51	3.51

R25=10KΩ±3% B25/50=3700K±3%					
Temp	resistance (KΩ)			% (resist.tol)	
(°C)	Rmax	R (t)Normal	Rmin	MAX(+)	MIN(-)
19	13.24	12.80	12.36	3.44	3.44
20	12.69	12.28	11.86	3.36	3.36
21	12.17	11.78	11.39	3.29	3.29
22	11.67	11.30	10.94	3.22	3.22
23	11.19	10.85	10.51	3.15	3.15
24	10.73	10.41	10.09	3.07	3.07
25	10.30	10.00	9.70	3.00	3.00
26	9.90	9.60	9.31	3.06	3.06
27	9.51	9.23	8.94	3.13	3.13
28	9.15	8.86	8.58	3.19	3.19
29	8.80	8.52	8.24	3.25	3.25
30	8.46	8.19	7.92	3.31	3.31
31	8.14	7.87	7.61	3.38	3.38
32	7.83	7.57	7.31	3.44	3.44
33	7.53	7.28	7.02	3.50	3.50
34	7.25	7.00	6.75	3.56	3.56
35	6.98	6.73	6.49	3.63	3.63
36	6.72	6.48	6.24	3.69	3.69
37	6.47	6.23	6.00	3.75	3.75
38	6.23	6.00	5.77	3.81	3.81
39	6.00	5.77	5.55	3.88	3.88
40	5.78	5.56	5.34	3.94	3.94
41	5.56	5.35	5.14	4.00	4.00
42	5.36	5.15	4.94	4.06	4.06
43	5.17	4.96	4.76	4.13	4.13
44	4.98	4.78	4.58	4.19	4.19
45	4.80	4.60	4.41	4.25	4.25
46	4.63	4.43	4.24	4.31	4.31
47	4.46	4.27	4.09	4.38	4.38
48	4.30	4.12	3.94	4.44	4.44
49	4.15	3.97	3.79	4.50	4.50
50	4.00	3.83	3.65	4.56	4.56
51	3.86	3.69	3.52	4.63	4.63
52	3.72	3.56	3.39	4.69	4.69
53	3.59	3.43	3.27	4.75	4.75
54	3.47	3.31	3.15	4.81	4.81
55	3.35	3.19	3.04	4.88	4.88
56	3.23	3.08	2.93	4.94	4.94
57	3.12	2.97	2.83	5.00	5.00
58	3.02	2.87	2.73	5.06	5.06
59	2.91	2.77	2.63	5.13	5.13
60	2.82	2.68	2.54	5.19	5.19
61	2.72	2.59	2.45	5.25	5.25
62	2.63	2.50	2.36	5.31	5.31
63	2.54	2.41	2.28	5.38	5.38
64	2.46	2.33	2.21	5.44	5.44
65	2.38	2.26	2.13	5.50	5.50
66	2.30	2.18	2.06	5.56	5.56

R25=10KΩ±3% B25/50=3700K±3%					
Temp (°C)	resistance (KΩ)			% (resist.tol)	
	Rmax	R (t)Normal	Rmin	MAX(+)	MIN(-)
67	2.23	2.11	1.99	5.63	5.63
68	2.16	2.04	1.92	5.69	5.69
69	2.09	1.97	1.86	5.75	5.75
70	2.02	1.91	1.80	5.81	5.81
71	1.96	1.85	1.74	5.88	5.88
72	1.90	1.79	1.69	5.94	5.94
73	1.84	1.74	1.63	6.00	6.00
74	1.78	1.68	1.58	6.06	6.06
75	1.73	1.63	1.53	6.13	6.13
76	1.68	1.58	1.48	6.19	6.19
77	1.63	1.53	1.43	6.25	6.25
78	1.58	1.48	1.39	6.31	6.31
79	1.53	1.44	1.35	6.38	6.38
80	1.49	1.40	1.31	6.44	6.44
81	1.44	1.36	1.27	6.50	6.50
82	1.40	1.32	1.23	6.56	6.56
83	1.36	1.28	1.19	6.63	6.63
84	1.32	1.24	1.16	6.69	6.69
85	1.29	1.20	1.12	6.75	6.75
86	1.25	1.17	1.09	6.81	6.81
87	1.21	1.14	1.06	6.88	6.88
88	1.18	1.10	1.03	6.94	6.94
89	1.15	1.07	1.00	7.00	7.00
90	1.12	1.04	0.97	7.06	7.06
91	1.09	1.01	0.94	7.13	7.13
92	1.06	0.99	0.91	7.19	7.19
93	1.03	0.96	0.89	7.25	7.25
94	1.00	0.93	0.86	7.31	7.31
95	0.97	0.90	0.84	7.38	7.38
96	0.94	0.88	0.81	7.44	7.44
97	0.92	0.85	0.79	7.50	7.50
98	0.89	0.83	0.77	7.56	7.56
99	0.87	0.81	0.75	7.63	7.63
100	0.84	0.78	0.72	7.69	7.69
101	0.82	0.76	0.70	7.75	7.75
102	0.80	0.74	0.68	7.81	7.81
103	0.77	0.72	0.66	7.88	7.88
104	0.75	0.69	0.64	7.94	7.94
105	0.73	0.67	0.62	8.00	8.00

R80=50KΩ±3% B25/80=4450K±3%					
Temp (°C)	resistance (KΩ)			% (resist.tol)	
	Rmax	R (t)Normal	Rmin	MAX(+)	MIN(-)
0	1749.01	1921.99	2094.97	9.00	9.00
1	1651.43	1813.27	1975.10	8.93	8.93
2	1560.17	1711.65	1863.13	8.85	8.85
3	1474.74	1616.59	1758.45	8.78	8.78
4	1394.71	1527.61	1660.51	8.70	8.70
5	1319.68	1444.25	1568.82	8.63	8.63
6	1249.30	1366.10	1482.90	8.55	8.55
7	1183.21	1292.77	1402.34	8.48	8.48
8	1121.12	1223.94	1326.75	8.40	8.40
9	1062.76	1159.27	1255.77	8.33	8.33
10	1007.85	1098.47	1189.10	8.25	8.25
11	956.17	1041.29	1126.42	8.18	8.18
12	907.49	987.48	1067.46	8.10	8.10
13	861.62	936.80	1011.98	8.03	8.03
14	818.37	889.05	959.73	7.95	7.95
15	777.57	844.04	910.51	7.88	7.88
16	739.07	801.59	864.11	7.80	7.80
17	702.71	761.53	820.36	7.73	7.73
18	668.35	723.72	779.08	7.65	7.65
19	635.89	688.00	740.12	7.58	7.58
20	605.19	654.25	703.32	7.50	7.50
21	576.15	622.36	668.57	7.43	7.43
22	548.66	592.19	635.72	7.35	7.35
23	522.65	563.65	604.66	7.28	7.28
24	498.01	536.64	575.28	7.20	7.20
25	474.66	511.08	547.49	7.13	7.13
26	452.54	486.86	521.19	7.05	7.05
27	431.56	463.92	496.28	6.98	6.98
28	411.67	442.18	472.69	6.90	6.90
29	392.80	421.57	450.34	6.83	6.83
30	374.89	402.03	429.17	6.75	6.75
31	357.89	383.49	409.09	6.68	6.68
32	341.75	365.90	390.05	6.60	6.60
33	326.42	349.20	371.99	6.53	6.53
34	311.85	333.35	354.85	6.45	6.45
35	298.00	318.30	338.59	6.38	6.38
36	284.84	304.00	323.15	6.30	6.30
37	272.33	290.41	308.49	6.23	6.23
38	260.43	277.49	294.56	6.15	6.15
39	249.10	265.22	281.33	6.08	6.08
40	238.33	253.54	268.75	6.00	6.00
41	228.07	242.44	256.80	5.93	5.93
42	218.31	231.87	245.44	5.85	5.85
43	209.01	221.82	234.63	5.78	5.78
44	200.15	212.25	224.35	5.70	5.70
45	191.72	203.14	214.57	5.63	5.63
46	183.67	194.47	205.26	5.55	5.55
47	176.01	186.20	196.40	5.48	5.48

R80=50KΩ±3% B25/80=4450K±3%					
Temp (°C)	resistance (KΩ)			% (resist.tol)	
	Rmax	R (t)Normal	Rmin	MAX(+)	MIN(-)
48	168.70	178.33	187.96	5.40	5.40
49	161.74	170.83	179.93	5.33	5.33
50	155.09	163.68	172.28	5.25	5.25
51	148.75	156.87	164.98	5.18	5.18
52	142.70	150.37	158.04	5.10	5.10
53	136.92	144.17	151.41	5.03	5.03
54	131.41	138.26	145.10	4.95	4.95
55	126.15	132.61	139.08	4.88	4.88
56	121.12	127.23	133.34	4.80	4.80
57	116.32	122.09	127.86	4.73	4.73
58	111.73	117.18	122.63	4.65	4.65
59	107.35	112.49	117.64	4.58	4.58
60	103.16	108.02	112.88	4.50	4.50
61	99.15	103.74	108.33	4.43	4.43
62	95.32	99.65	103.99	4.35	4.35
63	91.66	95.75	99.84	4.28	4.28
64	88.15	92.01	95.88	4.20	4.20
65	84.80	88.44	92.09	4.13	4.13
66	81.58	85.03	88.47	4.05	4.05
67	78.51	81.76	85.01	3.98	3.98
68	75.57	78.64	81.70	3.90	3.90
69	72.75	75.65	78.54	3.83	3.83
70	70.05	72.78	75.51	3.75	3.75
71	67.47	70.04	72.61	3.68	3.68
72	64.99	67.42	69.84	3.60	3.60
73	62.61	64.90	67.19	3.53	3.53
74	60.34	62.49	64.65	3.45	3.45
75	58.15	60.19	62.22	3.38	3.38
76	56.06	57.97	59.89	3.30	3.30
77	54.05	55.85	57.65	3.23	3.23
78	52.13	53.82	55.52	3.15	3.15
79	50.28	51.87	53.47	3.08	3.08
80	48.50	50.00	51.50	3.00	3.00
81	46.73	48.21	49.68	3.07	3.07
82	45.03	46.48	47.94	3.13	3.13
83	43.40	44.83	46.27	3.20	3.20
84	41.83	43.25	44.66	3.27	3.27
85	40.33	41.72	43.11	3.33	3.33
86	38.89	40.26	41.63	3.40	3.40
87	37.51	38.86	40.20	3.47	3.47
88	36.18	37.51	38.83	3.53	3.53
89	34.91	36.21	37.51	3.60	3.60
90	33.68	34.96	36.24	3.67	3.67
91	32.50	33.76	35.03	3.73	3.73
92	31.37	32.61	33.85	3.80	3.80
93	30.29	31.50	32.72	3.87	3.87
94	29.24	30.44	31.64	3.93	3.93

R80=50KΩ±3% B25/80=4450K±3%					
Temp (°C)	resistance (KΩ)			% (resist.tol)	
	Rmax	R (t)Normal	Rmin	MAX(+)	MIN(-)
95	28.24	29.41	30.59	4.00	4.00
96	27.27	28.43	29.58	4.07	4.07
97	26.34	27.48	28.61	4.13	4.13
98	25.45	26.56	27.68	4.20	4.20
99	24.59	25.69	26.78	4.27	4.27
100	23.76	24.84	25.91	4.33	4.33
101	22.97	24.02	25.08	4.40	4.40
102	22.20	23.24	24.28	4.47	4.47
103	21.46	22.48	23.50	4.53	4.53
104	20.75	21.75	22.75	4.60	4.60
105	20.07	21.05	22.03	4.67	4.67
106	19.41	20.37	21.34	4.73	4.73
107	18.77	19.72	20.67	4.80	4.80
108	18.16	19.09	20.02	4.87	4.87
109	17.57	18.49	19.40	4.93	4.93
110	17.01	17.90	18.80	5.00	5.00
111	16.46	17.34	18.22	5.07	5.07
112	15.93	16.79	17.66	5.13	5.13
113	15.42	16.27	17.11	5.20	5.20
114	14.93	15.76	16.59	5.27	5.27
115	14.46	15.28	16.09	5.33	5.33
116	14.01	14.80	15.60	5.40	5.40
117	13.57	14.35	15.13	5.47	5.47
118	13.14	13.91	14.68	5.53	5.53
119	12.73	13.49	14.24	5.60	5.60
120	12.34	13.08	13.82	5.67	5.67
121	11.96	12.69	13.41	5.73	5.73
122	11.59	12.31	13.02	5.80	5.80
123	11.24	11.94	12.64	5.87	5.87
124	10.90	11.58	12.27	5.93	5.93
125	10.57	11.24	11.92	6.00	6.00
126	10.25	10.91	11.57	6.07	6.07
127	9.94	10.59	11.24	6.13	6.13
128	9.65	10.29	10.92	6.20	6.20
129	9.36	9.99	10.61	6.27	6.27
130	9.09	9.70	10.32	6.33	6.33
131	8.82	9.43	10.03	6.40	6.40
132	8.57	9.16	9.75	6.47	6.47
133	8.32	8.90	9.48	6.53	6.53
134	8.08	8.65	9.22	6.60	6.60
135	7.85	8.41	8.97	6.67	6.67
136	7.63	8.18	8.73	6.73	6.73
137	7.42	7.96	8.50	6.80	6.80
138	7.21	7.74	8.27	6.87	6.87
139	7.01	7.53	8.06	6.93	6.93
140	6.82	7.33	7.85	7.00	7.00

R50=17KQ±2% B25/50=4170K±3%							
Temp (°C)	Rmin	R (t)Normal	Rmax	Temp (°C)	Rmin	R (t)Normal	Rmax
0	164.73	176.38	187.00	53.00	14.73	15.07	15.41
1	156.21	167.10	177.02	54.00	14.14	14.48	14.82
2	148.19	158.36	167.64	55.00	13.58	13.93	14.26
3	140.63	150.13	158.81	56.00	13.05	13.39	13.72
4	133.50	142.38	150.49	57.00	12.53	12.88	13.20
5	126.77	135.07	142.66	58.00	12.04	12.38	12.71
6	120.42	128.18	135.28	59.00	11.58	11.91	12.24
7	114.43	121.68	128.32	60.00	11.13	11.46	11.79
8	108.77	115.55	121.76	61.00	10.70	11.03	11.35
9	103.42	109.76	115.58	62.00	10.29	10.62	10.94
10	98.37	104.30	109.74	63.00	9.90	10.23	10.54
11	93.59	99.14	104.23	64.00	9.52	9.85	10.16
12	89.07	94.26	99.02	65.00	9.16	9.49	9.79
13	84.80	89.65	94.11	66.00	8.82	9.14	9.44
14	80.76	85.29	89.47	67.00	8.49	8.81	9.10
15	76.93	81.17	85.08	68.00	8.18	8.49	8.78
16	73.31	77.27	80.93	69.00	7.87	8.18	8.47
17	69.87	73.58	77.01	70.00	7.58	7.89	8.17
18	66.62	70.09	73.30	71.00	7.31	7.61	7.89
19	63.54	66.78	69.78	72.00	7.04	7.33	7.61
20	60.62	63.65	66.46	73.00	6.78	7.08	7.35
21	57.84	60.68	63.31	74.00	6.54	6.83	7.10
22	55.22	57.87	60.33	75.00	6.30	6.59	6.85
23	52.72	55.20	57.50	76.00	6.08	6.36	6.62
24	50.35	52.67	54.82	77.00	5.86	6.14	6.39
25	48.10	50.27	52.28	78.00	5.65	5.93	6.18
26	45.97	47.99	49.87	79.00	5.45	5.72	5.97
27	43.94	45.83	47.59	80.00	5.26	5.53	5.77
28	42.01	43.77	45.42	81.00	5.08	5.34	5.58
29	40.18	41.82	43.37	82.00	4.90	5.16	5.39
30	38.43	39.97	41.41	83.00	4.73	4.98	5.22
31	36.78	38.21	39.56	84.00	4.57	4.82	5.04
32	35.20	36.53	37.79	85.00	4.41	4.66	4.88
33	33.70	34.94	36.12	86.00	4.26	4.50	4.72
34	32.27	33.43	34.53	87.00	4.12	4.35	4.57
35	30.91	31.99	33.01	88.00	3.98	4.21	4.42
36	29.61	30.62	31.57	89.00	3.84	4.07	4.28
37	28.38	29.31	30.21	90.00	3.71	3.94	4.14
38	27.20	28.07	28.90	91.00	3.59	3.81	4.01
39	26.08	26.89	27.66	92.00	3.47	3.69	3.88
40	25.01	25.76	26.48	93.00	3.36	3.57	3.76
41	23.99	24.69	25.36	94.00	3.24	3.45	3.64
42	23.01	23.66	24.29	95.00	3.14	3.34	3.53
43	22.09	22.69	23.27	96.00	3.04	3.24	3.42
44	21.20	21.76	22.30	97.00	2.94	3.14	3.32
45	20.35	20.87	21.37	98.00	2.84	3.04	3.21
46	19.55	20.02	20.49	99.00	2.75	2.94	3.12
47	18.78	19.21	19.64	100.00	2.66	2.85	3.02
48	18.04	18.44	18.84	101.00	2.58	2.76	2.93
49	17.33	17.70	18.07	102.00	2.50	2.68	2.84
50	16.66	17.00	17.34	103.00	2.42	2.60	2.76
51	15.99	16.33	16.67	104.00	2.34	2.52	2.68
52	15.34	15.68	16.02	105.00	2.27	2.44	2.60

19. Fan Motor Installation and Detection Standard

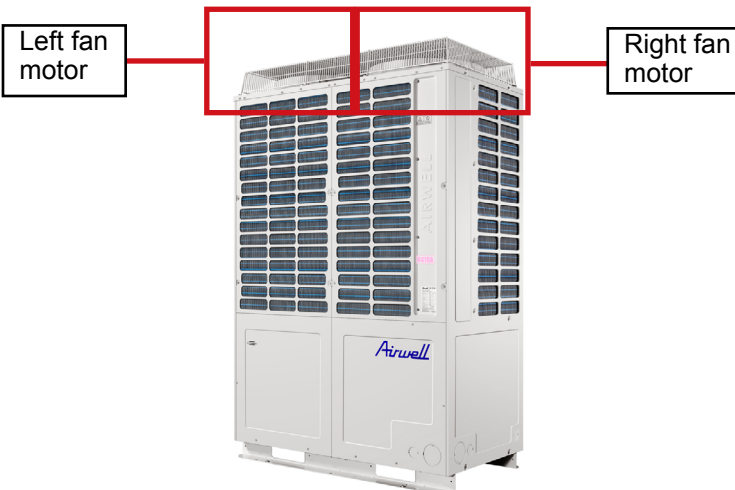
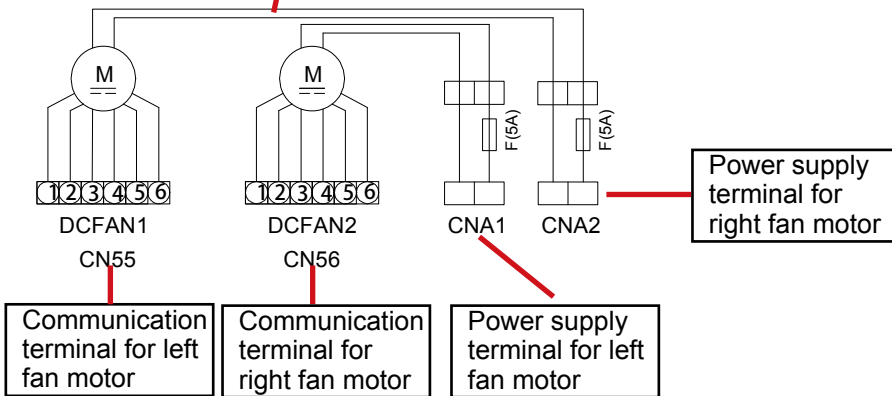
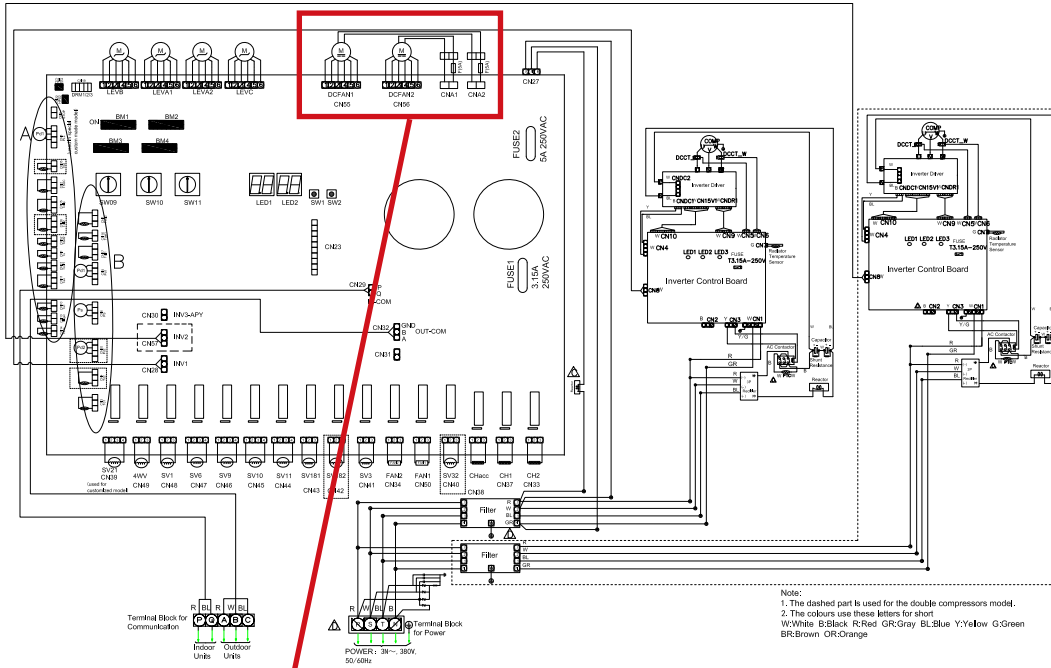

Note:

1. There is no effect when the power supply terminal positions of the left and right motors are interchanged.
2. If the communication terminal positions of the left and right motors are interchanged, the unit can still operate normally, but it will cause the failure code inconsistent. For example, 73-0 failure code definition: Fan 1 over current (Left), in this case, the right fan needs to be checked.
3. Please plug and unplug the motor terminal when the PCB is powered off.

Fan motor code: MHW512T001

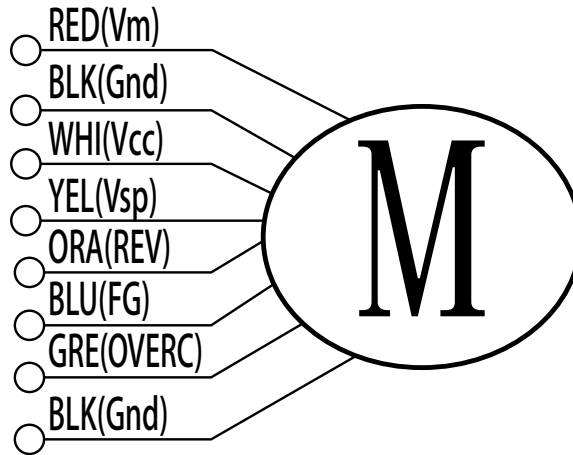

Expected readings of control PWB VDC outputs to DCFM			Expected readings of DC fan motor circuit board resistances		
Multi meter test points for VDC			Multi meter test points for Ω		
Multimeter red probe	Multimeter black probe	PCB DC volts	Multimeter black probe	Multimeter red probe	DCFm PWB resistance value
Vcc	GND	Vcc=13.5 ~ 16.5 VDC	Vcc	GND	8K
REV	GND	/	REV	GND	∞
Vsp	GND	0 ~ 6.5V	Vsp	GND	200K
FG	GND	High level: $\geq V_{cc} - 0.7V_{DC}$; Low level: $\leq 0.7V_{DC}$	FG	GND	∞
OVERC	GND	/	OVERC	GND	∞

Wiring of DC fan motor

1	Vcc	15VDC	White
2	REV	Reverse signal output	Orange
3	Vsp	Speed control voltage	Yellow
4	FG	Speed signal output	Blue
5	OVERC	Overcurrent signal detection	Green
6	GND	DC loop ground	Black



Expected readings of control PWB VDC outputs to DCFM			Expected readings of DC fan motor circuit board resistances		
Multi meter test points for VDC			Multi meter test points for Ω		
Multimeter red probe	Multimeter black probe	PCB DC volts	Multimeter black probe	Multimeter red probe	DCFm PWB resistance value
Vm	GND	310V	Vm	GND	∞

Wiring of DC fan motor

1	Vm	310VDC(+)	Red
2	GND	310VDC(-)	Black

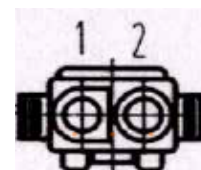

Airwell

CLIMATISATION ET CHAUFFAGE

WARNING :

The design and specifications are subject to change without prior notice for product improvement. Consult with the sales agency or manufacturer for details.

ATTENTION :

Le design et les données techniques sont donnés à titre indicatif et peuvent être modifiés sans préavis.



AIRWELL RESIDENTIAL SAS

10,Rue du Fort de Saint Cyr,
78180 Montigny le Bretonneux- France
www.airwell-res.com