

# Central Controller Operation & Installation Manual

RWV06

## CONTENT

Function introduction of central controller.....	1
Part info for central controller .....	2
Page & Key Explanation.....	4
Address Setting When Using Central Controller .....	6
Function Operation .....	20
Installation .....	42

No. 0150532461

- Please read this operation manual before using the air conditioner.
- Please keep this manual carefully and safely.

# Function introduction of central controller

---

1. RWV06 can control VRF and SuperMatch (including single split and multi split). 256 indoor units can be controlled when used with VRF and 128 indoor units when with single split & supermatch.

① When controlling VRF, RWV06 should be used together with converter.

One converter is connected with one system of VRF firstly and then all converters are hand in hand connected to RWV06.

How to choose VRF: System Settings-Local-Type Select-VRF.

② When RWV06 controls the SuperMatch series, each indoor unit requires one YCJ-A002 as the adapter. The YCJ-A002 adapters are connected with RWV06 hand in hand.

How to choose multi: System settings — Local – Type Select– Single.

2. Main functions of central controller

① Monitoring and controlling indoor running state such as ON/OFF, Mode, Fan, Set temp. and error code.

② Zone setting, editing and deleting.

③ Realizing ON/OFF, mode, fan, temperature setting for single/zone/all indoor unit(s).

④ Checking indoor unit detailed information such as real temperature, coil temperature, error code.

⑤ For VRF, three kinds of controlling mode: LIFO, Central & Force can be selected for indoor units; while only Force & LIFO mode can be selected for single split unit.

LIFO: the indoor unit will execute the last order send by central controller, wired controller or remote controller. For example, if firstly sending low speed fan order by central controller and then sending high speed fan order by wired controller, the indoor unit will execute high fan.

Central: central controller enjoys all functions while wired & remote controller can only control ON/OFF of indoor units.

Force: central controller enjoys all functions while wired & remote controller cannot control indoor units.

⑥ Receiving outer signal input: when receiving outer fire alarm signal, central controller will turn all indoor units off.

⑦ Weekly timer setting. Weekly timer for one or some or all units can be set and can run in cycle.

# Part info for central controller

---

## ON/OFF key:

Press the ON/OFF key for 2-3 seconds to turn on the controller after powering on. Keep pressing the ON/OFF key for 5 seconds to turn off.

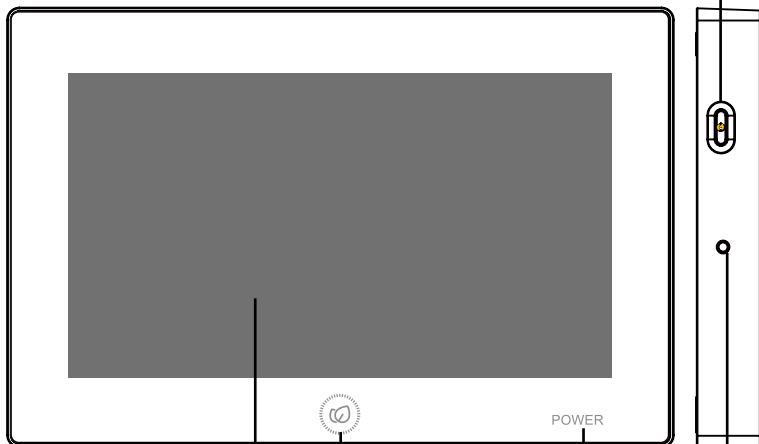

## Display/touch screen:

Display and operation area.

## Screensaver key:

Press to turn off screen light and press again to turn on.

## Power light:

Power light will be on after powering on.

## Reset key:

Press to reboot central controller.

# Part info for central controller

---

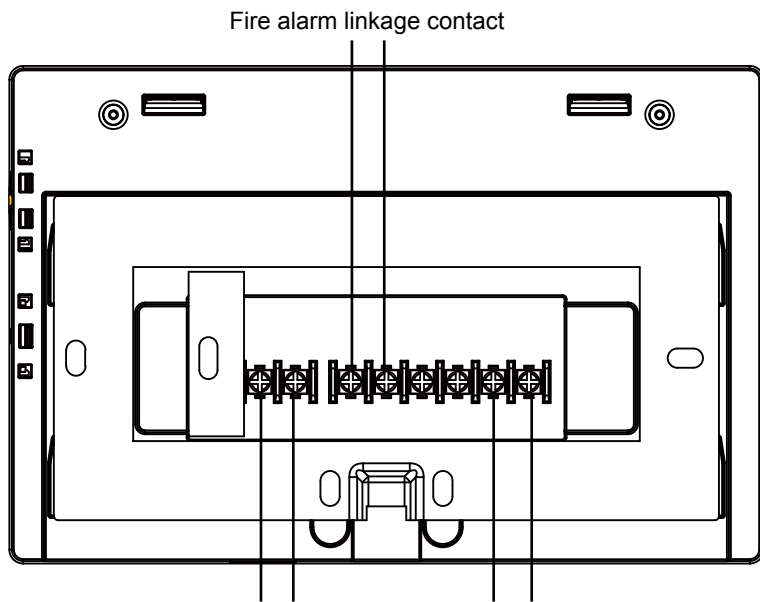

Power: 12V DC, there is +- for power      Communication port for connecting converter

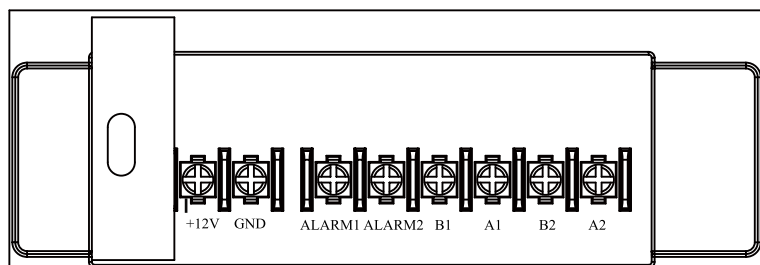

Power (12V, GND): 12V DC, please pay attention to +-of power.

Fire alarm linkage contact (ALARM1, ALARM2): AC works normally when closed and all AC turned off when open circuit.



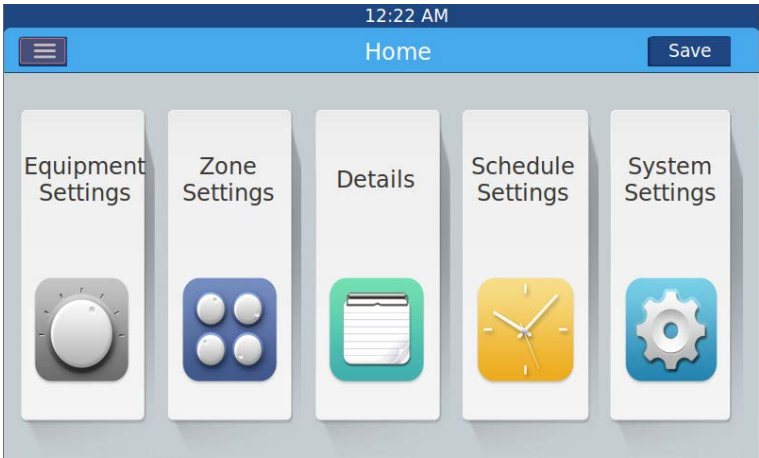

Third party interface (B1, A1): A1 should be connected to 485+ while B1 485-.

Communication port (B2, A2): It is used for connecting converter, please pay attention to +-. A2 should be connected to 485+ while B2 485-.

# Page & Key Explanation



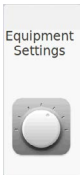

After turning on central controller, home page will show as above and detailed menu is as following:

Menu/icon	Function
<p>AC detailed menu</p> 	<p>POP will show after click the icon:</p> <ul style="list-style-type: none"> <li> Online AC qty: indicating indoor unit quantity in good communication.</li> <li> Offline AC qty: indicating indoor unit quantity in good communication previously and then in bad communicaiton</li> <li> AC qty set in timer: indicating AC quantity set timer function</li> <li> Error AC qty: indicating AC quantity in malfunction.</li> </ul>
<p>Equipment Settings</p> 	<p>Press to enter equipment setting interface and do settings as follows:</p> <p>Display all AC list and condition information. Turning page for more information</p> <p>AC mode can be checked and adjusted according to check area. And application range can be selected and it can realize All on/All off function.</p>

# Page & Key Explanation

---

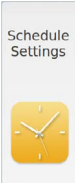
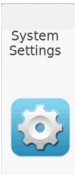
Menu/icon	Function
 <p>Zone Settings</p>	<p>Press to enter Zone Settings interface and do settings as follows: Add/delete group, choose AC, edit group name.</p>
 <p>Details</p>	<p>Click to enter details interface, in which, the following information can be seen: AC condition/mode condition, error code, running time &amp; parameters.</p>
 <p>Schedule Settings</p>	<p>Click to enter schedule settings interface, the following setting can be operated: After entering, it will display all schedule settings lists. One or multi days in a week can be chosen for timing setting. Timer on/off, temperature, mode, fan, temperature range(16-30°C), etc.</p>
 <p>System Settings</p>	<p>Click to enter the interface, and the following setting can be operated: it includes Local Settings, Energy Saving, Password and Help.</p>

# Address Setting When Using Central Controller

When applying central controller, it is required to set address by dip switch for easy checking and maintenance.

## When controlling VRF

System structure chart when controlling VRF:

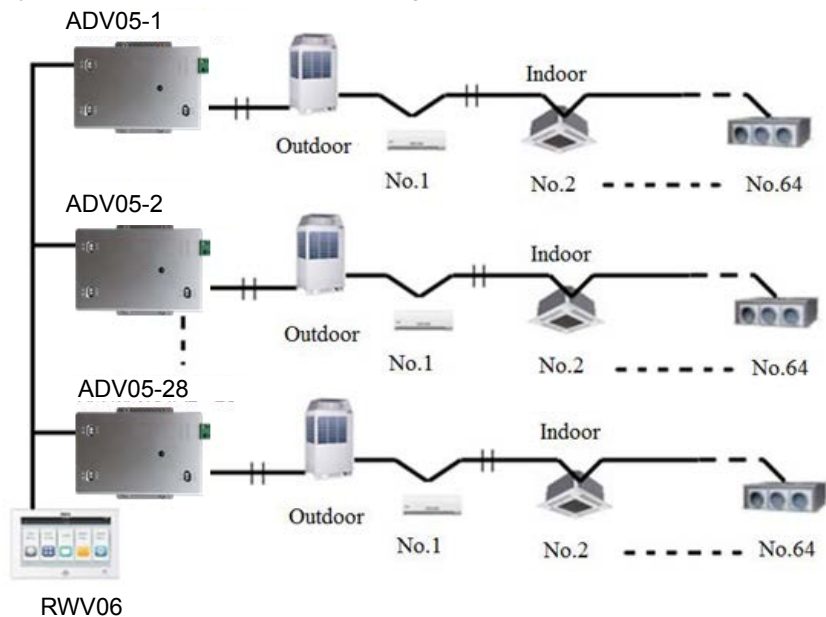

# Address Setting When Using Central Controller

For every system of AC, address starts from No. 1 to last indoor unit of the system. If totally 20 indoor units are connected in one system, address should be 1-20; if 50 in one system, address should be 1-50; the biggest address is 64.

Note: every indoor address starts from 1.

## 1. Indoor address setting

The address used in central control or energy system								
SW03								Central address
(1)	(2)	(3)	(4)	(5)	(6)	(7)	(8)	
1	0	0	0	0	0	0	0	Central address=1
1	0	0	0	0	0	0	1	Central address=2
1	0	0	0	0	0	1	0	Central address=3
1	0	0	0	0	0	1	1	Central address=4
1	0	0	0	0	1	0	0	Central address=5
1	0	0	0	0	1	0	1	Central address=6
1	0	0	0	0	1	1	0	Central address=7
1	0	0	0	0	1	1	1	Central address=8
1	0	0	0	1	0	0	0	Central address=9
1	0	0	0	1	0	0	1	Central address=10
1	0	0	0	1	0	1	0	Central address=11
1	0	0	0	1	0	1	1	Central address=12
1	0	0	0	1	1	0	0	Central address=13
1	0	0	0	1	1	0	1	Central address=14
1	0	0	0	1	1	1	0	Central address=15
1	0	0	0	1	1	1	1	Central address=16
1	0	0	1	0	0	0	0	Central address=17
1	0	0	1	0	0	0	1	Central address=18
1	0	0	1	0	0	1	0	Central address=19
1	0	0	1	0	0	1	1	Central address=20
1	0	0	1	0	1	0	0	Central address=21
1	0	0	1	0	1	0	1	Central address=22



# Address Setting When Using Central Controller

The address used in central control or energy system								
SW03								Central address
(1)	(2)	(3)	(4)	(5)	(6)	(7)	(8)	
1	0	0	1	0	1	1	0	Central address=23
1	0	0	1	0	1	1	1	Central address=24
1	0	0	1	1	0	0	0	Central address=25
1	0	0	1	1	0	0	1	Central address=26
1	0	0	1	1	0	1	0	Central address=27
1	0	0	1	1	0	1	1	Central address=28
1	0	0	1	1	1	0	0	Central address=29
1	0	0	1	1	1	0	1	Central address=30
1	0	0	1	1	1	1	0	Central address=31
1	0	0	1	1	1	1	1	Central address=32
1	0	1	0	0	0	0	0	Central address=33
1	0	1	0	0	0	0	1	Central address=34
1	0	1	0	0	0	1	0	Central address=35
1	0	1	0	0	0	1	1	Central address=36
1	0	1	0	0	1	0	0	Central address=37
1	0	1	0	0	1	0	1	Central address=38
1	0	1	0	0	1	1	0	Central address=39
1	0	1	0	0	1	1	1	Central address=40
1	0	1	0	1	0	0	0	Central address=41
1	0	1	0	1	0	0	1	Central address=42
1	0	1	0	1	0	1	0	Central address=43
1	0	1	0	1	0	1	1	Central address=44
1	0	1	0	1	1	0	0	Central address=45
1	0	1	0	1	1	0	1	Central address=46
1	0	1	0	1	1	1	0	Central address=47
1	0	1	0	1	1	1	1	Central address=48
1	0	1	1	0	0	0	0	Central address=49
1	0	1	1	0	0	0	1	Central address=50

# Address Setting When Using Central Controller

The address used in central control or energy system									
SW03								Central address	
(1)	(2)	(3)	(4)	(5)	(6)	(7)	(8)		
1	0	1	1	0	0	1	0	Central address=51	
1	0	1	1	0	0	1	1	Central address=52	
1	0	1	1	0	1	0	0	Central address=53	
1	0	1	1	0	1	0	1	Central address=54	
1	0	1	1	0	1	1	0	Central address=55	
1	0	1	1	0	1	1	1	Central address=56	
1	0	1	1	1	0	0	0	Central address=57	
1	0	1	1	1	0	0	1	Central address=58	
1	0	1	1	1	0	1	0	Central address=59	
1	0	1	1	1	0	1	1	Central address=60	
1	0	1	1	1	1	0	0	Central address=61	
1	0	1	1	1	1	0	1	Central address=62	
1	0	1	1	1	1	1	0	Central address=63	
1	0	1	1	1	1	1	1	Central address=64	
	0		No need to add 64 to central address					Stay as 0	
	1		Add 64 to central address						
0			Central address set by wired controller is available						
1			Central address set by wired controller is unavailable					Stay as 1	

# Address Setting When Using Central Controller

## 2. Converter address setting

(If the converter is IGU05, sw1 and sw2 can be neglected)

1	2	3	4	5	6	7	8	Converter address
0	1	0	0	0	0	0	0	1
0	1	0	0	0	0	0	1	2
0	1	0	0	0	0	1	0	3
0	1	0	0	0	0	1	1	4
0	1	0	0	0	1	0	0	5
0	1	0	0	0	1	0	1	6
0	1	0	0	0	1	1	0	7
0	1	0	0	0	1	1	1	8
0	1	0	0	1	0	0	0	9
0	1	0	0	1	0	0	1	10
0	1	0	0	1	0	1	0	11
0	1	0	0	1	0	1	1	12
0	1	0	0	1	1	0	0	13
0	1	0	0	1	1	0	1	14
0	1	0	0	1	1	1	0	15
0	1	0	0	1	1	1	1	16
0	1	0	1	0	0	0	0	17
0	1	0	1	0	0	0	1	18
0	1	0	1	0	0	1	0	19
0	1	0	1	0	0	1	1	20
0	1	0	1	0	1	0	0	21
0	1	0	1	0	1	0	1	22
0	1	0	1	0	1	1	0	23
0	1	0	1	0	1	1	1	24
0	1	0	1	1	0	0	0	25
0	1	0	1	1	0	0	1	26
0	1	0	1	1	0	1	0	27

# Address Setting When Using Central Controller

1	2	3	4	5	6	7	8	Converter address
0	1	0	1	1	0	1	1	28
0	1	0	1	1	1	0	0	29
0	1	0	1	1	1	0	1	30
0	1	0	1	1	1	1	0	31
0	1	0	1	1	1	1	1	32

If one indoor unit is connected to converter addressed as No. 1, and its central address is No. 6, the indoor code displayed on central controller is 1-6; if one indoor unit is connected to converter addressed as No. 5, and its central address is No. 20, the indoor code displayed on central controller is 5-20.

Note: when controlling VRF, the RWV06 can control max. 32 converter and max. 256 indoor units. If converter is more than 32 while indoor quantity is less than 256, another RWV06 is needed because converter exceeds 32; If converter is less than 32 while indoor quantity is more than 256, another RWV06 is needed because indoor quantity exceeds 256.

When choose VRF in System settings,HRV can be controlled, 485 terminal of HRV together with converter are hand in hand connected to RWV06, SW903\_2,3 is used to set address, 00~11 stands for indoor unit 1~4, total amount of HRV and VRF indoor units cannot exceed 256.

Please check HRV setting for wire connection and cautions. Functions such as ON/OFF and single unit control can be realized, but zoning and schedule setting are not available (HRV is reserved).

### 3. Third party interface

Communication parameter:

Slave ID is converter's address	
Function code: inquiry 03H; control 10H	
Communication parameter	Point type
Baud rate: 9600	DI: switching value input signal
data bits: 8	DO: switching value output signal
Check bit: None	AI: analog quantity input signal
Stop bit: 1	AO: analog quantity output signal
Start bit: 1, One frame command finished, using CRC to check	

# Address Setting When Using Central Controller

Point table:

Point description	Protocol address	Extra address	Point type	State
All On/All Off	40006		AO (Write)	1: All On 0: All Off
Indoor unit (1-64) ON/OFF setting	40011-40014	0-15	DO (Write)	1: ON 0: OFF
Indoor unit (1-64) ON/OFF state	40015-40018	0-15	DI (Read)	1: ON 0: OFF
Indoor unit (1-64) Malfunction state	40019-40022	0-15	DI (Read)	1: Error 0: Normal
Indoor unit 1 ON/OFF setting	40031		AO (Write)	1: ON, 0: OFF
Indoor unit 1 mode setting	40032			0: Auto, 1: Fan 2: Cooling, 3: Dry 4: Heating
Indoor unit 1 temperature setting	40033			Integer from 16 to 30 Integer from 16 to 30
Indoor unit 1 fan speed setting	40034			0: Auto, 1: Low 2: Medium, 3: High
Indoor unit 1 ON/OFF state	40035		AI (Read)	1: ON, 0: OFF
Indoor unit 1 mode	40036			0: Auto, 1: Fan 2: Cooling, 3: Dry 4: Heating
Indoor unit 1 set temperature	40037			1 to 16 represents 16°C to 30°C
Indoor unit 1 current fan speed	40038			0: Auto, 1: Low 2: Medium, 3: High
Indoor unit 1 current temperature	40039			Integer between -20 and 50I
Indoor unit 1 error code	40040			Integer from 0 to 150

# Address Setting When Using Central Controller

Point description	Protocol address	Extra address	Point type	State
Indoor unit 2 ON/OFF setting	40041		AO (Write)	1: ON, 0: OFF
Indoor unit 2 mode setting	40042			0: Auto, 1: Fan 2: Cooling, 3: Dry 4: Heating
Indoor unit 2 temperature setting	40043			Integer from 16 to 30
Indoor unit 2 fan speed setting	40044			0: Auto, 1: Low 2: Medium, 3: High
Indoor unit 2 ON/OFF state	40045		AI (Read)	1: ON, 0: OFF
Indoor unit 2 mode	40046			0: Auto, 1: Fan 2: Cooling, 3: Dry 4: Heating
Indoor unit 2 set temperature	40047			1 to 16 represents 16°C to 30°C 1 to 16 represents 16°C to 30°C
Indoor unit 2 current fan speed	40048			0: Auto, 1: Low 2: Medium, 3: High
Indoor unit 2 current temperature	40049			Integer between -20 and 50 Integer between -20 and 50
Indoor unit 2 error code	40050			Integer from 0 to 150 Integer from 0 to 150
----	----			----
Indoor unit 64 ON/OFF setting	40661		AO (Write)	1: ON, 0: OFF
Indoor unit 64 mode setting	40662			0: Auto, 1: Fan 2: Cooling, 3: Dry 4: Heating
Indoor unit 64 temperature setting	40663			Integer from 16 to 30
Indoor unit 64 fan speed setting	40664			0: Auto, 1: Low 2: Medium, 3: High

## Address Setting When Using Central Controller

Point description	Protocol address	Extra address	Point type	State
Indoor unit 64 ON/OFF state	40665		AI (Read)	1: ON, 0: OFF
Indoor unit 64 mode	40666			0: Auto, 1: Fan 2: Cooling, 3: Dry 4: Heating
Indoor unit 64 set temperature	40667			1 to 16 represents 16°C to 30°C
Indoor unit 64 current fan speed	40668			0: Auto, 1: Low 2: Medium, 3: High
Indoor unit 64 current temperature	40669			Integer between -20 and 50
Indoor unit 64 error code	40670			Integer from 0 to 150

# Address Setting When Using Central Controller

When controlling single or multi split

1. System structure chart when controlling single split:

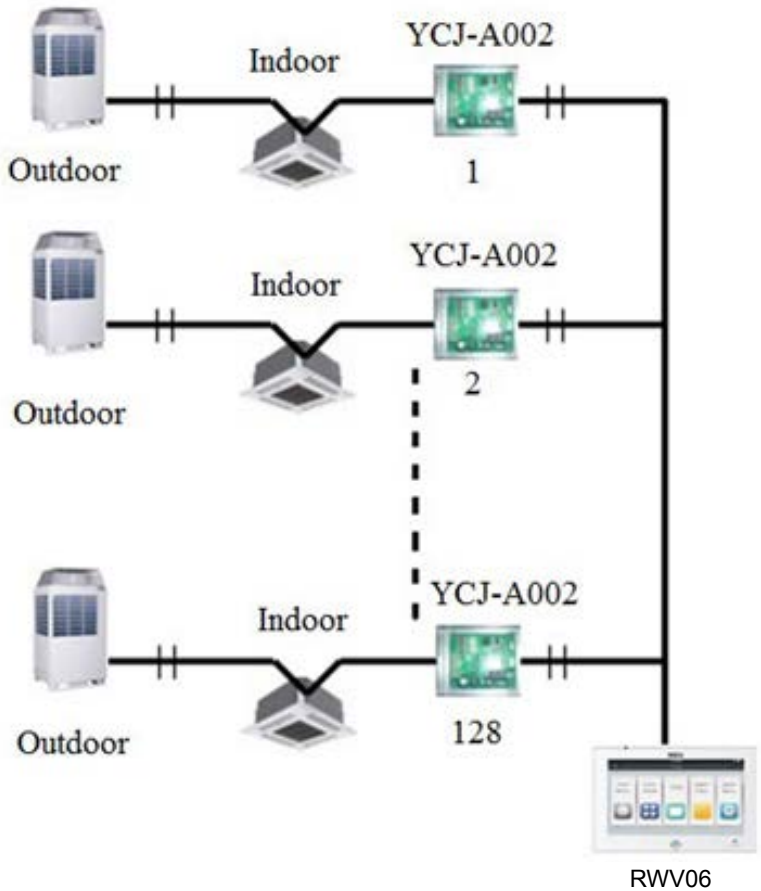

One YCJ-A002 is needed for every indoor unit. Max. 128 YCJ-A002 (as well as max. 128 indoor units) can be connected.



# Address Setting When Using Central Controller

2. One indoor unit needs one converter YCJ-A002, YCJ-A002 addressing as follows:

SW01								Definition
[8]	[7]	[6]	[5]	[4]	[3]	[2]	[1]	
0	--	--	--	--	--	--	--	Single mode
1	--	--	--	--	--	--	--	Twin units shifting mode
--	0	0	--	--	--	--	--	Shifting time 1—8 hours
--	0	1	--	--	--	--	--	Shifting time 2—10 hours
--	1	0	--	--	--	--	--	Shifting time 3—12 hours
--	1	1	--	--	--	--	--	Shifting time 4—14 hours
--	--	--	0	--	--	--	--	Twin units running mode when room temp. $\geq 26^{\circ}\text{C}$
--	--	--	1	--	--	--	--	Twin units running mode when room temp. $\geq 24^{\circ}\text{C}$
--	--	--	--	0	0	0	0	Central address in twin shifting mode=1
--	--	--	--	0	0	0	1	Central address in twin shifting mode=2
----								----
--	--	--	--	1	1	1	0	Central address in twin shifting mode=15
--	--	--	--	1	1	1	1	Central address in twin shifting mode=16
--	0	0	0	0	0	0	0	Central address=1
--	0	0	0	0	0	0	1	Central address =2
----								----
--	1	1	1	1	1	1	0	Central address =127
--	1	1	1	1	1	1	1	Central address=128

RWV06 can control at most 128 indoor units when controlling single or multi split.

# Address Setting When Using Central Controller

## 3. Third party interface

Communication parameter:

Slave ID : 1	
Function code: inquiry 03H; control 10H	
Communication parameter	Point type
Baud rate: 9600	DI: switching value input signal
data bits: 8	DO: switching value output signal
Check bit: None	AI: analog quantity input signal
Stop bit: 1	AO: analog quantity output signal
Start bit: 1, One frame command finished, using CRC to check	

Point table:

Point description	Protocol address	Extra address	Point type	State
All On/All Off	40006		AO (Write)	1: All On 0: All Off
Indoor unit (1—128) ON/OFF setting	40011-40018	0-15	DO (Write)	1: ON 0: OFF
Indoor unit (1—128) ON/OFF state	40019-40026	0-15	DI (Read)	1: ON 0: OFF
Indoor unit (1—128) Malfunction state	40027-40034	0-15	DI (Read)	1: Error 0: Normal
Indoor unit 1 ON/OFF setting	40043		AO (Write)	1: ON, 0: OFF
Indoor unit 1 mode setting	40044			0: Auto, 1: Fan 2: Cooling, 3: Dry 4: Heating
Indoor unit 1 temperature setting	40045			Integer from 16 to 30
Indoor unit 1 fan speed setting	40046			0: Auto, 1: Low 2: Medium, 3: High

# Address Setting When Using Central Controller

Point description	Protocol address	Extra address	Point type	State
Indoor unit 1 ON/OFF state	40047		AI (Read)	1: ON, 0: OFF
Indoor unit 1 mode	40048			0: Auto, 1: Fan 2: Cooling, 3: Dry 4: Heating
Indoor unit 1 set temperature	40049			1 to 16 represents 16°C to 30°C
Indoor unit 1 current fan speed	40050			0: Auto, 1: Low 2: Medium, 3: High
Indoor unit 1 current temperature	40051			Integer between -20 and 50
Indoor unit 1 error code	40052			Integer from 0 to 150
Indoor unit 2 ON/OFF setting	40053		AO (Write)	1: ON, 0: OFF
Indoor unit 2 mode setting	40054			0: Auto, 1: Fan 2: Cooling, 3: Dry 4: Heating
Indoor unit 2 temperature setting	40055			Integer from 16 to 30
Indoor unit 2 fan speed setting	40056			0: Auto, 1: Low 2: Medium, 3: High
Indoor unit 2 ON/OFF state	40057		AI (Read)	1: ON, 0: OFF
Indoor unit 2 mode	40058			0: Auto, 1: Fan 2: Cooling, 3: Dry 4: Heating
Indoor unit 2 set temperature	40059			1 to 16 represents 16°C to 30°C
Indoor unit 2 current fan speed	40060			0: Auto, 1: Low 2: Medium, 3: High
Indoor unit 2 current temperature	40061			Integer between -20 and 50
Indoor unit 2 error code	40062			Integer from 0 to 150
----	----	----	----	----

## Address Setting When Using Central Controller

Point description	Protocol address	Extra address	Point type	State
Indoor unit 128 ON/OFF setting	41313		AO (Write)	1: ON, 0: OFF
Indoor unit 128 mode setting	41314			0: Auto, 1: Fan 2: Cooling, 3: Dry 4: Heating
Indoor unit 128 temperature setting	41315			Integer from 16 to 30
Indoor unit 128 fan speed setting	41316			0: Auto, 1: Low 2: Medium, 3: High
Indoor unit 128 ON/OFF state	41317		AI (Read)	1: ON, 0: OFF
Indoor unit 128 mode	41318			0: Auto, 1: Fan 2: Cooling, 3: Dry 4: Heating
Indoor unit 128 set temperature	41319			1 to 16 represents 16°C to 30°C
Indoor unit 128 current fan speed	41320			0: Auto, 1: Low 2: Medium, 3: High
Indoor unit 128 current temperature	41321			Integer between -20 and 50
Indoor unit 128 error code	41322			Integer from 0 to 150

# Function Operation

## Equipment Settings

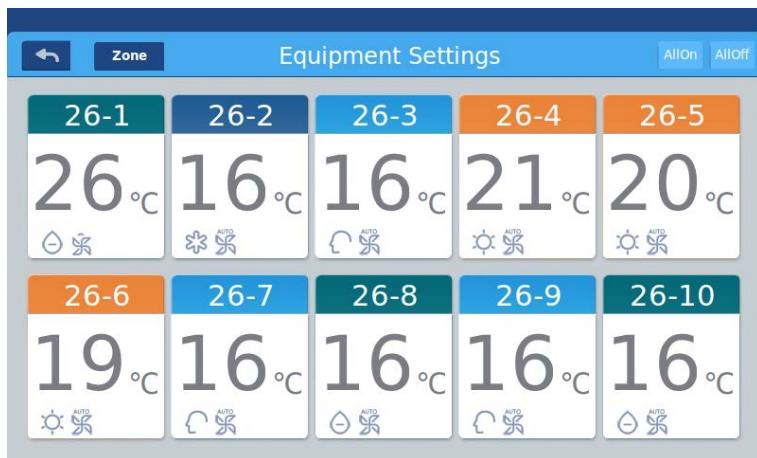

Picture 1

Press the “Equipment Settings” key on home page to enter the display interface as shown in picture 1.

 is the return button. This button is always presented in the column, press this button to return to the last page.

 means you can view air-conditioners as grouping established. Press “Zone” button to pop out all the air-conditioner grouped in pop window. If air-conditioners have not been grouped before, it will show all air-conditioners.

# Function Operation

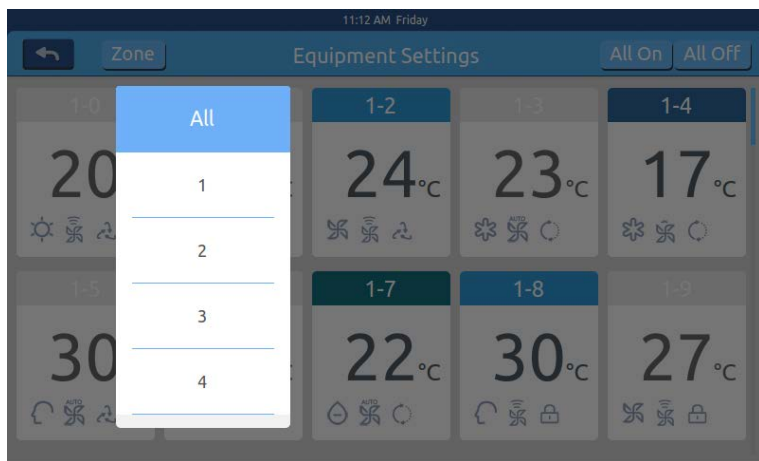

Picture 2

For example: Press the 1 group in picture2, it will show all indoor units on the 1, as shown in picture3.

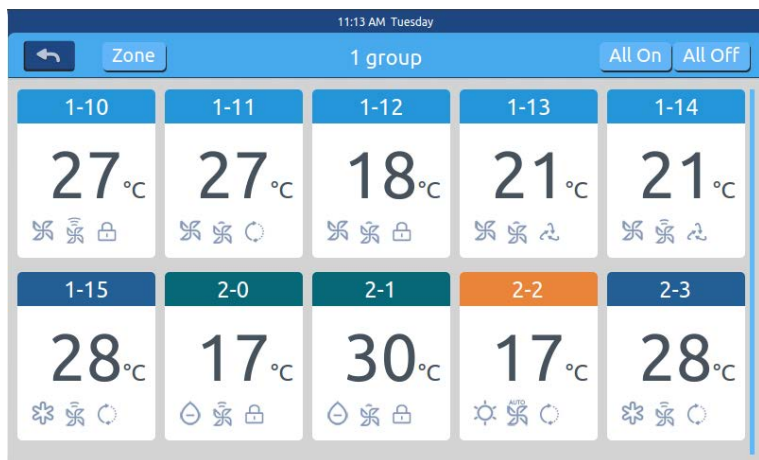

Picture 3

# Function Operation

AllOn AllOff is the All on/All off button. If it is displaying all indoor units, then the All on/All off button is used to control all indoor units; if it is displaying the indoor units of one group, then the All on/All off button is used to control the indoor units in this group.

Each grid represents an indoor unit in the air-conditioner display area, and each page can display 10 indoor units. Slide around the screen to turn pages on the screen. Indoor unit is shown as picture 4.

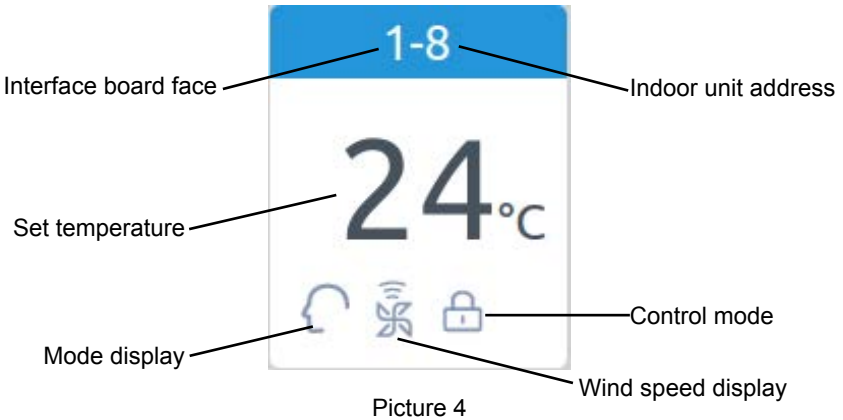

Picture 4

Record: The colors of upper part of the icon represents the operation modes, different mode uses different color to distinguish from each other.

Heating Mode--orange;Cooling Mode--blue; Dry mode--aqua;

Fan mode--wathet;Intelligent Mode--wathet.

# Function Operation

Press single air-conditioner icon to enter the air-conditioner setting interface, as shown in picture5

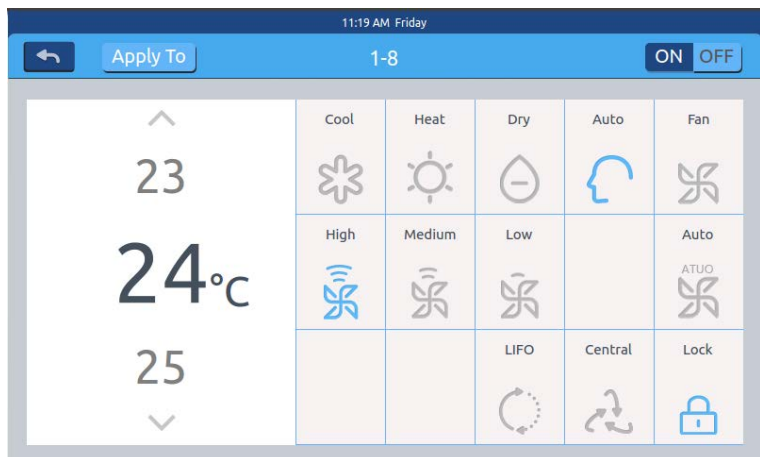

Picture 5

## Setting interface:

**Temperature setting:** You can change the setting temperature by pressing arrow  $\wedge / \vee$ , press once to adjust it one time.

**Record:** In wind mode, the temperature will be gray and can't be changed.

**Set Mode:** Press the corresponding mode icon, the setting is successful if the icon is lighted up. Only one mode can be chosen.

**Set Wind Speed:** Press the corresponding wind speed icon, the setting is successful if the icon is lighted up. Only one wind speed can be chosen.

**Record:** If you choose the fan mode, you can't choose the automatic wind speed any more.













**Set control mode:** Last in first out/Central control/Locked, choose one from these three control mode and the icon will be lighted up (If the current system does not support this setting,the button will be hidden)



# Function Operation

---

## Icon Instruction:

 Cooling Mode	 Last in first out
 Heating Mode	 Central Control
 Dry Mode	 Locked
 Intelligent Mode	 Low Speed
 Wind Mode	 Automatically
 High Speed	 Medium Speed

# Function Operation

Batch change the air-conditioner mode setting: After setting one air-conditioner, press **Apply To** and pop window will pop out as shown in picture 6.

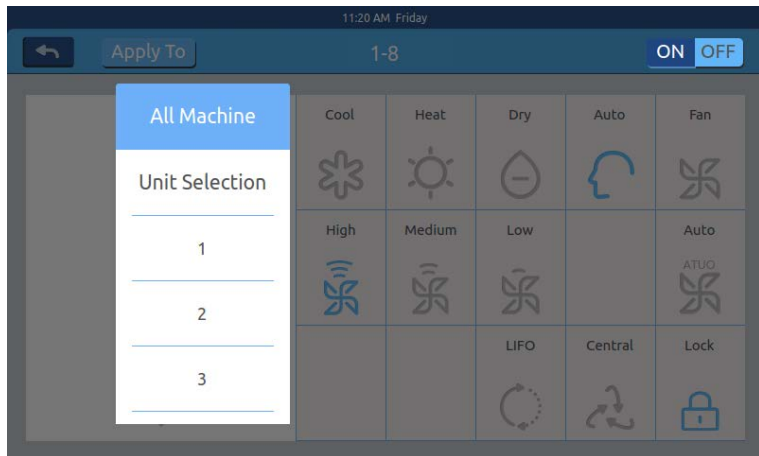

Picture 6

If you choose “All”, then all indoor units will operate as ordered.  
If you choose “indoor unit selection”, then the page will turn to interface displaying all indoor units, press the indoor unit icons to choose the indoor units (the chosen ones will turn to dark color), they will operate as ordered.  
As shown in picture 6, “1st Floor ” “2nd Floor” “3rd Floor” are three parted area, choose one area and all indoor units in this area will operate as ordered.  
Change the name of the air-conditioner: as shown in picture 7, press the air-conditioner number 26-1, then it will display the textbox “please input device name” and click the blank text box to pop out the keyboard. After typing in the name, press “ENTER” to take back the keyboard, then setting name is finished. The longest name can be 12 English letters.

# Function Operation

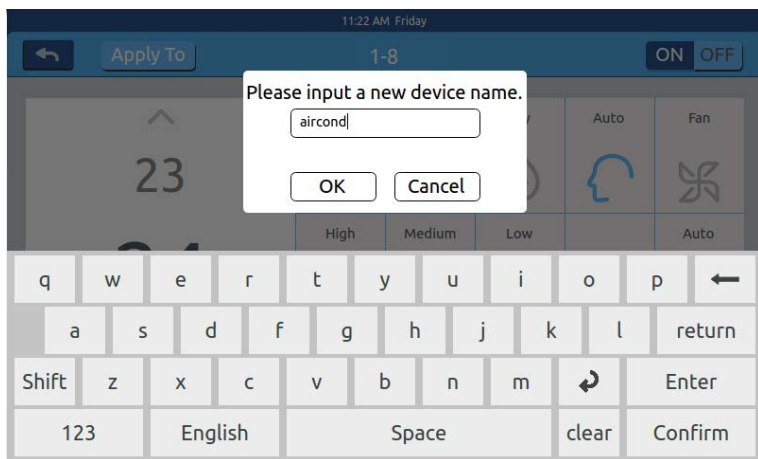

Picture 7

Such as changing the name to “10-16 general manager office”, after changing it will be displayed in center.

## Zone Settings

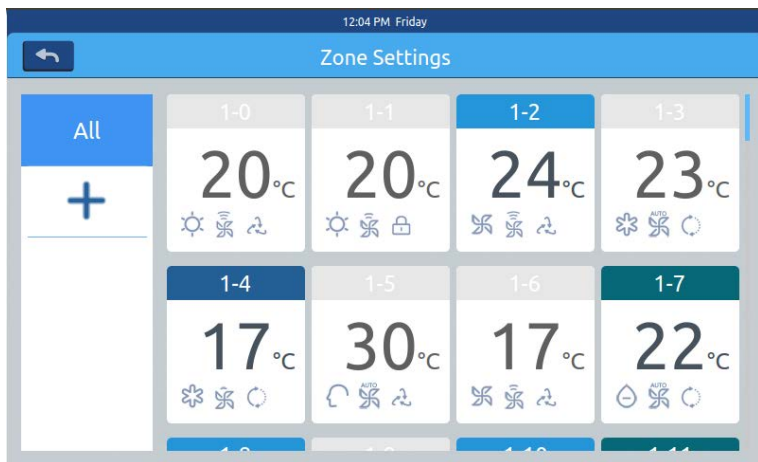

Picture 1

# Function Operation

---

Press zone settings on the homepage to enter the zone setting interface, as shown in picture1.

It will display setting groups and adding new group button on the left. It will only display adding new group button initially. It will display those air-conditioners which can be grouped. It will display all air-conditioners initially.

Adding new group: press  to pop out the window as shown in picture 2.

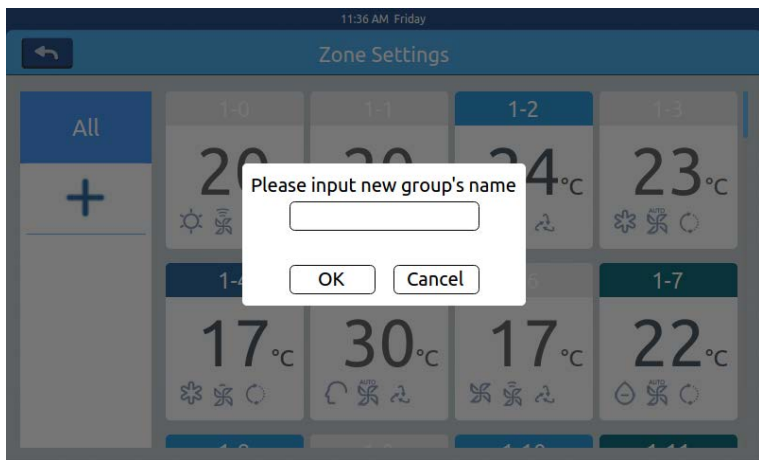

Picture 2

Click the blank text box, enter the group name (up to 12 English letters) by the keyboard, and press the "ENTER" button of the keyboard after entering. Press OK key in the pop window to enter the interface as shown in picture3.

# Function Operation



Picture 3

This interface displays air-conditioner numbers, click to choose those air-conditioners need to be added to grouping. It will turn to blue after being selection, click again to cancel the selection.

For example: choose indoor units 26-1,26-2, it will display as shown in picture 4.



Picture 4

# Function Operation

---

After choosing the air-conditioners, press OK key at the top-right corner, then the grouping is finished, it will create a new group on the left. Click the group name on the left, the background will be highlighted, as these indoor units of the 1st floor area shown in picture5. Each zone supports up to 64 devices. Press  to return to the last layer when grouping air-conditioners.

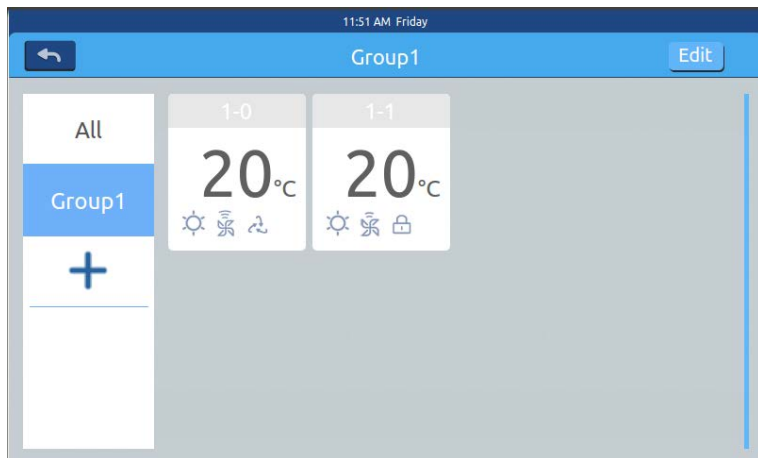

Picture 5

In picture 5, choose one group and then click  button, it will pop out the pop window and it has three lines, as shown in picture6:

# Function Operation

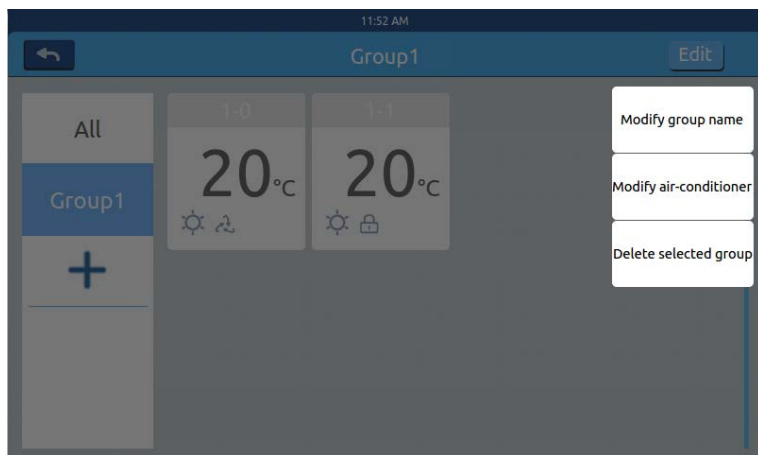

Picture 6

Edit group name: press the key to pop out the pop window of changing the group's name.

Edit group's dev: press the key to pop out the list of indoor units to edit the group's dev.

Remove this group: pop out "to remove this group?" and press OK to delete the group, indoor units will come to "ungrouped", press "cancel" to come back to picture 5.

# Function Operation

## Details

Press details button on homepage to enter detailed information interface as shown in picture1.

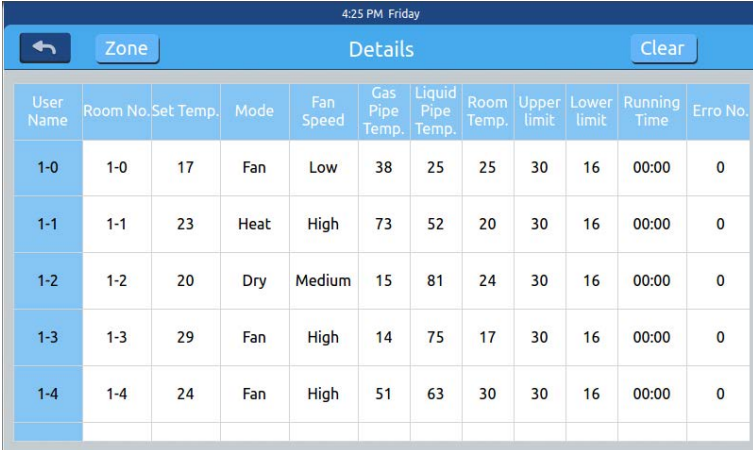

The screenshot shows a mobile application interface titled 'Details' with a timestamp of 4:25 PM Friday. At the top, there is a blue header bar with a back arrow, a 'Zone' button, and a 'Clear' button. Below the header is a table with 12 columns: User Name, Room No., Set Temp., Mode, Fan Speed, Gas Pipe Temp., Liquid Pipe Temp., Room Temp., Upper limit, Lower limit, Running Time, and Erro No. The table contains five rows of data for units 1-0 through 1-4.

User Name	Room No.	Set Temp.	Mode	Fan Speed	Gas Pipe Temp.	Liquid Pipe Temp.	Room Temp.	Upper limit	Lower limit	Running Time	Erro No.
1-0	1-0	17	Fan	Low	38	25	25	30	16	00:00	0
1-1	1-1	23	Heat	High	73	52	20	30	16	00:00	0
1-2	1-2	20	Dry	Medium	15	81	24	30	16	00:00	0
1-3	1-3	29	Fan	High	14	75	17	30	16	00:00	0
1-4	1-4	24	Fan	High	51	63	30	30	16	00:00	0

Picture 1

Vertical axis displays the name of the air-conditioner according to the order of the unit numbers, horizontal axis displays user name, air-conditioner number, setting temperature, setting mode, setting wind speed, gas pipe temperature, liquid pipe temperature, operating time and faults information.

The progress bar is on the right and slide up and down within the progress bar to see all machine details.

Clicking **Clear** to pop out password input window. Inputting password and click "Ok", all current date(except running time) will be cleared. If clicking "Cancel", it will return to previous page.



# Function Operation

## Schedule Settings

Choose Schedule Settings on the homepage to enter the initial schedule setting interface as shown in picture 1.

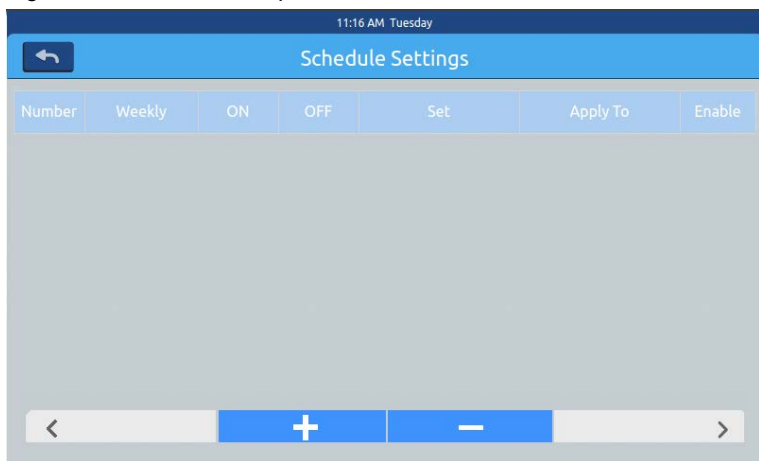

Picture 1

Press **+** to add new schedule settings. Press this button to enter the setting interface, as shown in picture 2, "On" shows when the machine starts up and "Off" shows when the machine shuts down.

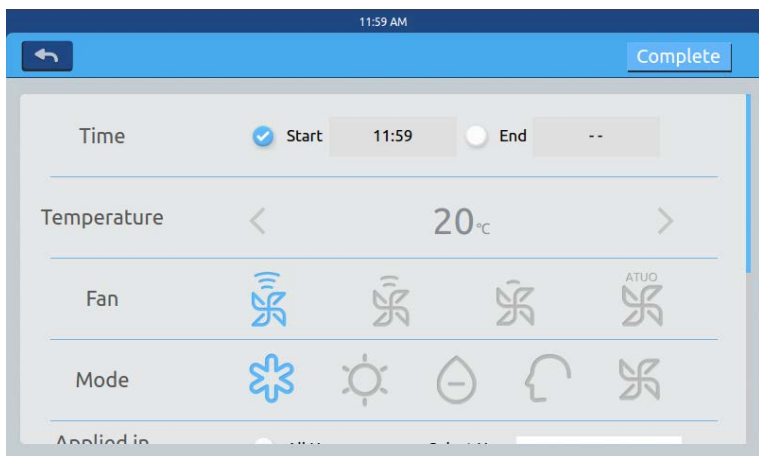

Picture 2

# Function Operation

Click the time text (such as 08:00 in picture 2) to pop out the window

Start Time	
10	58
11	59
12	00

choose the time of startup. Then set the temperature, wind speed and mode. Slide down and set the area applied to and weekly in the interface as shown in picture3.

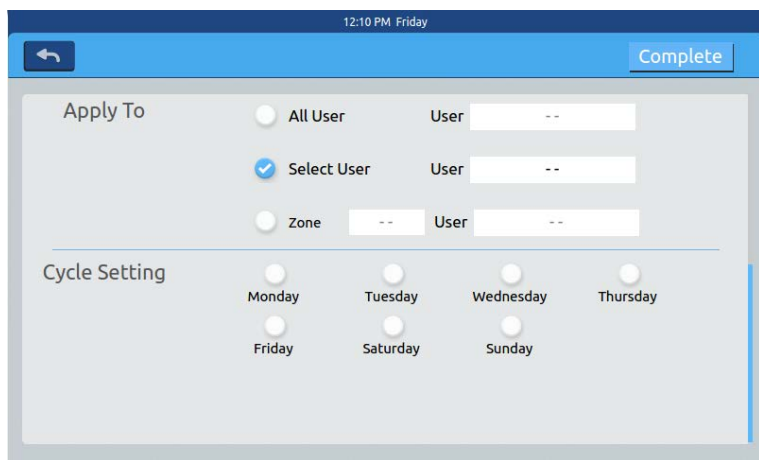

Picture 3

Click "Done" key after setting.

## Apply Zone Settings:

- All select: The default setting is all users. Setting can be changed through the Pop window.
- None select: The default setting is no user. Setting can be changed through the Pop window.
- Zone: Choose zones from the Pop window. Setting can be changed through the Pop window.

Select those indoor units which you want to choose by clicking the frame before them, it will show hook after selection.

After setting the apply area, click blank area and pull-down lists will close.

# Function Operation

## Weekly:

From Monday to Sunday, it will show a hook after click, it will operate the schedule on the day you have chosen, it will circulate weekly.

Schedule will be displayed in the form of picture 4 after set. The table shows the detailed information of this schedule. Click the corresponding item to reset the time, fan speed, mode, and other items as shown in pic picture 2.

Number	Weekly	ON	OFF	Set			Apply To	Enable
1	SMTWTF S	12:10 Pm	--	20°C	High	Cool	1-0,1-1,1-2,1-3...	NO

Picture 4

“Enable”: Set the valid/invalid of the schedule.

“Apply To”: Click the table can check which indoor units will active this schedule (picture 5). This table will show the abbreviated information before opening up the Pop window.

Click “-” to change the state to “-”, click “-” to delete this schedule.

# Function Operation

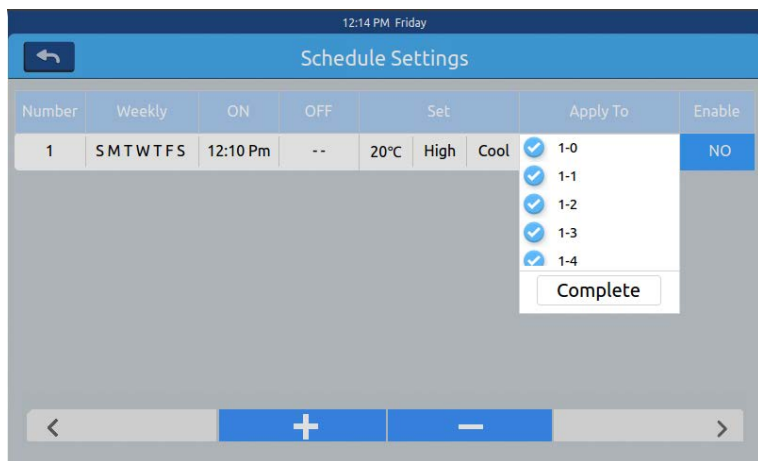

Picture 5

It displays the indoor units above. If there are too many indoor units, you can slide up and down to check them.

## system settings

It need password to enter setting page. Click “system settings” button on the home page, you will see the picture1 below.

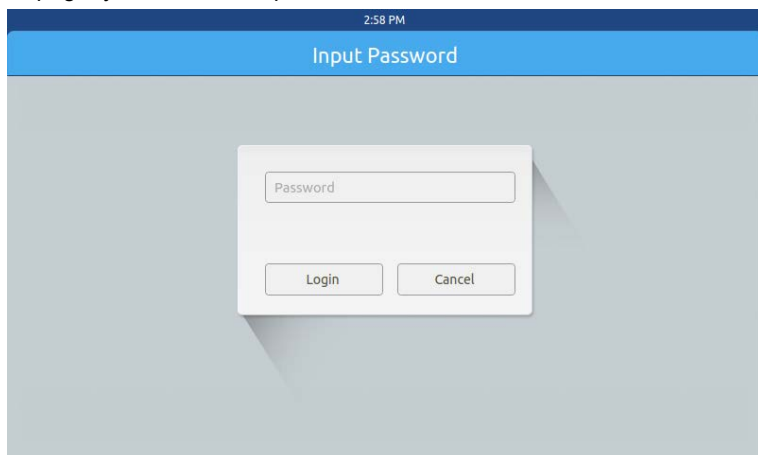

Picture 1

# Function Operation

Click OK key enter system settings page after inputting password. System setting page includes 4 contents, as picture 2, picture 3.

## Local Setting

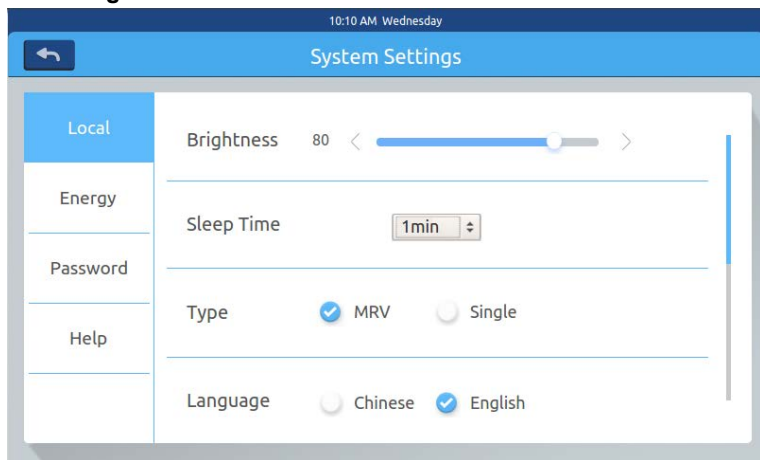

Picture 2

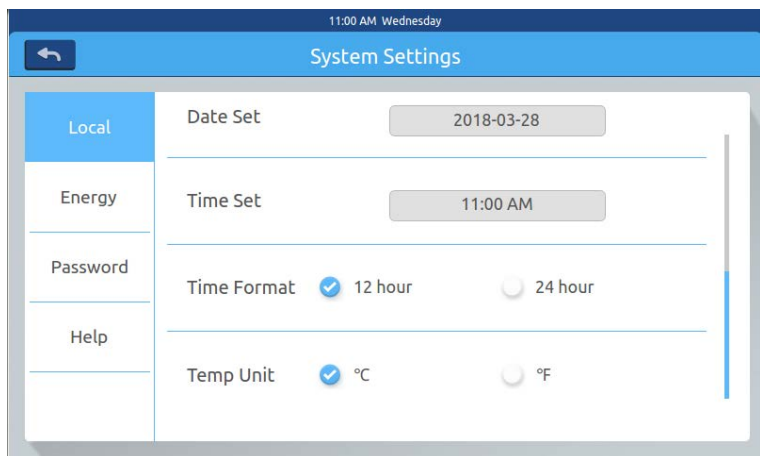

Picture 3

# Function Operation

Brightness: 1-100

Sleep Time: screen saving time can be set: never, 15s, 30s, 1min, 5min, 10min.

You can select the application range from the bottom menu.

Type: Choose your unit model. It will show  after you pitch on the unit type.

Language: Choose language. It will show  after you pitch on the language.

Set date: It will show a date pop window after you click the date box; you can

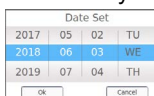

choose the date and week through

Set time: It will show a time pop window after you click the timebox, you



can choose the time through

Hour system: It will show  after you pitch on the time format.

Temperature unit: It will show  after you pitch on the temp. unit.

## Energy Saving

As picture 4, picture 5, picture 6

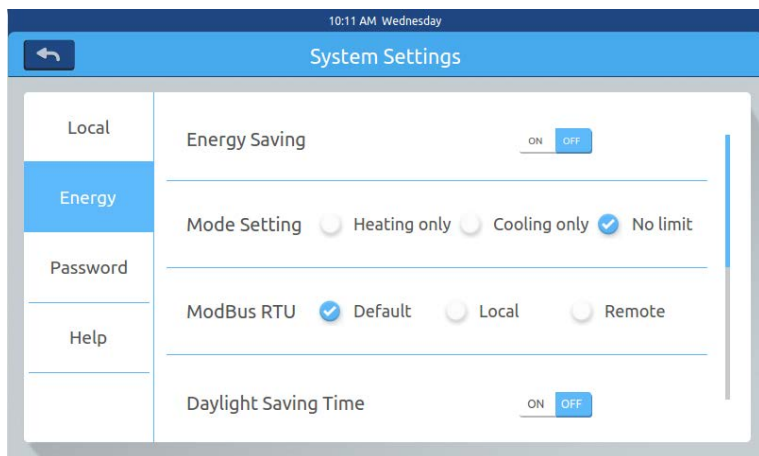

Picture 4

# Function Operation

Energy Saving: You can set saving function through the button  ON  OFF . Default is "ON".

Overrun: click  ON  OFF to turn ON/OFF this function

Overrun time: press < and > to set the overrun time duration.

Temperature maximum setting: You can turn up or down the maximum temperature through operating < or > . After setting, Click  , you will see a pop window what you can choose "apply to all zone" or "apply to one zone". The upper limit and lower limit of temperature take effect only when temperature limit are applied to zone. (when remove temperature upper limit of one zone, need to set upper limit 30 and lower limit 16)

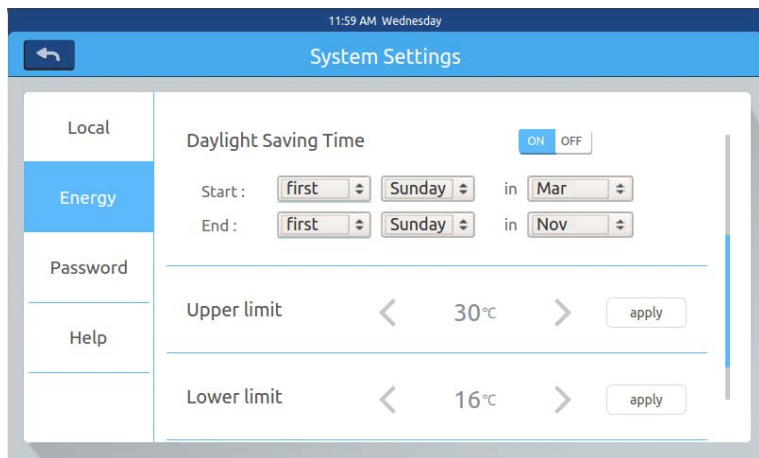

Picture 5

# Function Operation

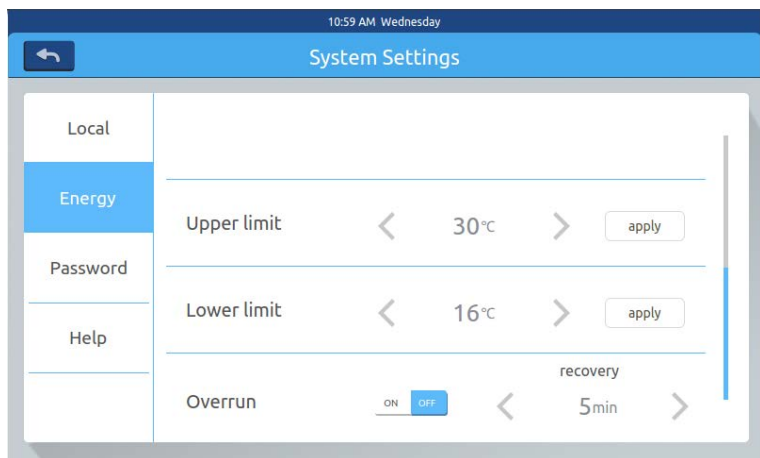

Picture 6

## Password

As picture 7

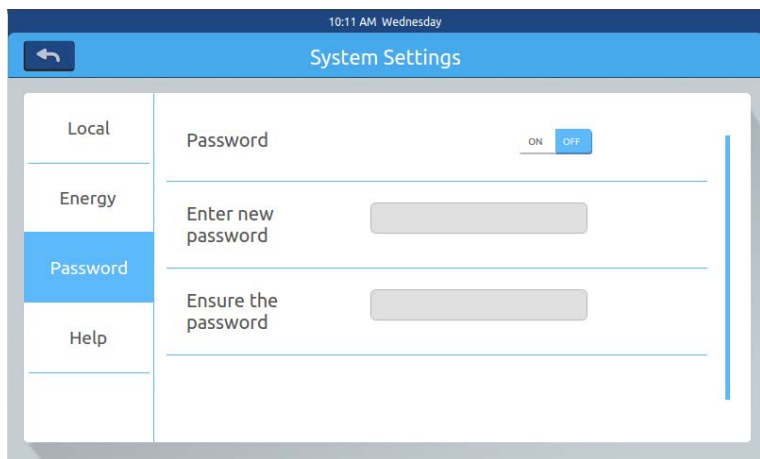

Picture 7



# Function Operation

Screen lock password: Press   to turn ON/OFF the screen lock password.

Password setting: You can choose   to decide if password is necessary.

Input/confirm new password: Input the password (length 4-10) twice. It will remind “update password ok”, the new password will come into effect when you leave this page. Otherwise it will remind “update password fail”.

Remark: default password is 12345.

## Help

Inquire icon definition and version

As picture 8, picture 9

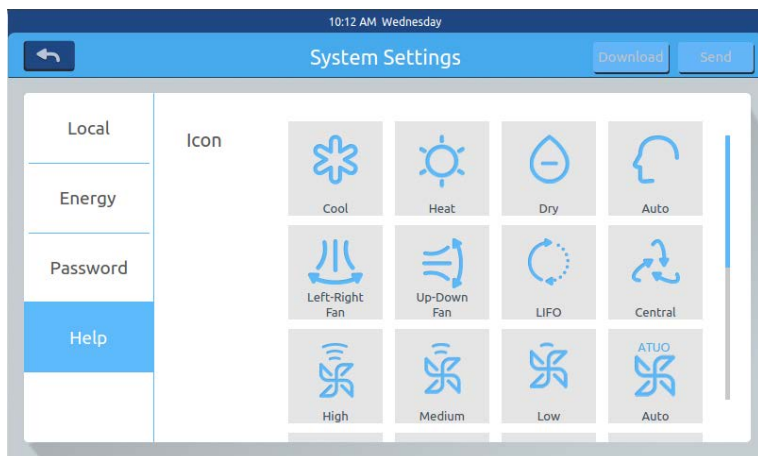

Picture 8

# Function Operation

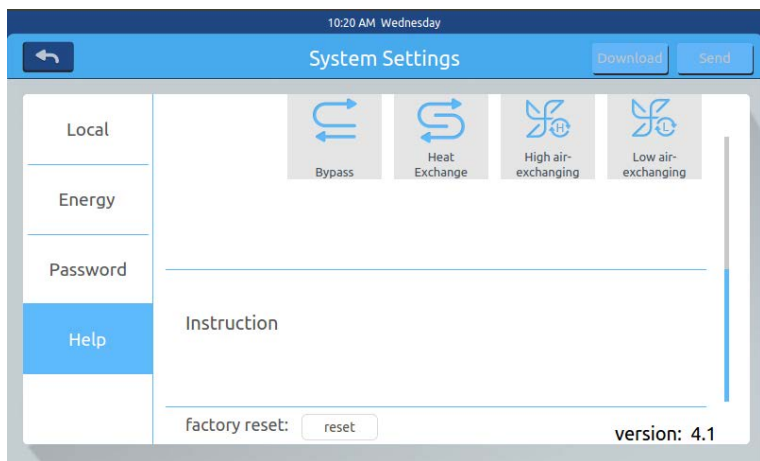

Picture 9

# Installation

## Installation dimension

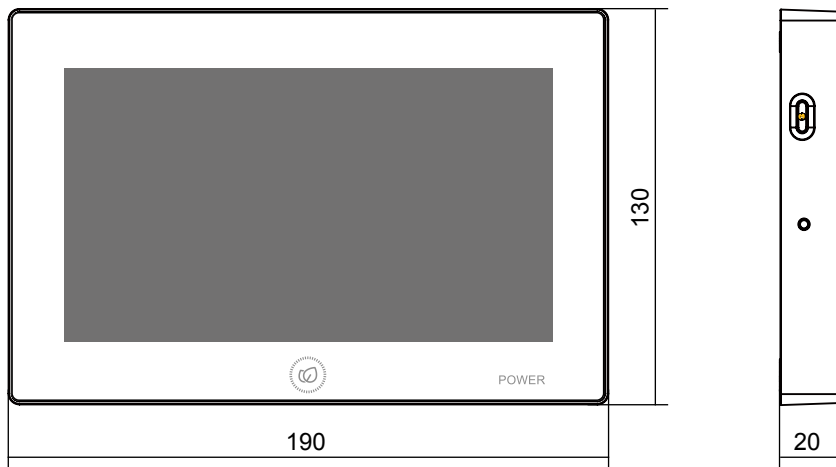

## Wiring diagram

Wiring diagram between central controller and converter board.

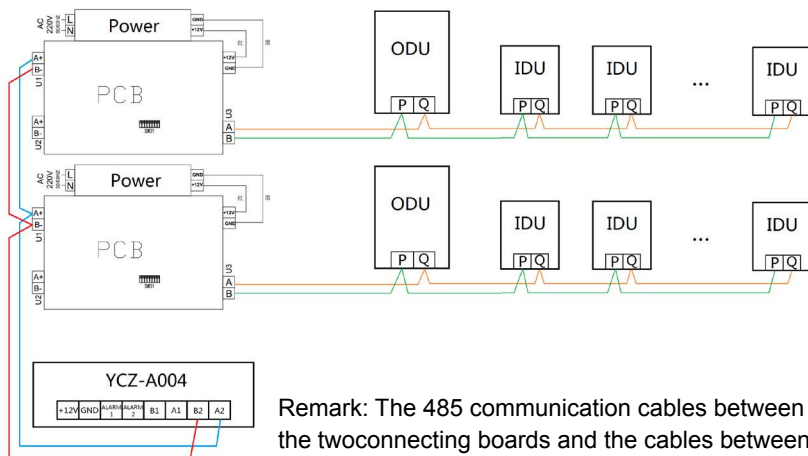

Remark: The 485 communication cables between the two connecting boards and the cables between connecting board and central controller have heteropolarity. Attention please when installing.

# Installation

## Installation dimension

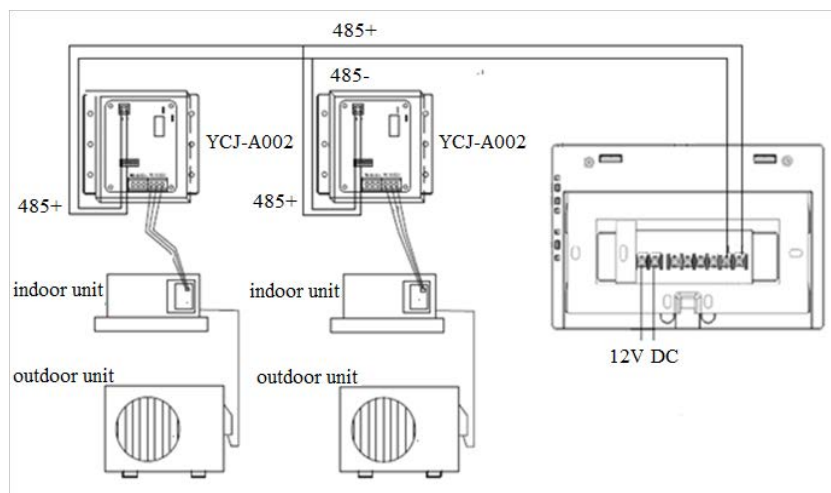

## Wiring standards

All of the communication cables between each module and terminal module to the central controller are double core shielded twisted-pair cable. Specific wiring as the table below.

The length of signal line	Wiring dimension
$\leq 100$	$0.3 \text{ mm}^2 \times 2$
$100 < x \leq 200$	$0.5 \text{ mm}^2 \times 2$
$200 < x \leq 300$	$0.75 \text{ mm}^2 \times 2$
$300 < x \leq 400$	$1.25 \times 2 \text{ mm}^2 \times 2$
$400 < x \leq 500$	$2 \times 2 \text{ mm}^2 \times 2$

# Installation

## Installation condition

Don't install in the place where it is easy to produce noise.

It will be unavailable if it is installed near to the computer, auto-door, elevator, or other equipments what can produce noise.

Don't install in the place where it is wet or shake violent.

It will cause failure if you install in the place where is very wet or shake violent.

Don't install in the place where it is by direct sunlight or near to the heat.

It will cause failure if you install in the place by direct sunlight or near to the heat.

First, fix the rack on the cassette on the wall. Use A and B two holes if it is 120 cassette, use A and C two holes if it is 86 cassette.

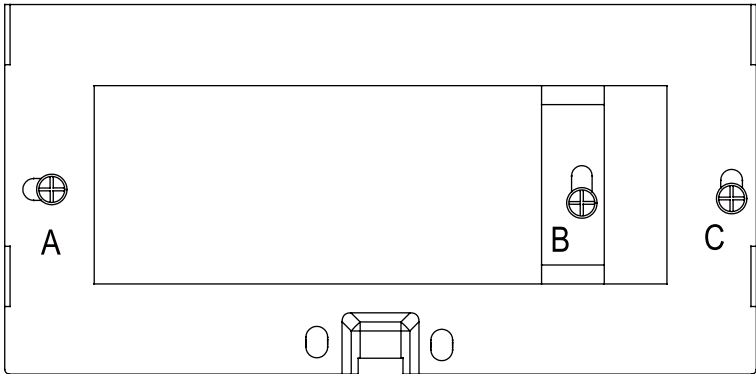

There are two pothooks on each side of the rack. There are four recesses corresponding with the pothooks on the back of the central controller.

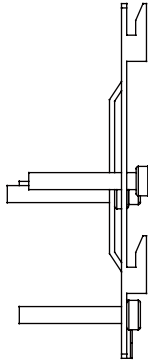

Installation diagram of the side of the rack

# Installation

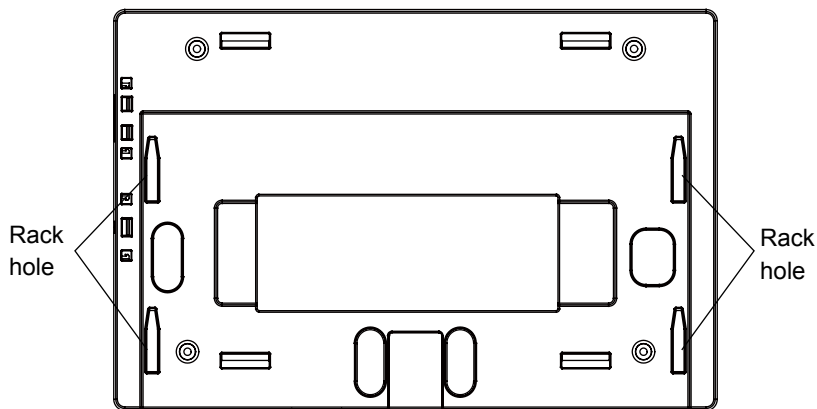

The installation of power adapter

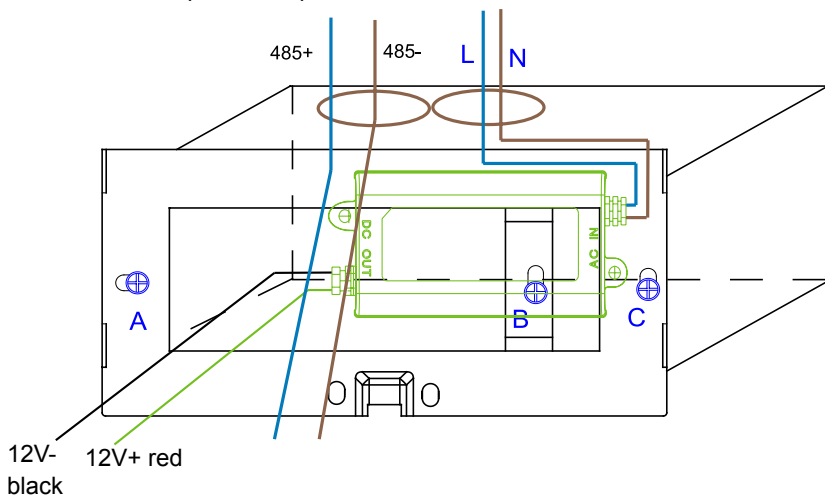

Put the power adapter into the cassette and fix the rack. Put the line of secondary power adapter and the 485 line of converter board out of the rack, and set on the central controller. Then fix the central controller on the rack.

# Installation

## Wiring between power adapter and central controller

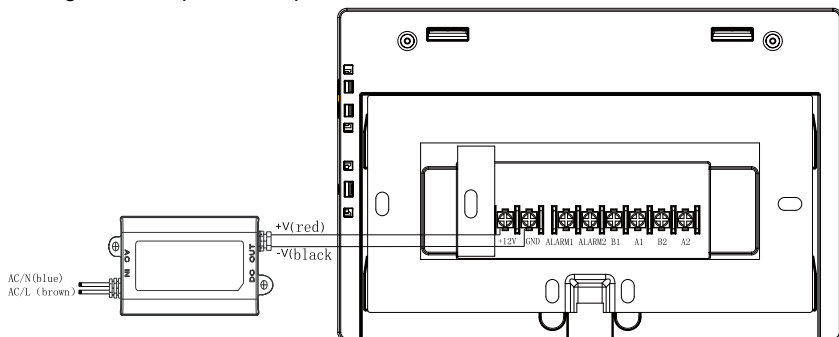

After connection, put the central controller on the rack

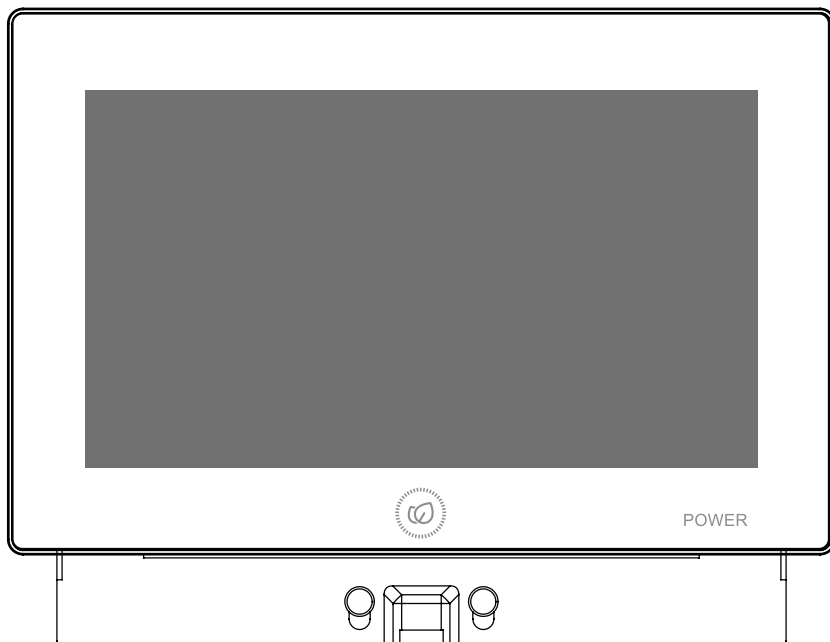

Aim the central controller recesses at pothook, and fix from top to bottom. Then the installation is complete.

