

- FRANÇAIS** CLIMATISEUR CENTRAL AVEC CONTRÔLE ÉLECTRONIQUE  
SPLIT SYSTÈME - SÉRIE CD
- ENGLISH** CENTRAL AIR CONDITIONER WITH ELECTRONIC CONTROL  
SPLIT SYSTEM - SERIES CD
- DEUTSCH** ZENTRALKLIMAANLAGE MIT ELEKTRONISCHER BEDIENUNG  
SPLITSYSTEM - SERIE CD
- ESPAÑOL** AIRE ACONDICIONADO CENTRAL CON CONTROL ELECTRÓNICO  
SISTEMA DE DOS BLOQUES - SERIE CD
- ITALIANO** CLIMATIZZATORE CENTRALIZZATO A CONTROLLO ELETTRONICO  
SISTEMA SPLIT - SERIE CD
- РУССКИЙ** ЦЕНТРАЛЬНЫЙ КОНДИЦИОНЕР С ЭЛЕКТРОННЫМ УПРАВЛЕНИЕМ  
РАЗДЕЛЬНАЯ СИСТЕМА - СЕРИЯ CD

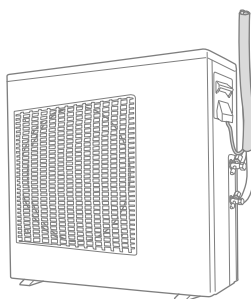
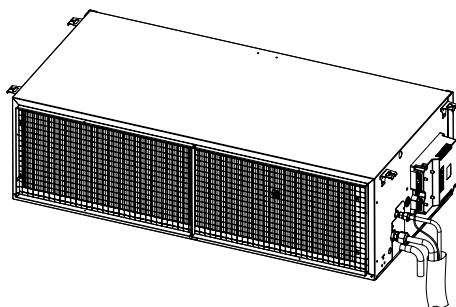

**INSTRUCTIONS POUR L'INSTALLATION**  
**INSTALLATION INSTRUCTIONS**  
**AUFSTELLUNGSANLEITUNG**  
**INSTRUCCIONES DE INSTALACIÓN**  
**MANUALE PER L'INSTALLAZIONE**  
**ИНСТРУКЦИИ ПО УСТАНОВКЕ**

# CENTRAL AIR CONDITIONER WITH ELECTRONIC CONTROL

## SPLIT SYSTEM SERIES CD

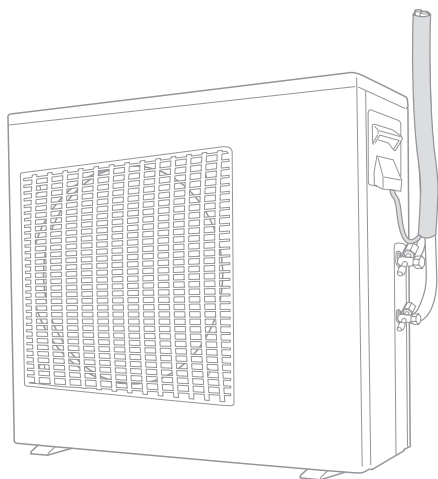
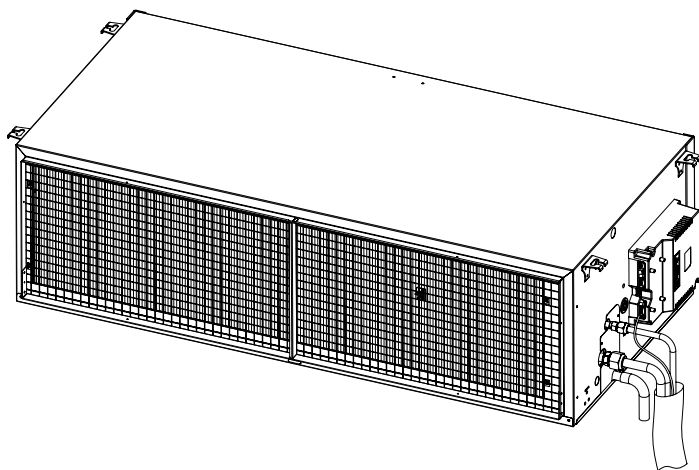

**INSTALLATION INSTRUCTION**

# Getting started...

## REQUIRED TOOLS LIST

1. Screw driver	8. Gas leak detector	15. Torque wrench
2. Electric drill, hole core drill ( 60 mm)	9. Measuring tape	18 N m (1.8 kgf.m)
3. Hexagonal wrench	10. Thermometer	45 N m (4.5 kgf.m)
4. Spanner	11. Megameter	65 N m (6.5 kgf.m)
5. Pipe cutter	12. Multimeter	75 N m (7.5 kgf.m)
6. Reamer	13. Vacuum pump	85 N m (8.5 kgf.m)
7. Knife	14. Gauge manifold (for R-410A)	

## SAFETY PRECAUTIONS

Read the following "SAFETY PRECAUTIONS" carefully before installation. Electrical work must be installed by a licensed electrician. Be sure to use the correct rating of the power plug and main circuit for the model to be installed.

The caution items stated here must be followed because these important contents are related to safety. The meaning of each indication used is as below. Incorrect installation due to ignoring of the instruction will cause harm or damage, and the seriousness is classified by the following indications.

### WARNING

- Use qualified installer and follow careful this instructions, otherwise it will cause electrical shock, water leakage, or aesthetic problem.
- Install at a strong and firm location which is able to withstand the set's weight. If the strength is not enough or installation is not properly done, the set will drop and cause injury.
- For electrical work, follow the local national wiring standard, regulation and this installation instruction. An independent circuit and single outlet must be used. If electrical circuit capacity is not enough it will cause electrical shock or fire.
- Use the specified cable and connecting tightly for indoor/outdoor connection. Connect tightly and clamp the cable so that no external force will be acted on the terminal. If connection or fixing is not perfect, it will cause heat-up or fire at the connection.
- Wire routing must be properly arranged so that control board cover is fixed properly. If control board cover is not fixed perfectly, it will cause heat-up at connection point of terminal, fire or electrical shock.
- Before obtaining access to terminals, all supply circuits must be disconnected.

## ATTENTION

- Selection of the units location.  
Select a location which is rigid and strong enough to support or hold the unit, and select a location for easy maintenance.
- Do not release refrigerant during piping work for installation, reinstallation and during repairing a refrigeration parts. Take care of the liquid refrigerant, it may cause frostbite.
- Installation work. It may need two people to carry out the installation work.
- Do not install this appliance in a laundry room or other location where water may drip from the ceiling, etc.

Carry out test running to confirm that no abnormality occurs after the installation. Then, explain to user the operation, care and maintenance as stated in instructions. Please remind the customer to keep the operating instructions for future reference.

The items to be followed are classified by the symbols:





 **WARNING**  
This indication shows the possibility of causing death or serious injury.

 Symbol with background white denotes item that is PROHIBITED from doing.

## Contents:

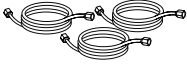
<b>Installation/Service Tooling</b> .....	3
Attached Accessories	
<b>General information</b> .....	4
<b>General precautions</b> .....	5
Drainage installation	
<b>Indoor unit</b> .....	6
Access to the unit	
Unit installation	
<b>Outdoor unit</b> .....	7
Unit dimensions	
Several outdoor installation	
Disposal of outdoor unit	

<b>Pipes connections</b> .....	8
Cutting and flaring	
Pipe insulation	
Pipe connections to unit	
Evacuation of pipes and indoor unit	
<b>Electrical connections</b> .....	9
<b>Display Control Unit</b> .....	11
<b>Check list before operation</b> .....	12
Care and maintenance	
Air volume/static pressure table	
<b>Air filter access</b> .....	13

Installation/Service Tooling for R410A		Changes
Gauge manifold 		As the working pressure is high, it is impossible to measure the working pressure using conventional gauges. In order to prevent any other refrigerant from being charged, the port diameters have been changed.
Charge hose 		In order to increase pressure resisting strength, hose materials and port sizes have been changed (to 1/2 UNF 20 threads per inch). When purchasing a charge hose, be sure to confirm the port size.
Electronic scale for refrigerant charging 		As working pressure is high and gasification speed is fast, it is difficult to read the indicated value by means of charging cylinder, as air bubbles occur.
Torque wrench (nominal dia. 1/2, 5/8) 		The size of opposing flare nuts have been increased. Incidentally, a common wrench is used for nominal diameters 1/4 and 3/8.
Flare tool (clutch type) 		By increasing the clamp bar's receiving hole size, strength of spring in the tool has been improved.
Gauge for projection adjustment		Used when flare is made by conventional flare tool.
Vacuum pump adapter & check valve		Connected to a conventional vacuum pump. It is necessary to use an adapter to prevent vacuum pump oil from flowing back into the charge hose. The charge hose connecting part has two ports -- one for conventional refrigerant (7/16 UNF 20 threads per inch) and one for R410A. If the vacuum pump oil (mineral) mixes with R410A a sludge may occur and damage the equipment.
Gas leakage detector 		Exclusive for HFC refrigerant.

*Incidentally, the "refrigerant cylinder" comes with the refrigerant designation (R410A) and protector coating in the U.S's ARI specified rose colour (ARI colour code: PMS 507). Also, the "charge port and packing for refrigerant cylinder" requires 1/2 UNF 20 threads per inch corresponding to the charge hose's port size.*

#### CAUTION R410A Air Conditioner Installation

THIS AIR CONDITIONER ADOPTS THE NEW HFC REFRIGERANT (R410A) WHICH DOES NOT DESTROY OZONE LAYER. R410A refrigerant is apt to be affected by impurities such as water, oxidizing membrane, and oils because the working pressure of R410A refrigerant is approx. 1.6 times of refrigerant R22. Accompanied with the adoption of the new refrigerant, the refrigeration machine oil has also been changed. Therefore, during installation work, be sure that water, dust, former refrigerant, or refrigeration machine oil does not enter into the new type refrigerant R410A air conditioner circuit. To prevent mixing of refrigerant or refrigerating machine oil, the sizes of connecting sections of charging port on main unit and installation tools are different from those used for the conventional refrigerant units. Accordingly, special tools are required for the new refrigerant (R410A) units. For connecting pipes, use new and clean piping materials with high pressure fittings made for R410A only.

Moreover, do not use the existing piping because there are some problems with pressure fittings and possible impurities in existing piping.

**Do not vent R410A into atmosphere. R410a is a fluorinated greenhouse gas, covered by Kyoto Protocol, with a global warming potential (GWP) = 1725.**

#### Changes in the product and components











In air conditioners using R410A, in order to prevent any other refrigerant from being accidentally charged, the service port diameter size of the outdoor unit control valve (3 way valve) has been changed. (1/2 UNF 20 threads per inch).

In order to increase the pressure resisting strength of the refrigerant piping, flare processing diameter and opposing flare nuts sizes have been changed. (for copper pipes with nominal dimensions 1/2 and 5/8).

In case of pipes welding please make sure to use dry Nitrogen inside the pipes.

Use copper tube of special thickness for R410A: 1/4"-1/2" 0.8 mm  
5/8"-3/4" 1 mm  
7/8" 1.1 mm

#### ATTACHED ACCESSORIES

Description	Amount	Name	USE
	1	Technician's installation manual	Installation instructions
	1	Instruction manual for remote control	Operation instructions for remote
	1	Instruction manual for unit dispaaly	Operation instructions
	1	Remote control including batteries	Operating the air-conditioner
	1	Remote control bracket	Hanging the remote control on the wall
	1	Central control display	Operating and main working display
	4	Rubber mounting pads	Padding of the outdoor unit
	4	Tie - Wraps	Tightening the indoor and the outdoor units electrical cables
	4each	Dibbles - Screws - Washers	Installing bracket for remote control and central control display
	1	Drain elbow	Connecting drain hose to outdoor

**GENERAL INFORMATION**

**Indoor Unit**

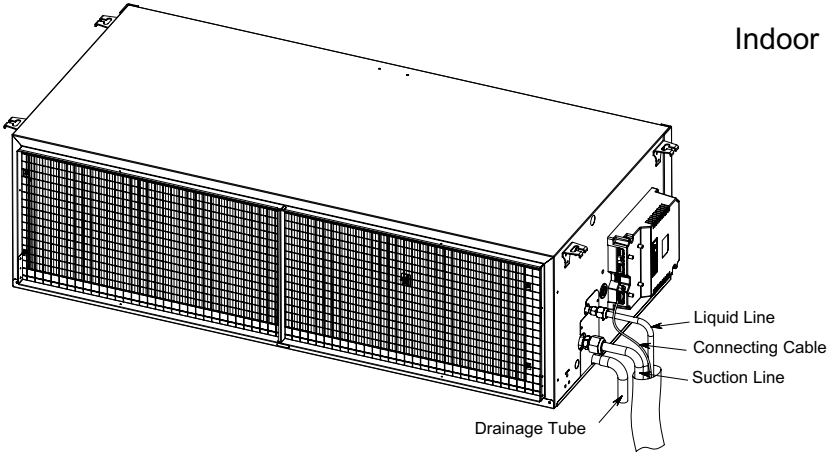

**Outdoor Unit**

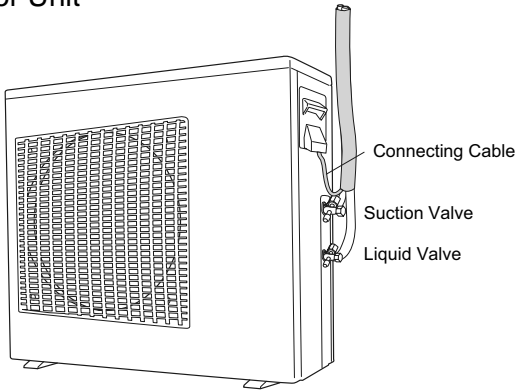

**MAXIMUM PIPES LENGTH & HEIGHT**

NOMINAL CAPACITY	TUBES O.D	LENGTH (A)	HEIGHT (B)
17.0kW	1/2" - 7/8"	50m	25m

**EXTERNAL STATIC PRESSURE**

NOMINAL CAPACITY	NOMINAL	MIN - MAX
17.0kW	140 Pa	140 - 200 Pa

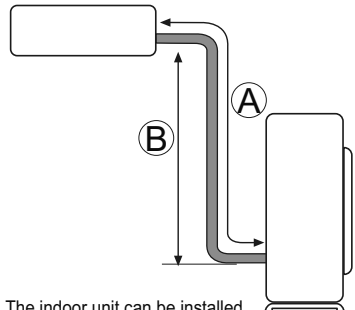

The indoor unit can be installed also below the outdoor unit.

## GENERAL PRECAUTIONS

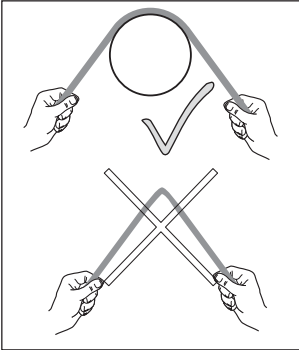

Always use the support of a large radius cylinder for banding the tubes using pipe bending tools.

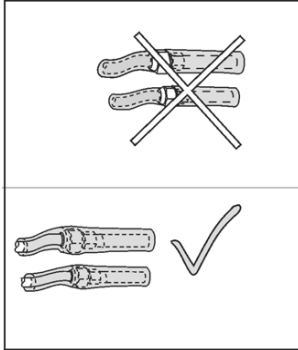

Do not leave nuts of gas tube uncovered.

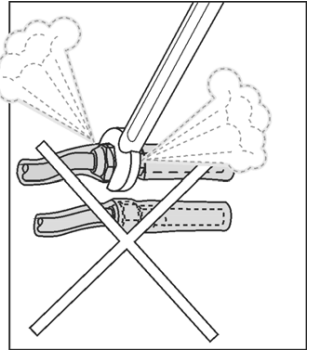

Do not tie gas tubes after installation.

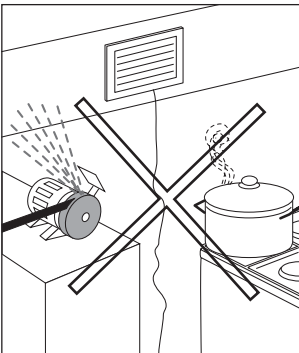

Avoid placing the indoor unit near water or oily mist.

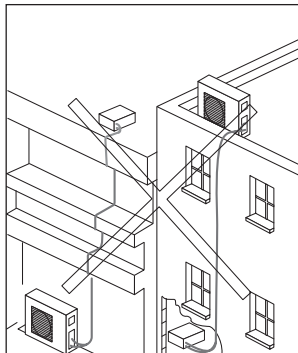

Avoid pipes bending and keep pipes as short as possible.

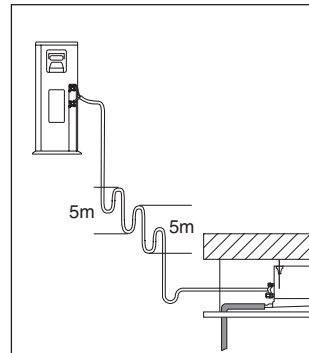

Oil trap for units up to 5kW.  
In case the outdoor unit is under the indoor unit no trap is required.

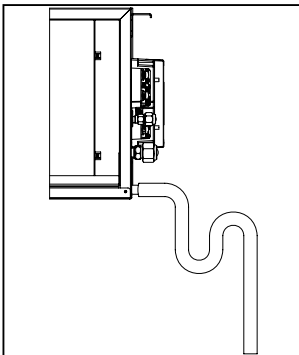

- For assuring a correct operation of the draining system, pay attention to the following points:
- Draining tubes should be slanted down at an angle of at least 2°. Up slanting should be avoided to prevent liquid back-flow.
  - Use always 19 mm diameter tube for draining.
  - Making of a water trap (Siphon) will prevent bad odors and assure proper drainage.

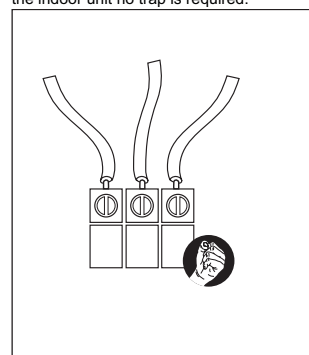

Tighten electrical circuits cables.

## UNIT LOCATION

While selecting a place for the indoor unit:

- Allow max. air flow to the desired space
- Allow max return air flow
- Ensure adequate drainage of condensed water
- Ensure noise reduction near bedrooms
- Leave a minimum 250 mm free space in front of the filter
- Allow a free service access to electrical box.
- Allow easy access to the base of the indoor unit while providing enough space from the ceiling
- Use serrated rubber under the unit and flexible joints to avoid resonance vibrations

## UNIT DIMENSION

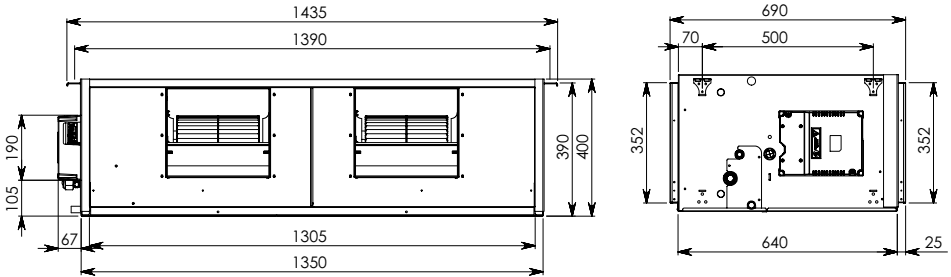

## CLEARANCE AROUND THE UNIT

SERVICE ACCESS FROM THE BOTTOM OF THE UNIT

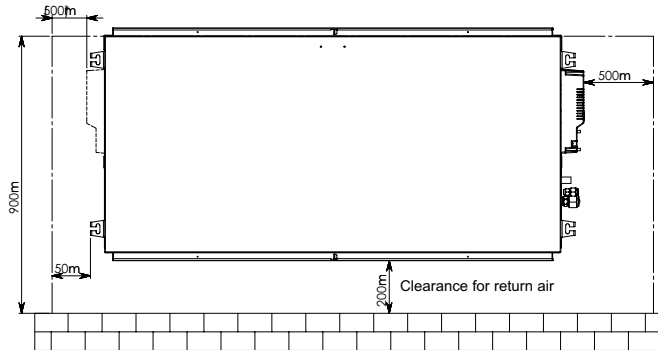

\* For right units, switch between both dimensions.

## UNIT INSTALLATION

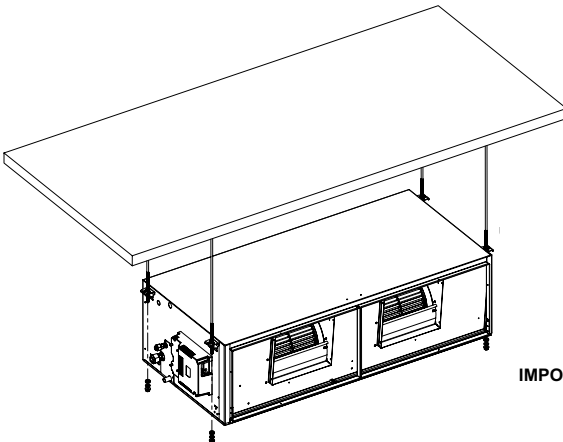

- Insert 4 M10 or 3/8" threads rods into the ceiling.
- Introduce the rods through the slots of unit suspension brackets.
- Position the shock absorbers, add washers and screw the nuts until the unit is firmly supported.
- In case of a gap between the unit and the ceiling, put a rubber or a neoprene sheet.

**IMPORTANT!** The unit must be perfectly levelled.

## OUTDOOR UNIT

### UNIT DIMENSIONS

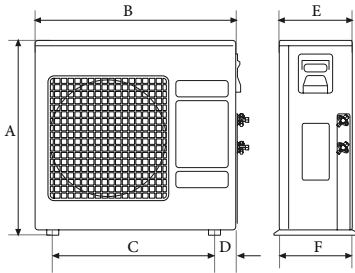

NOMINAL CAPACITY	A	B	C	D	E	F
17.0 kW	1250	900	705	97	340	357

### CLEARANCES AROUND THE UNIT

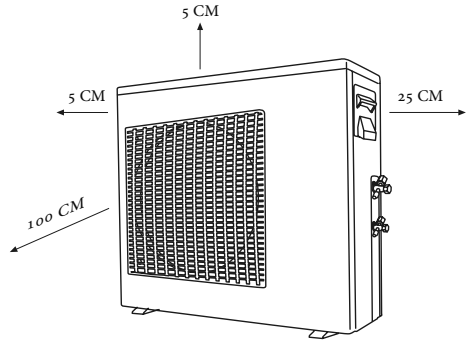

### SEVERAL OUTDOORS INSTALATION

When installing several outdoors units please take into account the air flow around the units and follow the minimum distance suggestions as shown in the diagrams below.

#### Row Installation

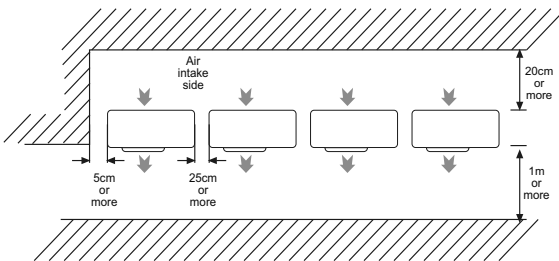

#### Back to Back Front to Front

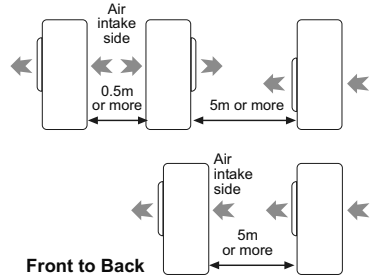

### DISPOSAL OF OUTDOOR UNIT DRAIN WATER

In case of using a drain elbow, the unit should be placed on a stand at least 3 cm high.

Install the hose with a downward to allow smooth flow of draining water.

Use 16mm I.D. tube for drainage.

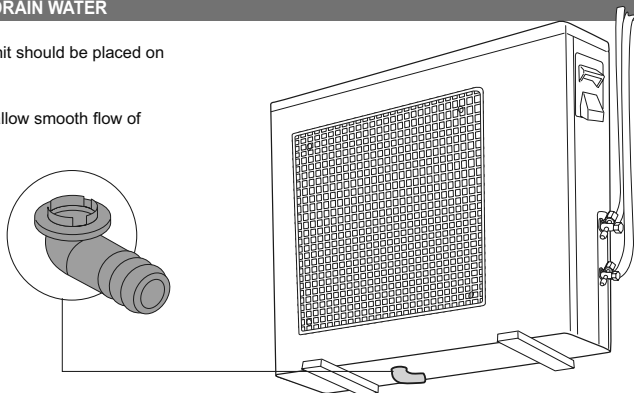



## PIPES CONNECTIONS

### CUTTING AND FLARING THE PIPES

1. Please use the pipe cutter for cutting the pipes.
2. Remove all burrs by using reamer. Gas leakage might happen if burrs are not removed!  
Turn pipes edge down to avoid metal powder from entering down the pipes.
3. After inserting the flare nut into the copper pipes, please make a flare.

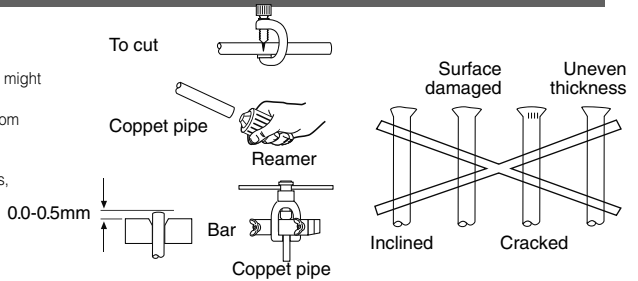

### PIPE INSULATION

1. Please carry out insulation at pipe connection portion as mentioned in Indoor/ Outdoor Unit Installation Diagram. Please wrap the insulated piping end to prevent water from going inside the piping.
2. If drain hose or connecting pipes is in the room (where dew may form). Please increase the insulation by using POLY-E FOAM with thickness of 9 mm or more.

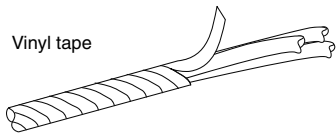

### PIPES CONNECTIONS TO THE UNIT

#### Connecting to the indoor unit

1. Align the center of the pipes and finger tight the flare nut.
2. Use the torque wrench to tighten the nut firmly.

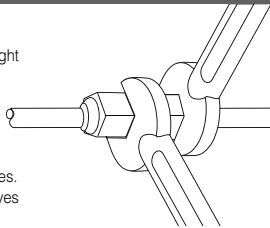

#### Connecting to the outdoor unit

1. Align the center of the pipes to the valves.
2. Use the torque wrench to tighten the valves firmly according to table:

Torque(N.m)	1/4	3/8	1/2	5/8	3/4
Flare Nuts	13-18	40-45	60-65	70-75	80-85
Valve Cap	13-20	13-20	18-25	18-25	40-50
Service Port Cap	11-13	11-13	11-13	11-13	11-13

### EVACUATION OF PIPES AND INDOOR UNIT

After connection the unions of the indoor and outdoor units, evacuate the air from the tubes and from the indoor unit as the follow

1. Connect the charging hoses with a push pin to the low and high sides of the charging set and the service port of the suction and liquid valves. Be sure to connect the end of the charging hose with the push pin to the service port.
2. Connect the center hose of the charging set to a vacuum pump.
3. Turn on the power switch of the vacuum pump and make sure that the needle in the gauge moves from OMPa (0cm Hg) to - 0.1 MPa (-76cm Hg). Let the pump run for fifteen minutes.
4. Close the valves of both the low and high sides of the charging set and turn off the vacuum pump. Note that the needle in the gauge should not move after approximately five minutes.
5. Disconnect the charging hose from the vacuum pump and from the service ports of the suction and liquid valves.
6. Tighten the service port caps from both valves, and open them using a hexagonal Allen wrench.
7. Remove the valve caps from both valves, and open them using a hexagonal Allen wrench.
8. Remount valve caps onto both of the valves.
9. Check for gas leaks from the four unions and from the valve caps. Test with electronic leak detector or with a sponge immersed in soapy water for bubbles.

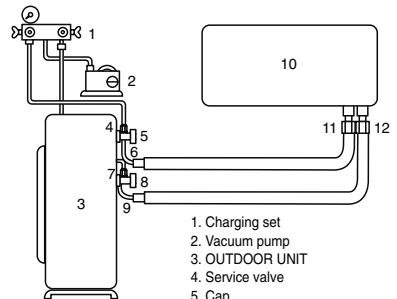

1. Charging set
2. Vacuum pump
3. OUTDOOR UNIT
4. Service valve
5. Cap
6. Suction valve
7. Service valve\*
8. Cap
9. Liquid valve
10. INDOOR UNIT
11. Suction flare connection
12. Liquid flare connection

#### Sample

CAPACITY AND ADDITIONAL CHARGE FOR VARIOUS APPLICATIONS					
INDOOR	WVG 36	FXD 36	ECF XL 36	DNG 36	
COOLING CAPACITY	FLD 36	IX 36	FXL 36	DLS 36	
HEATING CAPACITY	HXE 80	TXE 80	CXE 80	NLS 80	
PIPE LENGTH	2000 ft	2000 ft	2000 ft	2000 ft	2000 ft
CAPACITY	8700 W	8700 W	8700 W	8700 W	8700 W
Indoor Unit	0 gram	0 gram	0 gram	0 gram	0 gram
Indoor Unit	440gram	440gram	440gram	440gram	440gram
Indoor Unit	N/A	N/A	N/A	N/A	1140gram

REFRIGERANT R410A

Cell No. 43379461

NOTE: For additional charge of various tubing lengths, refer to outdoor unit table.

## ELECTRICAL CONNECTIONS

### ELECTRICAL SPECIFICATIONS

#### POWER SUPPLY

400V / 50Hz / 3PH

Electrical wiring and connections should be made by qualified electricians in accordance with local electrical codes and regulation. The air conditioner units must be grounded.

The air conditioner units must be connected to an adequate power outlet from a separate branch circuit protected by a time delay circuit breaker, as specified on unit's nameplate. Voltage should not vary beyond  $\pm 10\%$  of the rated voltage.

For all power supply connections to the outdoor unit, also for the connecting cable between indoor and outdoor unit, only HO5RN-F (60245 IEC 57) cable is to use. For the optional power supply on the indoor unit at least HO5VV-F (60227 IEC 53) is to use

1. Prepare the multiple wire cable ends for connection.
2. Take away the Indoor/outdoor cover and open the terminals, take away the cable clamp screw and turn over the cable clamp.
3. Connect the cable ends to the terminals of the indoor and outdoor units.
4. Connect the other end of the twin wire cable to the outdoor unit twin wire terminal.
5. Secure the multiple wire power cable with the cable clamps.

NOMINAL CAPACITY	CIRCUIT BRAKER	POWE SUPPLY CABLE	POWE SUPPLY SIDE
17.0 kW	3 x 20A	5 x 2.5 mm <sup>2</sup>	TO OUTDOOR UNIT

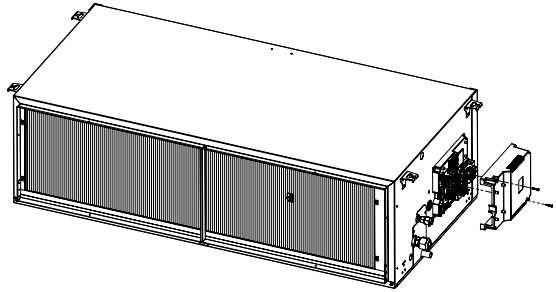
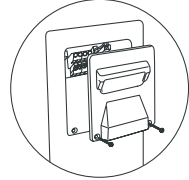
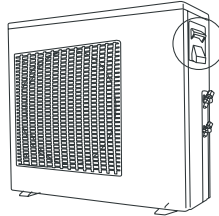

#### 3PH Units Power supply to Outdoor unit

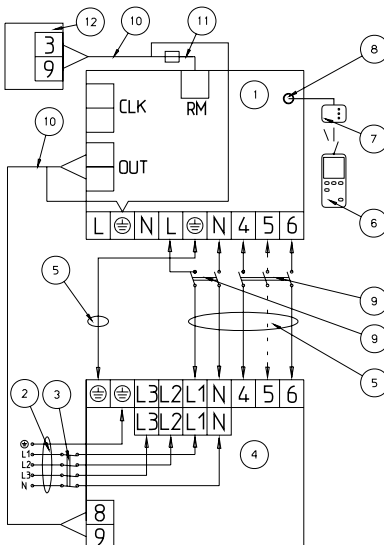

1. Indoor Unit
  2. Power Supply Cable
  3. Main Power Breaker
  4. Outdoor Unit
  5. Interconnecting Cable (6 x 1.5mm<sup>2</sup>)
  6. Wireless Remote Control
  7. Display Unit
  8. Display Connector
  9. Power Breaker\* (by installer)
  10. Control cable\*\*
  11. Sensor Wire with connector
  12. Room Temperature Sensor
- } Optional

\* The power breaker must be of type that disconnected all poles with 3 mm contact opening.

\*\* Use shielded cable and connect the shield to earth point on Indoor Unit only.

## ELECTRICAL CONNECTIONS

### Room Thermostat Installation Instructions - OPTIONAL

Supplied components list

#	Item	QTY
1	Thermostat box	1
2	Shielded cable	2
3	Screws	2
4	Plugs	2

Choosing location of installation:

- Away from air drafts
- Away from direct sun light rays
- Average height – 1.5 meters above floor.
- Away from any heat source

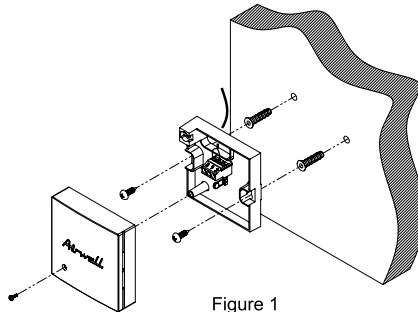

Figure 1

1. Install the thermostat box on the wall according to the above location preferences. See figure 1.
2. Connect the shielded cable supplied to the thermostat box into points 3 and 9 (non polarity).
3. Connect the other end of the cable to the indoor unit main controller into the "RM" extension cable connector. Also connect the grounding fork terminal into the grounding terminal point. See electrical scheme in previous page.
4. **Connect Earth at Indoor Unit only.**

### Control cable (Outdoor coil thermistor) Installation Instructions

1. Use the shielded cable and cut the terminal connector while leaving 25mm of the wires ending.
2. Strip 7 mm of both wires.
3. Connect the wires ending into points 8 and 9 in the outdoor unit electrical terminals (non polarity).
4. Connect the other end of the cable to the indoor unit main controller into the "OUT" connector. Also connect the grounding fork terminal into the grounding terminal point. See electrical scheme in previous page.
5. **Connect Earth at Indoor Unit only.**

## DISPLAY CONTROL UNIT

### LOCATION CRITERIA

It is recommended to install the Display Control Unit close to a ceiling in a central and neutral zone at typical conditions. In addition, the aesthetic aspect should be considered. The Display Control Unit is connected to the main control board on the air conditioner (the indoor unit) by a communication cable. The cable is connected to the Display Control Unit by a quick-connector. (8 pin plug)

### INSTALLATION OF DISPLAY CONTROL UNIT ON WALL

Drill a 12 mm diameter hole on the wall, for routing the communication cable

Open the unit cover, drill 3 holes in the wall to match the holes in the Display Control Unit, install the inserts and fasten the unit to the wall with 3 screws.

The Display Control Unit is provided of a special communication cable, 7 meters long, terminated by a plug, connected in the housing itself to a distribution box, which enables the control of the air conditioner from several different rooms, each one from its own Display Control Unit.

Connect the quick connector to the appropriate socket on the main control board in the indoor unit electrical box.



### WARNING

The plug should not be cut off the communication cable if the cable length is insufficient. In such case, a 5-meter extension cable may be added.

### CONSIDERATIONS IN LOCATING THE REMOTE CONTROL UNIT

- Locate the Remote Control Unit in such a way that when mounted on its support on the wall, it will be in line sight with the Display Control Unit (at less than 8 m).
- It is recommended to establish the final location of the Remote Control Unit only after the first operation, assuring proper transmission and reception between the Remote Control Unit and the Display Control Unit.

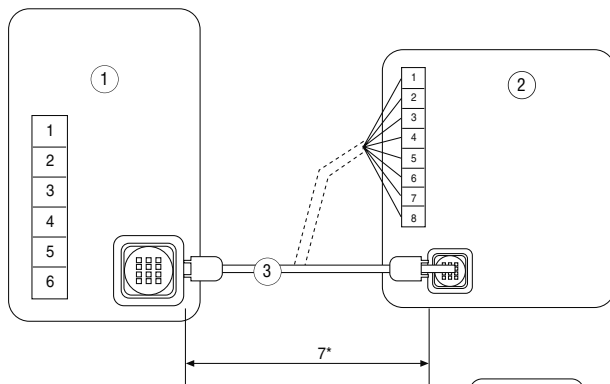

### COLOR CHART

Conn. Point	Wire Color
1	Gold
2	Green
3	Black
4	Brown
5	Purple
6	Yellow
7	Orange
8	Red

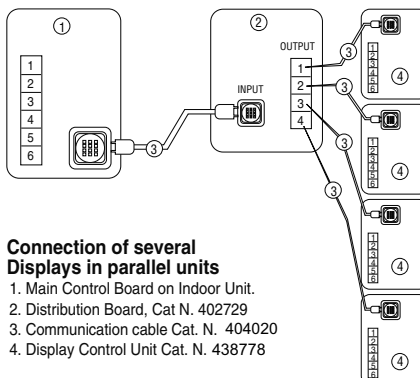

### Connection of several Displays in parallel units

- Main Control Board on Indoor Unit.
- Distribution Board, Cat N. 402729
- Communication cable Cat. N. 404020
- Display Control Unit Cat. N. 438778

# Check list before operation

## CHECK THE DRAINAGE

Pour water into the drain tray-styrofoam.  
Ensure that water flows out from drain hose of the indoor unit.

## EVALUATION OF THE PERFORMANCE

Operate the unit at cooling mode and high fan speed for fifteen minutes or more.

Measure the temperature of the intake and discharge air.  
Ensure the difference between the intake temperature and the discharge is more than 8 °C.

## CHECK ITEMS

- |  |   |
|--|---|
| <input type="checkbox"/> Is there any gas leakage at flare nut connections?                | <input type="checkbox"/> Is the indoor unit properly mounted to the ceiling?    |
| <input type="checkbox"/> Has the heat insulation been carried out at flare nut connection? | <input type="checkbox"/> Is the power supply voltage complied with rated value? |
| <input type="checkbox"/> Is the connecting cable being fixed to terminal board firmly?     | <input type="checkbox"/> Is there any abnormal sound?                           |
| <input type="checkbox"/> Is the connecting cable being clamped firmly?                     | <input type="checkbox"/> Is the cooling operation normal?                       |
| <input type="checkbox"/> Is the drainage OK?<br>(Refer to "Check the drainage" section)    | <input type="checkbox"/> Is the thermostat operation normal?                    |
| <input type="checkbox"/> Is the earth wire connection properly done?                       | <input type="checkbox"/> Is the remote control's LCD operation normal?          |

## CARE AND MAINTENANCE



### Caution!

Before any maintenance operation the unit should be disconnected from mains.

## DISPLAY CLEANING

- Clean the unit with a dry, soft cloth
- Don't use warm water or solvents, in order to avoid damage to the external surfaces.

## BEFORE OPERATING SEASON

- Make sure that no object obstacles return and exiting air flow, in both internal and external units.
- Make sure that the air conditioner is properly connected to mains.
- Remember that power is supplied to the external unit through the internal unit.

## PROTECTION FOR THE ELECTRONIC SYSTEM

- The distance between remote control unit and any electrical appliance should be at least 1 m.

## AIR VOLUME / STATIC PRESSURE

Static pr. (Pa)	80	90	100	110	120	130	140	150	160	170	180	190	200
Air Volume	M <sup>3</sup> /Hr	M <sup>3</sup> /Hr	M <sup>3</sup> /Hr	M <sup>3</sup> /Hr	M <sup>3</sup> /Hr	M <sup>3</sup> /Hr	M <sup>3</sup> /Hr	M <sup>3</sup> /Hr	M <sup>3</sup> /Hr	M <sup>3</sup> /Hr	M <sup>3</sup> /Hr	M <sup>3</sup> /Hr	M <sup>3</sup> /Hr
High							3265	3170	3075	2993	2910	2835	2760
Med					3070	2978	2885	2835	2785	2670	2555		
Low	2430	2368	2305	2228	2150								

Non working range area

## AIR FILTER ACCESS

Turn off two screws and release a air filter support.

Pull down the air filter for further treatment.

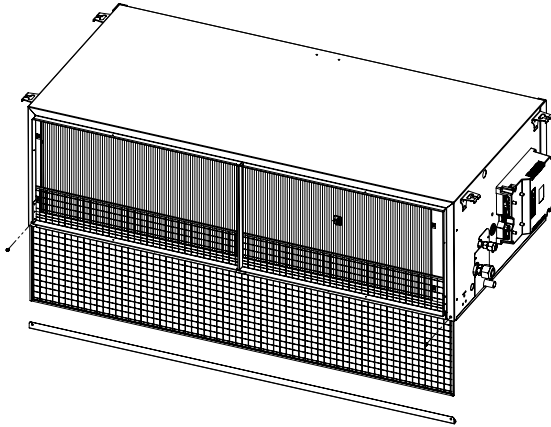

### Caution!

The Air Conditioner should not be activated without air filters mounted in place!