

MULTISPLITS

WMT 090914 RC

HIGH TECH



WMN9 - WMN12
WMZ9 - WMZ12



PXD9 - PXD12



ECF9 - ECF11



WMF9 - WMF12



LS11

English

Français

Deutsch

Italiano

Espanol



7.06kW



7.50kW

SIMULTANEOUS COOLING - HEATING
FROID – CHAUD SIMULTANE
GLEICHZEITIGER HEIZ UND KÜHLBETRIEB
FREDDO – CALDO SIMULTANEI
FRÍO – CALOR SIMULTÁNEO



IOM TRIO 01-EL-1ALL

Part number / Code / Code / Codice / Código : 3990216

Supersedes / Annule et remplace / annulliert und ersetzt /

Annulla e sostituisce / anula y sustituye : None / Néant / Nicht / Nulla / Ninguno



INSTALLATION INSTRUCTIONS

NOTICE D'INSTALLATION

INSTALLATIONSHANDBUCH

ISTRUZIONI INSTALLAZIONE

INSTRUCCIONES DE INSTALACIÓN

English

Français

Deutsch

Italiano

Español

CONTENTS

GENERAL RECOMMENDATIONS	3
SAFETY ADVICE	3
WARNING	3
PACKAGE CONTENTS	4
ACCESSORIES	4
GENERAL	4
CHARACTERISTICS	4
CONFIGURATION POSSIBILITIES	5
OUTDOORS UNIT – DESCRIPTION	6
DIMENSIONS	7
HANDLING PROCEDURE	8
TECHNICAL SPECIFICATIONS	8
ELECTRICAL SPECIFICATIONS	9
REFRIGERATING SPECIFICATIONS	10
WMT 090914 RC INSTALLATION	11
GROUND ATTACHMENT	11
CONDENSATE EVACUATION – DRAIN POSITIONING	11
DISTANCES AND LEVEL DIFFERENCES BETWEEN ST AND WMT 090914 RC	12
PIPE CONNECTIONS	13
REFRIGERATION PIPE CONNECTIONS BETWEEN WMT 090914 RC AND ST	13
PIPE WORK TO BE PRODUCED ON SITE	13
REFRIGERATING PIPE CONNECTIONS/LIAISONS FRIGORIFIQUES	13
REFRIGERATING PIPE CONNECTIONS BETWEEN THE INDOORS UNITS AND THE OUTDOORS UNIT	14
EXAMPLE OF CONNECTION REQUIRING ADDITION OF R407C REFRIGERANT	15
VACUUM DRAINING THE INDOORS UNIT AND THE REFRIGERATING PIPES	16
VACUUM DRAINING PROCEDURE	16
WIRING DIAGRAM AND LEGEND	17
ELECTRICAL CONNECTIONS	19
INDOORS UNITS:	19
OUTDOORS UNIT:	19
INDOORS UNITS INSTALLATION	20
SCHEMATIC DIAGRAM - WMT 090914 RC WITH ST AND WITHOUT ELECTRICAL HEATING	21
SCHEMATIC DIAGRAM - WMT 090914 RC WITH ST- WITH ELECTRICAL HEATING	22
FUSE HOLDER CONNECTION DETAILS ON MODEL WITH ELECTRICAL HEATING	23
REGULATION SYSTEM	24
GENERAL OPERATING PRINCIPLES	24
SAFETY PROTECTION	24
DE-ICING	24
CHECKS BEFORE STARTING	25
POWER SUPPLY	25
ELECTRICAL TUBING	25
CONDENSATES DRAINAGE	25
REFRIGERANT CONNECTIONS	25
CONNECTIONS THROUGH A WALL	25
ATTACHMENT	25
FINAL TASKS	25
MAINTENANCE AND SERVICING	26



**POWER SUPPLY MUST BE
CUT OFF BEFORE
STARTING ANY WORK ON
THE ELECTRICAL BOXES**

GENERAL RECOMMENDATIONS

Firstly, congratulations for having selected an **ELECTRA** air conditioner.

SAFETY ADVICE

Always follow current safety regulations when working on your equipment.

Only qualified personnel should perform equipment installation and maintenance.

Make sure that the electrical voltage and frequency are adapted to the required operating power supply, taking account of the specific installation conditions and the power required by any other appliance connected on the same circuit.

WARNING

The power supply must be cut off before starting any work or maintenance operation.

The manufacturer declines all liability, and the guarantee becomes void, in the event of non-compliance with these installation instructions.

In case of difficulties, please contact your local Technical Department.

If possible, assemble the mandatory or optional accessories before placing the appliance on its final location (refer to the instructions provided with each accessory).

The information contained in these instructions is subject to change without prior notice.

This appliance complies with **EC STANDARDS**.

PACKAGE CONTENTS

- 1 WMT 090914 RC outdoors unit
- 4 rubber pads
- 1 bag of fasteners
- 1 shunts (model with electrical heating)
- 10 cable ties
- 1 drain + seal
- 3 connectors
- 1 identification label for the wiring and pipe connections between the indoors unit and the WMT 090914 RC
- 1 bag of documentation

ACCESSORIES

Wall bracket

1/2"-1/4" Flare connectors

3/8"-1/4" Flare connectors

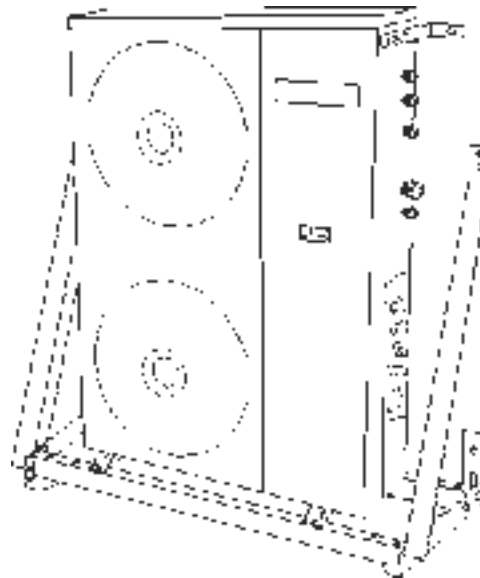

GENERAL

CHARACTERISTICS

The outdoors reversible unit (WMT 090914 RC) comprises:

2 independent refrigerating circuits

1 unit per circuit A and 2 units per circuit B

Rotary compressor

Microprocessor control

It is compatible with Comfort range indoors units

CONFIGURATION POSSIBILITIES

The difference in capacities between the two circuits added to the broad variety of installation configurations mean that «Made to measure» air conditioning installations, perfectly adapted to each application, can be created.



WMN9 - WMN 12
WMZ9 - WMZ12



PXD9 - PXD12



ECF9 - ECF11



WMF9 - WMF 12



LS11

OUTDOORS UNIT – DESCRIPTION

One of the WMT 090914 RC HIGH TECH's advantages is its compact design, taking up very little floor space. Each circuit comprises:

DESCRIPTION	REP.	UNIT	
		A	B
Rotary compressor	1	1	1
Axial fan (dual speed)	2	1	1
Main exchanger	3	1	1
Auxiliary exchanger for optimising operation under partial load conditions	4		1
3/8" solenoid valves for controlling the following modes: Each ST unit's Unoccupied or Standby mode	5		2
One 1/4" solenoid valve for discharging refrigerant into the auxiliary exchange A single ST in operation	6		1
4 way valves for thermodynamic heating	7	1	2
Temperature sensors			
OAT (Outdoors Air Temperature)		1	1
OCT (Outdoors Coil Temperature)		1	2

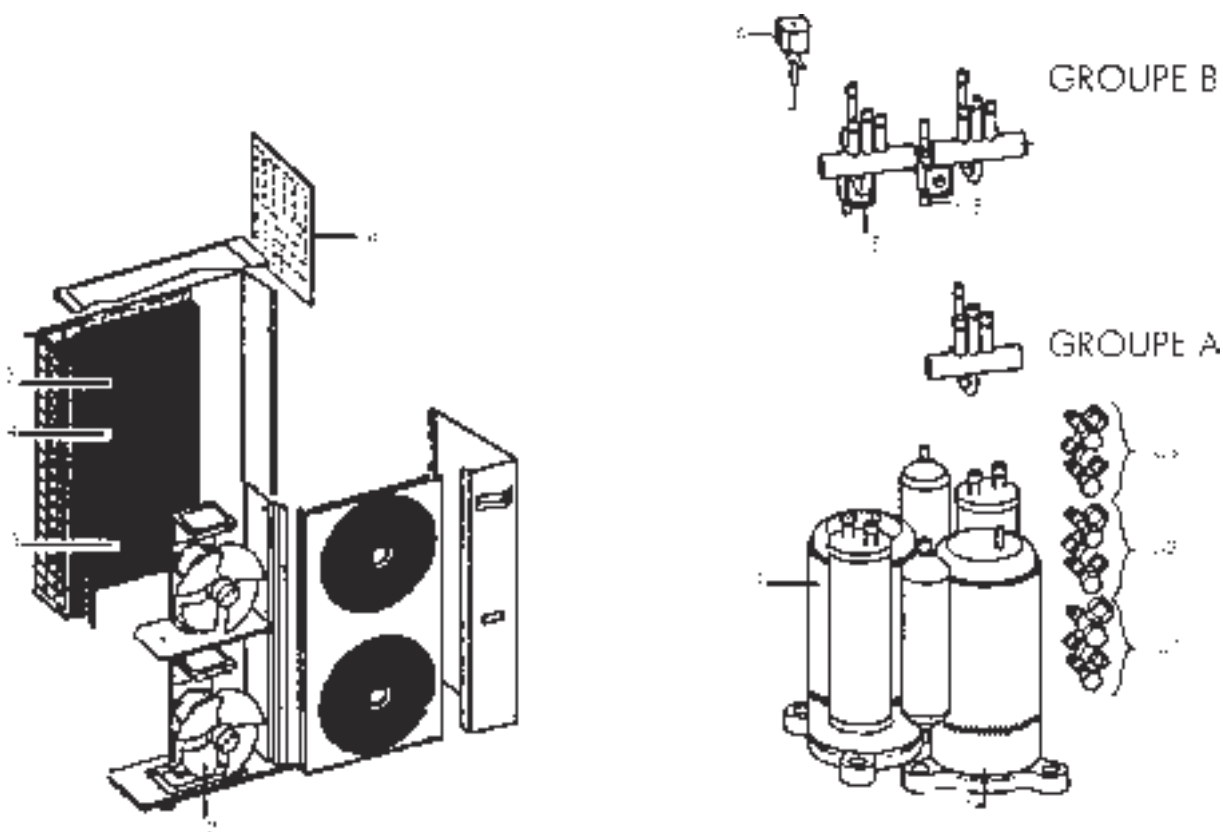

A regulator in the electrical box automatically manages the functions of the entire installation in accordance with the demands expressed by the indoors units.(8)

DIMENSIONS

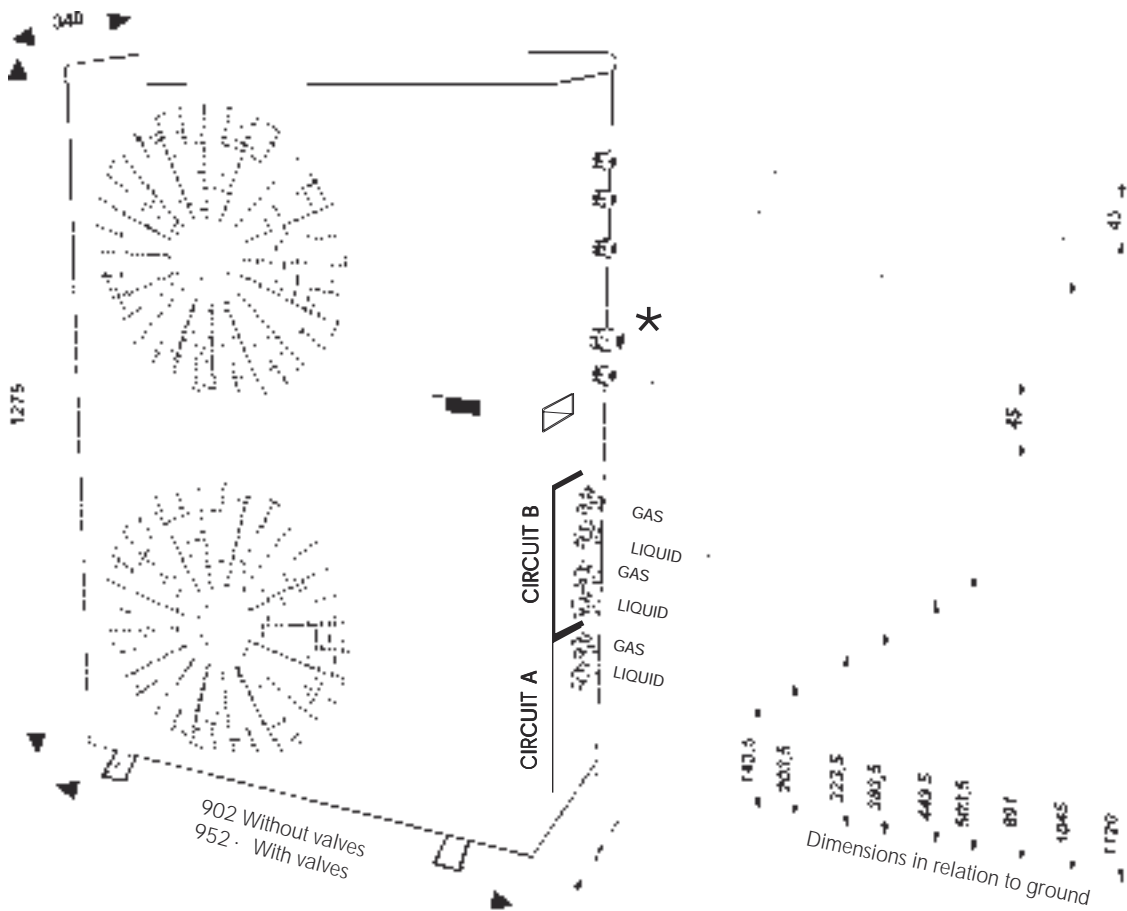
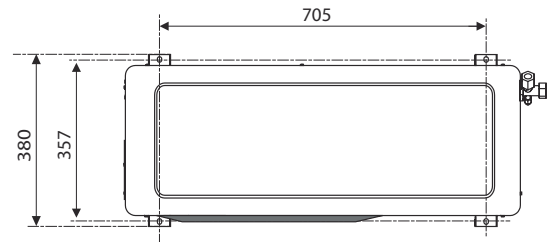
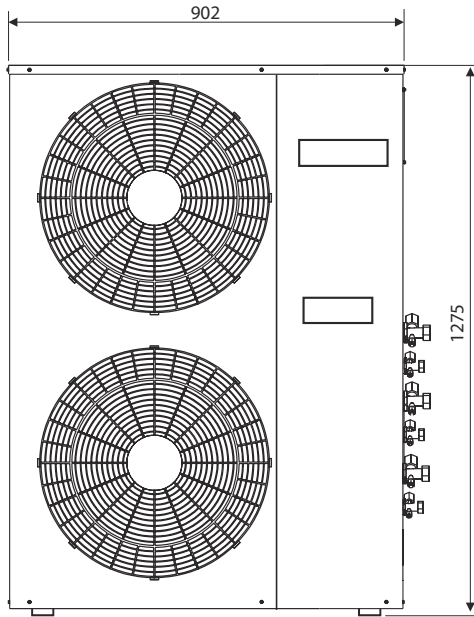

*

2 packing boxes for the mains power supply.

2 different sizes: installer to choose size in relation to mains power supply cable section (ST with or without electrical heating).

HANDLING PROCEDURE



113 kg Net weight

124 Kg Packed weight

Centre of gravity

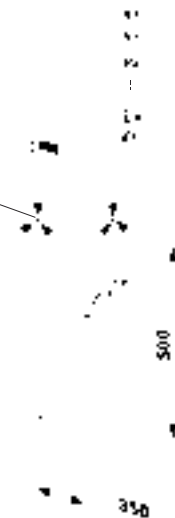

TECHNICAL SPECIFICATIONS

Model		R407C HEAT PUMP	
CIRCUIT A			
Refrigerant charge (*)		g	757
Connecting pipe	Gas pipe	in (") - mm	1/2" - 12
	Liquid pipe	in (") - mm	1/4" - 6
CIRCUIT B			
Refrigerant charge (*)			1315
Connecting pipe	Gas pipe	in (") - mm	3/8" - 10
	Liquid pipe	in (") - mm	1/4" - 6
Unit operating range			
Cooling mode operating range			
Upper limit		°C	43°C DB
Lower limit		°C	21°C DB
Heating mode operating range			
Upper limit		°C	24°C DB / 18°C WB
Lower limit		°C	-5°C DB / -6°C WB

* The R407C refrigerant charge value is given for 4 m pipe length connections with WMN type outdoors units on both circuits

For any installations with longer pipe lengths, please refer to: § REFRIGERATING SPECIFICATIONS and Example of connection requiring addition of R407c refrigerant

(DB) Dry Bulb temperature

(WB) Wet bulb temperature

ELECTRICAL SPECIFICATIONS

TRIO HEAT PUMP					
		A	B	C	D
Number of ST units without heating		3	2	1	0
Number of ST units with heating		0	1	2	3
	Unité				
Total nominal current	A	12.2	20.7	27.3	33.9
Total maximum current	A	15	23.5	30.1	36.7
Total starting current	A	70	78.5	85.1	91.7
Fuse rating aM/VDE	A	20/20	25/25	32/35	40/50
3G type power supply cable section	mm ²	2,5	6	10	10

ELECTRICAL CONNECTIONS TO ST UNITS

CONFIGURATION EXAMPLE	Unité	A	B	C	D
Max. current / ST w/o elec. heating	A	1 X 1,5	0	0	0
Max current / ST with elec. heating (UNIT A)	A	0	1 X 10,2	1 X 10,2	1 X 10,2
Max. current / ST w/o elec. heating	A	2 X 1,5	2 X 1,5	1 X 1,5	0
Max current / ST with elec. heating (UNIT B)	A	0	0	1 X 6,6	2 X 6,6
Fuse rating with electrical heating aM	A	0	10	10 / 10	10 / 20
6G type ST connecting cable section	mm ²	1,5	1,5	1,5	1,5

UNIT A: FUSE QF1

UNIT B: FUSE QF23

Comments:

This data is given for the most unfavourable installation in terms of maximum current draw: 1 LS11 on circuit A / 2 PXD9 on circuit B

Case with 3 cassettes (2 x ECF9 + 2 x ECF11):

8A fuse is to be provided for unit A

16A fuse is to be provided for unit B .

Electrical heating details for each ST for determining the appropriate fuse rating

Indoors unit type	Electrical heating capacity (W)	Maximum current (A)
PXD 9	1250	6,6
ECF 9	900	4,7
LS 11	1600	8,5
PXD 12	1250	6,6
ECF 11	900	4,7

IMPORTANT

* The installer must comply with all local standards. The cable section must be suitable for the installation method, the type of cable insulation and the cable length.

These values are provided for information purposes only. They must be verified and adapted in relation to existing standards.

These values may vary in relation to the type of installation and the choice of conductors.

REFRIGERATING SPECIFICATIONS

The WMT 090914 RC HIGH TECH comprises 2 independent non-identical circuits.

The unit is factory filled with refrigerant for the following installation configuration:

Circuit A: 1 WMN12/WMZ12 type indoors units and 4 m pipe lengths per way.

Circuit B: 2 WMN9/WMZ9 type indoors units and 4 m pipe lengths per way.

For longer pipe lengths the amount of charge to be added is **15g/m for each way**.

The range of authorised configurations is as follows:

UNIT A - RC	UNIT B - RC
WMN12 / WMZ12	WMN9 / WMZ9 WMN9 / WMZ9
PXD12	WMN9 / WMZ9 PXD9
ECF11	WMN9 / WMZ9 ECF9
WMF12	WMN9 / WMZ9 WMF9
LS11	WMF9 PXD9
	PXD9 PXD9
	ECF9 ECF9
	ECF9 ECF9

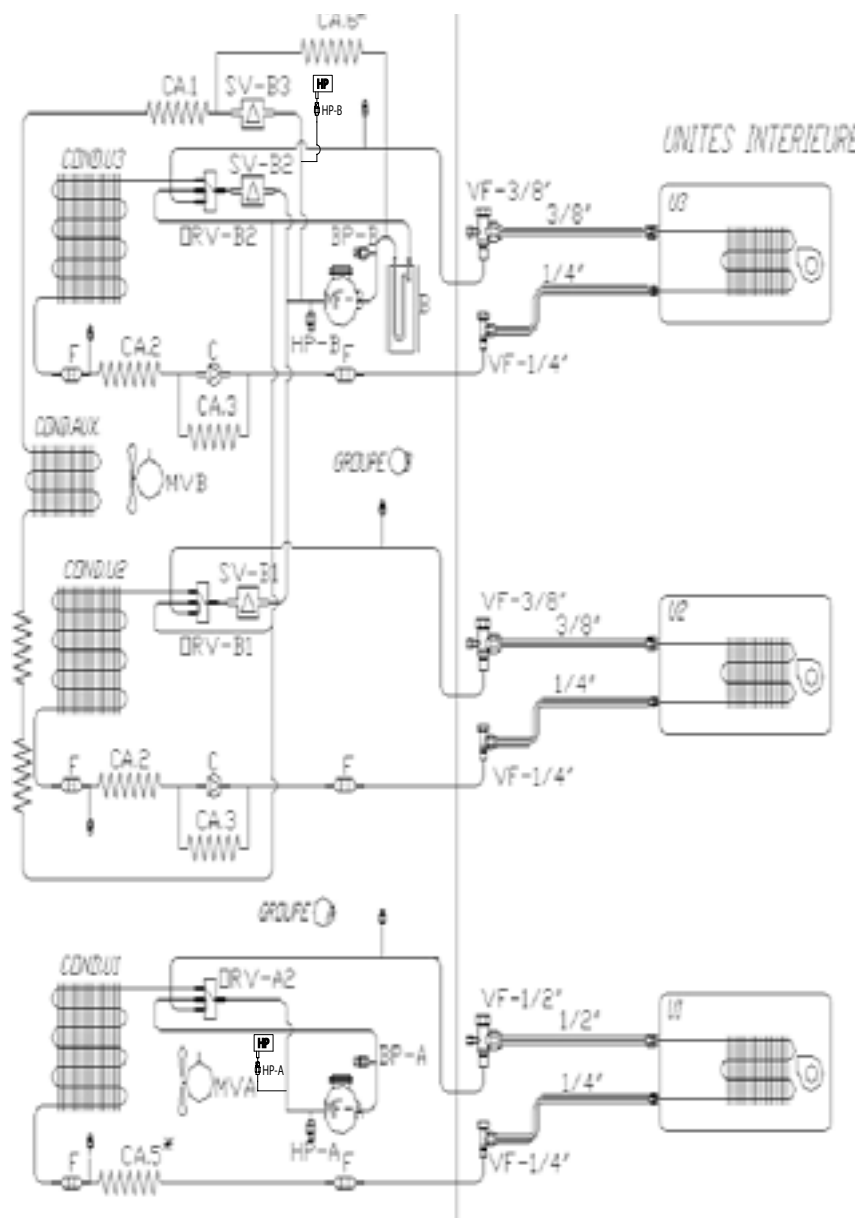

WMT 090914 RC INSTALLATION

Minimum free clearances:

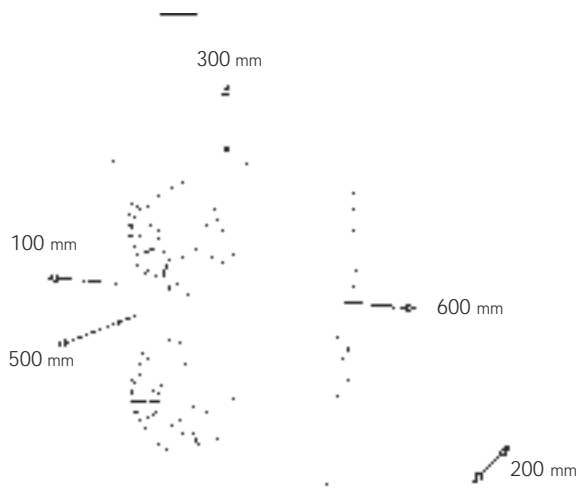

GROUND ATTACHMENT

On concrete slab with rubber pads supplied or PAULSTRA 521571 type vibration absorption pads.

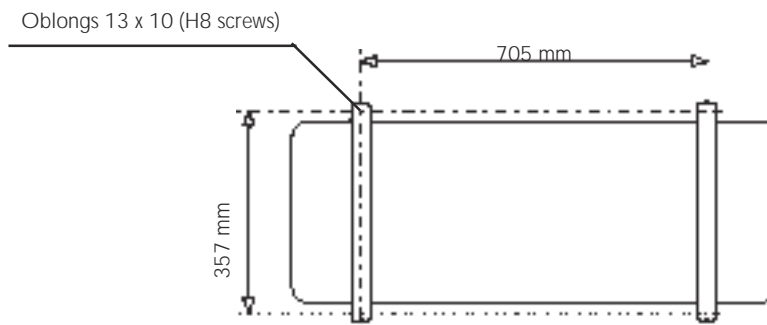

CONDENSATE EVACUATION – DRAIN POSITIONING

To ensure effective condensate drainage, the drain pipe should be routed on a downward slope of 2.5 cm/metre.

Adequate heat insulation for the condensate drain pipe should be provided for harsh climates, or sub-zero temperatures.

Fit the drain pipe and its seal (supplied) if required, BEFORE attaching the unit to the ground.

For Heat pump models, in locations where the outdoors temperature may fall below 1°C, a condensate anti-freezing protection device must be provided (a heated wrap for example).

When installing the unit in harsh climates, sub-zero temperatures, snow, or humidity it is recommended that it is raised about 10 cm above ground level.



DISTANCES AND LEVEL DIFFERENCES BETWEEN ST AND WMT 090914 RC

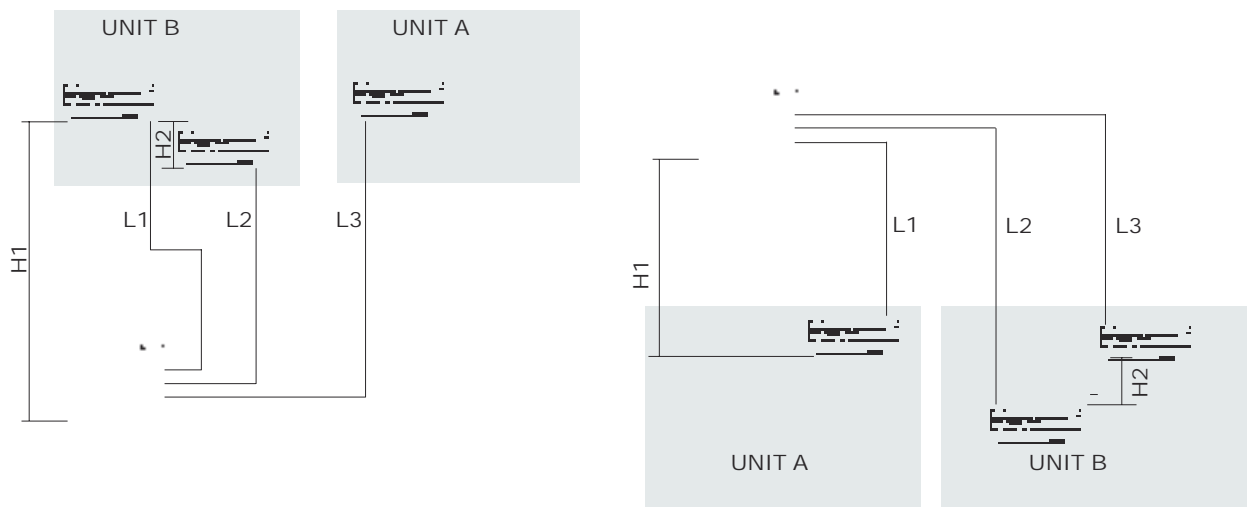

M A X I M U M H E I G H T	
H 1	1 0 m
H 2	5 m

M A X I M U M L E N G T H	
L 1	1 5 m
L 2	
L 3	

Any pipe length of level difference exceeding the values stated in the above table is to be avoided.

PIPE CONNECTIONS

Pipe connections between the GC and the ST units must be performed before undertaking the electrical connections.

REFRIGERATION PIPE CONNECTIONS BETWEEN WMT 090914 RC AND ST

Labels supplied with the WMT 090914 RC unit enable the valves to be marked as the installation operations advance.

The indoors units can be installed in 3 different rooms.

Refrigeration pipe lengths are available as an accessory in fixed lengths of 2.5, 5 and 8m.

The pipe lengths are supplied in rolls. They are insulated and fitted with FLARE nuts.

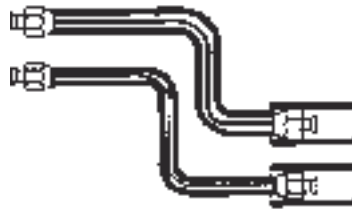

Unroll the pipes carefully, in the opposite direction to the spirals, to avoid bending them.

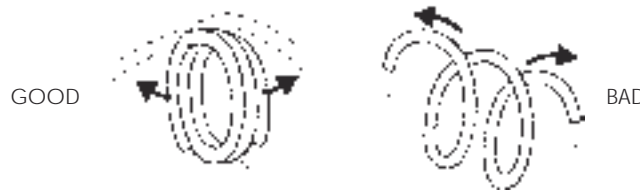

PIPE WORK TO BE PRODUCED ON SITE

This operation must only be performed by qualified personnel, in accordance with refrigeration engineering best practices (brazing, vacuum draining, charge addition, etc...).

REFRIGERATING PIPE CONNECTIONS/LIAISONS FRIGORIFIQUES

The pipe bend radius must be equal to or greater than 3.5 times the outside tube diameter.



REFRIGERATING PIPE CONNECTIONS BETWEEN THE INDOORS UNITS AND THE OUTDOORS UNIT

Indoors units contain a small amount of neutral GAS.

Do not unscrew the nuts on the indoors and outdoors units before being ready to proceed with connecting the refrigerating pipes.

The outdoors unit contains sufficient refrigerant fluid for pipes up to a length of 4 metres per way.

Only use proper pipe bending tools to form the pipe bends in order to avoid any breakages.

To ensure a perfect seal, cover the valve surface with refrigeration oil.



THE USE OF A COUNTER SPANNER IS INDISPENSABLE FOR TIGHTENING THE VALVES.



The tightening torque values are specified in table below:

PIPE Ø	TIGHTENING TORQUE
1/4"	15-20 Nm
3/8"	30-35 Nm
1/2"	50-54 Nm
5/8"	70-75 Nm
7/8"	90-95 Nm

NOTA

Only use «refrigeration engineering» quality, copper piping and **designed for withstanding pressures at least equal to 30 bars**

Use pipe with the appropriate Ø for each model. (Refer to pipe dimensions and tightening torque values table above).

Insulate each pipe as well as its connectors separately, with insulation material having a minimum thickness of 6mm.

Attach the refrigerating pipes, the condensate drain pipe and the electrical cable together with a strap.

Place the FLARE nuts on the pipe ends and prepare them with a pipe end flaring tool.

Use the FLARE nuts fitted to the indoors and outdoors units.

Connect the four ends of the two pipes to the indoors and outdoors units.

Repeat these operations for connecting the 2nd, 3rd and 4th indoors units

EXAMPLE OF CONNECTION REQUIRING ADDITION OF R407C REFRIGERANT

NOTA:

The R407C refrigerant charge value is given for 4 m pipe length .

For longer pipe lengths the amount of charge to be added is **15g/m for each way**

CIRCUIT A (U1-A)

The additional quantity of R407C will be:

+ 165 g (15m pipe lengths)

being, in this example, an increase of 255 g for circuit A,
and

CIRCUIT B (U2-B / U3-B)

+ 165 g (15 m pipe lengths)

+ 15 g (5 m pipe lengths)

being, in this example, an increase of 180 g for circuit B,

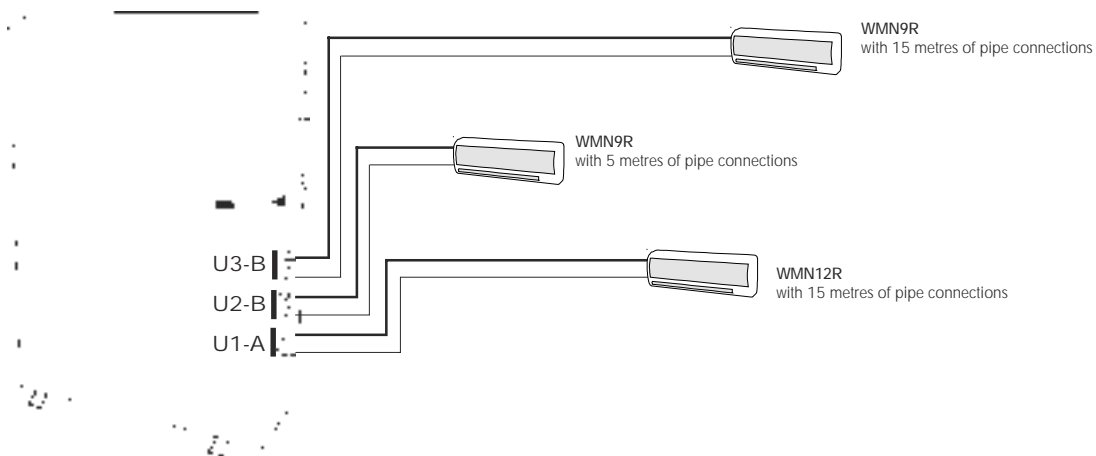

NOTA :

This operation must only be performed by qualified personnel, in accordance with refrigeration engineering best practices.

The values in the example of connection for these pipe lengths require the addition of R407C refrigerant on site. Any interventions on the refrigeration circuits must be performed in strict compliance with CECOMAF GT1-001 recommendations (recommendations on R407C emissions into the atmosphere).

VACUUM DRAINING THE INDOORS UNIT AND THE REFRIGERATING PIPES

The R407C charge is only contained in the outdoors unit.

The indoor unit contains a small quantity of neutral GAS. For this reason, after having installed the pipe connections, it is imperative to proceed with vacuum draining the connections and the indoor unit.

VACUUM DRAINING PROCEDURE

The outdoors unit has a valve provided for the installation to be vacuum drained (large valve).

1. Connect the refrigerating pipes between the indoors and the outdoors units.
2. Connect the vacuum pump to the FLARE connector of the outdoor unit equipped with the service valve (large connector).
3. Start the vacuum pump and check that the vacuum gauge drops to -0.1Mpa (-76cm Hg). The pump should be run for at least 15 minutes.
4. Before removing the vacuum pump, you must check that the vacuum gauge remains stable for 5 minutes.
5. Disconnect the vacuum pump and close the service valve.
6. Remove the cap from the «GAS» and LIQUID» valves and open them with a hexagonal spanner, in order to release the R407C refrigerant fluid contained in the outdoor unit.
7. In the case where the refrigerant pipe connection of one way is longer than 4 m. add an additional charge in accordance with the values stated in Table N° 1.
8. Check the seal on all the connections. Use an electronic leakage detector or a soapy sponge.
9. Repeat these operations for connecting the 2nd, 3rd indoors units.

WIRING DIAGRAM AND LEGEND

LES CORDONS SECTEUR DES UNITES INTERIEURS DOIVENT ETRE DEPOSES
THE POWER CABLES OF THE INTERNAL UNITS MUST BE REMOVED
DIE NETZKABEL DER INNEENHEITEN MUSSEN DEMONTIERT WERDEN
DEBEN DESMONTARSE LOS CABLES DE LAS UNIDADES INTERIORES
PRIMA DI ESEGUIRE QUALSIASI OPERAZIONE TOGLIERE
I CORDINI DI ALIMENTAZIONE

GC MULTISPLITS 3 VOIES REVERSIBLE
3 WAYS GC MULTISPLITS REVERSE CYCLE
GC MULTI-SPLITS 3 VIAS REVERSIBLE
3 WEGEN GC WARPUMPMULTI-SPLITS
GC MULTISPLITS 3 VIE REVERSIBILE
230V ~ 50 Hz + ⚡

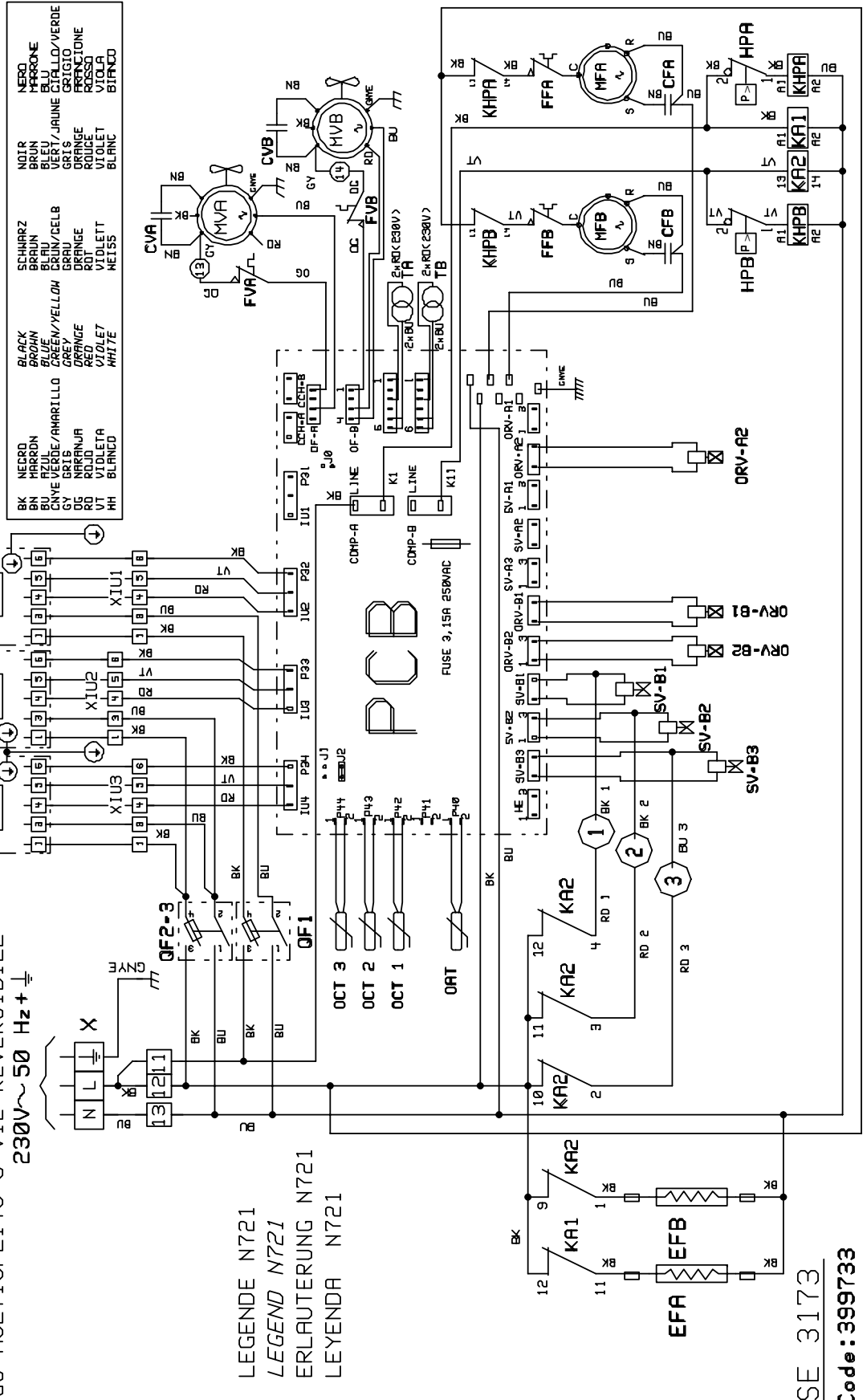

NERO	SCHWARZ	BLACK	NERO
MARRONE	BRUN	BROWN	MARRONE
BLU	VERT / JAUNE	BLUE	BLU
CIALLO/VERDE	GRIS	GREEN/YELLOW	CIALLO/VERDE
GRIGIO	GRAU	GRAY	GRIGIO
ROSSO	ROUGE	RED	ROSSO
ROSSO/NERO	ROUGE/NOIR	RED/BLACK	ROSSO/NERO
VIOLA	VIOLET	VIOLET	VIOLA
BIANCO	BLANC	WHITE	BIANCO

LEGENDE N721
LEGEND N721
ERLAUTERUNG N721
LEYENDA N721

SE 3173
Code: 399733

WIRING DIAGRAM LEGEND SE 3172/3173
CODE: 399734

MFA/MFB	COMPRESOR
FFA/FFB	EXTERNAL PROTECTION MFA/B
CFA/CFB CVA/CVB	CAPACITOR
EFA/EFB	CRANKCASE HEATER
PCB	ELECTRONIC CONTROLL-BOARD
TA/TB	TRANSFORMER 230/12V
OCT1...OCT4	DEFROSTING SENSOR
OAT	AMBIENCE SENSOR
SV-A1...SV-B3 / SVA3 A..B	SOLENOID VALVE
ORV-A1...ORV-B2	REVERSING VALVE
J1/J2/J0	JUMPER
R1...R4	DUMMY PROBE
HPA/HPB	AUTOMATIC HIGH PRESSURE PRESSOSTAT
KA1/KA2/ KA3/KA4 KHPA/KHPB	RELAY
MVA/MVB	MOTEUR CONDENSING FAN MOTOR
FVA/FVB	INTERNAL PROTECTION OF MV A/B
XIU1...XIU4	INDOOR UNIT TERMINAL
X	MAIN TERMINAL STRIP
QF 1-2/3-4 QF 1/2-3	HEATER FUSE SWITCH (NOT FITTED)

ELECTRICAL CONNECTIONS

INDOORS UNITS:

Do not take account of the electrical connections instructions contained in the indoors units Installation Instructions.

OUTDOORS UNIT:

On the WMT 090914 RC, remove the front panel (Fig. below. Ref. **A** - 5 screws).

Connection to the mains power supply is via the WMT 090914 RC unit.

Mains cable not supplied. (Refer to electrical specifications).

- Pass the cable into the stuffing box (fitted to the unit).
- Block the stuffing box in position.
- Connect this cable to the X terminal block X (Refer to the schematic diagram)

Connecting cable to the indoors units from the WMT 090914 RC not supplied. (Refer to electrical specifications).

- Pass the cables into the corresponding stuffing boxes (fitted to the unit).
- Block the stuffing boxes in position.
- Connect the cable to the corresponding terminal blocks: U1A - U2B - U3B.

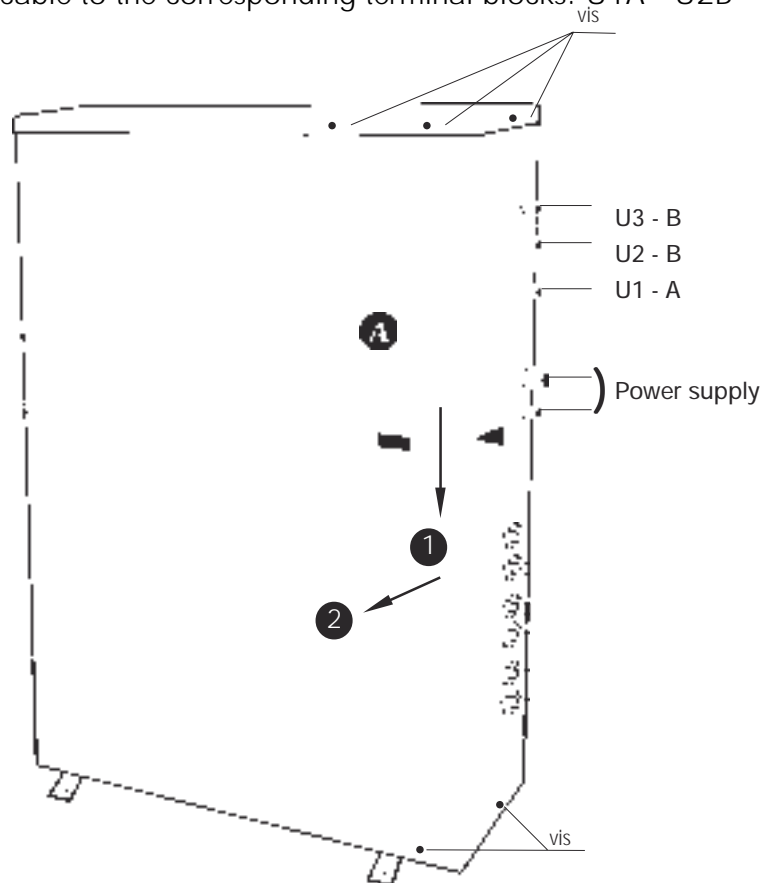

INDOORS UNITS INSTALLATION

For setting up the ST units, refer to the Installation Instructions provided with these indoors units.

**WMF, WMN and WMZ
ALWAYS DISCONNECT THE POWER CABLE
HARNESSES BEFORE STARTING ANY WORK**

SCHEMATIC DIAGRAM - WMT 090914 RC WITH ST AND WITHOUT ELECTRICAL HEATING

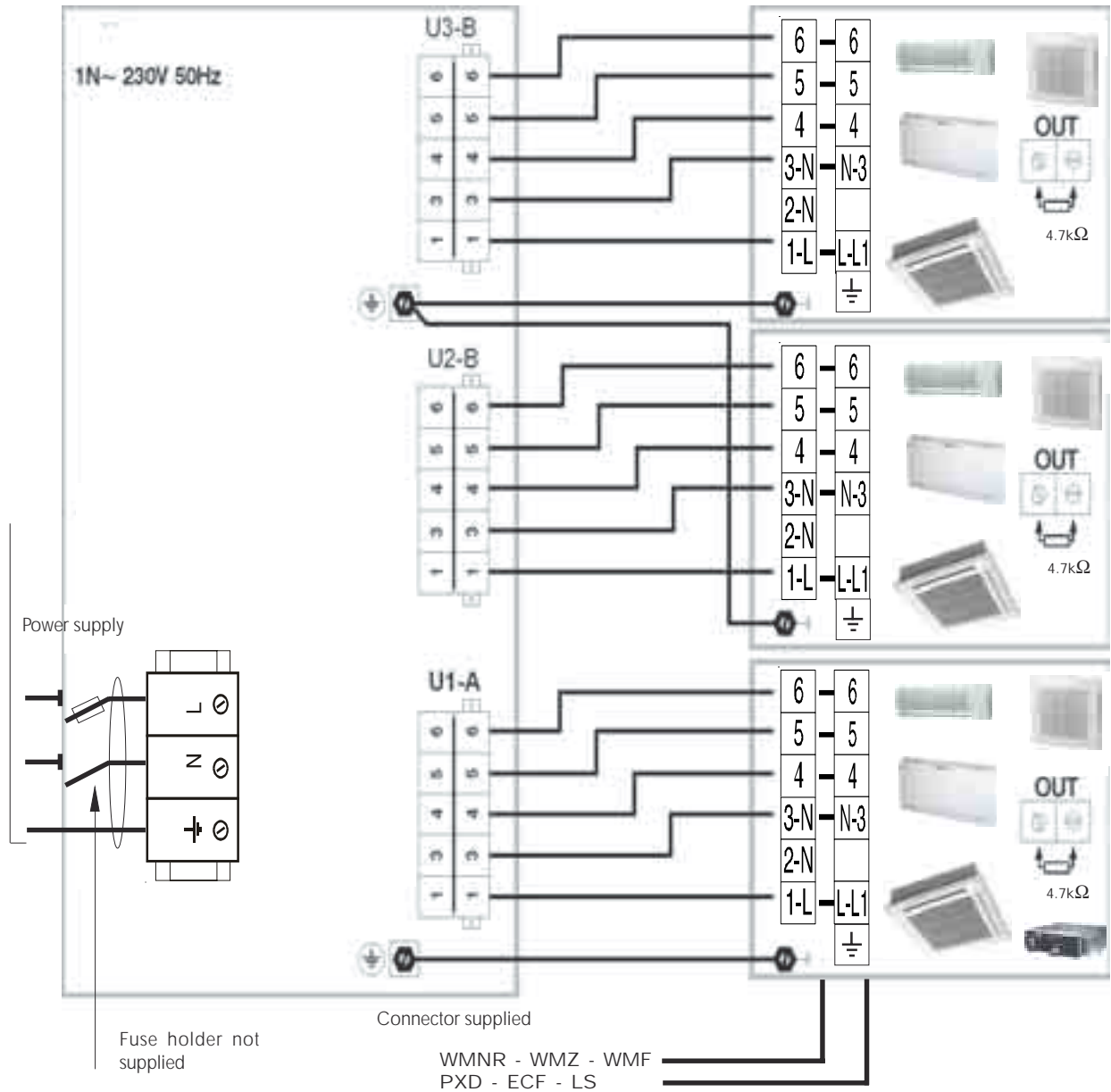

SCHEMATIC DIAGRAM - WMT 090914 RC WITH ST- WITH ELECTRICAL HEATING

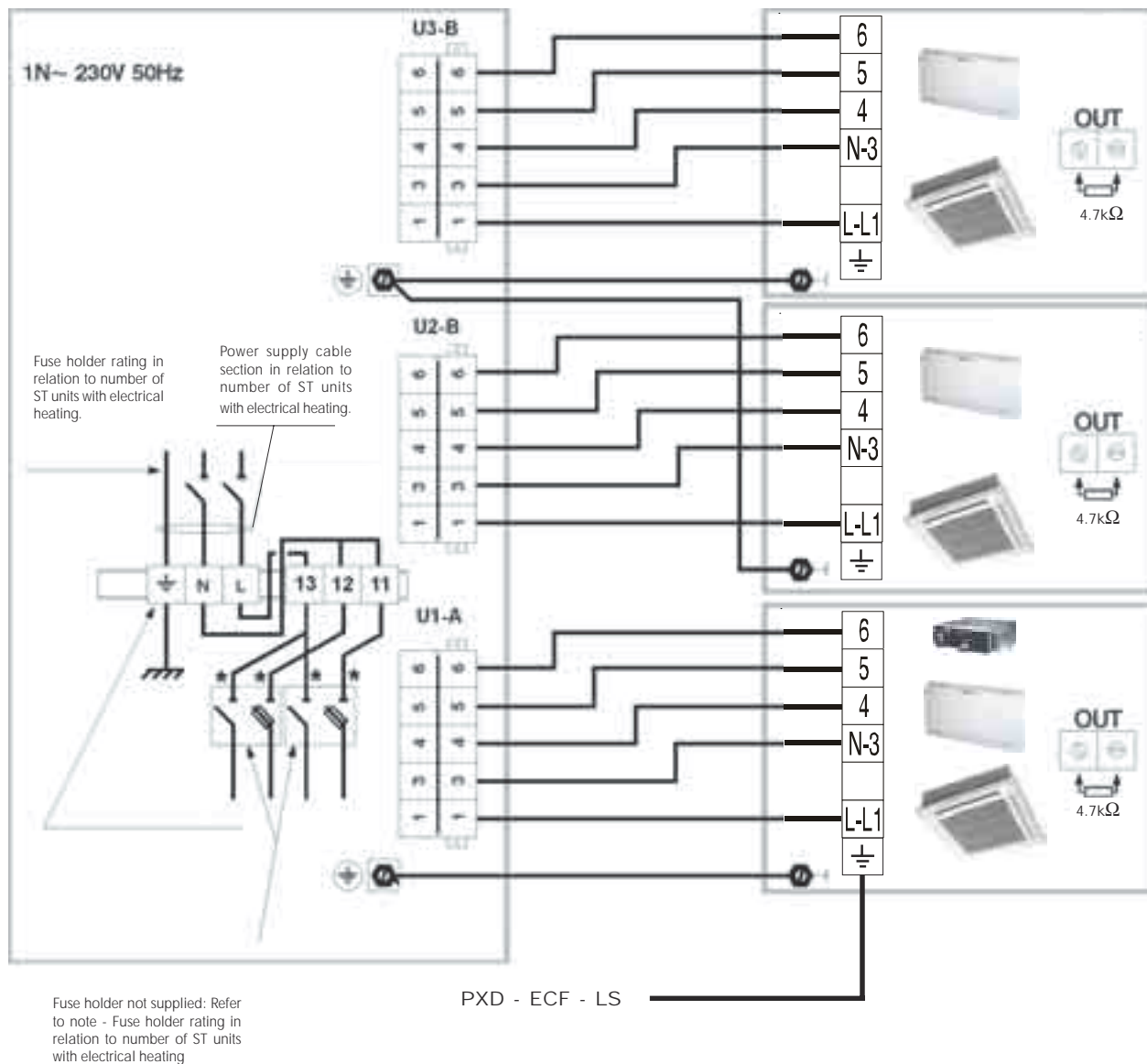

* Wires supplied

NOTA :

If 2 or more indoors units are equipped with electrical heating, the installation of one or two single pole fuse holders with a neutral cut out (17.5 mm module – not supplied) is required.

Location and connection of fuse holders (not supplied) with the shunts supplied.

FUSE HOLDER CONNECTION DETAILS ON MODEL WITH ELECTRICAL HEATING

1 BEFORE INTEGRATION OF THE FUSE HOLDER

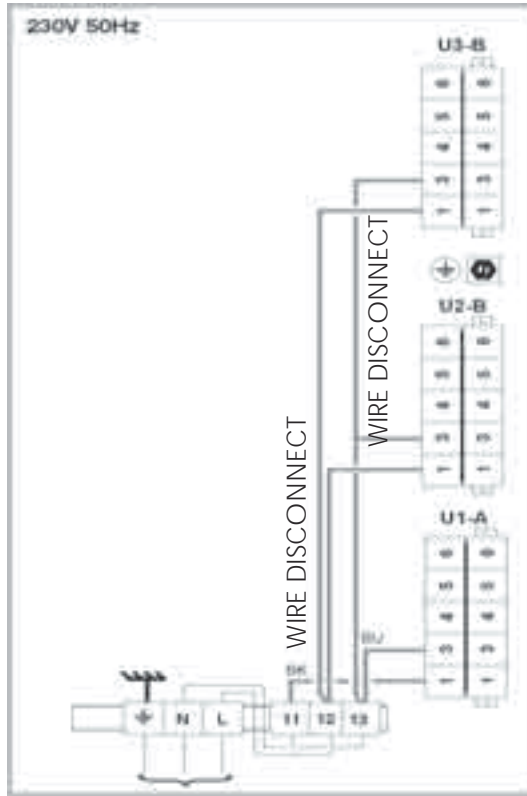

2 AFTER INTEGRATION OF THE FUSE HOLDER (wiring harness supplied)

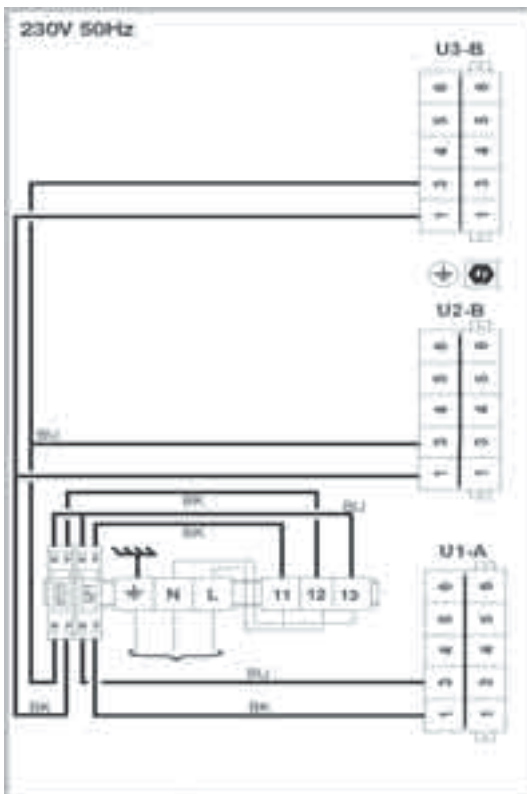

REGULATION SYSTEM

GENERAL OPERATING PRINCIPLES

The regulation PCB input data is directly linked to the demands expressed by the indoors units (demands for compressor, fan, 4 ways valve). These inputs, associated with an outdoors sensor, provide a truth table translating the unit's operating characteristics in each mode.

Fan

The fan operation is linked directly to the outdoors temperature.

The values for passing from Low Speed to High Speed are determined by the operating mode.

Compressor

The regulation system includes anti-short cycle protection for the compressor to avoid excessive start/stop actions than could damage its operation.

SAFETY PROTECTION

The machine is protected against any malfunctions by 2 levels of HP protection.

A first level of protection by an automatic reset safety protecting the machine when the condensing temperature has exceeded the set threshold.

A second level of protection by a manual reset safety activated when the condensing pressure is higher than the threshold set by the safety pressostat.

It is important to check the quantity of the refrigerant charge in the system if these protection devices are activated repeatedly.

The HP protection is only activated for the unit A or B in question. The other circuit will continue to operate normally.

DE-ICING

The regulation system provides automatic control of the de-icing function for the outdoors exchanger in relation to outdoors temperature conditions

When one of the units triggers the demand for de-icing, the entire system (units A and B) is de-iced simultaneously.

CHECKS BEFORE STARTING

POWER SUPPLY

The electrical supply voltage and frequency must comply with the values stated on the Maker's Plates on both the indoors and outdoors units.

ELECTRICAL TUBING

The units are designed connected as a fixture to fixed electric tubing. Do not use removable plugs or flex for the power cable or the connection cables between the indoors and outdoors units.

CONDENSATES DRAINAGE

Check that water drains properly by pouring a quantity into the indoors unit condensate tray. Check that all connections are watertight and, as required, protect the pipe work with insulation material if there is a risk of freezing or of condensation.

REFRIGERANT CONNECTIONS

Using an appropriate detection device, check the tightness of all refrigerant connections, notably around the connecting valves of the outdoors unit. Check that all pipe work is properly insulated.

CONNECTIONS THROUGH A WALL

Check the seal of the passage hole through a wall where connections pass outside the building. Check that there is no direct contact between the connection tube and the wall surface.

ATTACHMENT

Check that the outdoors and indoors units are attached securely. Refit any previously removed items

FINAL TASKS

Replace the caps on the valves and check that they are properly tightened.

Attach the cables and connections to the wall with clamps as required.

Run the air conditioning system in the client's presence and explain all its functions.

Demonstrate the method of removing, cleaning and refitting the filters.

MAINTENANCE AND SERVICING

All the units are factory-filled with a predetermined R407C charge.

R407C is a mixture of three refrigerant fluids: R32 (23%), R125 (25%) and R134a (52%).

As opposed to R22 that is a pure fluid, R407C is a non-azeotropic fluid. One of the consequences of using R407C is the glide causing temperature variations during the phase of changing from the liquid to the vapour state.

HOW TO IDENTIFY A REFRIGERANT FLUID LEAK?

There may be a refrigerant leak in the system if the following conditions occur with the two indoors units in operation:

Overheating higher than 15°C.

Compressor output temperature higher than 105°C.

Under-cooling lower than 3°C.

In the event of a leak:

Identify the source of the leak.

Completely drain the circuit by forcing the opening of the solenoid valves

Repair the cause of the leak.

Charge the circuit with nitrogen at a pressure of 2 bars and pass soapy water over the pipe work to check that the leak has been properly repaired.

Vacuum drain the circuit down to 10^{-2} bars.

Charge with R407C refrigerant as indicated on the Maker's plate, taking account of the installation's pipe lengths.

CONDENSER

It is recommended that the finned exchanger is checked on a regular basis.

Use a neutral pH cleaning product to avoid any corrosion.

The cleaning operation must be performed with a low pressure water jet to avoid damaging the fins.

CE Compliance declaration

Under our own responsibility, we declare that the product designated in this manual comply with the provisions of the EEC directives listed hereafter and with the national legislation into which these directives have been transposed.

Déclaration CE de conformité

Nous déclarons sous notre responsabilité que les produits désignés dans la présente notice sont conformes aux dispositions des directives CEE énoncées ci- après et aux législations nationales les transposant.

EG-Konformitätserklärung

Wir erklären in eigener Verantwortung, das die in der vorliegenden Beschreibung angegebenen Produkte den Bestimmungen der nachstehend erwähnten EG-Richtlinien und den nationalen Gesetzesvorschriften entsprechen, in denen diese Richtlinien umgesetzt sind.

Dichiarazione CE di conformità

Dichiariamo, assumendone la responsabilità, che i prodotti descritti nel presente manuale sono conformi alle disposizioni delle direttive CEE di cui sott e alle lagislazionni nazionali che li recepiscono

Declaración CE de conformidad

Declaramos, bajo nuestra responsabilidad, que los productos designados en este manual son conformes a las disposiciones de las directivas CEE enunciadas a continuacion, asi como a las legislaciones nacionales que las contemplan.

WMT 090914 RC HIGH TECH
REF : 7 SP 09

MACHINERY DIRECTIVE 98 / 37 / CEE
LOW VOLTAGE DIRECTIVE (DBT) 73 / 23 / CEE AMENDED BY DIRECTIVE 93 / 68 CEE
ELECTROMAGNETIC COMPATIBILITY DIRECTIVE 89 / 336 / CEE
PRESSURISE EQUIPMENT DIRECTIVE (DESP) 97 / 23 / CEE
SUB-MODULE A CATEGORY I

DIRECTIVE MACHINES 98 / 37 C.E.E.
DIRECTIVE BASSE TENSION (DBT) 73 /23 C.E.E. , AMENDEE PAR DIRECTIVE 93 / 68 C.E.E.
DIRECTIVE COMPATIBILITE ELECTROMAGNETIQUE 89 / 336 / C.E.E.
DIRECTIVE DES EQUIPEMENTS SOUS PRESSION (DESP) 97 / 23 C.E.E.
MODULE A CATEGORIE I

RICHTLINIE MASCHINEN 98 / 37 / EG
RICHTLINIE NIEDERSPANNUNG (DBT) 73 / 23 / EG ABGEÄNDERT DURCH DIE RICHTLINIE 93 / 68 EG
RICHTLINIE ELEKTROMAGNETISCHE VERTRÄGLICHKEIT 89 / 336 / EG
RICHTLINIE FÜR AUSRÜSTUNGEN UNTER DRUCK (DESP) 97 / 23 / EG
UNTER MODUL A, KATEGORIE I

DIRETTIVA MACHINE 98 / 37 / CEE
DIRETTIVA BASSA TENSIONE (DBT) 73 / 23 / CEE EMENDATA DALLA DIRETTIVA 93 / 68 CEE
DIRETTIVA COMPATIBILITA ELETTRONAGNATICA 89 / 336 / CEE
DIRETTIVA DEGLI IMPIANTI SOTTO PRESSIONE (DESP) 97 / 23 / CEE
SOTTOMODULO A, CATEGORIA I

DIRECTIVA MAQUIAS 98 / 37 / CEE
DIRECTIVA BAJA TENSION (DBT) 73 / 23 / CEE ENMENDATA POR LA DIRECTIVA 93/ 68 CEE
DIRECTIVA COMPATIBILIDAD ELECTROMAGNETICA 89 / 336 / CEE
DIRECTIVA DE LOS EQUIPOS A PRESION (DESP) 97 / 23 / CEE
BAJA MODULO A, CATEGORIA I

And that the following paragraphs of the harmonised standards have been applied.

Et que les paragraphes suivants les normes harmonisées ont été appliqués.

Und dass die folgenden Paragraphen der vereinheitlichten Normen Angewandt wurden.

E che sono stati applicati i seguenti paragrafi delle norme armonizzate.

Y que se han aplicado los siguientes apartados de las normas armonizadas.

NF EN 60 204-1 / 1998

NF EN 60 335-1 / 1995

NF EN 60 335-2-40 / 1994

NF EN 55 022 / 1998

NF EN 61 000-3-2 / 1998

NF EN 50 082-1 / 1998

NF EN 814 / 1997

NF EN 378 / 99

NF EN 255 / 1997

NF EN 60 204-1 / 1998

NF EN 60 335-1 / 1995

NF EN 60 335-2-40 / 1994

A Tillières Sur Avre
27570 - FRANCE
Le: 22/05/2002
Richard FALCO
Directeur Qualité





 **ELECTRA**

