



Service Manual

RSF-VFF Series

Indoor Units	Outdoor Units
<i>RSF045</i>	<i>VFF045</i>



REFRIGERANT

R410A

HEAT PUMP

SEPTEMBER 2011

SM RSF045 2-A.0 GB

LIST OF EFFECTIVE PAGES

Note: Changes in the pages are indicated by a “Revision#” in the footer of each effected page (when none indicates no changes in the relevant page). All pages in the following list represent effected/ non effected pages divided by chapters.

Dates of issue for original and changed pages are:

Original 0 March 2009

Total number of pages in this publication is 53 consisting of the following:

Page No.	Revision No. #		Page No.	Revision No. #		Page No.	Revision No. #
----------	----------------	--	----------	----------------	--	----------	----------------

Title 0
 A..... 0
 i..... 0
 1-1 - 1-2 0
 2-1 - 2-3 0
 3-1..... 0
 4-1 - 4-2 0
 5-1 - 5-12 0
 6-1 - 6-2 0
 7-1 - 7-5 0
 8-1..... 0
 9-1..... 0
 10-1 0
 11-8..... 0
 12-1..... 0
 13-10..... 0
 14-1..... 0

- Zero in this column indicates an original page.

*Due to constant improvements please note that the data on this service manual can be modified with out notice.

**Photos are not contractual.

Table of Contents

1.	INTRODUCTION	1-1
2.	PRODUCT DATA SHEET	2-1
3.	RATING CONDITIONS	3-1
4.	OUTLINE DIMENSIONS	4-1
5.	PERFORMANCE DATA & PRESSURE CURVES	5-1
6.	SOUND LEVEL CHARACTERISTICS	6-1
7.	WIRING DIAGRAMS	7-1
8.	ELECTRICAL DATA	8-1
9.	REFRIGERATION DIAGRAMS	9-1
10.	TUBING CONNECTIONS.....	10-1
11.	CONTROL SYSTEM	11-1
12.	TROUBLESHOOTING	12-1
13.	EXPLODED VIEWS AND SPARE PARTS LISTS.....	13-1
14.	APPENDIX A	14-1

1. INTRODUCTION

1.1 General

The **floor standing** fixed speed with nominal capacity 45kBtu/h is particularly suited for residential and light commercial heating and air conditioning needs.

The new line provides the most comfort and economical solutions of air conditioning.

1.2 Main Features

- R410A models
- Auto mode.
- Cooling
- Dehumidification
- Sleep mode
- ON/OFF timer
- Clock display
- Vertical Auto swing
- Horizontal Auto swing
- Intelligent deicing
- Memory from power failure
- Cold air prevention in heating
- Self diagnostic (Error indications) for ease of maintenance
- LED display
- Crank heater(Optional)

1.3 Indoor Unit

The indoor unit is floor standing and can be easily fitted to many types of residential and commercial applications.

It includes:

- Coil with hydrophilic aluminum fins.
- Motorized flaps (step motors)
- Advanced electronic control box assembly

1.4 Filtration

The series presents air filters:

- Easily accessible, and re-usable pre-filters (mesh)

1.5 Control

The microprocessor indoor controller, and an infrared remote control, supplied as standard, provide complete operating function and programming. For further details please refer to the Operation Manual, Appendix A.

1.6 Outdoor Unit

The outdoor units can be installed as floor or wall mounted units by using a wall supporting bracket. The metal sheets are protected by anti- corrosion paint work allowing long life resistance. All outdoor units are pre-charged. For further information please refer to the Product Data Sheet, Chapter 2.

It includes :

- Compressor mounted in a soundproofed compartment :
- Axial fan.
- Outdoor coil with hydrophilic louver fins for RC units.
- Outlet air fan grill.
- Service valves” flare” type connection.

1.7 Tubing Connections

Flare type interconnecting tubing to be produced on site.
For further details please refer to the Installation Manual, Chapter 10.

1.8 Inbox Documentation

Each unit is supplied with its own installation and operation manuals.

1.9 Matching Table

<p>OUTDOOR UNIT <i>ELAU-VFF045-H13</i></p>	<p>INDOOR UNIT <i>ELSI-RSF045-N13</i></p>
	
	<p style="text-align: center;">✓</p>

2. PRODUCT DATA SHEET

2.1 RSF045 / VFF045 R410A

Model Indoor Unit		RSF045	
Model Outdoor Unit		VFF 045	
Installation Method of Pipe		Flared	
Characteristics		Units	Cooling Heating
Capacity ⁽⁴⁾		Btu/hr	42310 46400
		kW	12.40 13.60
Power input ⁽⁴⁾		kW	4.94 4.84
EER (Cooling) or COP(Heating) ⁽⁴⁾		W/W	2.51 2.81
Energy efficiency class			
Power supply		V	380-415
		Ph	3
		Hz	50
Rated current		A	8.40 8.24
Power factor			0.85 0.85
Prated (IDU)		W	
Prated (IDU+ODU)(Cooling/Heating)		W	6400 / 5800(8300)
Starting current		A	
Circuit breaker rating		A	
INDOOR	Fan type & quantity		Centrifugal fan-1
	Fan speeds	H/M/L	RPM 500/460/420/380
	Air flow ⁽¹⁾	H/M/L	m3/hr 1800/1650/1500/1350
	External static pressure	Min	Pa
	Sound power level ⁽²⁾	H/M/L	dB(A) 62/60/58/56
	Sound pressure level ⁽³⁾	H/M/L	dB(A) 52/50/48/46
	Moisture removal		l/hr 6
	Condensate drain tube I.D		mm 18
	Dimensions	WxHxD	mm 518x1870x395
	Net Weight		kg 63
	Package dimensions	WxHxD	mm 2080x735x530
	Packaged weight		kg 89
	Units per pallet		units
	Stacking height		units
OUTDOOR	Refrigerant control		Capillary
	Compressor type,model		Scroll,Sanyo C-SBP160H38A
	Fan type & quantity		Axial fan-2
	Fan speeds	H	RPM 830
	Air flow	H	m3/hr 4000
	Sound power level	H	dB(A) 69
	Sound pressure level ⁽³⁾	H	dB(A) 59
	Dimensions	WxHxD	mm 1032x1250x412
	Net Weight		kg 110
	Package dimensions	WxHxD	mm 1110x1280x450
	Packaged weight		kg 121
	Units per pallet		Units
	Stacking height		units
	Refrigerant type		R410A
	Scharg		kg(5m) 3.6
	Additional charge		g/m 120
	Connections between units	Liquid line	In.(mm)
Suction line		In.(mm)	3/4"(19.05)
Max.tubing length		m.	Max. 40
Max.height difference		m.	Max.25
Operation control type			Remote control
Heating elements (Standard)		kW	2.5
Others			

⁽¹⁾Airflow in ducted units;at nominal external static pressure.

⁽²⁾Sound power in ducted units is measured at air discharge.

⁽³⁾Sound pressure level measured at 1-meter distance from unit.

⁽⁴⁾Rating conditions in accordance to ISO 5151 and ISO 13253 (for ducted units).

3. RATING CONDITIONS

Standard conditions in accordance with ISO 5151, ISO 13253 (for ducted units) and EN 14511.

Cooling:

Indoor: 27°C DB 19°C WB

Outdoor: 35°C DB

Heating:

Indoor: 20°C DB

Outdoor: 7°C DB 6°C WB

3.1 Operating Limits

R410A

		Indoor	Outdoor
Cooling	Upper limit	32°C DB 23°C WB	43°C DB
	Lower limit	21°C DB 15°C WB	18°C DB
Heating	Upper limit	27°C DB	24°C DB 18°C WB
	Lower limit	10°C DB	-7°C DB
Voltage	3PH	360 – 440 V	

4. OUTLINE DIMENSIONS

4.1 Indoor Unit: RSF045

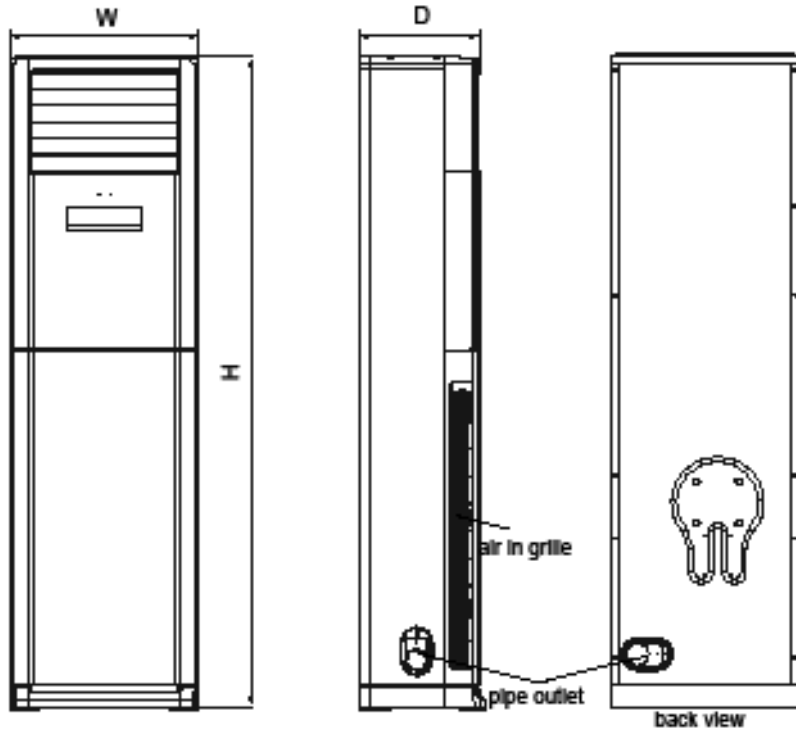

Model	W	H	D
RSF045	518	1870	395

4.2 Outdoor Unit:VFF045

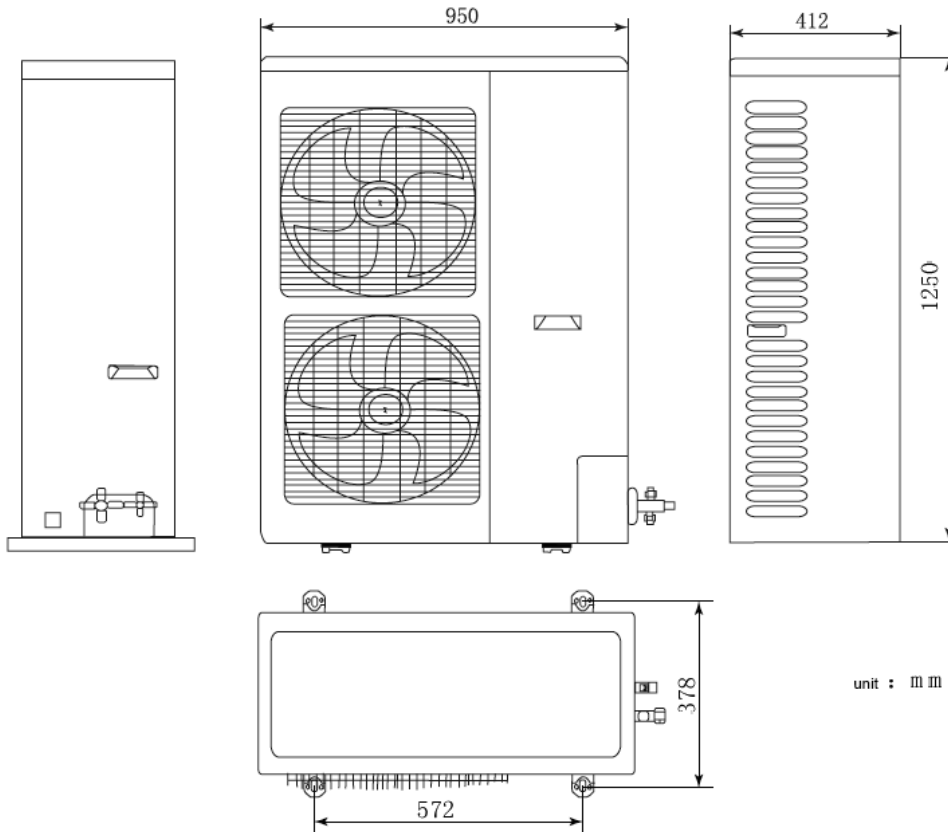

5. PERFORMANCE DATA

5.1 ELSI-RSF045-N13 / ELAU-VFF045-H13

5.1.1 Cooling Capacity (kW)

Entering Air DB OD Coil(°C)	Data	Entering Air WB/DB ID Coil(°C)				
		15/21	17/24	19/27	21/29	23/32
20	TC	12.65	13.33	13.75	14.07	14.38
	SC	8.33	8.78	9.15	9.41	9.59
	PI	3.80	3.82	3.83	3.85	3.86
25	TC	11.96	12.92	13.58	13.99	14.33
	SC	8.12	8.61	9.08	9.34	9.52
	PI	4.11	4.14	4.17	4.19	4.22
30	TC	11.19	12.18	13.16	13.63	14.03
	SC	7.86	8.36	8.88	9.15	9.32
	PI	4.43	4.50	4.54	4.57	4.61
35	TC	10.36	11.24	12.40	13.02	13.64
	SC	7.48	8.01	8.68	8.93	9.11
	PI	4.78	4.86	4.94	4.98	5.01
40	TC	9.42	10.26	11.19	12.24	12.86
	SC	7.05	7.58	8.21	8.47	8.65
	PI	5.16	5.24	5.33	5.39	5.45
46	TC	8.17	8.94	9.83	10.86	11.70
	SC	6.49	6.95	7.49	7.75	7.92
	PI	5.63	5.72	5.85	5.93	6.00

LEGEND

- TC – Total Cooling Capacity, kW
- SC – Sensible Capacity, kW
- PI – Power Input, kW
- WB – Wet Bulb Temp., (°C)
- DB – Dry Bulb Temp., (°C)
- ID – Indoor
- OU – Outdoor

5.1.3 Heating Capacity (kW)

ENTERING WB OD COIL(°C)	ENTERING AIR DB ID COIL(°C)					
	15		20		25	
	TH	PI	TH	PI	TH	PI
-10	7.14	3.87	6.87	4.12	6.60	4.33
-7	7.68	3.97	7.41	4.19	7.14	4.41
-2	8.16	4.02	7.89	4.26	7.62	4.50
2	9.93	4.21	9.52	4.48	9.11	4.74
6	14.01	4.53	13.60	4.84	13.12	5.14
10	15.23	4.78	14.82	5.11	14.42	5.46
15	16.46	4.99	16.05	5.37	15.64	5.71
20	17.34	5.13	16.93	5.57	16.46	6.00

LEGEND

- TH – Total Heating Capacity, kW
- PI – Power Input, kW
- WB – Wet Bulb Temp., (°C)
- DB – Dry Bulb Temp., (°C)
- ID – Indoor
- OU – Outdoor

5.1.4 Curves

5.1.4.1 Cooling

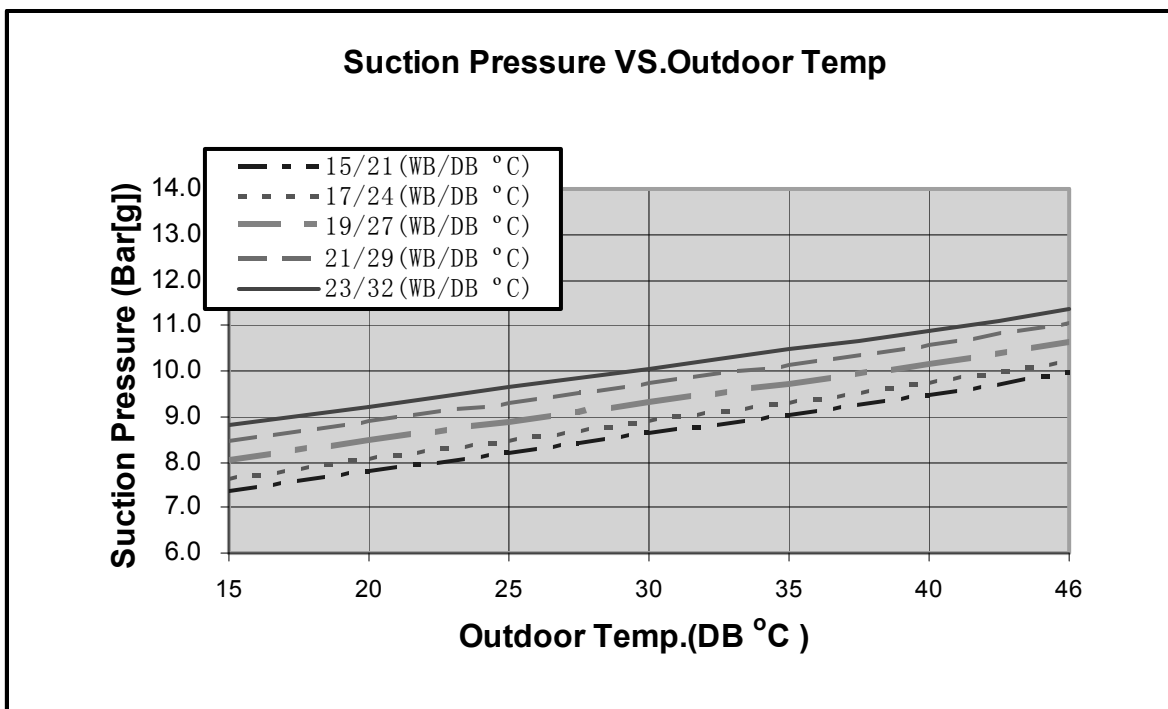

5.1.4.2 Heating

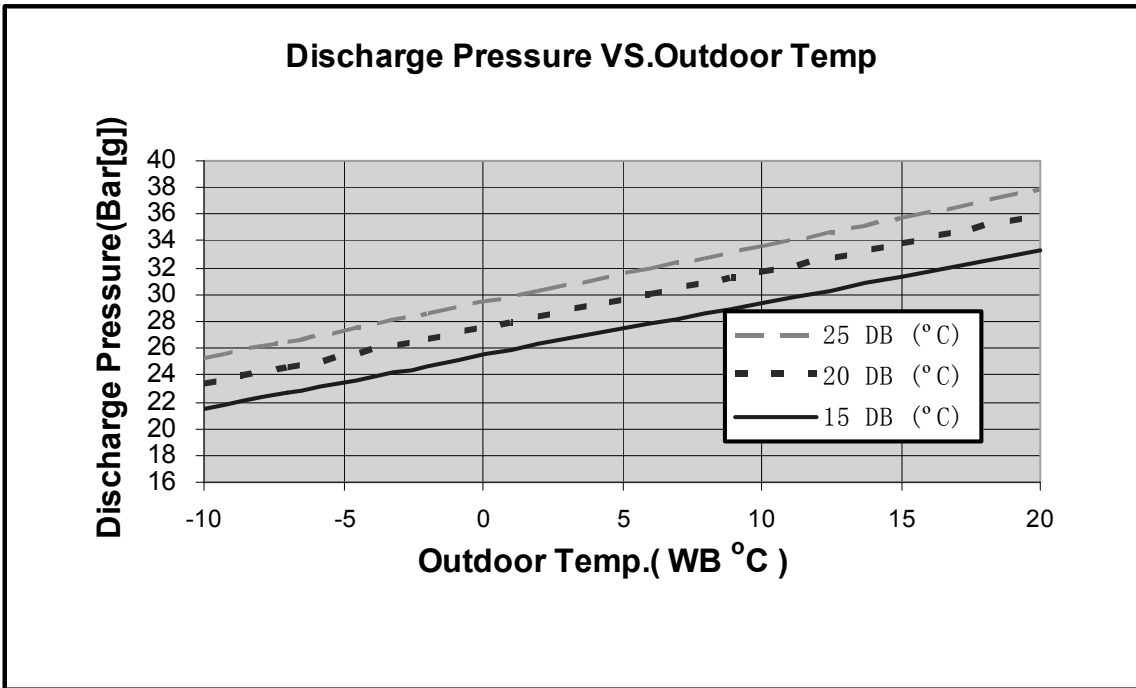

6. SOUND LEVEL CHARACTERISTICS

6.1 Sound Pressure Level - Indoor

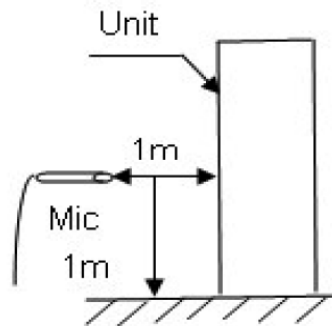
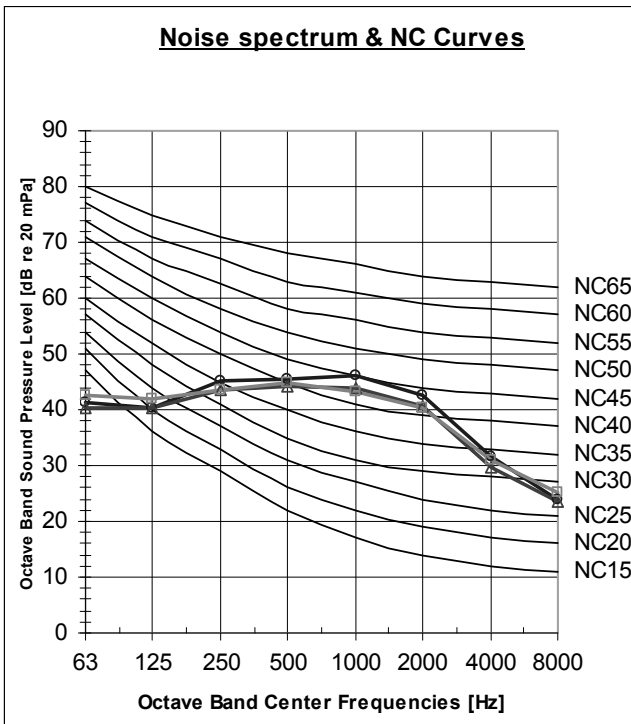

Fig. 1

6.2 Sound Pressure Level Spectrum - Indoor (Measured as Figure 1)

**ELSI-RSF045-N13
Cooling**



**ELSI-RSF045-N13
Heating**

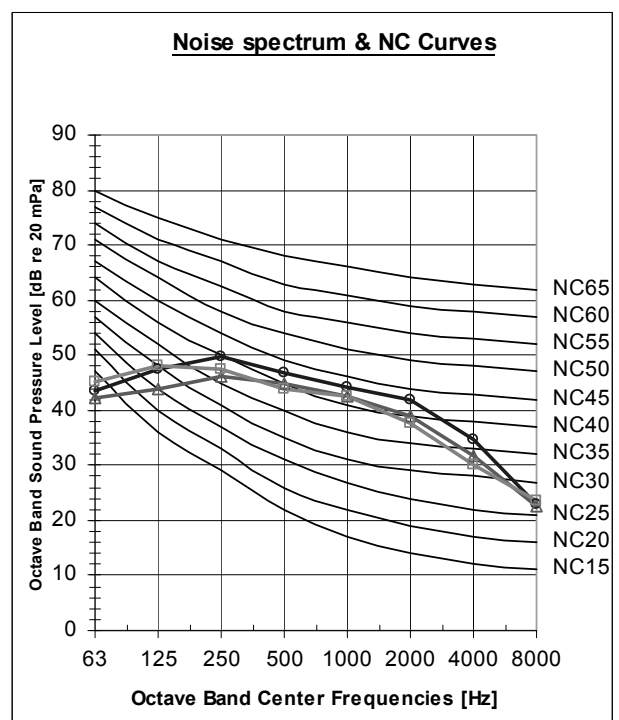

6.3 Sound Pressure Level - Outdoor

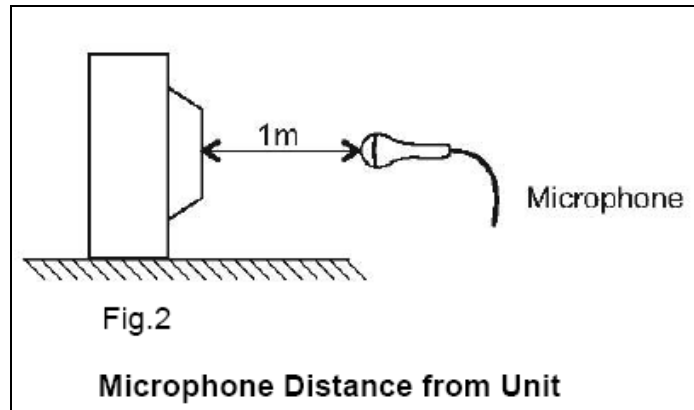

6.4 Sound Pressure Level Spectrum -Outdoor (Measured as Figure 1)

**ELAU-VFF045-H13
Cooling**

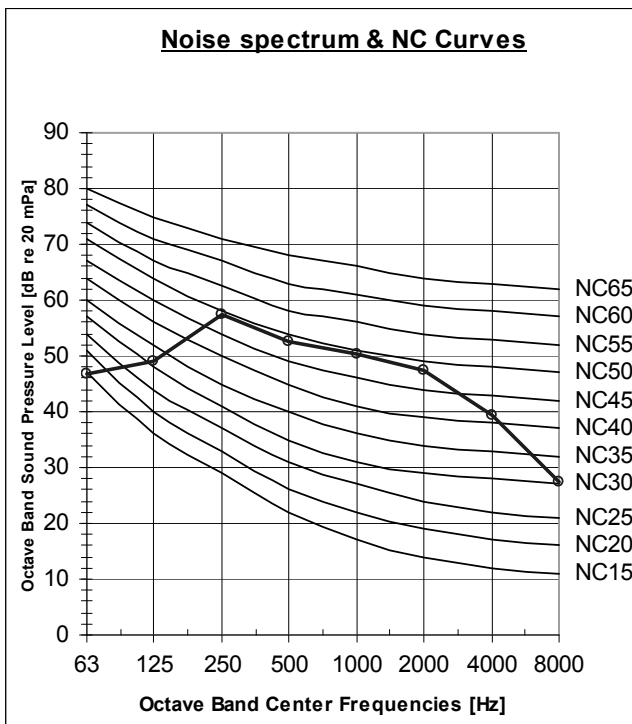

**ELAU-VFF045-H13
Heating**

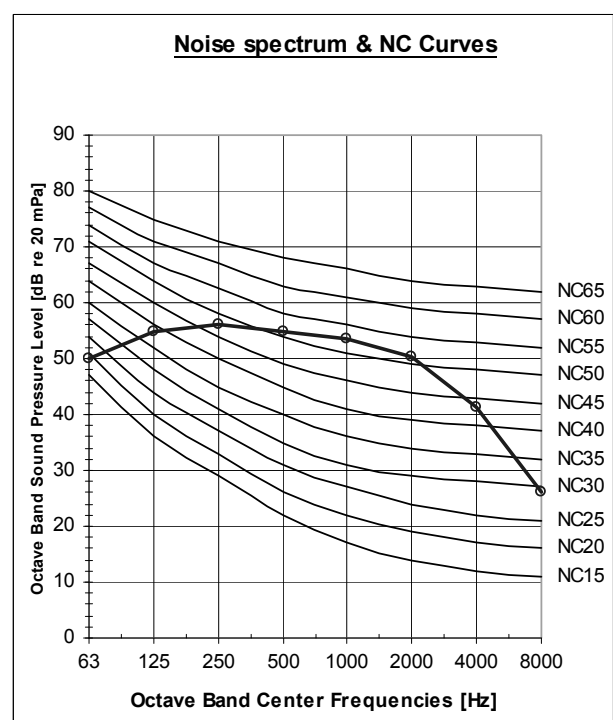

7. WIRING DIAGRAMS

7.1 ELSI-RSF045-N13

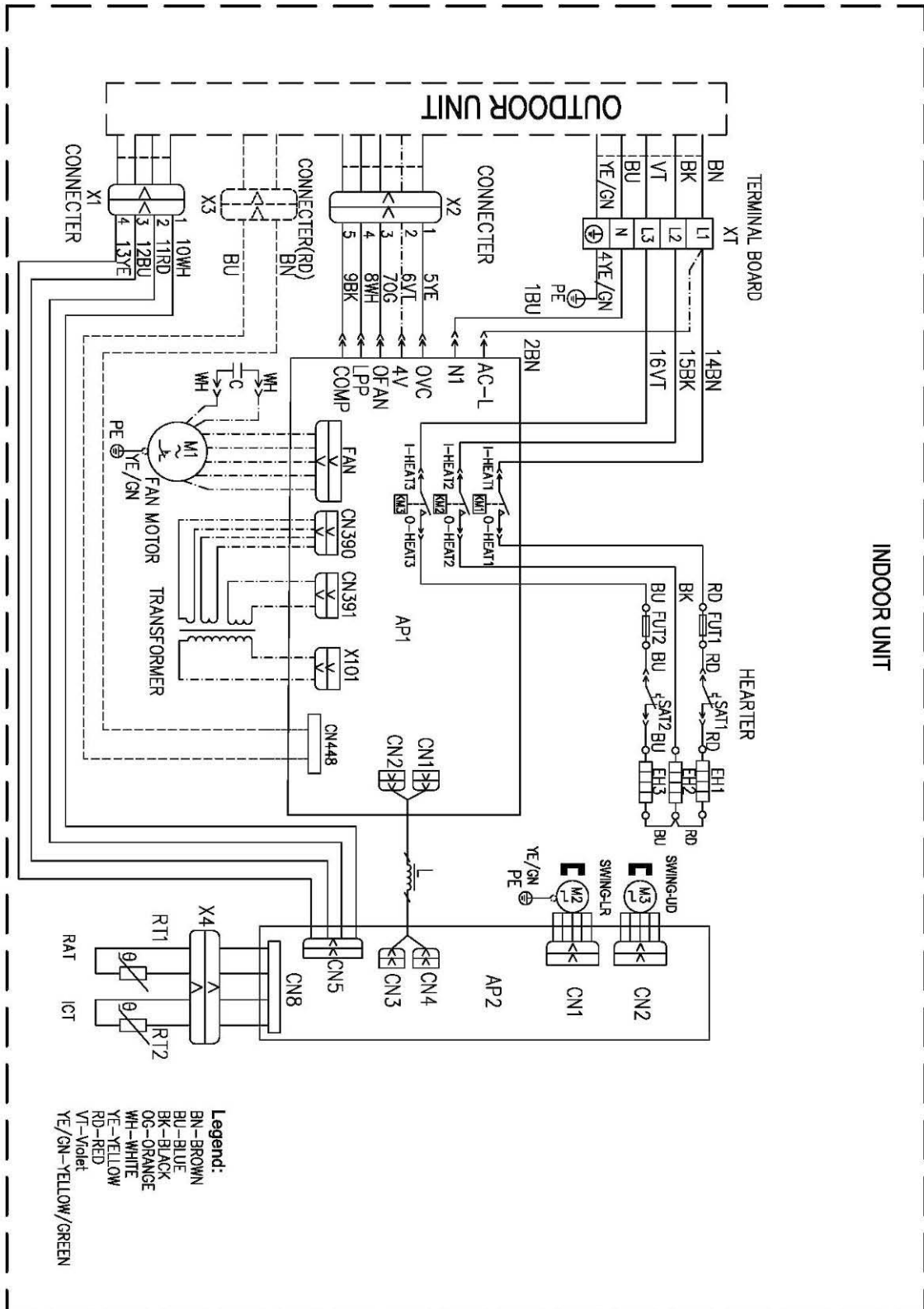

7.2 ELAU-VFF045-H13

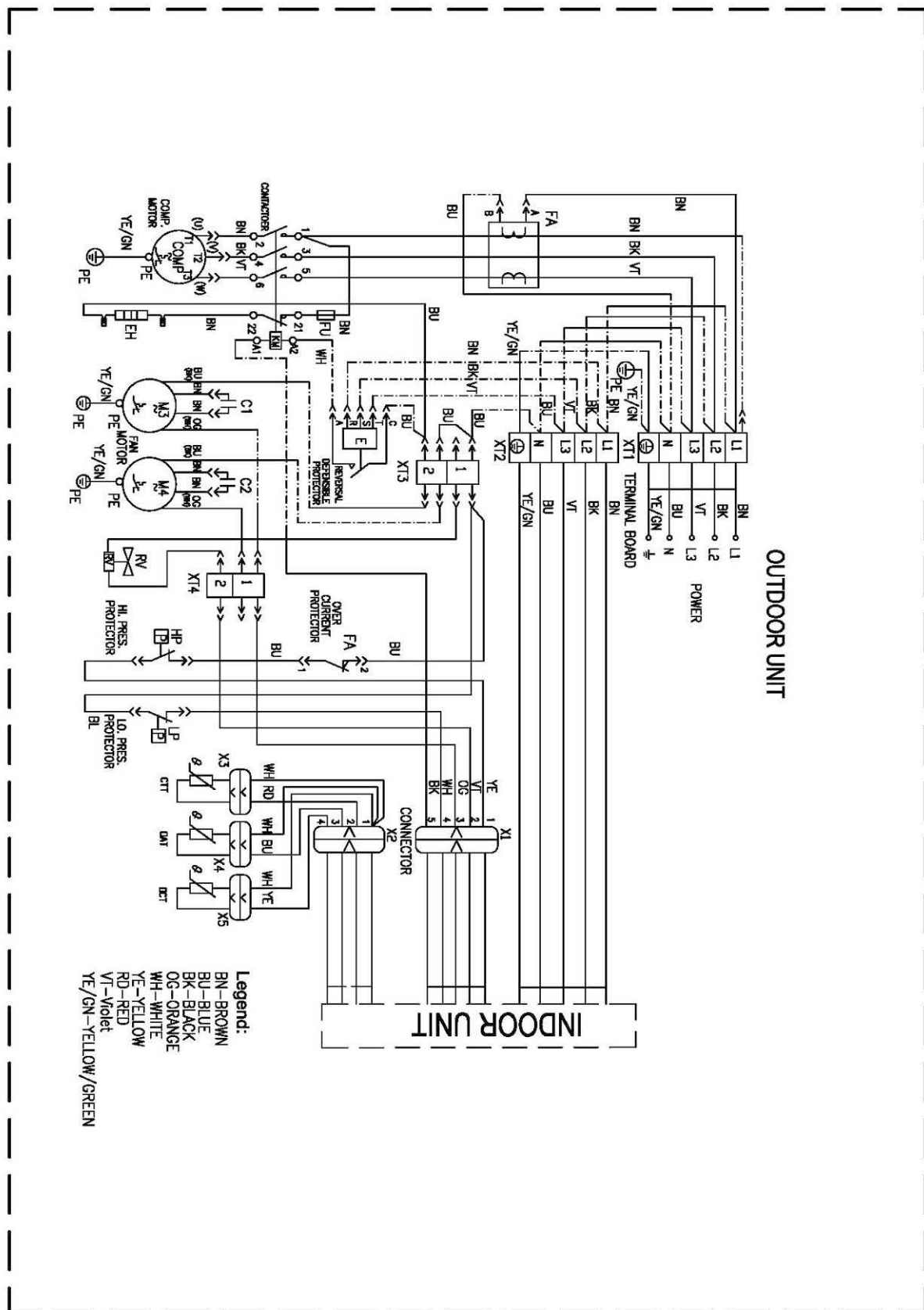

8. ELECTRICAL DATA

8.1 RSF045

MODEL	
Power Supply	Outdoor
	3PH-380-415V-50Hz
Fuse(A)	25
Power Supply Wiring No. X Cross Section mm ²	5 x 2.5 mm ²
Power Supply Wiring No. X Cross Section mm ² (To IDU)	5 x 1.0 mm ²
Interconnecting Cable Model No. X Cross Section mm ²	5x1.0mm ² + 4x1.0mm ²

Note:

Power wiring cord should comply with local laws and electrical regulations requirements.

9. REFRIGERATION DIAGRAMS

9.1 RSF045/VFF045

9.1.1 Cooling Mode

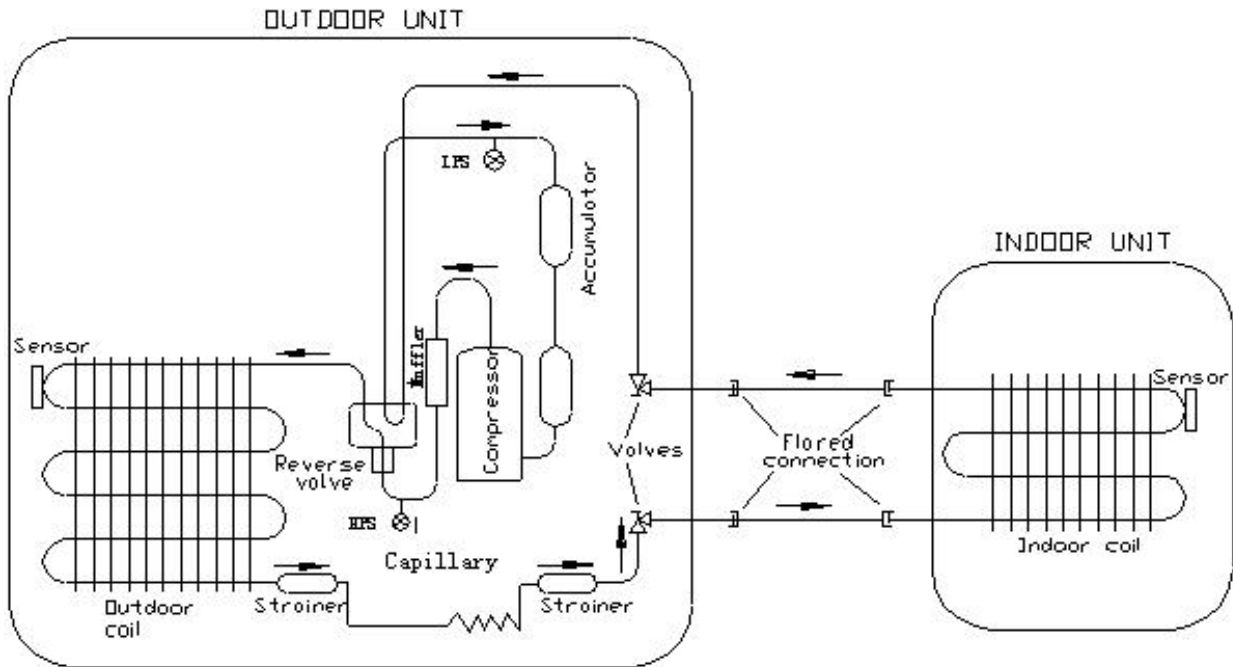

COOLING & DRY MODE

9.1.2 Heating Mode

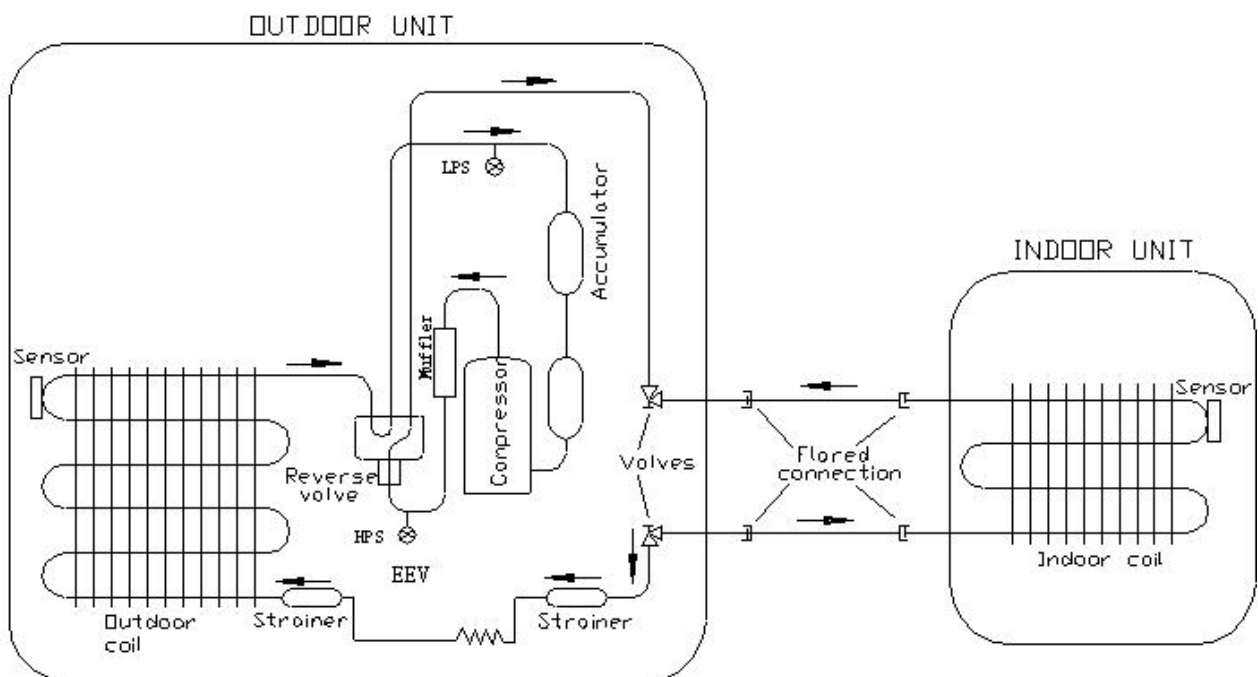

HEATING MODE

10. TUBING CONNECTIONS

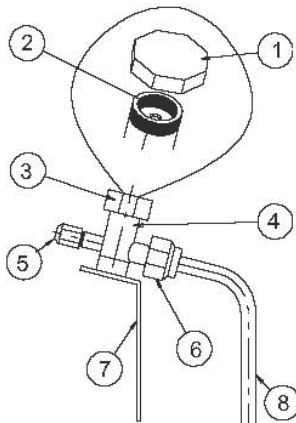
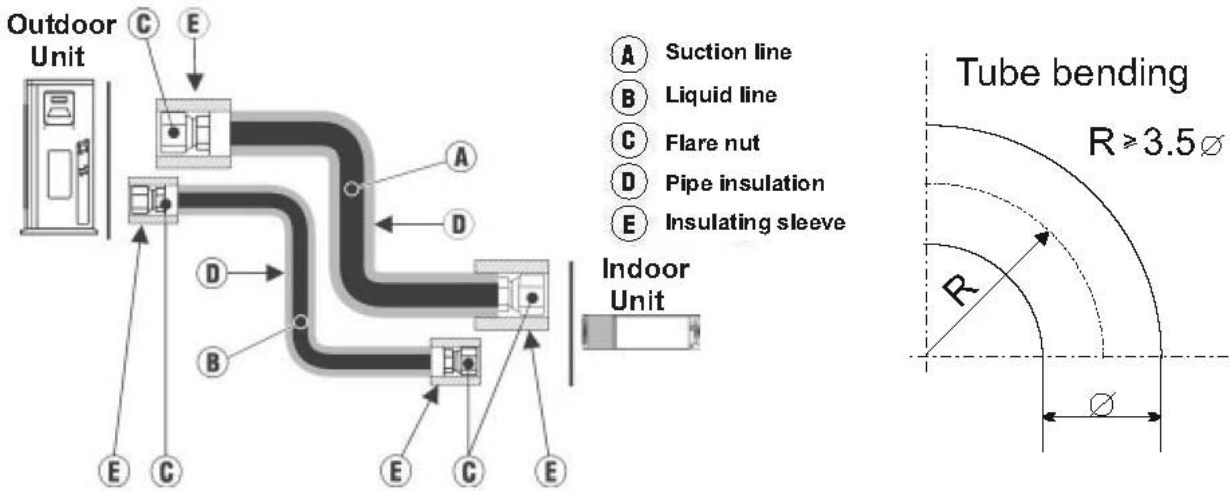

TUBE (Inch)	1/4"	3/8"	1/2"	5/8"	3/4"
TORQUE (Nm)					
Flare Nuts	11-13	40-45	60-65	70-75	80-85
Valve Cap	13-20	13-20	18-25	18-25	40-50
Service Port Cap	11-13	11-13	11-13	11-13	11-13

1. Valve Protection Cap-end
2. Refrigerant Valve Port (use Allen wrench to open/close)
3. Valve Protection Cap
4. Refrigerant Valve
5. Service Port Cap
6. Flare Nut
7. Unit Back Side
8. Copper Tube

When the outdoor unit is installed above the indoor unit an oil trap is required every 5m along the suction line at the lowest point of the riser. In case the indoor unit is installed above the outdoor, no trap is required.

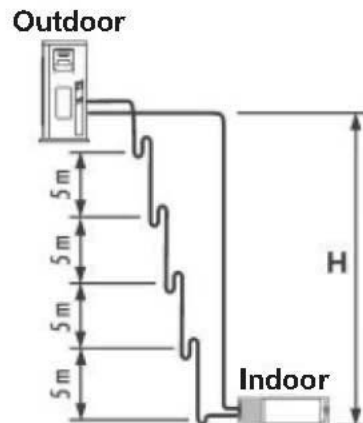

11. CONTROL SYSTEM

11.1 Fan Mode

In this mode, the indoor fan may run at high, medium, low and automatic speed. The compressor, outdoor fan and 4-way valve will be OFF.

In this mode, the range of setting temperature is 16°C~30°C.

Auto Fan setting

In AutoFan user setting, fan speed will be adjusted automatically according to the difference between actual room temperature (RAT) and user set point temperature (SPT).

Indoor Fan speed		High	Medium	Low
RAT-SPT	Cooling	≥ 2	(0,2)	≤ 0
	Heating	≤ 0	(1,3]	> 3

11.2 Cool Mode

When $RT \geq SPT + 1^\circ\text{C}$, the unit will run in cooling mode. Meanwhile, compressor, outdoor fan will start running, and indoor will run at setting fan speed;

When $RT \leq SPT - 1^\circ\text{C}$, the unit is at OFF status in cooling mode. Meanwhile, compressor, outdoor fan will all stop running, while indoor fan will run at setting fan speed;

When $SPT - 1^\circ\text{C} < RT < SPT + 1^\circ\text{C}$, the unit will keep previous running status.

In this mode, the temperature setting range is 16°C~30°C and the initial value is 25°C. The indoor fan will run according to the setting, if AutoFan is set, fan speed will be adjusted automatically according to the SPT and RAT, refer to Sec 12.1

11.3 Heat Mode

When $RT \leq SPT - 1^\circ\text{C}$, the unit will run in heating mode. Meanwhile, compressor and outdoor fan will start running. Indoor fan maybe start running after delayed for a period of time to prevent blowing out cold air. The RV will be ON after compressor was ON for 20s.

When $RT \geq SPT + 1^\circ\text{C}$, compressor and outdoor fan will stop running. The RV is ON and indoor fan will stop running after running at low fan speed for 10s.

When $SPT - 1^\circ\text{C} < RT < SPT + 1^\circ\text{C}$, the unit will keep original running status.

In this mode, the SPT range is 16°C~30°C and the initial value is 25°C. When tuning off the unit in heating mode or switching to other modes from heating mode, the RV will be OFF after 2mins delayed.

Residual heat blowing function

During heating, when the stopping condition for the compressor is reached, the compressor and the outdoor fan motor stop running. The indoor fan will stop after running for 10s at low speed

11.4 Auto Cool/Heat Mode

In AUTO mode, the system selects the running mode (COOL/HEAT/FAN) automatically according to the room temperature. The display shows the actual running mode and setting temperature. There will be 30s delay for mode conversion.

1. When $RAT \geq 26$ degree, the cooling mode is selected.

2. When $RAT \leq 20$ degree, the unit runs in heating mode

3. When 20 degree $< RAT < 26$ degree, upon initial startup, the unit will enter auto mode and run in automatic fan mode. If the other mode changes into auto mode, the previous running mode will remain.

11.5 Dry Mode

When $RT > SPT + 2^{\circ}\text{C}$, the unit will run in cooling mode. Meanwhile, compressor and outdoor fan will start running, and indoor fan will run at low fan speed;

When $SPT - 2 \leq RT \leq SPT + 2^{\circ}\text{C}$, compressor and outdoor fan will run for 6mins and then stop for 4 mins, and they will run like that circularly. Indoor fan will run at low fan speed;

When $RT < SPT - 2^{\circ}\text{C}$, compressor and outdoor fan will stop running, while indoor fan will run at low fan speed.

In this mode, the temperature setting range is $16^{\circ}\text{C} \sim 30^{\circ}\text{C}$ and the initial value is 25°C

11.6 Refrigerant Recovery mode

- Power on the unit,
- Set the A/C at FAN mode, low fan speed by remote controller and the indoor temperature is set as 20°C ;
- Press the light button on remote controller for twice continuously within 5s; The compressor will be on to recovery the refrigerant.

After compressor has run for 3mins, please close the cut-off valve completely.

Notice: 1. After refrigerant is recovered, if the recovery operation should be operated again, please power off at first and then power off again.

2. the low pressure switch can't be short circuited.

3. When the protector for low pressure switch has an action, compressor and outdoor unit will stop running automatically. Please close the cut-off valve immediately.

11.7 Turbo mode

Press TURBO button in cooling/heating mode, the unit will operate Turbo Mode.

Under this mode, IFAN will operate at super High speed.

Either pressing TURBO button again or selecting other fan speed can cancel the Turbo Mode.

Turbo Mode does not exist in Auto Mode, Dry Mode and Fan Mode.

11.8 Protections

11.8.1 Indoor Coil Defrost Protection

IDU freezing protection is functioned by the ICT to prevent the IU exchanger from freezing in cooling mode.

Compressor will stop when $ICT \leq -2^{\circ}\text{C}$ for continuous 3 mins.

The unit will not restart until $ICT \geq 10^{\circ}\text{C}$ and the compressor is OFF for 6 minutes.

11.8..2 High Pressure Protection of Compressor by high pressur switch

When high pressure protection is detected for 3 seconds continuously, the high pressure switch is 4.2Mpa , the unit will stop and report the fault, it can not resume running automatically and display malfunction, it can resume by pressing ON/OFF.

11.8.3 Low Pressure Protection of Compressor by low pressure switch

- Comp is on,

After the compressor has run for 2 minutes, the unit will begin to detect the signal of low pressure switch, If it is detected within 60 seconds continuously that the low-pressure switch is cut off, the unit will stop, 3 min later, if the protection is gotten over, the unit will resume operation automatically. Or else, the fault (E3) will display and the unit can not resume operation automatically. It can resume by pressing ON/OFF.

- Comp is off

If it's detected that the low pressure switch is cut off for 30s continuously, the unit will stop running. Meanwhile, E3 will be displayed and the unit can't resume running automatically. Only after restarting up the unit and the low pressure switch is resumed, the unit can resume running.

11.8.4 Compressor over Heating Protection

After the compressor is started up, if it's detected that the discharge temperature is too high for 30s successively, the unit will stop running. When compressor has stopped for 3mins and discharge temperature resumes to normal range $CTT < 90^{\circ}\text{C}$, the unit will resume running.

If above protection is occurred for twice successively, the complete unit can't resume running and E4 will be displayed. When restarting up the unit and $CTT < 90^{\circ}\text{C}$, the unit will run at setting mode.

If turning on the unit to turn to heating mode or switching to heating mode from other modes, discharge protection will be shielded for 1min when compressor is started up for the first time.

11.8.5 Compressor over Current Protection

After compressor is started up, if it's detected that the current exceeds I_0 ($I_0 = 25\text{A}$) for 3s successively, the unit will stop running. After compressor has stopped for 3mins, the unit will resume original running status. If protection times exceeds 6 times, indicator will blink and display E5 and the unit can't resume original running status.

The unit can only resume running after restarting up the unit.

11.8.6 Outdoor Coil Deicing Protection

This protection is for Heat Pump Only

This protection is carried out by the cooling cycle (reverse cycle). The defrosting time or outdoor heat exchanger temperature must be more than its setting values when finishing the deicing protection.

In the deicing protection, IFAN is forced OFF.

Deicing Starting Conditions

The starting conditions must be made with the outdoor air temperature (OAT) and outdoor coil temperature (OCT). Under the conditions that the system is in heating operation for certain period (Accumulated time)

Deicing process

H1 will be displayed during deicing. If there's auxiliary heating, auxiliary heating will be stopped and then compressor, indoor fan and outdoor fan will stop running after 1min delayed. 3mins later, the four-way valve will be OFF. After four-way valve is OFF for 30s, compressor will be started up. After deicing is finished, compressor will stop running, while the four-way valve will be ON. 30s later, compressor and outdoor fan will be restarted up. Indoor fan is running at anti cold air status.

The max Deicing Time is 12 minutes.

11.8.7 Overheating protection in heating mode

In heating mode, when it's detected that the evaporator tube temperature (ICT) is too high, outdoor fan will stop running; when evaporator tube temperature resumes to normal range, outdoor fan will be started up.

11.9 Indoor Unit Controllers and Indicators

Remote control window

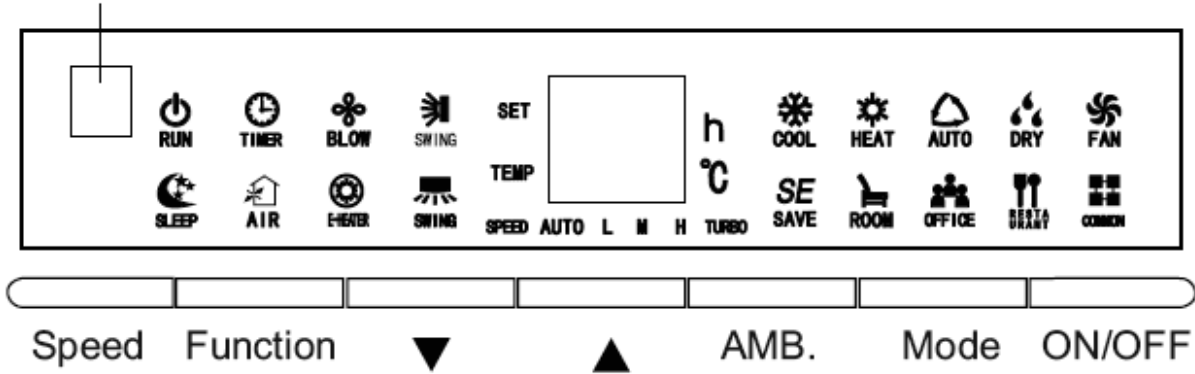

Indicator	Description
RUN	Lights up when the Air Conditioner is ON ,Blink when the unit is during protection
TIMER/BLOW/SLEEP/AIR/E-HEATER/AUTO(FAN) L M H/SAVE/ROOM/OFFICE/RESTRANT/COMMON	The relative LED will Light up when the corresponding function is set
COOL/HEAT/AUTO/DRY/FAN	The corresponding LED will light up when the unit is running in one of mode, if in AUTO mode, the AUTO LED and the actual running mode LED will light up
Two 7-segment	<ul style="list-style-type: none"> The default display is room temperature The SPT will display when the unit is on H1 will display when the unit is during deicing The fault code will display when the unit is under protection, the error code will display circularly when multiple malfunction is occurred When timer is setting, the SPT, Timer, RAT will be displayed in sequence, and every will display for 5 s

Button	Description
ON/OFF	Turn ON or OFF unit by pressing this button
Mode	Select the mode by pressing this button, the sequence is Auto, cooling, dry, fan, heating
AMB.	Press the AMB.button, the Save mode, room mode, office mode, restaurant mode, common mode will be selected in sequence. <ul style="list-style-type: none"> In room mode, office mode, restaurant mode, The SPT, fan speed and louver will run at the default status. In save mode, room mode, office mode, restaurant mode, the sleep function is inactive In save mode, the SPT and fan speed will be adjusted automatically. When using RC the unit can only turn to Save and common mode.
UP/DOWN	<ul style="list-style-type: none"> Change SPT During function setting, choose or exit the function Press both up and down button, these button will be lock, press them again, unlock these buttons Press up button for 20 sec, the unit will force to heating mode Press down button for 20 sec, the unit will force to cooling mode
Function	Select the function(vertical louver/horizontal louver/blow/E-heater/timer/air/sleep/turbo, etc), the function can be set or exit by up/down botton
Speed	Select the fan speed by pressing this button, the sequence is Auto, low, medium, high

12. TROUBLESHOOTING

12.1 ELECTRICAL & CONTROL TROUBLESHOOTING

12.1.1 Precautions before Performing Inspection or Repair

Be cautious during installation and maintenance. Do operation following the regulations to avoid electric shock and casualty or even death due to drop from high attitude.

* **Static maintenance** is the maintenance during de-energization of the air conditioner. For static maintenance, make sure that the unit is de-energized and the plug is disconnected.

* **Dynamic maintenance** is the maintenance during energization of the unit. Before dynamic maintenance, check the electricity and ensure that there is ground wire on the site. Check if there is electricity on the housing and connection copper pipe of the air conditioner with voltage tester. After ensure insulation place and the safety, the maintenance can be performed.

Take sufficient care to avoid directly touching any of the circuit parts without first turning off the power. At time such as when the circuit board is to be replaced, place the circuit board assembly in a vertical position. Normally, diagnose troubles according to the trouble diagnosis procedure as described below. (Refer to the check points in servicing written on the wiring diagrams attached to the indoor/outdoor units.)

Precautions when inspecting the control section of the outdoor unit:

A large-capacity electrolytic capacitor is used in the outdoor unit controller (inverter). Therefore, if the power supply is turned off, charge (charging voltage DC280V to 380V) remains and discharging takes a lot of time. After turning off the power source, if touching the charging section before discharging, an electrical shock may be caused.

The outdoor unit can not be started up until the unit is de-energized for 20min

12.1.2 Confirmation

12.1.2.1 Confirmation of Power Supply Confirm that the power breaker operates (ON) normally;

12.1.2.2 Confirmation of Power Voltage Confirm that power voltage is AC380-415V \pm 10% for three phase. If power voltage is not in this range, the unit may not operate normally.

12.1.3 Judgment by Indoor Unit Diagnostics

The error code will be directly displayed through indoor display .

12.1.3.1 Unit Diagnostics and Corrective Actions

Indicator	Failure	Possible Reasons/Corrective actions
E1	High pressure protection	<ul style="list-style-type: none"> Refrigerant was superabundant Poor heat exchange (including blockage and bad radiating environment) Too high ambient temperature
E3	Low pressure protection	<ul style="list-style-type: none"> Refrigerant leakage Poor heat exchange (including blockage and bad radiating environment) System is blocked
E4	Compressor over heating	<ul style="list-style-type: none"> Refrigerant leakage Poor heat exchange Too high ambient temperature
E5	Over current	<ul style="list-style-type: none"> Supply voltage is too low Too high ambient temperature Poor heat exchange
F1	RAT failure	<ul style="list-style-type: none"> Senor was broken or damaged PCB temperature detection circuit has problem
F2	ICT failure	
F3	OAT failure	
F4	OCT failure	
F5	CTT failure	

12.1.4 Checking the refrigeration system

The performance curves given in this manual are given when high indoor fan speed is selected. Please refer to the performance curve to check the system pressure and other thermodynamic measures.

12.2 Simple procedures for checking the Main Parts

12.2.1 Checking Mains Voltage.

Confirm that the Mains voltage is between 380VAC and 415 VAC. If Mains voltage is out of this range, abnormal operation of the system is expected. If in range check the Power (Circuit) Breaker and look for broken or loosed cable lugs or wiring mistake(s).

12.2.2 Checking Power Input.

If Indoor unit power LED is unlighted, power down the system and check the fuse of the Indoor unit. If the fuse is OK replace the Indoor unit controller. If the fuse has blown, replace the fuse and power up again.

Checking Power Input procedure for the Outdoor unit is the same as with the Indoor unit.

12.2.3 Checking the Outdoor Fan Motor.

Check the voltage between two pins(Hi and N) of connector Controller OFAN, normal voltage is 220~240VAC.

12.2.4 Checking the Compressor.

Three coil resistance is same. Check the resistance between three poles. The normal value should be 3 ohm@25°C.

12.2.5 Checking the Reverse Valve (RV).

Running in heating mode, check the voltage between two pins of reverse valve connector, normal voltage is 220~240VAC.

13. EXPLODED VIEWS & SPARE PART LIST

13.1 Exploded views of indoor unit ELSI-RSF045-N13

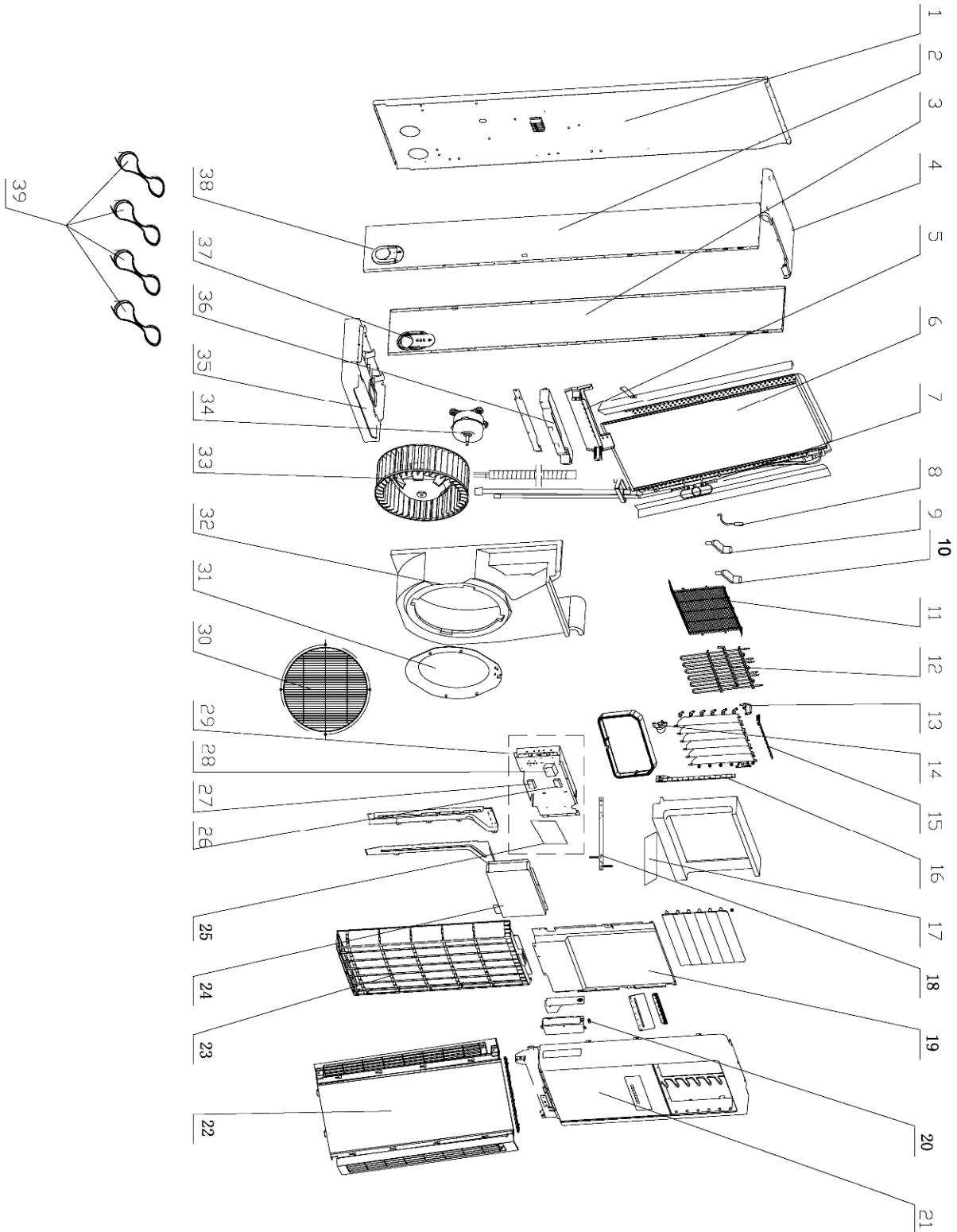

13.2 Spare part list of indoor unit ELSI-RSF045-N13

NO.	Part Code	Part Description	qty
1	01304290	Rear Plate Assy	1
2	0130430401	Left Side Plate Sub-Assy	1
3	0130430301	Right Side Plate Sub-Assy	1
4	22244152	Top Cover Sub-Assy	1
5	01364154D	Breakwater Sub-Assy	1
6	0100408101	Evaporator Assy	1
7	0300401101	Capillary sub-assy (heating)	1
8	39000190	Temperature Sensor	1
9	10564201	Crankshaft	1
10	10564204	Crankshaft	1
11	01474034	Rear Grill	1
12	32004079	Electric heater	1
13	1521421102	Step Motor	1
14	1521400801	Step Motor	1
15	10584218	Swing lever	1
16	10584089	Guide blade lever	1
17	30563195	Display Board	1
18	01384063	Propeller housing press plate sub-assy	1
19	01364174	Air Guard Assy	1
20	70810302	Female Clip	1
21	2000453403_K47371	Air Outlet Panel Assy	1
22	20004536	Air Intake panel Assy	1
23	11124100	Filter Sub-Assy	1
24	01404388	Electric Box Cover Sub-Assy	1
25	30134135	Main Board	1
26	33010037	Capacitor	1
27	42010258	Terminal Board	1
28	43110287	Transformer	1
29	0140484201	Electric Box Assy	1
30	01474027	Protection grill nets	1
31	10374435	Flow Guide Loop	1
32	12104058	Propeller Housing Sub-assy	1
33	10314401	Centifugal Fan	1
34	1501442404	Motor	1
35	22224020	Chassis	1
36	12314811	Water Tray Sub-Assy	1
37	2611408801	Baffle Plate	3
38	2224422101	Rear Cover	3
39	400205391	Connecting Cable	1
	05235434	Drainage Pipe Sub-assy	1
	49010104	Magnetic Ring	1
	05212423	Tube Sensor Bushing	1
	400205392	Power Cord	1
	40032117	Connecting Cable	1
	40030328	Connecting Cable	1
	01074011	Left support/Evaporator Assy	1
	01074012	Right support/Evaporator Assy	1
	30510136_K47371	Remote Controller	1
	24254018	Screw Cover	2
	42020063	Sensor Insert	1

45034088D	Button	1
2000453502_K47371	Air Outlet Panel Sub-assy	1
06640104	Connector Cap	1
01384201	Wire Clamp	1
11124103	Filter sub-assy(upper)	1
11128633	Filter Sub-assy	1
07210029	Filter Sub-Assy	1
2019422801S	Decorative strip 2	1
1056420502	Crankshaft of Guide Louver	6
49010252	Radiator	1

13.3 Exploded views of outdoor unit ELAU-VFF045-H13

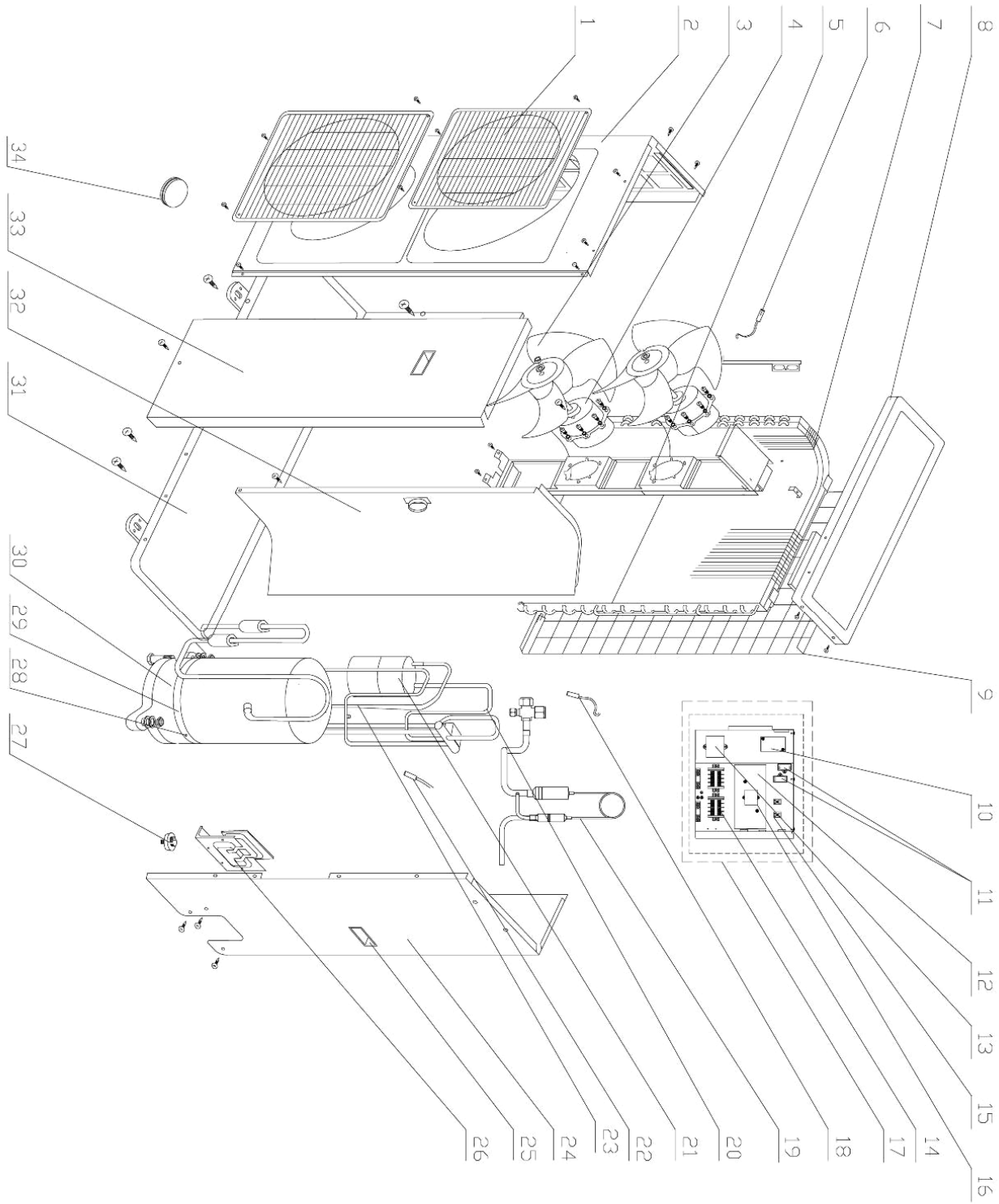

13.4 Spare part list of outdoor unit ELAU-VFF045-H13

NO.	Part Code	Part Description	qty
1	22414102	Panel Grille	2
2	01435436	Front Plate	1
3	10338731	Axial Flow Fan ϕ 472X165	2
4	15015421	Fan Motor	2
5	01705433	Motor Support Sub-Assy	1
6	39000199	Temperature Sensor	1
7	01105556	Condenser Assy	1
8	01255013P	Top Cover	1
9	01475432	Rear Grill	1
10	44010226	AC Contactor	1
11	33010010	Capacitor CBB61 3.5 μ F/450V	2
12	46020112	Over Current Protector	1
13	46020052	Anti-phase Protector	1
14	42010258	Terminal Board	2
15	42011103	Terminal Board 2-8	2
16	05212423	Tube Sensor Bushing	1
17	0140547039	Electric Box Assy	1
18	39000194	Tube Temperature Sensor(20K black)	1
19	03005479	Capillary Sub-Assy	1
20	03025235	4-way Valve Assy	1
21	07225018	Gas-liquid Separator Sub-Assy	1
22	39000163	Discharge Temperature Sensor(50K)	1
23	03635808	Inhalation Tube Assy	1
24	01303712	Rear Side Plate Sub-Assy	1
25	26235253	Handle	3
26	01715001	Valve Support Sub-Assy	1
27	06123401	Drainage Connector	1
28	42010157	Terminal	2
29	76515404	Electric Heater Band	1
30	00105021	Compressor C-SBP160H38A	1
31	012054335	Underpan Sub-Assy (sanyo)	1
32	01235440	Clapboard Sub-Assy	1
33	01305431	Front Side Plate	1
34	06813401	Choke Plug	3
	071302392	"Valve 1/2""	1
	43110242	Power Transformer	1
	43000338	4-way Valve	1
	76515202	Cable-Cross Loop	1
	76815206	Compressor Gasket	3
	42020063	Sensor Insert	1
	460200061	Pressure Switch	1
	46020007	Low Pressure Switch	1
	02145435	Liquid Accumulator Clamp	1
	430004002	4-way Valve Accessary	1
	07130212	Cut-off Valve	1

APPENDIX A

INSTALLATION AND OPERATION MANUAL

- ▶ **INSTALLATION & OPERATION MANUAL RSF045**