



DCINVERTER

INSTALLATION INSTRUCTIONS

ENGLISH

INSTRUCTIONS D'INSTALLATION

FRANÇAIS

INSTRUCCIONES DE INSTALACIÓN

ESPAÑOL

ISTRUZIONE PER L'INTALLAZIONE

ITALIANO

ИНСТРУКЦИИ ПО УСТАНОВКЕ

РУССКИЙ

 **ELECTRA**

INSTALLATION INSTRUCTIONS

ENGLISH







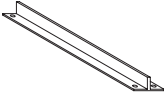

1. ACCESSORIES SUPPLIED WITH THE AIR CONDITIONER
2. LOCATION OF INDOOR AND OUTDOOR UNIT
3. INSTALLATION/SERVICE TOOLS (ONLY FOR R410A PRODUCT)
4. INSTALLATION OF THE INDOOR UNIT
5. CONDENSATE HOSE CONNECTION
6. ELECTRICAL CONNECTION BETWEEN INDOOR AND OUTDOOR UNIT
7. REFRIGERANT TUBING
8. FINAL TASKS

The appliance shall not be installed in the laundry.

NOTE: This manual is for single split applications.
For multi split applications please use installation manual supplied within outdoor unit package.

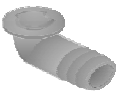
INSTALLATION INSTRUCTIONS FOR DCI SPLIT WALL MOUNTED AIR CONDITIONER

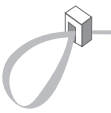
1 ACCESSORIES SUPPLIED WITH THE AIR CONDITIONER

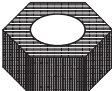
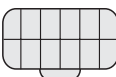
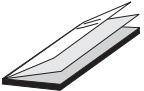
Shape	Name	Qty	Used for
	T support	2	Ceiling mounting of the indoor unit
	Remote control with batteries	1	Operation of unit
	Remote control bracket	1	Wall mounting of the remote control
	Screws	4	Ceiling mounting of indoor unit
	Screws dowels	4 2	Ceiling mounting of indoor unit Wall mounting of remote control bracket
	Outdoor unit drain connector	1	Outdoor unit water drain
	Mounting pads	4 4	Padding of indoor unit Padding of outdoor unit bottom support
	Cable ties	2	Securing wires in the indoor and outdoor unit
	Power input cable (Optional)	1	Connecting indoor unit power
	Nut	8	Ceiling mounting of indoor unit
	Air purifying filter (Optional)	1	Cleaning the air filter
	<ul style="list-style-type: none"> Remote control Unit operation Installation manual 	3	Users and installers reference

Indoor Unit's Accessories Only for One Unit.

2 LOCATION OF INDOOR AND OUTDOOR UNIT

Select the location considering the following:

INDOOR UNIT

- Do not install the cassette in a room where gasses, acids or inflammable products are stored, in order to avoid damage to the aluminium and copper evaporators and the internal plastic parts.
- Do not install the cassette in a workshop or a kitchen. Oil vapour attracted by the treated air could form deposits on the cassette evaporators and modify their performance or damage the cassette's internal plastic parts.
- Do not install the cassette in a laundry, or a room where steam is produced.
- The appliance must be positioned so that the plug is accessible.
- The indoor unit is to be built into a suspended ceiling with panels dimensions of 60 x 60cm².
- Installing the cassette will be easier with the use of a fork lift truck. Use the packing base by placing it between the cassette and the truck forks.
- It is recommended to install the cassette, as far as is possible, in the centre of the room, in order to optimise treated air distribution.
- For the chosen location, check that the distribution grilles can be removed and that there is sufficient space available for access for maintenance and repairs.

OUTDOOR UNIT

- The location must allow easy servicing and provide good air circulation as shown in fig 4.
- The unit may be suspended from a wall by a bracket (Optional) or located in a free standing position on the floor (preferably slightly elevated).
- If the unit is suspended, ensure that the bracket is firmly connected and the wall is strong enough to withstand vibrations.
- Unit location should not disturb neighbors with noise or exhaust air stream.
- Place the mounting pads under the unit legs.
- Refer to figure 4 for allowed installation distances.
- When the unit is installed on a wall, install the drain connector hose and drain plug as shown in fig 1 and fig 2.

Fig.1
1.Bottom of outdoor unit
2.Drain connector

Fig.2
Drain installation
Example

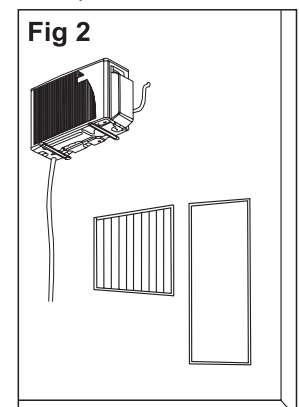
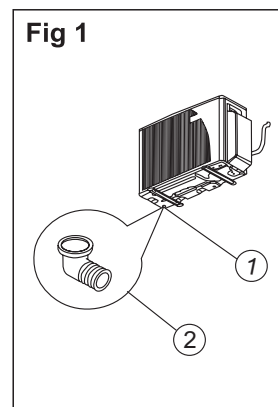

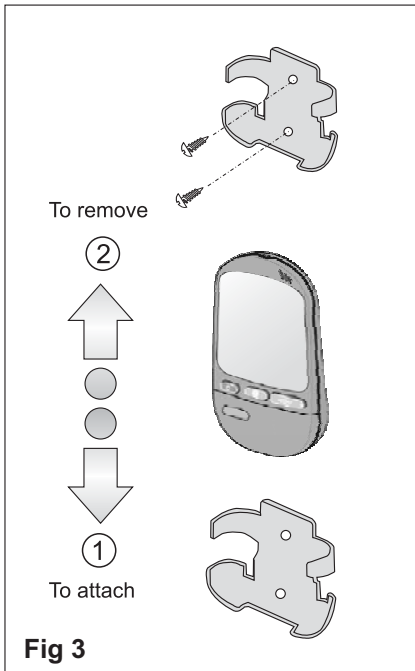
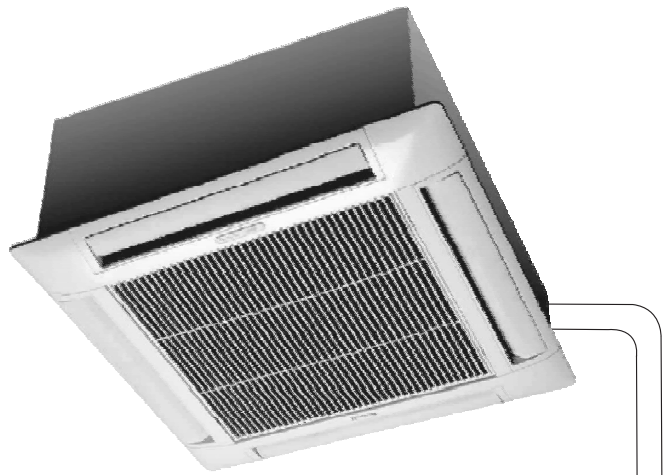

Capacity	L.MAX.(m)	H.MAX.(m)
9000 Btu (2500 W) model	20	10
12000 Btu (3500 W) model	30	10
18000 Btu (5000 W) model	30	10

NOTE:

- No additional charge is required.

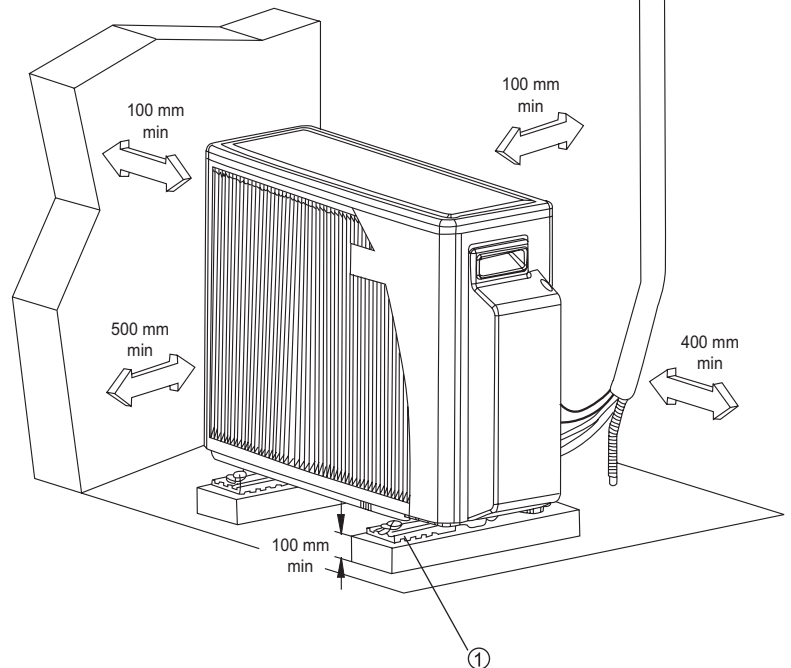

Fig.4
1. Mounting pads (× 4)

INSTALLATION/SERVICE TOOLS (ONLY FOR R410A PRODUCT)

CAUTION

New Refrigerant Air Conditioner Installation

THIS AIR CONDITIONER ADOPTS THE NEW HFC REFRIGERANT (R410A) WHICH DOES NOT DESTROY OZONE LAYER. R410A refrigerant is apt to be affected by impurities such as water, oxidizing membrane, and oils because the working pressure of R410A refrigerant is approx. 1.6 times of refrigerant R22. Accompanied with the adoption of the new refrigerant, the refrigeration machine oil has also been changed. Therefore, during installation work, be sure that water, dust, former refrigerant, or refrigeration machine oil does not enter into the new type refrigerant R410A air conditioner circuit.







To prevent mixing of refrigerant or refrigerating machine oil, the sizes of connecting sections of charging port on main unit and installation tools are different from those used for the conventional refrigerant units. Accordingly, special tools are required for the new refrigerant (R410A) units. For connecting pipes, use new and clean piping materials with high pressure fittings made for R410A only, so that water and/or dust does not enter. Moreover, do not use the existing piping because there are some problems with pressure fittings and possible impurities in existing piping.

Changes in the product and components

In air conditioners using R410A, in order to prevent any other refrigerant from being accidentally charged, the service port diameter size of the outdoor unit control valve (3 way valve) has been changed. (1/2 UNF 20 threads per inch)

- In order to increase the pressure resisting strength of the refrigerant piping, flare processing diameter and opposing flare nuts sizes have been changed. (for copper pipes with nominal dimensions 1/2 and 5/8)

New tools for R410A

New tools for R410A	Applicable to R22 model		Changes
Gauge manifold	×		As the working pressure is high, it is impossible to measure the working pressure using conventional gauges. In order to prevent any other refrigerant from being charged, the port diameters have been changed.
Charge hose	×		In order to increase pressure resisting strength, hose materials and port sizes have been changed (to 1/2 UNF 20 threads per inch). When purchasing a charge hose, be sure to confirm the port size.
Electronic balance for refrigerant charging	○		As working pressure is high and gasification speed is fast, it is difficult to read the indicated value by means of charging cylinder, as air bubbles occur.
Torque wrench (nominal dia. 1/2, 5/8)	×		The size of opposing flare nuts have been increased. Incidentally, a common wrench is used for nominal diameters 1/4 and 3/8.
Flare tool (clutch type)	○		By increasing the clamp bar's receiving hole size, strength of spring in the tool has been improved.
Gauge for projection adjustment	—		Used when flare is made by using conventional flare tool.
Vacuum pump adapter	○		Connected to conventional vacuum pump. It is necessary to use an adapter to prevent vacuum pump oil from flowing back into the charge hose. The charge hose connecting part has two ports -- one for conventional refrigerant (7/16 UNF 20 threads per inch) and one for R410A. If the vacuum pump oil (mineral) mixes with R410A a sludge may occur and damage the equipment.
Gas leakage detector	×		Exclusive for HFC refrigerant.

- Incidentally, the "refrigerant cylinder" comes with the refrigerant designation (R410A) and protector coating in the U.S's ARI specified rose color (ARI color code: PMS 507).
- Also, the "charge port and packing for refrigerant cylinder" requires 1/2 UNF 20 threads per inch corresponding to the charge hose's port size.

INSTALLATION OF THE INDOOR UNIT

CEILING MOUNTING

Mark the position of each support rod.

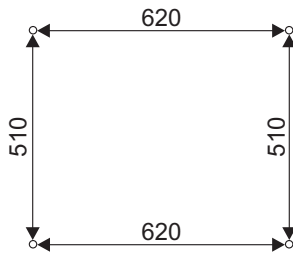

Fig 5

1. Fit the angle attachment fittings supplied with the cassette onto the threaded rods (not supplied). Recommended $\varnothing 6$ mm maximum $\varnothing 8$ mm. Take care to distance them from the suspended ceiling by 270mm or 107mm.

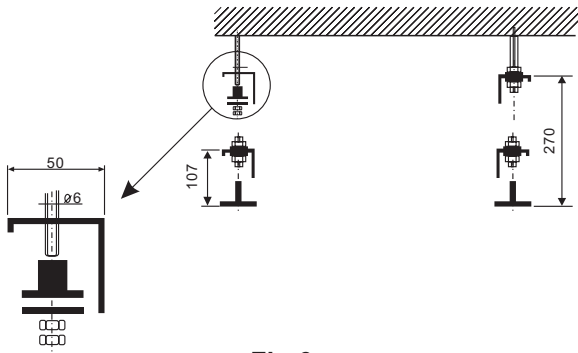

Fig 6

2. When fitting the angle attachment fittings in the low position, remove the insulating foam from around the mounting nuts.

3. The possibility of fitting the angle attachment fittings at different heights, leaves the installer the choice of mounting them on the cassette in the high or low position. Mounting them in the low position provides for more flexible installation.

4. Do not tighten the nuts or lock nuts. This will be done only after having set the cassette in its final horizontal position, when all the connections have been completed.

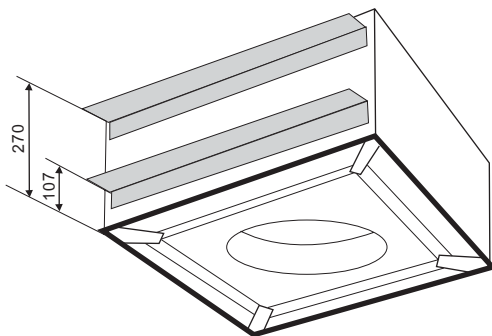

Fig 7

WARNING !

If it is intended to install ducting to an adjacent room, refer to Ceiling mounting for removal of the pre-punched panel before installing the cassette.

CASSETTE FITTING

Present the cassette to the support rods.

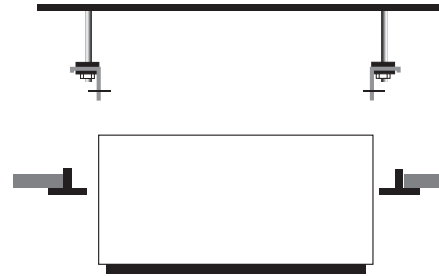

Fig 8

1. In the event that the suspended ceiling is 300 mm from the ceiling (minimum permitted height), it might be necessary to temporarily remove some of the suspended ceiling T supports.

2. Position the cassette on the suspended ceiling support rods, and start by tightening the side mounting bolts.



Fig 9

3. Then screw the threaded rods nuts and lock nuts, after having set the cassette level, maintaining a gap of around 10 mm between the metal chassis and the suspended ceiling.

CASSETTE INSTALLATION

1. Side openings are provided for installing separate ducts for outside air intake and treated air distribution to an adjacent room.

2. Use a punch to remove the condensation protection insulation and the pre-punched panels from the openings.

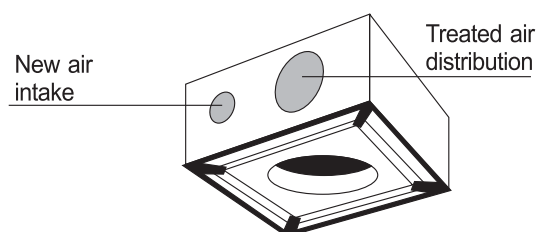

Fig 10

TAKE CARE not to damage the heat exchanger coil located behind the openings.

3. Plug the gaps between the ducts and the opening edge with anti-condensation insulation.
4. Use material which can withstand a continuous operating temperature of 60°C. The ducts can be of the flexible type with a spring core or of corrugated aluminium, covered inside with an insulating material (12 to 25 mm thick glass fibre).
5. When the installation is finished, all the surfaces of the non-insulated ducts must be covered with anti-condensation insulation material (6 mm thick expanded polystyrene or expanded neoprene). Fireproofing classification: M1)

IF THE ABOVE INSTRUCTIONS ARE NOT FOLLOWED, CONDENSATE FLOWS WILL BUILD UP.

6. Distributing air to an adjacent room requires one or two of the corresponding ducts' air distribution flaps to be closed.
7. A decompression grille must be fitted in the partition between the air conditioned room (where the cassette is installed) and the adjacent room.

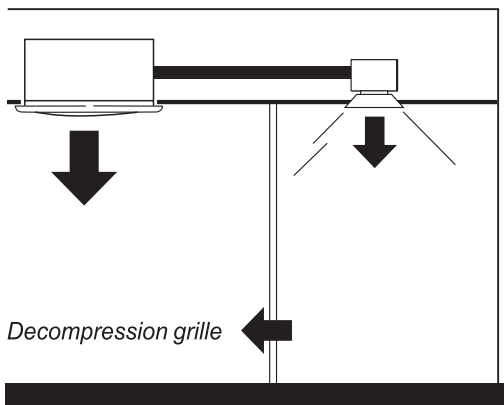

Fig 11

5 CONDENSATE HOSE CONNECTION

CONDENSATE HOSE CONNECTION

1. To ensure effective condensate evacuation, the downward slope must be 1 cm per metre without any restricted or ascending section.

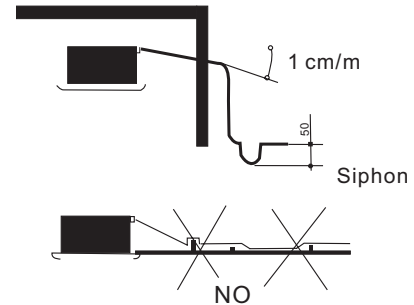

Fig 12

2. The condensate extraction height is limited to a maximum of 0.60 metre (refer to above diagram)
3. For heights above 0.60 m, an auxiliary condensate pump with a level regulator should be installed.

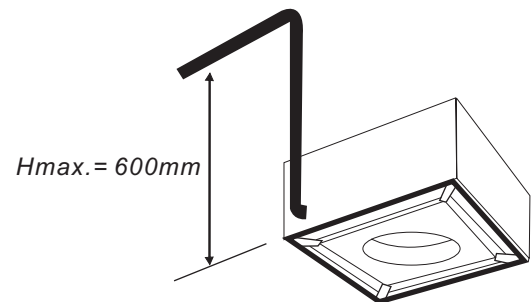

Fig 13

4. Furthermore, a siphon with a height of at least 50 mm must be provided to avoid any unpleasant odours in the room.
5. The condensate evacuation pipe must be heat insulated to a thickness of 5 to 10 mm with insulating material such as polyurethane, propylene or neoprene (Fireproofing classification: M1) to prevent condensation.
6. If several cassettes are installed in the room, the evacuation system can be designed as illustrated below.

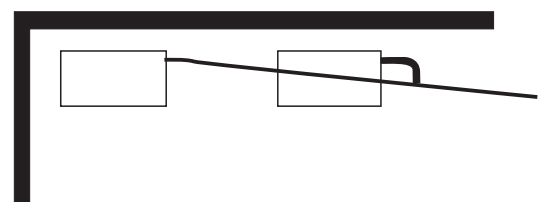

Fig 14

ELECTRICAL CONNECTION BETWEEN INDOOR AND OUTDOOR UNIT

ELECTRICAL REQUIREMENTS

Electrical wiring and connections should be made by qualified electricians and in accordance with local electrical codes and regulation. The air conditioner units must be grounded.

The air conditioner unit must be connected to an adequate power outlet from a separate branch circuit protected by a time delay circuit breaker, as specified on unit's nameplate.

Voltage should not vary beyond $\pm 10\%$ of the rated voltage.

1. To connect the indoor unit to the outdoor unit use the following electrical cables.

Electrical connections:

Capacity	9000 Btu (2500 W) model 12000 Btu (3500 W) model	18000 Btu (5000 W) model
Power input cable	3 wires \times 1.5mm ²	3 wires \times 2.5mm ²
Cable between indoor and outdoor unit	4 wires \times 1.5mm ²	4 wires \times 2.5mm ²

2. Prepare the cable ends for the power input and for the cables between outdoor and indoor units as shown in figure 15a and 15b respectively.
3. Connect the cable ends to the terminals of the indoor and outdoor units, as shown in fig 16.
4. Secure the multiple wire power cable with the cable clamps.

NOTES: The wire color code can be selected by the installer.

TAKE CARE! (Only auto louver models)

Don't touch the air flap by hand anytime. If the flap swings abnormally, please contact qualified personnel for service.

Please check carefully the electrical connection before commissioning, wrong connection may damage the front assy.

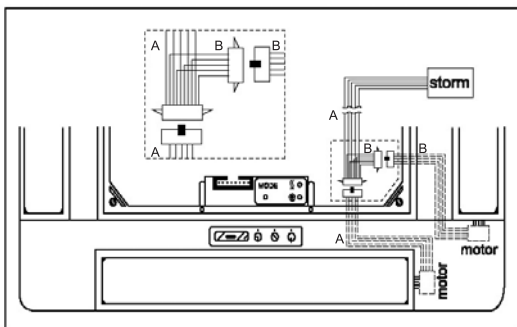

• Power input cable

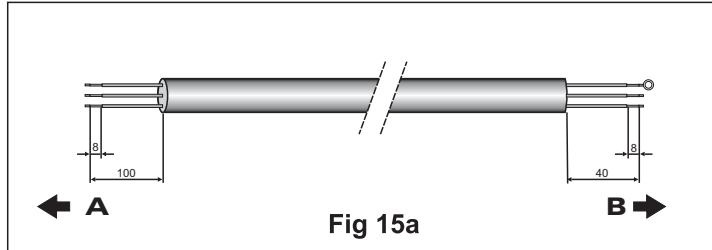

• Cable between indoor and outdoor units

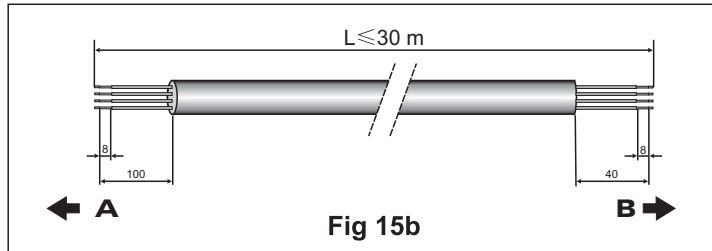

Fig.15 A. OUTDOOR B. INDOOR

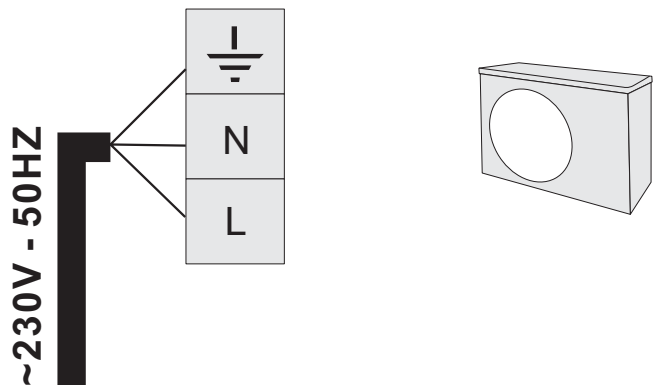
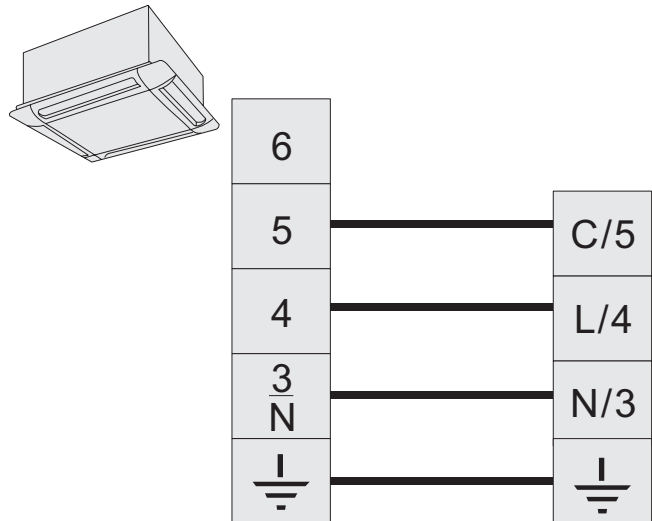

Fig 16

REFRIGERANT TUBING

CONNECT THE INDOOR TO THE OUTDOOR UNIT

The indoor unit contains a small quantity of nitrogen. Do not unscrew the nuts from the unit until you are ready to connect the tubing. The outdoor unit is supplied with sufficient refrigerant charge (R410A). Refer to outdoor unit nameplate.

To prevent crushing, bend tubes using a bending tool.

NOTE: Use refrigeration R410A type copper tubing only.

1. Open the valve cover.
2. Use tubing diameter that corresponds to the tubing diameter of the indoor and outdoor units. Note that the liquid and suction tubes have different diameters. (See tube size, torque tightening table.)
3. Place flare nuts on tube ends before preparing them with a flaring tool. Use the flare nuts that are mounted on the supplied outdoor and indoor units.
4. Connect the all ends of the tubing to the indoor and outdoor units. Notice the sign. All ends should correspond one by one.
5. Insulate each tube separately, and their unions, with at least 6 mm thick of insulation. Wrap the refrigerant tubing, drain hose and electric cables together with a vinyl tape (UV protected).

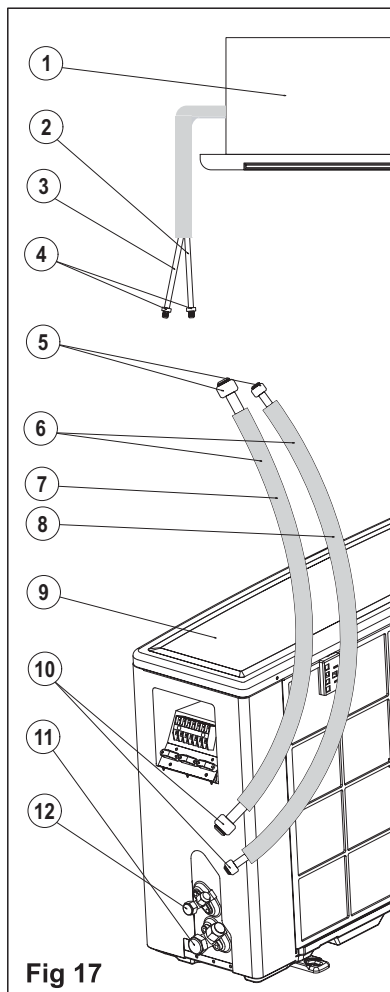

Fig 17

Caution!

When unscrewing the valve caps, do not stand in front of them or the spindles at any time, as the system is under pressure.

- Fig.17
1. INDOOR UNIT
 2. Liquid tube (small dia.)
 3. Suction tube (large dia.)
 4. Plugs
 5. Flare nuts
 6. Tubing between units
 7. Suction tube
 8. Liquid tube
 9. OUTDOOR UNIT
 10. Flare nuts
 11. Suction valve (large)
 12. Liquid valve (small)

Tightening torques of unions and valve caps:

TUBE SIZE	TORQUE
Liquid line 1/4"	15-20 N.M.
Suction line 3/8"	30-35 N.M.
Suction line 1/2"	50-54 N.M.
Suction line 5/8"	75-78 N.M.

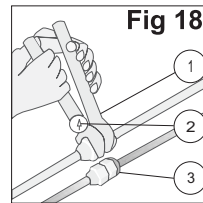

Fig.18
1. Wrench
2. Torque wrench
3. Union

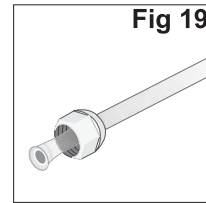

Fig.19
To prevent refrigerant leakage, coat the flared surface with refrigeration oil

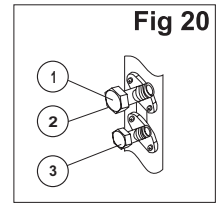

Fig.20
1. Suction valve
2. Service port
3. Liquid valve

AIR DISTRIBUTION MODULE FITTING

1. Carefully unpack the module and fit the clips in the frame corners.

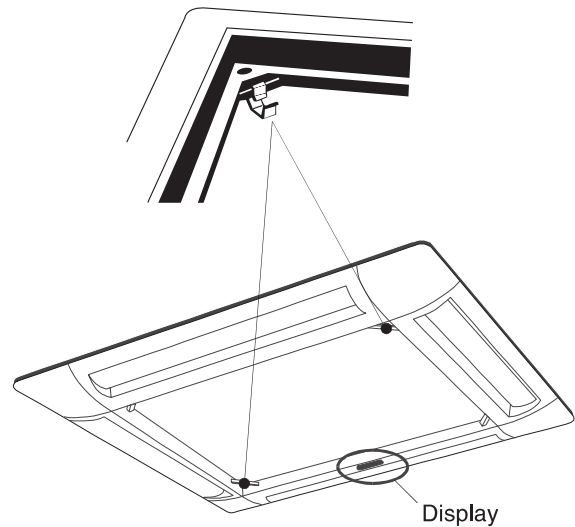

Fig 21

2. Present the frame to the unit, and apply pressure so that the clips engage. Then screw it in place.

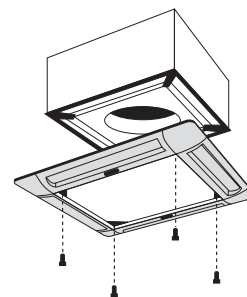

Fig 22

3. The seals are illustrated in the diagram below. They avoid:

- A Air by pass
- B Treated air being distributed into the suspended ceiling space.

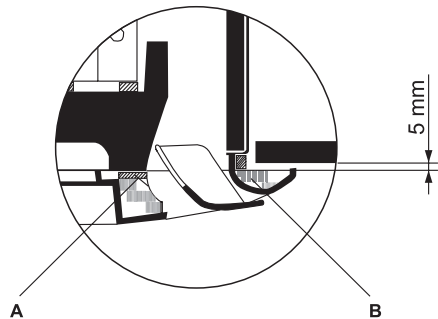

Fig 23

4. After installation, check that the gap between the frame and the suspended ceiling is less than 5 mm.

FILTER INSTALLATION

1. Place the air intake grille hinges in the openings marked A then close the grille with the locks on both sides.

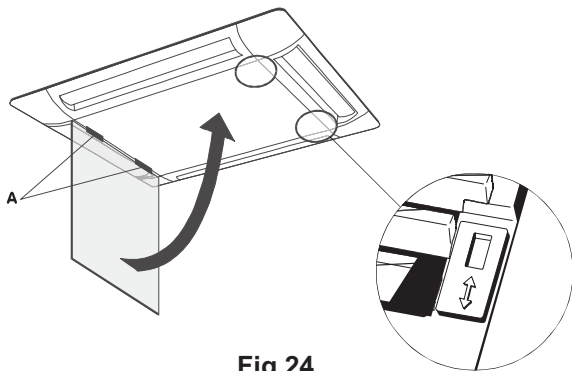

Fig 24

2. Avoid bending the frame with excessive pulling. The frame must be correctly centred in relation to the suspended ceiling and, above all, it must provide an hermetic separation between the air intake and the air distribution.

EVACUATION OF THE REFRIGERATION TUBES AND THE INDOOR UNIT

After connecting the unions of the indoor and outdoor units, purge the air from the tubes and indoor unit as follows:

1. Connect the charging hoses with a push pin to the low side of the charging set and the service port of the suction valve. Be sure to connect the end of the charging hose with the push pin to the service port.
2. Connect the center hose of the charging set to a vacuum pump.
3. Turn on the power switch of the vacuum pump, turn off the high side switch and make sure that the needle in the gauge moves from 0 MPa (0cm Hg) to -0.1 MPa (-76cm Hg). Let the pump run for fifteen minutes.
4. Close the valve of the low side of the charging set and turn off the vacuum pump. Note that the needle in the gauge should not move after approximately five minutes.
5. Not any problem for five minutes, turn on the power switch of the vacuum pump and open the valve of the low side of the charging set.
6. Disconnect the charging hose from the vacuum pump and from the service ports of the suction valve.
7. Tighten the service port caps of suction valve.
8. Redo 1 to 7 for other indoor units.
9. Remove the valve caps from all valves, and open them using a hexagonal Allen wrench.
10. Remount valve caps onto all of the valves.
11. Check for gas leaks from all the connecting position. Test with electronic leak detector or with a sponge immersed with soapy water for bubbles.

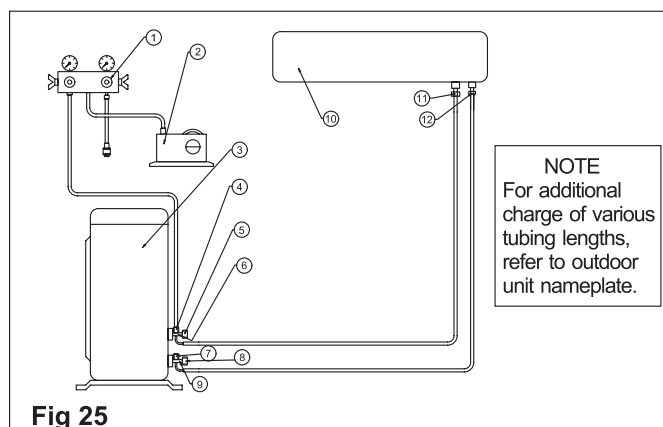

Fig 25

- | | | |
|------------------|-------------------|------------------------------|
| 1. Charging set | 5. Cap | 9. Liquid valve |
| 2. Vacuum pump | 6. Suction valve | 10. INDOOR UNIT |
| 3. OUTDOOR UNIT | 7. Service valve* | 11. Suction flare connection |
| 4. Service valve | 8. Cap | 12. Liquid flare connection |
- *In some models only

8

FINAL TASKS

1. Check all valve caps and ensure that they had been tightened properly. Close the valve cover.
2. Fill gaps on the wall between hole sides and tubing with sealer.
3. Attach wiring and tubing to the wall with clamps where necessary.
4. Operate the unit for no less than 5 minutes at heating or cooling mode.
5. Explain filter removal, cleaning and installation.
6. Operate the air conditioner together with the customer and explain all functions.
7. Give the operating and installation manuals to the customer.

