

INSTALLATION INSTRUCTIONS

ENGLISH

INSTRUCTIONS D'INSTALLATION

FRANÇAIS

INSTALLATIONSANLEITUNG

DEUTSCH

INSTRUCCIONES DE INSTALACION

ESPAÑOL

ISTRUZIONI PER L'INSTALLAZIONE

ITALIANO

РУКОВОДСТВО ПО УСТАНОВКЕ

РУССКИЙ

 **ELECTRA**







INSTALLATION INSTRUCTIONS

ENGLISH

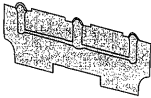
1. ACCESSORIES SUPPLIED WITH AIR CONDITIONER
2. LOCATION OF INDOOR AND OUTDOOR UNITS
3. INSTALLATION/SERVICE TOOLS (ONLY FOR R410A PRODUCT)
4. ELECTRICAL REQUIREMENTS
5. INSTALLATION OF THE INDOOR UNIT
6. CONDENSATE HOSE CONNECTION
7. ELECTRICAL CONNECTIONS BETWEEN INDOOR AND OUTDOOR UNITS
8. REFRIGERANT TUBING
9. FINAL TASKS

The appliance shall not be installed in the laundry.

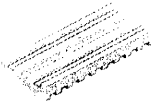
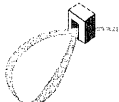
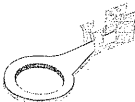
ACCESSORIES SUPPLIED WITH THE AIR CONDITIONER

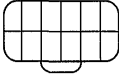
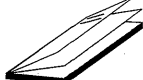
Shape	Name	Qty	Used for
	Mounting rail	1	Wall mounting of indoor unit
	Remote control With batteries	1	Operation of Unit
	Remote control bracket	1	Wall mounting of remote control
	Screwwashers dowels	4	Wall mounting of the indoor unit
	Screws washers dowels	2	Wall mounting of the remote control bracket
	Mounting pads	4	Padding of outdoor unit bottom support
	Cable ties	4	Securing wires in the indoor and outdoor unit
	Cable terminals	2	Securing of grounding wire on the indoor and outdoor unit
	Twin wire cable (for heat pump units)	1	Transmitting
	Air purifying filter (Optional)	2	Cleaning the air
	Operation and installation instructions	2	Users and installers reference

LOCATION OF INDOOR AND OUTDOOR UNITS

Select the location considering the following:

INDOOR UNIT

1. Choose a location which will provide good air circulation. ensure that no objects or furnishings prevent air circulation.
2. Do not install the unit near a heat source or where it will be exposed to direct sunlight.
3. The location must allow convenient electrical draingage and tubing connections.
4. Installation site should provide an easy passage to outdoors.
5. The unit must be mounted on a strong wall that will withstand the generated vibrations.
6. Install the mounting plate as shown.

OUTDOOR UNIT

1. The location must allow easy servicing and provide good air circulation.
2. The unit may be suspended from a wall by a bracket (Optional) or located in a free standing position on the floor (preferably slightly elevated).
3. if the unit is suspended, ensure that the bracket is firmly connected and the wall is strong enough to withstand vibrations.
4. Unit location should not disturb neighbors with noise or exhaust air stream.
5. Place the mounting pads under the unit legs.
6. Install the outdoor unit as shown. Refer to the technical and service manual for allowed distances.
7. When the unit is installed on a wall, install the drain connector hose and drain plug as shown.

Fig.1
1. Bottom of outdoor unit
2. Drain connector

Fig 1

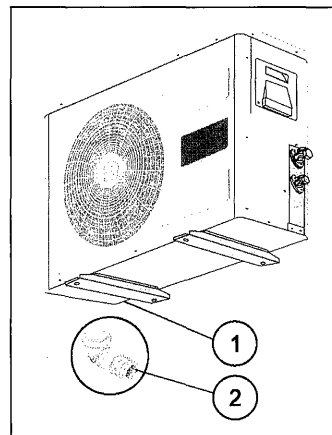
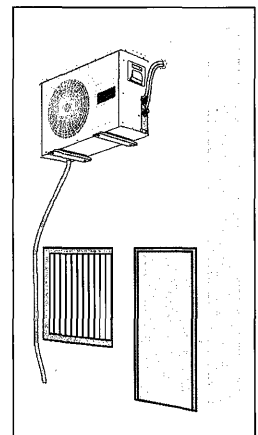

Fig.2
Drain installation Example

Fig 2



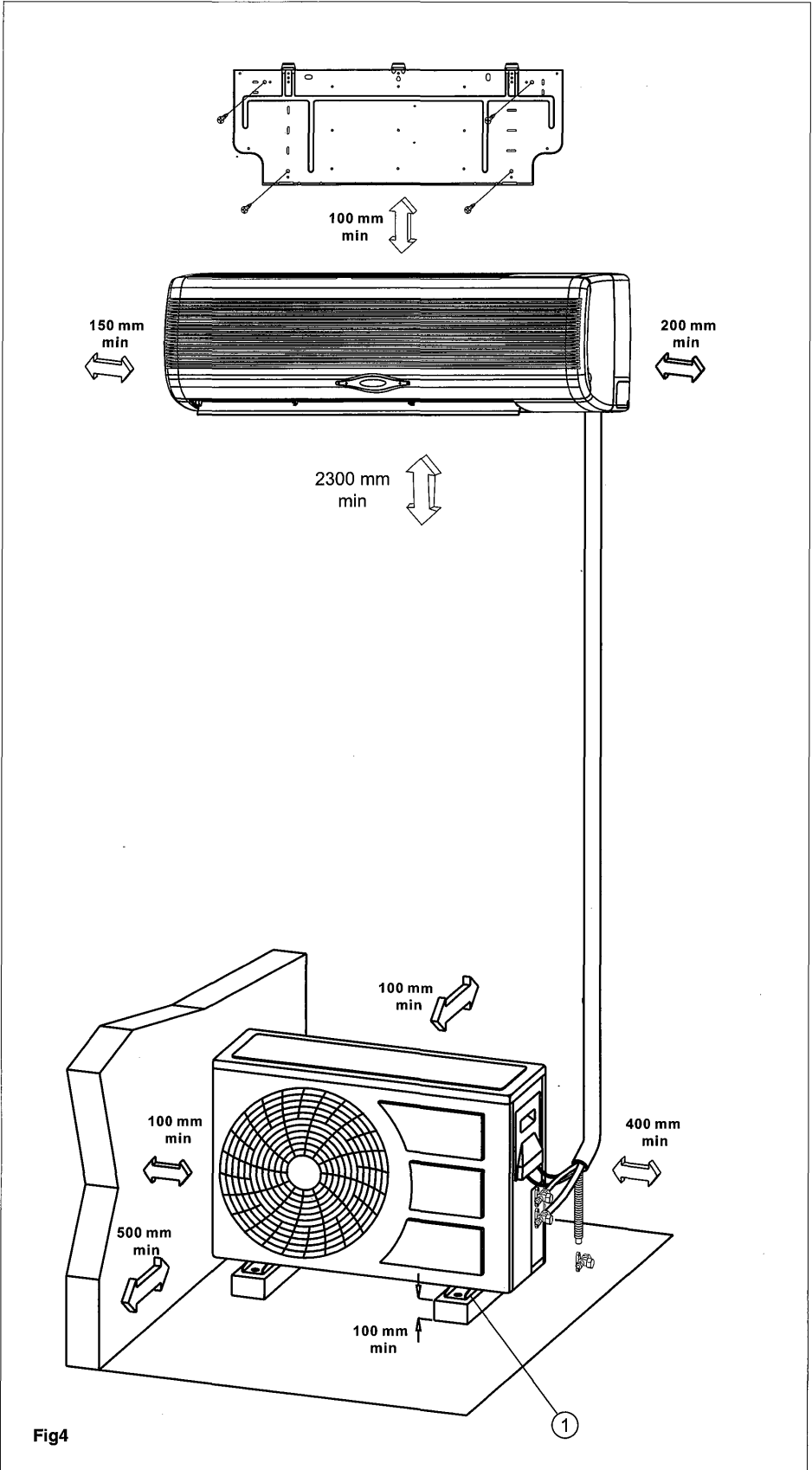

Fig4

Fig.4
1. Mounting pads(x4)

Fig.3
1. To attach
2. To remove

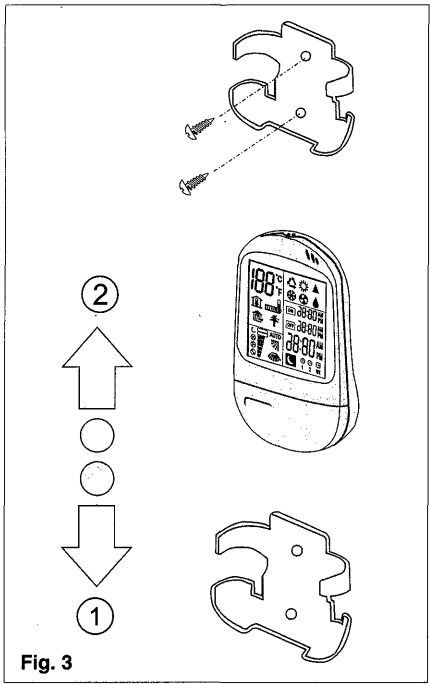

Fig. 3

3

INSTALLATION/SERVICE TOOLS (ONLY FOR R410A PRODUCT)

CAUTION

New Refrigerant Air Conditioner Installation

THIS AIR CONDITIONER ADOPTS THE NEW HFC REFRIGERANT (R410A) WHICH DOES NOT DESTROY OZONE LAYER. R410A refrigerant is apt to be affected by impurities such as water, oxidizing membrane, and oils because the working pressure of R410A refrigerant is approx. 1.6 times of refrigerant R22. Accompanied with the adoption of the new refrigerant, the refrigeration machine oil has also been changed. Therefore, during installation work, be sure that water, dust, former refrigerant, or refrigeration machine oil does not enter into the new type refrigerant R410A air conditioner circuit.







To prevent mixing of refrigerant or refrigerating machine oil, the sizes of connecting sections of charging port on main unit and installation tools are different from those used for the conventional refrigerant units. Accordingly, special tools are required for the new refrigerant (R410A) units. For connecting pipes, use new and clean piping materials with high pressure fittings made for R410A only, so that water and/or dust does not enter. Moreover, do not use the existing piping because there are some problems with pressure fittings and possible impurities in existing piping.

Changes in the product and components

In air conditioners using R410A, in order to prevent any other refrigerant from being accidentally charged, the service port diameter size of the outdoor unit control valve (3 way valve) has been changed. (1/2 UNF 20 threads per inch)

- In order to increase the pressure resisting strength of the refrigerant piping, flare processing diameter and opposing flare nuts sizes have been changed. (for copper pipes with nominal dimensions 1/2 and 5/8)

New tools for R410A

New tools for R410A	Applicable to R22 model		Changes
Gauge manifold	×		As the working pressure is high, it is impossible to measure the working pressure using conventional gauges. In order to prevent any other refrigerant from being charged, the port diameters have been changed.
Charge hose	×		In order to increase pressure resisting strength, hose materials and port sizes have been changed (to 1/2 UNF 20 threads per inch). When purchasing a charge hose, be sure to confirm the port size.
Electronic balance for refrigerant charging	○		As working pressure is high and gasification speed is fast, it is difficult to read the indicated value by means of charging cylinder, as air bubbles occur.
Torque wrench (nominal dia. 1/2, 5/8)	×		The size of opposing flare nuts have been increased. Incidentally, a common wrench is used for nominal diameters 1/4 and 3/8.
Flare tool (clutch type)	○		By increasing the clamp bar's receiving hole size, strength of spring in the tool has been improved.
Gauge for projection adjustment	—		Used when flare is made by using conventional flare tool.
Vacuum pump adapter	○		Connected to conventional vacuum pump. It is necessary to use an adapter to prevent vacuum pump oil from flowing back into the charge hose. The charge hose connecting part has two ports -- one for conventional refrigerant (7/16 UNF 20 threads per inch) and one for R410A. If the vacuum pump oil (mineral) mixes with R410A a sludge may occur and damage the equipment.
Gas leakage detector	×		Exclusive for HFC refrigerant.

- Incidentally, the "refrigerant cylinder" comes with the refrigerant designation (R410A) and protector coating in the U. S's ARI specified rose color (ARI color code: PMS 507).
- Also, the "charge port and packing for refrigerant cylinder" requires 1/2 UNF 20 threads per inch corresponding to the charge hose's port size.

4

ELECTRICAL REQUIREMENTS

Electrical wiring and connections should be made by qualified electricians and in accordance with local electrical codes and regulations. The air conditioner units must be grounded.

The air conditioner unit must be connected to an adequate power outlet from a separate branch circuit protected by a time delay circuit breaker, as specified on unit's nameplate.

Voltage should not vary beyond $\pm 10\%$ of the rated voltage.

5

INSTALLATION OF THE INDOOR UNIT

REMOVAL AND INSTALLATION OF THE FRONT PANEL

1. Open the front panel.
2. Open the terminal cover
3. After installation of the wires, replace the terminal cover and close the grille.

Fig.5
1. Lift the grille
2. Screw
3. Terminal

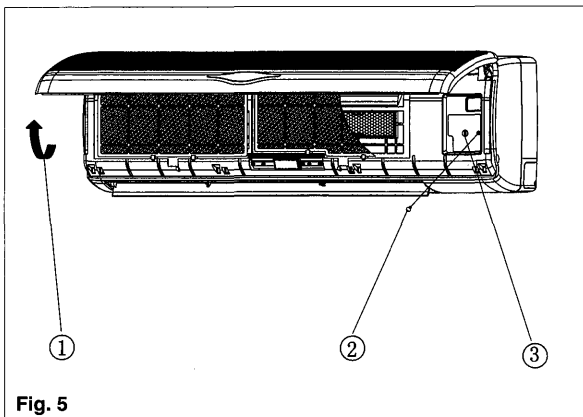

REFRIGERATION TUBE ROUTING

1. There are five possible routes for installing the refrigeration tube as shown.
2. For route (6), cut the bottom notch in the rear.
3. For routes (4) or (7), cut the side notches in the rear and in the front panel.

Fig.6
1. Front
2. Rear
3. Rear outlet
4. Lefthand outlet
5. Lefthand rear outlet
6. Bottom outlet
7. Righthand outlet

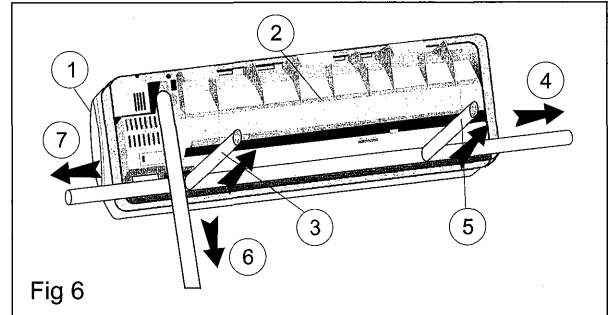

INSTALLATION OF THE MOUNTING PLATE

1. Figure 9 shows the location of the mounting plate relative to the unit size. Refer to one of the drawings, according to your unit length (marked in square).
2. Locate the mounting plate as shown on the wall in a horizontal position, using a spirit level.
3. Mark the position of the four mounting holes on the wall and drill four holes to accommodate the dowels.
4. Mount the mounting plate on to the wall by the four screws. Ensure screws are tightened properly.

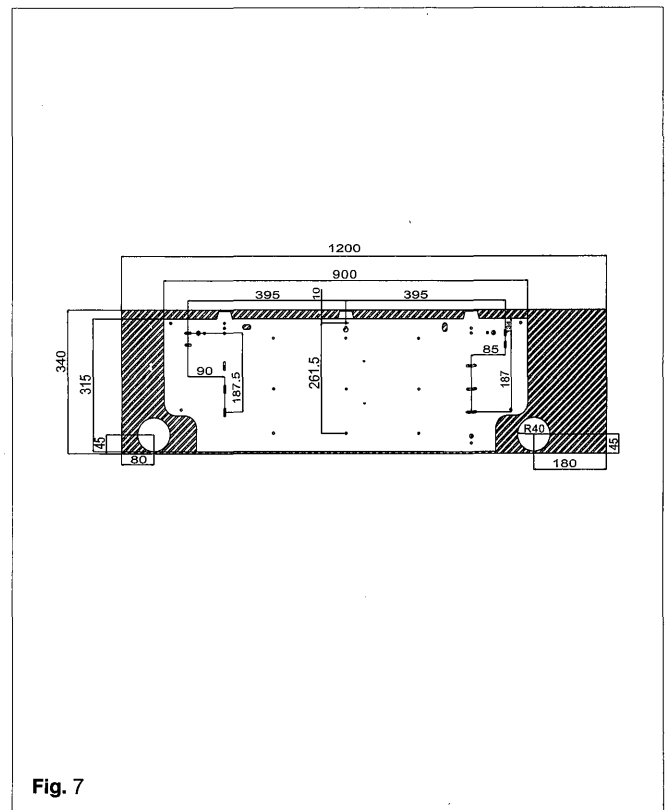

Fig. 7

CONDENSATE HOSE CONNECTION

PENETRATION OF WALL FOR TUBING

1. Mark the location of the hole on either side of the mounting plate as shown, and drill it at a 5° downward angle, as shown.
2. The hole is drilled at an angle, to prevent condensed or rain water from penetrating back into the room
3. Trim the hole in the wall with a ϕ 80 mm commercial plastic tube.

Fig. 8

- A. OUTDOOR SIDE 1. Drill 80 mm
B. INDOOR SIDE 2. Wall

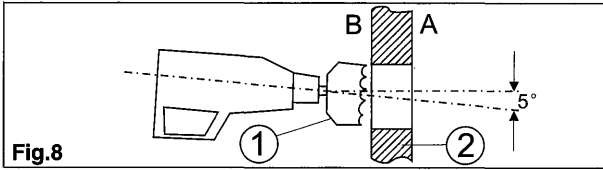

SUSPENDING AND RELEASING THE UNIT FROM THE MOUNTING PLATE

1. Make sure that the refrigerant tubes, electric cables and condensate water hose are well insulated with closed cell rubber based insulating tubes (6 mm thickness), are wrapped together with UV stabilized non-adhesive plastic tape, and are passed through the hole in the wall.
2. Hang the indoor unit on the two hooks that are located near the top edge of the mounting plate.
3. Press the lower part of the indoor unit against the mounting plate until the catches snap into the slots and lock the indoor unit to the mounting plate.
4. Check the installation by pulling the unit towards you.
5. To release the unit from the mounting plate, lift up the unit and then pull the unit towards you, to ensure that the hooks are locked.

Fig. 9

1. Indoor unit 3. Top hooks
2. Snap catches 4. Bottom hooks

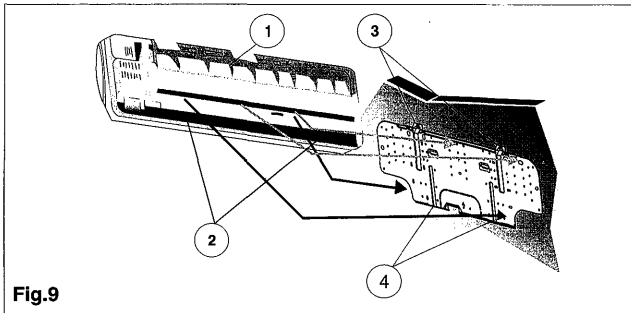
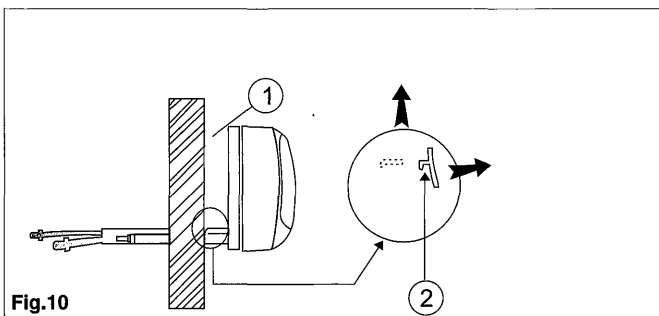

Fig. 10

1. Mounting plate
2. Lower hook



1. Attach the condensate drain hose to the corrugated hose in the rear groove of the indoor unit.

2. Wrap the drain hose together with the refrigerant tubes and electrical cables.

3. Ensure that the condensate drain hose is at all points installed in a downward slope manner.

Fig. 11

1. drain hose
2. Clamp
3. Downward slope

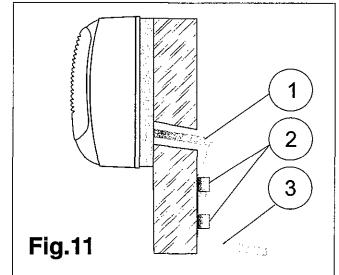

Fig. 12

1. Trap
2. U-bend
3. End immersed in water

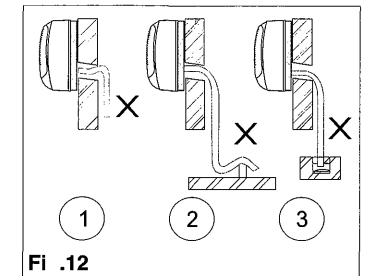
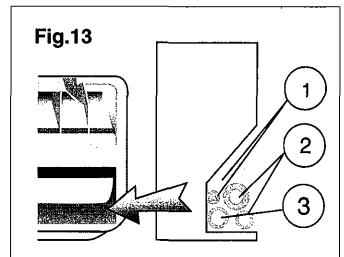

Fig. 13

1. Electric cable
2. Refrigerant tubing
3. Condensate drain hose



4. When installing the drain hose avoid traps and U-bends. The end of the drain hose should not be immersed in water.

5. For a lefthand outlet, lay the drain hose on the bottom of the indoor unit rear groove.

Fig. 14

1. Vent
2. Downward drain
3. Water drain hose

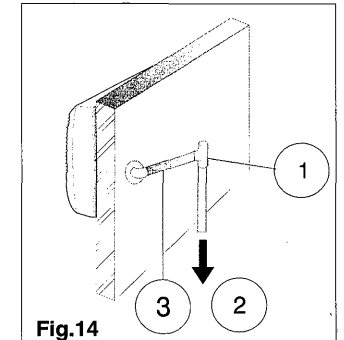

6. When the installation location requires long horizontal sections, a vent must be provided at the top of the hose to prevent overflow of the unit drain pan.

7. Upon completing the installation, test the water drain by pouring at least two liters of water into the unit drainpan. Check that the water drains off.

ELECTRICAL CONNECTIONS BETWEEN INDOOR AND OUTDOOR UNITS

1. To connect the indoor unit to the outdoor unit use the following electrical cables, protected for outdoor use:

SINGLE PHASE MODELS(see Fig.16a)

Cooling and heating model:

Model	Maximum Current	Circuit Breaker
WNG25	16 A	20 A
WNG30	20 A	25A

Important:

Wire size should be according to local electrical codes and regulation

Twin wire cable

2 wires x 0.5 mm² - for low voltage

For units above 8.0KW(see fig.16b)

The main power supply(5)will be connected to the outdoor unit.

An all-pole disconnection switch having a contact separation of at least 3mm in all poles should be connected in fixed wiring.

THREE PHASE MODELS(see Fig16.16c)

The main power supply electrical cable must be of H05VV-K5G type and contain 6×2.5mm² conductors, connected to a thermally protected circuit breaker3 x 12.5A.

2. Prepare inter-unit cable ends for connections
3. Connect the cable ends to the terminals of the indoor and outdoor units, as shown in fig.16a. fig.16b.and fig.16c.
- Be sure to match the colored wires with the numbers shown on the indoor and outdoor unit terminal boards.
4. connect the yellow/green ground wire to the ground terminal screw.
5. Secure the multiple wire power cable with the cable clamps.
6. Fasten the twin wire cable to the power cable with cable ties.

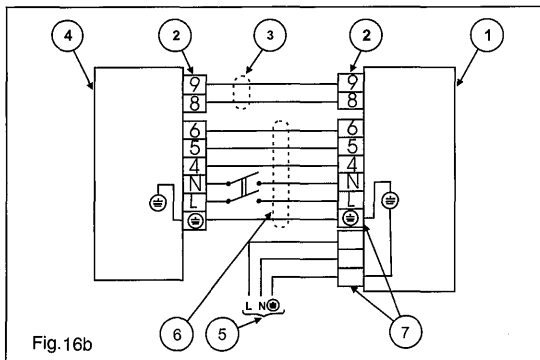

Fig.16a

- 1.Outdoor unit
- 2.Terminal board
- 3.Control cable
4. Indoor unit
- 5.Power supply
- 6.Electrical interconnecting cable
- 7.Terminal board male/female

Fig.15

- 1.Terminals
2. Cover
3. Cable tie

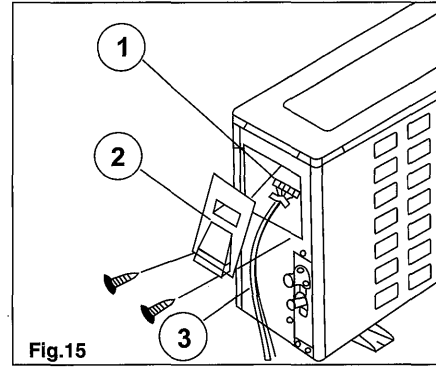

Fig.15

NOTES:

1. The wire color code can be selected by the installer.
2. Wires leading to outdoor unit twin wire terminal (9). must be in a separate twin wire cable, otherwise the electronic controls will be subjected to operational malfunctions.
3. For cooling only model, Wire(5) should not be connected to terminal No.5
4. In some models the twin wire cable is factory-connected to the indoor unit.

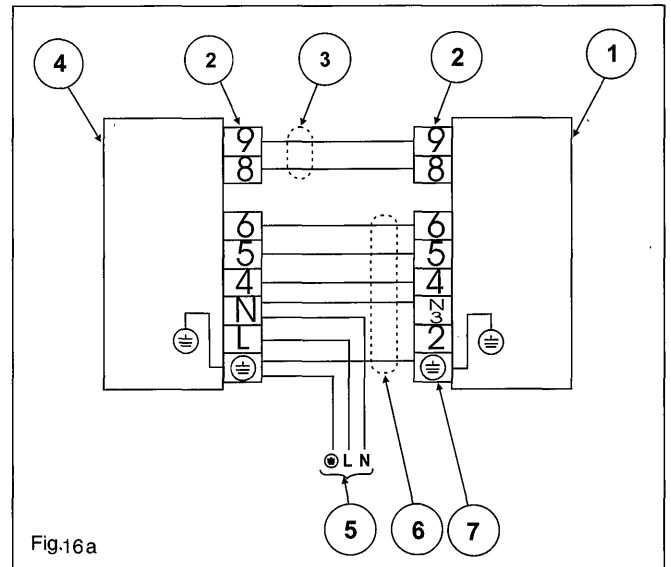

Fig.16a

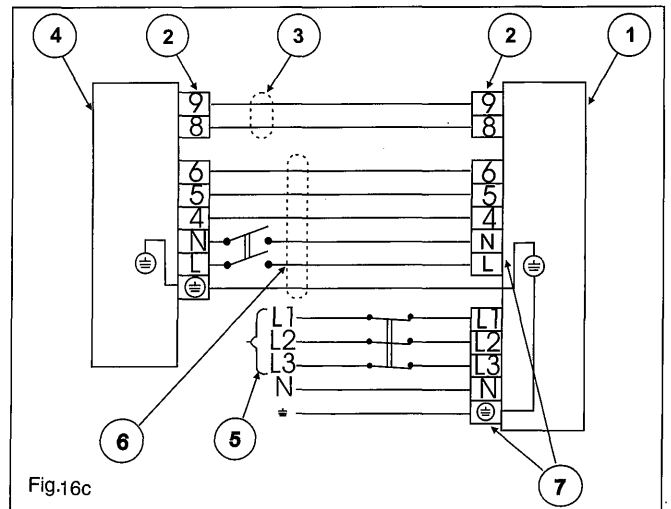

Fig.16c

REFRIGERANT TUBING

CONNECT THE INDOOR TO THE OUTDOOR UNIT

The indoor unit contains a small quantity of refrigerant. Do not unscrew the nuts from the unit until you are ready to connect the tubing. The outdoor unit is supplied with sufficient refrigerant charge. Refer to outdoor unit nameplate.

To prevent crushing, bend tubes using a bending tool.

NOTE: Use refrigeration type copper tubing only.

1. Use tubing diameter that corresponds to the tubing diameter of the indoor and outdoor units. Note that the liquid and suction tubes have different diameters. (See tube size, torque tightening table.)
2. Place flare nuts on tube ends before preparing them with a flaring tool. Use the flare nuts that are mounted on the supplied outdoor and indoor units.
3. Connect the four ends of the tubing to the indoor and outdoor units.
4. Insulate each tube separately, and their unions, with at least 6 mm. of insulation. Wrap the refrigerant tubing, drain hose and electric cables together with a vinyl tape (UV protected).

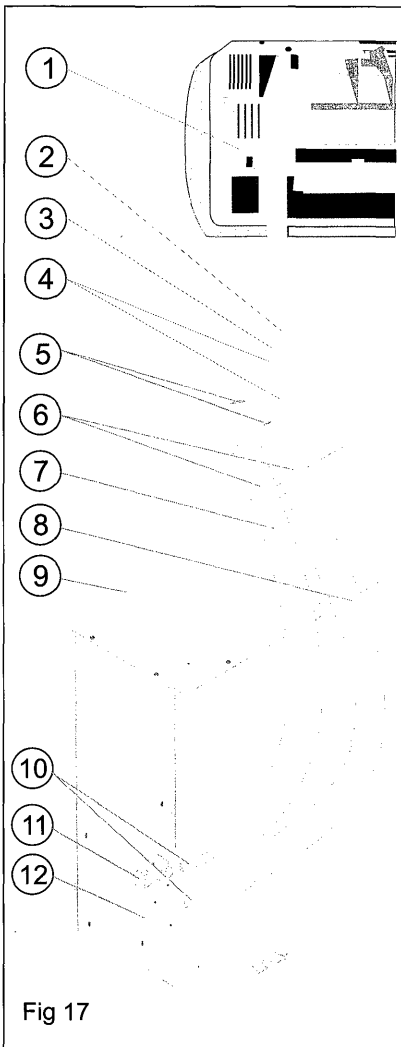

Fig 17

Caution!
When unscrewing the valve caps, do not stand in front of them or the spindles at any time, as the system is under pressure.

- Fig.17
- 1.INDOOR UNIT
 - Liquid tube (small dia.)
 - Suction tube (large dia.)
 - Plugs
 - Flare nuts
 - Tubing between units
 - Suction tube
 - Liquid tube
 - OUTDOOR UNIT
 - Flare nuts
 - Suction valve (larger)
 - Liquid valve (small)

Tightening torques of unions and valve caps:

TUBE SIZE	TORQUE
Liquid line 3/8"	30-25 N.M.
Suction line 1/2"	50-54 N.M.
Suction line 5/8"	75-78 N.M.
Suction line 3/4"	80-100 N.M.

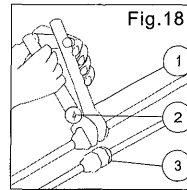

Fig.18
1.Wrench
2.Torque wrench
3.Union

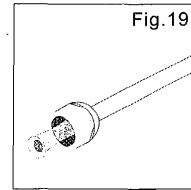

Fig.19
To prevent refrigerant leakage, coat the flared surface with refrigeration oil

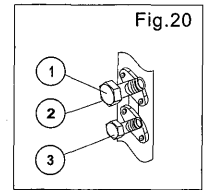

Fig.20
1.Suction valve
2.Service port
3.Liquid valve

EVACUATION OF THE REFRIGERATION TUBES AND THE INDOOR UNIT

After connecting the unions of the indoor and outdoor units, purge the air from the tubes and indoor unit as follows:

1. Connect the charging hoses with a push pin to the low and high sides of the charging set and the service port of the suction and liquid valves. Be sure to connect the end of the charging hose with the push pin to the service port.
2. Connect the center hose of the charging set to a vacuum pump
3. Turn on the power switch of the vacuum pump and make sure that the needle in the gauge moves from 0MPa(0cm Hg) to -0.1 MPa (-76cm Hg). Let the pump run for fifteen minutes.
4. Close the valves of both the low and high sides of the charging set and turn off the vacuum pump. Note that the needle in the gauge should not move after approximately five minutes.
5. Disconnect the charging hose from the vacuum pump and from the service ports of the suction and liquid valves.
6. Tighten the service port caps of both suction and liquid valves.
7. Remove the valve caps from both valves, and open them using a hexagonal Allen wrench.
8. Remount valve caps onto both of the valves.
9. Check for gas leaks from the four unions and from the valve caps. Text with electronic leak detector or with a sponge immersed in soapy water for bubbles.

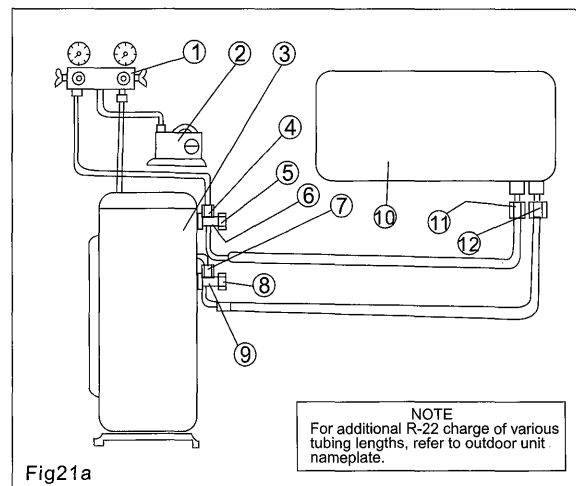

Fig21a

NOTE
For additional R-22 charge of various tubing lengths, refer to outdoor unit nameplate.

- Fig.21a
- 1.Charging set
 - 2.Vacuum pump
 - OUTDOOR UNIT
 - Service valve
 - Cap
 - Suction valve
 - Service valve*
 - Cap
 - Liquid valve
 - INDOOR UNIT
 - Suction flare connection
 - Liquid flare connection
- *In some models only

9

FINAL TASKS

1. Replace all valve caps and ensure that they are tightened properly.
2. Fill gaps on the wall between hole sides and tubing with sealer.
3. Attach wiring and tubing to the wall with clamps where necessary.
4. Operate the air conditioner together with the customer and explain all functions.
5. Explain filter removal, cleaning and installation.
6. Give the operating and installation manuals to the customer.