

**ENGLISH**

**Required tools for Installation Works**

- |   |                      |                                 |
|---|----------------------|---------------------------------|
| 1. Screw driver                             | 7. Knife             | 13. Torque wrench               |
| 2. Electric drill, hole core drill (∅60 mm) | 8. Gas leak detector | 18 N • m (1.8 kgf.m)            |
| 3. Hexagonal wrench                         | 9. Measuring tape    | 35 N • m (3.5 kgf.m)            |
| 4. Spanner                                  | 10. Thermometer      | 55 N • m (5.5 kgf.m)            |
| 5. Pipe cutter                              | 11. Megameter        | 14. Vacuum pump                 |
| 6. Reamer                                   | 12. Multimeter       | 15. Gauge manifold (for R-410A) |

**SAFETY PRECAUTIONS**

- Read the following "SAFETY PRECAUTIONS" carefully before installation.
- Electrical work must be installed by a licensed electrician. Be sure to Use the correct rating of the power plug and main circuit for the model to be installed.
- The caution items stated here must be followed because these important contents are related to safety. The meaning if each indication used is as below. Incorrect installation due to ignoring of the instruction will cause harm or damage, and the seriousness is classified by the following indications.

**WARNING** This indication shows the possibility of causing death or serious injury.

The items to be followed are classified by the symbols:  
 Symbol with background white denotes item that is PROHIBITED from doing.

- Carry out test running to confirm that no abnormality occurs after the installation. Then, explain to user the operation, care and maintenance as stated in instructions. Please remind the customer to keep the operating instructions for future reference.

**WARNING**

- 1) Use qualified installer and follow careful this instructions. Otherwise it will cause electrical shock, water leakage, or esthetic problem.
- 2) Install at a strong and firm location which is able to withstand the set's weight. If the strength is not enough or installation is not properly done, the set will drop and cause injury.
- 3) For electrical work, follow the local national wiring standard, regulation and this installation instruction. An independent circuit and single outlet must be used. If electrical circuit capacity is not enough or defect found in electrical work, it will cause electrical shock or fire.
- 4) Use the specified cable and connect tightly for indoor/outdoor connection. Connect tightly and clamp the cable so that no external force will be acted on the terminal. If connection or fixing is not perfect, it will cause heat-up or fire at the connection.
- 5) Wire routing must be properly arranged so that control board cover is fixed properly. If control board cover is not fixed perfectly, it will cause heat-up at connection point of terminal, fire or electrical shock.
- 6) When carrying out piping connection, take care not to let air substances other than the specified refrigerant go into refrigeration cycle. Otherwise, it will cause lower capacity, abnormal high pressure in the refrigeration cycle, explosion and injury.
- 7) Do not damage or use unspecified power supply cord. Otherwise, it will cause fire or electrical shock.
- 8) Do not modify the length of the power supply cord or use of the extension cord, and do not share the single outlet with other electrical appliances. Otherwise, it will cause fire or electrical shock.
- 9) This equipment must be earthed. It may cause electrical shock if grounding is not perfect.
- 10) Do not install the unit at place where leakage of flammable gas may occur. In case gas leaks and accumulates at surrounding of the unit, it may cause fire.
- 11) Carry out drainage piping as mentioned in installation instructions. If drainage is not perfect, water may enter the room and damage the furniture.

**ATTENTION**

- 1) Selection of the installation location. Select a installation location which is rigid and strong enough to support or hold the unit, and select a location for easy maintenance.
- 2) Power supply connection to the room air conditioner. Connect the power supply cord of the room air conditioner to the mains using one of the following method. Power supply point shall be the place where there is ease for access for the power disconnection in case of emergency. In some countries, permanent connection of this room air conditioner to the power supply is prohibited.
  - 1) Power supply connection to the receptacle using a power plug.
  - 2) Use an approved 10A power plug with earth pin for 2.1-3.6kW and 15A for 4.0kW for the connection to the receptacle. In some countries, permanent connection of this room air conditioner to the power supply is prohibited. Use an approved 10A circuit breaker for 2.1-3.6kW and 15A for 4.0kW for the permanent connection. It must be a double pole switch with a minimum 3mm contact gap.
- 3) Do not release refrigerant.
- 4) Do not release refrigerant during piping work for installation, reinstallation and during repairing a refrigeration parts. Take care of the liquid refrigerant. It may cause frostbite.
- 4) Installation work. It may need two people to carry out the installation work.
- 5) Do not install this appliance in a laundry room or other location where water may drip from the ceiling, etc.

**NOTE**

This manual is for single split applications. For multi split applications please use installation manual supplied within outdoor unit package.

**INSTALLATION/SERVICE TOOLS (ONLY FOR R410A PRODUCT)**

**CAUTION**

**New Refrigerant Air Conditioner Installation**  
**THIS AIR CONDITIONER ADOPTS THE NEW HFC REFRIGERANT (R410A) WHICH DOES NOT DESTROY OZONE LAYER.** R410A refrigerant is apt to be affected by impurities such as water, oxidizing membrane, and oils because the working pressure of R410A refrigerant is approx. 1.6 times of refrigerant R22. Accompanied with the adoption of the new refrigerant, the refrigeration machine oil has also been changed. Therefore, during installation work, be sure that water, dust, former refrigerant, or refrigeration machine oil does not enter into the new type refrigerant R410A air conditioner circuit. To prevent mixing of refrigerant or refrigerating machine oil, the sizes of connecting sections of charging port on main unit and installation tools are different from those used for the conventional refrigerant units. Accordingly, special tools are required for the new refrigerant (R410A) units. For connecting pipes, use new and clean piping materials with high pressure fittings made for R410A only so that water and/or dust does not enter. Moreover, do not use the existing piping because there are some problems with pressure fittings and possible impurities in existing piping.  
**Changes in the product and components**  
 In air conditioners using R410A, in order to prevent any other refrigerant from being accidentally charged, the service port diameter size of the outdoor unit control valve (3 way valve) has been changed. (1/2 UNF 20 threads per inch)  
 In order to increase the pressure resisting strength of the refrigerant piping, flare processing diameter and opposing flare nuts sizes have been changed. (For copper pipes with nominal dimensions 1/2 and 3/8)

New tools for R410A	Applicable to R22 model	Changes
Gauge manifold	X	As the working pressure is high, it is impossible to measure the working pressure using conventional gauges. In order to prevent any other refrigerant from being charged, the port diameters have been changed.
Charge hose	X	In order to increase pressure resisting strength, hose materials and port sizes have been changed (to 1/2 UNF 20 threads per inch). When purchasing a charge hose, be sure to confirm the port size.
Electronic balance for refrigerant charging	O	As working pressure is high and gasification speed is fast, it is difficult to read the indicated value by means of charging cylinder, as air bubbles occur.
Torque wrench (nominal dia. 1/2, 3/8)	X	The size of opposing flare nuts have been increased. Incidentally, a common wrench is used for nominal diameters 1/4 and 3/8.
Flare tool (clutch type)	O	By increasing the clamp bar's receiving hole size, strength of spring in the tool has been improved.
Gauge for projection adjustment	—	Used when flare is made by using conventional flare tool.
Vacuum pump adapter	O	Connected to conventional vacuum pump. It is necessary to use an adapter to prevent vacuum pump oil from flowing back into the charge hose. The charge hose connecting part has two ports - one for conventional refrigerant (7/16 UNF 20 threads per inch) and one for R410A. If the vacuum pump oil (mineral) mixes with R410A a sludge may occur and damage the equipment.
Gas leakage detector	X	Exclusive for HFC refrigerant.

- Incidentally, the "refrigerant cylinder" comes with the refrigerant designation (R410A) and protector coating in the U.S.'s ARI specified rose color (ARI color code: PMS 507).
- Also, the "charge port and packing for refrigerant cylinder" requires 1/2 UNF 20 threads per inch corresponding to the charge hose's port size.

**Attached accessories.**

No.	Accessories part	Qty.	No.	Accessories part	Qty.
01	Mounting plate	1	07	Screws washer dowels	4
02	Remote control with batteries	1	08	Screws dowels	2
03	Remote control bracket	1	09	Outdoor unit drain connector	1
04	Mounting pads	4	10	Cable ties	4
05	Cable terminals	1	11	Power input cable (Optional)	1
06	Air purifying filter (Optional)	2	12	Remote control operation manual	3

**SELECT THE BEST LOCATION**

**INDOOR UNIT**

- There should not be any heat source or steam near the unit.
- There should not be any obstacles blocking the air circulation.
- A place where air circulation in the room is good.
- A place where drainage can be easily done.
- A place where noise prevention is taken into consideration.
- Do not install the unit near the door way.
- Ensure the spaces indicated by arrows from the wall, ceiling, fence or other obstacles.
- Recommended installation height for indoor unit shall be at least 2.3m.

**OUTDOOR UNIT**

- If an awning is built over the unit to prevent direct sunlight or rain, be careful that heat radiation from the condenser is not obstructed.
- There should not be any animal or plant which could be affected by hot air discharged.
- Keep the spaces indicated by arrows from wall, ceiling, fence or other obstacles.
- Do not place any obstacles which may cause a short circuit of the discharged air.
- If piping length is over 10m, additional refrigerant should be added as shown in the outdoor unit table.

**Indoor/Outdoor Unit Installation Diagram**

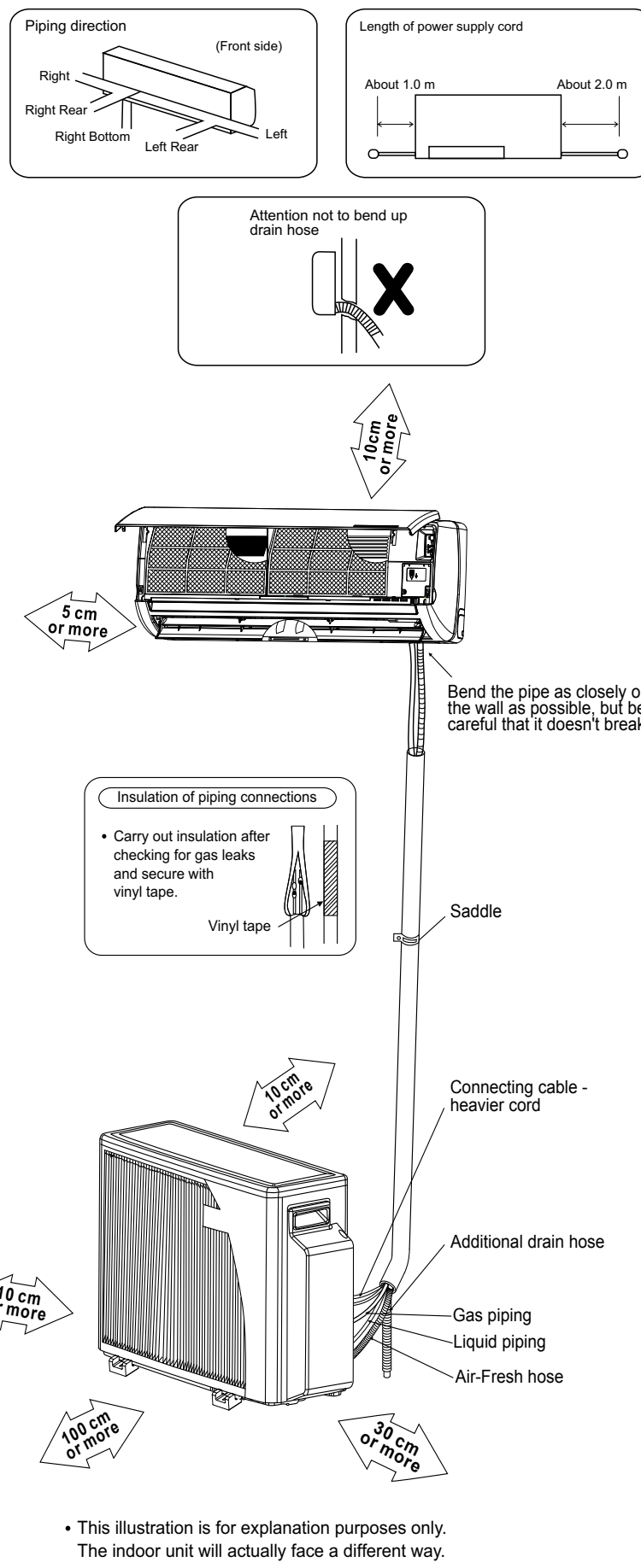

**INDOOR UNIT**

**1 SELECT THE BEST LOCATION**  
(Refer to "Select the best location" section)

**2 HOW TO FIX INSTALLATION PLATE**

The mounting wall is strong and solid enough to prevent it from the vibration.

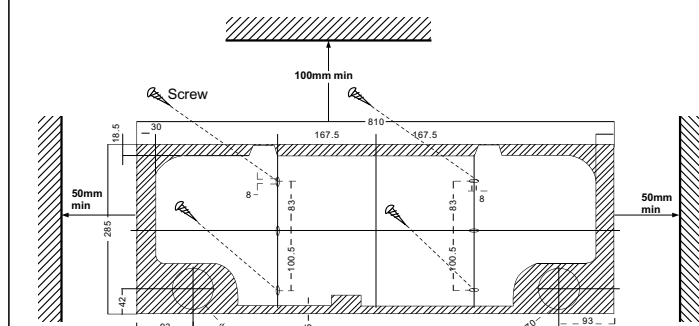

The edge of installation carton board should be at more than 50mm at right and left of the wall.

1. Locate the mounting plate on the wall in a horizontal position.
2. Mark the position of the four mounting holes on the wall and drill four holes to accommodate the dowels.
3. Mount the mounting plate on the wall by the four screws. Ensure screws are tightened properly.
4. Mark the location of the piping hole on either side of the mounting plate as shown.
5. The piping hole is drilled at a 5° down-ward angle to prevent condensed or rain water from penetrating back into the room.
6. Trim the hole in the wall with a ∅70mm commercial plastic tube.

**3 INDOOR UNIT INSTALLATION**

**1.FOR THE RIGHT REAR PIPING**

- Pull out the Indoor piping
- Install the Indoor Unit
- Secure the Indoor Unit

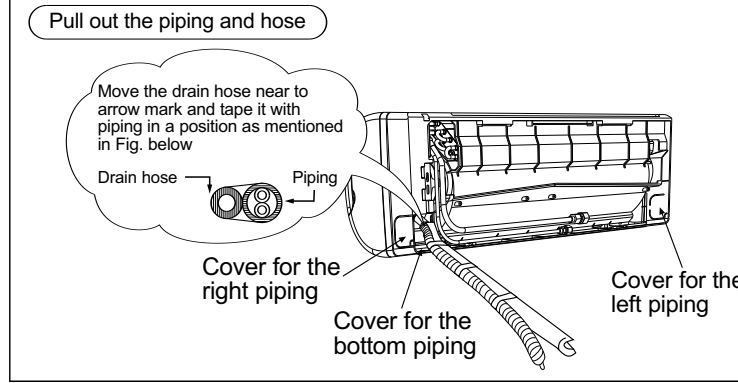

**2. FOR THE RIGHT AND RIGHT BOTTOM PIPING**

- Pull out the Indoor piping
- Install the Indoor Unit
- Install the connecting cable and pipe
- Secure the Indoor Unit

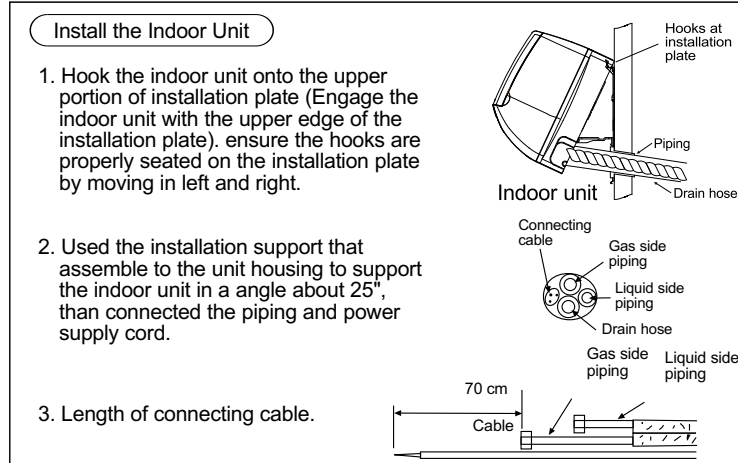

**Secure the Indoor Unit**

1. Tape the extra power supply cord in a bundle and keep it behind the chassis.
  - Ensure that the power supply cord is not clamped in between the unit's hook (2 positions) and installation plate.
2. Press the lower left and right side of the unit against the installation plate until hooks engages with their slots (sound click).

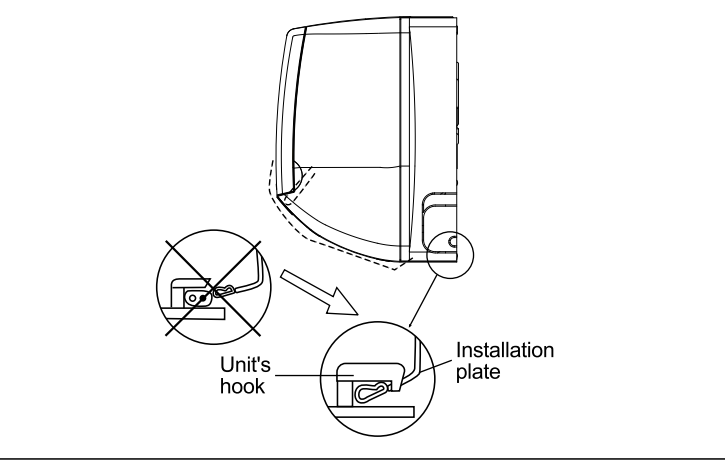

To take out the unit, pull the marking at the bottom unit, and pull it slightly towards you to disengage the hooks from the unit.

**3.FOR THE LEFT**

- Collaborate the piping
- Install the Indoor Unit
- Secure the Indoor Unit

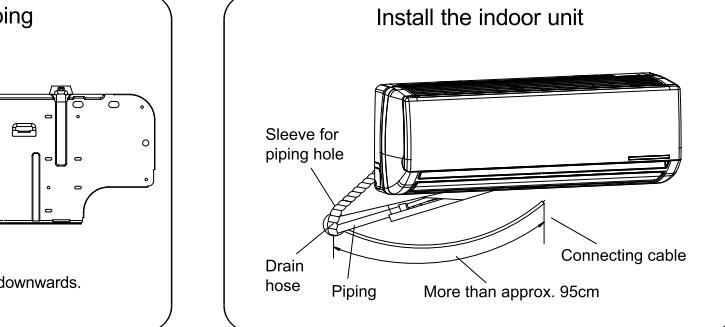
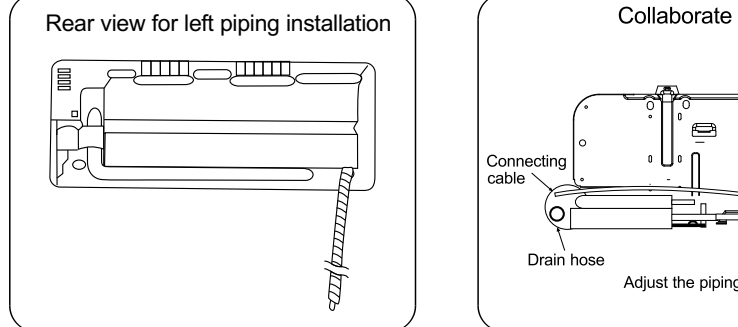

**4 INSTALLATION OF AIR PURIFYING FILTERS**

1. Open the grille.
2. Remove the air filters.
3. Put air purifying filter into place as shown in illustration at right.

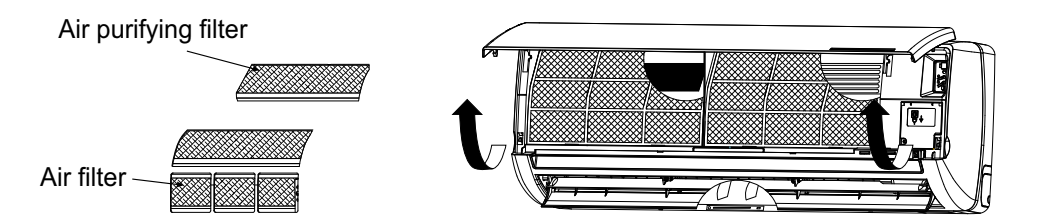

**1 SELECT THE BEST LOCATION**  
(Refer to "Select the best location" section)

**2 INSTALL THE OUTDOOR UNIT**

- After selecting the best location, start installation according to Indoor/Outdoor Unit Installation Diagram.
1. Fix the unit on concrete or rigid frame firmly and horizontally by bolt nut (∅8 mm).
  2. When installing at roof, please consider strong wind and earthquake. Please fasten the installation stand firmly with bolt or nails.

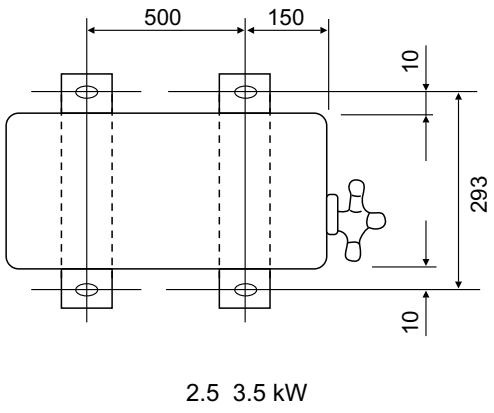

**3 CONNECTING THE PIPING**

**CUTTING AND FLARING THE PIPING**

1. Please cut using pipe cutter and then remove the burrs.
2. Remove the burrs by using reamer. If burrs is not removed, gas leakage may be caused. Turn the piping end down to avoid the metal powder entering the pipe.
3. Please make flare after inserting the flare nut onto the copper pipes.
4. If you used the piping kit, you could connect the piping directness and no need do the procedure 1 to 3.

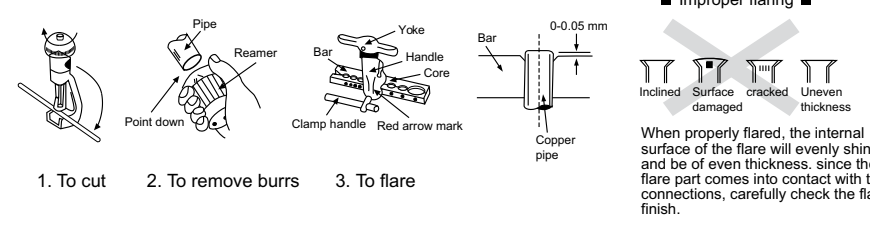

**Connecting The Piping To Indoor Unit**

- Connect the piping
  - Align the center of piping and sufficiently tighten the flare nut with fingers.
  - Further tighten the flare nut with torque wrench in specified torque as stated in the table.
- | Model      | Gas            | Liquid         |
|------------|----------------|----------------|
| 2.5-3.5 kW | 3/8" (∅9.52mm) | 1/4" (∅6.35mm) |

**Connecting the Piping To Outdoor Unit**

Align center of piping to valves and then tighten with torque wrench to the specified torque as stated in the table.

**4 EVACUATION OF THE REFRIGERATION TUBES AND THE INDOOR UNIT**

- After connection the unions of the indoor and outdoor units, purge the air from the tubes and indoor unit as follows:
1. Connect the charging hoses with a push pin to the low and high sides of the charging set and the service port of the suction and liquid valves. Be sure to connect the end of the charging hose with the push pin to the service port.
  2. Connect the center hose of the charging set to a vacuum pump.
  3. Turn on the power switch of the vacuum pump and make sure that the needle in the gauge moves from 0MPa (0cm Hg) to -0.1 MPa (-76cm Hg). Let the pump run for fifteen minutes.
  4. Close the valves of both the low and high sides of the charging set and turn off the vacuum pump. Note that the needle in the gauge should not move after approximately five minutes.
  5. Disconnect the charging hose from the vacuum pump and from the service ports of the suction and liquid valves.
  6. Tighten the service port caps from both valves.
  7. Remove the valve caps from both valves, and open them using a hexagonal Allen wrench.
  8. Remount valve caps onto both of the valves.
  9. Check for gas leaks from the four unions and from the valve caps. Test with electronic leak detector or with a sponge immersed in soapy water for bubbles.

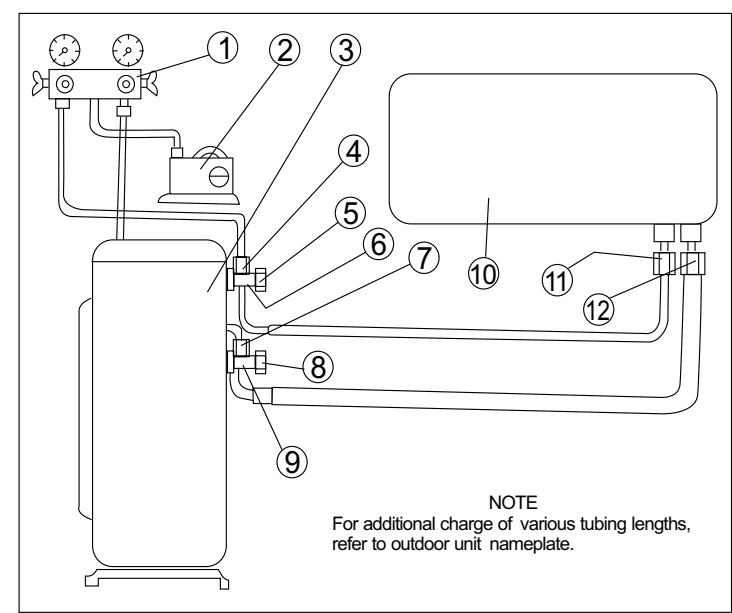

**5 CONNECT THE CABLE TO THE INDOOR AND OUTDOOR UNIT**

**ELECTRICAL REQUIREMENTS**

Electrical wiring and connections should be made by qualified electricians and in accordance with local electrical codes and regulation. The air conditioner units must be grounded. The air conditioner unit must be connected to an adequate power outlet from a separate branch circuit protected by a time delay circuit breaker, as specified on unit's nameplate. Voltage should not vary beyond ±10% of the rated voltage.

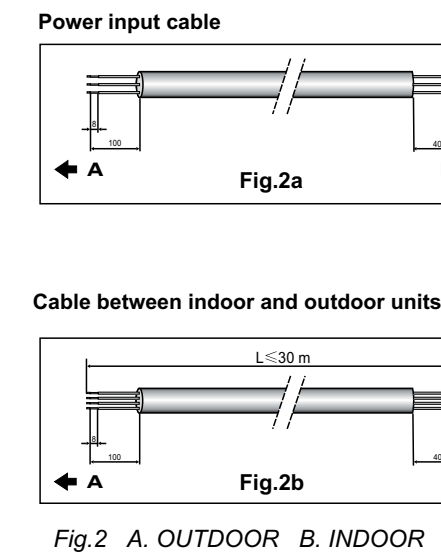

1. To connect the indoor unit to the outdoor unit use the following electrical cables.
  - Electrical connections:
  - Power input cable: 3 wires × 1.5 mm²
  - Cable between indoor and outdoor units: 4 wires × 1.5 mm²
2. Prepare the cable ends for the power input and for the cables between outdoor and indoor units as shown in figure 2a and 2b respectively.
3. Connect the cable ends to the terminals of the indoor and outdoor units, as shown in fig 3.
4. Secure the multiple wire power cable with the cable clamps.

Fig. 1 Terminal 2. Cover 3. Cable clamp

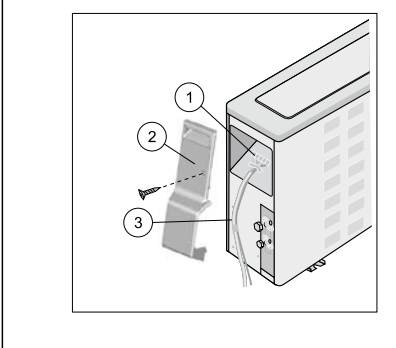

- NOTES:**
1. The wire color code can be selected by the installer.

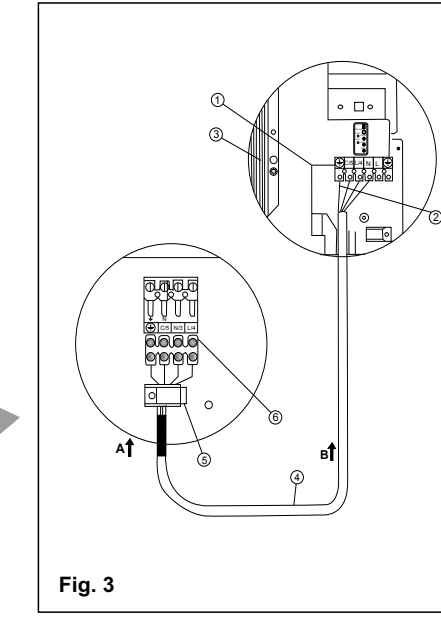

**6 PIPE INSULATION**

1. Please carry out insulation at pipe connection portion as mentioned in Indoor/Outdoor Unit Installing Diagram. Please wrap the insulated piping end to prevent water from getting inside the piping.
2. If drain hose or connecting piping is in the room (where dew may form), please increase the insulation by using POLY-E FOAM with thickness 6 mm or above.

**HOW TO TAKE OUT FRONT GRILLE**

Please follow the steps below to take out front grille if necessary such as when servicing.

1. Set the vertical airflow direction louver to the horizontal position.
2. Slide down the three caps on the front grille as shown in the illustration at right, and then remove the three mounting screws.
3. Pull the lower section of the front grille towards you to remove the front grille.

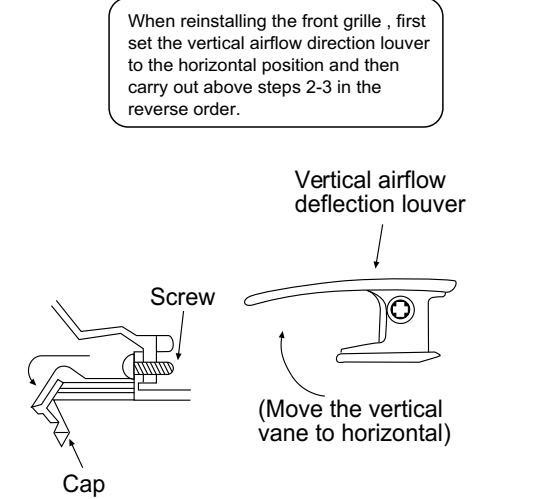

**DISPOSAL OF OUTDOOR UNIT DRAIN WATER**

If a drain elbow is used, the unit should be placed on a stand which is taller than 3 cm.

**CHECK THE DRAINAGE**

- Open front panel and remove air filters. (Drainage checking can be carried out without removing the front grille.)
- Pour a glass of water into the drain tray-styrofoam. Ensure that water flows out from drain hose of the indoor unit.

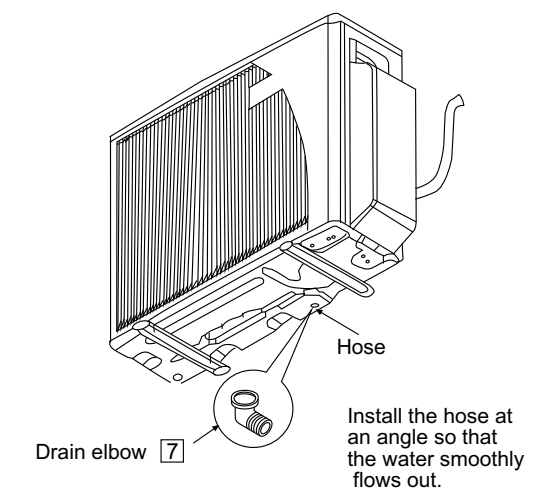

**CHECK ITEMS**

- Is there any gas leakage at flare nut connections?
- Has the heat insulation been carried out at flare nut connection?
- Is the connecting cable being fixed to terminal board firmly?
- Is the connecting cable being clamped firmly?
- Is the drainage ok? (Refer to "Check the drainage" section)
- Is the earth wire connection properly done?
- Is the indoor unit properly hooked to the installation plate?
- Is the power supply voltage complied with rated value?
- Is there any abnormal sound?
- Is the cooling operation normal?
- Is the thermostat operation normal?
- Is the remote control's LCD operation normal?

**EVALUATION OF THE PERFORMANCE**

- Operate the unit at cooling operation mode for fifteen minutes or more.
- Measure the temperature of the intake and discharge air. Ensure the difference between the intake temperature and the discharge is more than 8°C.

