



# Service Manual

## Delta DCI Series

---

Indoor Units	Outdoor Units
Delta 25	DCR 25 Z
Delta 35	DCR 35 Z



---

**REFRIGERANT**

**R410A**

**HEAT PUMP**

**SM DELTAZ 1-E.0 GB**

**NOVEMBER – 2008**

**LIST OF EFFECTIVE PAGES**

**Note:** Changes in the pages are indicated by a “Revision#” in the footer of each effected page (when none indicates no changes in the relevant page). All pages in the following list represent effected/ non effected pages divided by chapters.

Dates of issue for original and changed pages are:

Original ..... 0 ..... 20 November 2008

Total number of pages in this publication is 70 consisting of the following:

Page No.	Revision No. #		Page No.	Revision No. #		Page No.	Revision No. #
----------	----------------	--	----------	----------------	--	----------	----------------

Title ..... 0  
 A ..... 0  
 i ..... 0  
 1-1 - 1-3 ..... 0  
 2-1 - 2-4 ..... 0  
 3-1 ..... 0  
 4-1 - 4-3 ..... 0  
 5-1 - 5-20 ..... 0  
 6-1 - 6-4 ..... 0  
 7-1 ..... 0  
 8-1 ..... 0  
 9-1 ..... 0  
 10-1 ..... 0  
 11-1-11-14 ..... 0  
 12-1-12-7 ..... 0  
 13-1-13-11 ..... 0  
 Appendix -A ..... 0

- Zero in this column indicates an original page.

## Table of Contents

1.	INTRODUCTION .....	1-1
2.	PRODUCT DATA SHEET .....	2-1
3.	RATING CONDITIONS .....	3-1
4.	OUTLINE DIMENSIONS .....	4-1
5.	PERFORMANCE DATA & PRESSURE CURVES .....	5-1
6.	SOUND LEVEL CHARACTERISTICS .....	6-1
7.	ELECTRICAL DATA.....	7-1
8.	WIRING DIAGRAMS .....	8-1
9.	REFRIGERATION DIAGRAMS .....	9-1
10.	TUBING CONNECTIONS.....	10-1
11.	CONTROL SYSTEM .....	11-1
12.	TROUBLESHOOTING .....	12-1
13.	EXPLODED VIEWS AND SPARE PARTS LISTS.....	13-1
14.	APPENDIX A .....	14-1

# 1. INTRODUCTION

## 1.1 General

The new **Delta DC Inverter** split wall mounted series comprise RC (heat pump) models, as follows:

- **Delta 25**
- **Delta 35**

The indoor **Delta** units are available as LED display types only, featuring esthetic design, compact dimensions, and low noise operation.

## 1.2 Main Features

The **Delta** series benefits from the most advanced innovations, namely:

- DC Inverter Technology
- R410A
- Microprocessor control.
- Infrared remote control with liquid crystal display.
- Indoor large diameter cross flow fan, allowing low noise level operation.
- Bended indoor coil with treated aluminum fins and coating for improved efficiency.
- High COP.
- Pre-Charged units up to the max allowing tubing distance.
- Heating operation at outdoor temperature down to -15°C
- Advanced test and diagnostics mode.
- M2L diagnostics software cable port (for PC)
- Easy access to the interconnecting tubing and wiring connections, so that removing the front grill or casing is not necessary.
- Refrigerant pipes can be connected to the indoor unit from 5 different optional directions.
- Automatic treated air sweep.
- Easy installation and service.

### 1.3 Indoor Unit

The indoor unit is wall mounted, and can be easily fitted to many types of residential and commercial applications.

It includes:

- Casing with air inlet and outlet grills.
- A large-diameter tangential fan.
- Bended coil with treated aluminum fins.
- Motorized flaps.
- Variable Speed motor (PG).
- Advanced electronic control box assembly.
- Interconnecting wiring terminal block.
- Mounting plate.

### 1.4 Filtration

The **Delta** series presents several types of air filters:

- Easily accessible, and re-usable pre-filters (mesh).
- Pre-charged electrostatic filter (optional).
- **Active carbon filter (optional).**

### 1.5 Control

The microprocessor indoor controller, and an infrared remote control, supplied as standard, provide complete operating function and programming. For further details please refer to the Operation Manual, Appendix A.

### 1.6 Outdoor Unit

The **Delta** outdoor units can be installed as floor or wall mounted units by using a wall supporting bracket. The metal sheets are protected by anti-corrosion paint work allowing long life resistance. All outdoor units are pre-charged. For further information please refer to the Product Data Sheet, Chapter 2.

It includes :

- Compressor mounted in a soundproofed component.

**Single DC Rotary** — For DCR 25Z, DCR 35Z.

- Axial fan.
- Outdoor coil with hydrophilic louver fins.
- Outlet air fan grill.
- Display (3 LED's).
- 2 speed AC motor.

### 1.7 Tubing Connections

Flare type interconnecting tubing to be produced on site.  
For further details please refer to the Installation Manual, Outdoor Chapter 9.

### 1.8 Inbox Documentation

Each unit is supplied with its own installation and operation manuals, one simly remote control manual.

### 1.9 Matching Table

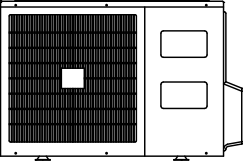
OUTDOOR UNITS			INDOOR UNITS	
	MODEL	REFR''	Delta 25	Delta 35
	DCR 25Z	R410A	√	
	DCR 35Z	R410A		√

## 2. PRODUCT DATA SHEET

### 2.1 Delta 25 / DCR 25Z R410A

Model Indoor Unit				<b>DELTA 25 DCI</b>	
Model Outdoor Unit				<b>DCR 25 Z R410A</b>	
Installation Method of Pipe				Flared	
Characteristics		Units		Cooling	Heating
Capacity <sup>(4)</sup>			Btu/hr	8530(4090-10240)	8530(3410-10910)
			kW	2.5(1.2-3.0)	2.5(1.0-3.2)
Power input <sup>(4)</sup>			kW	0.78	0.69
EER (Cooling) or COP(Heating) <sup>(4)</sup>			W/W	3.21	3.61
Energy efficiency class				A	A
Power supply			V/Ph/Hz	220-240V ~1Ph 50/60Hz	
Rated current			A	3.5	3.1
Starting current			A	10.5	
Circuit breaker rating			A	10	
INDOOR	Fan type & quantity			Crossflow x 1	
	Fan speeds	H/M/L	RPM	1200/1050/850	
	Air flow <sup>(1)</sup>	H/M/L	m <sup>3</sup> /hr	420/350/270	
	External static pressure	Min-Max	Pa	0	
	Sound power level <sup>(2)</sup>	H/M/L	dB(A)	54/50/47	
	Sound pressure level <sup>(3)</sup>	H/M/L	dB(A)	39/35/32	
	Moisture removal		l/hr	1	
	Condensate drain tube I.D		mm	16	
	Dimensions	WxHxD	mm	680x185x250	
	Weight		kg	7	
	Package dimensions	WxHxD	mm	740x265x320	
	Packaged weight		kg	10	
	Units per pallet		units	36 units per pallet	
	Stacking height		units	9 levels	
OUTDOOR	Refrigerant control			Capillary	
	Compressor type,model			Rotary, TOSHIBA DA89X1C-20FZ3	
	Fan type & quantity			Propeller(direct) x 1	
	Fan speeds	H/L	RPM	830	
	Air flow	H/L	m <sup>3</sup> /hr	1460	
	Sound power level	H/L	dB(A)	65	
	Sound pressure level <sup>(3)</sup>	H/L	dB(A)	55	
	Dimensions	WxHxD	mm	760x245x545	
	Weight		kg	31	
	Package dimensions	WxHxD	mm	880x310x610	
	Packaged weight		kg	33	
	Units per pallet		Units	12 units per pallet	
	Stacking height		units	3 levels	
	Refrigerant type			R410A	
	Refrigerant chargeless distance		kg/m	0.85kg/7.5m	
	Additional charge per 1 meter		g/m	L≤10m:+0g 10<L≤15m:+200g	
	Connections between units	Liquid line	In.(mm)	1/4"(6.35)	
Suction line		In.(mm)	3/8"(9.53)		
Max.tubing length		m.	Max.15		
Max.height difference		m.	Max. 10		
Operation control type			Remote control		
Heating elements			kW		
Others					

<sup>(1)</sup>Airflow in ducted units; at nominal external static pressure.

<sup>(2)</sup>Sound power in ducted units is measured at air discharge.

<sup>(3)</sup>Sound pressure level measured at 1-meter distance from unit.

<sup>(4)</sup>Rating conditions in accordance to ISO 5151 and ISO 13253 (for ducted units).

## 2.2 Delta 35 / DCR 35 Z R410A

Model Indoor Unit			DELTA 35 DCI		
Model Outdoor Unit			DCR 35 Z R410A		
Installation Method of Pipe			Flared		
Characteristics			Units	Cooling	Heating
Capacity <sup>(4)</sup>			Btu/hr	11940(4100-13640)	11940(4100-13330)
			kW	3.5(1.2-4.0)	3.5(1.2-3.9)
Power input <sup>(4)</sup>			kW	1.09	0.97
EER (Cooling) or COP(Heating) <sup>(4)</sup>			W/W	3.21	3.61
Energy efficiency class				A	A
Power supply			V/Ph/Hz	220-240V ~1Ph 50/60Hz	
Rated current			A	4.9	4.3
Starting current			A	10.5	
Circuit breaker rating			A	15	
INDOOR	Fan type & quantity			Crossflow x 1	
	Fan speeds	H/M/L	RPM	1200/1000/850	
	Air flow <sup>(1)</sup>	H/M/L	m3/hr	550/450/350	
	External static pressure	Min-Max	Pa	0	
	Sound power level <sup>(2)</sup>	H/M/L	dB(A)	56/50/46	
	Sound pressure level <sup>(3)</sup>	H/M/L	dB(A)	39/33/29	
	Moisture removal		l/hr	1.5	
	Condensate drain tube I.D		mm	16	
	Dimensions	WxHxD	mm	840x185x250	
	Weight		kg	8	
	Package dimensions	WxHxD	mm	930x265x320	
	Packaged weight		kg	11	
	Units per pallet		units	36 units per pallet	
	Stacking height		units	9 levels	
	OUTDOOR	Refrigerant control			Capillary
Compressor type,model			Rotary, TOSHIBA DA108X1C-20FZ3		
Fan type & quantity			Propeller(direct) x 1		
Fan speeds		H/L	RPM	830	
Air flow		H/L	m3/hr	1460	
Sound power level		H/L	dB(A)	66	
Sound pressure level <sup>(3)</sup>		H/L	dB(A)	56	
Dimensions		WxHxD	mm	760x245x545	
Weight			kg	32	
Package dimensions		WxHxD	mm	880x310x610	
Packaged weight			kg	34	
Units per pallet			Units	12 units per pallet	
Stacking height			units	3 levels	
Refrigerant type				R410A	
Refrigerant chargeless distance			kg/m	1.0kg/7.5m	
Additional charge per 1 meter			g/m	L≤10m:+0g 10L≤20m :+200g	
Connections between units		Liquid line	In.(mm)	1/4"(6.35)	
		Suction line	In.(mm)	3/8"(9.53)	
	Max.tubing length	m.	Max.15		
	Max.height difference	m.	Max. 10		
Operation control type			Remote control		
Heating elements			kW		
Others			No		

<sup>(1)</sup> Airflow in ducted units; at nominal external static pressure.  
<sup>(2)</sup> Sound power in ducted units is measured at air discharge.  
<sup>(3)</sup> Sound pressure level measured at 1-meter distance from unit.  
<sup>(4)</sup> Rating conditions in accordance to ISO 5151 and ISO 13253 (for ducted units).



### 3. RATING CONDITIONS

Rating conditions in accordance with ISO 5151 and ISO 13253 (for ducted units).

**Cooling:**

Indoor: 27°C DB 19°C WB

Outdoor: 35°C DB

**Heating:**

Indoor: 20°C DB

Outdoor: 7°C DB 6°C WB

#### 3.1 Operating Limits

##### 3.1.1 R410A

		Indoor	Outdoor
Cooling	Upper limit	32°C DB 23°C WB	46°C DB
	Lower limit	21°C DB 15°C WB	0°C DB
Heating	Upper limit	27°C DB	24°C DB 18°C WB
	Lower limit	10°C DB	-15°C DB -16°C WB
Voltage		198 – 264 V	

## 4. OUTLINE DIMENSIONS

### 4.1 Indoor Unit: Delta 25 DCI

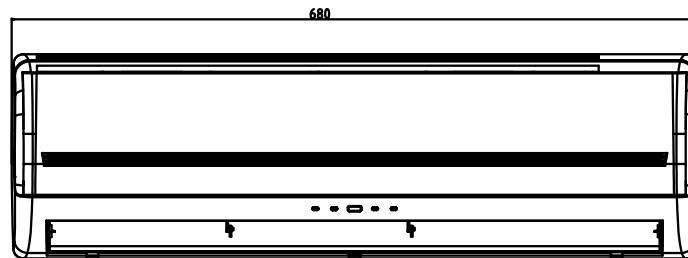
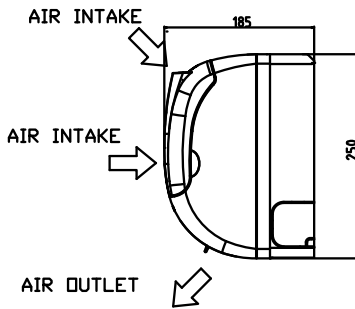
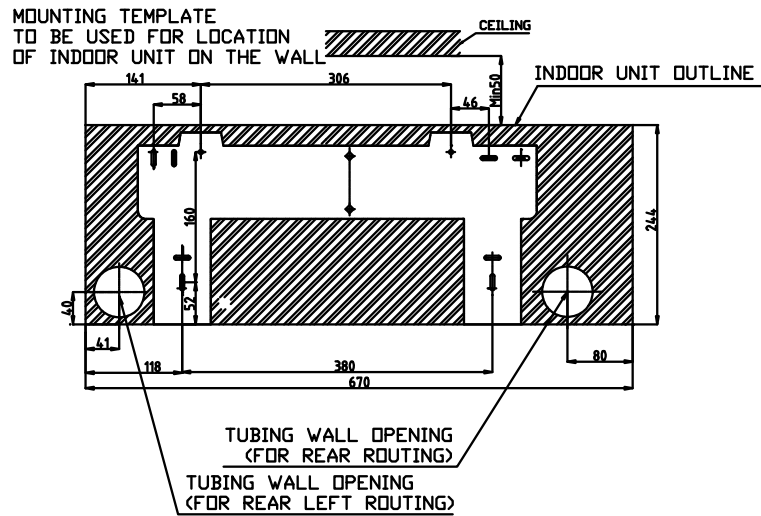

### 4.2 Indoor Unit: Delta 35 DCI

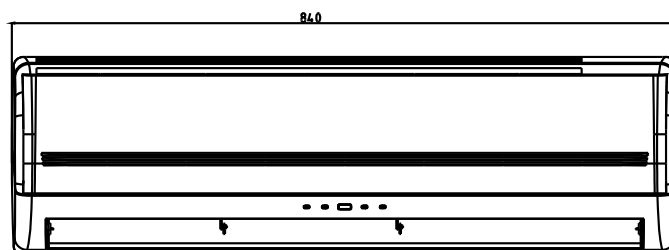
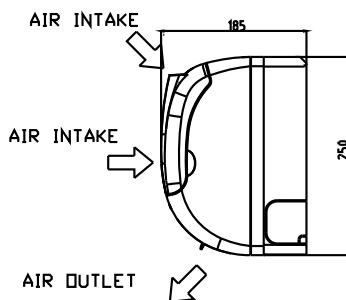
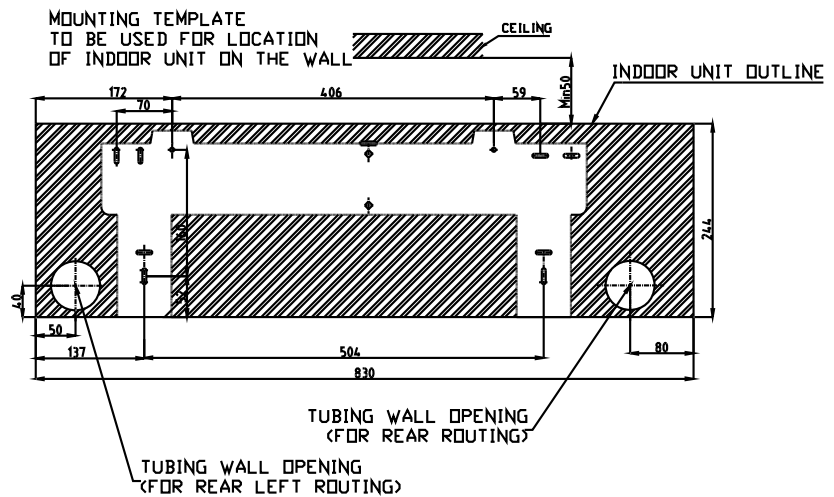

**4.3 Outdoor Unit: DCR 25 Z, DCR 35 Z DCI**

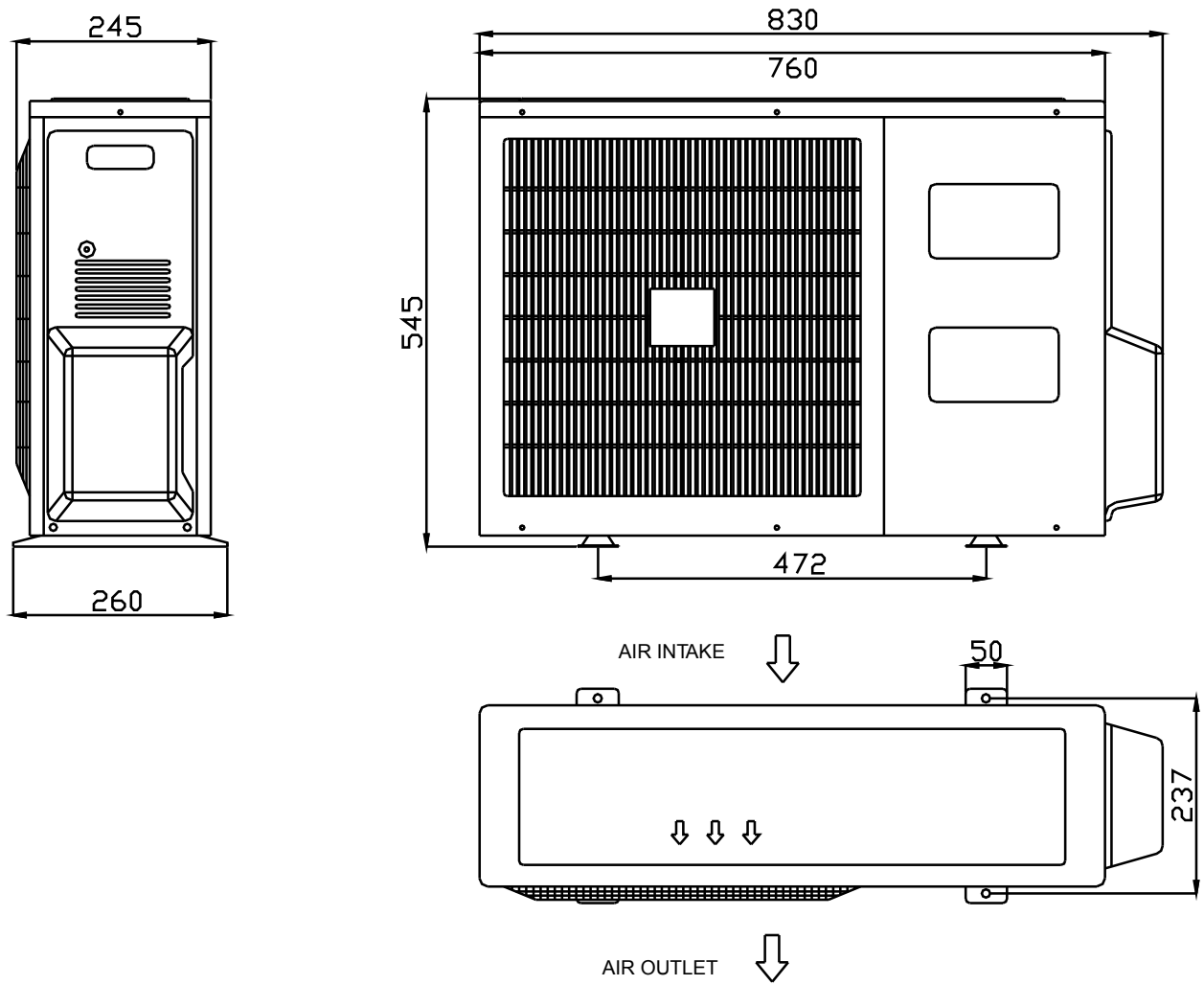

## 5. PERFORMANCE DATA

### 5.1 Delta 25 / DCR 25 Z R410A

#### 5.1.1 Cooling Capacity (kW) – Run Mode

230[V] : Indoor Fan at High Speed.

OD COIL ENTERING AIR DB TEMPERATURE [°C]		ID COIL ENTERING AIR DB/WB TEMPERATURE [°C]				
		22/15	24/17	27/19	29/21	32/23
0 - 20 (protection range)	TC	80 - 110 % of nominal				
	SC	80 - 105 % of nominal				
	PI	25 - 50 % of nominal				
25	TC	2.41	2.57	2.73	2.89	3.05
	SC	1.67	1.71	1.74	1.77	1.81
	PI	0.59	0.60	0.61	0.62	0.63
30	TC	2.30	2.46	2.62	2.77	2.93
	SC	1.63	1.67	1.70	1.73	1.77
	PI	0.66	0.67	0.68	0.69	0.70
35	TC	2.18	2.34	<b>2.50</b>	2.66	2.82
	SC	1.59	1.63	<b>1.77</b>	1.69	1.73
	PI	0.73	0.74	<b>0.78</b>	0.76	0.77
40	TC	2.07	2.23	2.39	2.54	2.70
	SC	1.55	1.59	1.62	1.65	1.69
	PI	0.80	0.81	0.82	0.83	0.84
46	TC	1.93	2.09	2.25	2.41	2.56
	SC	1.50	1.54	1.57	1.61	1.64
	PI	0.88	0.89	0.90	0.91	0.92

#### LEGEND

- TC – Total Cooling Capacity, kW
- SC – Sensible Capacity, kW
- PI – Power Input, kW
- WB – Wet Bulb Temp., (°C)
- DB – Dry Bulb Temp., (°C)
- ID – Indoor
- OD – Outdoor

#### 5.1.2 Capacity Correction Factors

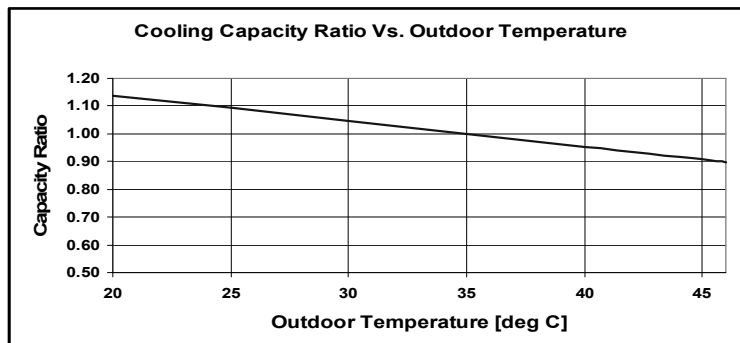

**5.1.3 Heating Capacity (kW) - Run Mode**  
**230[V] : Indoor Fan at High Speed.**

OD COIL ENTERING AIR DB/WB TEMPERATURE [°C]		ID COIL ENTERING AIR DB TEMPERATURE [°C]		
		15	20	25
-15/-16	TC	1.78	1.66	1.53
	PI	0.49	0.54	0.59
-10/-12	TC	1.98	1.86	1.73
	PI	0.59	0.64	0.69
-7/-8	TC	2.14	2.01	1.89
	PI	0.67	0.72	0.77
-1/-2	TC	2.21	2.09	1.96
	PI	0.71	0.76	0.81
2/1	TC	2.26	2.14	2.01
	PI	0.73	0.78	0.83
7/6	TC	2.92	<b>2.50</b>	2.68
	PI	0.77	<b>0.69</b>	0.87
10/9	TC	3.09	2.96	2.84
	PI	0.82	0.87	0.92
15/12	TC	3.25	3.12	3.00
	PI	0.86	0.91	0.96
15-24 (Protection Range)	TC	85 - 105 % of nominal		
	PI	80 - 120 % of nominal		

**LEGEND**

- TC – Total Heating Capacity, kW
- PI – Power Input, kW
- WB – Wet Bulb Temp., (°C)
- DB – Dry Bulb Temp., (°C)
- ID – Indoor
- OU – Outdoor

**5.1.4 Capacity Correction Factors**

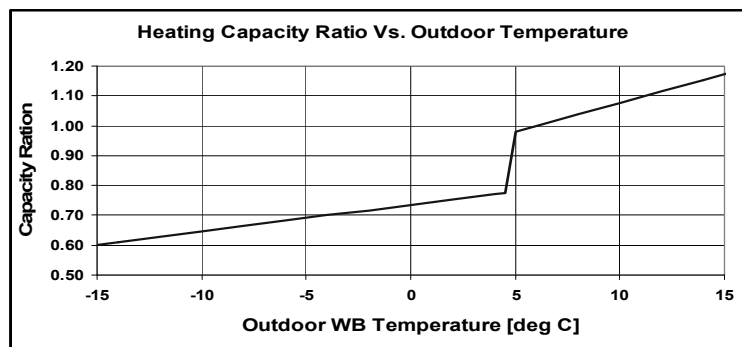

**5.2 Delta 35 / DCR 35 Z R410A**

**5.2.1 Cooling Capacity (kW) – Run Mode**

**230[V] : Indoor Fan at High Speed.**

		ID COIL ENTERING AIR DB/WB TEMPERATURE [°C]				
OD COIL ENTERING AIR DB TEMPERATURE [°C]	DATA	22/15	24/17	27/19	29/21	32/23
<b>-10 - 20</b> (protection range)	<b>TC</b>	80 - 110 % of nominal				
	<b>SC</b>	80 - 105 % of nominal				
	<b>PI</b>	25 - 50 % of nominal				
<b>25</b>	<b>TC</b>	3.38	3.60	3.82	4.04	4.26
	<b>SC</b>	2.54	2.59	2.64	2.69	2.74
	<b>PI</b>	0.81	0.83	0.84	0.86	0.87
<b>30</b>	<b>TC</b>	3.22	3.44	3.66	3.88	4.10
	<b>SC</b>	2.48	2.53	2.58	2.63	2.68
	<b>PI</b>	0.90	0.92	0.94	0.95	0.97
<b>35</b>	<b>TC</b>	3.06	3.28	<b>3.50</b>	3.72	3.94
	<b>SC</b>	2.42	2.47	<b>2.58</b>	2.57	2.62
	<b>PI</b>	1.00	1.01	<b>1.09</b>	1.05	1.06
<b>40</b>	<b>TC</b>	2.90	3.12	3.34	3.56	3.78
	<b>SC</b>	2.36	2.41	2.46	2.51	2.56
	<b>PI</b>	1.09	1.11	1.12	1.14	1.16
<b>46</b>	<b>TC</b>	2.70	2.92	3.15	3.37	3.59
	<b>SC</b>	2.28	2.34	2.39	2.44	2.49
	<b>PI</b>	1.21	1.22	1.24	1.25	1.27

**LEGEND**

- TC – Total Cooling Capacity, kW
- SC – Sensible Capacity, kW
- PI – Power Input, kW
- WB – Wet Bulb Temp., (°C)
- DB – Dry Bulb Temp., (°C)
- ID – Indoor
- OD – Outdoor

**5.2.2 Capacity Correction Factors**

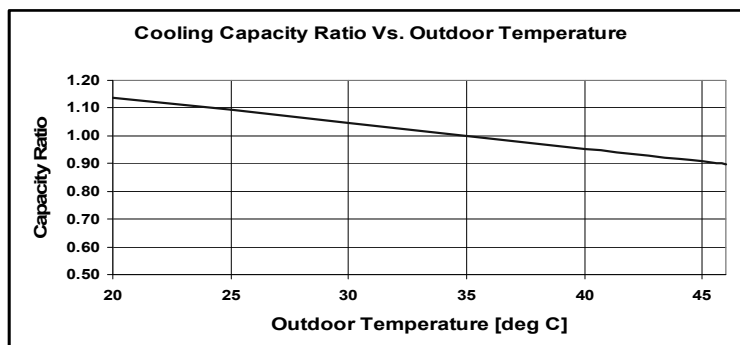

**5.2.3 Heating Capacity (kW) - Run Mode**  
**230[V] : Indoor Fan at High Speed.**

OD COIL ENTERING AIR DB/WB TEMPERATURE [°C]		ID COIL ENTERING AIR DB TEMPERATURE [°C]		
		15	20	25
-15/-16	TC	2.29	2.13	1.97
	PI	0.63	0.69	0.76
-10/-12	TC	2.55	2.39	2.23
	PI	0.76	0.82	0.89
-7/-8	TC	2.75	2.58	2.42
	PI	0.86	0.92	0.98
-1/-2	TC	2.84	2.68	2.52
	PI	0.91	0.97	1.03
2/1	TC	2.91	2.75	2.59
	PI	0.94	1.00	1.07
7/6	TC	3.76	3.50	3.44
	PI	0.99	0.97	1.11
10/9	TC	3.97	3.81	3.65
	PI	1.04	1.11	1.17
15/12	TC	4.17	4.01	3.85
	PI	1.10	1.17	1.23
15-24 (Protection Range)	TC	85 - 105 % of nominal		
	PI	80 - 120 % of nominal		

**LEGEND**

- TC – Total Heating Capacity, kW
- PI – Power Input, kW
- WB – Wet Bulb Temp., (°C)
- DB – Dry Bulb Temp., (°C)
- ID – Indoor
- OU – Outdoor

**5.2.4 Capacity Correction Factors**

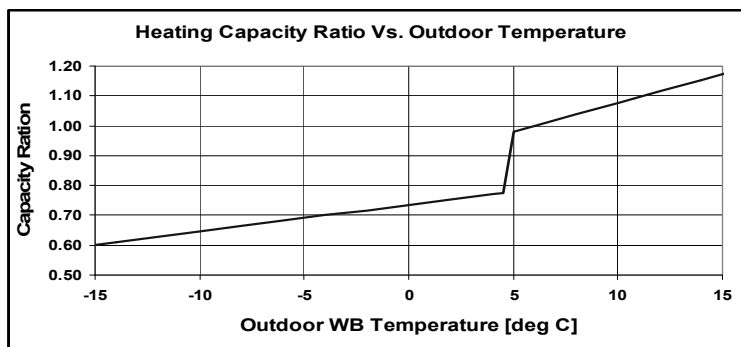

### 5.3 Capacity Correction Factor Due to Tubing Length

#### 5.3.1 Delta 25 DCI : Cooling

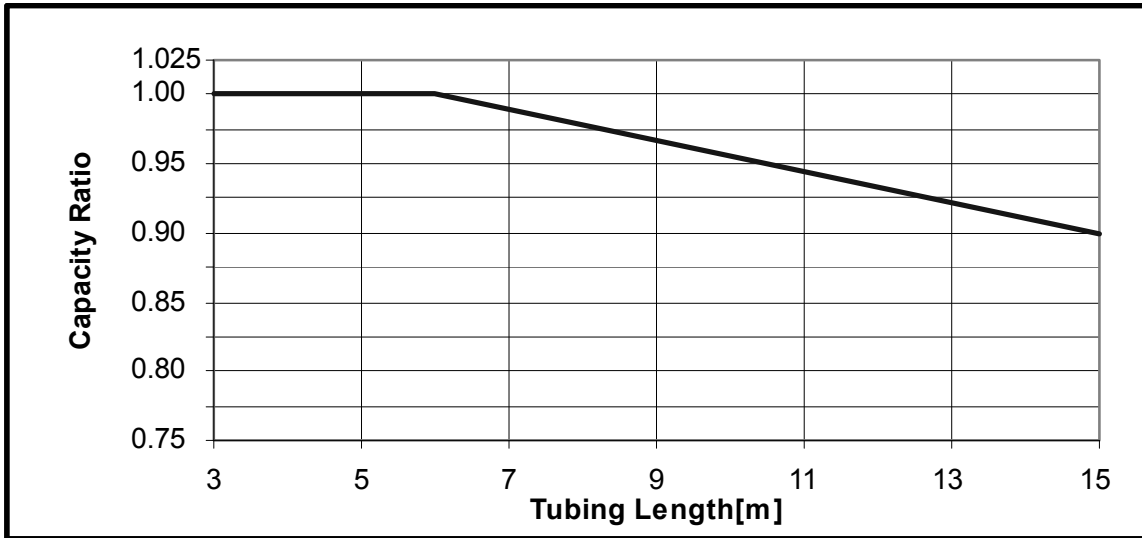

#### 5.3.2 Heating

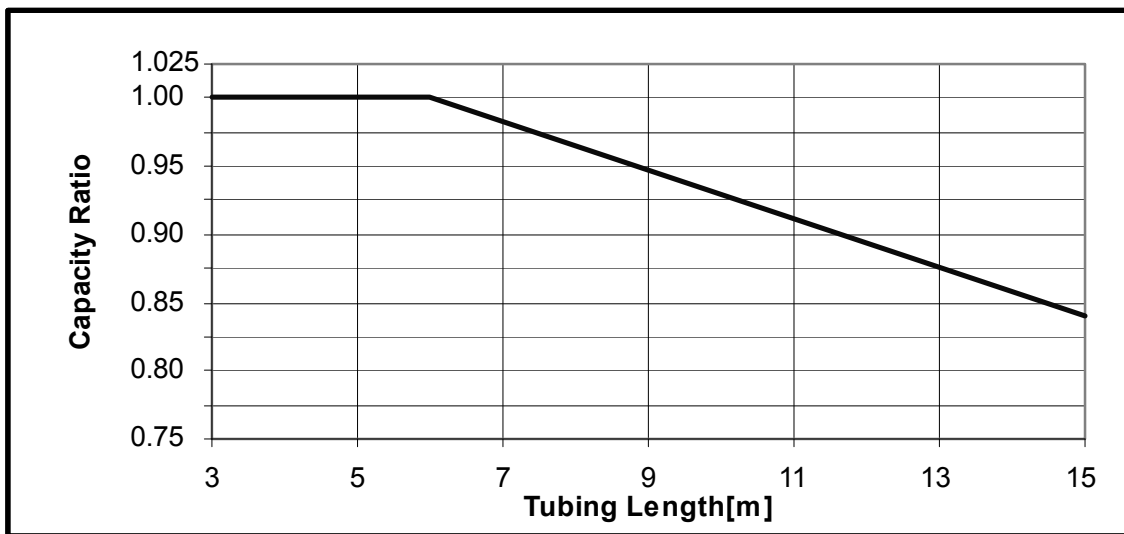



### 5.3.3 Delta 35 DCI : Cooling

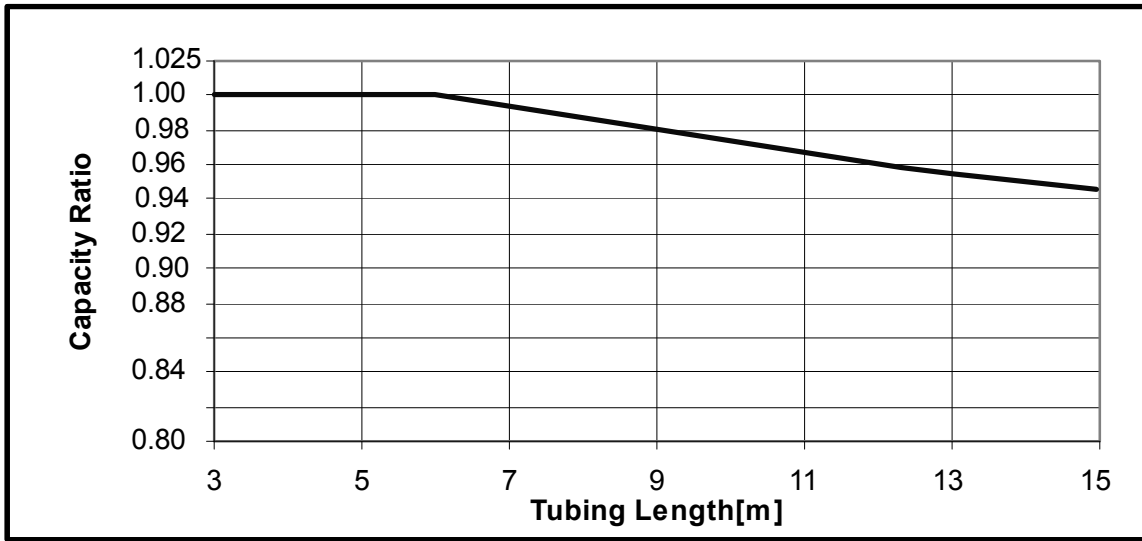

### 5.3.4 Heating

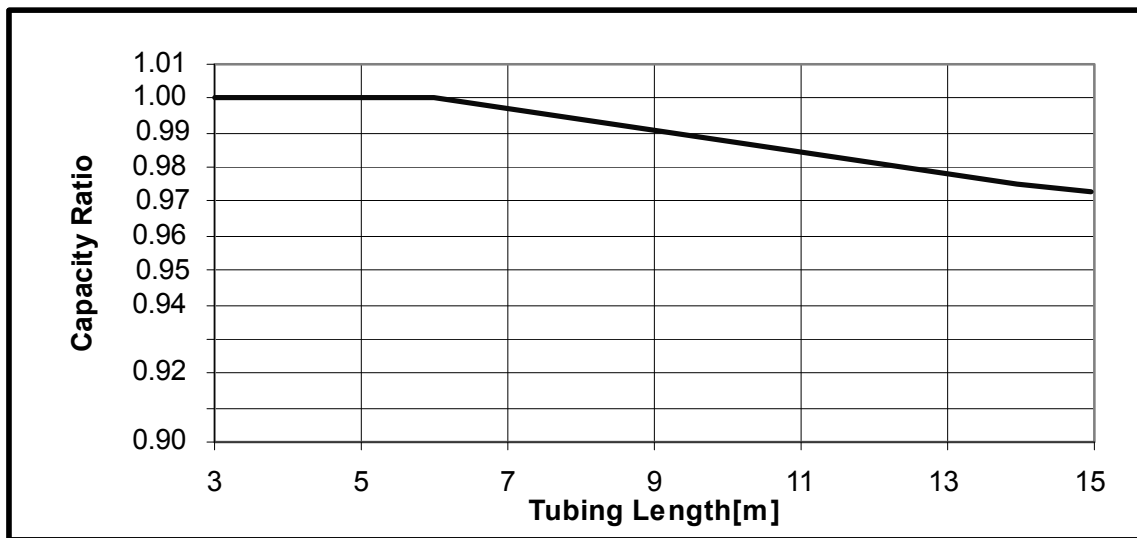

## 5.4 PRESSURE CURVES

### 5.4.1 DELTA 25 / DCR 25 Z R410A

#### 5.4.1.1 Cooling => Test Mode

Suction Pressure VS. Outdoor Temp.

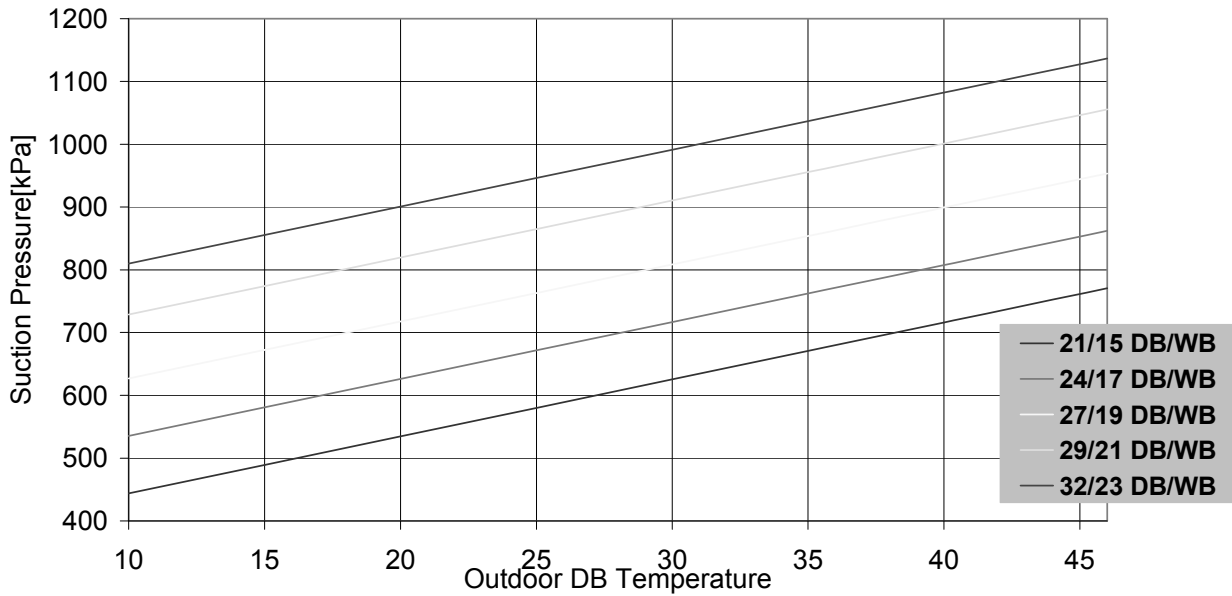

Discharge Pressure VS. Outdoor Temp.

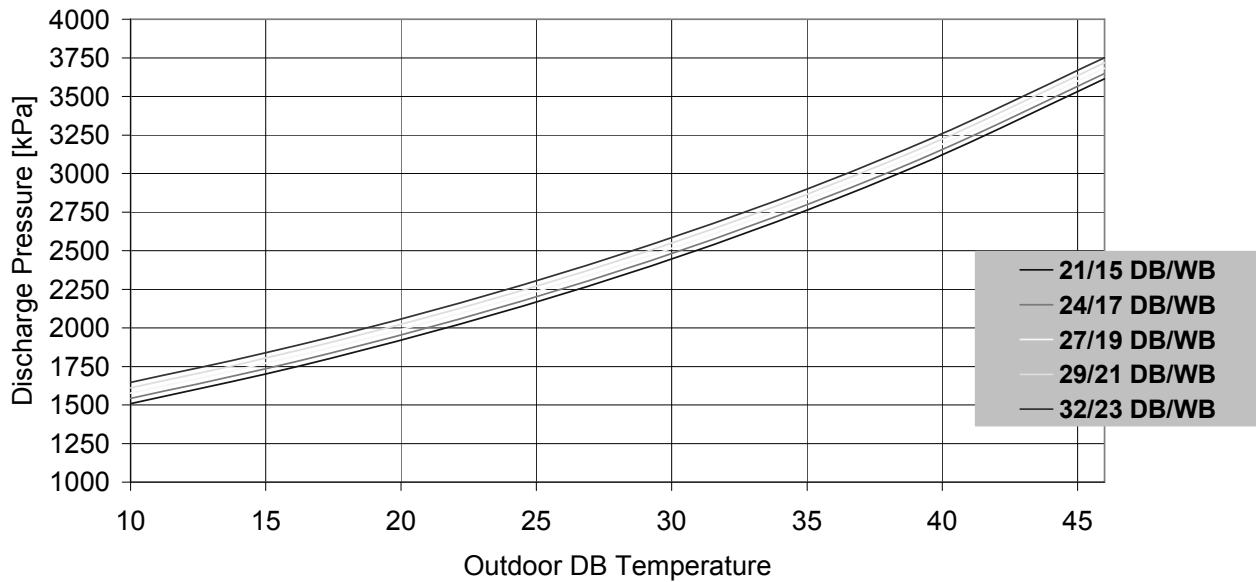

5.4.1.2 Heating => Test Mode

Suction Pressure VS. Outdoor Temp.

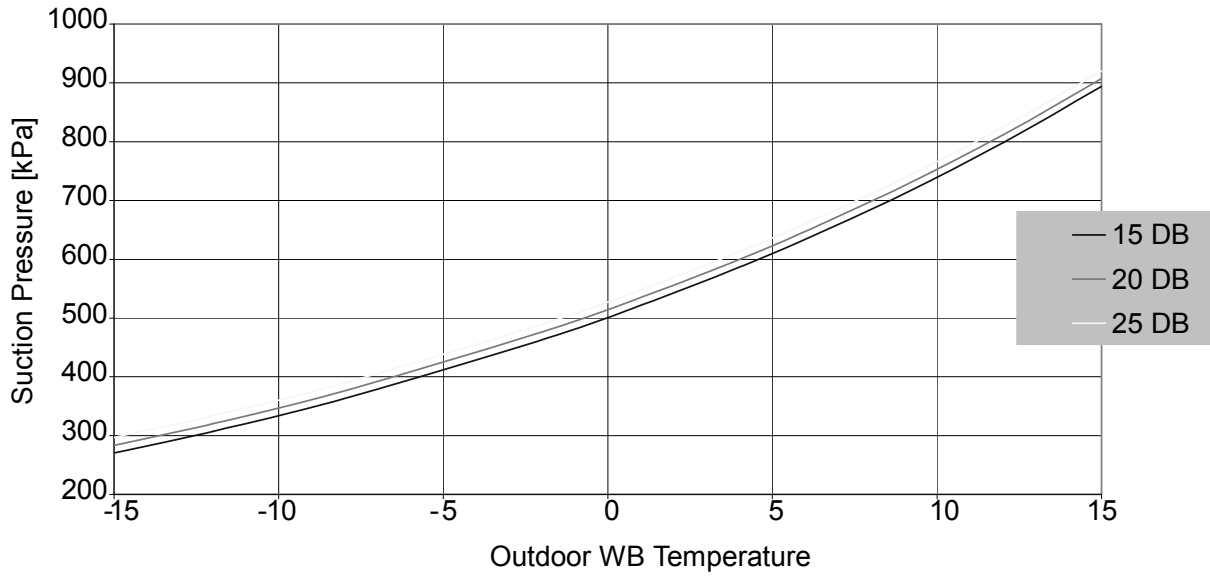

Discharge Pressure VS. Outdoor Temp.

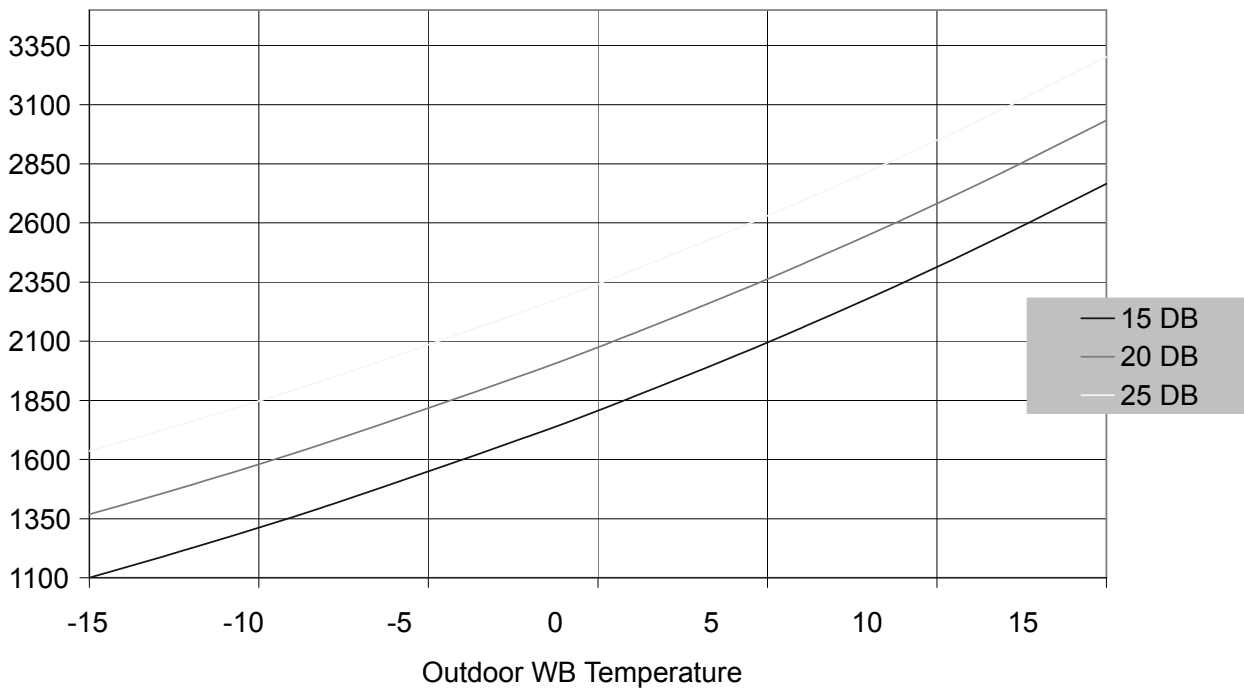

**5.4.2 DELTA 35 / DCR 35 Z R410A**

**5.4.2.1 Cooling => Test Mode**

**Suction Pressure VS. Outdoor Temp.**

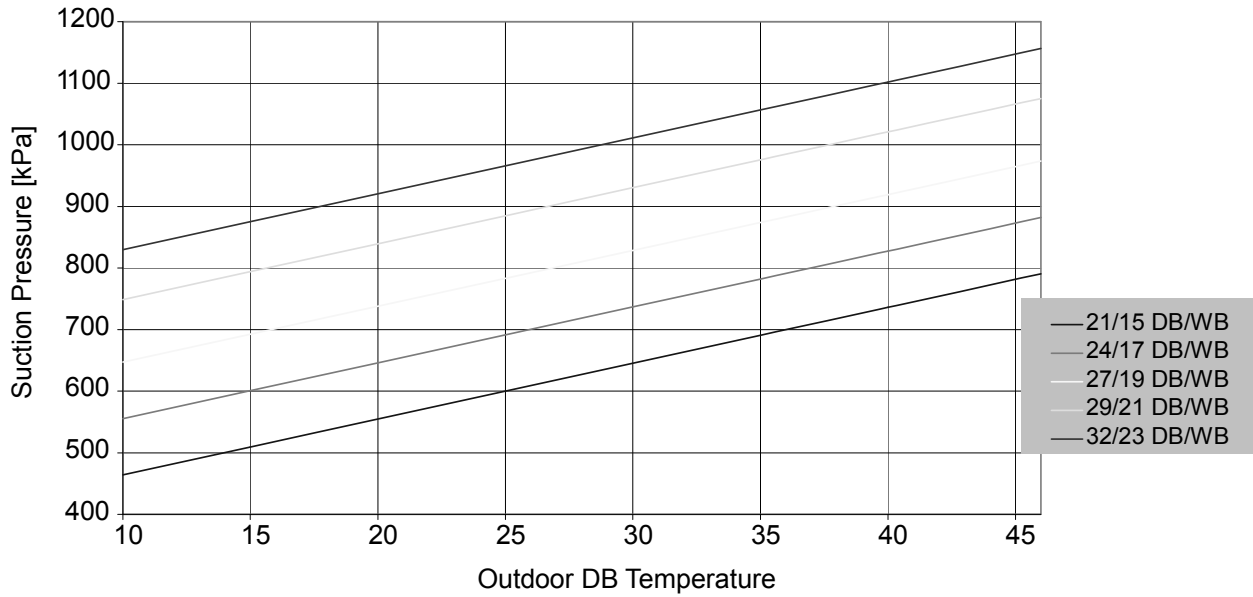

**Discharge Pressure VS. OutdoorTemp.**

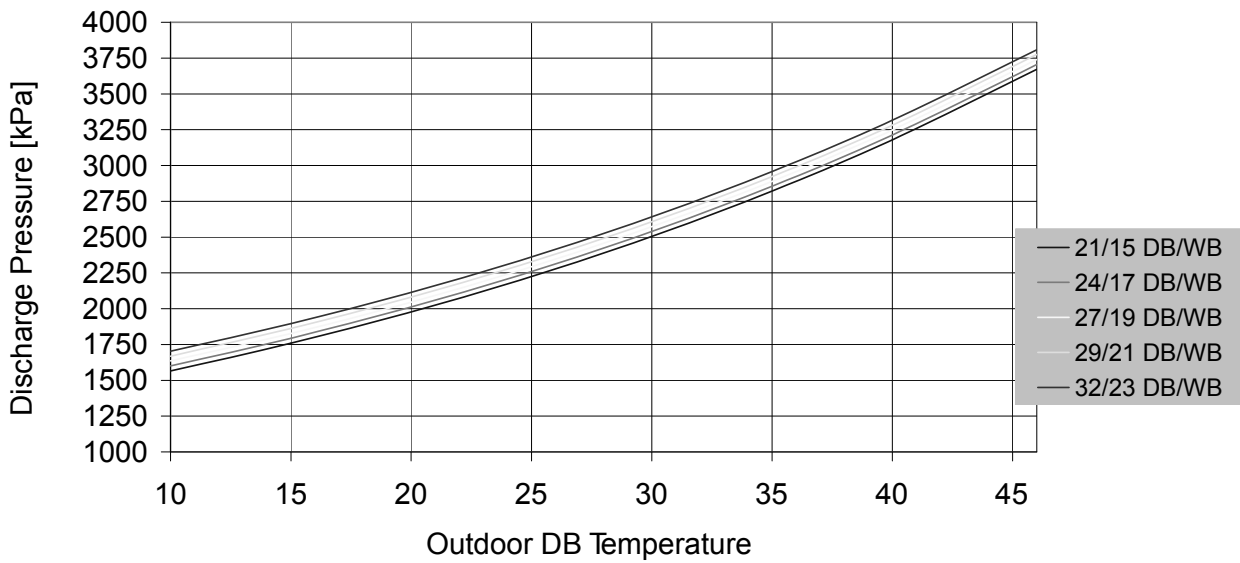

5.4.2.2 Heating =>Test Mode

Suction Pressure VS. Outdoor Temp.

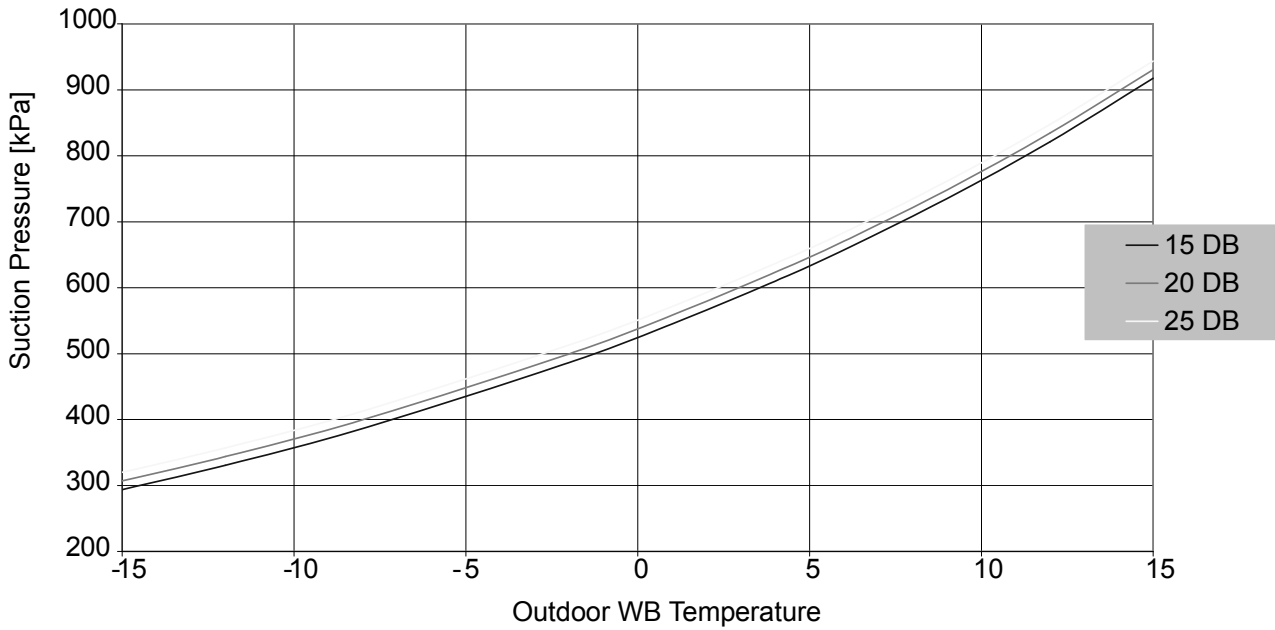

Discharge Pressure VS. Outdoor Temp.

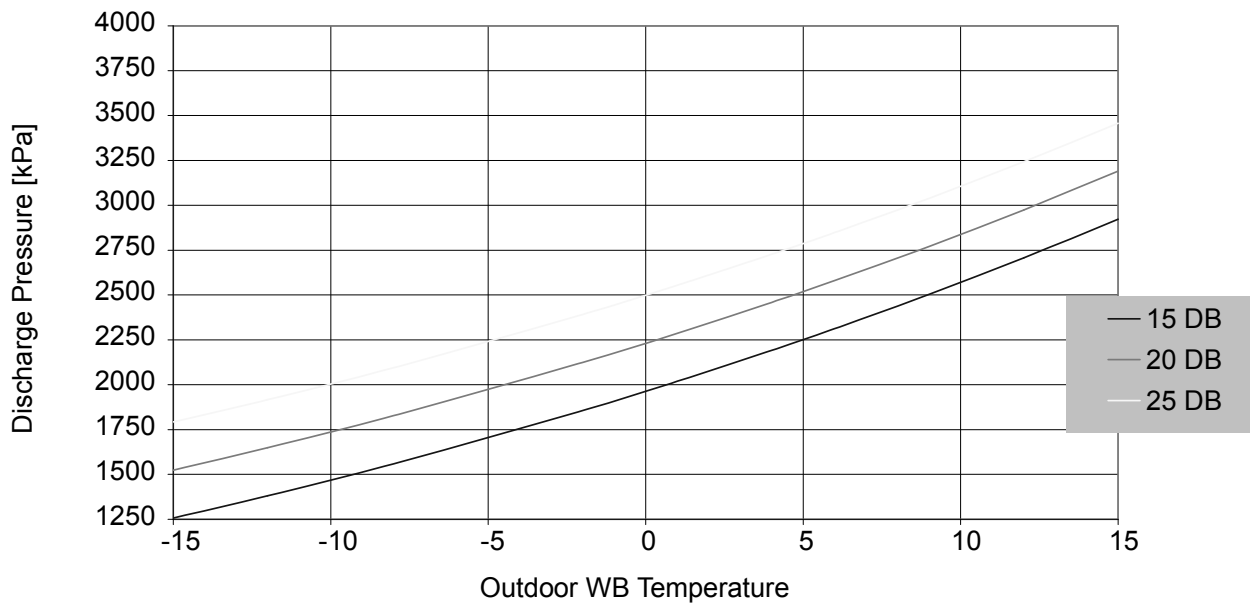

## 6. SOUND LEVEL CHARACTERISTICS

### 6.1 Sound Pressure Level

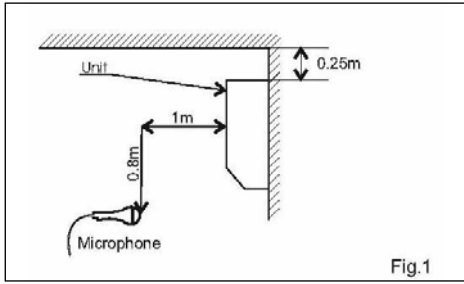

Figure 1. Wall Mounted

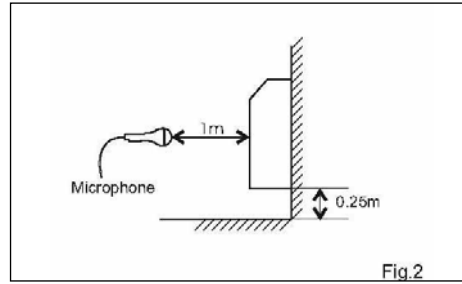

Figure 2. Floor Mounted

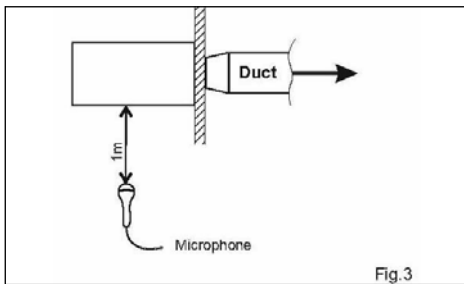

Figure 3. Ducted

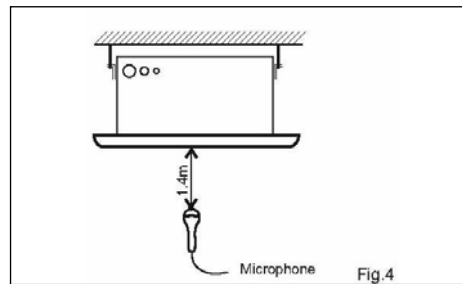
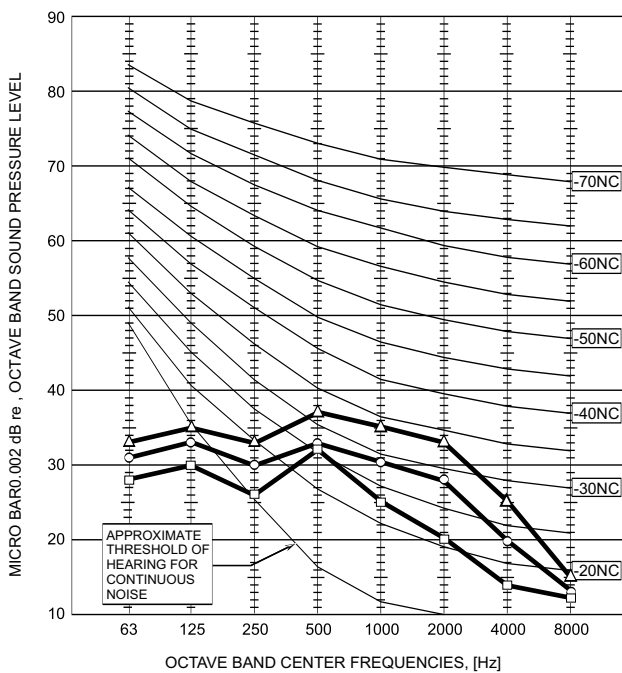

Figure 4. Cassette

### 6.2 Sound Pressure Level Spectrum (Measured as Figure 1)

Delta 25



Delta 35

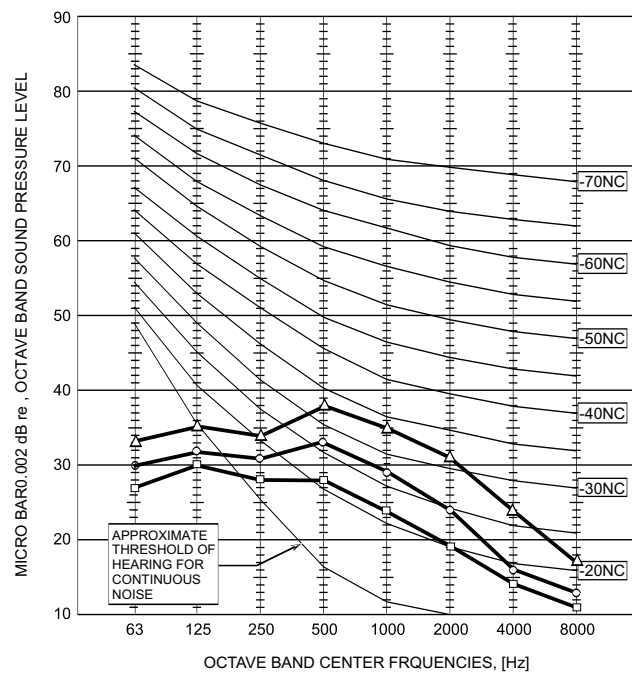

FAN SPEED	LINE
HI	—▲—
ME	—○—
LO	—□—

### 6.3 Outdoor units

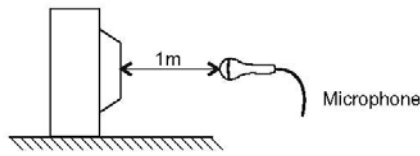
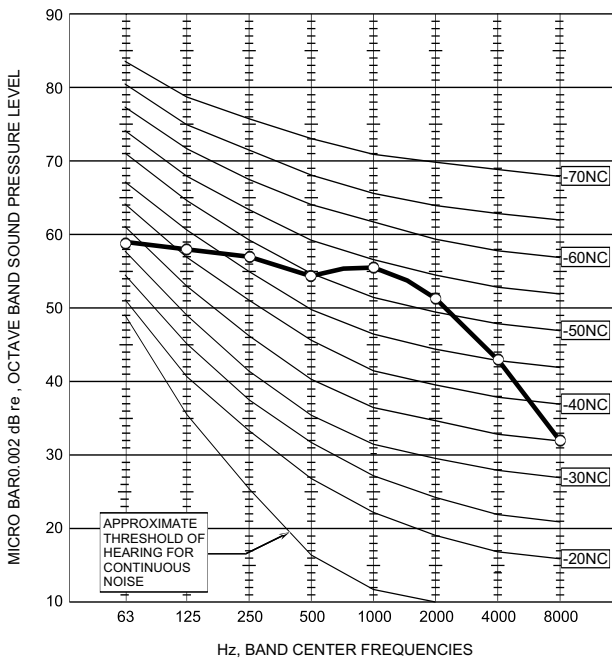

Fig.5

Microphone Distance from Unit

### 6.4 Sound Pressure Level Spectrum (Measured as Figure 5)

DCR 25 Z Cooling



DCR 25 Z Heating

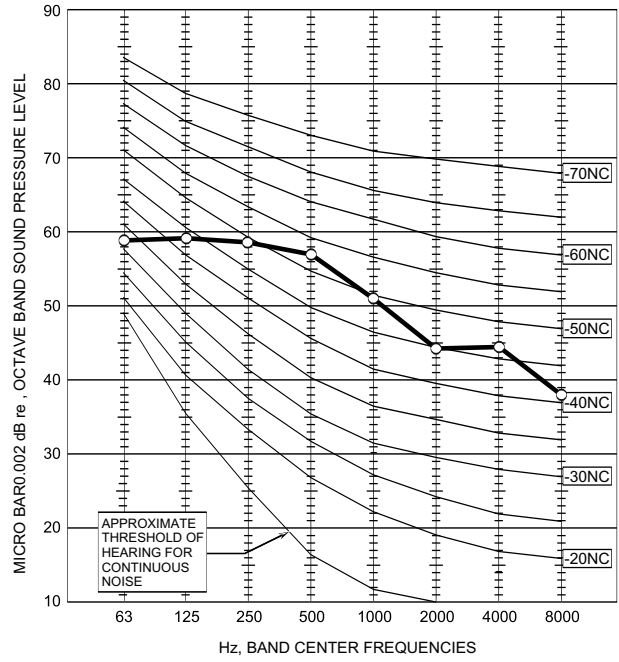

DCR 35 Z Cooling

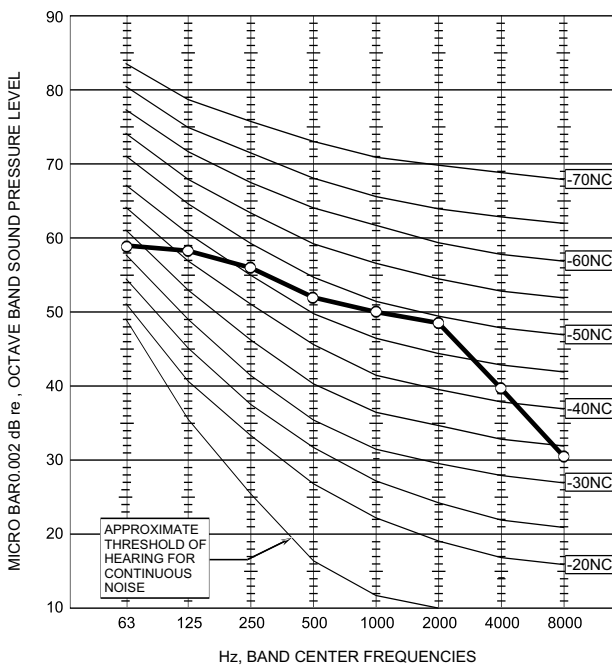

DCR 35 Z Heating

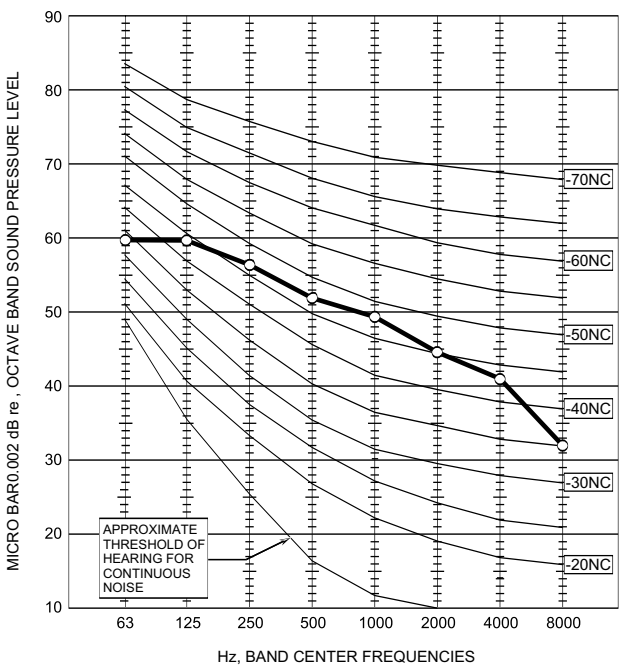

## 7. ELECTRICAL DATA

### 7.1 Single Phase Units

MODEL	Delta 25	Delta 35
Power Supply	To indoor	To indoor
	<b>1PH,220-240V,50Hz</b>	<b>1PH,220-240V,50Hz</b>
Max Current, A	<b>6.3</b>	<b>7.5</b>
Circuit Breaker,A	<b>10</b>	<b>15</b>
Power Supply Wiring No. X Cross Section, mm <sup>2</sup>	<b>3x1.0 mm<sup>2</sup></b>	<b>3x1.5 mm<sup>2</sup></b>
Interconnecting Cable RC Model No. X Cross Section, mm <sup>2</sup>	<b>4x1.0 mm<sup>2</sup></b>	<b>4x1.5 mm<sup>2</sup></b>

**NOTE**

*Power wiring cord should comply with local laws and electrical regulations requirements*



# 8. WIRING DIAGRAMS

## 8.1 Delta 25 / DCR 25 Z, Delta 35 / DCR 35 Z

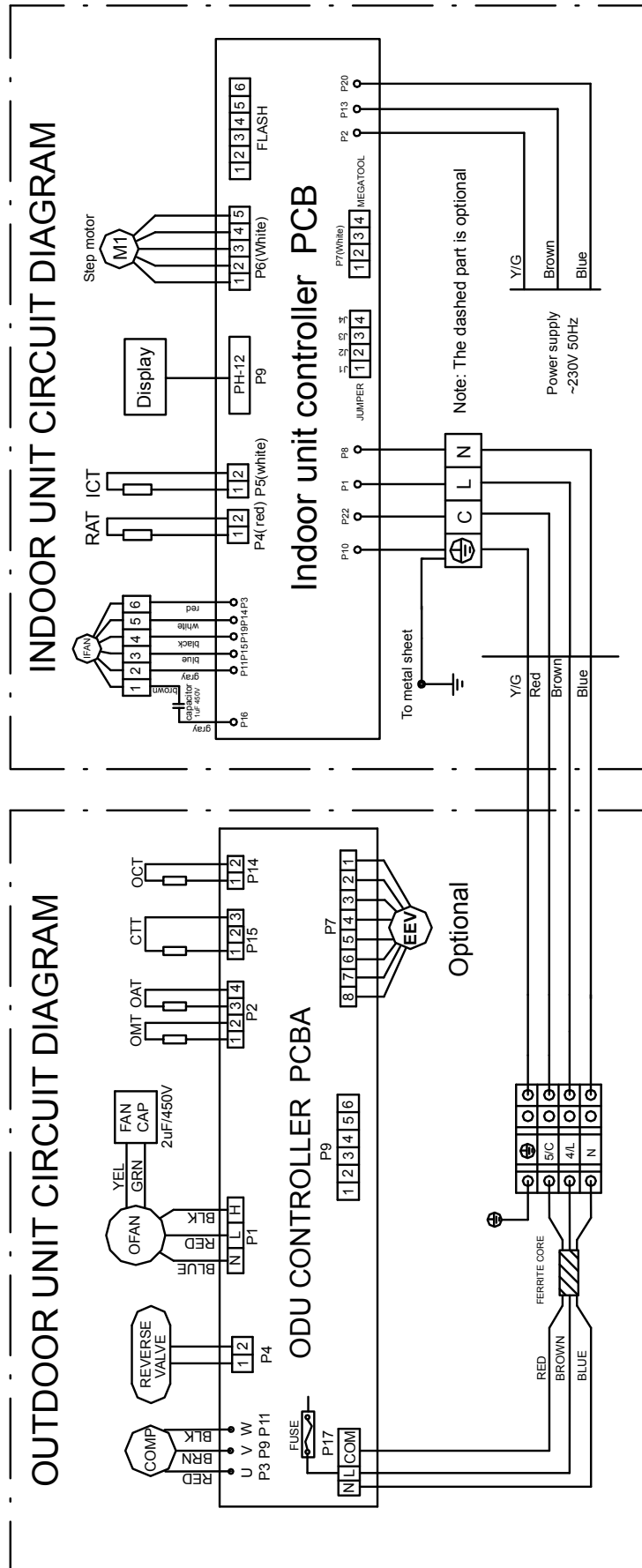

## 9. REFRIGERATION DIAGRAMS

### 9.1 Heat Pump Models

#### 9.1.1 Delta 25 / DCR 25 Z DCI

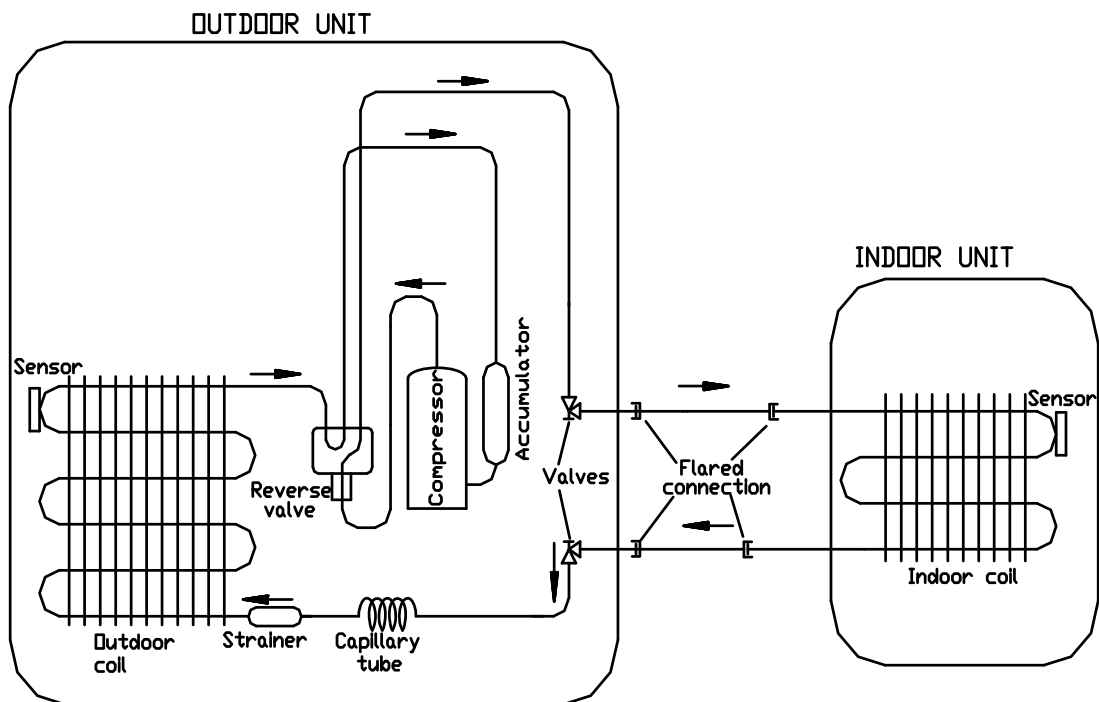
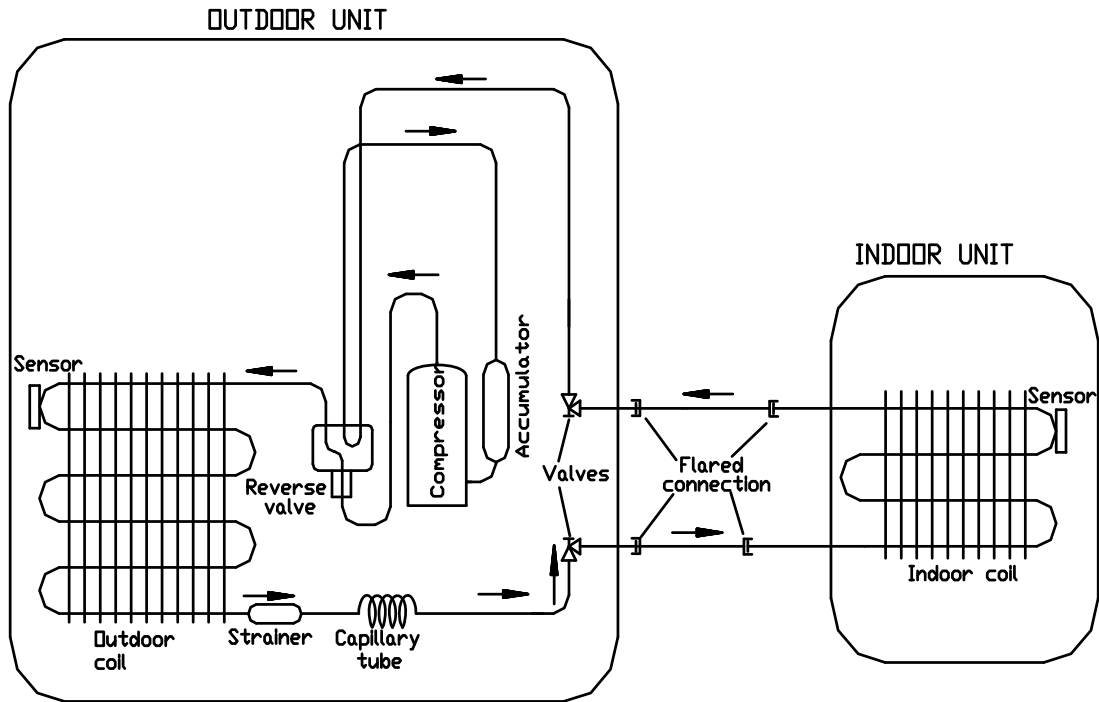

9.1.2 Delta 35 / DCR 35 Z DCI

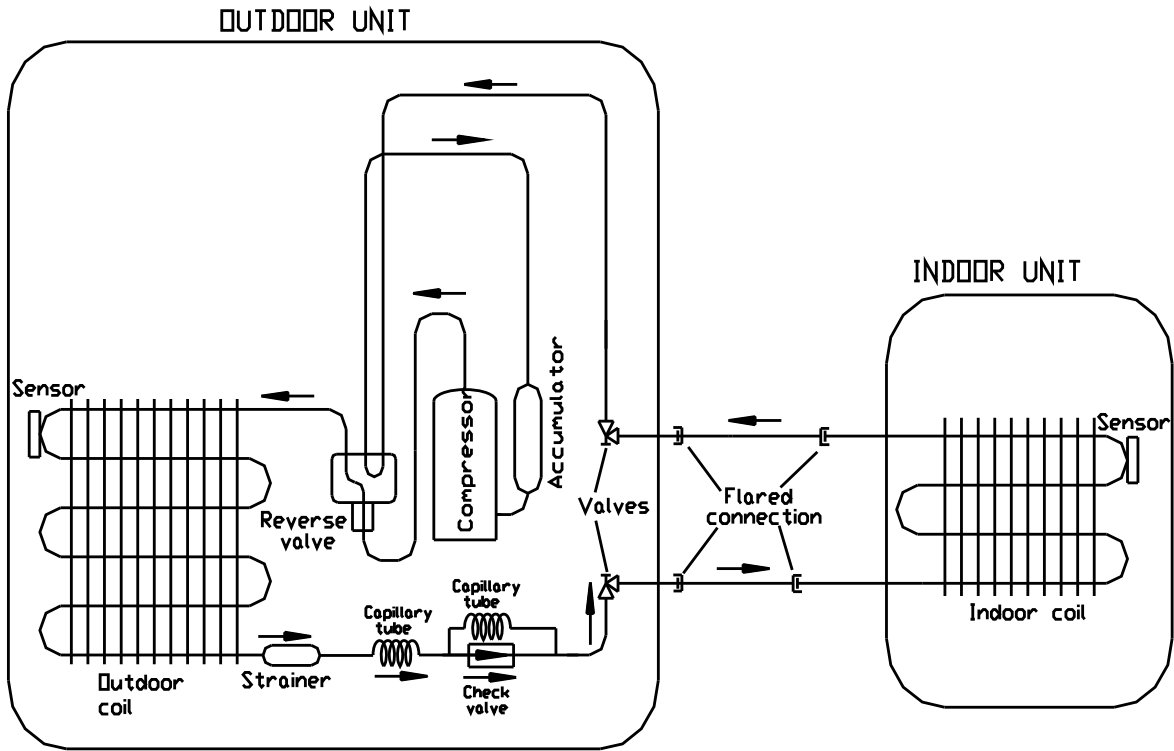

COOLING & DRY MODE

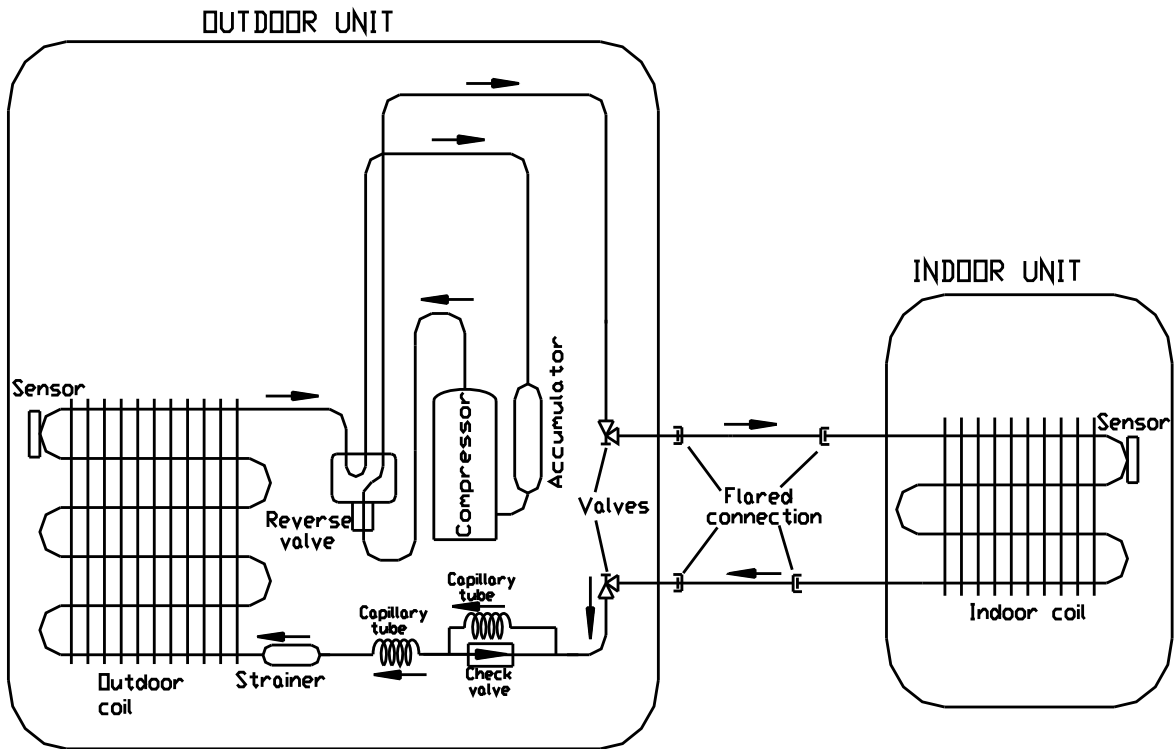

HEATING MODE

# 10. TUBING CONNECTIONS

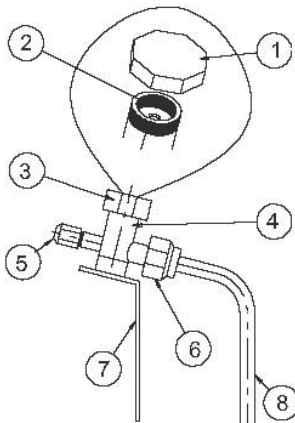
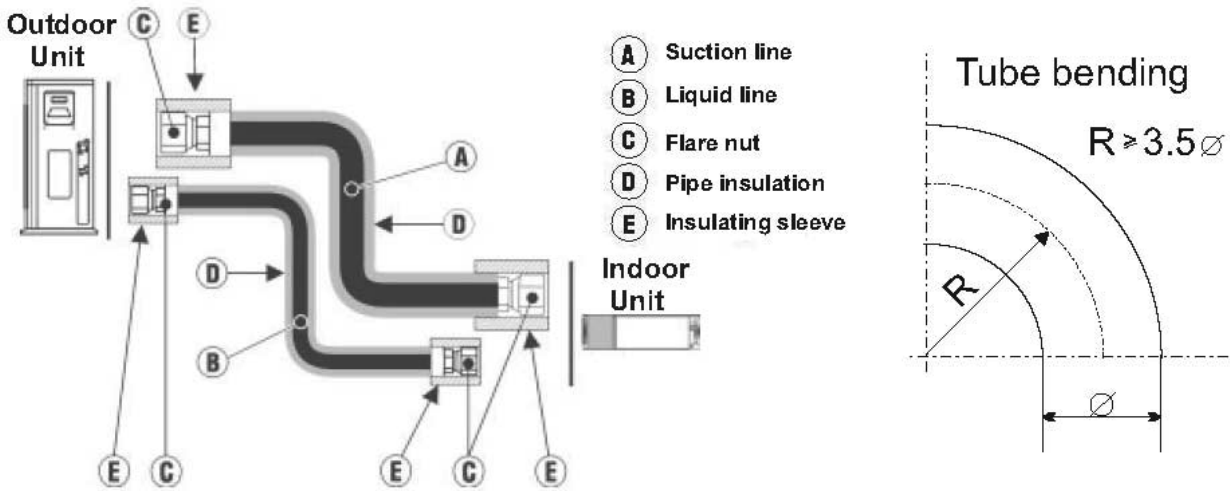

TUBE (Inch)	1/4"	3/8"	1/2"	5/8"	3/4"
<b>TORQUE (Nm)</b>					
<b>Flare Nuts</b>	11-13	40-45	60-65	70-75	80-85
<b>Valve Cap</b>	13-20	13-20	18-25	18-25	40-50
<b>Service Port Cap</b>	11-13	11-13	11-13	11-13	11-13

1. Valve Protection Cap-end
2. Refrigerant Valve Port (use Allen wrench to open/close)
3. Valve Protection Cap
4. Refrigerant Valve
5. Service Port Cap
6. Flare Nut
7. Unit Back Side
8. Copper Tube

When the outdoor unit is installed above the indoor unit an oil trap is required every 5m along the suction line at the lowest point of the riser. In case the indoor unit is installed above the outdoor, no trap is required.

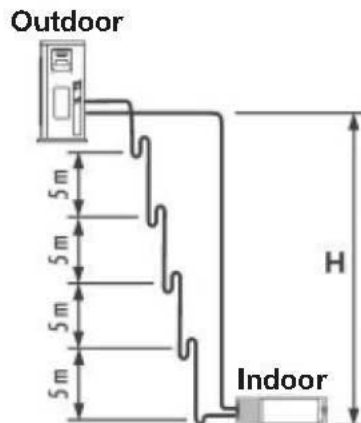

## 11. CONTROL SYSTEM

### 11.1 Electronic Control

#### 11.1.1 General Functions and Operating Rules

The DCI software is fully parametric. All the model dependent parameters are shown in Blue color and with Italic style [*parameter*].

The parameters values are given in the last section of this control logic chapter of the service manual.

#### 11.1.2 System Operation Concept

The control function is divided between indoor and outdoor unit controllers. Indoor unit is the system 'Master', requesting the outdoor unit for cooling/heating capacity supply. The outdoor unit is the system 'Slave' and it must supply the required capacity unless it enters into a protection mode avoiding it from supplying the requested capacity.

**The capacity request is transferred via indoor to outdoor communication, and is represented by a parameter called 'NLOAD'. NLOAD is an integer number with values between 0 and 127, and it represents the heat or cool load felt by the indoor unit.**

#### 11.1.3 Compressor Frequency Control (NLOAD setting)

##### 11.1.3.1 NLOAD setting

The NLOAD setting is done by the indoor unit controller, based on a PI control scheme. The actual NLOAD to be sent to the outdoor unit controller, is based on the preliminary LOAD calculation, the indoor fan speed, and the power shedding function.

NLOAD limits as a function of indoor fan speed:

Indoor Fan Speed	Maximum NLOAD Cooling	Maximum NLOAD Heating
Low	<i>Max NLOADIF1C</i>	127
Medium	<i>Max NLOADIF2C</i>	127
High	<i>Max NLOADIF3C</i>	127
Turbo	<i>Max NLOADIF4C</i>	127
Auto	<i>Max NLOADIF5C</i>	127

##### 11.1.3.2 Target Frequency Setting

The compressor target frequency is set by the following table, according to the NLOAD number received from the indoor unit.

NLOAD	Target Frequency [Hz]	
0	0	
0 < NLOAD ≤ MinFreq	MinFreq	
> MinFreq	$\frac{\text{MaxFreq} - \text{MinFreq}}{\text{LoadDeadZone} - \text{MinFreq}} \cdot \{\min(\text{NLOAD}, \text{LoadDeadZone}) - \text{MinFreq}\} + \text{MinFreq}$	
Definitions		
	Cool	Heat
MinFreq	<i>MinFreqC</i>	<i>MinFreqH</i>
MaxFreq	<i>MaxFreqC</i>	<i>MaxFreqH</i>
LoadDeadZone	<i>LoadDeadZoneC</i>	<i>LoadDeadZoneH</i>

**11.1.3.3 Frequency Changes Control**

Frequency change rate is 1 Hz/sec.

**11.1.3.4 Compressor Starting Control**

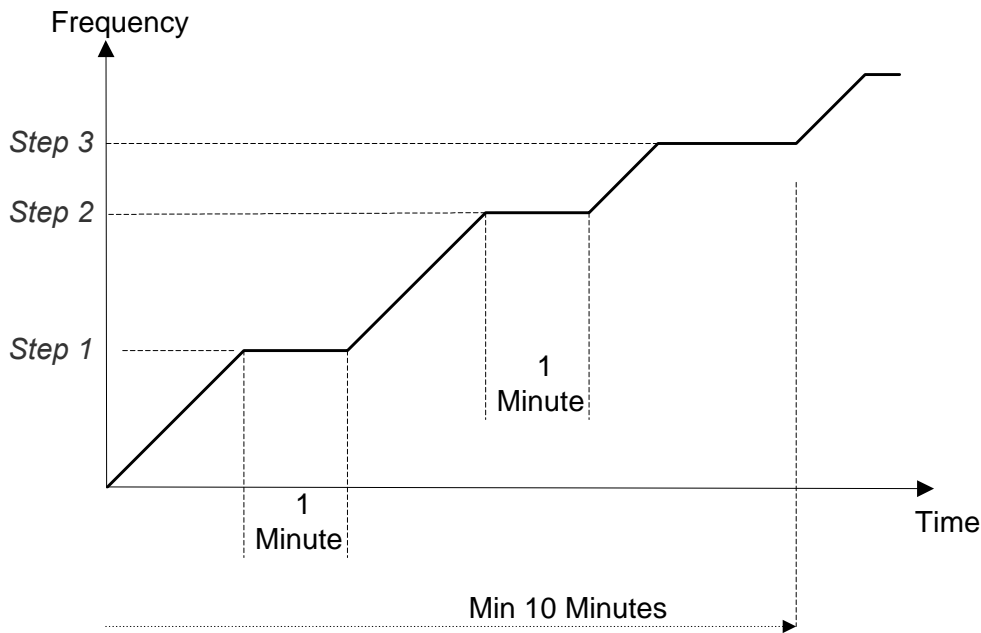

**11.1.3.5 Minimum On and Off Time**

3 minutes.

**11.1.4 Indoor Fan Control**

10 Indoor fan speeds are determined for each model. 5 speeds for cool/dry/fan modes and 5 speeds for heat mode.

When user sets the indoor fan speed to a fixed speed (Low/ Medium/ High), unit will operate constantly at set speed.

When Auto Fan is selected, indoor unit controller can operate in all speeds. The actual speed is set according to the cool/heat load.

**11.1.4.1 Turbo Speed**

The Turbo speed is activated during the first 30 minutes of unit operation when auto fan speed is selected and under the following conditions:

- Difference between set point and actual room temperature is bigger then 3 degrees.
- Room temperature > 22 for cooling, or < 25 for heating.

**11.1.5 Heating Element Control**

Heating element can be started if  $LOAD > 0.8 * MaximumNLOAD$  AND Indoor Coil temperature < 45.

The heating element will be stopped when  $LOAD < 0.5 * MaximumNLOAD$  OR if Indoor Coil temperature > 50.

**11.1.6 Outdoor Fan Control**

**11.1.6.1 The following are the speeds types (General Rules):**

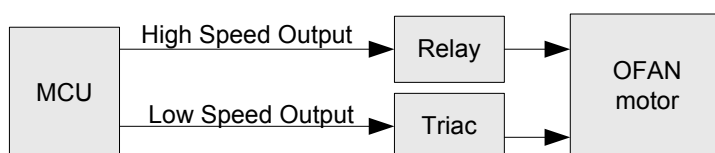

Speed	Controlled by
High	Relay
Low	Triac (40% to 95% effective voltage)

**11.1.6.2 OFAN Operation in Cooling Mode**

With keeping the OFAN general rules above in the highest priority, the operation of the OFAN will be operating as the following:

OAT <sub>Initial</sub>	Time After Compressor start up (minutes)	
	0 – 3min	> 3min
OAT <sub>Initial</sub> >20 (or Faulty)	High(Relay)	<div style="display: flex; align-items: center;"> <div style="margin-right: 20px;">                     High (Relay)                       Low (Triac)- By CDT                 </div> </div> <p style="font-size: small; margin-top: 10px;">Note: OAT faulty , use High Speed</p>
OAT <sub>Initial</sub> ≤20	Low(Triac)- Open Loop	

**Note:**  
 The OAT<sub>Initial</sub> value represents one OAT reading exactly **at the moment start up** (actual freq>0).  
 Low (Triac)- By OMT represents the operation of the Low Fan speed controlled by Triac according to OMT sensor.

**11.1.6.3 OFAN Operation in Heating Mode**

Except to the “General rules”, the outdoor fan will always be running at High speed during heating operation mode.

**11.1.7 EEV (electronic Expansion valve) Control**

EEV opening is defined as  $EEV = EEV_{OL} + EEV_{CV}$

- $EEV_{OL}$  is the initial EEV opening as a function of the compressor frequency, operation mode, unit model and capacity.
- $EEV_{CV}$  is a correction value for the EEV opening that is based on the compressor temperature.
- During the first 5 minutes of compressor operation  $EEV_{CV} = 0$ .
- Once the first 5 minutes are over, the correction value is calculated as follow:  $EEV_{CV}(n) = EEV_{CV}(n-1) + EEV_{CTT}$
- $EEV_{CTT}$  is the correction based on the compressor temperature. A target compressor temperature is set depending on frequency and outdoor air temperature, and the actual compressor temperature is compared to the target temperature to set the required correction to the EEV opening.

### 11.1.8 Reversing Valve (RV) Control

Reversing valve is on in heat mode.

Switching of RV state is done only after compressor is off for over 3 minutes.

### 11.2 Fan Mode

In high/ medium/ low indoor fan user setting, unit will operate fan in selected speed.

In AutoFan user setting, fan speed will be adjusted automatically according to the difference between actual room temperature and user set point temperature.

### 11.3 Cool Mode

NLOAD is calculated according to the difference between actual room temperature and user set point temperature by PI control.

In high/ medium/ low indoor fan user setting, unit will operate fan in selected speed.

In AutoFan user setting, fan speed will be adjusted automatically according to the calculated NLOAD.

### 11.4 Heat Mode

NLOAD is calculated according to the difference between actual room temperature and user set point temperature by PI control.

In high/ medium/ low indoor fan user setting, unit will operate fan in selected speed.

In AutoFan user setting, fan speed will be adjusted automatically according to the calculated NLOAD.

#### 11.4.1 Temperature Compensation

4 degrees are reduced from RT sensor temperature reading (excluding I-Feel mode), to compensate for temperature difference between high and low areas in the heated room, and due to coil heat radiation on RT sensor.

#### 11.4.2 Indoor Fan Control in Heat Mode

Indoor fan speed depends on the indoor coil temperature:

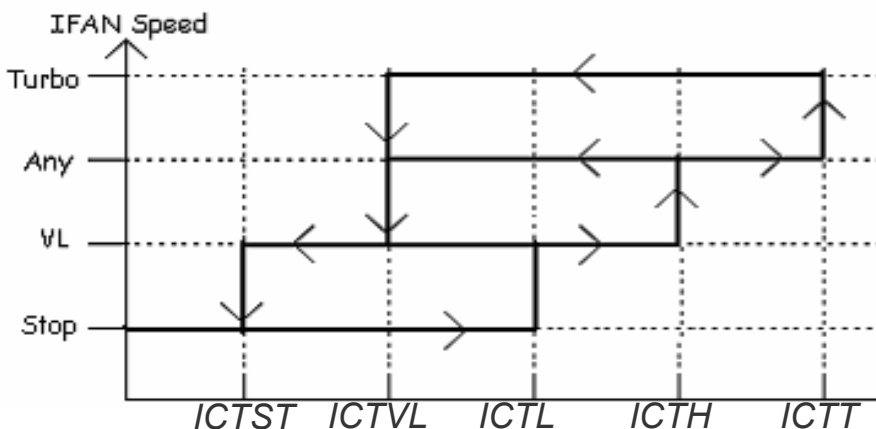

### 11.5 Auto Cool/Heat Mode

When in auto cool heat mode unit will automatically select between cool and heat mode according to the difference between actual room temperature and user set point temperature ( $\Delta T$ ).

Unit will switch from cool to heat when compressor is off for 3 minutes, and  $\Delta T < -3$ .

Unit will switch from heat to cool when compressor is off for 5 minutes, and  $\Delta T < -3$ .



## 11.6 Dry Mode

As long as room temperature is higher than the set point, indoor fan will work in low speed and compressor will work between 0 and *MaxNLOADIF1C* Hz.

When the room temperature is lower than the set point, compressor will be switched OFF and indoor fan will cycle 3 minutes OFF, 1 minute ON.

## 11.7 Protections

There are 5 protection codes.

Normal (Norm) – unit operate normally.

Stop Rise (SR) – compressor frequency can not be raised but does not have to be decreased.

HzDown1 (D1) – Compressor frequency is reduced by *Down1* Hz/min.

HzDown2 (D2) – Compressor frequency is reduced by *Down2* Hz/min.

Stop Compressor (SC) – Compressor is stopped.

### 11.7.1 Indoor Coil Defrost Protection

ICT	ICT Trend				
	Fast Increasing	Increasing	No change	Decreasing	Fast Decreasing
ICT < -2	SC	SC	SC	SC	SC
-2 ≤ ICT < 0	D1	D1	D2	D2	D2
0 ≤ ICT < 2	SR	SR	D1	D2	D2
2 ≤ ICT < 4	SR	SR	SR	D1	D2
4 ≤ ICT < 6	Norm	Norm	SR	SR	D1
6 ≤ ICT < 8	Norm	Norm	Norm	SR	SR
8 ≤ ICT	Normal				

### 11.7.2 Indoor Coil over Heating Protection

ICT	ICT Trend				
	Fast Decreasing	Decreasing	No Change	Increasing	Fast Increasing
ICT > 55	SC	SC	SC	SC	SC
53 < ICT ≤ 55	D1	D1	D2	D2	D2
49 < ICT ≤ 53	SR	SR	D1	D2	D2
47 < ICT ≤ 49	SR	SR	SR	D1	D2
45 < ICT ≤ 47	Norm	Norm	SR	SR	D1
43 < ICT ≤ 45	Norm	Norm	Norm	SR	SR
ICT ≤ 43	Normal				

### 11.7.3 Compressor over Heating Protection

Compressor temperature can be in one of 5 control zones (4 in protection, and 1 normal), according to the following chart.

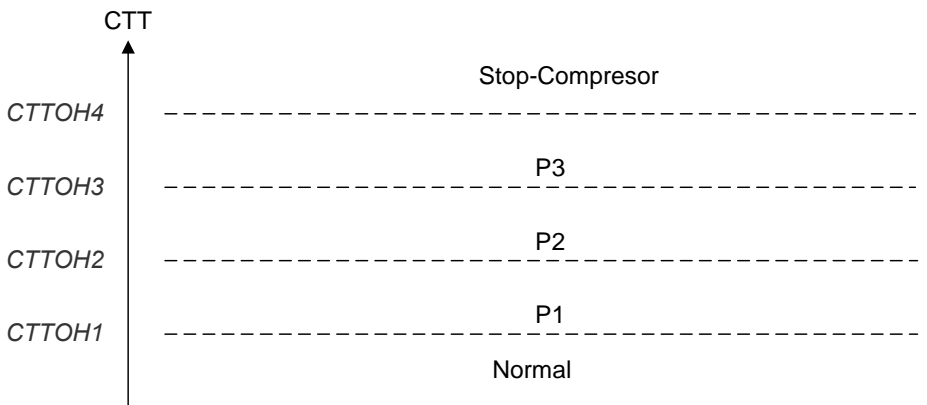

Control Status	Compressor Temperature Increases	Else
P1	Norm	SR
P2	D1	SR
P3	D2	D1
Stop Compressor	SC	

### 11.7.4 Compressor over Current Protection

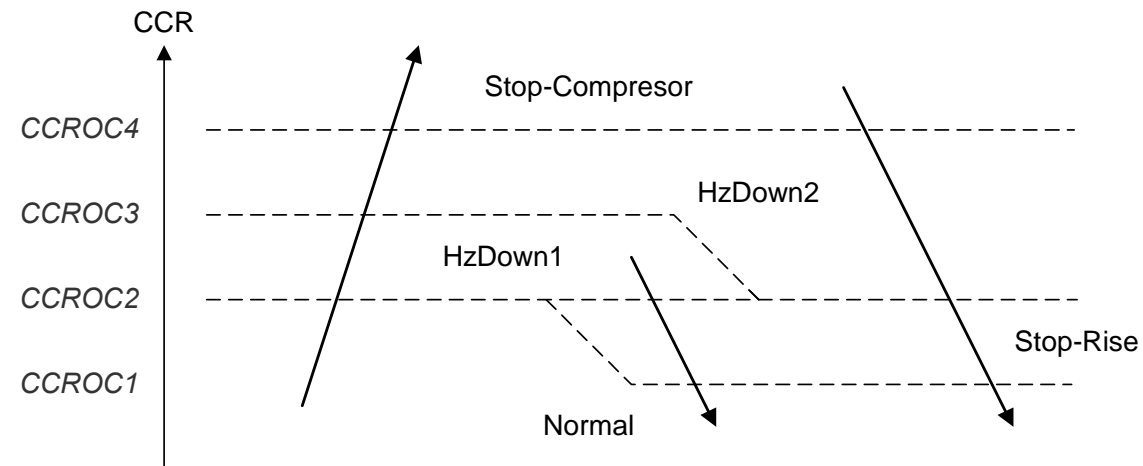

### 11.7.5 Heat Sink Over Heating Protection

A new control status will be set according to the following graph every one-minute or whenever when going up by the rows.

$HST_n$  is the current reading of HST and  $HST_{n-1}$  is the last reading of HST.

HST <sub>n</sub>	HST <sub>n</sub> -HST <sub>n-1</sub>				
	<-1	-1	0	1	>1
$HST_n > HSTOH5$	SC	SC	SC	SC	SC
$HSTOH4 \leq HST_n < HSTOH5$	D1	D1	D2	D2	D2
$HSTOH3 \leq HST_n < HSTOH4$	SR	SR	D1	D2	D2
$HSTOH2 \leq HST_n < HSTOH3$	SR	SR	SR	D1	D1
$HSTOH1 \leq HST_n < HSTOH2$	Norm	Norm	Norm	SR	SR
$HST_n < HSTOH1$	Norm				

(\*) **Normal (Norm)** – No protection status is ON.

**Stop-Rise (SR)** – System is in protection.

**HzDown1 (D1)** - System is in protection.

**HzDown2 (D2)** - System is in protection.

### 11.7.6 Outdoor Coil Deicing Protection

#### 11.7.6.1 Deicing Starting Conditions

Deicing operation will start when either one of the following conditions exist:

- Case 1:  $OCT < -DST - \underline{AND} TLD > DI$
- Case 2:  $OCT < OAT_{max} - 12$  AND  $TLD > 30$  minutes.
- Case 3:  $OCT < -1$  AND  $TLD > 100$  minutes.
- Case 4: OCT is Invalid AND  $TLD > DI$
- Case 5: Unit is just switched to STBY AND  $OCT < -DST$
- Case 6:  $NLOAD = 0$  AND  $OCT < -DST$

DST Calculation:

When  $OAT_{max} > 0$  or OAT is invalid; then  $DST=8$

When  $OAT_{max} \leq 0$ ; then  $DST= \text{round down} (-0.8 * OAT_{max}) + 8$

OATmax calculation:

After compressor starts for 3 minutes, OATmax calculation is start.

The OATmax is the moving value of the Maximum OAT during the 1st 10 minutes within last 30 minutes

OCT – Outdoor Coil Temperature

OAT – Outdoor Air Temperature

TLD – Time from Last Deicing

DI – Deicing Interval (Time Interval Between Two Deicing)

Deicing interval time when compressor is first started in heat mode, is 10 minutes if  $OCT < -2$ , and is 40 minutes in other cases.

Deicing interval time is changed (increased/ decreased in 10 minutes steps) as a function of deicing time. If deicing time is shorter than former deicing time, the deicing interval time will be increased. If deicing time is longer than former deicing time, the deicing interval time will be decreased.

**11.7.6.2 Deicing Protection Procedure**

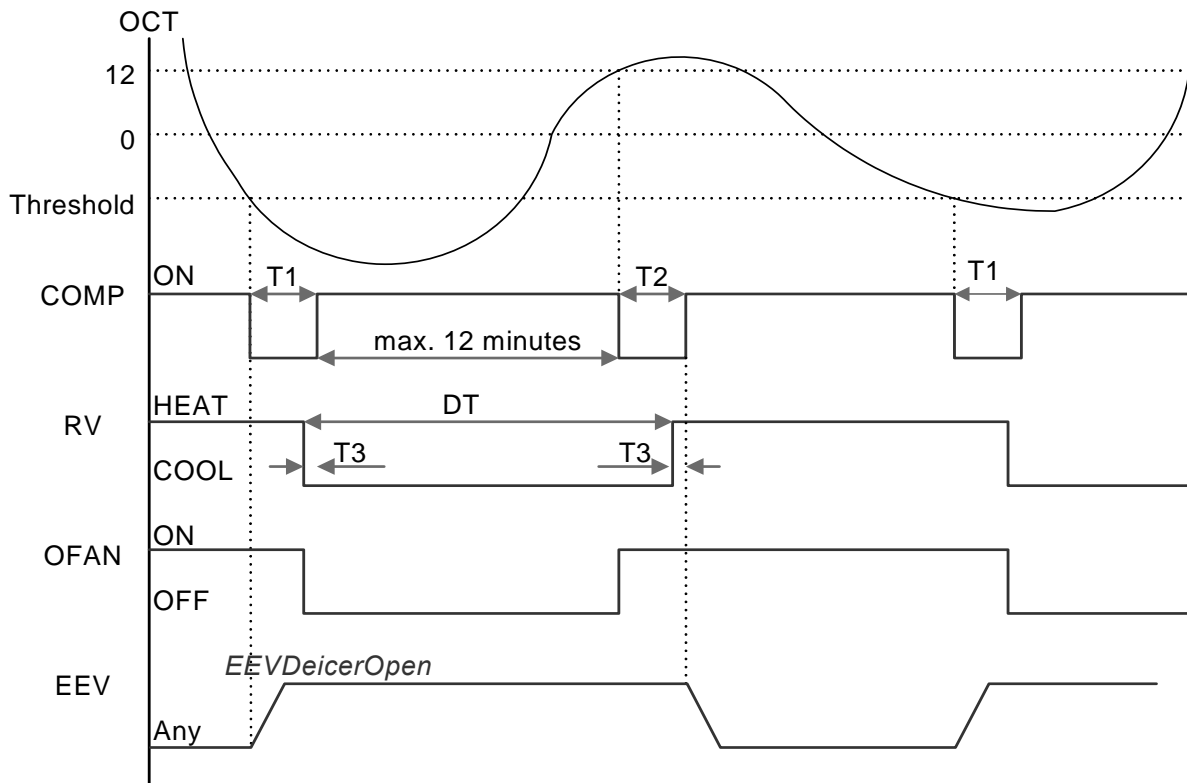

T1 = DEICT1, T2 = DEICT2, T3 = DEICT3

**11.7.7 Condensate Water Over Flow Protection**

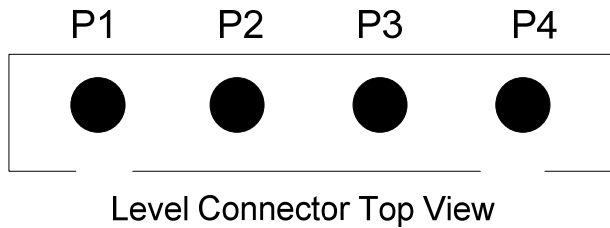

Each of the pins P1, P2, P3 can have two options:

1 – When it is shorted with P4

0 – When it is not shorted to P4

**11.7.7.1 3 Levels Logic (used in floor/ceiling models)**

P2	P3	Level
0	0	L0
1	0	L1
1	1	L2&3
0	1	L4

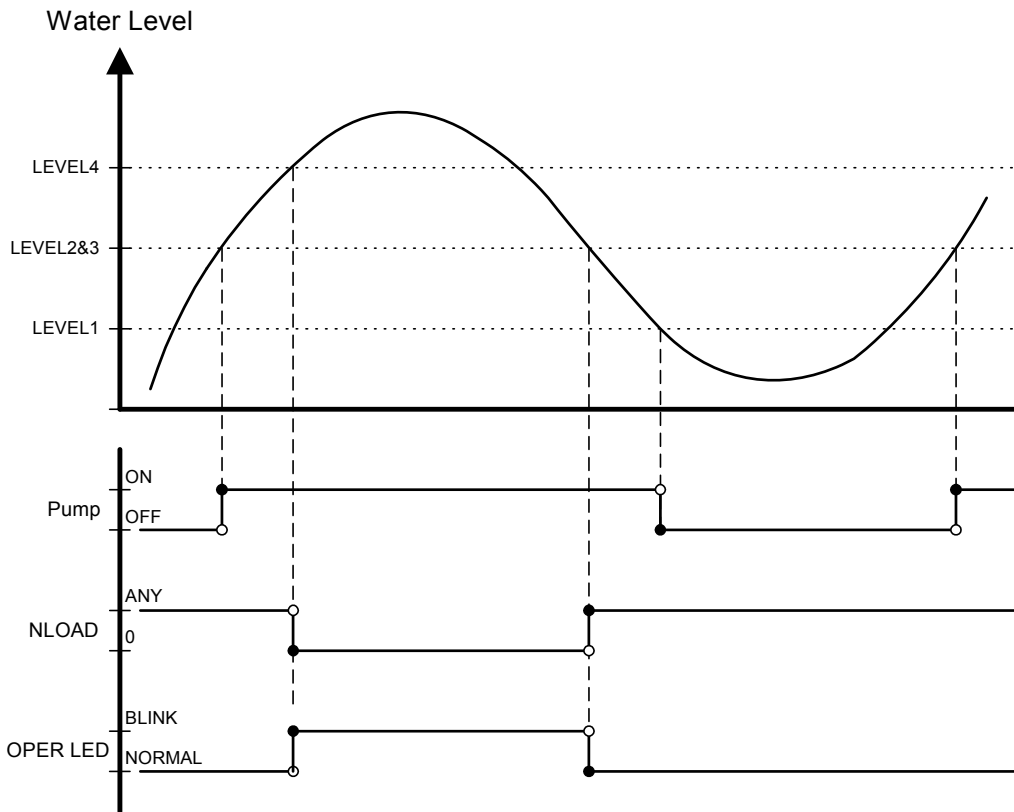

11.7.7.2 1 Level Logic (used in all models except for floor/ceiling models)

P2	P3	Level
Don't care	1	Normal
Don't care	0	Overflow

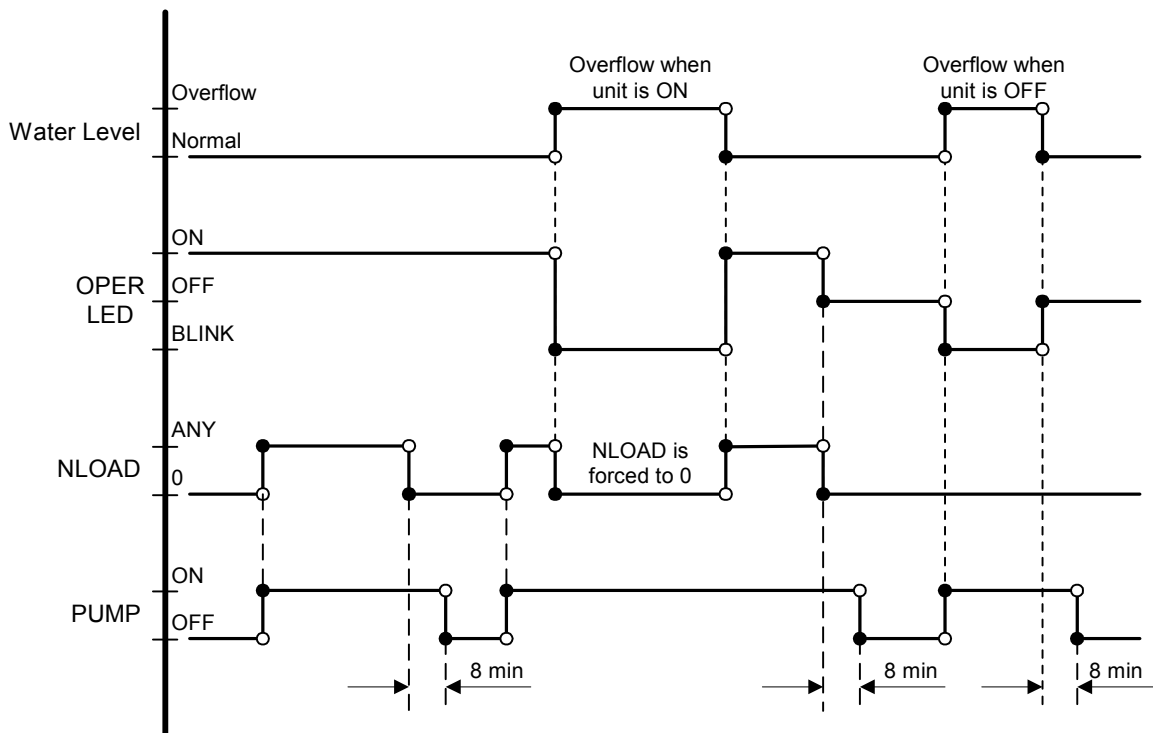

### 11.8 Indoor Unit Dry Contact

Indoor unit Dry contact has two alternative functions that are selected by J8.

	Function	Contact = Open	Contact = Short
J8 = Open	Presence Detector Connection	No Limit	Forced to STBY
J8 = Short	Power Shedding Function	No Limit	Limit NLOAD

### 11.9 Operating the Unit from the Mode Button

Forced operation allows to start, stop and operate in Cooling or Heating, in pre-set temperature according to the following table:

Forced operation Mode	Pre-set Temperature
Cooling	20°C
Heating	28°C

### 11.10 On Unit Controls and Indicators

#### 11.10.1 Indoor Unit Controller Controls and Indicators Foe All Models

The following is schematic drawing for the display:

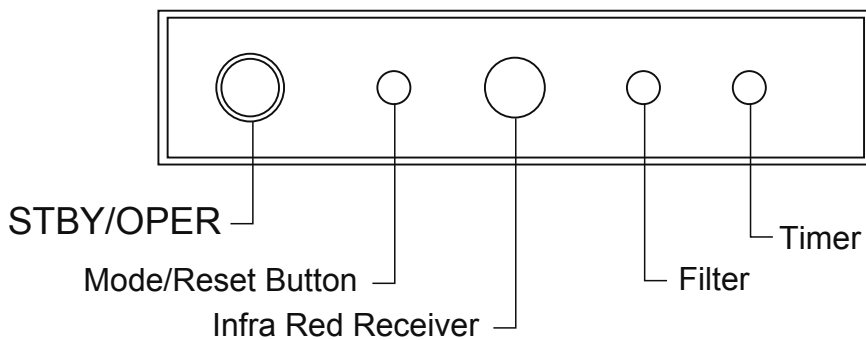

<p><b>STAND BY INDICATOR</b></p>	<ol style="list-style-type: none"> <li>1. Lights up when the Air Conditioner is connected to power and the mode is STBY.</li> <li>2. Blinks for 3 seconds, when the system is switched to Heat Mode by using the Mode/Reset Switch on the unit (the operation indicator will be off during this blinking time).</li> </ol>
<p><b>OPERATION INDICATOR</b></p>	<ol style="list-style-type: none"> <li>1. Lights up during operation mode (except for item in STBY indicator).</li> <li>2. Blinks for 300 msec., to announce that a R/C infrared signal has been received and stored.</li> <li>3. Blinks continuously during protections (according to the relevant spec section).</li> <li>4. Blinks for 3 seconds when the system is switched to Cool Mode by using the Mode/Reset Switch on the unit.</li> </ol>
<p><b>TIMER INDICATOR</b></p>	<p>Lights up during Timer and Sleep operation.</p>
<p><b>FILTER INDICATOR</b></p>	<p>Lights up when Air Filter needs to be cleaned.</p>
<p><b>MODE / RESET BUTTON</b></p>	<p>As long as the filter Led is off, the Mode/Reset button functions as Mode switch. Once filter Led is on, the Mode/Reset button functions as Reset switch.</p> <p><u>Mode Function:</u>                      Every short pressing , the next operation mode is selected, in this order:                      SB → Cool Mode → Heat Mode → SB → ...                      In long pressing system enters diagnostic mode (refer to diagnostic mode Sect.)</p> <p><u>Reset Function:</u>                      For short pressing:                      When Filter LED is on, it turns off the filter indicator.</p>

**Notes**

1. Pressing time is defined as the time between press and release.
2. If pressing time is one second or less – press is considered as short pressing.
3. If pressing time is three seconds or longer – pressing is considered as long pressing. In between, pressing is undetermined and system will not respond to pressing.
4. For the LED functionality during diagnostics, refer to the diagnostics Sect.

## 11.10.2 Outdoor Unit Controller Indicators

Unit has three LED's. SB LED, STATUS LED, FAULT LED.

SB LED is ON when power is ON (230 VAC),

STATUS LED is ON when COMP is ON, and Blinks according to diagnostics mode definitions when either fault or protection occurs.

FAULT LED Blinks according to diagnostics mode definitions when either fault or protection occurs.

## 11.11 Jumper Settings

### 11.11.1 Indoor Unit Controller

#### 11.11.1.1 Hardware Jumpers

0 = Open Jumper (disconnect jumper).

1 = Close Jumper (connect jumper).

#### Self test Jumper – J1

OPERATION	J1
SELF-TEST	1
NORMAL	0

#### Family selection Jumper – J2

Family	J2
Delta 22/25/35	0
Delta 50	1

#### Model selection Jumper – J3, J4

Model	J3	J4
A	0	0
B	0	1
C	1	0
D	1	1

#### 11.11.1.2 Software Jumpers

Property	0	1
EEPROM DATA (J1)	Use ROM*	Use EEPROM
'Thermostatic Stop- Heat' (J2)	Deactivated	Activated
'Heat to STBY' (J3)	Deactivated	Activated
Enable Test Mode (J4)	Deactivated	Activated*

\* Default values (used in the ROM)

Default SW jumpers according to the family (used in the ROM)

Property	Delta 22/25/35	Delta 50
'Thermostatic Stop- Heat' (J2)	1	1
'Heat to STBY' (J3)	1	1

#### J1 – EEPROM/ROM setting

When J1 is 1, IDU will use model/family/general parameters from EEPROM. If EEPROM is invalid, IDU will ignore J1 and use/copy the ROM pointed by the selected jumpers (will also set an according fault).



## 11.11.2 Outdoor Unit Controller

### 11.11.2.1 Hardware Jumpers

JP9 JUMPER LAYOUT

<b>EEPROM Data</b> (PIN 9)	<b>ODU3</b> (PIN 7)	<b>ODU2</b> (PIN 5)	<b>ODU1</b> (PIN 3)	<b>ODU0</b> (PIN 1)
<b>GND</b> (PIN 10)	<b>GND</b> (PIN 8)	<b>GND</b> (PIN 6)	<b>GND</b> (PIN 4)	<b>GND</b> (PIN 2)

ODU MODEL SELECTION

ODU3	ODU2	ODU1	ODU0	ODU Model	Compressor Type
OFF	OFF	OFF	OFF	Reserved	
OFF	OFF	OFF	ON	A (Single DCR 22- Use Capillary)	Toshiba-DA89 (4 Poles)
OFF	OFF	ON	OFF	B (Single DCR 25- Use Capillary)	Toshiba-DA89 (4 Poles)
OFF	OFF	ON	ON	C (Single DCR 35- Use Capillary)	Toshiba- DA108 (4 Poles)
OFF	ON	OFF	OFF	D (Reserved)	
OFF	ON	OFF	ON	E (Single DCR 22- Use EEV)	Panasonic-5RS092 (6 Poles)
OFF	ON	ON	OFF	F (Single DCR 25- Use EEV)	Panasonic-5RS092 (6 Poles)
OFF	ON	ON	ON	G (Single DCR 35- Use EEV)	Panasonic-5RS102(6 Poles)
ON	OFF	OFF	OFF	H	
ON	OFF	OFF	ON	I	
ON	OFF	ON	OFF	J	
ON	OFF	ON	ON	K	
ON	ON	OFF	OFF	L	
ON	ON	OFF	ON	M	
ON	ON	ON	OFF	N	
ON	ON	ON	ON	O	

PCB JUMPER SETTING FOR J2 HEAD

<b>RXD</b> (PIN 2)	<b>TEST</b> (PIN 4)	<b>GND</b> (PIN 6)
<b>VCC</b> (PIN 1)	<b>N/C</b> (PIN 3)	<b>TXD100</b> (PIN 5)

1. Connect **PIN 4** and **PIN 6** to enter Built-in-Test.
2. RXD, TXD100, VCC is for MegaTools connection.

PCB JUMPER J1 HEADER

J1 header is used for program flash.

### 11.11.2.2 Software Jumpers

Property	0	1
EEPROM DATA (J1)	Use ROM*	Use EEPROM

\* Default values (used in the ROM)

#### J1 – EEPROM/ROM setting

When J1 is 1, ODU will use model/general parameters from EEPROM. If EEPROM is invalid, ODU will ignore J1 and use/copy the ROM pointed by the selected jumpers (will also set an according fault).

## 11.12 Test Mode

### 11.12.1 Entering Test Mode

System can enter Test mode in two ways:

- Automatically when the following conditions exists for 30 minutes continuously:
  - Mode = Cool, Set point = 16, Room temperature =  $27\pm 1$ , Outdoor temperature =  $35\pm 1$
- Or
  - Mode = Heat, Set point = 30, Room temperature =  $20\pm 1$ , Outdoor temperature =  $7\pm 1$
- Manually when entering diagnostics with the following settings:
  - - Mode = Cool, Set point = 16
    - Mode = Heat, Set point = 30

### 11.12.2 Unit Operation in Test Mode

In test mode, the unit will operate in fixed settings according to the indoor fan speed setting:

Indoor Fan Speed Setting	Unit Setting
Low	Minimum Capacity Setting
High	Nominal Capacity Setting
Auto	Maximum Capacity Setting

During test mode, protections are disabled, except for stop compressor status.

## 11.13 SW Parameters

### 11.13.1 Indoor Units SW Parameters

#### 11.13.1.1 General Parameters for All Models:

**Parameters defining the indoor fan speed as a function of Indoor Coil temperature in heat mode (ICT):**

ICTST Speed	ICT to stop indoor fan	25
ICTVLSpeed	ICT to go down to very low speed	28
ICTLSpeed	ICT to start in very low speed	30
ICTHSpeed	ICT to start in increase speed from very low	32
ICTTSpeed	ICT to enable Turbo fan speed	40

**Parameters for defrost protection:**

ICTDef1	ICT to go back to normal	8
ICTDef2	ICT to 'stop rise' when ICT decrease	6
ICTDef3	ICT to 'stop rise' when ICT is stable	4
ICTDef4	ICT to 'Hz Down' when ICT decrease	2
ICTDef5	ICT to 'Hz Down' when ICT is stable	0
ICTDef6	ICT to stop compressor	-2

**Parameters for indoor coil over heating protection:**

ICTOH1	ICT to go back to normal	45
ICTOH2	ICT to 'stop rise' when ICT increase	48
ICTOH3	ICT to 'stop rise' when ICT is stable	52
ICTOH4	ICT to 'Hz Down' when ICT increase	55
ICTOH5	ICT to 'Hz Down' when ICT is stable	60
ICTOH6	ICT to stop compressor	62

**11.13.1.2 Model Depended Parameters:**

Parameter name	Models	
	25	35
NLOAD limits as a function of selected indoor fan speed		
MaxNLOADIF1C	40	40
MaxNLOADIF2C	51	55
MaxNLOADIF3C	90	90
MaxNLOADIF4C	127	127
MaxNLOADIF5C	127	127
Indoor Fan speeds		
IFVLOWC	700	700
IFLOWC	850	850
IFMEDC	1050	1000
IFHIGHC	1200	1200
IFTURBOC	1300	1300
IFVLOWH	700	700
IFLOWH	950	950
IFMEDH	1050	1100
IFHIGHH	1250	1250
IFTURBOH	1350	1300
Nominal Compressor Frequency		
NomLoadC	51	61
NomLoadH	58	62

**11.13.2 Outdoor Units SW Parameters**

Parameter Name	DCR 25 Z	DCR 35 Z
Compressor Parameters		
MinFreqC	25	25
MaxFreqC	65	78
MinFreqH	28	28
MaxFreqH	67	75
Step1Freq	43	45
Step2Freq	55	55
Step3Freq	63	65
Frequency limits as a function of outdoor air temperature		
MaxFreqAsOATC	65	78
MaxFreqAsOAT1H	58	60
MaxFreqAsOAT2H	50	50
Compressor Over Heating Protection		
CTTOH1	94	94
CTTOH2	98	98
CTTOH3	102	102
CTTOH4	105	105
CTTOH5	120	120
Compressor Over Current Protection [A]		
CCR01	35	40
CCR02	37	42
CCR03	39	44
CCR04	42	47
Outdoor Fan Speed (RPM)		
OFLOWC		
OFMEDC		
OFMAXC	830	830

## 12 TROUBLESHOOTING

### 12.1 ELECTRICAL & CONTROL TROUBLESHOOTING

**WARNING!!!**

When Power Up – the whole outdoor unit controller, including the wiring, is under HIGH VOLTAGE!!!

Never open the Outdoor unit before turning off the Power!!!  
When turned off, the system is still charged (400V)!!!  
It takes about 4 Min. to discharge the system.  
Touching the controller before discharging may cause an electrical shock!!!

**For safe handling of the controller please refer to section 12.3 below.**

#### 12.1.1 Single Split system failures and corrective actions

No	SYMPTOM	PROBABLE CAUSE	CORRECTIVE ACTION
1	Power supply indicator (Red LED) does not light up.	No power supply	Check power supply. If power supply is OK, check display and display wiring. if OK, replace controller.
2	Unit does not respond to remote control message	Remote control message not reached the indoor unit	Check remote control batteries, if batteries are OK, check display and display wiring, if OK, replace display PCB. If still not OK replace controller.
3	Unit responds to remote control message but Operate indicator (Green LED) does not light up	Problem with display PCB	Replace display PCB. If still not OK replace controller.
4	Indoor fan does not start (louvers are opened and Green LED does light up)	Unit in heat mode and coil is still not warm.	Change to cool mode and check.
		Problem with PCB or capacitor	Change to high speed and Check power supply to motor is higher than 130VAC (for triack controlled motor) or higher than 220VAC for fixed speed motors, if OK replace capacitor, if not OK replace controller
5	Indoor fan works when unit is OFF, and indoor fan speed is not changed by remote control command.	PCB problem	Replace controller
6	Compressor does not start	Electronics control problem or protection	Perform diagnostics (See 12.1.3 below), and follow the actions described.
7	Compressor stops during operation and Green LED remains on	Electronic control or power supply problem	Perform diagnostics (See 12.1.3 below), and follow the actions described.
8	Compressor is on but outdoor fan does not work	Problem with outdoor electronics or outdoor fan	Check outdoor fan motor according to the procedure in section 12.2.3 below, if not OK replace controller
9	Unit works in wrong mode (cool instead of heat or heat instead of cool)	Electronics or power connection to RV	Check RV power connections, if OK, Check RV operation with direct 230VAC power supply, if OK, Replace outdoor controller.
10	All components are operating properly but no cooling or no heating	Refrigerant leak	Check refrigeration system.

No	SYMPTOM	PROBABLE CAUSE	CORRECTIVE ACTION
11	Compressor is over heated and unit does not generate capacity	EEV problem	Check EEV
12	Units goes into protections and compressor is stopped with no clear reason	Control problem or refrigeration system problem	Perform diagnostics (See 13.1.3 below), and follow the actions described.
13	Compressor motor is generating noise and no suction occurs	Phase order to compressor is wrong	Check compressor phase order.
14	Water leakage from indoor unit	Indoor unit drainage tube is blocked	Check and open drainage tube.
15	Freezing of outdoor unit in heat mode and outdoor unit base is blocked with ice		Connect base heater.
16	Unit operates with wrong fan speeds or wrong frequency	Wrong jumper settings	Perform diagnostics (See 12.1.3 below), and check if units is operating by EEPROM parameters.

### 12.1.2 Checking the refrigeration system

Checking system pressures and other thermodynamic measures should be done when system is in Test Mode (in Test mode, system operates in fixed settings). The performance curves given in this manual are given for unit performance in test mode when high indoor fan speed is selected.

Entering test mode:

Set unit to Cool/16 degrees/High indoor fan speed, or Heat/30 degrees/High indoor fan speed, and enter diagnostics.

### 12.1.3 Judgment by Indoor/Outdoor Unit Diagnostics

Enter diagnostics mode - press for five seconds Mode/Reset button in any operation mode. Acknowledgment is by 3 short beeps and lights of all Display LED's. Then, The units will enter into Indoor and Outdoor unit diagnostic modes.

During the Outdoor unit diagnostics all three Indoor LED's (STBY/Operate, Filter and Timer) are blinking. When Indoor diagnostics is displayed, all three LED's (STBY/Operate, Filter and Timer) are ON.

When system enters diagnostics mode, only one fault code is shown. Order of priority is from the lower to the higher number. Diagnostics is continuously ON as long as power is ON. The current system operation mode will not be changed.

If no fault occurred in the system, no fault code will be displayed during normal operation MOde. The last fault code will be displayed even if the system has recovered from that fault. The last fault will be deleted from the EEPROM after the system has exit diagnostics mode.

In diagnostics mode, system fault / status will be indicated by blinking of Filter & Timer LEDs.

The coding method will be as follows:

Filter LED will blink 5 times in 5 seconds, and then will be shut off for the next 5 seconds.

Timer LED will blink during the same 5 seconds according to the following Indoor / Outdoor unit tables:

Note: 0 – OFF, 1-ON

**12.1.3.1 Indoor unit Diagnostics**

No	Problem	5	4	3	2	1
1	RT-1 is disconnected	0	0	0	0	1
2	RT-1 is shorted	0	0	0	1	0
3	RT-2 is disconnected	0	0	0	1	1
4	RT-2 is shorted	0	0	1	0	0
5	Reserved	0	0	1	0	1
7	Communication mismatch	0	0	1	1	1
8	No Communication	0	1	0	0	0
9	No Encoder	0	1	0	0	1
10	Reserved	0	1	0	1	0
11	Outdoor Unit Fault	0	1	0	1	1
...	Reserved					
17	Defrost protection	1	0	0	0	1
18	Deicing Protection	1	0	0	1	0
19	Outdoor Unit Protection	1	0	0	1	1
20	Indoor Coil HP Protection	1	0	1	0	0
21	Reserved	1	0	1	0	1
22	Reserved					
24	EEPROM Not Updated	1	1	0	0	0
25	Bad EEPROM	1	1	0	0	1
26	Bad Communication	1	1	0	1	0
27	Using EEPROM data	1	1	0	1	1
28	Model A	1	1	1	0	0
29	Model B	1	1	1	0	1
30	Model C	1	1	1	1	0
31	Model D	1	1	1	1	1

**13.1.3.2 Indoor unit diagnosis and corrective actions**

No.	Fault	Probable Cause	Corrective Action
1	Sensor failures of all types		Check sensor connections or replace sensor
2	Communication mismatch	Indoor and Outdoor controllers are with different versions	Replace Indoor controller
3	No Communication	Communication or grounding wiring is not good.	Check Indoor to Outdoor wiring and grounding
4	No Encoder	Indoor electronics or motor	Check motor wiring, if ok, replace motor, if still not ok, replace Indoor controller.
5	Outdoor Unit Fault	Outdoor controller problem	Switch to Outdoor diagnostics.
6	EEPROM Not Updated	System is using ROM parameters and not EEPROM parameters	No action, unless special parameters are required for unit operation.
7	Bad EEPROM		No action, unless special parameters are required for unit operation.
8	Bad Communication	Communication quality is low reliability	Check Indoor to Outdoor wiring and grounding
9	Using EEPROM data	No problem. System is using EEPROM parameters	

### 13.1.3.3 Outdoor unit Diagnostics

DCR 22 / 25 / 35 diagnostics

No	Problem	5	4	3	2	1
1	OCT shorted/disconnected	0	0	0	0	1
2	CTT shorted/disconnected	0	0	0	1	0
3	HST shorted/disconnected	0	0	0	1	1
4	OAT shorted/disconnected	0	0	1	0	0
5	OMT shorted/disconnected	0	0	1	0	1
...	Reserved					
11	IPM Fault	0	1	0	1	1
12	Reserved	0	1	1	0	0
13	DC under voltage	0	1	1	0	1
14	Reserved	0	1	1	1	0
15	Zero Crossing detection fault	0	1	1	1	1
16	Mismatch between IDU & ODU models	1	0	0	0	0
17	No Communication	1	0	0	0	1
...	Reserved					
20	Heat sink Over Heating	1	0	1	0	0
21	Deicing	1	0	1	0	1
22	Compressor Over Heating	1	0	1	1	0
23	Compressor Over Current	1	0	1	1	1
...	Reserved					
26	Copressor Lock	1	1	0	1	0
27	Bad Communication	1	1	0	1	1
28	Missing ODU configuration	1	1	1	0	0
29	Undefined ODU Model	1	1	1	0	1
30	Outdoor Coil Overheating	1	1	1	1	0
31	Operation condition is exceeded	1	1	1	1	1

### 12.1.3.4 Outdoor unit diagnosis and corrective actions

No.	Fault	Probable Cause	Corrective Action
1	Sensors failures of all types		Check sensors connections or replace sensors.
2	IPM Fault	Electronics HW problem	Check all wiring and jumper settings, if OK, replace electronics.
3	Bad EEPROM		No action, unless special parameters are required for unit operation.
4	DC under/over Voltage	Electronics HW problem	Check outdoor unit power supply voltage
5	AC under Voltage		Check outdoor unit power supply voltage
6	Indoor / Outdoor unit Communication mismatch	Indoor and Outdoor controllers are with different versions	Replace Indoor controller
7	No Communication	Communication or grounding wiring is not good.	Check Indoor to Outdoor wiring and grounding
8	Compressor Lock		Switch unit to STBY and restart
9	Bad Communication	Communication quality is low reliability	Check Indoor to Outdoor wiring and grounding

### 12.1.4 Judgement by MegaTool

MegaTool is a special tool to monitor the system states.

Using MegaTool requires:

- A computer with RS232C port.
- A connection wire for MegaTool.
- A special MegaTool software.

Use MegaTool according to following procedure:

- Setup MegaTool software: copy the software to the computer.
- Connect RS232C port in computer with MegaTool port in Indoor/Outdoor unit controller by the connection wire.
- Run the software and choose the COM port, you can monitor the A/C system state in monitor tab.

## 12.2 Simple procedures for checking the Main Parts

### 12.2.1 Checking Mains Voltage.

Confirm that the Mains voltage is between 198 and 264 VAC. If Mains voltage is out of this range, abnormal operation of the system is expected. If in range check the Power (Circuit) Breaker and look for broken or loosed cable lugs or wiring mistake(s).

### 12.2.2 Checking Power Input.

If Indoor unit power LED is unlighted, power down the system and check the fuse of the Indoor unit. If the fuse is OK replace the Indoor unit controller. If the fuse has blown, replace the fuse and power up again.

Checking Power Input procedure for the Outdoor unit is the same as with the Indoor unit.

### 12.2.3 Checking the Outdoor Fan Motor.

Enter Test Mode (where the OFAN speed is high)

check the voltage between two pins( Hi and N ) of connector Controller OFAN, normal voltage is 220VAC.

### 12.2.4 Checking the Compressor.

The compressor is brushless permanence magnetic DC motor. Three coil resistance is same. Check the resistance between three poles. The normal value should be below 0.5 ohm (TBD).

**Pay attention U,V, Ware respective to connect to RED, BROWN, BLACK wires.**

### 12.2.5 Checking the Reverse Valve (RV).

Running in heating mode, check the voltage between two pins of reverse valve connector, normal voltage is 220VAC.

## 12.3 Precaution, Advise and Notice Items

### 12.3.1 High voltage in Outdoor unit controller.

Whole controller, including the wires that are connected to the Outdoor unit controller may have the potential hazard voltage when power is on. Touching the Outdoor unit controller may cause an electrical shock.

**Advise:** Don't touch the naked lead wire and don't insert finger, conductor or anything else into the controller when power is on.

### 12.3.2 Charged Capacitors

Three large-capacity electrolytic capacitors are used in the Outdoor unit controller. Therefore, charging voltage (380VDC) remains after power down. Discharging takes about four minutes after power is off. Touching the Outdoor unit controller before discharging may cause an electrical shock.

### 12.3.3 Additional advises

- When disassemble the controller or the front panel, turn off the power supply.
- When connecting or disconnecting the connectors on the PCB, hold the whole housing, don't pull the wire.

There are sharp fringes and sting on shell. Use gloves when disassemble



**13. EXPLODED VIEWS AND SPARE PARTS LISTS**

**13.1 Indoor Unit: Delta 25, Delta 35 DCI**

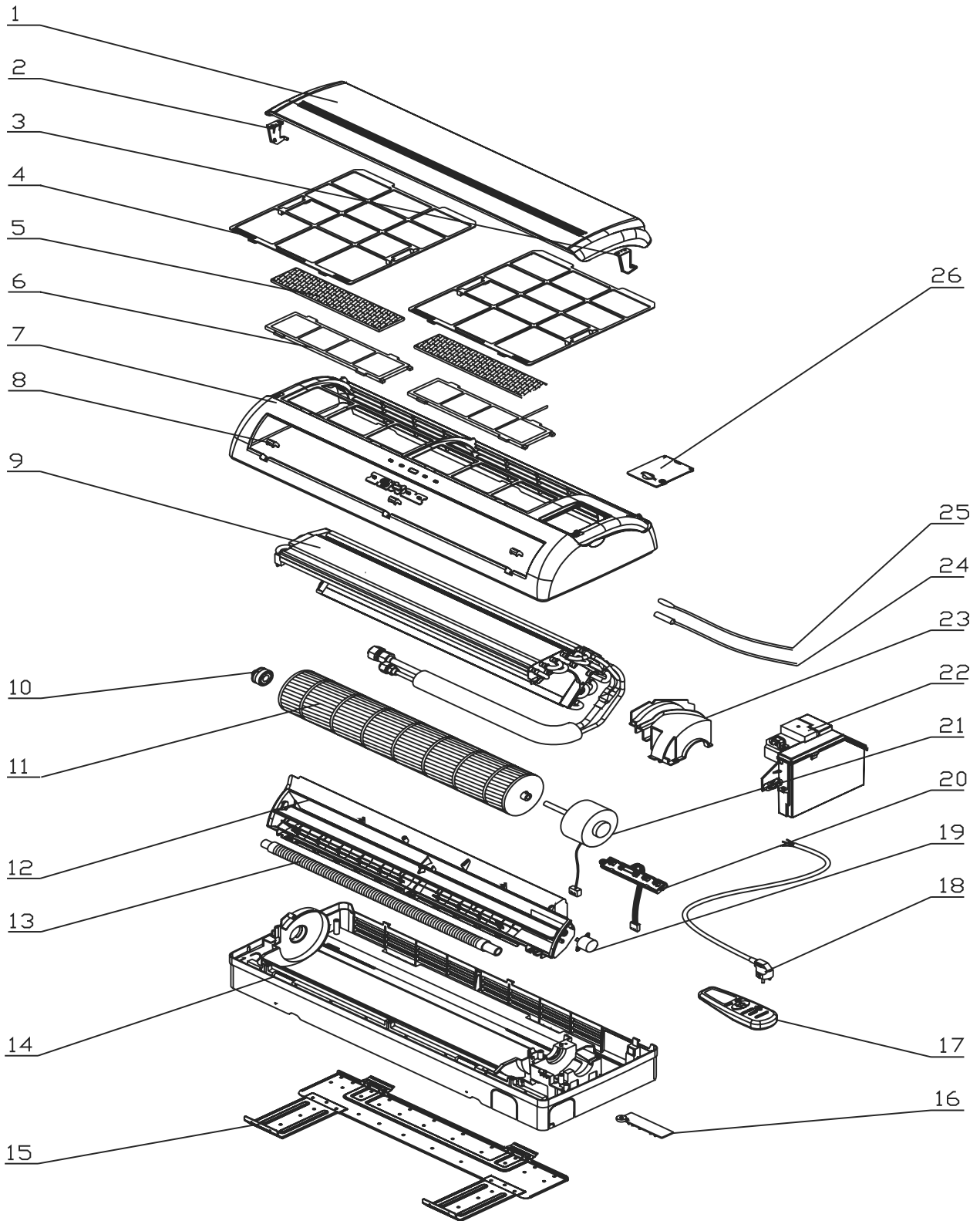

### 13.2 Indoor Unit: Delta 25 DCI

No.	Part No.	Description	Quan.
1	453037000	Grill A / DELTA 22,25	1
2	453100500	Grill L axis	1
3	453100600	Grill R axis	1
4	453036500	Filter for DELTA 7/9	2
7	465720000	Silk-screen front frame for Electra	1
8	4525987	SCREW COVER	3
9	453070701	Evap. System Assy./DELTA 22,25	1
10	4523526	BERAING ASSY FAN	1
11	4523523	FAN ASSY PLASTIC	1
12	452784400	IOD-7,9 Air Outlet Assy. (no wire)	1
13	4523693	DRAIN HOSE	1
14	4526659	REAR PANEL ASSY	1
15	453027400	Mount Bracket Assy./Alfa 7,9	1
16	4526000	TUBE CLIP	1
17	412040R	Remote controller RC5-RC 975-630-00	1
18	4526133	Power cord cable	1
19	4523507	Step motor	1
20	453089600	Display assy. for DELTA EHK:936-034-00	1
21	453088600	PG Resin motor 12W	1
22	453089500	DELTA DCI indoor controller EHK: 916-540-00	1
23	4525998	MOTEOUR COVER	1
24	438082	Thermistor Indoor coil BLACK	1
25	4519813	Thermistor room	1
26	453027000	Terminal Cover	1

### 13.3 Indoor Unit: Delta 35 DCI

No.	Part No.	Description	Quan.
1	453036800	Grill A / DELTA 12	1
2	453100500	Grill L axis	1
3	453100600	Grill R axis	1
4	453082900	Filter for DELTA 12	2
7	465720001	Silk-screen front frame for Electra	1
8	4525987	SCREW COVER	3
9	453058201	Evap. System Assy./DELTA 35	1
10	4523526	BERAING ASSY FAN	1
11	4527111	FAN ASSY PLASTIC	1
12	452784401	IOD-12 Air Outlet Assy. (no wire)	1
13	4523693	DRAIN HOSE	1
14	4527186	IOD-12 REAR PANEL ASSY	1
15	453027500	Mount Bracket Assy./Alfa 12	1
16	4527512	Tube Clip	1
17	412040R	Remote controller RC5-RC 975-630-00	1
18	4526133	Power cord cable	1
19	4523507	Step motor	1
20	453089600	Display assy. for DELTA EHK:936-034-00	1
21	453088600	PG Resin motor 12W	1
22	453089500	DELTA DCI indoor controller EHK: 916-540-00	1
23	4525998	MOTEOR COVER	1
24	438082	Thermistor Indoor coil BLACK	1
25	4519813	Thermistor room	1
26	453027000	Terminal Cover	1

**13.4 Outdoor Unit: DCR 25 Z, DCR 35 Z R410A DCI**

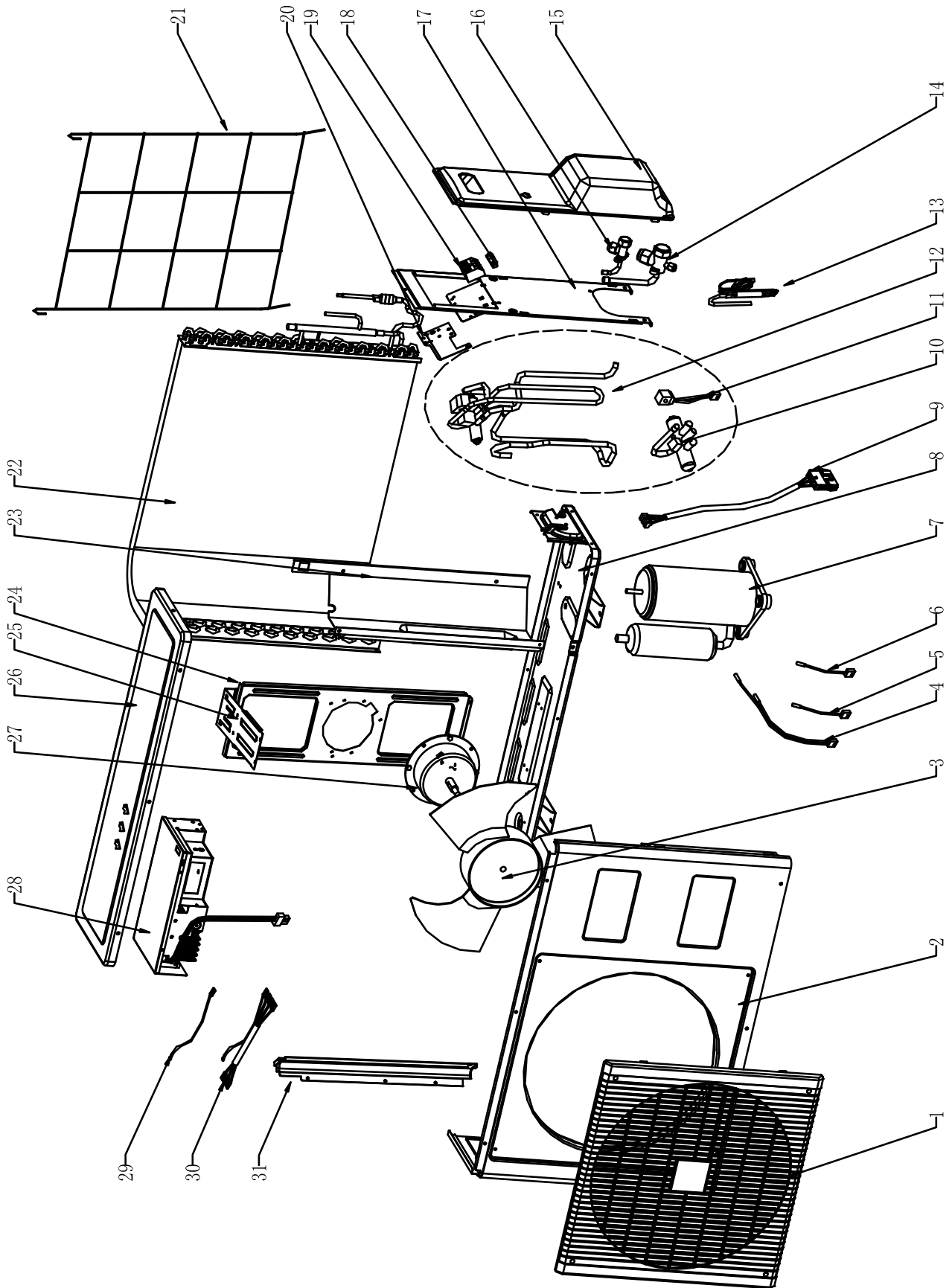

**13.5 Outdoor Unit: DCR 25 Z DCI**

No.	Part No.	Description	Quan.
1	4522551	Grille A of GCN	1
2	4523441	Front panel A Painting assy	1
3	4519251	Axial Fan OD=400	1
4	467400040	Sensor/OAT & OMT	1
5	467400200	Compressor top thermistor(CTT)	1
6	467400023	Outdoor coil thermistor(OCT)	1
7	460000032R	Compressor Assy. Toshiba DA89X1C-20FZ3	1
8	453052500	PAINTING BASE ASSY.	1
9	467000001	Compressor Power Cord	1
10	4518951	4-W valve SHF-4H for R410A	1
11	4522509	4-Way valve coil	1
12	461600067	4-way valve soldering assy FOR DCR 22/25 Z	1
13	463600050	Capillary Assy FOR DCR 22/25 Z	1
14	461010004	Gas Valve 3/8" R410A	1
15	4516857	BIG SIDE COVER	1
16	461000004	Liquid Valve 1/4" R410A	1
17	464630000	Side Plate Painting Assy.	1
18	204107	Clip set PVC	1
19	4519188	4 poles terminal block	1
20	453230000	Connect Plate	1
21	464800007	Back Guard Net Painting Assy./GCZ	1
22	462300092	Condenser Assy.FOR DCR 22/25 Z R410A	1
23	453052700	PATITION	1
24	453085600	Motor Support	1
25	453085800	Connect Plate/Motor Support	1
26	4516158	Cover panel Painting assy	1
27	453031200R	Metal motor 27W	1
28	467300225R	Controller / DCR 1.6KW OMT	1
29	452841100	Earth wire	1
30	453129300	Wire UL1007 16AWG/Controller with 250 connector	1
31	453085500	Rear Plate/Left	1

### 13.6 Outdoor Unit: DCR 35 Z DCI

No.	Part No.	Description	Quan.
1	4522551	Grille A of GCN	1
2	4523441	Front panel A Painting assy	1
3	4519251	Axial Fan OD=400	1
4	467400040	Sensor/OAT & OMT	1
5	467400200	Compressor top thermistor(CTT)	1
6	467400023	Outdoor coil thermistor(OCT)	1
7	460000033R	Compressor Assy. Toshiba DA108X1C-20FZ3	1
8	453052500	PAINTING BASE ASSY.	1
9	467000001	Compressor Power Cord	1
10	4518951	4-W valve SHF-4H for R410A	1
11	4522509	4-Way valve coil	1
12	461600068	4-way valve soldering assy FOR DCR 35 Z	1
13	463600051	Capillary Assy FOR DCR 35 Z	1
14	461010004	Gas Valve 3/8" R410A	1
15	4516857	BIG SIDE COVER	1
16	461000004	Liquid Valve 1/4" R410A	1
17	464630000	Side Plate Painting Assy.	1
18	204107	Clip set PVC	1
19	4519188	4 poles terminal block	1
20	453230000	Connect Plate	1
21	464800007	Back Guard Net Painting Assy./GCZ	1
22	462300093	Condenser Assy.FOR DCR 35 Z R410A	1
23	453052700	PATITION	1
24	453085600	Motor Support	1
25	453085800	Connect Plate/Motor Support	1
26	4516158	Cover panel Painting assy	1
27	453031200R	Metal motor 27W	1
28	467300225R	Controller / DCR 1.6KW OMT	1
29	452841100	Earth wire	1
30	453129300	Wire UL1007 16AWG/Controller with 250 connector	1
31	453085500	Rear Plate/Left	1

# APPENDIX A

## INSTALLATION AND OPERATION MANUAL

- ▶ **OPERATING MANUAL DELTA 25, 35 DCI / DCR 25Z, 35Z**
- ▶ **INSTALLATION MANUAL DELTA 25, 35 DCI / DCR 25Z, 35Z**