

Airwell

Service Manual

DC Inverter 10.0 / 12.5 / 14.0 kW

Outdoor Units	Indoor Units
GC 36 DCI	DLS 36 DCI
	DHC 36 DCI
GC 43 DCI	DLS 43 DCI
	DHC 43 DCI
GC 60 DCI	CD 60 DCI



REFRIGERANT

R410A

HEAT PUMP

SM GDCI 2-A.2 GB

NOVEMBER — 2008

LIST OF EFFECTIVE PAGES

Note: Changes in the pages are indicated by a “Revision#” in the footer of each effected page (when none indicates no changes in the relevant page). All pages in the following list represent effected/ non effected pages divided by chapters.

Dates of issue for original and changed pages are:

Original 0 February 2007

Total number of pages in this publication is 215 consisting of the following:

Page No.	Revision No. #		Page No.	Revision No. #		Page No.	Revision No. #
----------	----------------	--	----------	----------------	--	----------	----------------

Title2
 A2
 i2
 1-1 - 1-32
 2-1 - 2-52
 3-12
 4-1 - 4-32
 5-1 - 5-232
 6-1 - 6-32
 7-1 - 7-42
 8-12
 9-1 - 9-62
 10-12
 11-12
 12-1-12-262
 13-1-13-232
 14-1-14-202
 15-1-15-182
 16-1-16-62
 17-1-17-682

- Zero in this column indicates an original page.

* Due to constant improvements please note that the data on this service manual can be modified with out notice.

** Photos are not contractual.

Table of Contents

1.	INTRODUCTION	1-1
2.	PRODUCT DATA SHEET	2-1
3.	RATING CONDITIONS	3-1
4.	OUTLINE DIMENSIONS	4-1
5.	PERFORMANCE DATA & PRESSURE CURVES	5-1
6.	AIRFLOW CURVES	6-1
7.	SOUND LEVEL CHARACTERISTICS	7-1
8.	ELECTRICAL DATA	8-1
9.	WIRING DIAGRAMS	9-1
10.	REFRIGERATION DIAGRAMS	10-1
11.	TUBING CONNECTIONS	11-1
12.	CONTROL SYSTEM	12-1
13.	TROUBLESHOOTING	13-1
14.	SERVICING	14-1
15.	EXPLODED VIEWS AND SPARE PARTS LISTS	15-1
16.	OPTIONAL ACCESSORIES	16-1
17.	APPENDIX A	17-1

1. INTRODUCTION

1.1 General

The new **GC 36 / 43 / 60 DC INVERTER** ducted split unit range comprises the following RC (heat pump) models:

- **DLS 36**
- **DLS 43**
- **DHC 36**
- **DHC 43**
- **CD 60**

Remote control compatibility

The units are compatible with remote controls RC3, RC4, RCW1, RCW2, RC7.

Inverter description

Unlike standard units (fix RPM) that are selected according to their nominal capacity to overcome the maximum required load, DC Inverter units can be selected to a smaller nominal capacity range unit.

It made possible due to the ability of inverters to reach a much higher capacity level (indicated as Maximum Capacity) which is around 115-130% of the nominal capacity.

1.2 Main Features

High Technology

- Sine wave DC Compressor drive.
- DC-BL-SL (DC Brush-Less Sensor less) Inverter Compressor.
- DC-BL Inverter Outdoor Fan.
- Fuzzy Logic Adaptive Control.

System Features

- Variable cooling and heating capacity from 30% to 115% (of rated capacity).
- High COP "A-B" class energy rating (Most units).
- Low noise levels.
- Pre-charged system up to 30m.
- Tubing up to 70m length / 30m height difference.
- Networking connectivity.
- Current limitation setting for circuit breaker size reduction (if required).
- Dry contact inputs:
 - ◆ Standby.
 - ◆ Night mode (for silent operation in cooling).
 - ◆ Power Shedding (to control maximum power consumption).
- Dry contact output:
 - ◆ Alarm
 - ◆ Base Heater
 - ◆ Crank Case Heater

- HMI Display consists of 7-segments shows system diagnostics and setup.
- Monitoring software (PC port for high level service).
- Cooling operation at outdoor temperature down to -10°C.
- Heating operation at outdoor temperature down to -15°C.
- Up to 100Pa (4-5HP) and 200Pa (6HP) External static pressure.

1.3 Indoor Unit

The **DLS DCI** indoor unit is a low silhouette ducted unit, and can be easily fitted to many type of residential and commercial applications.

- Low silhouette units 300 mm height.
- High technology plastic fan and fan housing.
- Drain pool at bottom of unit with internal downward slope.
- Over-flow switch, stops compressor operation in case of a blocked drainage.
- Bended coil hydrophilic coated aluminum fins.
- 3-speed fan motor and an extra speed in case a higher external static pressure required.
- Tubing connections at the back of the unit to allow easy outlet to both sides of the unit.
- Easy installation and service access.
- Infrared remote control with liquid display unit (LCD).
- **Field options:**
 - (1) External water pump.
 - (2) Airconet connection.
 - (3) Plenum kit for connection of flexible duct hoses at air outlet.

1.4 Filtration

- The unit is equipped with pre filters.
- Easy and versatile access, rear or bottom, can be easily adjusted by the installer.

1.5 Control

The micro processor indoor controller, and an infrared remote control, supplied as standard, provides complete operating function and programming.

For further details, please refer to the Operation Manual, Appendix A.

1.6 Outdoor Unit

The **GC DCI** outdoor units can be installed as floor or wall mounted units by using a wall-supporting bracket. The metal sheets are protected by anti-corrosion paint work allowing long life resistance. All outdoor units are pre-charged. For further information, please refer to the Product Data Sheet, Chapter 2.

- Compressor mounted in a soundproofed compartment.
- Improved 3-blades axial fans for noise reduction.
- Outdoor coil with hydrophilic fins optimized for operation with R410A refrigerant.

- Fan grill air outlet.
- Service valves” flare” type connection.
- Service ports for high/ low pressure measurement.
- Interconnecting wiring terminal blocks.

1.7 Tubing Connections

Flare type-interconnecting tubing to be produced on site.
 Units can be installed with 70-meter pipe length and 30 meter height difference without oil traps.
 For further details, please refer to the Installation Manual, Chapter 17.

1.8 Accessories

No.	Item
1.	RCW Wall Mounted Remote Control
2.	RCW2 (µBMS) Wall Mounted Remote Control
3.	Base Heater
4.	Crank case Heater
5.	Room thermostat

For further details, please refer the Optional Accessories, Chapter 16.

1.9 Inbox Documentation

Each unit includes its own installation and operation manuals.

1.10 Matching Table

1.10.1 R410A

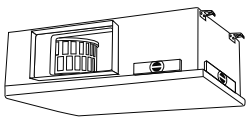
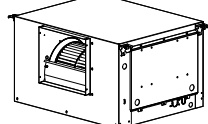
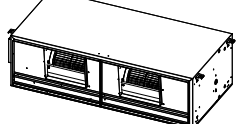
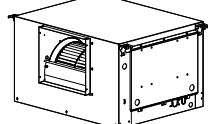
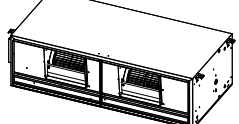
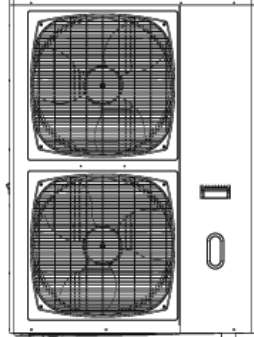
OUTDOOR UNITS	INDOOR UNITS					
						
	MODEL	DLS 36 DCI	DLS 43 DCI	DHC 36 DCI	DHC 43 DCI	CD 60 DCI
	GC 36 DCI	✓		✓		
	GC 43 DCI		✓		✓	
	GC 60 DCI					✓

2. PRODUCT DATA SHEET

2.1 DLS 36 DCI / GC 36 DCI

Model Indoor Unit			DLS 36 DCI		
Model Outdoor Unit			GC 36 DCI		
Installation Method			DUCTED		
Characteristics		Units	Cooling	Heating	
Capacity - Nominal (Minimum ~ Maximum) ⁽¹⁾		Btu/hr	34100(10900÷39200)	38200(9200 ÷ 42650)	
		kW	10.0(3.8 ÷ 11.5)	11.2(2.6 ÷ 12.5)	
Power input - Nominal (Minimum ~ Maximum) ⁽¹⁾		kW	3.125(1.400 ÷ 4.400)	3.390(1.000 ÷ 4.450)	
EER (Cooling) or COP(Heating) ⁽¹⁾		W/W	3.2	3.3	
Energy Efficiency Class			"A"	"C"	
Power supply		V/Ph/Hz	230 / 1 / 50		
Rated current (Nominal)		A	14.0	15.2	
Starting current		A	10		
Circuit breaker rating		A	25		
INDOOR	Fan type & quantity		Centrifugal x 1		
	Fan speeds	H/M/L	RPM		
	Air flow ⁽²⁾	H/M/L	m3/hr		
	External static pressure	Min-Max	Pa		
	Sound power level ⁽³⁾	H/M/L	dB(A)		
	Sound pressure level ⁽⁴⁾	H/M/L	dB(A)		
	Moisture removal (Nominal)		l/hr	3.3	
	Condensate drain tube I.D		mm	19	
	Dimensions	WxHxD	mm	854/297/816	
	Weight		kg	33	
	Package dimensions	WxHxD	mm	1010/342/917	
	Packaged weight		kg	38	
	Units per pallet		units	6	
	Stacking height		units	6	
OUTDOOR	Refrigerant control		Electronic Expansion Valve		
	Compressor type, model		Scroll		
	Motor type		DCBL Inverter		
	Fan type & quantity		Axial 2 x 493 Ømm		
	Fan speeds	H/L	RPM	900 – 100 (Continuous)	
	Airflow	Max	m3/hr	5.200	
	Sound power level ⁽³⁾	Nom C/H	dB(A)	67 / 69	
	Sound pressure level ⁽⁴⁾	Nom C/H	dB(A)	56 / 57	
	Dimensions	WxHxD	mm	900 / 1255 / 340	
	Weight		kg	110	
	Package dimensions	WxHxD	mm	985 / 1395 / 435	
	Packaged weight		kg	120	
	Units per pallet		Units	1	
	Stacking height		units	1	
	Refrigerant type			R410A	
	Refrigerant charge(standard connecting tubing length)		Kg(m)	2.9 / 30	
	Additional charge per 1 meter		g/m	38	
Connections between units	Liquid line	In.(mm)	3/8" (9.52)		
	Suction line	In.(mm)	5/8" (15.875)		
	Max.Tubing Length	m.	70		
	Max.Height Difference	m.	30		
Operation control type			LCD Remote control		
Heating elements		kW	—		
Others					

- (1) Rating conditions in accordance with ISO 5151 and ISO 13253 (for ducted units).
- (2) Airflow in ducted units; at nominal external static pressure.
- (3) Sound power in ducted units is measured at air discharge.
- (4) Sound pressure level measured at 1.0 meter distance from unit.

2.2 DLS 43 DCI / GC 43 DCI

Model Indoor Unit			DLS 43 DCI		
Model Outdoor Unit			GC 43 DCI		
Installation Method			Ducted		
Characteristics		Units	Cooling	Heating	
Capacity - Nominal (Minimum ~ Maximum) ⁽¹⁾		Btu/hr	42650(16050÷47750)	47750(15000÷54600)	
		kW	12.5 (4.7 ÷ 14.0)	14.0 (4.4 ÷ 16.0)	
Power input - Nominal (Minimum ~ Maximum) ⁽¹⁾		kW	4.170 (1.500 ÷ 5.700)	4.300 (1.100 ÷ 5.500)	
EER (Cooling) or COP(Heating) ⁽¹⁾		W/W	3.0	3.25	
Energy efficiency class			"B"	"C"	
Power supply		V/Ph/Hz	230 / 1 / 50		
Rated current (Nominal)		A	19.7	19.0	
Starting current		A	10		
Circuit breaker rating		A	32		
INDOOR	Fan type & quantity		Centrifugal x 1		
	Fan speeds	H/M/L	RPM 935 / 855 / 760		
	Air flow ⁽²⁾	H/M/L	m3/hr 2160 / 1950 / 1620		
	External static pressure	Min-Max	Pa 30-100		
	Sound power level ⁽³⁾	H/M/L	dB(A) 71 / 67 / 62		
	Sound pressure level ⁽⁴⁾	H/M/L	dB(A) 52 / 49 / 47		
	Moisture removal (Nominal)		l/hr	4.6	
	Condensate drain tube I.D		mm	19	
	Dimensions	WxHxD	mm 854 / 297 / 816		
	Weight		kg	33	
	Package dimensions	WxHxD	mm 1010 / 342 / 917		
	Packaged weight		kg	38	
	Units per pallet		units	6	
	Stacking height		units	6	
OUTDOOR	Refrigerant control		Electronic Expansion Valve		
	Compressor type, model		Scroll		
	Motor type		DCBL Inverter		
	Fan type & quantity		Axial 2 x 493 Ømm		
	Fan speeds	H/L	RPM 900 – 100 (Continuous)		
	Air flow	H/L	m3/hr 5,700		
	Sound power level ⁽³⁾	Nom C/H	dB(A) 69 / 70		
	Sound pressure level ⁽⁴⁾	Nom C/H	dB(A) 56 / 58		
	Dimensions	WxHxD	mm 900 / 1255 / 340		
	Weight		kg	110	
	Package dimensions	WxHxD	mm 985 / 1395 / 435		
	Packaged weight		kg	120	
	Units per pallet		Units	1	
	Stacking height		units	1	
	Refrigerant type		R410A		
	Refrigerant charge(standard connecting tubing length)		Kg(m)	3.1 / 30	
	Additional charge per 1 meter		g/m	38	
	Connections between units	Liquid line	In.(mm)	3/8" (9.52)	
Suction line		In.(mm)	3/4" (19.0)		
Max.Tubing Length		m.	70		
Max.Height Difference		m.	30		
Operation control type			LCD Remote control		
Heating elements		kW			
Others					

- (1) Rating conditions in accordance with ISO 5151 and ISO 13253 (for ducted units).
- (2) Airflow in ducted units; at nominal external static pressure.
- (3) Sound power in ducted units is measured at air discharge.
- (4) Sound pressure level measured at 1.0 meter distance from unit.

2.3 DHC 36 DCI / GC 36 DCI

Model Indoor Unit		DHC 36 DCI	
Model Outdoor Unit		GC 36 DCI	
Installation Method		DUCTED	
Characteristics		Units	Cooling Heating
Capacity - Nominal (Minimum ~ Maximum) ⁽¹⁾		Btu/hr	34,100 (10,250-40,950) 39,250 (12,000-42,650)
		kW	10.0 (3.0-12.0) 11.5(3.5-12.5)
Power input - Nominal (Minimum ~ Maximum) ⁽¹⁾		kW	3.05 (1.30-4.20) 3.10 (1.10-3.60)
EER (Cooling) or COP(Heating) ⁽¹⁾		W/W	3.30 3.70
Energy efficiency class			"A" "A"
Power supply		V/Ph/Hz	230 / 1 / 50
Rated current (Nominal)		A	14.0 14.2
Starting current		A	10
Circuit breaker rating		A	25
INDOOR	Fan type & quantity		Centrifugal x 1
	Fan speeds	H/M/L	RPM 1060 / 1000 / 840
	Air flow ⁽²⁾	H/M/L	m3/hr 1980 / 1820 / 1390
	External static pressure	Min-Max	Pa 20-100
	Sound power level ⁽³⁾	H/M/L	dB(A) 73 / 71 / 65
	Sound pressure level ⁽⁴⁾	H/M/L	dB(A) 52 / 50 / 45
	Moisture removal (Nominal)		l/hr 3.1
	Condensate drain tube I.D		mm 19
	Dimensions	WxHxD	mm 790X400X600
	Weight		kg 36
	Package dimensions	WxHxD	mm 825X425X610
	Packaged weight		kg 38
	Units per pallet		units 8
	Stacking height		units 4
	OUTDOOR	Refrigerant control	
Compressor type, model		Scroll	
Motor type		DCBL Inverter	
Fan type & quantity		Axial 2 x 493 Ømm	
Fan speeds		H/L	RPM 900 – 100 (Continuous)
Airflow		Max	m3/hr 5,200
Sound power level ⁽³⁾		Nom C/H	dB(A) 67 / 69
Sound pressure level ⁽⁴⁾		Nom C/H	dB(A) 56 / 57
Dimensions		WxHxD	mm 900X1255X340
Weight			kg 110
Package dimensions		WxHxD	mm 985X1395X435
Packaged weight			kg 120
Units per pallet			Units 1
Stacking height			units 1
Refrigerant type		R410A	
Refrigerant charge(standard connecting tubing length)		Kg(m) 2.9 / 30	
Additional charge per 1 meter		g/m 38	
Connections between units	Liquid line	In.(mm)	3/8" (9.52)
	Suction line	In.(mm)	5/8" (15.875)
	Max.tubing length	m.	70
	Max.height difference	m.	30
Operation control type		LCD Remote control	
Heating elements		kW —	
Others			

- (1) Rating conditions in accordance with ISO 5151 and ISO 13253 (for ducted units).
- (2) Airflow in ducted units; at nominal external static pressure.
- (3) Sound power in ducted units is measured at air discharge.
- (4) Sound pressure level measured at 1.0 meter distance from unit.

2.4 DHC 43 DCI / GC 43 DCI

Model Indoor Unit		DHC 43 DCI	
Model Outdoor Unit		GC 43 DCI	
Installation Method		DUCTED	
Characteristics		Units	Cooling Heating
Capacity - Nominal (Minimum ~ Maximum) ⁽¹⁾		Btu/hr	42,650 (11,940-47,770) 47,770 (12,280-54,590)
		kW	12.5 (3.5-14.0) 14.0 (3.6-16.0)
Power input - Nominal (Minimum ~ Maximum) ⁽¹⁾		kW	4.1 (1.65-5.5) 4.1 (1.1-5.2)
EER (Cooling) or COP(Heating) ⁽¹⁾		W/W	3.05 3.4
Energy efficiency class			B B
Power supply		V/Ph/Hz	230 / 1 / 50
Rated current		A	18.8 18.6
Starting current		A	10
Circuit breaker rating		A	32
INDOOR	Fan type & quantity		Centrifugal x 1
	Fan speeds	H/M/L	RPM 930 / 830 / 740
	Air flow ⁽²⁾	H/M/L	m3/hr 2500 / 2100 / 1600
	External static pressure	Min-Max	Pa 20-100
	Sound power level ⁽³⁾	H/M/L	dB(A) 72 / 68 / 64
	Sound pressure level ⁽⁴⁾	H/M/L	dB(A) 54 / 51 / 45
	Moisture removal (Nominal)		l/hr 3.8
	Condensate drain tube I.D		mm 19
	Dimensions	WxHxD	mm 1150X400X700
	Weight		kg 46
	Package dimensions	WxHxD	mm 1195X440X730
	Packaged weight		kg 50
	Units per pallet		units 8
	Stacking height		units 4
OUTDOOR	Refrigerant control		Electronic Expansion Valve
	Compressor type, model		Scroll
	Motor type		DCBL Inverter
	Fan type & quantity		Axial 2 x 493 Ømm
	Fan speeds	H/L	RPM 900 – 100 (Continuous)
	Air flow	Max	m3/hr 5,700
	Sound power level ⁽³⁾	Nom C/H	dB(A) 69 / 70
	Sound pressure level ⁽⁴⁾	Nom C/H	dB(A) 56 / 58
	Dimensions	WxHxD	mm 900X1255X340
	Weight		kg 110
	Package dimensions	WxHxD	mm 985X1395X435
	Packaged weight		kg 120
	Units per pallet		Units 1
	Stacking height		units 1
	Refrigerant type		R410A
	Refrigerant charge(standard connecting tubing length)		Kg(m) 3.3 / 30
	Additional charge per 1 meter		g/m 38
Connections between units	Liquid line	In.(mm)	3/8" (9.52)
	Suction line	In.(mm)	3/4" (19.0)
	Max.tubing length	m.	70
	Max.height difference	m.	30
Operation control type		LCD Remote control	
Heating elements		kW —	
Others			

- (1) Rating conditions in accordance with ISO 5151 and ISO 13253 (for ducted units).
- (2) Airflow in ducted units; at nominal external static pressure.
- (3) Sound power in ducted units is measured at air discharge.
- (4) Sound pressure level measured at 1.0 meter distance from unit.

2.5 CD 60 DCI / GC 60 DCI

Model Indoor Unit				CD 60 DCI			
Model Outdoor Unit				GC 60 DCI			
Installation Method				DUCTED			
Characteristics		Units		Cooling		Heating	
Capacity - Nominal (Minimum ~ Maximum) ⁽¹⁾		Btu/hr		47,770 (15,700 - 56,300)		54,600 (12,600 – 63,100)	
		kW		14.0 (4.6 – 16.5)		16.0 (3.7 – 18.5)	
Power Input - Nominal (Minimum ~ Maximum) ⁽¹⁾		W		4,200 (1,500 - 6,000)		4,400 (1,200 - 5,500)	
COP ⁽¹⁾		W/W		3.3		3.6	
Energy Efficiency Class		-		A		A	
Power Supply		V/Ph/Hz		220-240/1/50			
Rated Current (Nominal)		A		21.6		20.3	
Starting Current		A		<10			
Circuit Breaker Rating		A		32			
INDOOR	Fan Type & Quantity			CENTRIFUGAL x2			
	Fan Speed		H/M/L	RPM	1,160	1,120	1,000
	Airflow ⁽²⁾		H/M/L	m ³ /hr	3,300	2,900	2,000
	External Static Pressure		Min-Nom-Max	Pa	80-140-200		
	Sound Power Level ⁽³⁾		H/M/L	dB (A)	73	71	66
	Sound Pressure Level ⁽⁴⁾		H/M/L	dB (A)	58	55	50
	Moisture Removal (Nominal)		L/hr		4.0		
	Condensate Drain Tube I.D.		mm		19		
	Dimensions		W/H/D	mm	1350	400	640
	Weight		kg		75		
	Package Dimensions		W/H/D	mm	1510	440	785
	Packaged Weight		kg		82		
	Units per Pallet		Units		5		
Stacking Height		Units		5			
OUTDOOR	Refrigerant Control			Electronic Expansion Valve			
	Compressor Type, Model			Twin-Rotary			
	Motor type			DCBL Inverter			
	Fan Type & Quantity			Axial 2x 493Φmm			
	Fan Speed		RPM	900-100 (continuous)			
	Airflow		Max	m ³ /hr		5,700	
	Sound Power Level		Nom	dB (A)		68	70
	Sound Pressure Level ⁽⁴⁾		Nom	dB (A)		56	58
	Dimensions		W/H/D	mm	900	1255	340
	Weight		kg		110		
	Package Dimensions		W/H/D	mm	985	1395	435
	Packaged Weight		kg		120		
	Units per Pallet		Units		1		
	Stacking Height		Units		1		
	Refrigerant Type			R410A			
	Refrigerant Chargeless Distance		kg/m		3.8 / 30		
	Additional Charge Per 1 Meter		g/m		80		
Connections Between Units	Liquid Line		In		3/8"		
	Suction Line		In		3/4"		
	Max. Tubing Length		m		70		
	Max. Height Difference		m		30		
Operation Control Type			LCD Remote Control				
Heating Elements		kW		BH 70W - optional			
Others							

- (1) Rating conditions in accordance with ISO 5151 and ISO 13253 (for ducted units).
- (2) Airflow in ducted units; at nominal external static pressure.
- (3) Sound power in ducted units is measured at air discharge.
- (4) Sound pressure level measured at 1.0 meter distance from unit.

3. RATING CONDITIONS

Standard conditions in accordance with ISO 5151 and ISO 13253 (for ducted units) and EN 14511.

Cooling:

Indoor: 27°C DB 19°C WB

Outdoor: 35°C DB

Heating:

Indoor: 20°C DB

Outdoor: 7°C DB 6°C WB

3.1 Operating Limits

		Indoor	Outdoor
Cooling	Upper limit	32°C DB 23°C WB	46°C DB
	Lower limit	21°C DB 15°C WB	-10°C DB
Heating	Upper limit	27°C DB	24°C DB 18°C WB
	Lower limit	10°C DB	-15°C DB -16°C WB
Voltage	1PH	198 – 253V	

4. OUTLINE DIMENSIONS

4.1 Indoor Unit: DLS 36, DLS 43 DCI

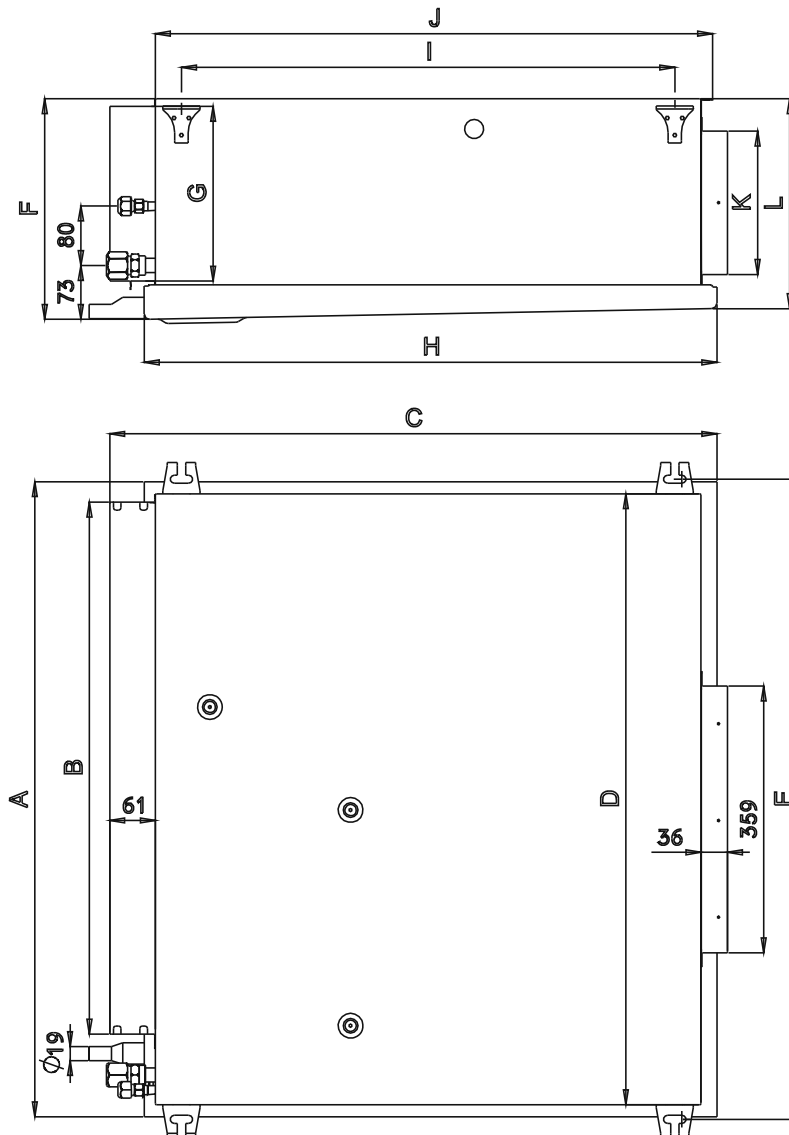

Model	A	B	C	D	E	F	G	H	I	J	K	L
DLS 36 / 43	854	715	815	822	861	297	235	770	663	749	193	282

4.2 Indoor Unit: DHC 36 DCI

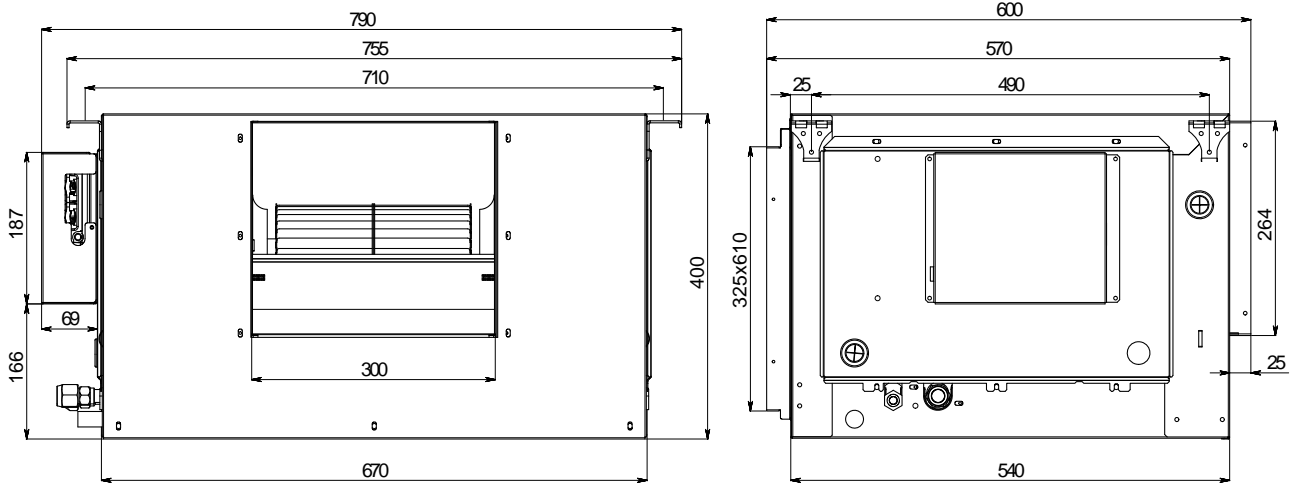

4.3 Indoor Unit: DHC 43 DCI

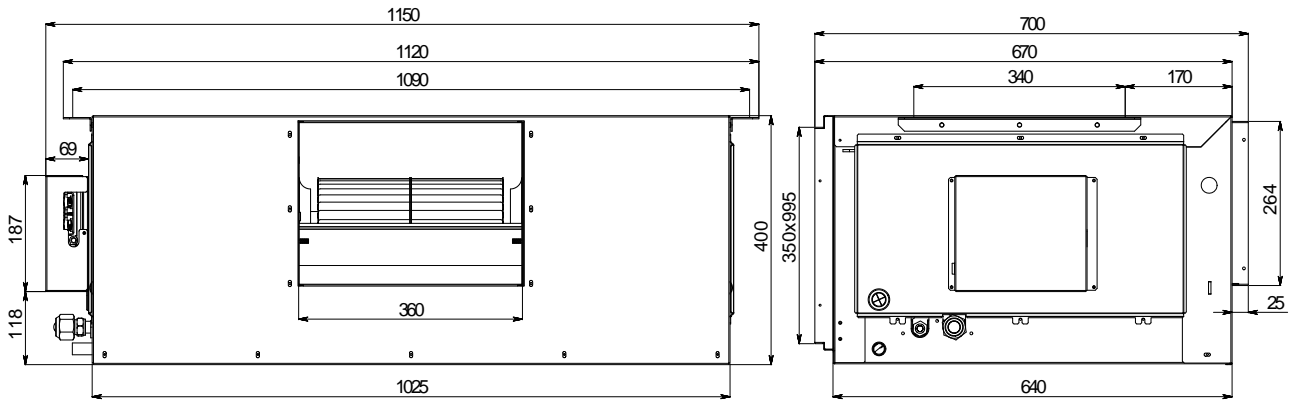

t4.4 Indoor Unit: CD 60 DCI

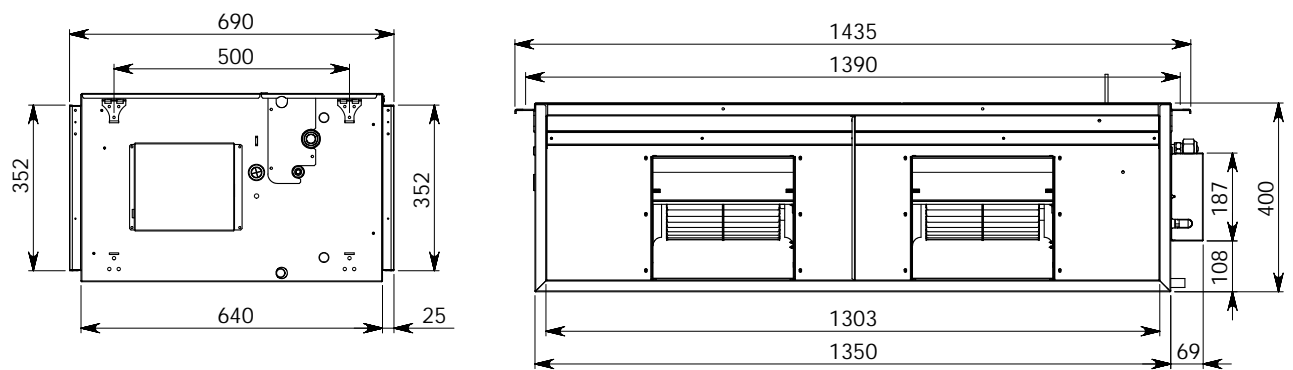

4.4 Outdoor Unit: GC 36 / 43 / 60

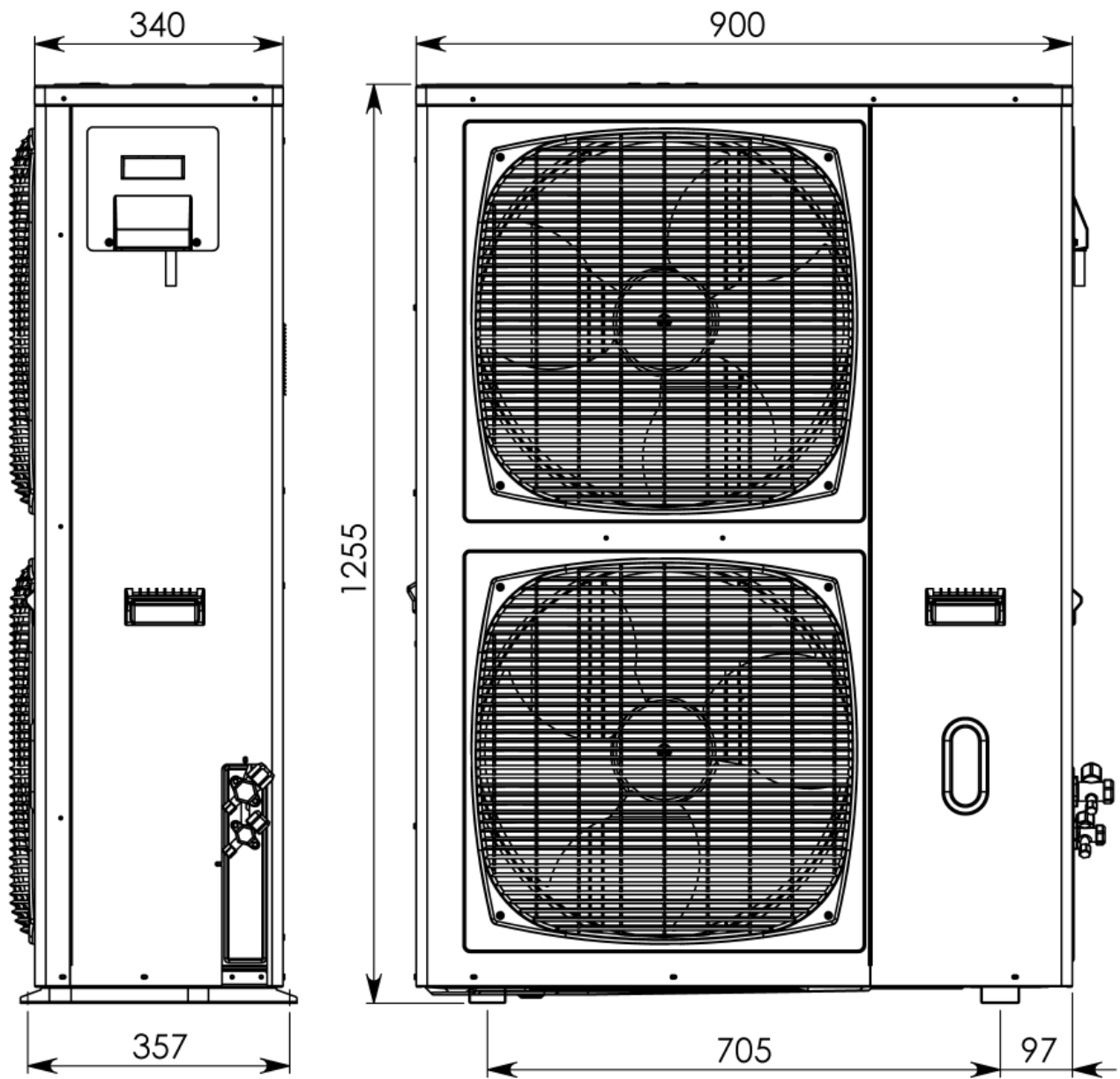

5. PERFORMANCE DATA & PRESSURE CURVES

5.1 DLS 36 DCI

5.1.1 Cooling Capacity (kW)

OD COIL ENTERING AIR DB TEMPERATURE [°C]		ID COIL ENTERING AIR DB/WB TEMPERATURE [°C]				
		22/15	24/17	27/19	29/21	32/23
-10 – 20 (protection range)	TC	80 - 110 % of nominal				
	SC	80 - 105 % of nominal				
	PI	25 - 50 % of nominal				
25	TC	9.67	10.30	10.93	11.56	12.19
	SC	7.67	7.83	7.99	8.14	8.30
	PI	2.46	2.50	2.55	2.60	2.64
30	TC	9.20	9.83	10.47	11.10	11.73
	SC	7.48	7.64	7.79	7.95	8.11
	PI	2.74	2.79	2.84	2.88	2.93
35	TC	8.74	9.37	10.00	10.63	11.26
	SC	7.29	7.44	7.60	7.76	7.91
	PI	3.03	3.08	3.13	3.17	3.22
40	TC	8.27	8.90	9.54	10.17	10.80
	SC	7.09	7.25	7.41	7.56	7.72
	PI	3.32	3.37	3.41	3.46	3.51
46	TC	7.71	8.35	8.98	9.61	10.24
	SC	6.86	7.02	7.17	7.33	7.49
	PI	3.66	3.71	3.76	3.80	3.85

LEGEND

- TC – Total Cooling Capacity, kW
- SC – Sensible Capacity, kW
- PI – Power Input, kW
- WB – Wet Bulb Temp., (°C)
- DB – Dry Bulb Temp., (°C)
- ID – Indoor
- OD – Outdoor

5.1.2 Capacity Correction Factors (Cooling)

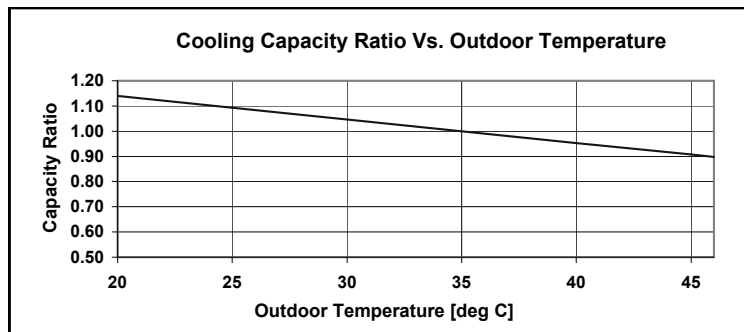

5.1.3 Heating Capacity

OD COIL ENTERING AIR DB/WB TEMPERATURE [°C]	DATA	ID COIL ENTERING AIR DB TEMPERATURE [°C]		
		15	20	25
-15/-16	TC	7.13	6.63	6.13
	PI	2.03	2.24	2.45
-10/-12	TC	7.94	7.44	6.94
	PI	2.45	2.66	2.87
-7/-8	TC	8.54	8.04	7.54
	PI	2.77	2.97	3.18
-1/-2	TC	8.84	8.34	7.85
	PI	2.92	3.13	3.34
2/1	TC	9.04	8.55	8.05
	PI	3.03	3.23	3.44
7/6	TC	11.70	11.20	10.70
	PI	3.18	3.39	3.60
10/9	TC	12.34	11.85	11.35
	PI	3.37	3.58	3.79
15/12	TC	12.99	12.49	11.99
	PI	3.56	3.77	3.98
15-24 (Protection Range)	TC	85 - 105 % of nominal		
	PI	80 - 120 % of nominal		

LEGEND

- TH – Total Heating Capacity, kW
- PI – Power Input, kW
- WB – Wet Bulb Temp., (°C)
- DB – Dry Bulb Temp., (°C)
- ID – Indoor
- OD – Outdoor

5.1.4 Capacity Correction Factors (Heating)

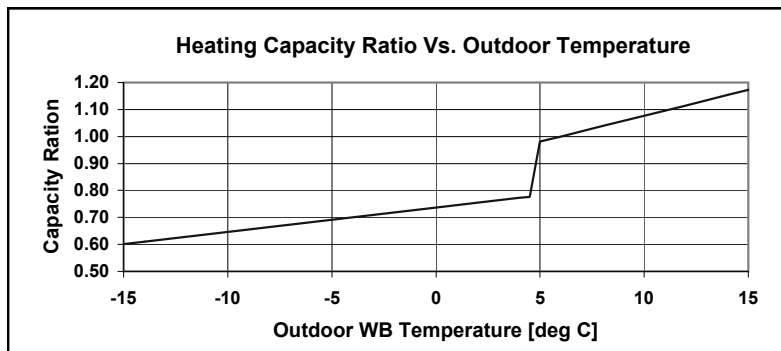

5.1.5 Pressure Curves (Cooling – Technician Mode)

5.1.5.1 Cooling

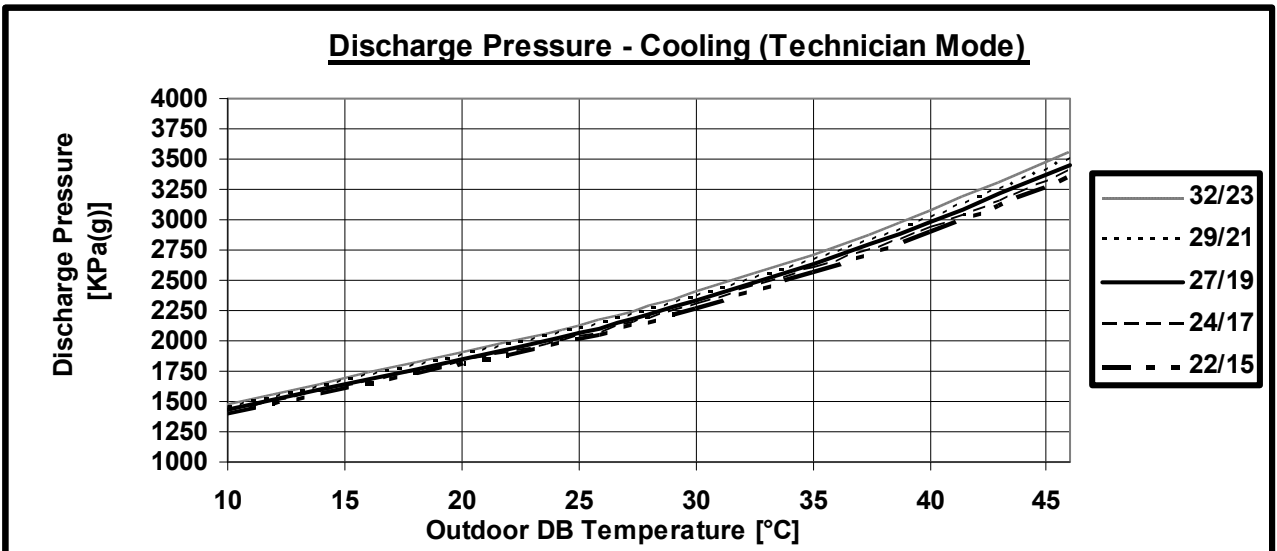
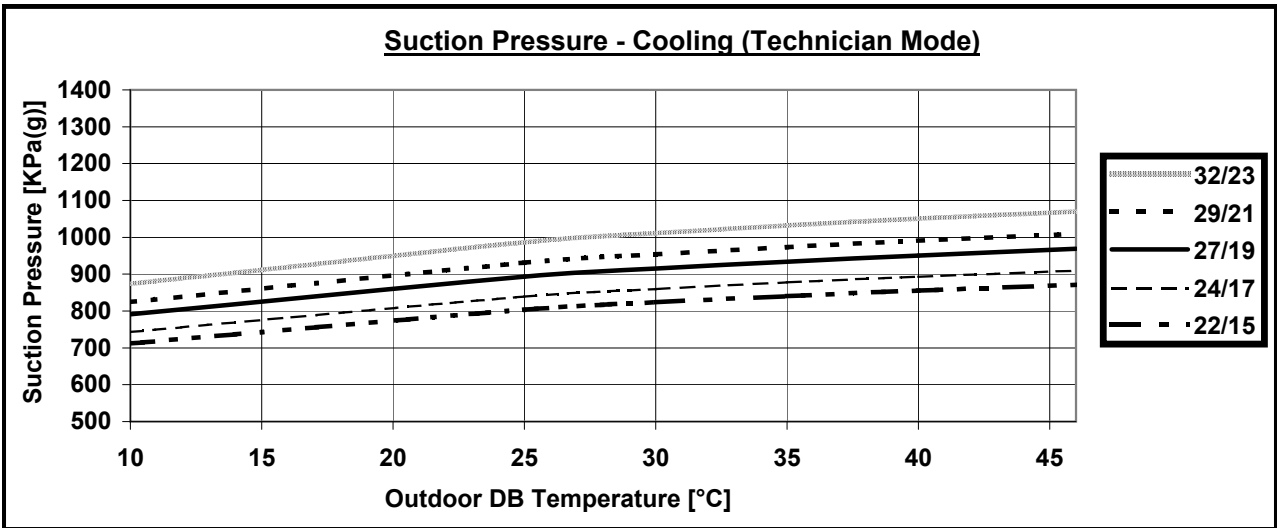

5.1.5.2 Heating

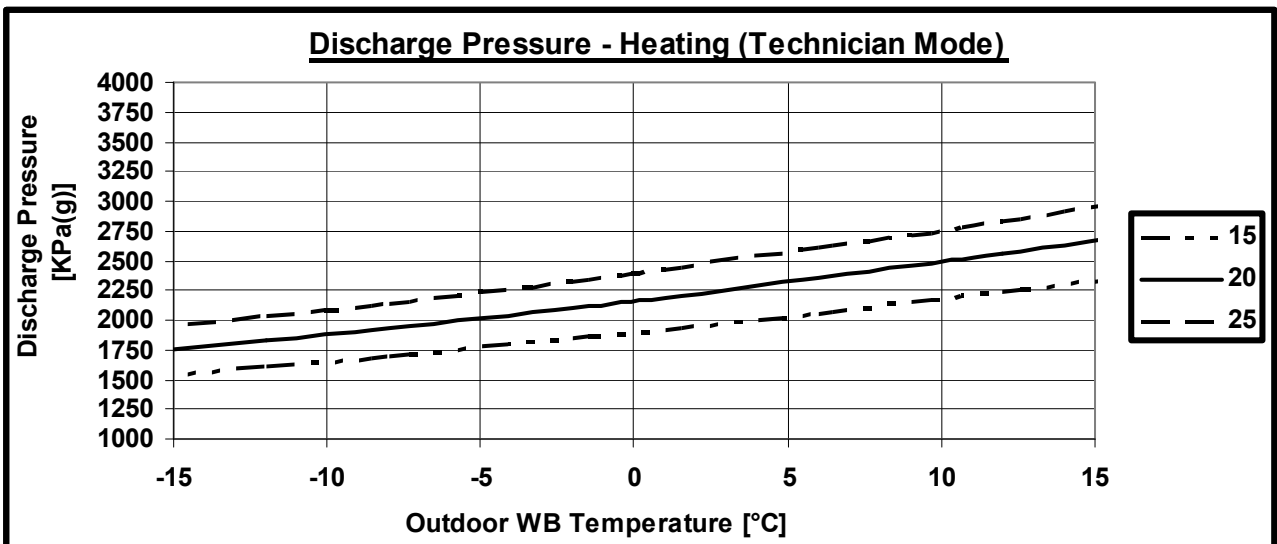
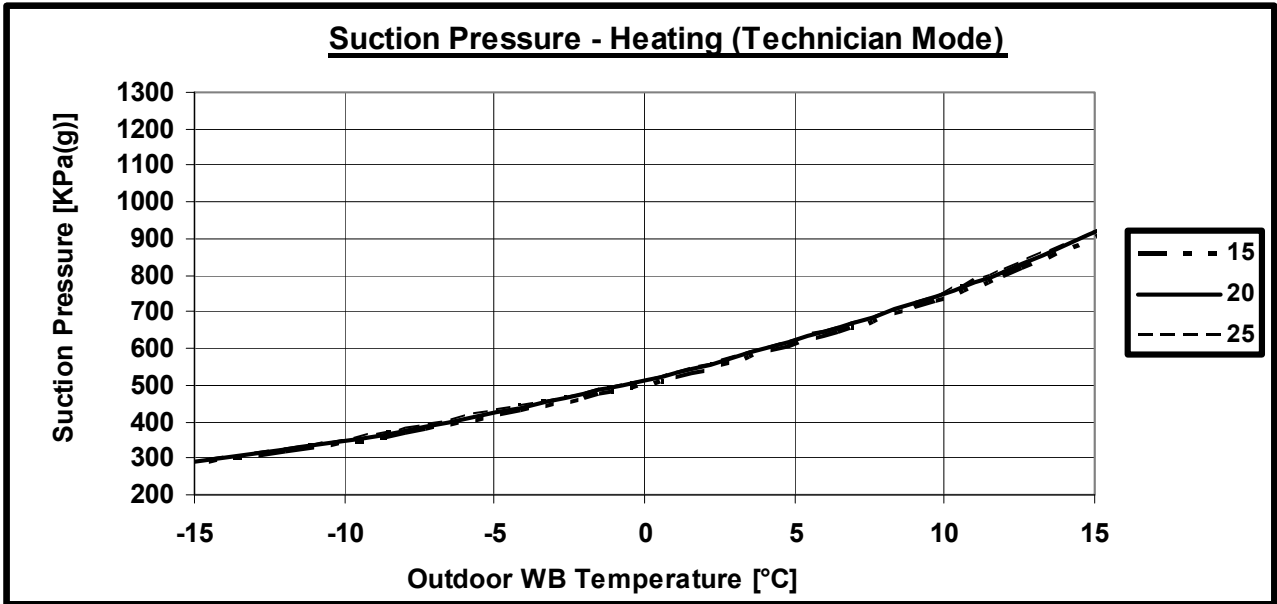

5.2 DLS 43 DCI

5.2.1 Cooling Capacity (kW)

OD COIL ENTERING AIR DB TEMPERATURE [°C]		DATA	ID COIL ENTERING AIR DB/WB TEMPERATURE [°C]				
			22/15	24/17	27/19	29/21	32/23
-10 – 20 (protection range)	TC	80 - 110 % of nominal					
	SC	80 - 105 % of nominal					
	PI	25 - 50 % of nominal					
25	TC	12.08	12.87	13.66	14.45	15.24	
	SC	9.59	9.79	9.98	10.18	10.38	
	PI	3.28	3.34	3.40	3.47	3.53	
30	TC	11.50	12.29	13.08	13.87	14.66	
	SC	9.35	9.55	9.74	9.94	10.13	
	PI	3.66	3.72	3.79	3.85	3.91	
35	TC	10.92	11.71	12.50	13.29	14.08	
	SC	9.11	9.30	9.50	9.70	9.89	
	PI	4.04	4.11	4.17	4.23	4.30	
40	TC	10.34	11.13	11.92	12.71	13.50	
	SC	8.87	9.06	9.26	9.45	9.65	
	PI	4.43	4.49	4.55	4.62	4.68	
46	TC	9.64	10.43	11.22	12.01	12.80	
	SC	8.58	8.77	8.97	9.16	9.36	
	PI	4.89	4.95	5.01	5.08	5.14	

LEGEND

- TC – Total Cooling Capacity, kW
- SC – Sensible Capacity, kW
- PI – Power Input, kW
- WB – Wet Bulb Temp., (°C)
- DB – Dry Bulb Temp., (°C)
- ID – Indoor
- OD – Outdoor

5.2.2 Capacity Correction Factors (Cooling)

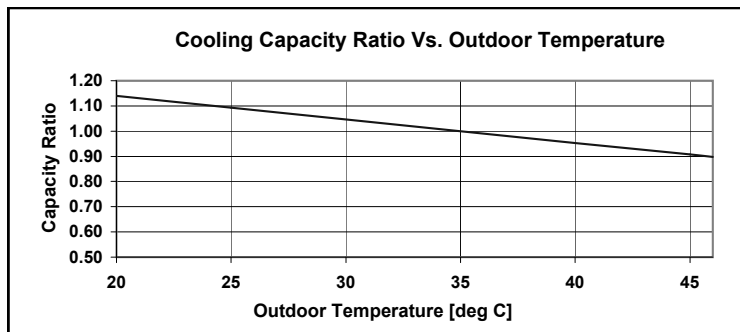

5.2.3 Heating Capacity

OD COIL ENTERING AIR DB/WB TEMPERATURE [°C]	DATA	ID COIL ENTERING AIR DB TEMPERATURE [°C]		
		15	20	25
-15/-16	TC	8.91	8.20	7.67
	PI	2.58	2.84	3.11
-10/-12	TC	9.92	9.30	8.67
	PI	3.11	3.37	3.64
-7/-8	TC	10.68	10.05	9.43
	PI	3.51	3.77	4.03
-1/-2	TC	11.05	10.43	9.81
	PI	3.71	3.97	4.23
2/1	TC	11.31	10.68	10.06
	PI	3.84	4.10	4.36
7/6	TC	14.62	14.00	13.38
	PI	4.04	4.30	4.56
10/9	TC	15.43	14.81	14.18
	PI	4.28	4.54	4.80
15/12	TC	16.24	15.61	14.99
	PI	4.52	4.78	5.04
15-24 (Protection Range)	TC	85 - 105 % of nominal		
	PI	80 - 120 % of nominal		

LEGEND

- TH – Total Heating Capacity, kW
- PI – Power Input, kW
- WB – Wet Bulb Temp., (°C)
- DB – Dry Bulb Temp., (°C)
- ID – Indoor
- OD – Outdoor

5.2.4 Capacity Correction Factors (Heating)

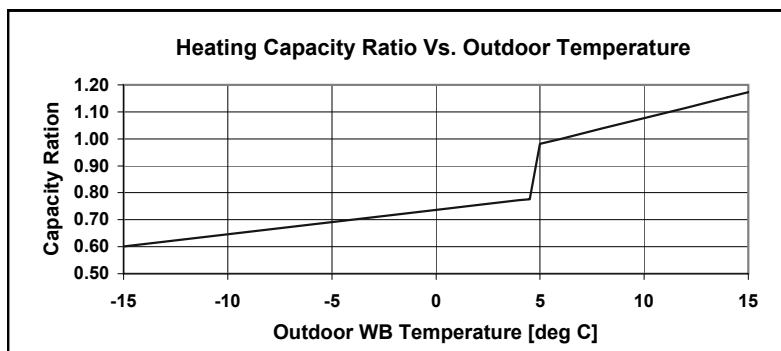

5.2.5 Pressure Curves (Cooling – Technician Mode)

5.2.5.1 Cooling

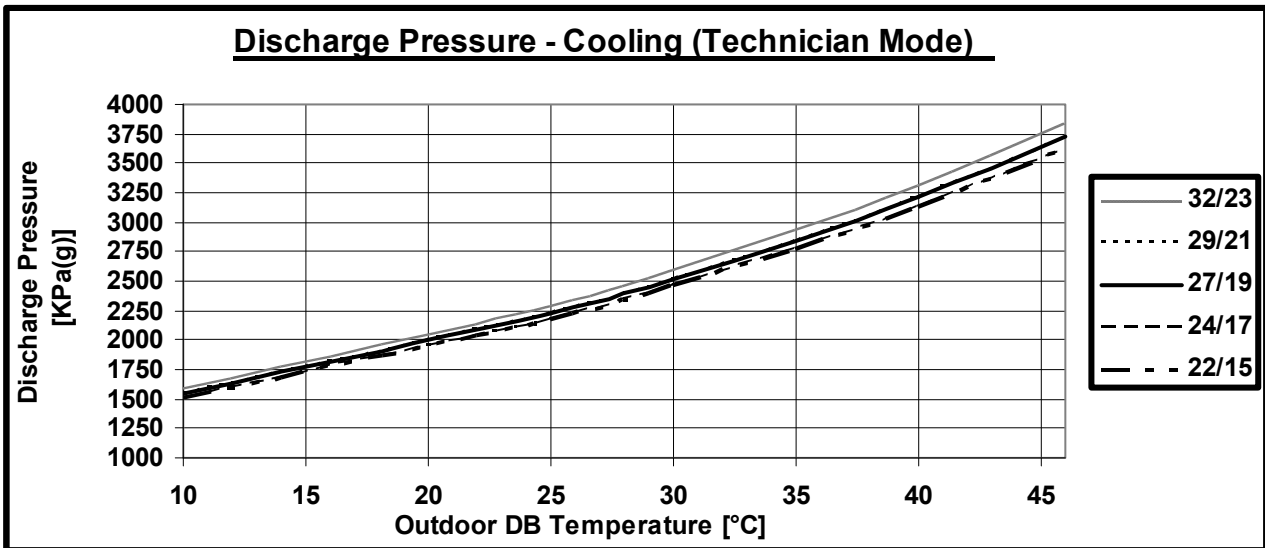
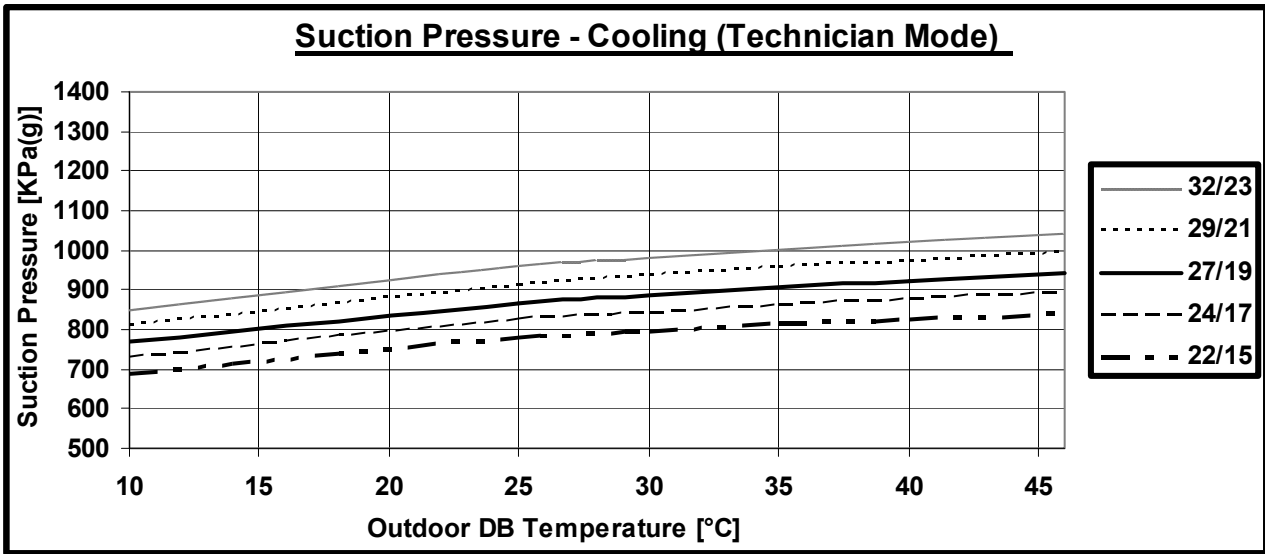

5.2.5.2 Heating

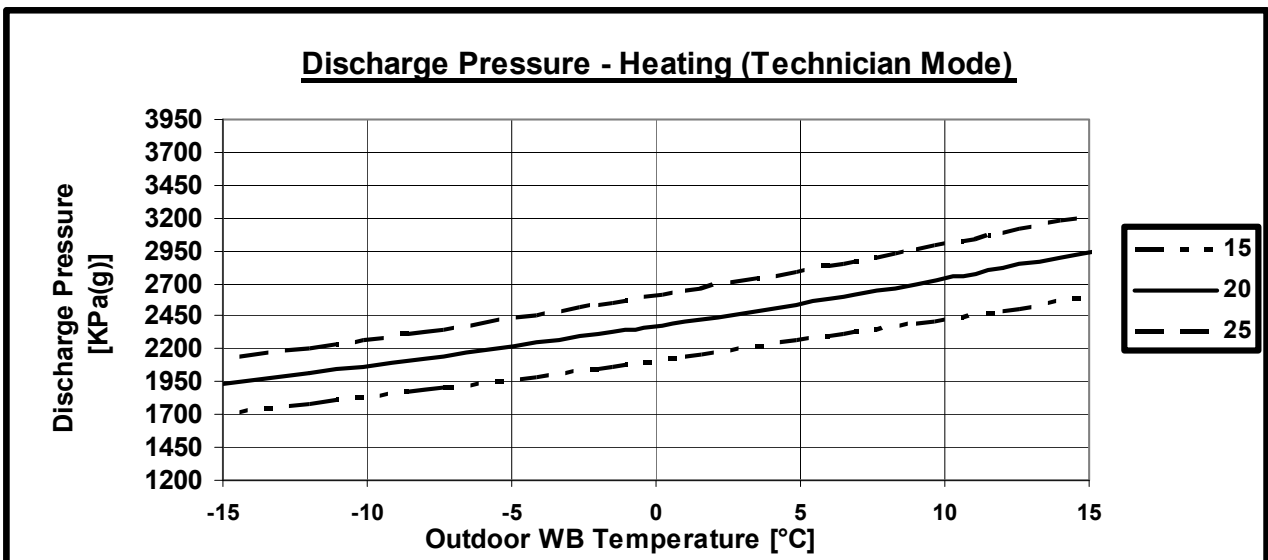
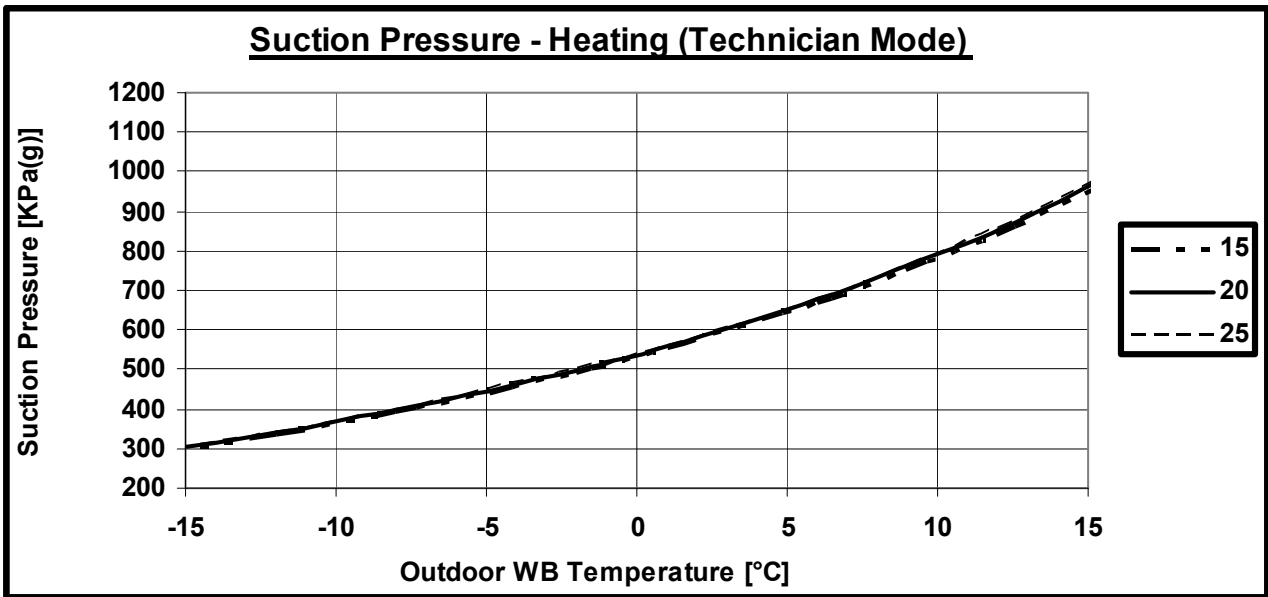

5.3 DHC 36 DCI

5.3.1 Cooling Capacity (kW)

		ID COIL ENTERING AIR DB/WB TEMPERATURE [°C]				
OD COIL ENTERING AIR DB TEMPERATURE [°C]	DATA	22/15	24/17	27/19	29/21	32/23
-10 – 20 (protection range)	TC	80 - 110 % of nominal				
	SC	80 - 105 % of nominal				
	PI	25 - 50 % of nominal				
25	TC	9.67	10.30	10.93	11.56	12.19
	SC	7.96	8.12	8.28	8.44	8.61
	PI	2.40	2.44	2.49	2.53	2.58
30	TC	9.20	9.83	10.47	11.10	11.73
	SC	7.76	7.92	8.08	8.24	8.41
	PI	2.68	2.72	2.77	2.82	2.86
35	TC	8.74	9.37	10.00	10.63	11.26
	SC	7.56	7.72	7.88	8.04	8.20
	PI	2.96	3.00	3.05	3.10	3.14
40	TC	8.27	8.90	9.54	10.17	10.80
	SC	7.35	7.52	7.68	7.84	8.00
	PI	3.24	3.28	3.33	3.38	3.42
46	TC	7.71	8.35	8.98	9.61	10.24
	SC	7.11	7.28	7.44	7.60	7.76
	PI	3.58	3.62	3.67	3.71	3.76

LEGEND

- TC – Total Cooling Capacity, kW
- SC – Sensible Capacity, kW
- PI – Power Input, kW
- WB – Wet Bulb Temp., (°C)
- DB – Dry Bulb Temp., (°C)
- ID – Indoor
- OD – Outdoor

5.3.2 Capacity Correction Factors (Cooling)

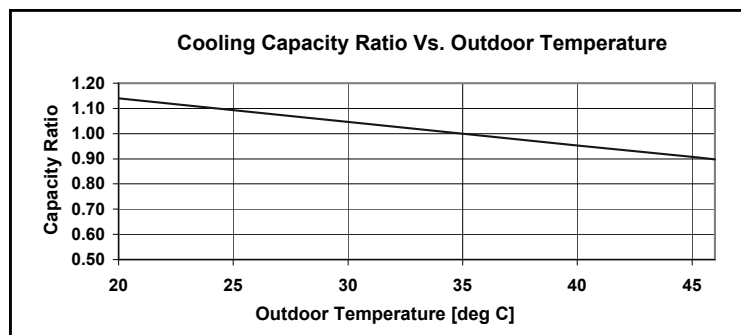

5.3.3 Heating Capacity

OD COIL ENTERING AIR DB/WB TEMPERATURE [°C]		ID COIL ENTERING AIR DB TEMPERATURE [°C]		
		15	20	25
-15/-16	TC	7.32	6.81	6.30
	PI	1.86	2.05	2.24
-10/-12	TC	8.15	7.64	7.12
	PI	2.24	2.43	2.62
-7/-8	TC	8.77	8.26	7.75
	PI	2.53	2.72	2.91
-1/-2	TC	9.08	8.57	8.06
	PI	2.67	2.86	3.05
2/1	TC	9.29	8.77	8.26
	PI	2.77	2.96	3.15
7/6	TC	12.01	11.50	10.99
	PI	2.91	3.10	3.29
10/9	TC	12.67	12.16	11.65
	PI	3.08	3.27	3.46
15/12	TC	13.34	12.82	12.31
	PI	3.26	3.45	3.64
15-24 (Protection Range)	TC	85 - 105 % of nominal		
	PI	80 - 120 % of nominal		

LEGEND

- TH – Total Heating Capacity, kW
- PI – Power Input, kW
- WB – Wet Bulb Temp., (°C)
- DB – Dry Bulb Temp., (°C)
- ID – Indoor
- OD – Outdoor

5.3.4 Capacity Correction Factors (Heating)

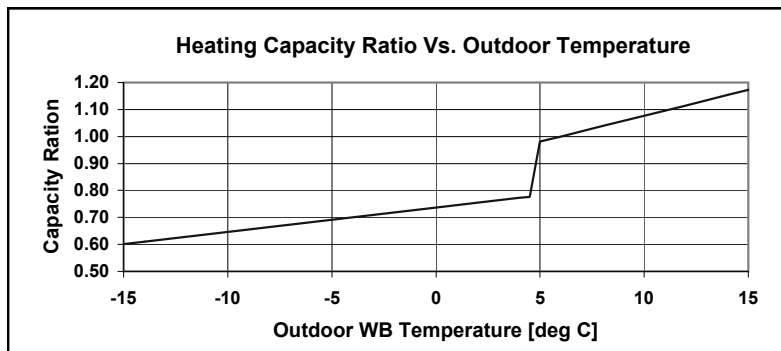

5.3.5 Pressure Curves (Cooling – Technician Mode)

5.3.5.1 Cooling

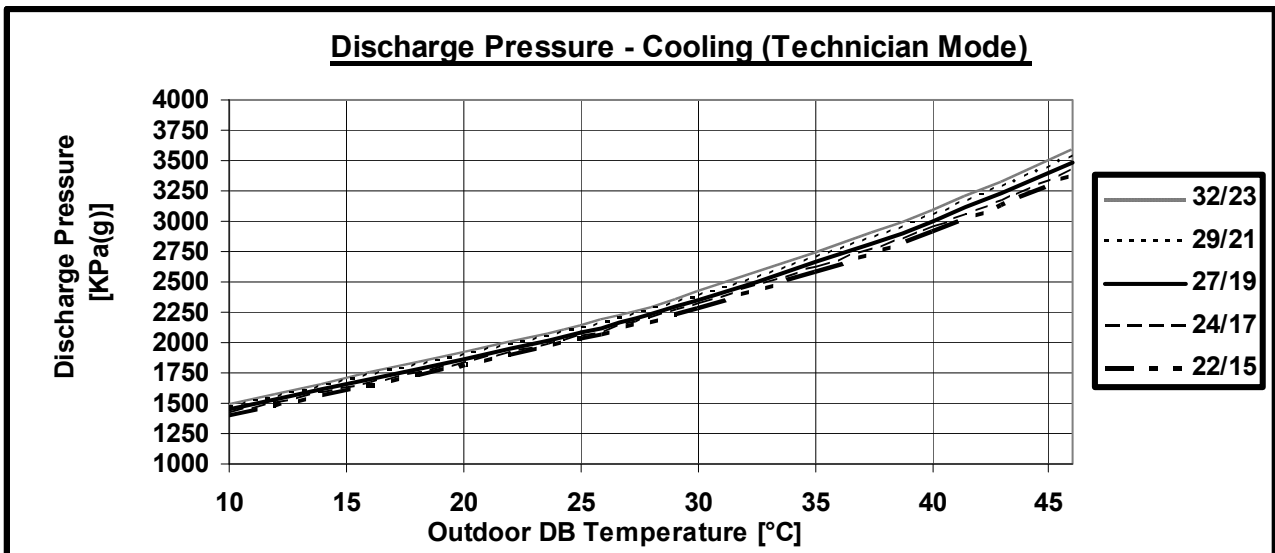
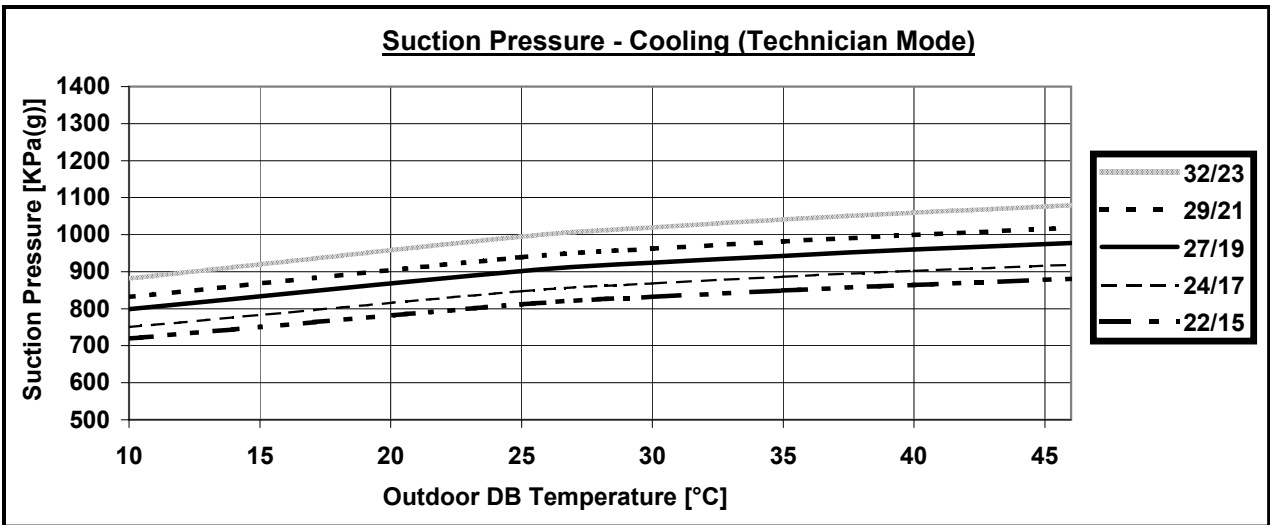

5.3.5.2 Heating

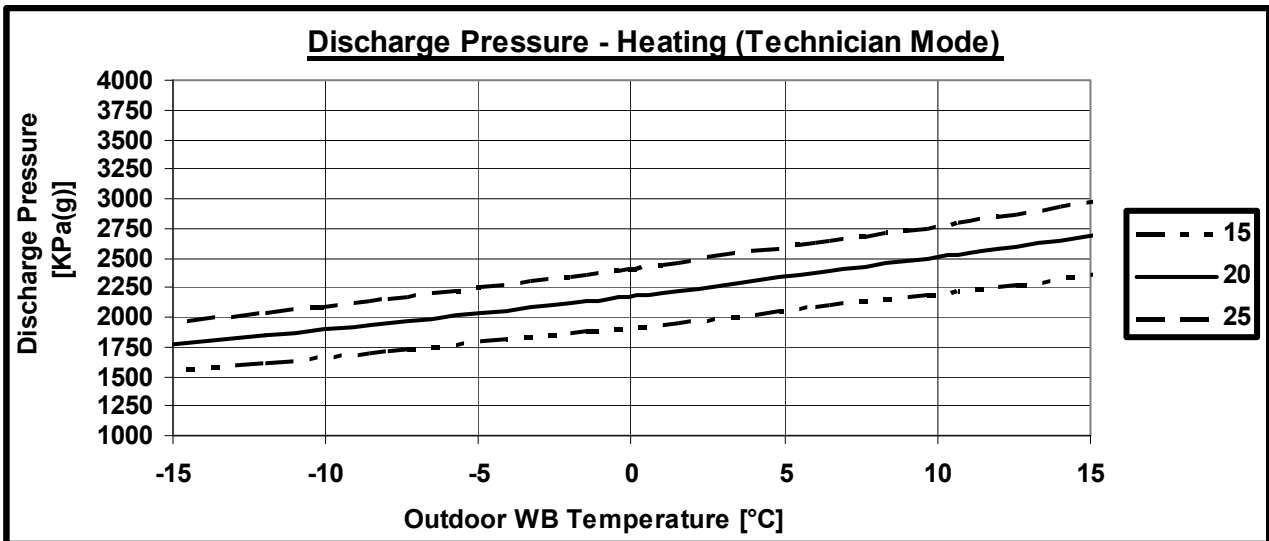
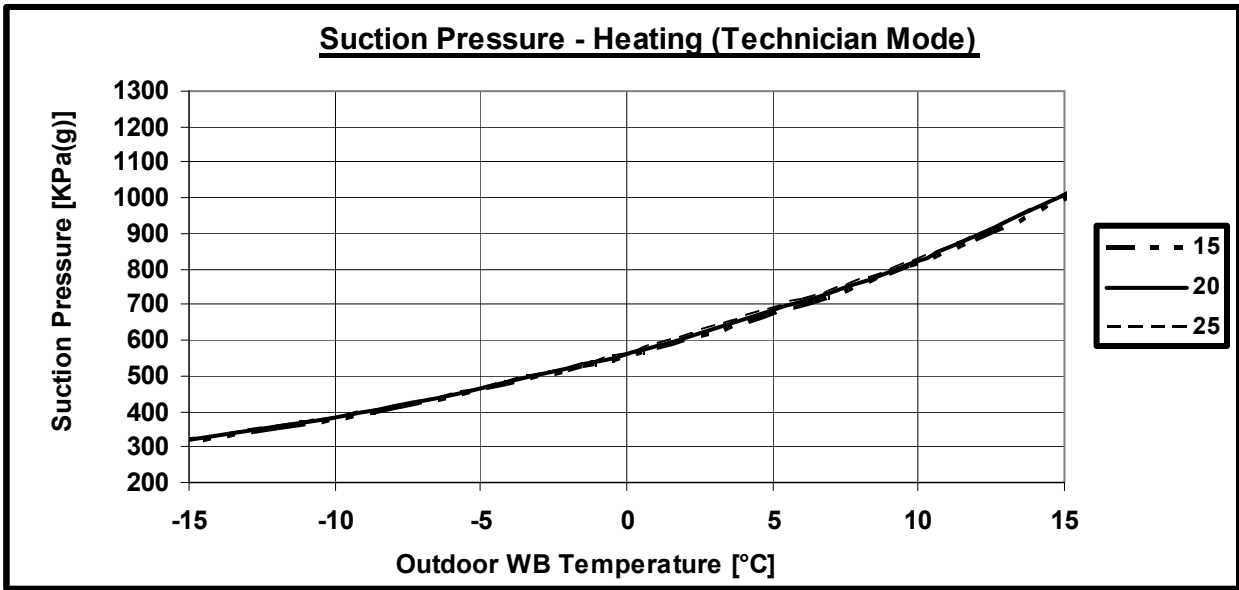

5.4 DHC 43 DCI

5.4.1 Cooling Capacity (kW)

OD COIL ENTERING AIR DB TEMPERATURE [°C]		DATA	ID COIL ENTERING AIR DB/WB TEMPERATURE [°C]				
			22/15	24/17	27/19	29/21	32/23
-10 – 20 (protection range)	TC	80 - 110 % of nominal					
	SC	80 - 105 % of nominal					
	PI	25 - 50 % of nominal					
25	TC	12.08	12.87	13.66	14.45	15.24	
	SC	9.87	10.07	10.27	10.47	10.68	
	PI	3.22	3.28	3.35	3.41	3.47	
30	TC	11.50	12.29	13.08	13.87	14.66	
	SC	9.62	9.82	10.02	10.23	10.43	
	PI	3.60	3.66	3.72	3.78	3.85	
35	TC	10.92	11.71	12.50	13.29	14.08	
	SC	9.37	9.57	9.78	9.98	10.18	
	PI	3.98	4.04	4.10	4.16	4.22	
40	TC	10.34	11.13	11.92	12.71	13.50	
	SC	9.12	9.32	9.53	9.73	9.93	
	PI	4.35	4.42	4.48	4.54	4.60	
46	TC	9.64	10.43	11.22	12.01	12.80	
	SC	8.82	9.03	9.23	9.43	9.63	
	PI	4.71	4.87	4.93	4.99	5.05	

LEGEND

- TC – Total Cooling Capacity, kW
- SC – Sensible Capacity, kW
- PI – Power Input, kW
- WB – Wet Bulb Temp., (°C)
- DB – Dry Bulb Temp., (°C)
- ID – Indoor
- OD – Outdoor

5.4.2 Capacity Correction Factors (Cooling)

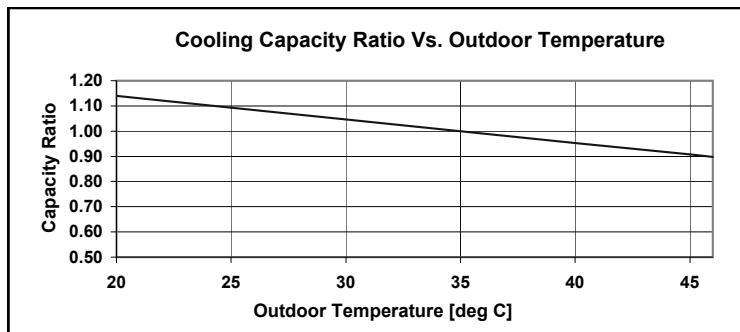

5.4.3 Heating Capacity

OD COIL ENTERING AIR DB/WB TEMPERATURE [°C]	DATA	ID COIL ENTERING AIR DB TEMPERATURE [°C]		
		15	20	25
-15/-16	TC	8.91	8.29	7.67
	PI	2.47	2.72	2.97
-10/-12	TC	9.92	9.30	8.67
	PI	2.97	3.22	3.47
-7/-8	TC	10.68	10.05	9.43
	PI	3.35	3.60	3.85
-1/-2	TC	11.05	10.43	9.81
	PI	3.54	3.79	4.04
2/1	TC	11.31	10.68	10.06
	PI	3.67	3.92	4.17
7/6	TC	14.62	14.00	13.38
	PI	3.86	4.11	4.36
10/9	TC	15.43	14.81	14.18
	PI	4.09	4.34	4.59
15/12	TC	16.24	15.61	14.99
	PI	4.32	4.57	4.82
15-24 (Protection Range)	TC	85 - 105 % of nominal		
	PI	80 - 120 % of nominal		

LEGEND

- TH – Total Heating Capacity, kW
- PI – Power Input, kW
- WB – Wet Bulb Temp., (°C)
- DB – Dry Bulb Temp., (°C)
- ID – Indoor
- OD – Outdoor

5.4.4 Capacity Correction Factors (Heating)

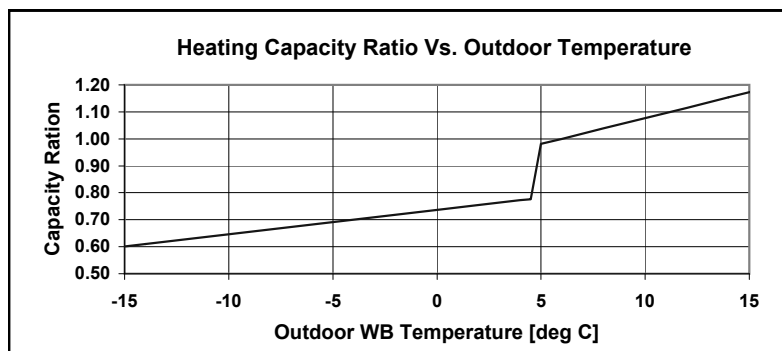

5.4.5 Pressure Curves (Cooling – Technician Mode)

5.4.5.1 Cooling

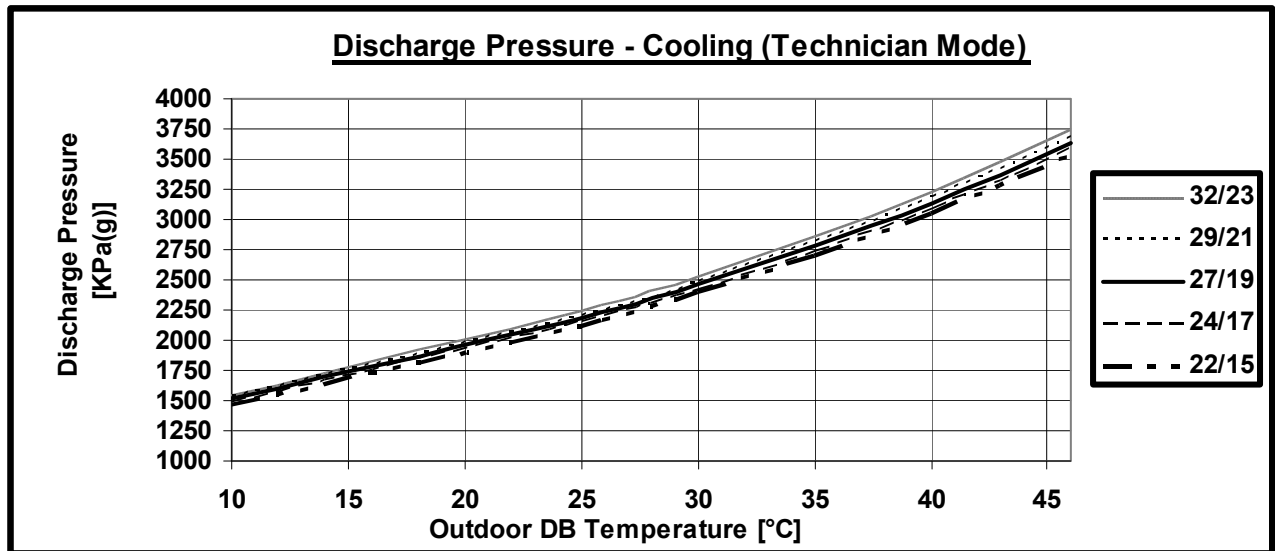
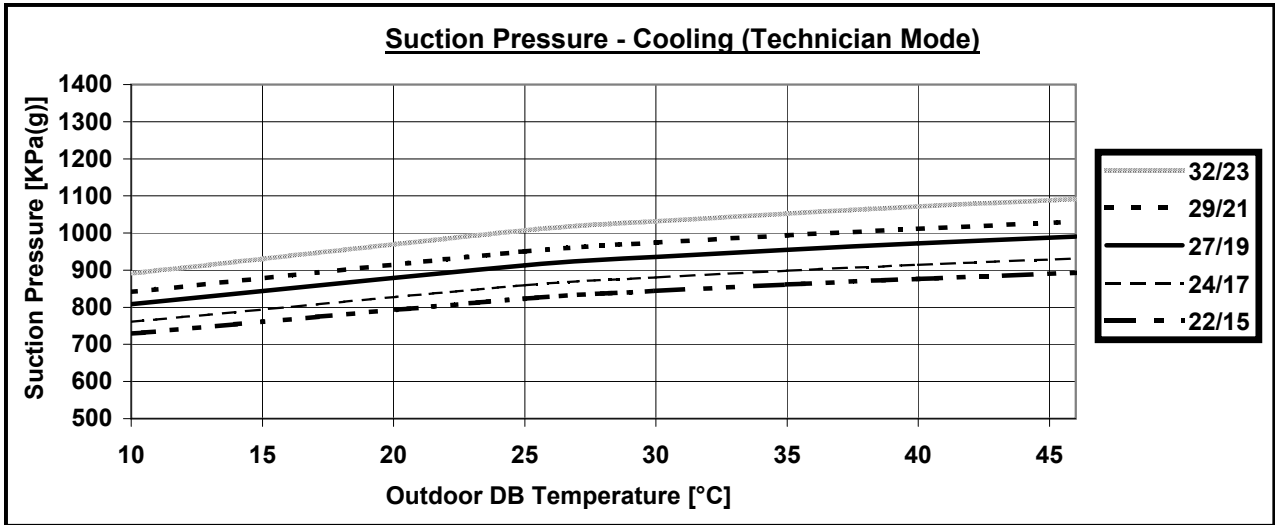

5.4.5.2 Heating

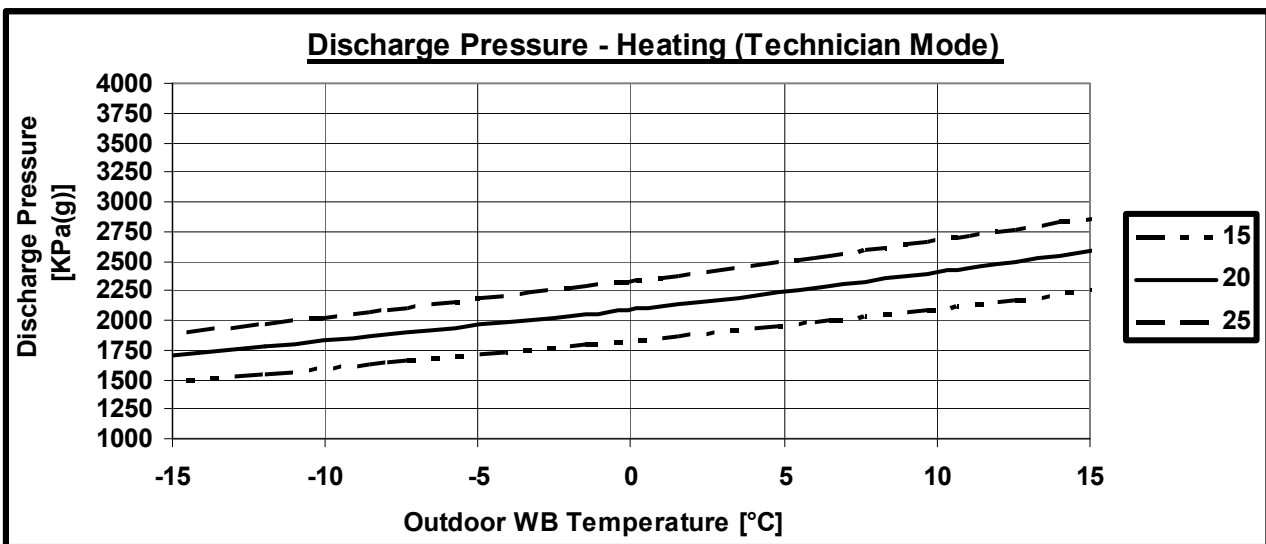
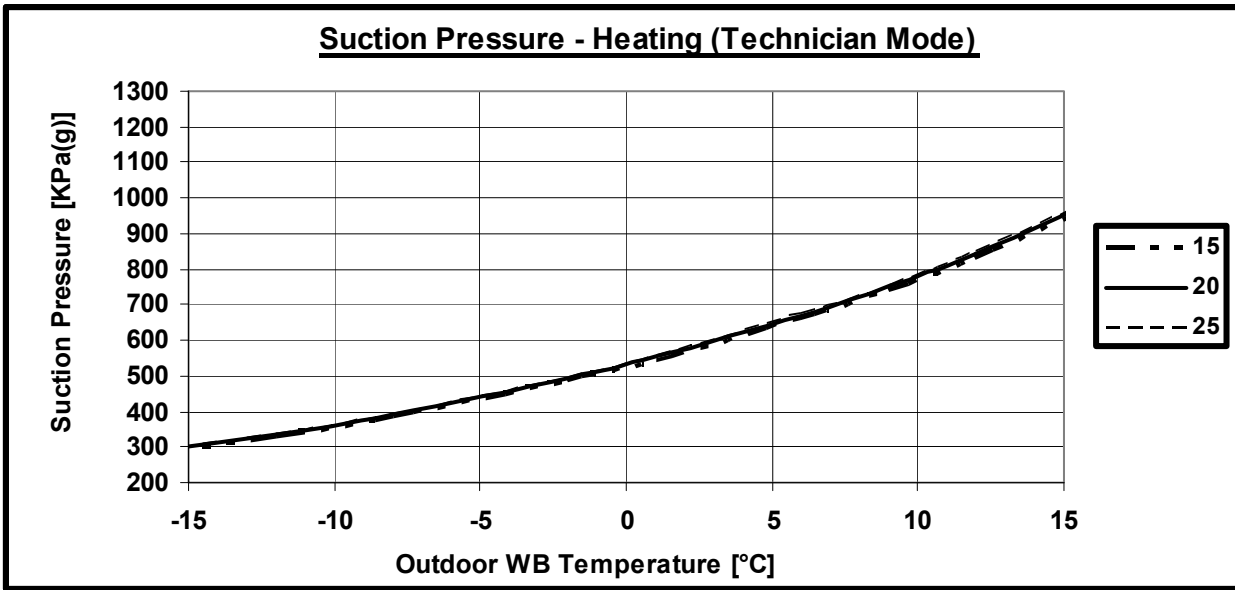

5.5 CD 60 DCI

5.5.1 Cooling Capacity (kW)

OD COIL ENTERING AIR DB TEMPERATURE [°C]		DATA	ID COIL ENTERING AIR DB/WB TEMPERATURE [°C]				
			22/15	24/17	27/19	29/21	32/23
-10 - 20 (protection range)	TC	80 - 110 % of nominal					
	SC	80 - 105 % of nominal					
	PI	25 - 50 % of nominal					
25	TC	13.53	14.42	15.30	16.19	17.07	
	SC	11.31	11.54	11.77	12.00	12.23	
	PI	3.30	3.36	3.43	3.49	3.55	
30	TC	12.88	13.77	14.65	15.54	16.42	
	SC	11.02	11.25	11.49	11.72	11.95	
	PI	3.69	3.75	3.81	3.88	3.94	
35	TC	12.23	13.12	14.00	14.88	15.77	
	SC	10.74	10.97	11.20	11.43	11.66	
	PI	4.07	4.14	4.20	4.26	4.33	
40	TC	11.58	12.46	13.35	14.23	15.12	
	SC	10.45	10.68	10.91	11.15	11.38	
	PI	4.46	4.52	4.59	4.65	4.71	
46	TC	10.80	11.68	12.57	13.45	14.34	
	SC	10.11	10.34	10.57	10.80	11.03	
	PI	4.92	4.99	5.05	5.11	5.18	

LEGEND

- TC – Total Cooling Capacity, kW
- SC – Sensible Capacity, kW
- PI – Power Input, kW
- WB – Wet Bulb Temp., (°C)
- DB – Dry Bulb Temp., (°C)
- ID – Indoor
- OD – Outdoor

5.5.2 Capacity Correction Factors (Cooling)

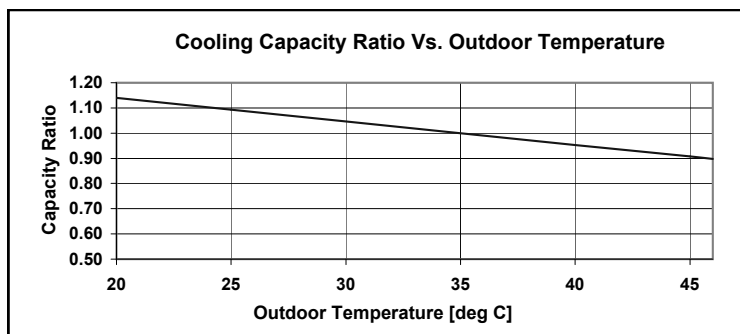

5.5.3 Heating Capacity

OD COIL ENTERING AIR DB/WB TEMPERATURE [°C]	DATA	ID COIL ENTERING AIR DB TEMPERATURE [°C]		
		15	20	25
-15/-16	TC	10.18	9.47	8.76
	PI	2.64	2.91	3.18
-10/-12	TC	11.34	10.62	9.91
	PI	3.18	3.45	3.72
-7/-8	TC	12.20	11.49	10.78
	PI	3.59	3.86	4.13
-1/-2	TC	12.63	11.92	11.21
	PI	3.79	4.06	4.33
2/1	TC	12.92	12.21	11.50
	PI	3.93	4.20	4.47
7/6	TC	16.71	16.00	15.29
	PI	4.13	4.40	4.67
10/9	TC	17.63	16.92	16.21
	PI	4.38	4.65	4.92
15/12	TC	18.56	17.84	17.13
	PI	4.63	4.89	5.16
15-24 (Protection Range)	TC	85 - 105 % of nominal		
	PI	80 - 120 % of nominal		

LEGEND

- TH – Total Heating Capacity, kW
- PI – Power Input, kW
- WB – Wet Bulb Temp., (°C)
- DB – Dry Bulb Temp., (°C)
- ID – Indoor
- OD – Outdoor

5.5.4 Capacity Correction Factors (Heating)

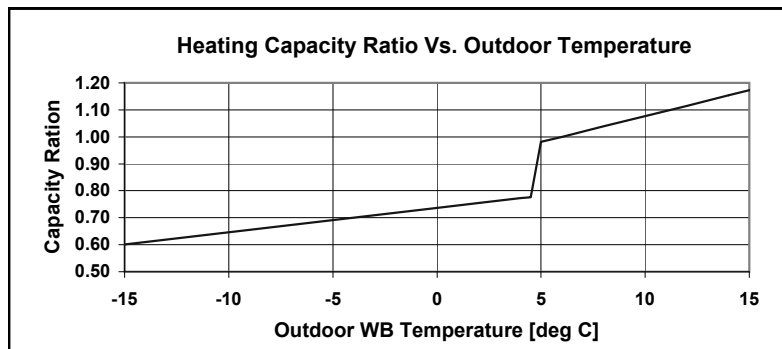

5.5.5 Pressure Curves (Cooling – Technician Mode)

5.5.5.1 Cooling

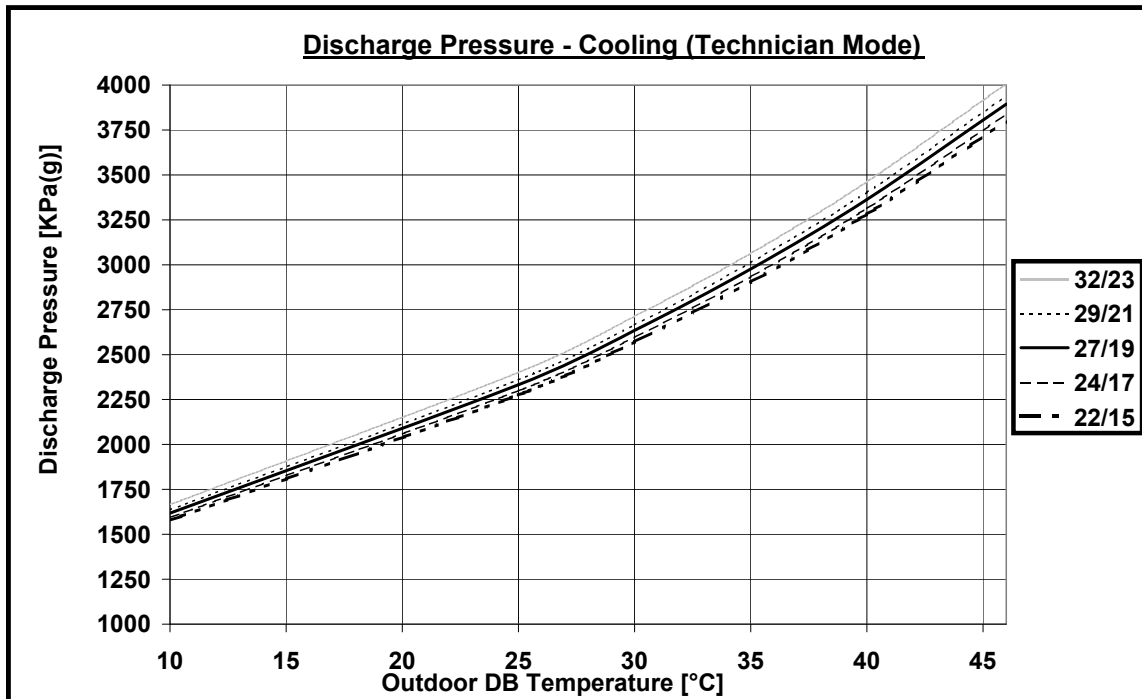
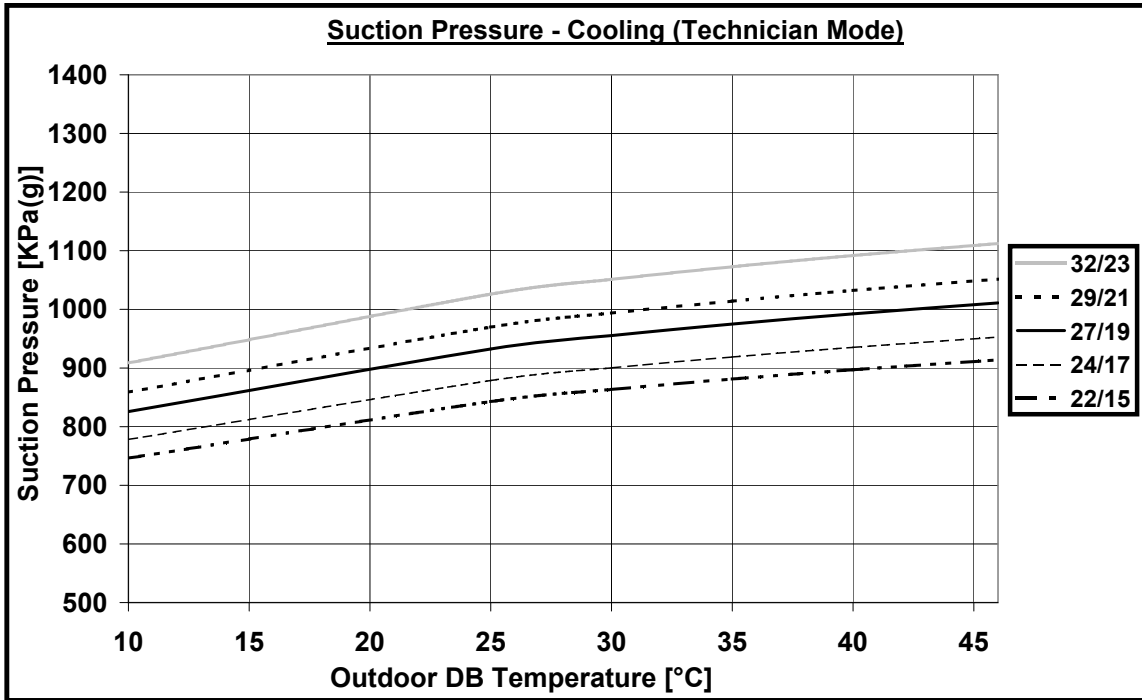

5.5.5.2 Heating

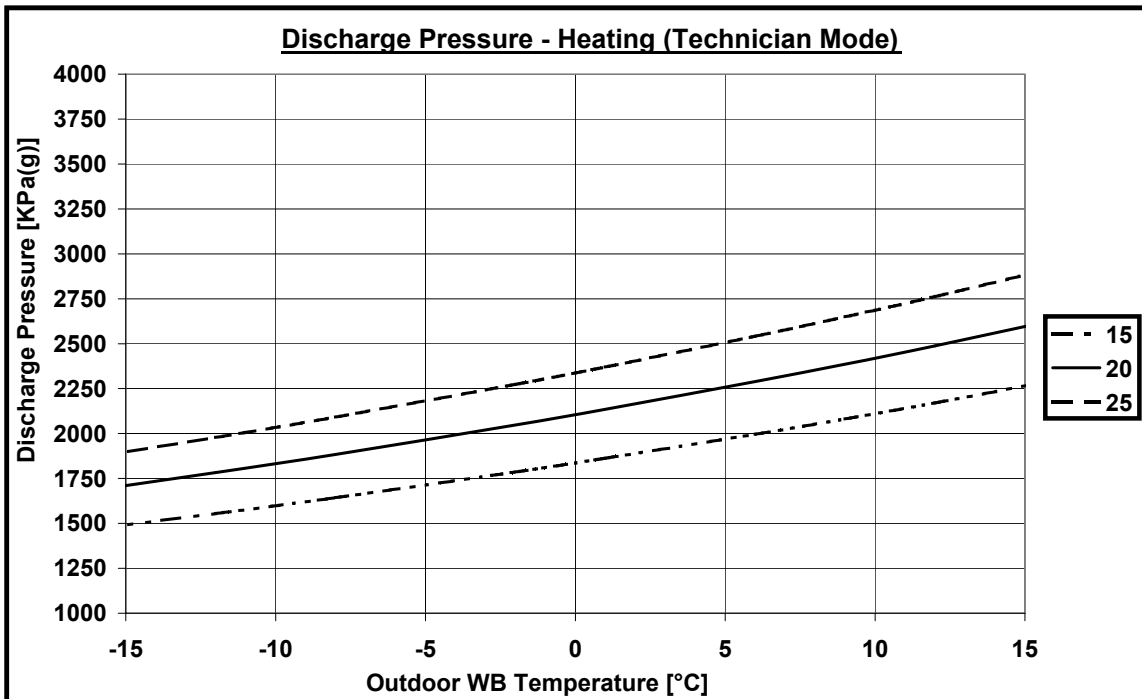
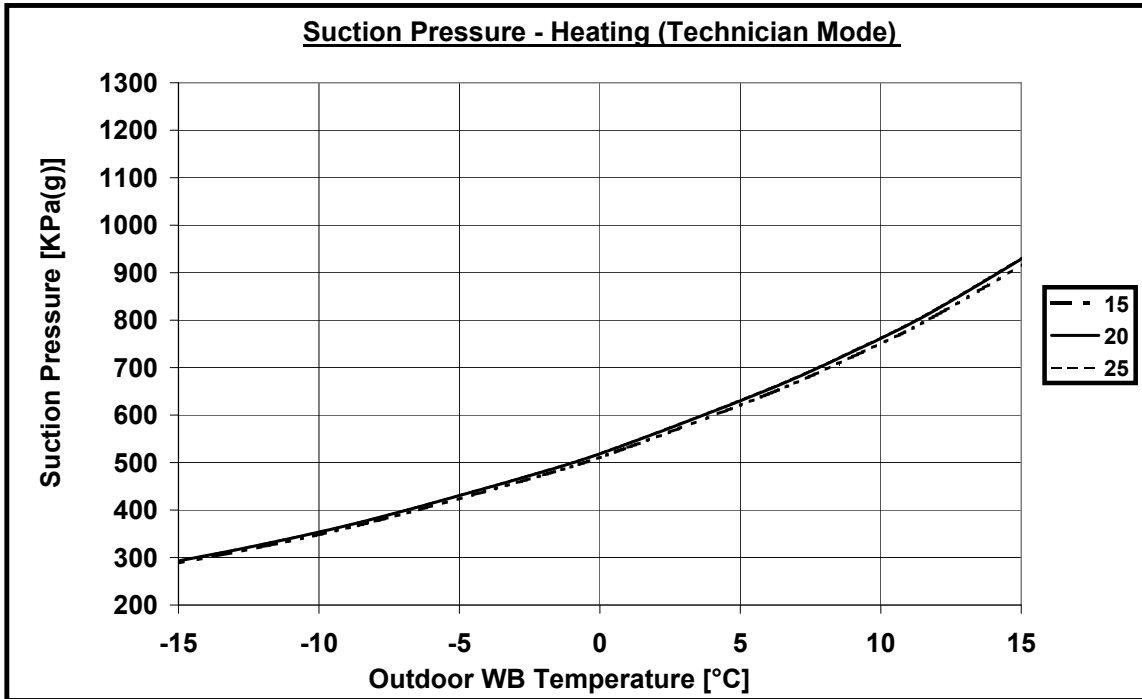

5.6 Capacity Correction Factor for Tubing Length

5.6.1 Cooling

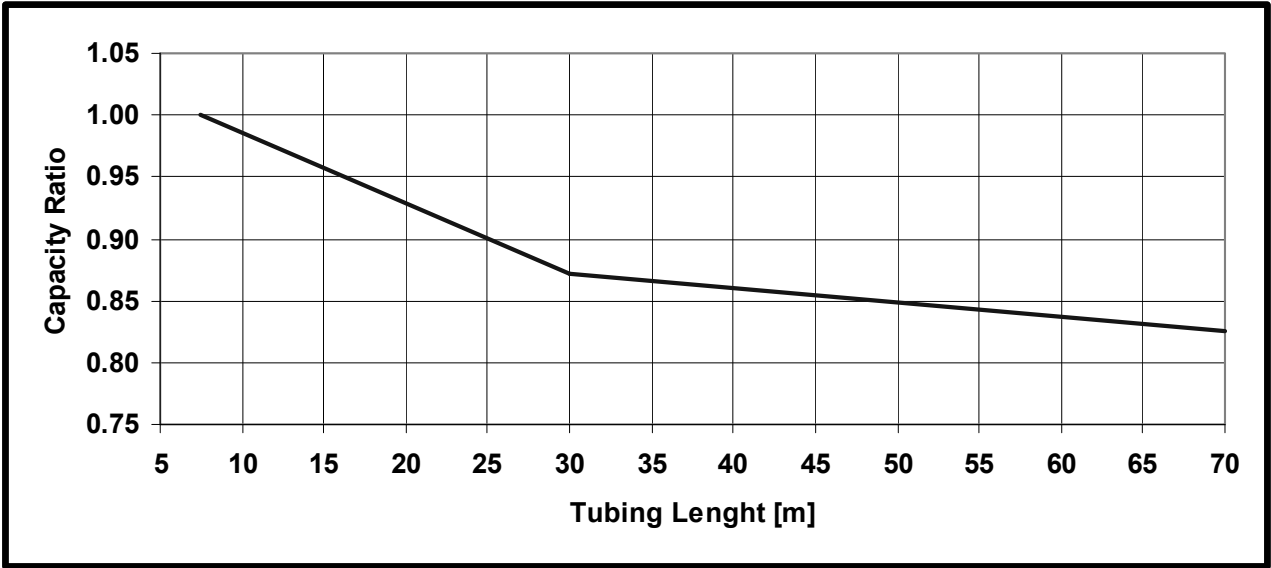

5.6.2 Heating

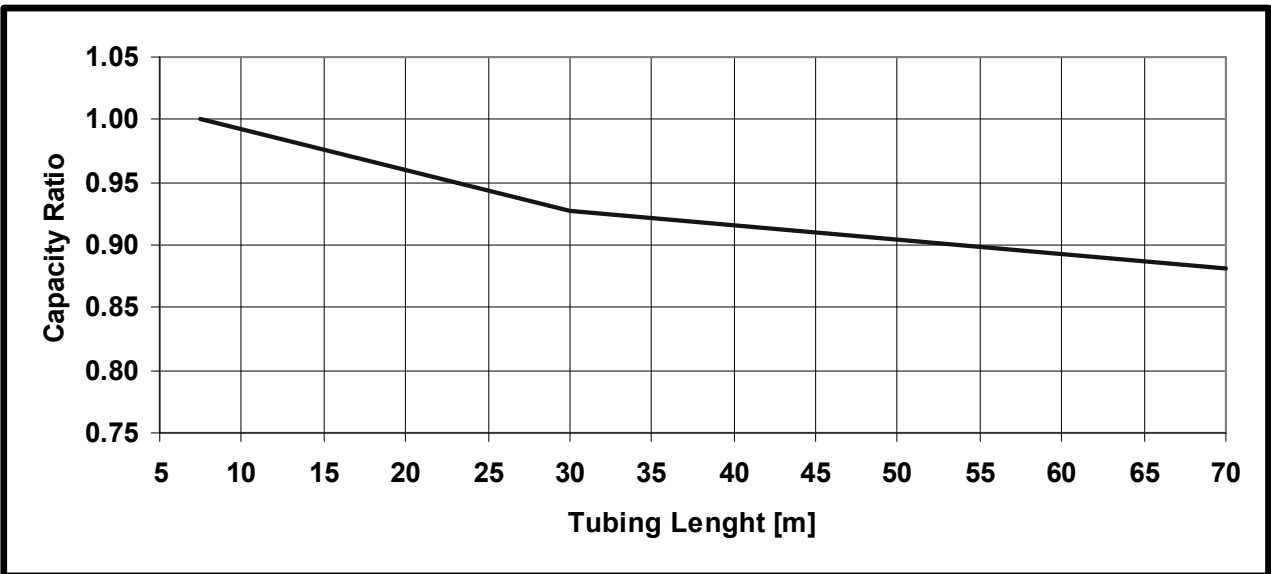

5.7 Pressure Correction Factor for Tubing Length

5.7.1 Cooling

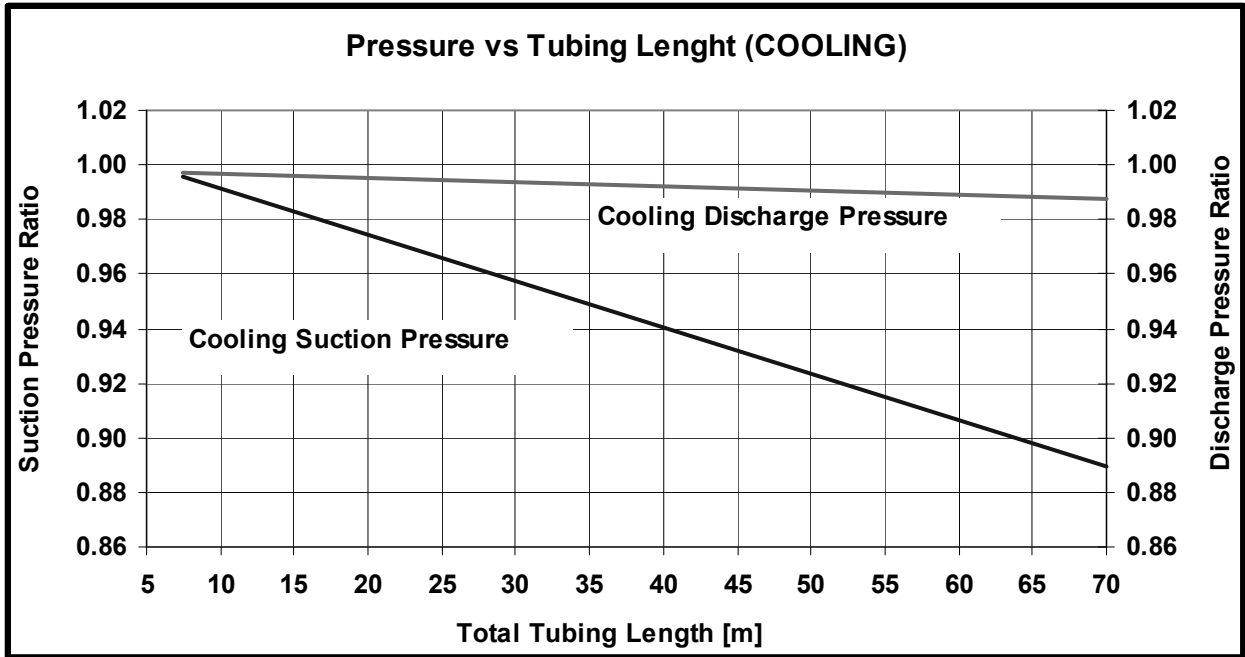

5.7.2 Heating

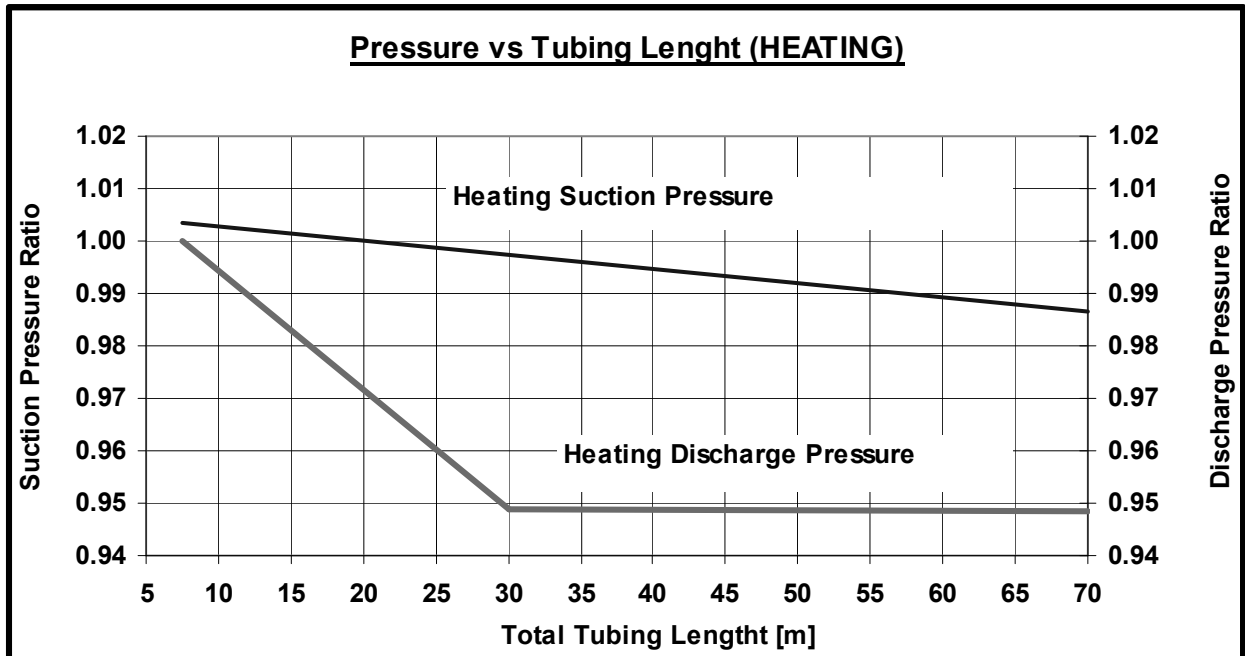

5.8 Calculation Example

Outdoor Unit	GC 43 DCI
Indoor Unit	DLS 43 DCI
Operation Mode	Cooling Mode
Conditions Indoor	22°CDB/15°WB
Conditions Outdoor	30°CDB
Tubing length	50m

Cooling Capacity calculation:

Total Cooling Capacity (TC) [KW] = Capacity in conditions table x F_T

Cooling Capacity in table [KW]	Tubing Length Factor (F_T)	Corrected Capacity [KW]
11.5	0.85	TC = 11.5x0.85=9.775

Cooling Pressure calculation:

Pressure [KPa(g)] = Nominal Pressure (at 7.5m) x F_T

Nominal Pressure [KPa(g)]		Tubing Length Factor (F_T)	Corrected Pressure [KPa(g)]
Discharge	2500	0.99	Pd= 2500 x 0.99 = 2475
Suction	800	0.925	Ps= 800 x 0.925 = 740

6. AIRFLOW CURVES

6.1 Model: DLS 36 DCI

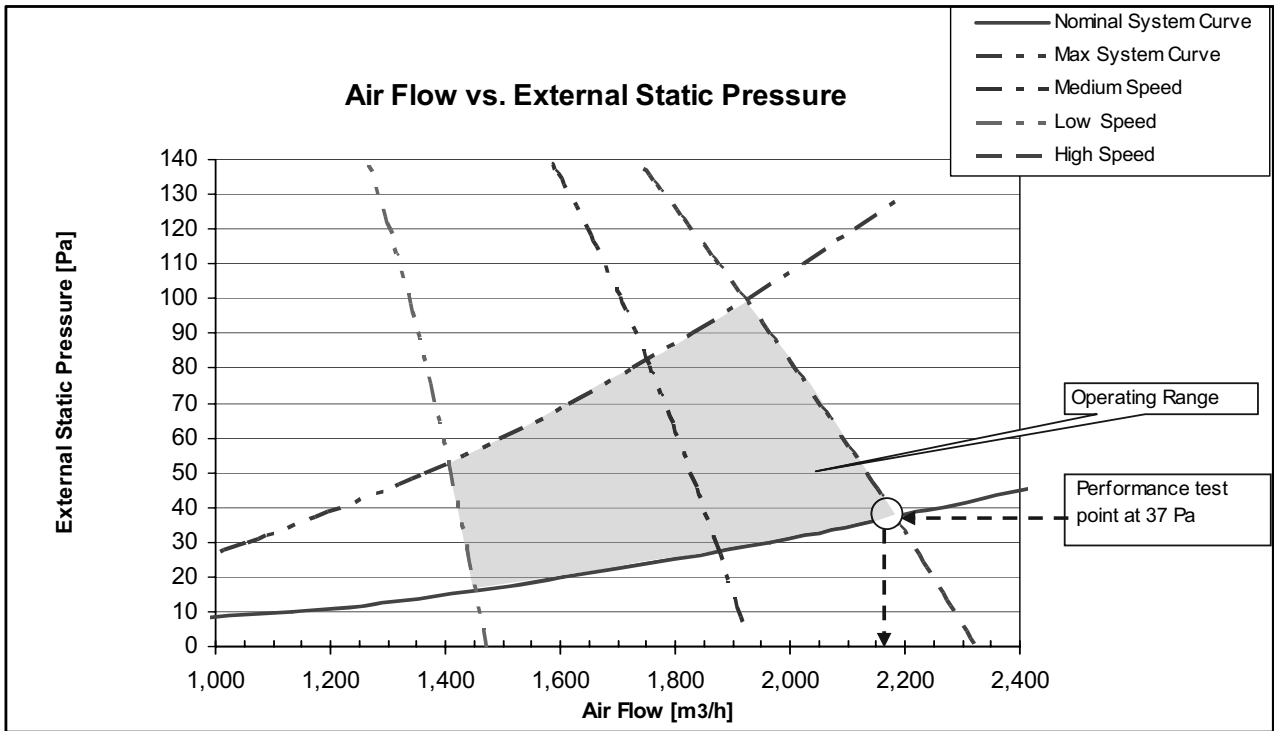

6.2 Model: DLS 43 DCI

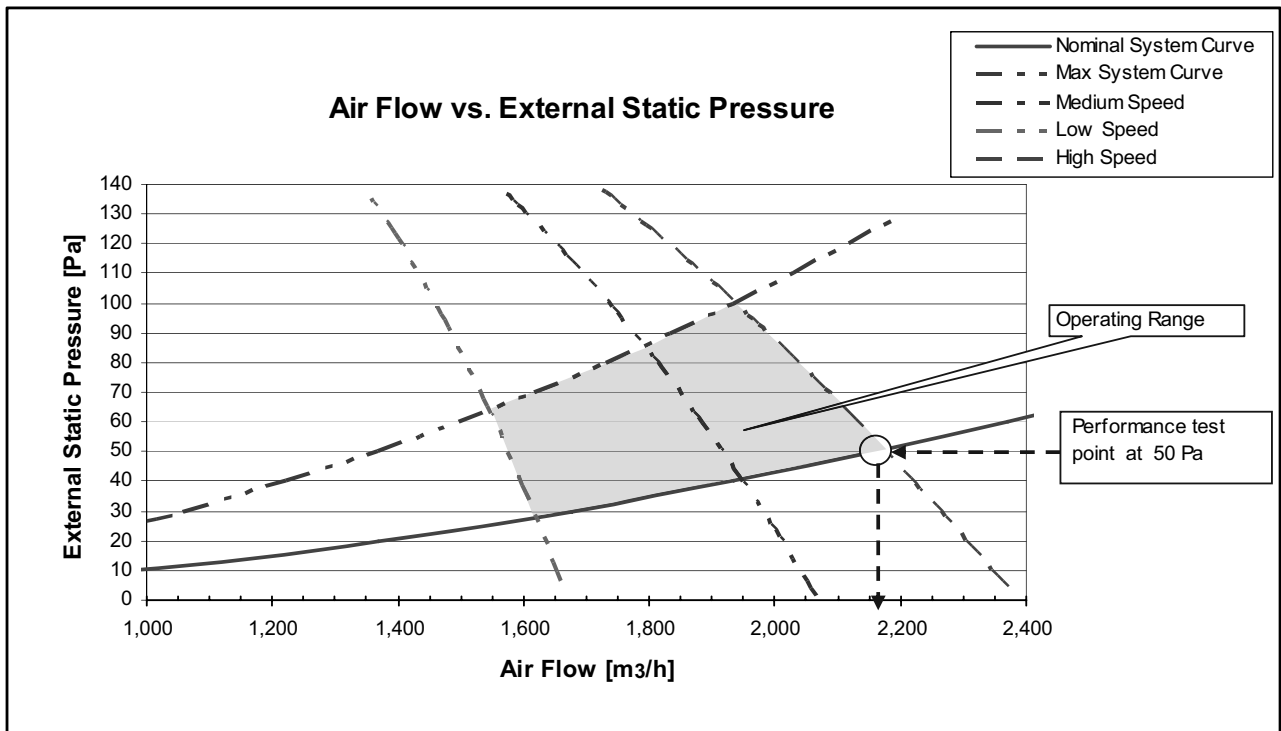

6.3 Model: DHC 36 DCI

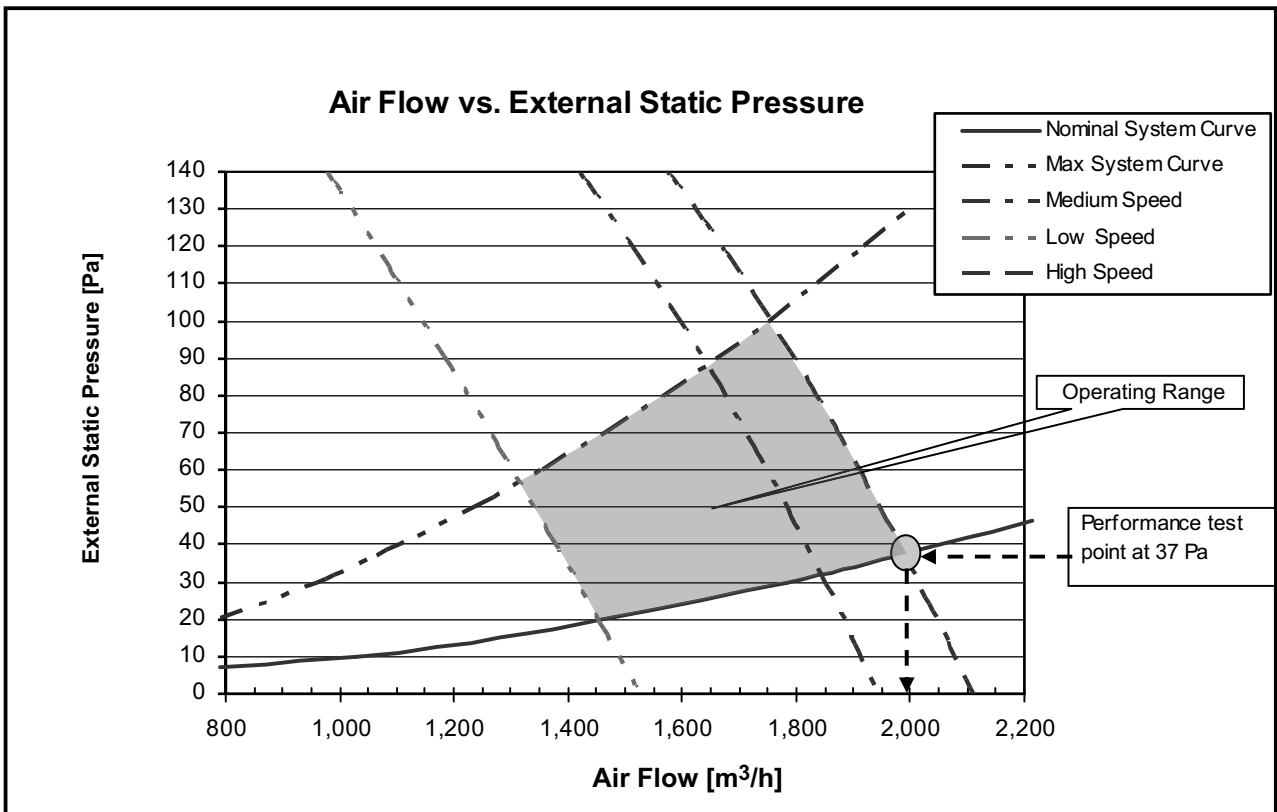

6.4 Model: DHC 43 DCI

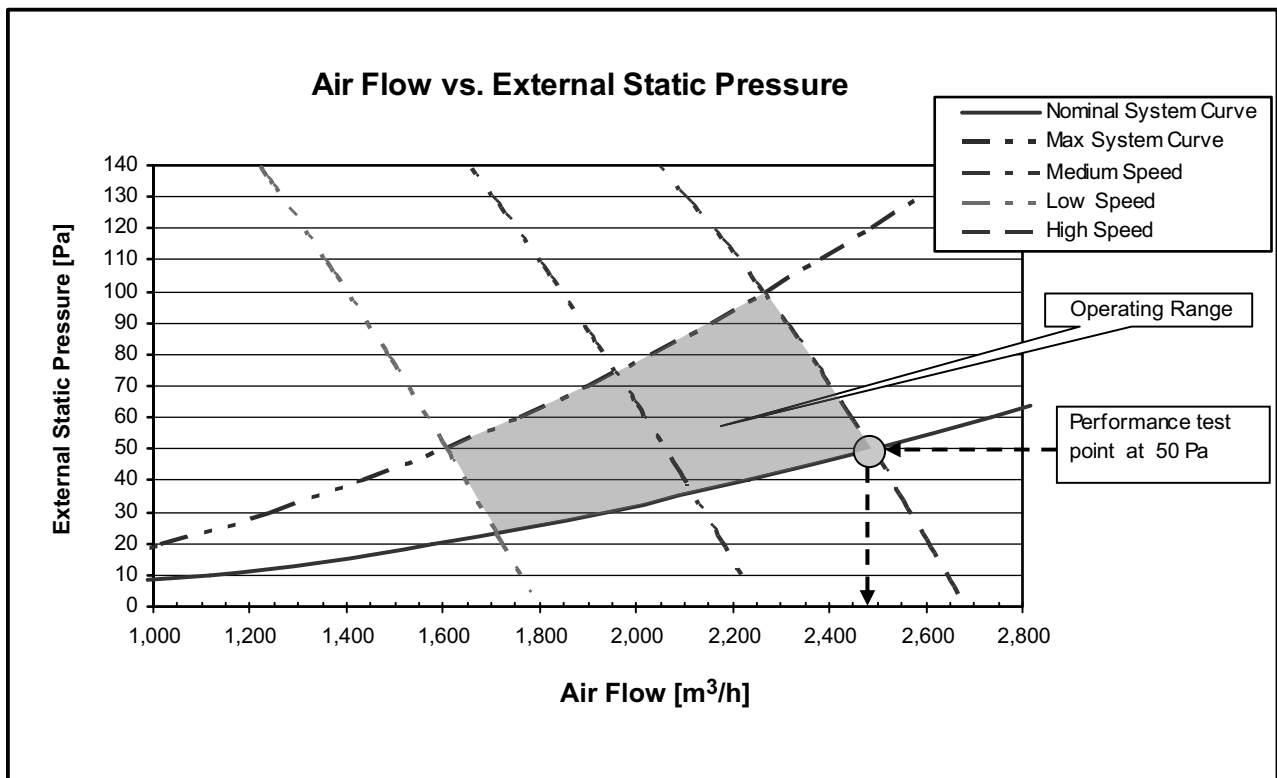

6.5 Model: CD 140 DCI

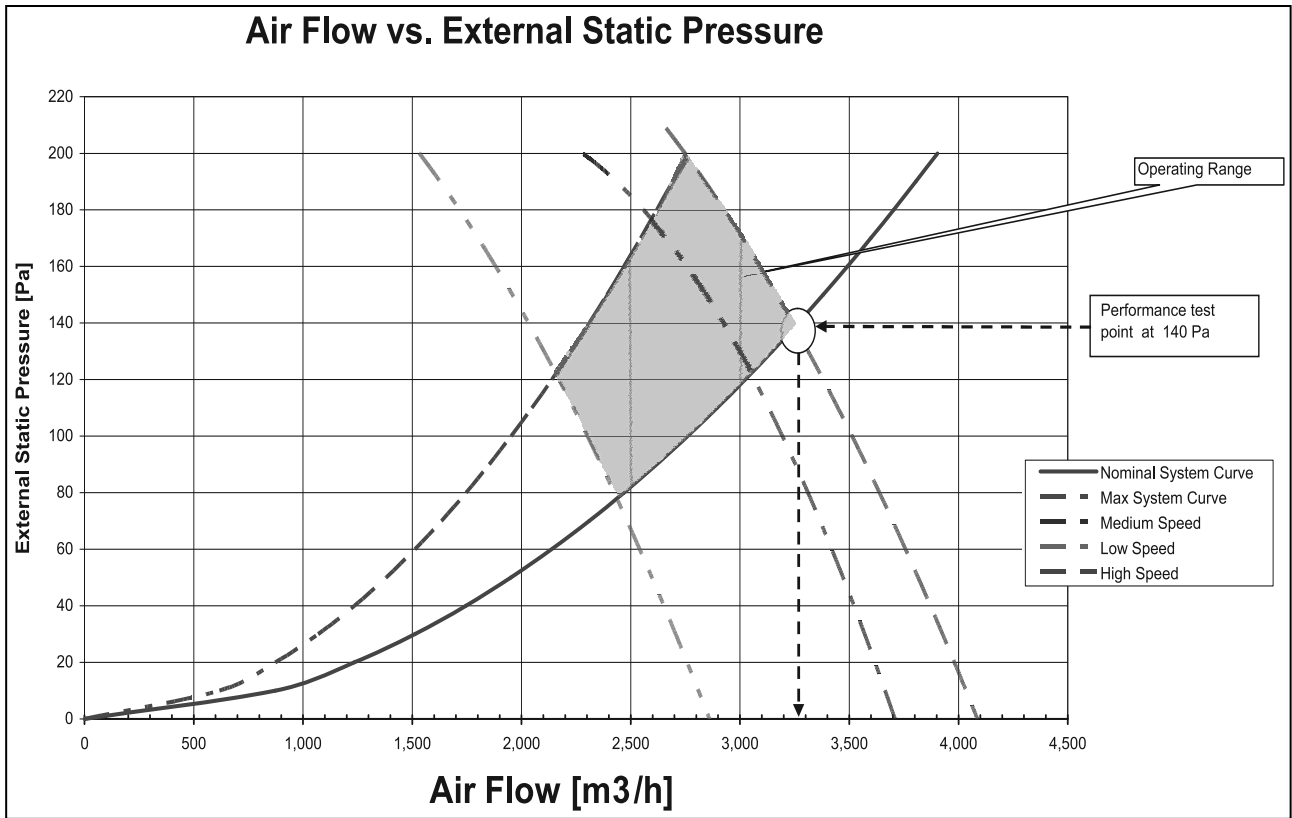

6.6 DLS / DHC / CD UNITS RANGE AIR FLOW CORRECTION FACTORS

(at nominal rating conditions — Test mode).

		Air Flow Rate [% of nominal]				
		60%	70%	80%	90%	100%
Cooling	TC	0.88	0.91	0.94	0.97	1
	SC	0.78	0.84	0.89	0.95	1
	PI	0.95	0.97	0.98	0.99	1
Heating	PI	1.07	1.05	1.03	1.02	1
	TC	0.90	0.92	0.95	0.97	1

* Permissible Air flow Rate - according to model Air Flow Curves

7. SOUND LEVEL CHARACTERISTICS

7.1 Indoor Units Test Scheme

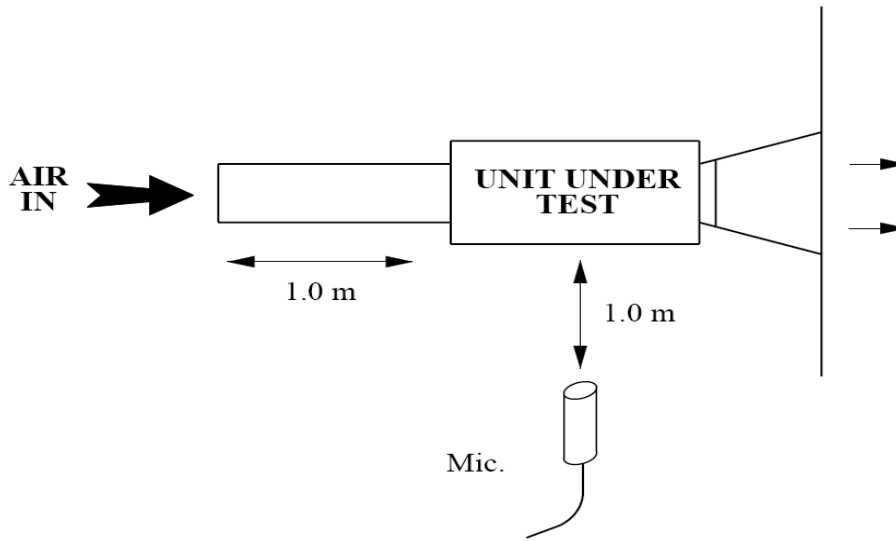
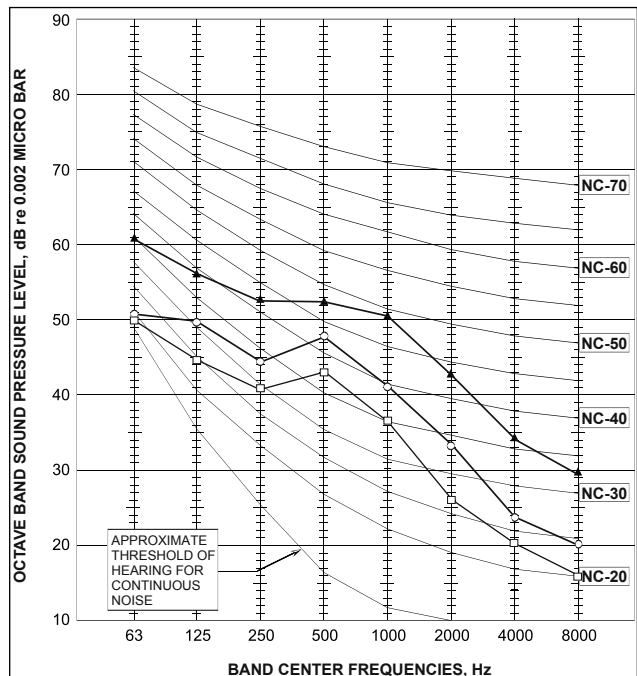
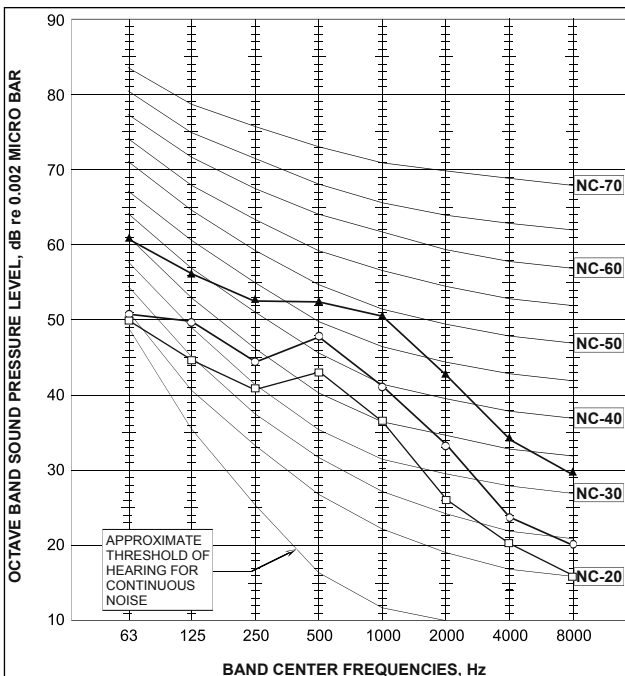

Figure 1

7.2 Sound Pressure Level Spectrum (Measured as Figure 1)

DLS 36

DLS 43



FAN SPEED	LINE
HI	—▲—
ME	—○—
LO	—□—

DHC 36

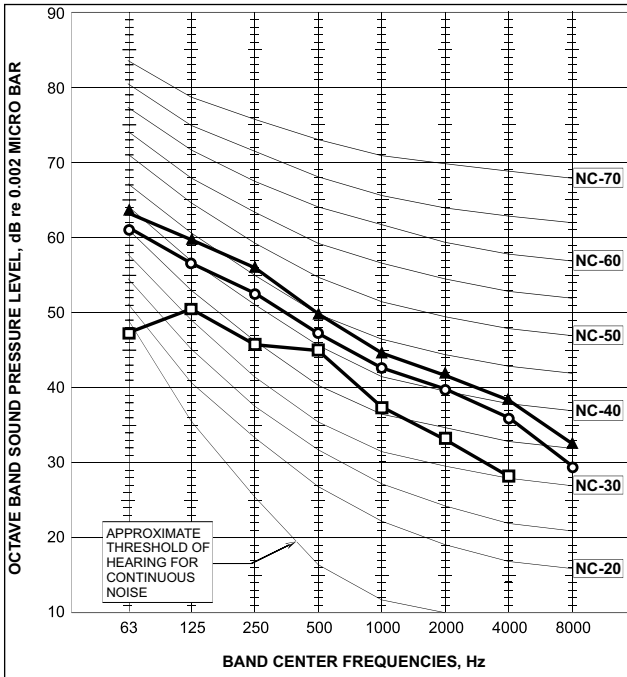

DHC 43

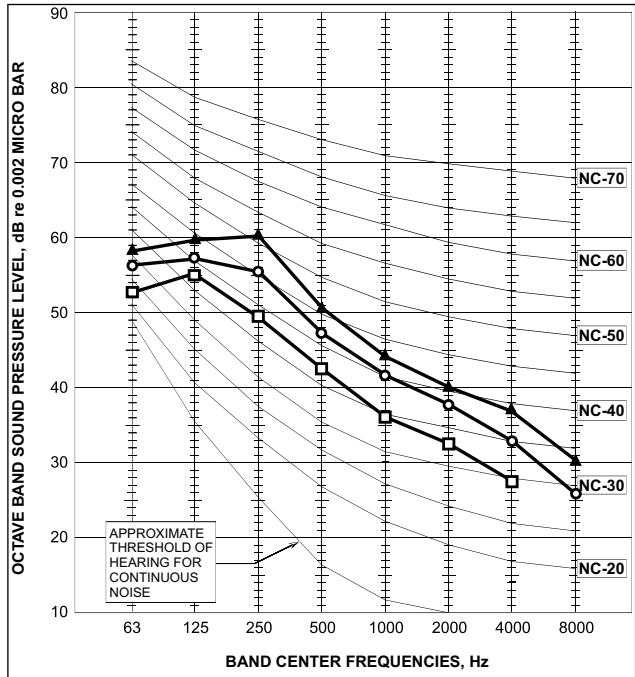

CD 60

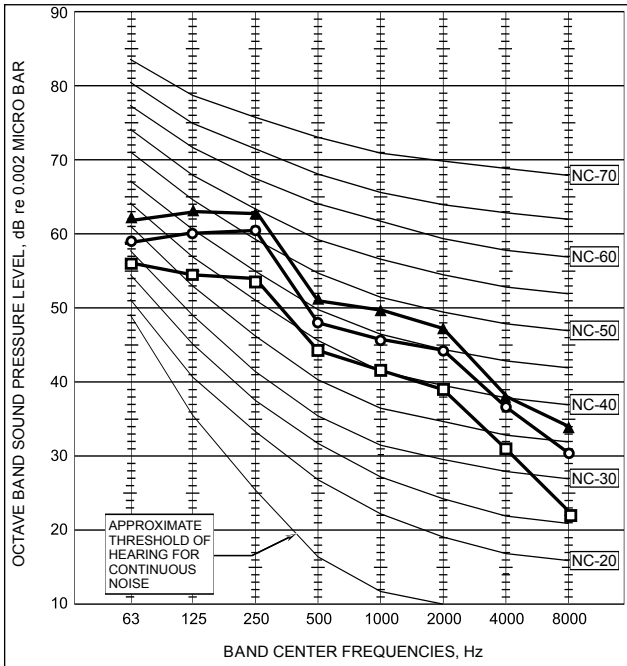

FAN SPEED	LINE
HI	▲
ME	○
LO	□

7.3 Outdoor Units

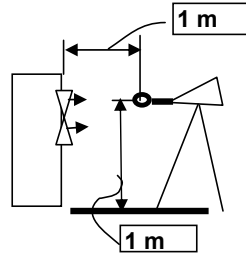
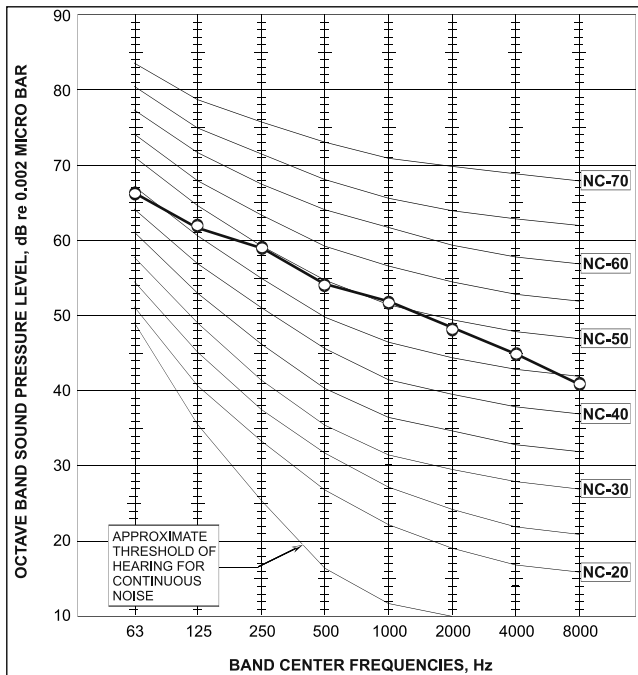

Figure 2

7.4 Sound Pressure Level Spectrum (Measured as Figure 2)

GC 36 DCI Cooling



GC 36 DCI Heating

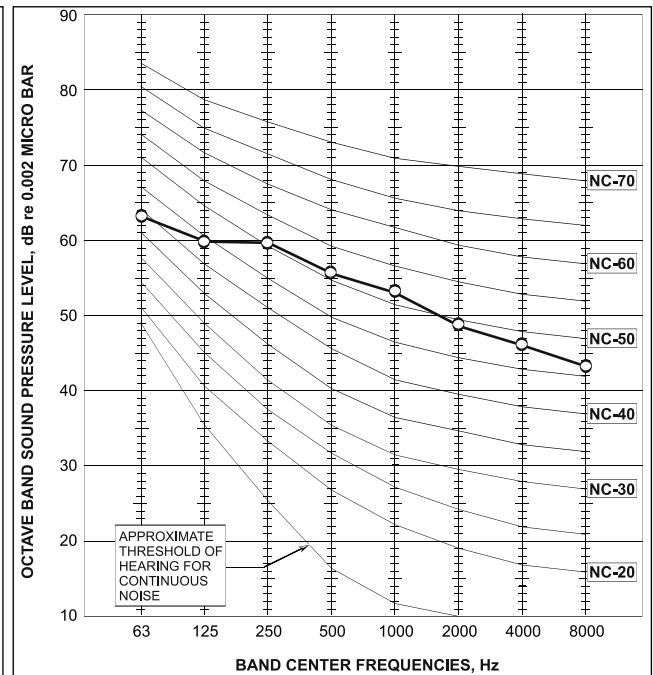

GC 43 DCI Cooling

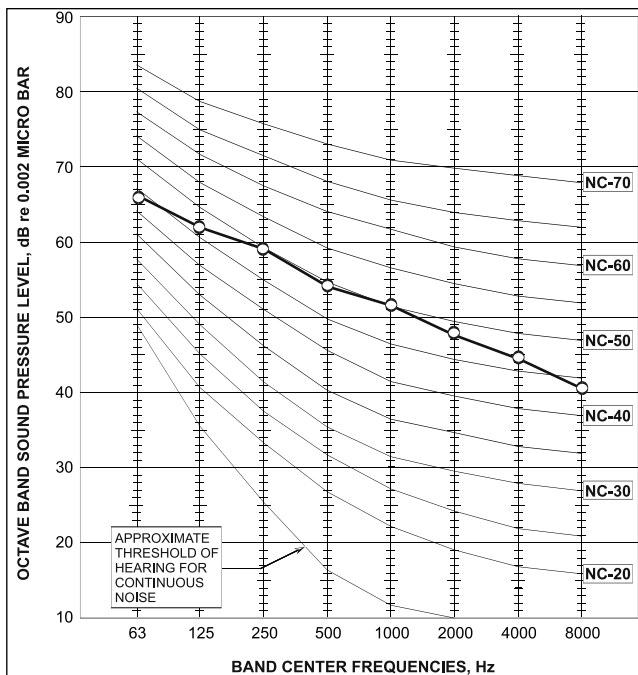

GC 43 DCI Heating

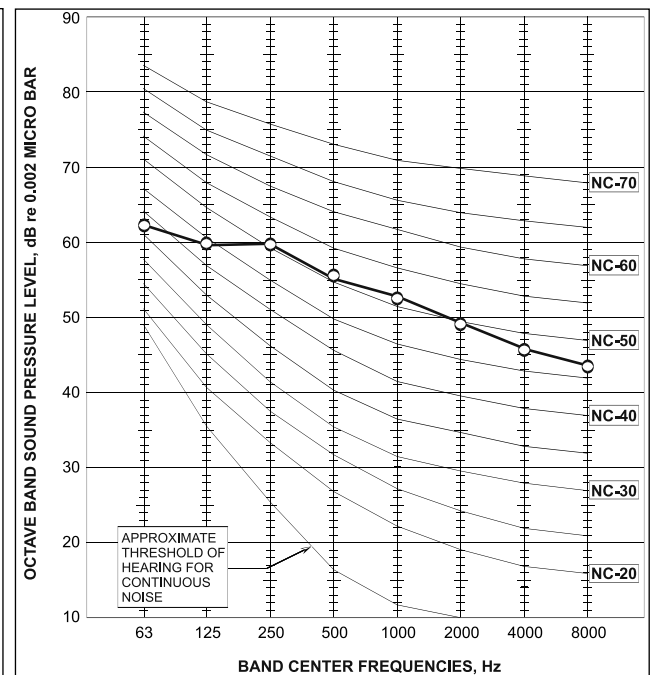

GC 60 DCI Cooling

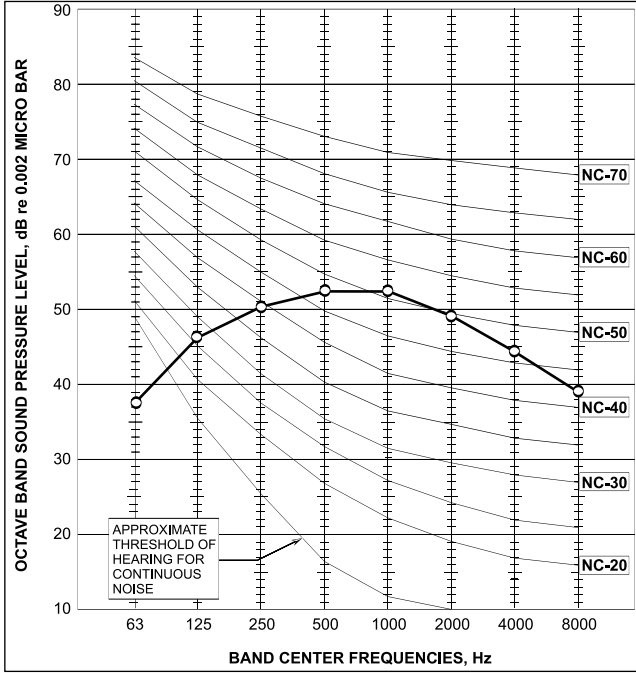

GC 60 DCI Heating

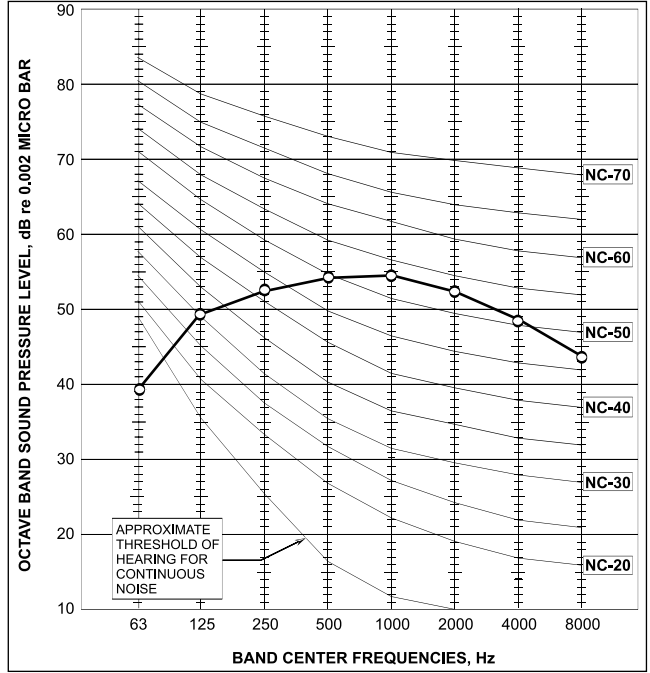

8. ELECTRICAL DATA

8.1 Single Phase Units

MODEL	GC 36 DCI		GC 43 / 60 DCI	
Power Supply	1PH – 230V – 50 Hz			
Connected to ^(a)	Outdoor	Indoor	Outdoor	Indoor
Max Current	23A	5A	28A	5A
Inrush Current ^(c)	30A			
Starting Current ^(d)	10A			
Circuit Breaker	25A	10A	32A	10A
Power Supply Wiring No. X Cross Section	3 X 4.0 mm ²	3 X 1.5 mm ²	3 X 6.0 mm ²	3 X 1.5 mm ²
Interconnecting Cable No. X Cross Section ^(b)	3 X 1.5 mm ² + 2 X 0.75 mm ² (Communications)	2 X 0.75 mm ² (Communications)	3 X 1.5 mm ² + 2 X 0.75 mm ² (Communications)	2 X 0.75 mm ² (Communications)

- (a) Power supply can be connected in both ways:
- ❖ To outdoor unit to supply both outdoor and indoor unit.
 - ❖ To outdoor unit and to Indoor unit separately.
- (b) Communication wires must be separated from the power wires and should be shielded type, earth connected at both ends.
- (c) Inrush current is the current when power is up (charging the DC capacitors at outdoor unit controller).
- (d) Starting current is the current peak when starting the compressor.

NOTE:

Power wiring cord should comply with local laws and electrical regulations requirements.

9. WIRING DIAGRAMS

9.1 Indoor Unit: DLS 36, DLS 43 DCI

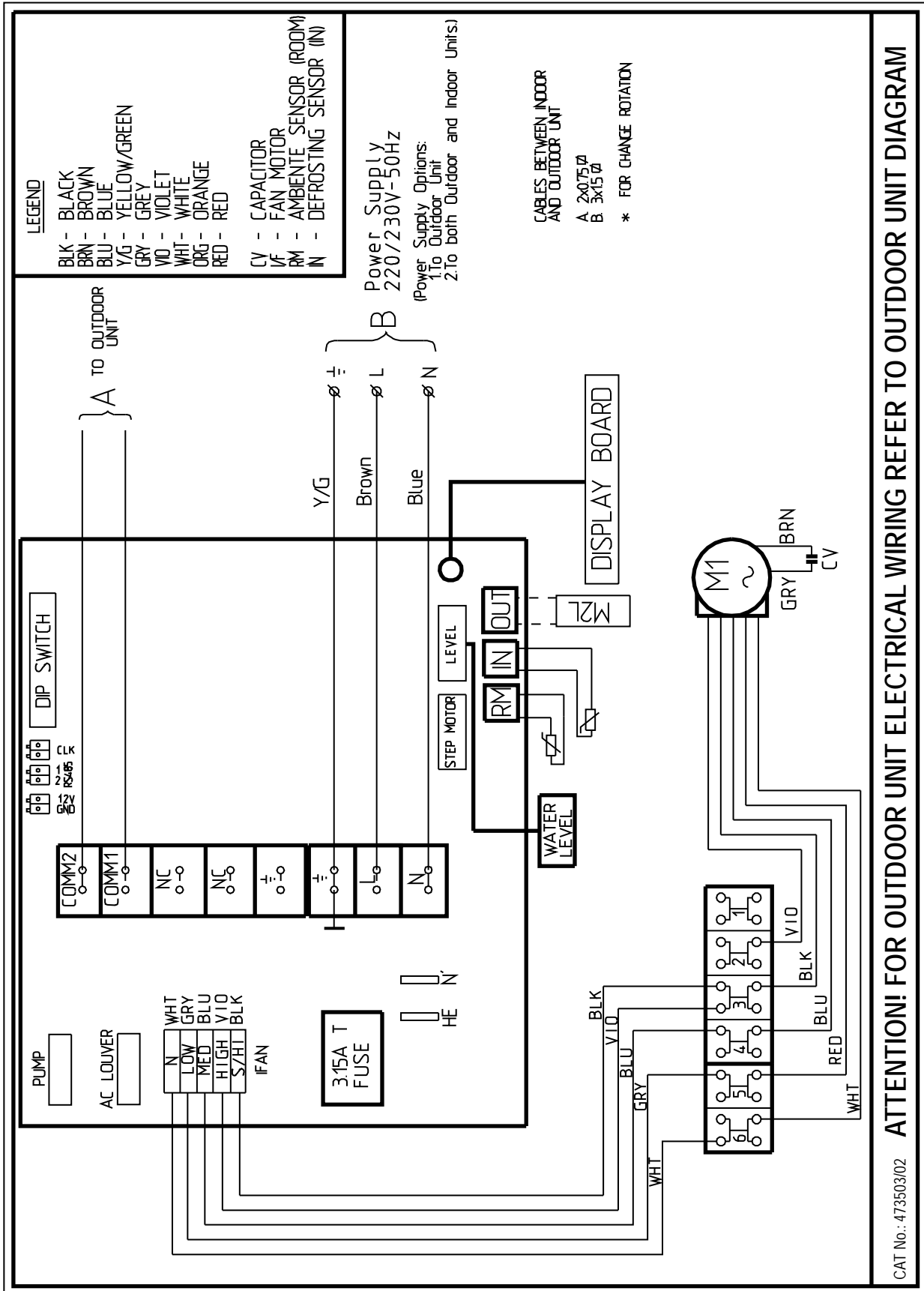

9.2 Indoor Unit: DHC 36, DHC 43 DCI

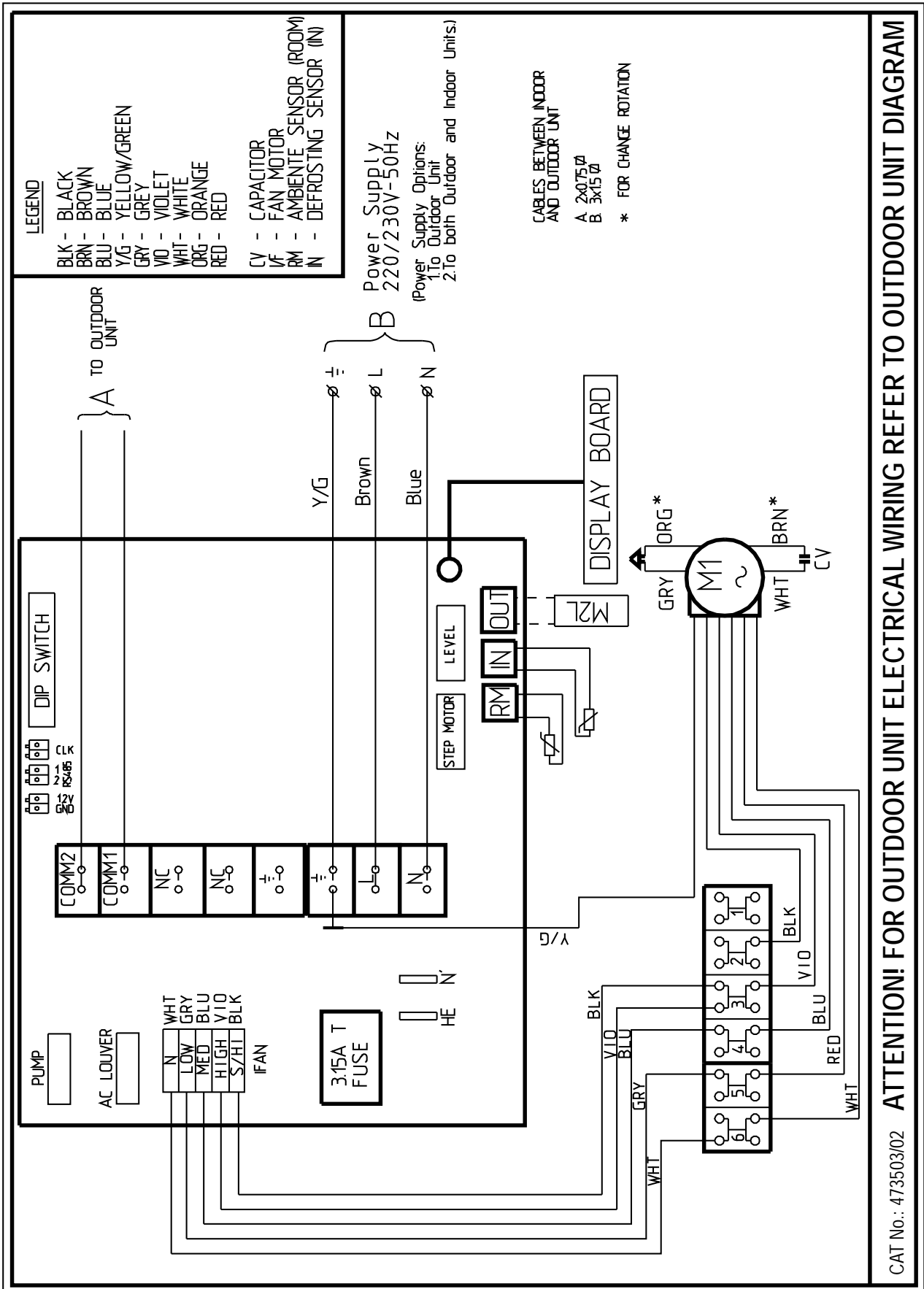

9.3 Indoor Units: CD 60 DCI

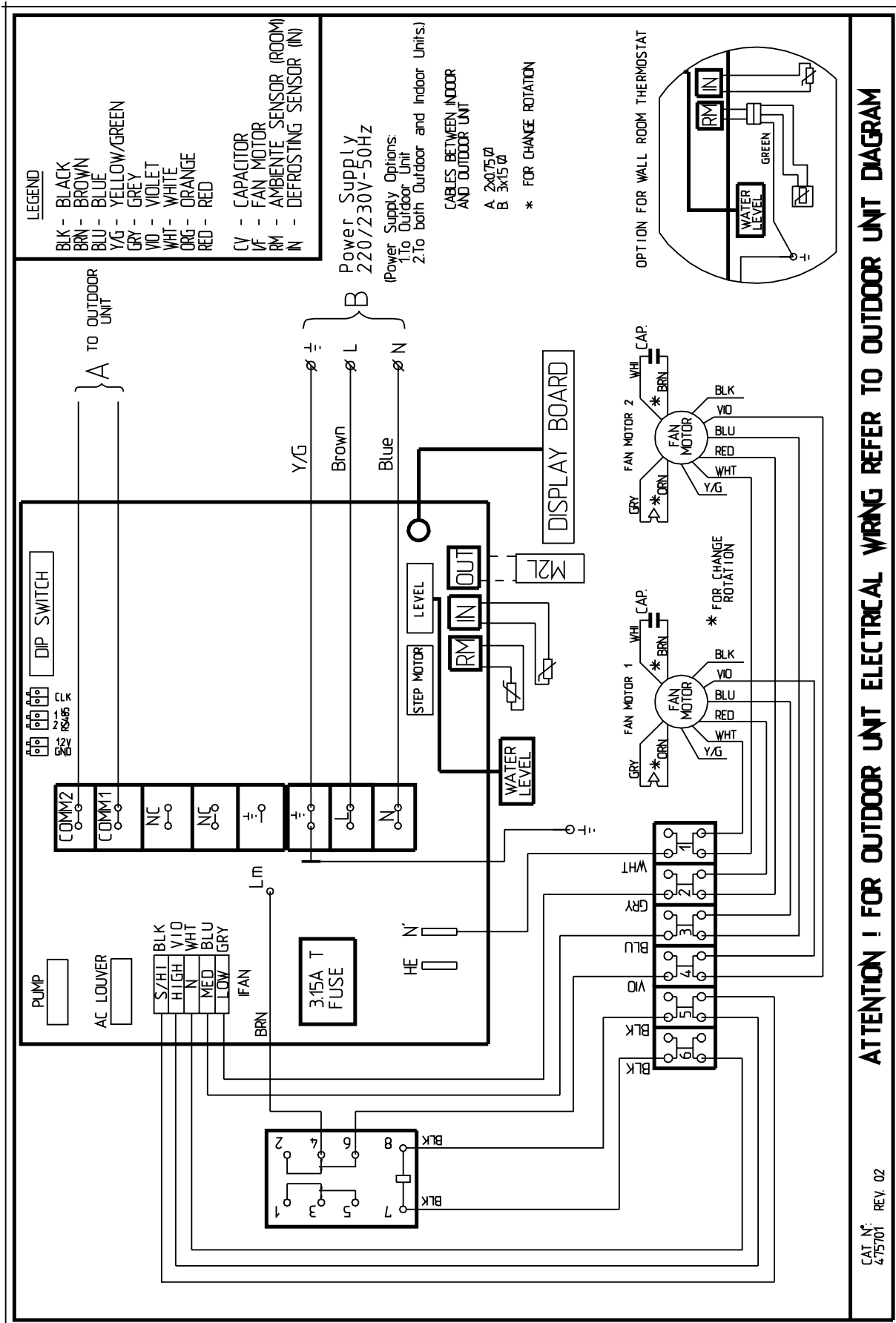

9.4 Outdoor Units: GC 36 / 43 DCI

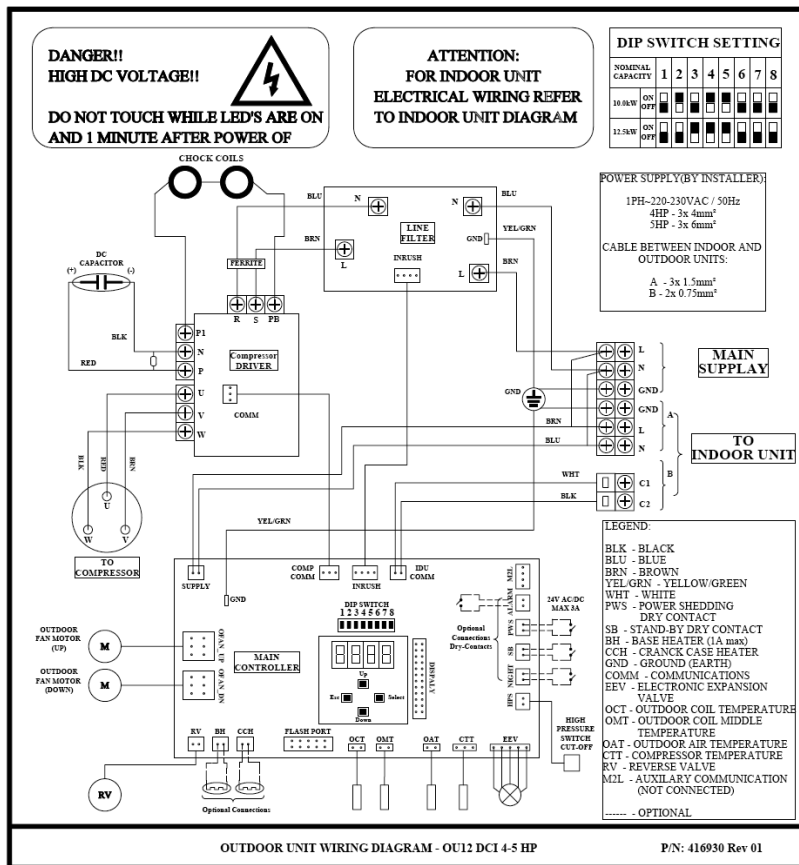

9.5 Outdoor Units: GC 60 DCI

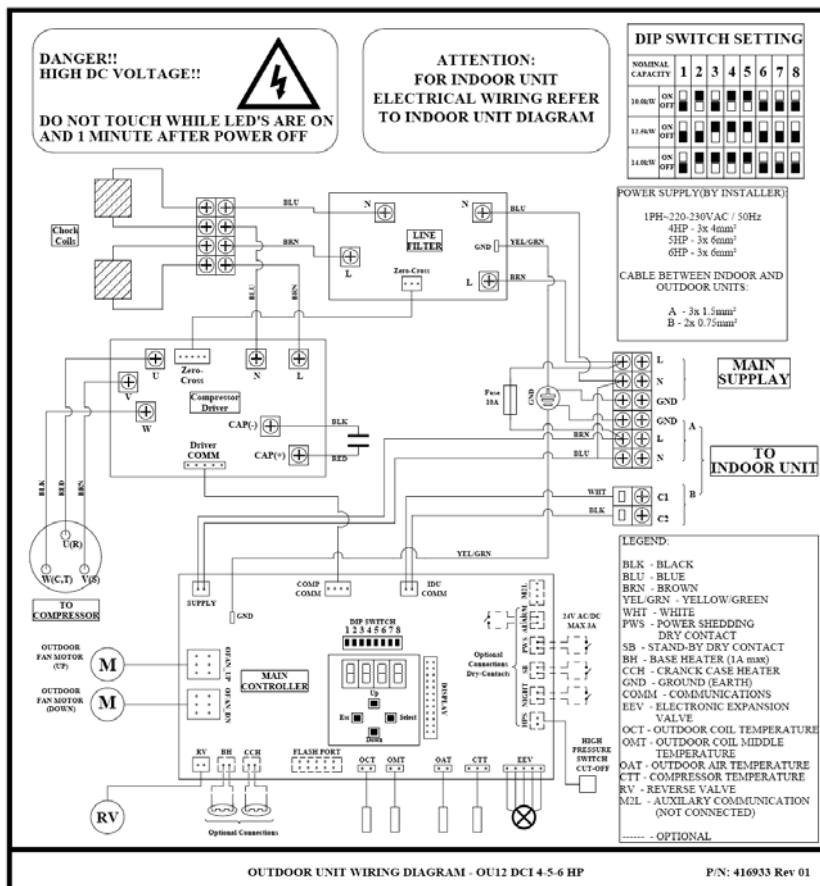

**9.6 1PH UNITS POWER SUPPLY TO OUTDOOR
(10.0, 12.5 Kw units)**

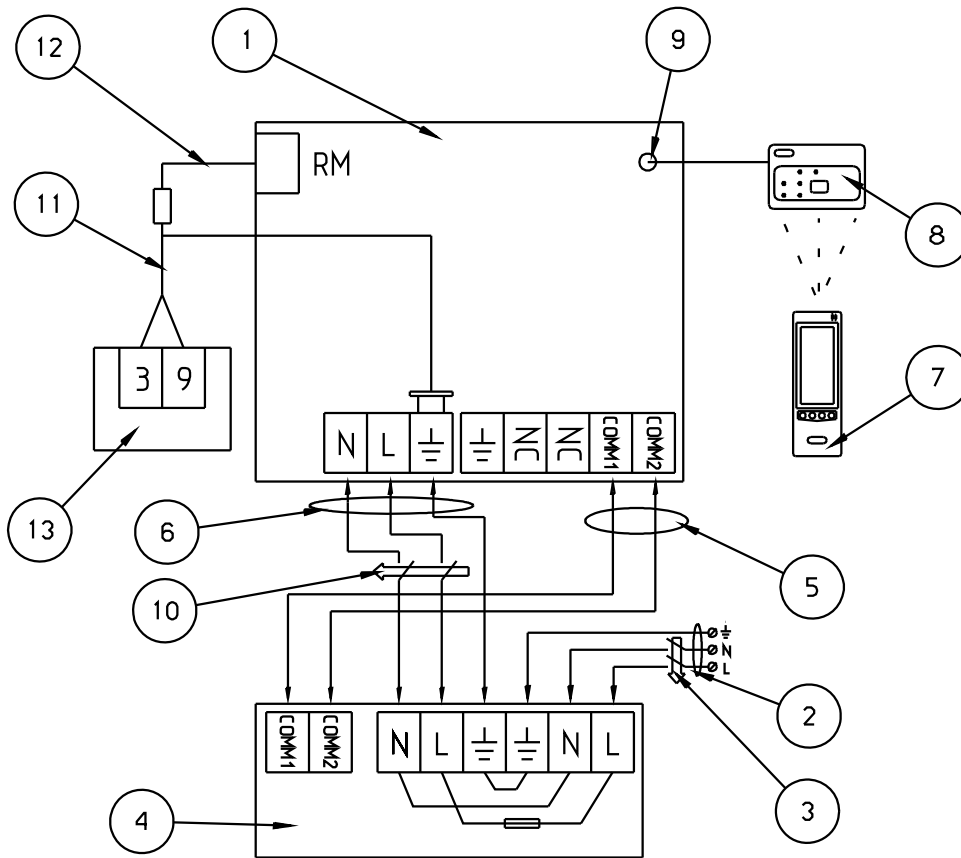

1. Indoor Unit
2. Power Supply Cable
3. Main Power Breaker
4. Outdoor Unit
5. Interconnecting cable (2x0.75mm²)**
6. Power Interconnecting Cable (3x1.5mm²)
7. Wireless remote Control
8. Display Unit
9. Display Connector
10. Power Breaker (*by installer)
11. Control Cable**
12. Sensor Wire with connector
13. Room Temperature Sensor

* The power breaker must be of type that disconnects all poles with 3 mm contact opening.

** Use shielded cable and connect the shield to earth point

**9.7 1PH UNITS POWER SUPPLY TO OUTDOOR and INDOOR UNIT SEPERATELY
(10.0, 12.5 Kw units)**

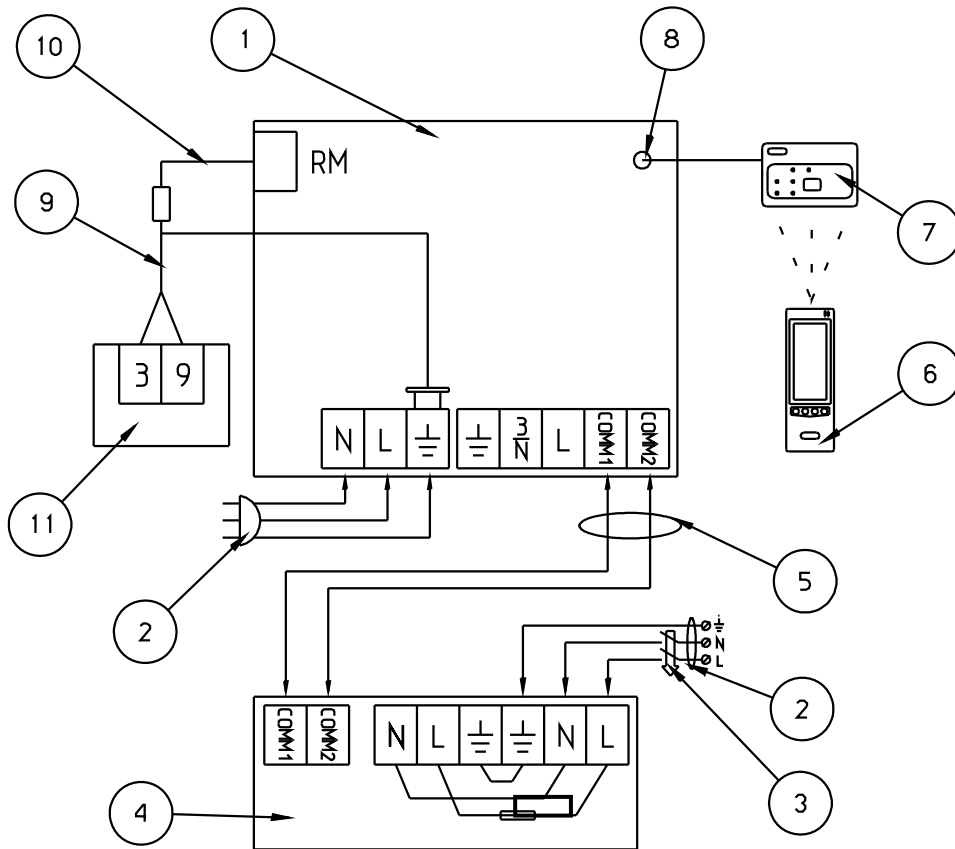

1. Indoor Unit
2. Power Supply Cable
3. Main Power Breaker
4. Outdoor Unit
5. Interconnecting cable (2x0.75mm²)*
6. Wireless remote Control
7. Display Unit
8. Display Connector
9. Control Cable*
10. Sensor Wire with connector
11. Room Temperature Sensor

* Use shielded cable and connect the shield to earth point.

10. REFRIGERATION DIAGRAMS

10.1 Heat Pump Models

10.1.1 DLS 36 / 43 DCI, EMD 36 / 43 DCI, CD 60 DCI

Cooling mode

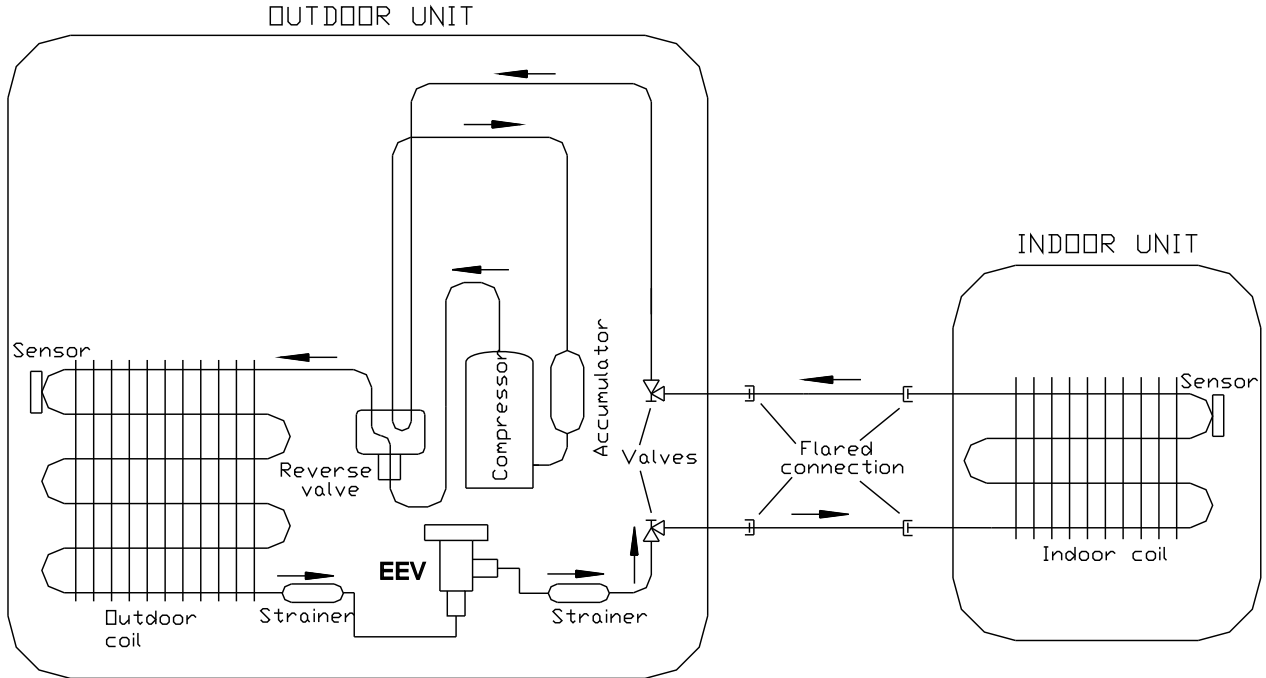

COOLING & DRY MODE

Heating mode

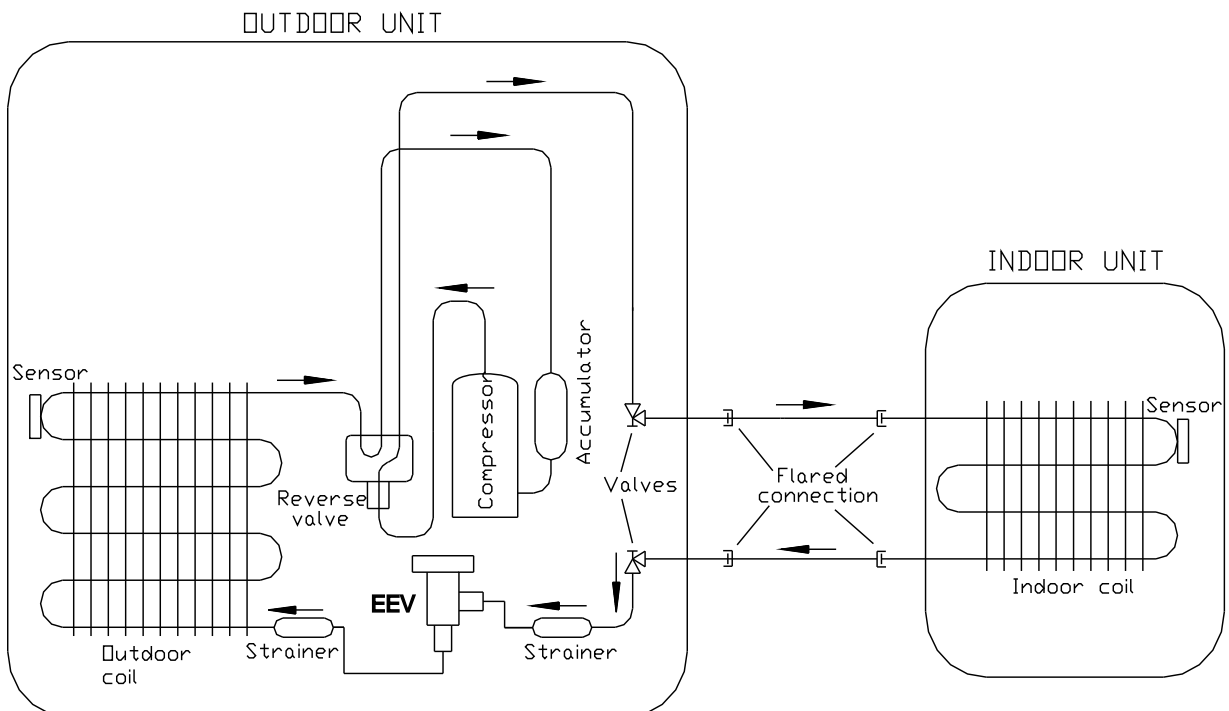

HEATING MODE

11. TUBING CONNECTIONS

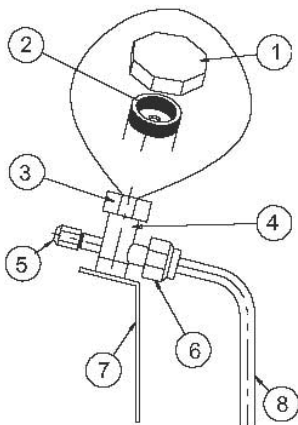
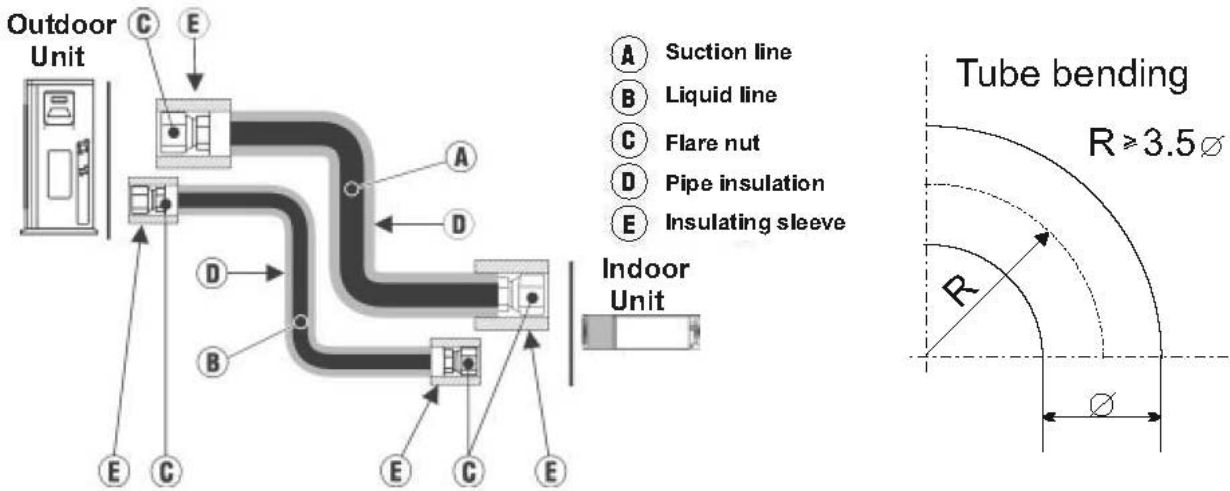

TUBE (Inch)	1/4"	3/8"	1/2"	5/8"	3/4"
TORQUE (Nm)					
Flare Nuts	15-18	40-45	60-65	70-75	80-85
Valve Cap	13-20	13-20	18-25	18-25	40-50
Service Port Cap	11-13	11-13	11-13	11-13	11-13

1. Valve Protection Cap-end
2. Refrigerant Valve Port (use Allen wrench to open/close)
3. Valve Protection Cap
4. Refrigerant Valve
5. Service Port Cap
6. Flare Nut
7. Unit Back Side
8. Copper Tube

12. CONTROL SYSTEM

12.1 Abbreviations

Abbreviation	Definition
A/C	Air Conditioner
BMS	Building Management System
CCR	Compressor Current
CCH	Crankcase Heater
COMP	Compressor
CTT	Compressor Top Temperature sensor
DCI	DC Inverter
E ² PROM, EEP	Erase Enable Programmable Read Only Memory
EEV	Electronic Expansion Valve
HE	Heating Element
HMI	Human Machine Interface
HST	Heat Sink Temperature sensor
Hz	Hertz (1/sec) – electrical frequency
ICT	Indoor Coil Temperature (RT2) sensor
IDU	Indoor Unit
IFAN	Indoor Fan
M2L	Mega Tool (Monitoring SW)
MCU	Micro Controller Unit
NA	Not Applicable
OAT	Outdoor Air Temperature sensor
OCT	ODU Coil Temperature sensor
OMT	Outdoor middle coil temperature
ODU	Outdoor Unit
OFAN	Outdoor Fan
PFC	Power Factor Corrector
RAC	Residential A/C
RC	Reverse Cycle (Heat Pump)
RPS	Rounds per second (mechanical speed)
RV	Reverse Valve
SB,STBY	Stand By
SH	Superheat
SUCT/SCT	Compressor Suction Temperature sensor
S/W	Software
TBD	To Be Defined
TEMP	Temperature
TMR	Timer

12.2 Product Overview

12.2.1 Block Diagram

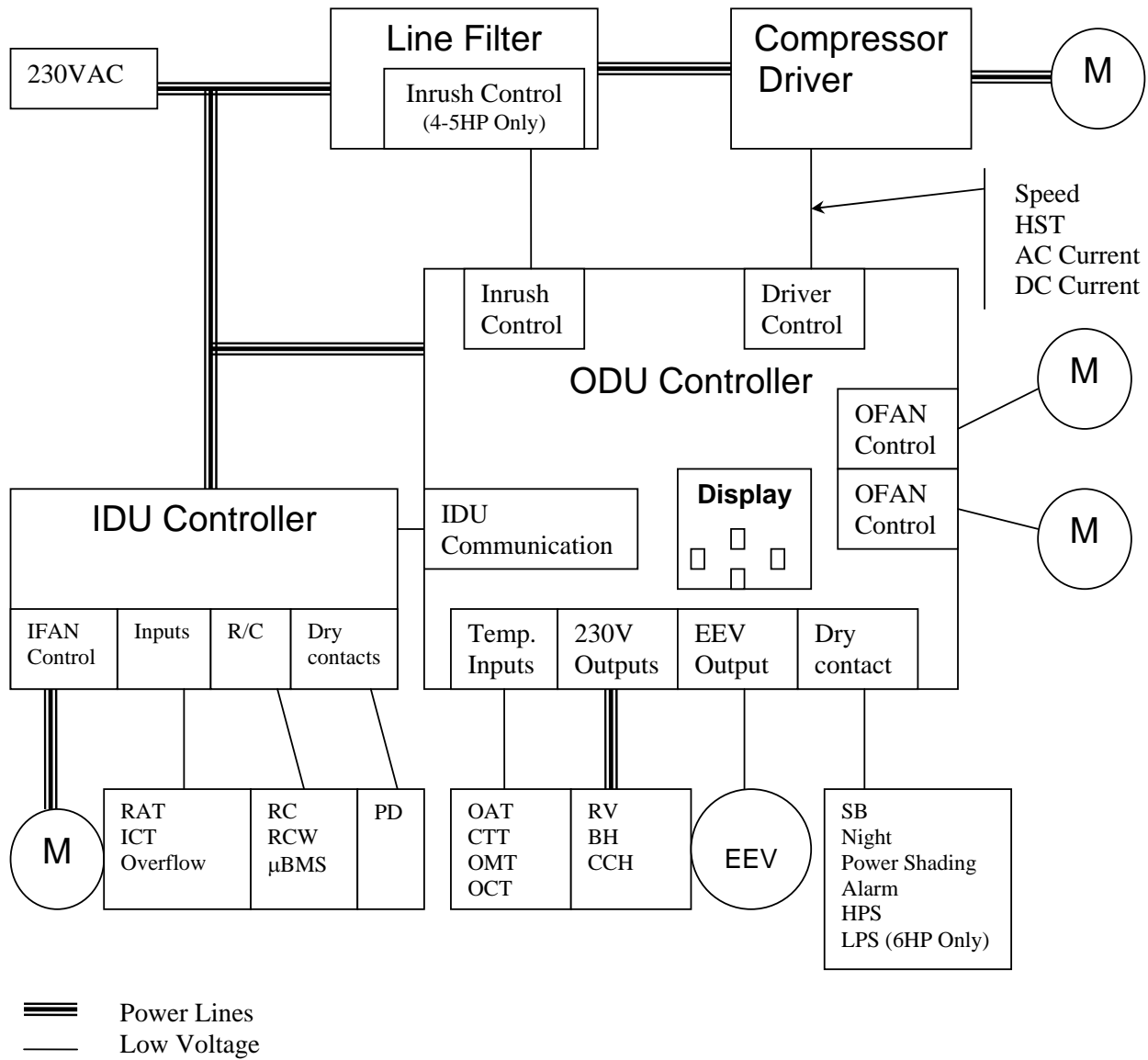

12.2.2 Compressor

DC brush less and sensor less motor inverter driven compressor.

12.2.3 Compressor Drive

DC inverter module to drive compressor.

12.2.4 Outdoor Fan

DC brush less motor.

12.2.5 RV

Reverse Valve set the direction of refrigerant flow in the system, thus setting the operation mode for cooling or heating.

When the solenoid is powered, system will work in heat mode.

12.2.6 EEV

Expansion valve operated by step motor which controls the size of the orifice.

12.2.7 HMI

Consists of Four “7-Segments” + four Push buttons for display, monitoring and setup features.

12.2.8 Dry Contacts

Dry contacts are used to interface the system with an external building management system (BMS).

12.2.8.1 ODU Dry Contacts

- **Night** input. Switches the system to night mode when closed. During night mode, the outdoor unit speed will be reduced in order to reduce the system noise level.
- **SB** input. System will be turned to Stand-by when the contact is closed.
- **Power Shedding** input. Limits the maximum power consumption when closed.
- **Alarm** output indicates a failure in the system.

Alarm output will be activated when there in the following ODU Faults/Protections 1 to 11, 13 to 20, 22 to 26, 28 to 29.

Alarm output will be OFF when the Fault/Protection is cleared.

12.2.8.2 IDU Dry Contacts

Presence detector input.

12.2.9 Temperature Sensors

CTT – Compressor Top Temperature
OAT – Outdoor Air Temperature
OCT – Outdoor Coil (heat exchanger inlet) Temperature
OMT – Outdoor Coil (heat exchanger) Temperature
HST – Heat Sink Temperature
ICT – Indoor Coil (heat exchanger) Temperature
RAT – Return Air Temperature (Indoor Unit)

12.2.10 Base Heater

Heating element designed to melt any ice that is accumulated on the outdoor unit base during low heating operation.

12.2.11 Cranck case Heater

Heating element designed to heat up the compressor oil cranck case during low heating operation.

12.2.12 Internal coil heater

Only exists in 6HP unit. The compressor is equipped with built-in heating coils designed to heatup the compressor oil cranck case during low heating operation.

12.3 General Operating Rules

12.3.1 Communication with Indoor Unit

12.3.1.1 Communication Failures Definition

12.3.1.1.1 'Bad Communication' fault

The system keeps a balance of a good/bad communication packet ratio. When the ratio becomes high the system enters 'Bad Communication' fault. The system recovers from that fault when the ratio reduced below the threshold.

When in 'Bad Communication' fault, system continues its normal operation and fault code is shown in diagnostics.

12.3.1.1.2 'No Communication' fault

If no legal transmission or no message received for 30 seconds, system enters 'No Communication' fault.

When in 'No Communication' fault, the fault code will be shown in diagnostics. In this case, the system will force the compressor to off.

The system will recover from 'No Communication' fault when counter is below 10 and legal message is received

12.3.2 Temperature Measurements

12.3.2.1 Thermistor failures definition

Thermistor	Thermistor is Disconnected	Thermistor is Shorted
OCT	Temp < -35 °C	Temp > 75 °C
OAT	Temp < -30 °C	Temp > 75 °C
CTT	Temp < -30 °C	Temp > 130 °C
OMT	Temp < -30 °C	Temp > 75 °C
ICT	Temp < -30 °C	Temp > 75 °C
RAT	Temp < -30 °C	Temp > 75 °C

12.3.2.2 System responses for different thermistor failure

Thermistor	Default value		System Reaction
	COOL	HEAT	
OCT	1°C	1°C	(1)
OAT	43°C	6°C	
CTT	43°C	43°C	Forced compressor to OFF
HST	75°C	75°C	
OMT	43°C	43°C	Replaced by OCT (1)
ICT	43°C	43°C	
RAT	SPT+4°C	SPT-4°C	

Notes:

(1) Whenever both OCT and OMT are faulty the compressor will be forced to OFF.

- (2) Thermistor is defined as faulty (shorted/disconnected) if it's faulty for more than 10 seconds continuously. During this time, the system uses the last valid temperature.

12.4 Indoor Unit Control

12.4.1 Indoor Fan Control

When user sets the indoor fan speed to a fixed speed (Low/ Medium/ High), unit will operate constantly at set speed.

When Auto Fan is selected, indoor fan will operate in all speeds according to the cool/heat load.

12.4.2 Load calculation

LOAD is calculated according to the difference between actual room temperature and user set point temperature by PI control.

In high/ medium/ low indoor fan user setting, unit will operate fan in selected speed.

In AutoFan user setting, fan speed will be adjusted automatically according to the calculated LOAD.

12.4.3 Heat Mode

12.4.3.1 Temperature Compensation

A compensation value of 2-4 degrees is reduced from room temperature reading (except when in I-Feel mode), to compensate for temperature difference between high and low areas in the heated room, and for coil heat radiation on room thermistor.

The temperature compensation can be enabled/disabled by closing/opening J2 on the indoor unit controller.

12.4.3.2 Indoor Fan Control in Heat Mode

When in heat mode, including protections and except Deicing, and when the conditions in the table below are fulfilled, IFAN will be working according to the graph below.

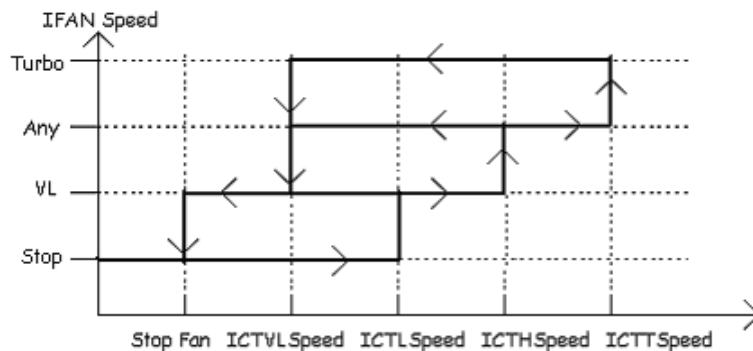

12.4.4 Auto Cool/Heat Mode

When in auto cool heat mode unit will automatically select between cool and heat mode according to the difference between actual room temperature and user set point temperature (ΔT).

Unit will switch from cool to heat when compressor is off for 3 minutes, and $\Delta T < -3$.

Unit will switch from heat to cool when compressor is off for 5 minutes, and $\Delta T < -3$.

12.4.5 Dry Mode

As long as room temperature is higher then the set point, indoor fan will work in low speed and compressor will work between 0 and maximum frequency in cooling.

When the room temperature is lower than the set point, compressor will be switched OFF and indoor fan will cycle 3 minutes OFF, 1 minute ON.

12.4.6 Heating Element Control

Heating element can be turn on if high LOAD is more then 80% and Indoor Coil temperature is less then 45°C.

The heating element will be off when LOAD is less then 50% OR if Indoor Coil temperature is more then 50°C.

12.4.7 Indoor Unit Dry Contact

“Presence Detector” feature in the indoor unit is done for cases that external SB (Stand-By) is required via a presence detector sensor or others such as window closed detector, etc.

The dry contact can be set to operate if the contacts are shorted as follows:

Function	Contact = Open	Contact = Short
Presence Detector Connection	No Action – normal operation (Default)	Forced to STBY

Notes:

- o When the A/C is forced to STBY mode, all R/C commands are ignored, and the operation LED blinks with 1 seconds cycle time.
- o Any change in the Presence Detector state during the first 6 sec after the system reset is ignored.

12.4.8 Operating the Unit from the Mode Button

Forced operation allows to start, stop and operate in Cooling or Heating, in pre-set temperature according to the following table:

Forced operation Mode	Pre-set Temperature
Cooling	20°C
Heating	28°C

12.4.9 On Unit Controls and Indicators

Indications during OFF, Fan, Cool, Heat, Dry, and Auto modes are shown below. For operation in other modes, check the relevant paragraphs.

STANDBY INDICATOR	Lights up when the Air Conditioner is connected to power and is ready for operation
OPERATE INDICATOR	<ol style="list-style-type: none"> 1. Lights up during operation. 2. Blinks for 300 msec to announce that a R/C infrared signal has been received and stored. 3. Blinks continuously during protections (according to the relevant spec section).
TIMER INDICATOR	Lights up during Timer and Sleep operation.
COOLING INDICATOR	Lights up when system is switched to Cool Mode by using the Mode Switch <u>on the unit</u> .
HEATING INDICATOR	Lights up when system is switched to Heat Mode by using the Mode Switch <u>on the unit</u> .
Mode SWITCH (COOL/HEAT/OFF)	<p>Every short pressing , the next operation mode is selected, in this order : SB → Cool Mode → Heat Mode → SB → ...</p> <p>In long pressing system enters diagnostic mode.</p>

12.5 Run Mode

Run mode is the default operation mode of the system. This is the standard operation mode that is active in field application (at customer site).

System can go from run mode to other operation modes through keyboard or serial ports.

12.5.1 Mode Setting

Mode defines the ODU operation mode. There are three possible operation modes:

1. STBY – standby mode
2. COOL - the unit operating at cooling cycle
3. HEAT - the unit operating at heat pump cycle

SB mode can be set also by dry-contact.

12.5.1.1 ODU Protections

There are 4 ODU protections:

- Compressor overheating
- Heat sink overheating
- AC over current
- DC Over curren – not in 6HP unit

12.5.2 Compressor Speed Control

12.5.2.1 Compressor Min On/Off time

Compressor minimum OFF time is 3 minutes except during Deicing protection.

Compressor minimum ON time is 3 minutes, minimum ON time is ignored during protections, and when unit is turned to STBY.

12.5.2.2 Compressor Startup

When started, compressor speed reaches 40 RPS and will not go below that during the first 5 minutes of compressor operation except when compressor forced OFF.

12.5.2.3 Compressor start up fail

If the compressor does not succeed to complete the startup procedure, it will report a compressor-lock fault code.

It than retries the startup procedure for 3 times on every 10 seconds and enter a 3 minutes wait condition before starting the next compressor startup sequence.

12.5.2.4 Compressor operation while OFAN Error

In case an OFAN error a cured for 10 continues seconds and the compressor is on, the compressor will be set to OFF until OFAN error will recover.

12.5.2.5 Maximum allowed speed limitation

For cool mode:

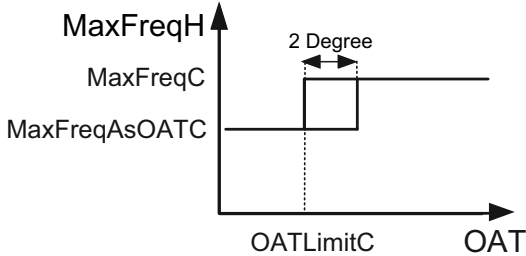

For Heat mode:

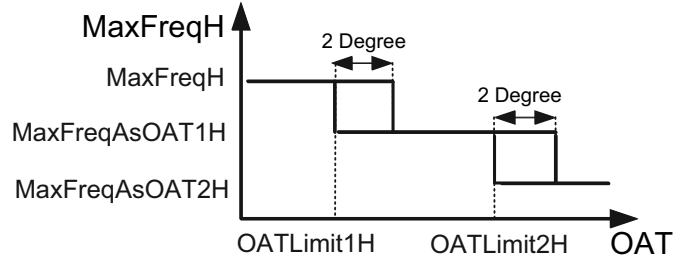

Note: If OAT is faulty, there will be no limits.

12.5.2.6 Speed Change Limitations

When rising or lowering speed within the allowed operating range, the acceleration or deceleration will be 1 RPS/sec.

12.5.2.7 Compressor Speed calculation

During normal operation (excluding protections) the compressor target speed is set according to the NLOAD number received from the indoor unit and CompFac. CompFac is an indoor-outdoor matching parameter, once it is 0, the compressor will be forced off, if it is number between 0.01 to1, the compressor target frequency is set by the following table.

NLOAD	Target Speed [Hz]
<10	0
10	MinFreqC in cool OR MinFreqH in heat mode
11– 126	NLOAD*CompFac
127	MaxFreqC in cool OR MaxFreqH in heat mode

12.5.2.8 Speed Step Limitations

The compressor speed have some step limitations which it will not go above them for few minuits after startup.

12.5.2.9 Compressor shutdown Procedure

There are 2 procedures for compressor shutdown:

1. Immediate shutdown – compressor is stopped on the spot.
2. Gradual shutdown – compressor speed is reduced gradually to the minimum speed by NormAccel Hz/sec and then stops.

#	Shutdown Reason	Shutdown procedure	
1	IDU NLOAD=0 (or IDU protections)	Gradual	Minimum On time is kept.
2	IDU Shutdown (idle)	Immediate	
3	Deicing	Immediate	
4	ODU Protections	Gradual	
5	Sensor faulty (CTT or OCT+OMT)	Immediate	
6	HPS protection	Immediate	
7	LPS protection	Gradual	(Only in 6HP units)

12.5.3 EEV Control

12.5.3.1 EEV General Rules

The EEV is controlled to keep the discharge superheat temperature within preset control values.

12.5.3.2 EEV initialization procedure

After power up the EEV performs initialization procedure while it closed completely and reopened to predefined position. During initialization, the compressor is forced to off.

12.5.3.3 Balance time

During the first minutes after SB the correction is not calculated. After that the correction value is updated every *EEVCVTConst* seconds.

12.5.3.4 Operation Range

The EEV operation range is defined according to the operation mode as following

ODU Mode	Normal operation	Notes
SB	450	<i>May change according to model</i>
COOL	60 to 480	
HEAT	60 to 480	

12.5.3.5 EEV initial value determination (EEV_{OL})

The EEV initial value (open loop) is determined according to the operation mode, the actual frequency and ODU model. The values are determined according to the “EEV_{OL} Parameters Table”.

12.5.3.6 EEV opening determination in normal run mode

The target EEV value is the sum of open loop value (OL) and a result of the accumulative correction values (CV). The EEV corrections are calculated every *EEVCVTConst* seconds.

$$EEV = EEV_{OL} + \sum EEV_{CV}$$

12.5.4 Outdoor Fan Speed Control

12.5.4.1 Speed Definition

The outdoor fans can work in 16 speed states controlled by OMT sensor in cool mode and ICT sensor in heat mode in relation to outdoor conditions.

12.5.4.2 General Rules

- ❖ The fans will be off when the compressor is off unless HST>55 or faulty and than OFAN_up will remain ON.
- ❖ Min time for speed change between speed states is 60 seconds.
- ❖ The fan speed is also related to protections.
- ❖ Whenever OFAN fault occurs the compressor will be stopped.

12.5.4.3 Night mode

During night mode, the OFAN and the compressor will be limited to lower speeds (Cool model only).

12.5.5 RV State Setting

During heat mode (except during Deicing) RV is ON.

During cool/SB mode RV is OFF.

RV status will be changed only if COMP is OFF for 3 minutes or more.

12.5.6 Base Heater Setting

The base heater will be working only when RV is “ON” according to the following graph:

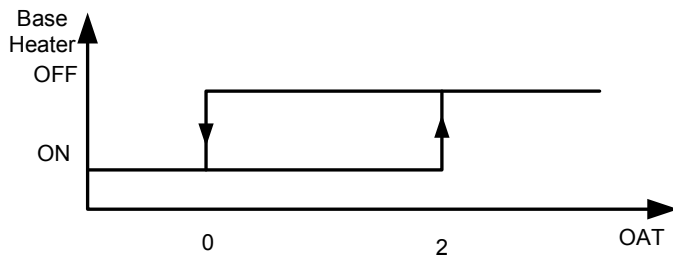

When OAT is faulty the base heater will be “ON” continuously in HEAT mode.

12.5.7 Crank case heater Operation

The crank case heater operates only when compressor is off and according to CTT as following:

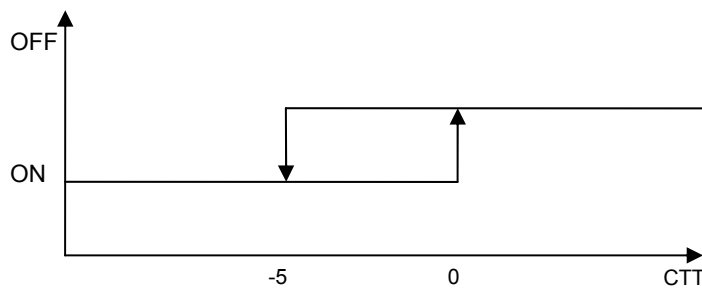

12.5.8 Compressor internal heating coil Operation

Only in 6HP unit.

The crank case heater operates only when compressor is off and according to CTT and OAT.

12.5.9 Thermodynamic Protections

12.5.9.1 Protection level definition

Five protection levels are defined:

Normal – No protection status.

Stop-Rise (SR) – Compressor not allowed raise speed.

D1 - Compressor speed reduced.

D2 - Compressor speed reduced rapidly.

Stop-Compressor (SC) – Compressor stops.

12.5.9.2 IDU Protections

ICT Value		ICT Trend				
Indoor Coil Defrost Protection	Indoor Coil Over Heating Protection	Fast Increasing	Increasing	No change	Decreasing	Fast Decreasing
ICT < -2	ICT > 62	SC	SC	SC	SC	SC
-2 ≤ ICT < 0	60 < ICT ≤ 62	D1	D1	D2	D2	D2
0 ≤ ICT < 2	55 < ICT ≤ 60	SR	SR	D1	D2	D2
2 ≤ ICT < 4	53 < ICT ≤ 55	SR	SR	SR	D1	D2
4 ≤ ICT < 6	51 < ICT ≤ 53	Normal	Normal	SR	SR	D1
6 ≤ ICT < 8	49 < ICT ≤ 51	Normal	Normal	Normal	SR	SR
8 ≤ ICT	ICT ≤ 49	Normal				

Operation logic of all protections is the same. The controlled input (CTT, HST, ACC, DCC) is controlled by changing the protection level using the fuzzy logic algorithm according the input level and the change rate.

The following table summarizes the basic levels of each protection:

Protection level	Compressor Overheat (CTT)	Compressor AC Over current (ACC)	Compressor DC Over current (DCC)	Heat Sink (HST)
SC	95	25.0	22.0	90
D2	92	24.6	21.4	87
D1	90	24.2	20.8	85
SR	87	23.6	20.0	83
Normal				78

There are two sets of ACC values, the selection of the values are set according to the state of the Power-Shed dry contact input.

Power-Shed input open ACC

Power-Shed input short PSOC

12.5.9.3 Total Protection Level Definition

The total protection level is defined by the higher level of protection received.

12.5.10 Deicing

12.5.10.1 Deicing Starting Conditions

Deicing operation will start when either one of the following conditions exist:

Case 1: OCT is 8 degree lower then the ambient temp and the minimum time from the last deicer is passed.

Case 2: OCT is 12 degree lower then the ambient temp and 30 minutes from the last deicer wa passed.

OCT – Outdoor Coil Temperature

Deicing interval time when compressor is first started in heat mode, is 10 minutes if OCT < -2, and is 40 minutes in other cases.

Deicing interval time is changed (increased/ decreased in 10 minutes steps) as a function of deicing time.

In case one of the thermistors is bad the deicer will initiate in predefined intervals

Deicer may accure also when the unit switch to stanby and the OCT is 8 degree lower then ambient temperature.

12.5.10.2 Deicing Protection Procedure

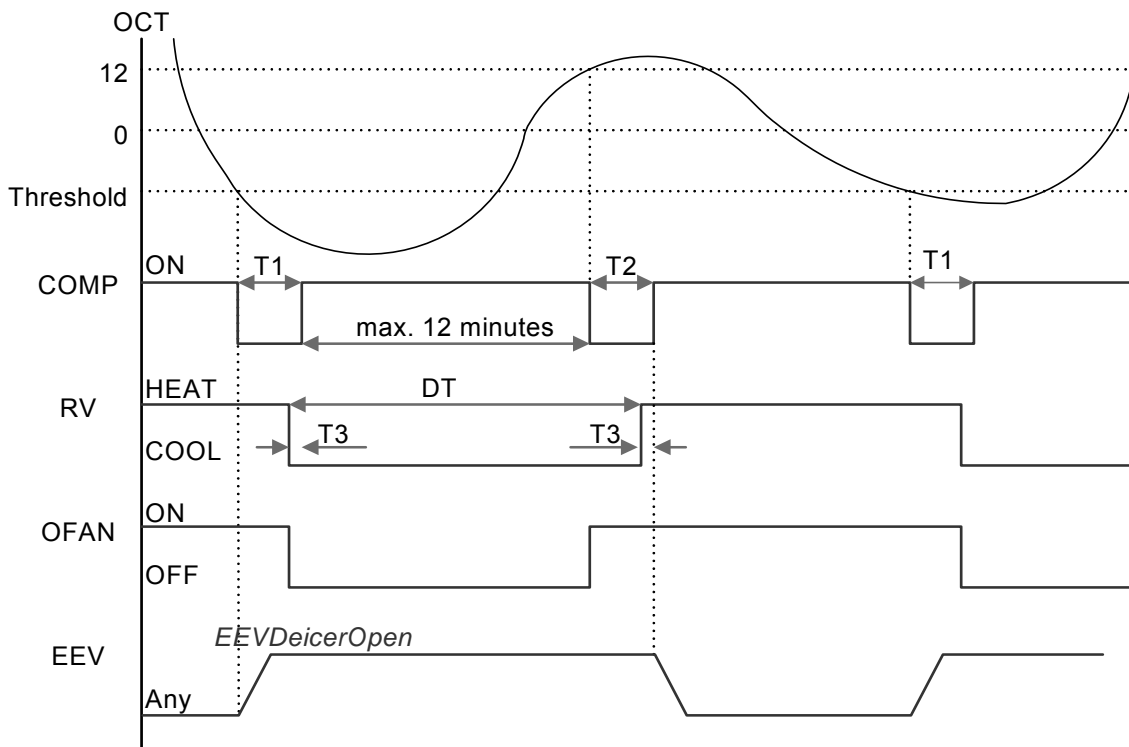

T1 = T2 = 36 seconds, T3 = 6 seconds

12.5.11 Condensate Water over Flow Protection

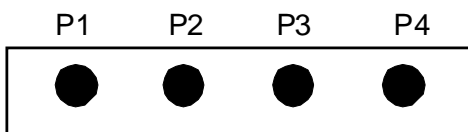

Each of the pins P1, P2, P3 can have two options:

1 – When it is shorted with P4

0 – When it is not shorted to P4

12.5.11.1 1 Level Logic

P2	P3	Level
Don't care	1	Normal
Don't care	0	Overflow

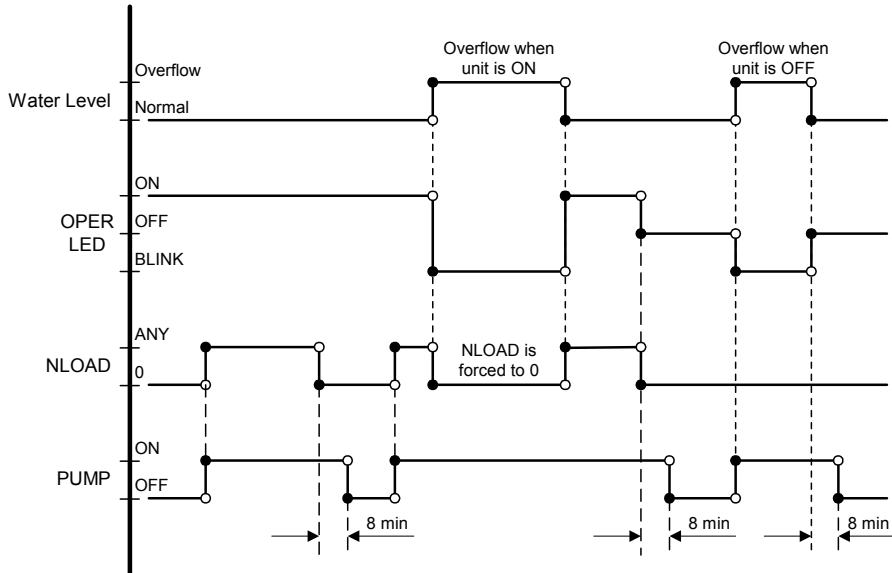

12.5.12 High/Low Pressure Protection

Whenever high or low pressure occurs in the system which extend beyond the system pre-defined limits, the high and low pressure switches turn on (short) and stop the compressor until these limits are redrawn.

Fault code error 28 (HPS) or 29 (LPS) will be shown until the compressor resumes operation.

12.6 Technician Test Mode

This test is aimed for technicians to check the system under a preset compressor and outdoor fan values while the expansion valves will function according to the normal running mode.

12.6.1 Entering technician mode

- This mode is entered through the outdoor unit using the HMI (refer to user interface section).
- It can be selected either for cool or heat.
- Technician test is not possible to enter during deicer.

Exiting technician mode

Technician mode will be terminated either when:

- Escaping by the HMI (exit from the ttC or ttH menus)
- 60 minutes are passed from entering

12.6.2 Technician mode procedure

- Indoor unit will enter technician test at high indoor fan speed.
- The outdoor unit will be working normally (according to the run mode control logic) except the following changes:
 - The dry contacts inputs will be ignored.
 - Protections will be operative for stop compressor only.
 - The compressor and the outdoor fan will be working in target preset values according to the following table:

Technician Test			
Unit	Compressor Speed		OFAN speed
	Cool	Heat	
4HP	54	64	800
5HP	71	75	800
6HP	55	63	800

12.7 User Interface

12.7.1 User interface description

- The user interface uses four 7-segments, and 4 keys.
- The 4 keys are:
 - Scroll - used to scroll between options (up and down)
 - Select - use to select an option
 - Escape - Will go up one level in the menu
- The user interface concept is Tree menus.

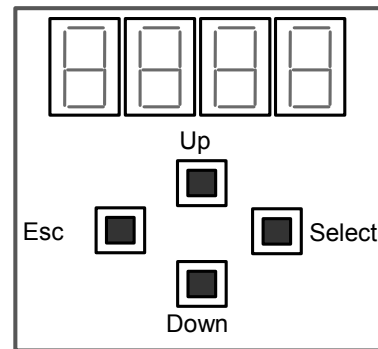

12.7.1.1 Status (Sub Menu)

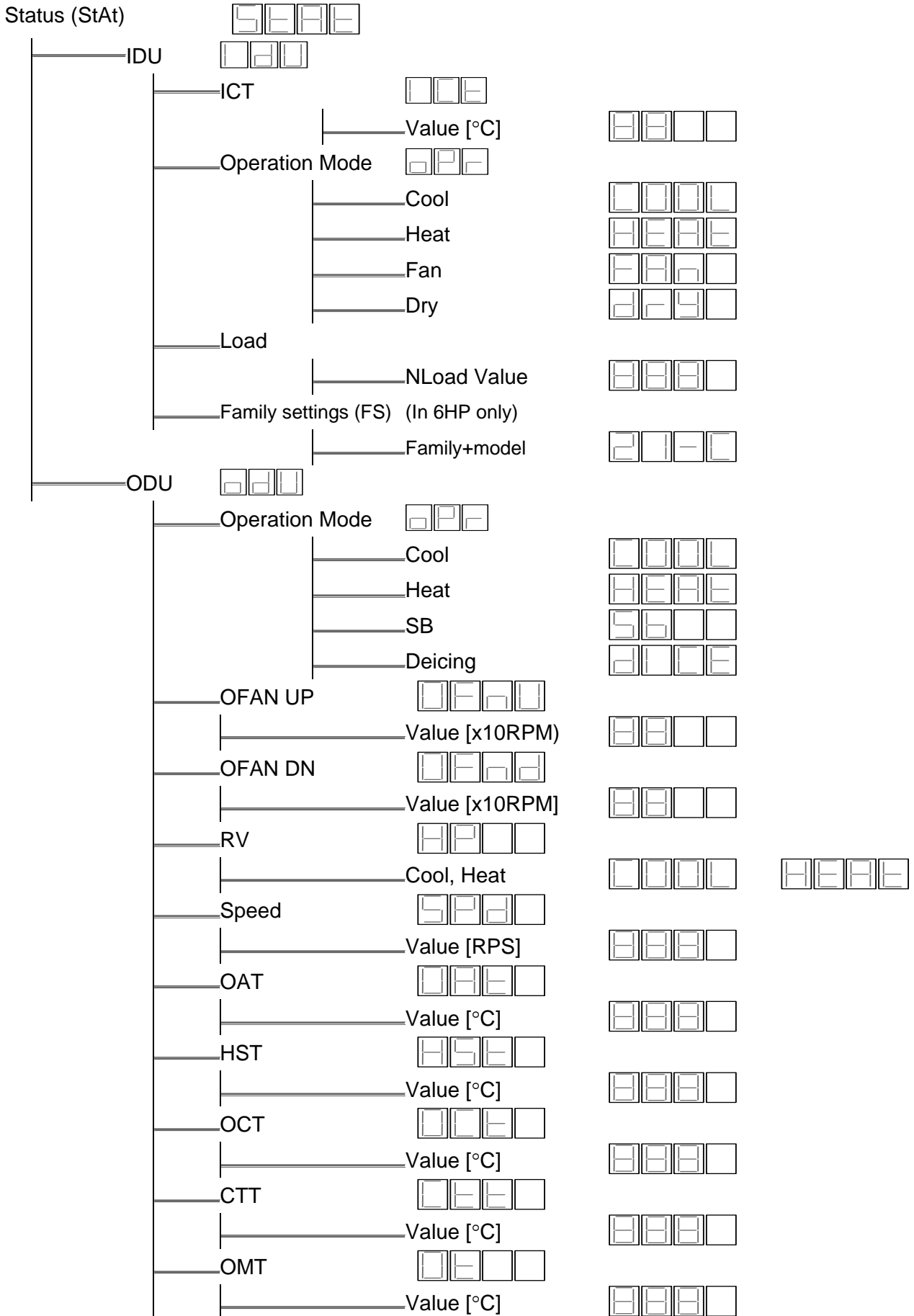

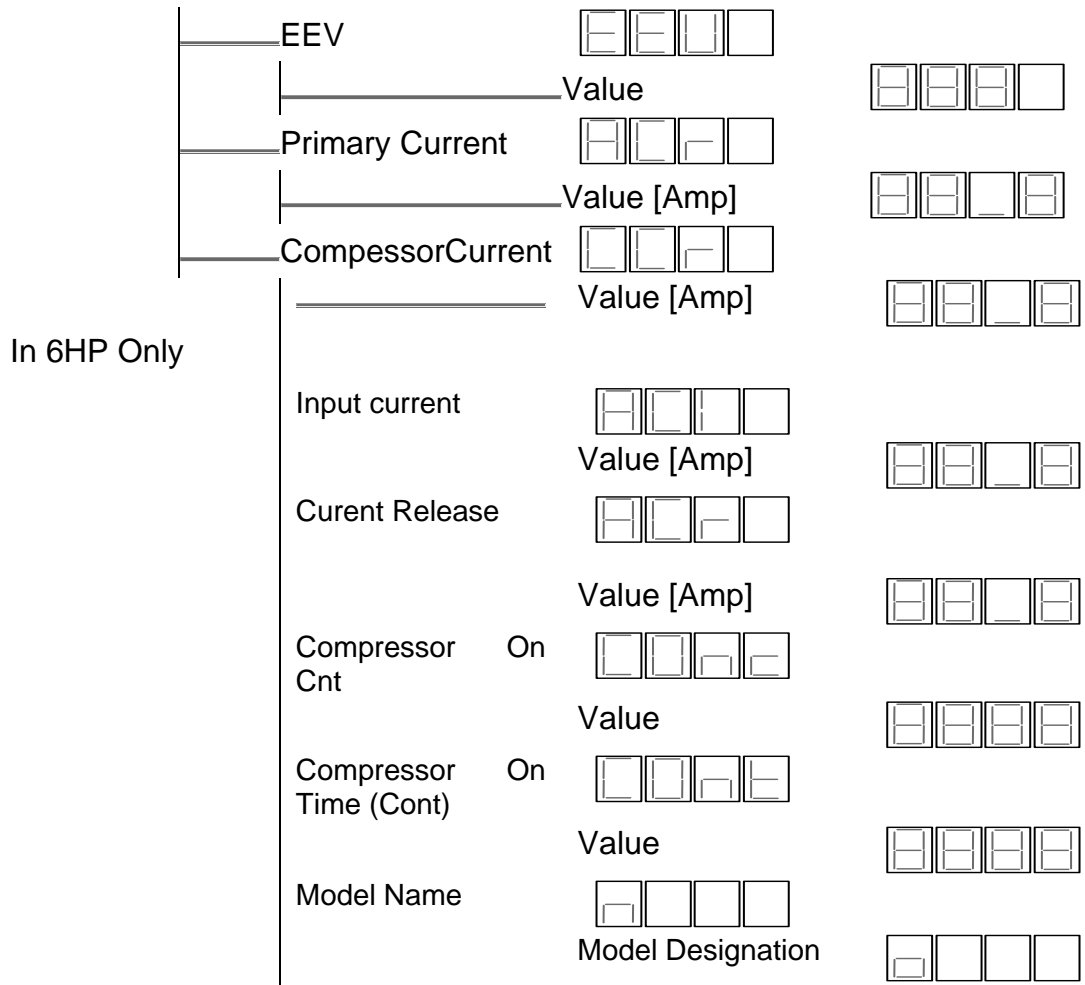

12.7.2 Menus

12.7.2.1 Main Menu

Mode (Cl/Ht/Sb)		□□□□	HEHE	SE□□
Technician Test (tt)	□□□		EE□	EEH
	Technician Test Cool (ttC)		EE□	
	Technician Test Heat (ttH)		EEH	
Diagnostics (dia)	□□□			
	Outdoor Unit (OdU)	□□□□		
	First Fault code		□-□□	
	Second Fault code		□-□□	
	Third Fault code		□-□□	
	Forth Fault code		□-□□	
	Fifth Fault code		□-□□	
	Indoor Unit (IdU)	□□□□		
	First Fault code		□-□□	
	Second Fault code		□-□□	
	Third Fault code		□-□□	
	Forth Fault code		□-□□	
	Fifth Fault code		□-□□	
Set Up (Set)	SE□□			
	IDU power supply source (IdSU)	□□□□		
	Outdoor unit		□□□□	
	Indoor source		□□□□	
	Max Current Limit (curl)	□□□□		
	Limit 30 A		□□□□	
	Limit 27 A		□□□□	
	Limit 23 A		□□□□	
	Limit 18 A		□□□□	
	Limit 14 A		□□□□	
	Power shade current limit (PSC)			
	50% of max current		□□□□	
	60% of max current		□□□□	
	70% of max current		□□□□	
	80% of max current		□□□□	

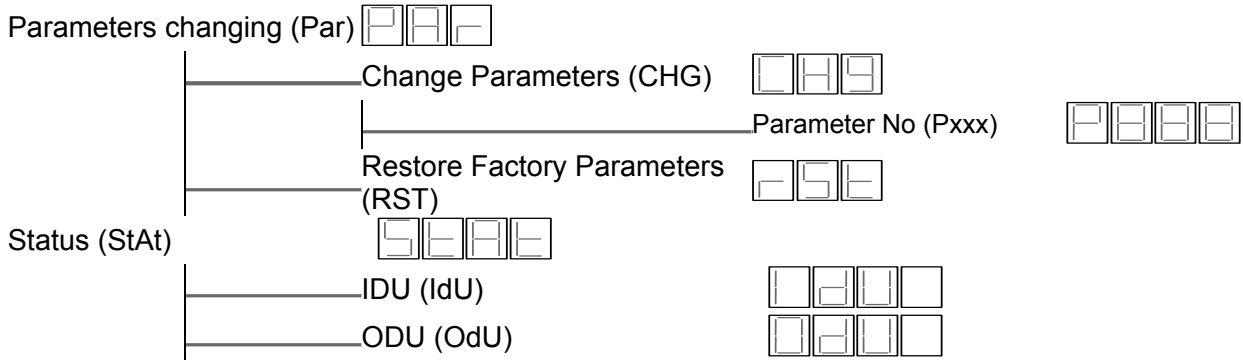

Notes:

1. The default presentation will be the mode of the unit (Cool/Heat/Stby).
2. In diagnostics menu:
 - xx means failure code two numbers.
 - Maximum 5 faults are presented for each unit (each IDUs/ODU). When no faults, a “----“ sign will be shown.
 - The active faults have higher priority for presentation than non active ones.
 - Active errors will blink on/off each sec.
 - Non active faults are presented according to their chronological order, starting from the latest one.
 - Whenever a new active fault occurs, it will be presented immediately.
3. The Parameters changing and Status menus (Technician menus) will be enabled to be presented and navigated, only by pressing select + escape together for more than 5 seconds under the main menu.
4. Exiting both ‘Parameters Changing’ and ‘Status’ menus and their sub-menus back to the main menu is done only by either pressing escape for more than 5 seconds or after continuous 10 minutes out of any press.
5. Technician Test mode is exited after 60 minutes from entry.
6. All the menus, except technician menus- Parameter changing, Status, Technician Test and their sub menus, are automatically exited to the main menu after 1 continuous minute out of any press.
7. When Technician test cool or heat menus are selected (operative), it will be blinking constantly until, this menu is escaped.
8. Pressing select and escape buttons together when in RST for more than 5 seconds will restore only the parameters of the factory settings. Acknowledge for restored parameters will be indicated by blinking RST for 3 seconds.
9. For the first 6 seconds after power is ON the display will show the current SW version. The display will show each 4 letters of the SW version at the time.

Example – SW Version 361V1-A01:

Will be displayed as:

361u	1A01
3sec	3sec

12.7.2.2 Parameter Change (Sub Menu)

- The parameters names will be indicated by the sequence 001, 002,...,999.
- When a parameter is selected, the parameter’s stored value is presented-aligned to the right.
- Scrolling changes the presented value, incrementing or decrementing, but does not store the value.
- Selecting a value, by pressing the selection key for 3 seconds, stores an updated value.

12.7.2.3 Status (Sub Menu)

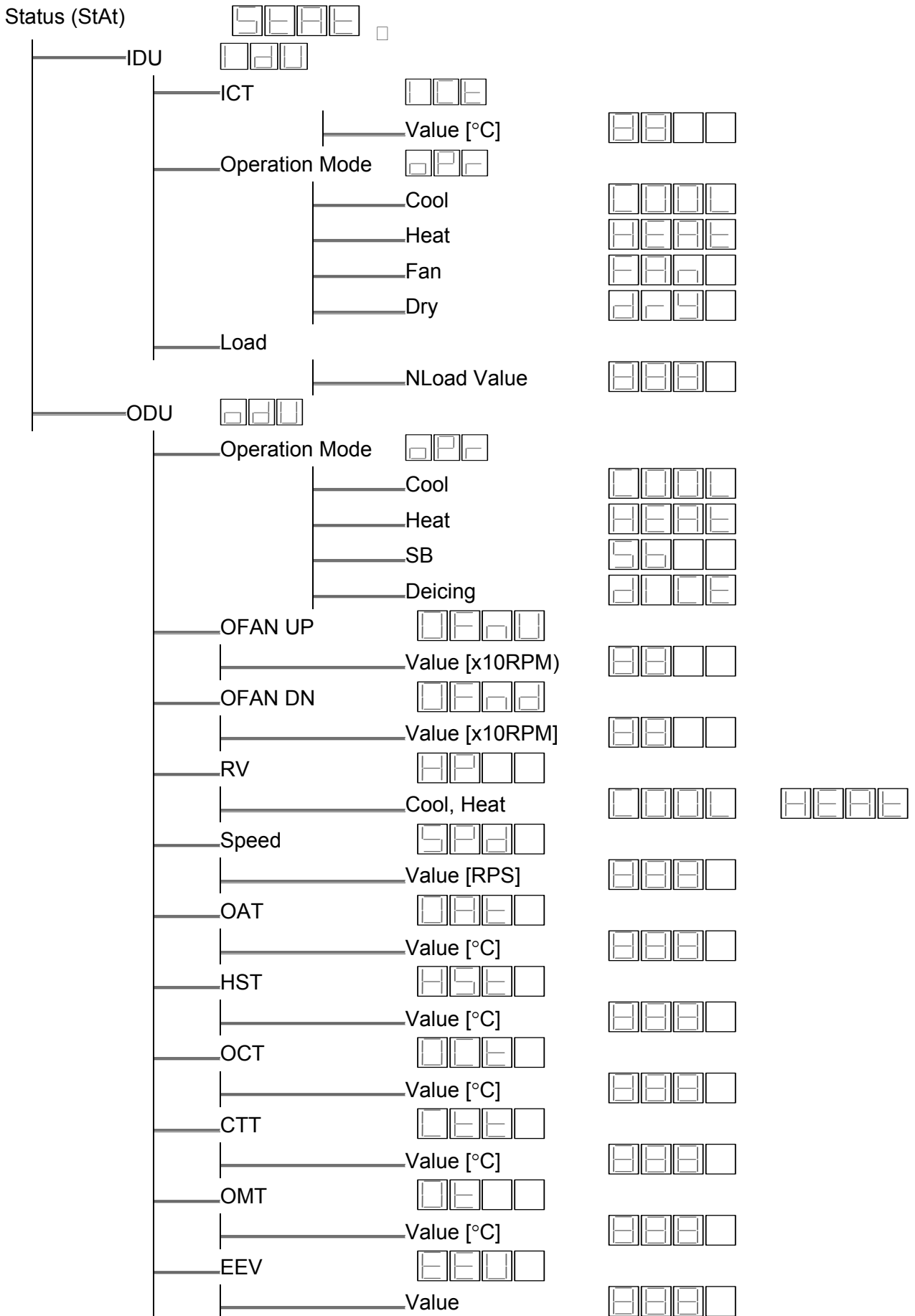

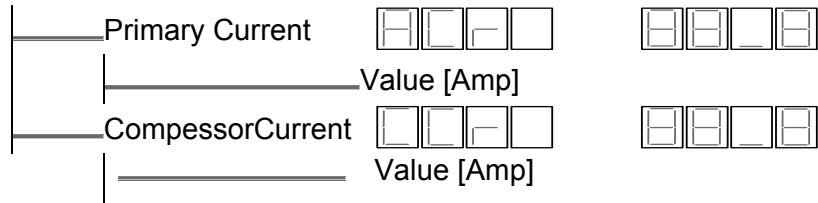

Notes:

- For the temperature display, when a thermistor is shorted or disconnected it shows FLT (FLt), when it is disabled it shows DIS (dis).
- It's possible to present a number between 999 and 99,999 by alternating between two numbers (each number is presented for 1 second). The two numbers format is "xx, yyy".
- Pressing select + escape together for 5 seconds will reset the counter to 0.
- The compressor time is measured in hours.

12.8 Jumper (DIP Switch) Setting

12.8.1. Jumper Definition

0 = Open (Disconnected)

1 = Close (Shorted)

12.8.2. IDU Jumpers



12.8.2.1. Self test Jumper/DIP – J1

Position	Status	Description
0	Open (Disconnected)	Normal Operation (Default)
1	Close (Shorted)	Self Test enabled

12.8.2.2. Compensation Jumper/DIP – J2

Position	Status	Description
0	Open (Disconnected)	Compensation deactivated
1	Close (Shorted)	Compensation activated (Default)

12.8.2.3. Family selection Jumper/DIP – J3, J4, J5

Family Name \ #	J3	J4	J5
DLS 36 / 43	1	1	0
DHC 36 / 43	0	1	0
CD 60	1	0	1

12.8.2.4. Model selection Jumper/DIP – J7, J8

Model	J7	J8
A – 36	0	0
B – 43	1	0
C – 60	0	1

12.8.2.5. Presence Detector/DIP – J9

Position	Status	Description
0	Open (Disconnected)	Presence detector enabled (Default)
1	Close (Shorted)	NA (Not to be used)

12.8.3. ODU Jumpers

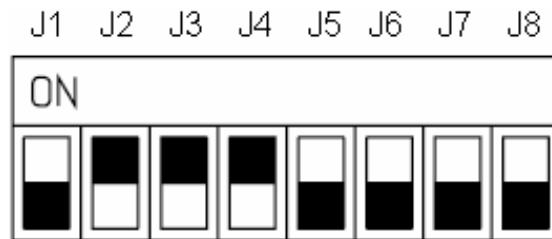

12.8.3.1. Self test Jumper/DIP – J1

Position	Status	Description
0	Open (Disconnected)	Normal Operation (Default)
1	Close (Shorted)	Self Test enabled

12.8.3.2. ODU Model Selection Jumper/DIP – J2, J3, J4, J5

ODU Model	J2	J3	J4	J5
M (GC 36)	ON	OFF	ON	ON
N (GC 43)	OFF	ON	ON	ON
O (GC 60)	ON	ON	ON	ON

12.8.4. Dip-Switch Setting table

GC

		1	2	3	4	5	6	7	8
GC 36	ON	White	Black	White	Black	Black	White	White	White
	OFF	Black	White	Black	White	White	Black	Black	Black
GC 43	ON	White	White	Black	Black	Black	White	White	White
	OFF	Black	Black	White	White	White	Black	Black	Black
GC 60	ON	White	Black	Black	Black	Black	White	White	White
	OFF	Black	White	White	White	White	Black	Black	Black

IDU

		1	2	3	4	5	7	8	9
DLS 36	ON	White	Black	Black	Black	White	White	White	White
	OFF	Black	White	White	White	Black	Black	Black	Black
DLS 43	ON	White	Black	Black	Black	White	Black	White	White
	OFF	Black	White	White	White	Black	White	Black	Black
DHC 36	ON	White	Black	White	Black	White	White	White	White
	OFF	Black	White	Black	White	Black	Black	Black	Black
DHC 43	ON	White	Black	White	Black	White	Black	White	White
	OFF	Black	White	Black	White	Black	White	Black	Black
CD 60	ON	White	Black	Black	White	Black	White	Black	White
	OFF	Black	White	White	Black	White	Black	White	Black

Note: in some cases where an external room thermostat kit is installed, the configuration of J2 in the indoor unit controller will be set to OFF.

12.9 System Parameters

12.9.1 General Parameters for All Models

12.9.1.1 GC 36 / 43

Name	Default Value	Units
<i>MinOFFTime</i>	3	minute
<i>MinONTime</i>	3	minute
<i>HzDown1</i>	3	Hz/min
<i>HzDown2</i>	10	Hz/min
<i>Dlmin</i>	30	minute
<i>Dlmax</i>	120	minute
<i>TimeD</i>	1	minute
<i>DTmin</i>	2	minute
<i>DTmax</i>	12	minute
<i>DIT</i>	10	minute
<i>CTMRUP</i>	15	minute
<i>DIF</i>	30	minute
<i>TCT</i>	10	second
<i>HSTOH1</i>	78	°C
<i>HSTOH2</i>	83	°C
<i>HSTOH3</i>	85	°C
<i>HSTOH4</i>	87	°C
<i>HSTOH5</i>	90	°C
<i>HSTOHDelta1</i>	-1	NA
<i>HSTOHDelta2</i>	1	NA
<i>EEVCVTConst</i>	15	second
<i>BalanceTime</i>	1	minute
<i>EEVInitOpen</i>	300	step
<i>DEICT1</i>	60	second
<i>DEICT2</i>	36	second
<i>DEICT3</i>	6	second
<i>EEVNormRate</i>	33	ms/pulse
<i>EEVHighRate</i>	12	ms/pulse
<i>EEVMaxOpen</i>	500	step
<i>DST</i>	8	°C
<i>DSTF</i>	12	°C
<i>DeiceFreqChRV</i>	0	Hz
<i>EEVDeiceTcnst</i>	20	second
<i>OFBIncTime</i>	2	minute
<i>OFTcnst</i>	60	second
<i>OFMinTimeReduce</i>	60	second

12.9.1.2 GC 60

Name	Default Value	Units
<i>MinOFFTime</i>	3	minute
<i>MinONTime</i>	3	minute
<i>HzDown1</i>	3	Hz/min
<i>HzDown2</i>	10	Hz/min
<i>Dlmin</i>	30	minute
<i>Dlmax</i>	120	minute
<i>TimeD</i>	1	minute
<i>DTmin</i>	2	minute
<i>DTmax</i>	12	minute
<i>DIT</i>	10	minute
<i>CTMRUP</i>	15	minute
<i>DIF</i>	30	minute
<i>TCT</i>	10	second
<i>HSTOH1</i>	88	°C
<i>HSTOH2</i>	93	°C
<i>HSTOH3</i>	95	°C
<i>HSTOH4</i>	97	°C
<i>HSTOH5</i>	100	°C
<i>HSTOHDelta1</i>	-1	NA
<i>HSTOHDelta2</i>	1	NA
<i>EEVConst</i>	15	second
<i>BalanceTime</i>	1	minute
<i>EEVInitOpen</i>	300	step
<i>DEICT1</i>	60	second
<i>DEICT2</i>	36	second
<i>DEICT3</i>	6	second
<i>EEVNormRate</i>	33	ms/pulse
<i>EEVHighRate</i>	12	ms/pulse
<i>EEVMaxOpen</i>	500	step
<i>DST</i>	8	°C
<i>DSTF</i>	12	°C
<i>DeiceFreqChRV</i>	0	Hz
<i>EEVDeiceTcnst</i>	20	second
<i>OFBlncTime</i>	2	minute
<i>OFTcnst</i>	60	second
<i>OFMinTimeReduce</i>	60	second

12.9.2 ODU Model Dependent Parameters

#	Name	M DCI112	N DCI140	O DCI160	Unit
1.	<i>MinFreqC</i>	25	25	20	Hz
2.	<i>MaxFreqC</i>	75	85	70	Hz
3.	<i>MinFreqH</i>	25	25	20	Hz
4.	<i>MaxFreqH</i>	90	100	75	Hz
5.	<i>Step1Freq</i>	40	40	40	Hz
6.	<i>Step2Freq</i>	90	90	90	Hz
7.	<i>Step3Freq</i>	120	120	120	Hz
8.	<i>NightRPM</i>	60	60	60	*10RPM
9.	<i>CTTOH1</i>	87	87	87	°C
10.	<i>CTTOH2</i>	90	90	90	°C
11.	<i>CTTOH3</i>	92	92	92	°C
12.	<i>CTTOH4</i>	95	95	95	°C
13.	<i>ACCOC1</i>	16.6	23.6	23.0	A
14.	<i>ACCOC2</i>	17.2	24.2	23.8	A
15.	<i>ACCOC3</i>	17.6	24.6	24.4	A
16.	<i>ACCOC4</i>	18.0	25.0	25.0	A
17.	<i>DCCOC1</i>	20.0	20.0	-	A
18.	<i>DCCOC2</i>	20.8	20.8	-	A
19.	<i>DCCOC3</i>	21.4	21.4	-	A
20.	<i>DCCOC4</i>	22.0	22.0	-	A
21.	<i>EEVMinOperOpenC</i>	60	60	60	step
22.	<i>EEVMaxOperOpenC</i>	400	400	480	step
23.	<i>EEVMinOperOpenH</i>	60	60	60	step
24.	<i>EEVMaxOperOpenH</i>	480	480	480	step
25.	<i>OATLimitC</i>	25	25	25	°C
26.	<i>OATLimit1H</i>	4	4	4	°C
27.	<i>OATLimit2H</i>	15	15	15	°C
28.	<i>MaxFreqAsOATC</i>	70	70	60	Hz
29.	<i>MaxFreqAsOAT1H</i>	90	90	80	Hz
30.	<i>MaxFreqAsOAT2H</i>	60	60	60	Hz
31.	<i>NormAccel</i>	1	1	1	Hz/s
32.	<i>NormDecel</i>	1	1	1	Hz/s
33.	<i>OCTExitDeicer</i>	12	12	12	°C
34.	<i>MaxDeicerTime</i>	12	12	12	minute
35.	<i>DryContactDis</i>	1	1	1	Byte
36.	<i>NightRPS</i>	60	60	55	RPS

12.9.3 Indoor Units SW Parameters

Parameters defining the indoor fan speed as a function of Indoor Coil temperature in heat mode (ICT):

12.9.3.1 Parameters for defrost protection:

ICTST Speed	ICT to stop indoor fan	25
ICTVLSpeed	ICT to go down to very low speed	28
ICTLSpeed	ICT to start in very low speed	30
ICTHSpeed	ICT to start in increase speed from very low	32
ICTTSpeed	ICT to enable Turbo fan speed	40
ICTDef1	ICT to go back to normal	8
ICTDef2	ICT to 'stop rise' when ICT decrease	6
ICTDef3	ICT to 'stop rise' when ICT is stable	4
ICTDef4	ICT to 'Hz Down' when ICT decrease	2
ICTDef5	ICT to 'Hz Down' when ICT is stable	0
ICTDef6	ICT to stop compressor	-2

12.9.3.2 Parameters for indoor coil over heating protection:

ICTOH1	ICT to go back to normal	49
ICTOH2	ICT to 'stop rise' when ICT increase	51
ICTOH3	ICT to 'stop rise' when ICT is stable	53
ICTOH4	ICT to 'Hz Down' when ICT increase	55
ICTOH5	ICT to 'Hz Down' when ICT is stable	60
ICTOH6	ICT to stop compressor	62

13. TROUBLESHOOTING

13.1 Precaution, Advise and Notice Items

13.1.1 High voltage in Indoor and Outdoor unit electrical assembly

- Open the Outdoor unit controller assembly only after one minute from power off.
- Whole controller assembly, including the wires, connected to the Outdoor unit may have the potential hazard voltage when power is on.
- Touching the Outdoor unit controller assembly may cause an electrical shock.
- Do not touch the naked lead wire and don't insert finger, conductor or anything else into the controller when power is on.

13.1.2 Charged Capacitors

- Large capacity electrolytic capacitors are used in the outdoor unit controller and driver.
- Charging voltage (380VDC) remains after power is down.
- Discharging takes about one minute after turned off.
- Touching the outdoor unit electrical assembly before discharging may cause an electrical shock.
- Measure the electrolytic capacitors voltage to be below 50VDC before further checking electrical assembly parts.

13.1.3 Advisory Notes

- When open the Outdoor unit electrical assembly, don't touch the soldering pin by hand or by any conductive material.
- When connecting or disconnecting the connectors on the PCB, hold the whole housing, don't pull the wire.

WARNING!!!

- When Power Up – the outdoor and indoor unit electrical assemblies, including the wiring, are under HIGH VOLTAGE!!!
- Never open the outdoor or indoor units before turning off **ALL** Power sources!!!
- When turned off, the outdoor unit electrical assembly is still charged (400V)!!!
- DC capacitors are discharging for about 1 Minute after power is OFF.
- Touching the electrical before discharging may cause an electrical shock!!!
- **For safe handling of the electrical assembly please refer to section 13.1 above.**

13.2 General System Failures and Corrective Actions

No.	SYMPTOM / PROBLEM	PROBABLE CAUSE	CORRECTIVE ACTION
Indoor unit			
1.	Indoor unit power supply indicator (Red LED) does not light up.	No Power supply	Check supply voltage to main terminals L and N with volt meter.
		No supply from outdoor	Check fuse at the connection wiring on outdoor unit terminals (see Electrical Scheme 9.4)
		Miss-wiring	Check all supply wiring to controller and terminals according to wiring diagram
		Loose connection	Check all power wiring connections
		Display and display cable	Check continuity of each wire of the display wires/pins with Ohm meter
		If still not OK	Check if fuse burnt
2	Fuse burned in indoor unit controller	Short Circuit between wires	Check for any cuts or exposed supply wires or miss-wiring
		Failure of Indoor Unit Fan Motor	Check the motor and capacitor (13.5.19) Check for any cuts or exposed wires
		If still not OK	Replace fuse
3	Indoor unit does not respond to remote control message	Remote control message not reached the indoor unit	Check remote control batteries Check continuity of each wire of the display wires/pins with Ohm meter
		If still not OK	Replace display box or indoor Electronic Assembly (14.2.2, 14.2.3)
4	Indoor unit responds to remote control message but Operate indicator (Green LED) does not light up	Problem with display PCB	Replace display PCB (14.2.3).
		If still not OK	Replace indoor Electronic Assembly (14.2.2)
5	Indoor fan does not start (louvers are opened and Green LED is ON)	Unit in heat mode and coil is still not warm	Change to Cool or Fan mode
		Failure of Indoor Unit Fan Motor	Check the motor and capacitor (13.5.19) Check for any cuts or exposed wires
		Problem with controller or motor capacitor	Change to high speed and Check power supply to motor is higher than 220VAC
		If still not OK	Replace indoor Electronic Assembly (14.2.2)
6	Indoor fan works when unit is OFF, and indoor fan speed is not changed by remote control command.	Controller problem	Replace indoor Electronic Assembly (14.2.2)

No.	SYMPTOM / PROBLEM	PROBABLE CAUSE	CORRECTIVE ACTION
7	Water leakage from indoor unit	Indoor unit drainage tube is blocked	Check and open drainage tube
Outdoor unit			
8	Outdoor unit display board and leds are off	No power supply	Check supply voltage to main terminals L and N with volt meter.
		Miss-wiring	Check all supply wiring to controller and terminals according to wiring diagram
		Loose connection	Check all power wiring connections
		Burnt fuse	Check fuse on the main board (13.5.8)
		If still not OK	Replace main board (14.1.13)
9	Compressor does not start operation	One or some components are not operating well	Check for any fault code shown on display board and act accordingly (13.4)
		Electronics control problem or protection	
		PFC Chock coil	Check the PFC Chock coil (13.5.6)
		Driver failure	Check if fault code #11, 18, 19 or 26 is shown on display board. If so, fix the problem according to (13.5.5) or replace driver (14.1.15).
		If still not OK	Replace compressor (14.1.10)

No.	SYMPTOM / PROBLEM	PROBABLE CAUSE	CORRECTIVE ACTION
10	Cooling capacity is not sufficient	Unit size not match the load	Check if the size chosen for the complete room(s) load is enough or need bigger units
		Piping size not matching system	Check if piping is installed correctly and proper diameter size and total length is according to unit specifications
		Refrigerant leakage	Check refrigeration system (13.3)
		Refrigerant over-charge	
		Refrigerant clog	Check and repair clogging specially near the EEV
		Electronics control problem or protection	Check for any fault code shown on display board and act accordingly (13.4)
		Compressor failure	Check if fault code #11 or 26 is shown on display board. If so, fix the problem according to (13.5.10) or replace driver
		Indoor coil block	Clean filters and/or remove block or air by-pass
		Indoor fan malfunction	Check the motor and capacitor (13.5.19)
		Overflow	Check if the overflow switch is ON. Replace faulty switch or correct drain piping.
		Outdoor coil block	Remove block and/or avoid air by-pass
		Outdoor fan malfunction	Check outdoor fan motors (13.5.9)
		Indoor fan malfunction	Check if the overflow switch is ON. Replace faulty switch or correct drain piping.
		EEV malfunction	Check EEV (13.5.12)
Thermistor(s) malfunction	Check if any of fault codes #1-10 is shown on display board. Replace faulty thermistors (14.1.11, 14.1.12)		
11	Heating capacity is not sufficient	Check all according to above cooling problem (11)	
		Reverse valve	Check reversing valve operation (13.5.11)
		Deicing not performed well (during low outdoors temperatures)	Check OCT and OAT thermistors fault codes (#1-2 and 7-8) Check OCT thermistor if connected well to pipe Check OAT thermistor if connected well Check the thermistors operation (13.5.13)

No.	SYMPTOM / PROBLEM	PROBABLE CAUSE	CORRECTIVE ACTION
12	Compressor is over heated	Electronic control	Check for any fault code shown on display board and act accordingly (13.4)
		EEV problem	Check EEV (13.5.12)
		Refrigerant leakage	Check refrigeration system (13.3)
		Indoor coil block	Clean filters and/or remove block
		Indoor fan malfunction	Check indoor fan motor and capacitor (13.5.19)
		Outdoor coil block	Remove block and/or avoid air by-pass
		Outdoor fan malfunction	Check outdoor fan motors (13.5.9)
		Compressor malfunction	Check the compressor (13.5.10)
13	Compressor stops many times during operation	Check all according to above problem (13)	
		HP Switch	Check if HPS fault code (#28) is accruing frequently. If so, check the switch operation (13.5.14)
		LP Switch	Check if LPS fault code (#29) is accruing frequently. If so, check the switch operation (13.5.15)
14	Unit is cooling while in heat mode	RV problem	Check RV operation (13.5.11)
		IDU-ODU communication	Check the communication between outdoor and indoor units (13.5.17)
15	Compressor is generating abnormal noise	Phase order to compressor is wrong	Check compressor phase order
		Compressor internal parts wearing	Replace compressor (14.1.10)
		Vibration	Check all piping connections Check compressor rubbers are fixed well Check all screws on unit metal chassis are tightened Check that no piping is in contact with each other or with other parts.
16	Freezing of outdoor unit coil in heat mode and outdoor unit base is blocked with ice		Connect base heater
17	The unit stop suddenly during operation	EMC interference to the A/C unit	Check for EMC problems (13.5.20.1)
18	Indoor unit Indicator leds may flicker		

No.	SYMPTOM / PROBLEM	PROBABLE CAUSE	CORRECTIVE ACTION
19.	Other home appliances operation is faulty such as noise appears in the television picture, or the picture is distorted or static occurs in the radio sound	EMC interference by the A/C unit	Check for EMC problems (13.5.20.2)
20.	All others	Specific problems of indoor or outdoor units	Check for any fault code shown on display board and act accordingly (13.4)

13.3 Checking the refrigeration system

Checking system pressures and other thermodynamic measures should be done when system is in technician Mode where the system operates as in fixed settings. The performance curves given in this manual are given for unit performance in Technician mode when high indoor fan speed is selected.

For entering technician mode see **12.6**.

13.4 Troubleshooting by Diagnostics Codes

13.4.1 Fault Code for Outdoor Unit

If any fault exists in the system, its fault will be shown according to the following coding method. The 5 last fault occurred in the system will be stored in the EEPROM.

If no fault exist in the system, no fault code will be displayed during normal operation mode. STATUS LED is blinking 5 times in 5 seconds, and shut off for the next 5 seconds.

FAULT LED will blink during the same 5 seconds according to the following table

The LED coding method is as follow:



No	Problem	5	4	3	2	1
1	OCT is disconnected	0	0	0	0	1
2	OCT is shorted	0	0	0	1	0
3	CTT is disconnected	0	0	0	1	1
4	CTT is shorted	0	0	1	0	0
5	HST is disconnected (when enabled)	0	0	1	0	1
6	HST is shorted (when enabled)	0	0	1	1	0
7	OAT is disconnected	0	0	1	1	1
8	OAT is shorted	0	1	0	0	0
9	OMT is disconnected	0	1	0	0	1
10	OMT is shorted	0	1	0	1	0
11	IPM Fault	0	1	0	1	1
12	Bad EEPROM	0	1	1	0	0
13	DC under voltage	0	1	1	0	1
14	DC over voltage	0	1	1	1	0
15	AC under voltage	0	1	1	1	1
16	IDU/ODU Communication mismatch	1	0	0	0	0
17	No Communication to IDU	1	0	0	0	1
18	No Communication to Driver	1	0	0	1	0
19	Current sensor Fault	1	0	0	1	1
20	Heat sink Over Heating	1	0	1	0	0
21	Deicing	1	0	1	0	1
22	Compressor Over Heating	1	0	1	1	0
23	Compressor Over Current	1	0	1	1	1
24	OFAN_UP error	1	1	0	0	0
25	OFAN_DN error	1	1	0	0	1
26	Compressor Lock	1	1	0	1	0
27	Bad Communication	1	1	0	1	1
28	High pressure protection	1	1	1	0	0
29	Low pressure protection	1	1	1	0	1
30	Reserved	1	1	1	1	0
31	Reserved	1	1	1	1	1

1 - ON, 0 - OFF

Only one code is shown. Order of priority is lower to the higher number. Diagnostics is continuously ON as long power is on.

13.4.2 Outdoor unit diagnostics and corrective actions

No	Fault Name	Fault Description	Corrective Action
1	OCT is disconnected	Thermistor not connected or damaged	Check Thermistor (13.5.13)
2	OCT is shorted		
3	CTT is disconnected		
4	CTT is shorted		
5	HST is disconnected (when enabled)		
6	HST is shorted (when enabled)		
7	OAT is disconnected		
8	OAT is shorted		
9	OMT is disconnected		
10	OMT is shorted		
11	IPM Fault	Over current / IPM malfunction	Check no obstruction to electrical box and outdoor coil air inlet. Check if the inrush wiring is connected and if the inrush circuitry is operating well (13.5.4) Check Compressor (13.5.10) Check Driver (13.5.5) Check Capacitors (13.5.7)
12	Bad EEPROM	EEPROM parameters are corrupted	Reset the power. If problem still exist replace PCB only when change is required parameters
13	DC under voltage	DC voltage is lower than limit	Check if input voltage lower than limit (198VAC), if not and the problem persists, replace driver. If voltage is low, recommend the customer to fix the power supply Check driver (13.5.5) Check DC capacitors (13.5.7)
14	DC over voltage	DC voltage exceeds its high -	Check if input voltage higher than limit (253VAC), if not and the problem persists, replace driver. If voltage is high, shut off the power and recommend the customer to fix the power supply
15	AC under voltage	AC input voltage is lower than limit	Check if input voltage lower than limit (198VAC), if not and the problem persists, replace driver. If voltage is low, recommend the customer to fix the power supply
16	IDU/ODU Communication mismatch	Mismatch between IDU and ODU models	Units are not designed to operate together as system. Check and replace the models installed.
17	No Communication to IDU	IDU-ODU communication	Check communication between indoor and outdoor units (13.5.17)

No	Fault Name	Fault Description	Corrective Action
18	No Communication to Driver	Driver fault	Check power supply to driver Check driver communication (13.5.16)
19	Current sensor Fault	Driver fault	Replace Compressor Driver
20	Heat sink Over Heating	Compressor stopped due to heat sink protection	Check that the airflow around the ODU is free and the fan is running free Check the screws connecting the driver to heat sink are tighten Check outdoor fan motors (13.5.9)
21	Deicing	During deicing procedure	Normally no action is required If the problem persists for more than twice on each hour, check for refrigerant leak and thermodynamic operation (13.3)
22	Compressor Over Heating	Compressor stopped due to over heat protection	Normally no action is required If the problem persists for more than twice on each hour, check for refrigerant leak and thermodynamic operation (13.3) Check the EEV (13.5.12) Check the Outdoor fans (13.5.9) Check the Indoor fans (13.5.19) Check the Compressor (13.5.10) Check the CTT Thermistor (13.5.13)
23	Compressor Over Current	Compressor stopped due to over current protection	Normally no action is required If the problem persists for more than twice on each hour, check for refrigerant leak or clog and thermodynamic operation (13.3) Check the EEV (13.5.12) Check the Outdoor fans (13.5.9) Check the Indoor fans (13.5.19) Check the Compressor (13.5.10)
24	OFAN_UP error	Outdoor fan(s) does not rotate	Check no obstruction to outdoor unit coil air path Check OFAN motor (13.5.9)
25	OFAN_DN error		
26	Compressor Lock	Compressor does not rotate	Check if the inrush wiring is connected and if the if the inrush circuitry is operating well (13.5.4) Check Compressor (13.5.10) Check driver (13.5.5) Check Zero-cross wiring from driver to Line Filter (6HP Only)
27	Bad Communication	Bad communication lines	Check communication between indoor and outdoor units (13.5.17)

No	Fault Name	Fault Description	Corrective Action
28	High pressure protection	Compressor stopped due to high pressure protection	Normally no action is required If the problem persists for more than twice on each hour, check for refrigerant clog. Check the switch operation (13.5.14) Check the EEV (13.5.12) Check the Outdoor fans (13.5.9) Check the Indoor fans (13.5.19) Check the Compressor (13.5.10)
29	Low pressure protection	Compressor stopped due to low pressure protection	Normally no action is required If the problem persists for more than twice on each hour, check for refrigerant leak. Check the switch operation (13.5.15) Check the EEV (13.5.12) Check the Outdoor fans (13.5.9) Check the Indoor fans (13.5.19) Check the Compressor (13.5.10) Check the CTT Thermistor (13.5.13)

13.4.3 Fault Code for Indoor unit

Note: Indoor unit diagnostics can be viewed by the outdoor unit display board (**13.4**).

The below procedure is for viewing the indoor unit codes via the indoor unit led display.

Pressing Mode button for more than 5 seconds will activate diagnostic mode by the acknowledgment of 3 short beeps and lighting of COOL and HEAT LED's.

When Indoor diagnostics is displayed, all four LED's (STBY, Operate, Filter, TMR) are on.

Entering diagnostics in STBY mode allows only viewing of status (fault-display).

In diagnostic mode, system problems / information will be indicated by blinking of Heat & Cool LED's.

The coding method will be as follows:

Heat led will blink 5 times in 5 seconds, and then will be shut off for the next 5 seconds. Cool Led will blink during the same 5 seconds according to the following table:

No	Fault Name	5	4	3	2	1
1	RT-1 is disconnected	0	0	0	0	1
2	RT-1 is shorted	0	0	0	1	0
3	RT-2 is disconnected	0	0	0	1	1
4	RT-2 is shorted	0	0	1	0	0
...	Reserved	0	0	1	0	1
7	Communication mismatch	0	0	1	1	1
8	No Communication	0	1	0	0	0
9	No Encoder	0	1	0	0	1
10	Reserved	0	1	0	1	0
11	Outdoor Unit Fault	0	1	0	1	1
...	Reserved					
17	Defrost protection	1	0	0	0	1
18	Deicing Protection	1	0	0	1	0
19	Outdoor Unit Protection	1	0	0	1	1
20	Indoor Coil HP Protection	1	0	1	0	0
21	Overflow Protection	1	0	1	0	1
...	Reserved					
24	EEPROM Not Updated	1	1	0	0	0
25	Bad EEPROM	1	1	0	0	1
26	Bad Communication	1	1	0	1	0
27	Using EEPROM data	1	1	0	1	1
28	Model A	1	1	1	0	0
29	Model B	1	1	1	0	1
30	Model C	1	1	1	1	0
31	Model D	1	1	1	1	1

1 - ON, 0 - OFF

Only one code is shown. Order of priority is lower to the higher number. Diagnostics is continuously ON as long power is on.

13.4.4 Indoor unit diagnostics and corrective actions

No.	Fault	Probable Cause	Corrective Action
1-4	Sensor failures	Sensors not connected or damaged	Check Thermistor (13.5.13)
7	Communication mismatch	Mismatch between IDU and ODU models	Units are not designed to operate together as system. Check and replace the models installed.
8	No Communication	IDU-ODU communication	Check communication between indoor and outdoor units (13.5.17)
9	No Encoder	Indoor electronics or motor	Check motor wiring, if ok, replace motor
		If still not ok	replace Indoor electronic assembly (14.2.2)
11	Outdoor Unit Fault	Outdoor controller problem	Check for any fault code shown on outdoor unit display board and act accordingly (13.4)
17-18	Protections	Indication	No action

No.	Fault	Probable Cause	Corrective Action
19	Outdoor Unit Protection	Compressor stopped due to outdoor unit protection	Normally no action is required If the problem persists for more than twice on each hour, Check for any fault code shown on outdoor unit display board and act accordingly (13.4) Check the EEV (13.5.12) Check the Outdoor fans (13.5.9) Check the Indoor fans (13.5.19) Check the Compressor (13.5.10) Check the CTT Thermistor (13.5.13)
20	Indoor Coil HP Protection	Compressor stopped due to high pressure (heating) protection	Normally no action is required If the problem persists for more than twice on each hour, check for refrigerant leak and thermodynamic operation (13.3) Check the EEV (13.5.12) Check the Outdoor fans (13.5.9) Check the Indoor fans (13.5.19) Check the Compressor (13.5.10) Check the CTT Thermistor (13.5.13)
21	Overflow Protection	Compressor stopped due to water level overflow protection	Check the drainage tube for any clog. Correct drain piping or float switch if needed. It is highly recommended to install a siphon into the unit drainage point.
24	EEPROM Not Updated	System is using ROM parameters and not EEPROM parameters	No action, unless special parameters are required for unit operation.
25	Bad EEPROM		No action, unless special parameters are required for unit operation.
26	Bad Communication	IDU-ODU communication	Check communication between indoor and outdoor units (13.5.17)
27	Using EEPROM data	No problem	
28	IDU model	Indoor unit model connected is shown: Model A - 4HP unit	No problem
29		Indoor unit model connected is shown: Model B - 5HP unit	
30		Indoor unit model connected is shown: Model C - 6HP unit	
31		Not applicable	

13.5 Procedures for checking Main Parts

13.5.1 Discharge DC Voltage

WARNING

High voltage!!!

Wait for DC voltage to be discharged before touching any part of the driver to avoid electric shock.

Check to ensure that DC voltage has reduced to below 50VDC, if not, keep waiting until it does.

13.5.2 Checking Line Mains Voltage

Confirm that the Mains voltage is between 198 and 253 VAC. If Mains voltage is out of this range, abnormal operation of the system is expected. If in range, check the Power (Circuit) Breaker and look for broken or loosed cable lugs or wiring mistakes.

13.5.3 Checking Line Filter Board

- 1) Check for any burn signs on the filter board and its coils and relays, replace if any.
- 2) Check voltage at the inlet and outlet of the line filter. If no output voltage, replace line filter.

Replacing line filter - (14.1.19)

13.5.4 Checking Inrush Circuitry

- 1) Check continuity of each wire on the inrush wiring cable – repair if needed.
- 2) Power ON the unit, check voltage between both of the inrush pins on the ODU main board – should be 0 at first and 12VDC after 1 minute. A click sound should also occur after 1 minute. If no voltage – replace ODU main Board.
- 3) While power is off check resistance between line input and line output in the filter board – should be 200Ω. Turn on the power and check again, after 1 minute (after the click should be 0Ω. If not, the resistor is burned - replace Line filter.
- 4) Disconnect the inrush connector (red) from the line filter controller and Connect 9V battery to pins 1 and 3 (Non-polarity). A click sound should occur. If not, the relay is burned - replace Line filter.

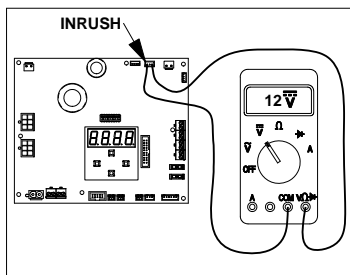

2) Inrush connector pin check

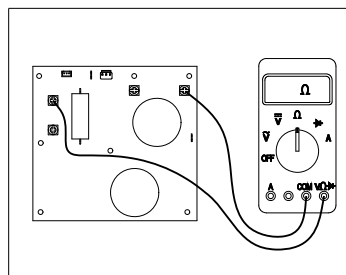

3) Inrush resistor check

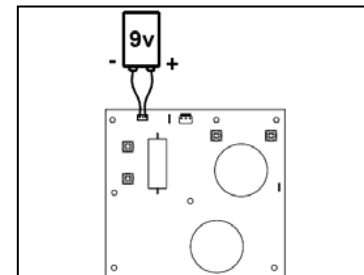

4) Inrush connector pin check

Replacing line filter - (14.1.19)

Replacing main board - (14.1.13)

13.5.5 Checking Compressor Driver

13.5.5.1 4-5HP

Remove all the terminals of the driver before checking.

If items 1) to 11) are performed and the results are satisfactory, driver is normal.

Use a digital multi meter in diode checking function

- 1) Connect the “VΩ” side of the tester to the “P1” terminal of driver and the “COM” side of the tester to “R” and “S” of driver, measure the diode voltage.

Voltage should be “OL” (Over Load).

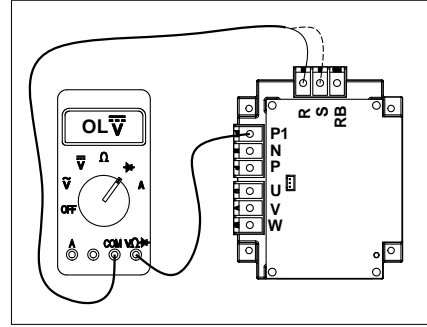

- 2) Connect the “COM” side of the tester to the “P1” terminal of driver and the “VΩ” side of the tester to “R” and “S” of driver, measure the diode voltage.

Voltage should be 0.4~0.8VDC.

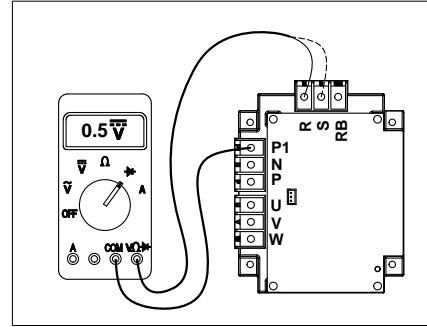

- 3) Connect the “COM” side of the tester to the “N” terminal of driver and the “VΩ” side of the tester to “R” and “S” of driver, measure the diode voltage.

Voltage should be “OL” (Over Load).

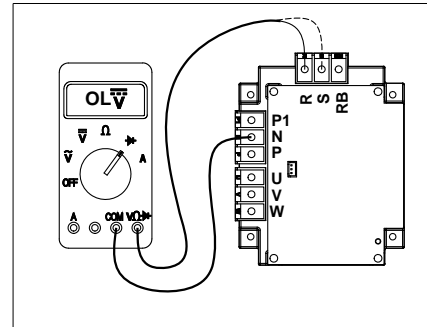

- 4) Connect the “VΩ” side of the tester to the “N” terminal of driver and the “COM” side of the tester to “R” and “S” of driver, measure the diode voltage.

Voltage should be 0.4~0.8VDC.

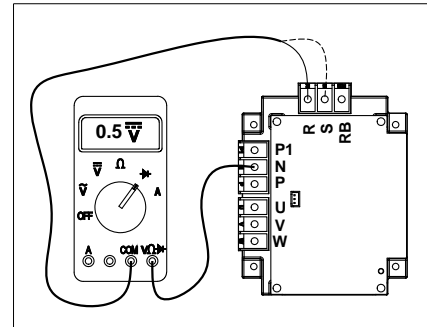

- 5) Connect the “COM” side of the tester to the “P” terminal of driver and the “VΩ” side of the tester to “U”, “V” and “W” of driver, measure the diode voltage.

Voltage should be 0.4~0.8VDC.

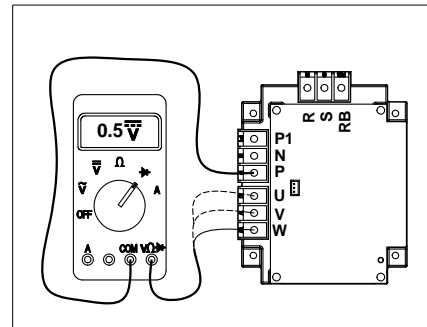

- 6) Connect the “VΩ” side of the tester to the “P” terminal of driver and the “COM” side of the tester to “U”, “V” and “W” of driver, measure the diode voltage.
Voltage should be “OL” (Over Load).

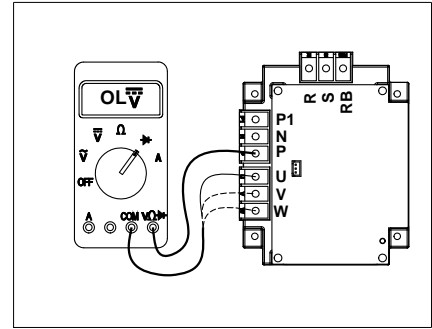

- 7) Connect the “COM” side of the tester to the “N” terminal of driver and the “VΩ” side of the tester to “U”, “V” and “W” of driver, measure the diode voltage.
Voltage should be “OL” (Over Load).

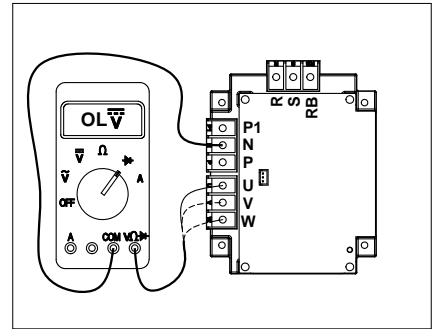

- 8) Connect the “VΩ” side of the tester to the “N” terminal of driver and the “COM” side of the tester to “U”, “V” and “W” of driver, measure the diode voltage.
Voltage should be 0.4~0.8VDC.

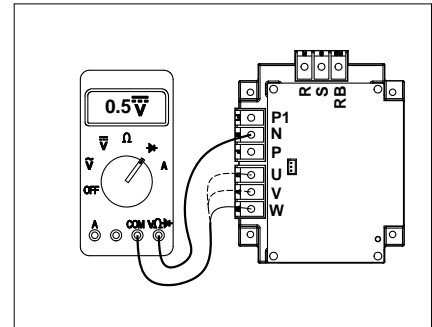

- 9) Connect the “COM” side of the tester to the “P” terminal of driver and the “VΩ” side of the tester to “T/RB” of driver, measure the diode voltage.
Voltage should be 0.3~0.8VDC.

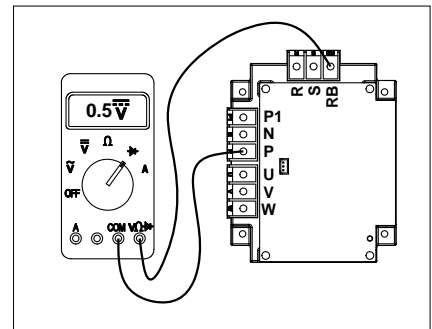

- 10) Connect the “VΩ” side of the tester to the “P” terminal of driver and the “COM” side of the tester to “T/RB” of driver, measure the diode voltage.
Voltage should be “OL” (Over Load).

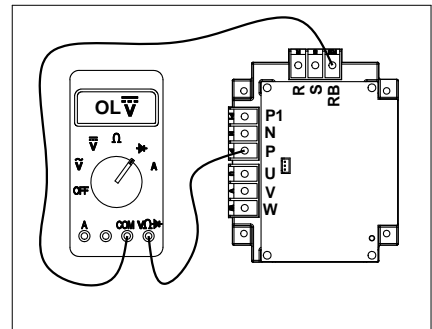

- 11) Connect the “COM” side of the tester to the “N” terminal of driver and the “VΩ” side of the tester to “T/RB” of driver, measure the diode voltage.
Voltage should be “OL” (Over Load).

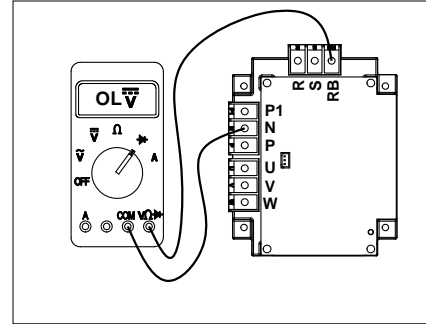

Replacing driver - (14.1.15)
13.5.5.2 GC 60

Remove all the terminals of the driver before checking.

If items 1) to 8) are performed and the results are satisfactory, driver is normal.

Use a digital multi meter in diode checking function

- 1) Connect the “COM” side of the tester to the “CAPA-” terminal of driver and the “VΩ” side of the tester to “LIVE” and “NEUTRAL” of driver, measure the diode voltage.
Voltage should be “OL” (Over Load).

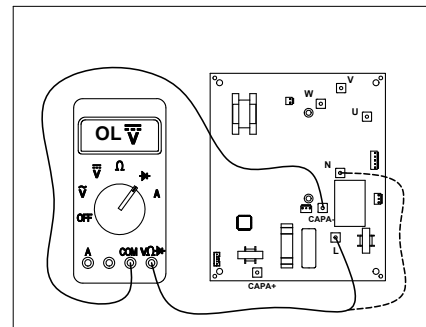

- 2) Connect the “VΩ” side of the tester to the “CAPA-” terminal of driver and the “COM” side of the tester to “LIVE” and “NEUTRAL” of driver, measure the diode voltage.
Voltage should be 0.4~0.8VDC.

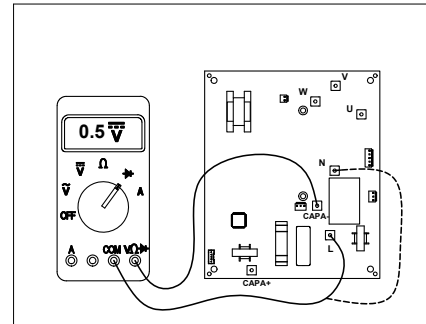

- 3) Connect the “COM” side of the tester to the “CAPA+” terminal of driver and the “VΩ” side of the tester to “LIVE” and “NEUTRAL” of driver, measure the diode voltage.
Voltage should be 0.4~0.8VDC.

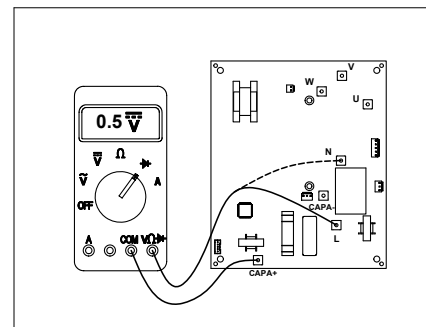

- 4) Connect the “VΩ” side of the tester to the “CAPA+” terminal of driver and the “COM” side of the tester to “LIVE” and “NEUTRAL” of driver, measure the diode voltage.
Voltage should be “OL” (Over Load).

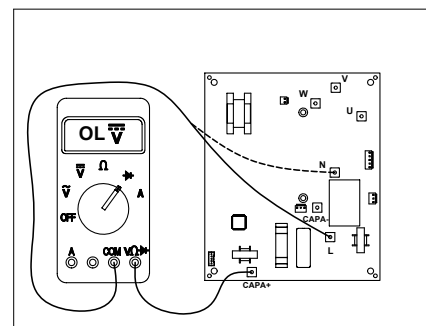

- 5) Connect the “COM” side of the tester to the “CAPA+” terminal of driver and the “VΩ” side of the tester to “U”, “V” and “W” of driver, measure the diode voltage. Voltage should be 0.4~0.8VDC.

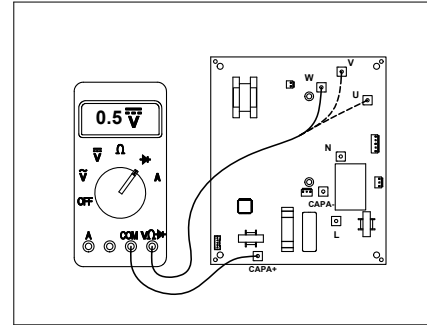

- 6) Connect the “VΩ” side of the tester to the “CAPA+” terminal of driver and the “COM” side of the tester to “U”, “V” and “W” of driver, measure the diode voltage. Voltage should be “OL” (Over Load).

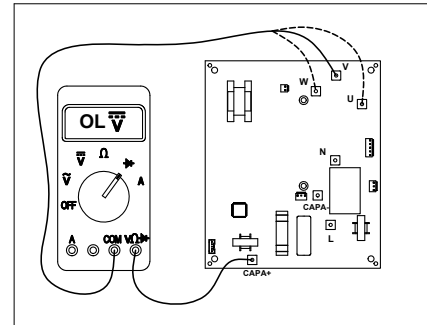

- 7) Connect the “COM” side of the tester to the “CAPA-” terminal of driver and the “VΩ” side of the tester to “U”, “V” and “W” of driver, measure the diode voltage. Voltage should be “OL” (Over Load).

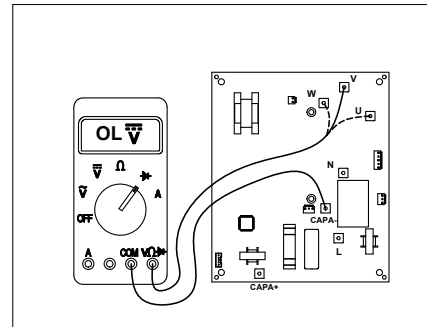

- 8) Connect the “VΩ” side of the tester to the “CAPA-” terminal of driver and the “COM” side of the tester to “U”, “V” and “W” of driver, measure the diode voltage. Voltage should be 0.4~0.8VDC.

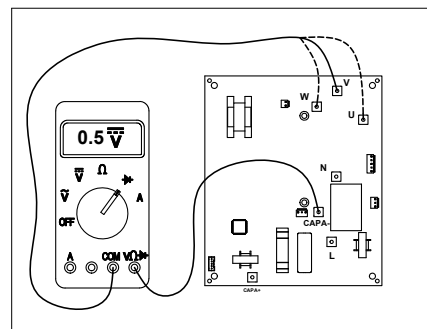

Replacing driver - (14.1.15.2)

13.5.6 Checking PFC Chock coil

- 1) Check PFC chock connections – repair if needed.
- 2) Visually check to see any burn marks on the wires – replace the chock(s) if needed.
- 3) Disconnect the chock from the driver and check if the 2 ending wires of each chock are shorted (continuity check) – if they are NOT shorted replace the chock(s), if they are shorted – check the driver (13.5.5).

Replacing PFC chock - (14.1.17)

13.5.7 Checking DC Capacitors

- 1) Check visually for burn marks on the capacitor PCB and the capacitors for swelling casing – replace if needed.

- 2) Check capacitance between the + and – poles, should be $2820 \pm 560 \mu\text{F}$ (4-5HP) or $4920 \pm 980 \mu\text{F}$ (6HP) – replace if not.

Replacing DC Capacitor board - (14.1.18)

13.5.8 Checking fuse on Main Board

If the 3.15A fuse on the main Board is burnt check the outdoor fans or any other peripheral that can cause a short:

- 1) In case of a problematic peripheral - replace it.
- 2) In case no problematic peripheral replace the burnt fuse.
- 3) In case of frequent burning fuse, replace the controller.

Replacing main board - (14.1.13)

13.5.9 Checking Outdoor Fan Motor

An Outdoor fan motor fault message may occur during very high winds outdoors that may stop the fan rotation for short periods. If so, need to relocate the outdoor unit to a more protected place from winds or install measure of air deflection in front of the fan outlets.

- 1) Check OFAN connections - Repair if needed.
- 2) Rotate the fan slowly by hand - If the fan does not rotate easily, check whether something is obstructing the fan preventing it from rotating – remove the obstruction if necessary. If no obstruction and still not operating - the fan motor bearings have seized - Replace the motor.
- 3) Disconnect the OFAN connector from the main board, switch ON the power and check the fan motor connector on the main board:
 - a. Between 1 and 3 – should be 310VDC. If very low or 0VDC, replace main board.
 - b. Between 3 and 4 – should be 15VDC. If very low or 0VDC, replace main board.
 - c. Between 3 and 6 – should be 15VDC. If very low or 0VDC, replace main board.
- 4) Connect back the motor connector to the main board, switch ON the power and check the motor current while operating. Current should be around 1A - In case of abnormal current (no current or excessive current), replace fan motor.

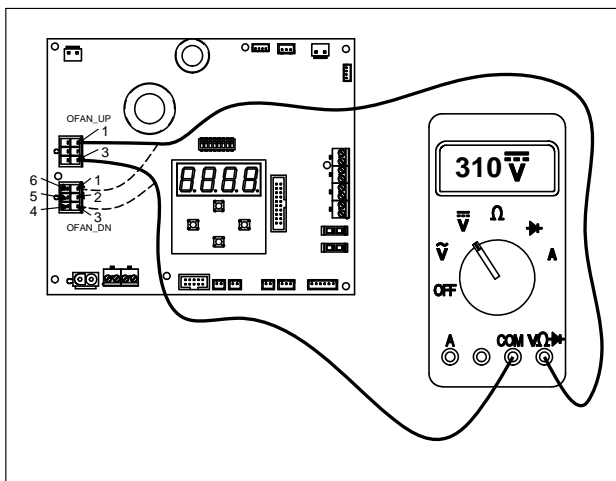

3)a Check motor current

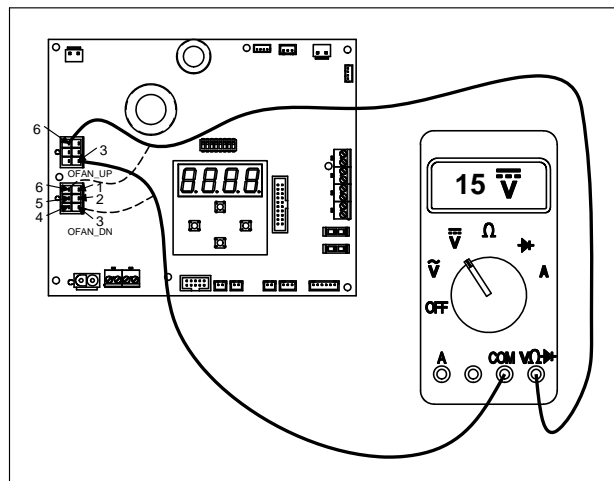

3)c Check motor current

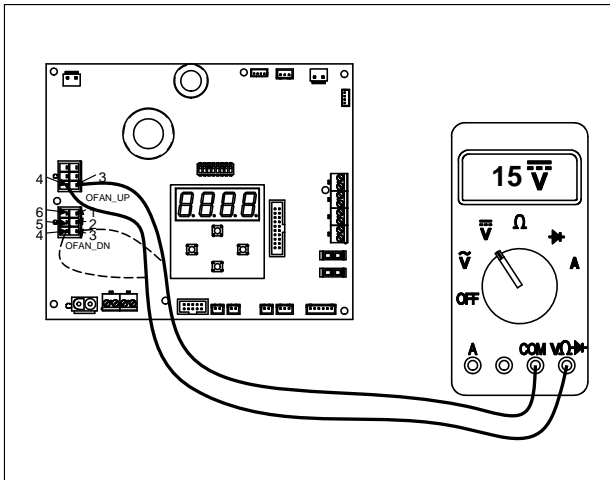

3)b Check motor current

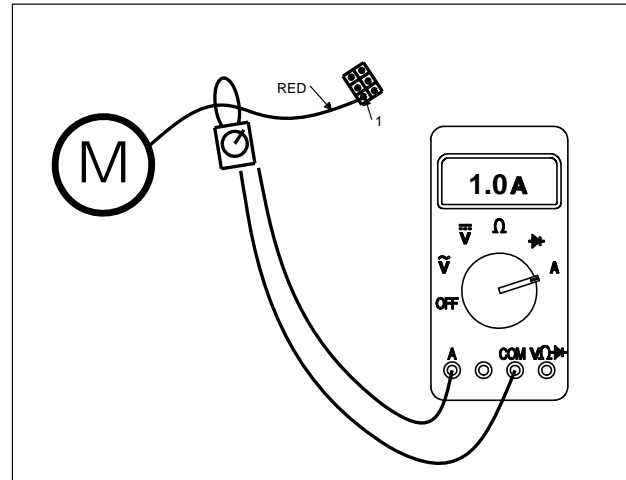

4) Check motor current

Replacing outdoor unit fan motor - (14.1.6)

Replacing main board - (14.1.13)

13.5.10 Checking Compressor

- 1) Check Compressor connections - Repair if needed.
- 2) Check the resistance between the three phases – all three coil resistances should be the same: around 0.188Ω .
- 3) Check the compressor current while operating to be the same on each wire - In case of abnormal current (no current or excessive current), the problem could be of driver or compressor – if driver is checked to be operating well (13.5.5), replace the compressor.

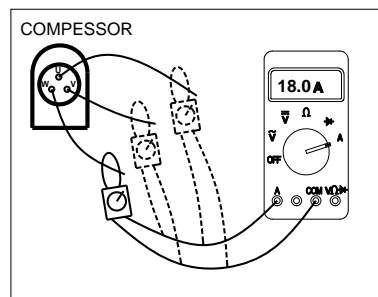

3) Check Compressor motor current

Replacing compressor- (14.1.10)

13.5.11 Checking Reverse Valve (RV)

The RV has two parts, Solenoid and valve.

- 1) Disconnect the RV connector from the main board and operate the unit in heating mode, check the voltage between two pins of reverse valve connector on the controller, normal voltage is 230VAC - if no power supply to RV, replace outdoor main board.
- 2) Check RV operation with direct 230VAC power supply. If RV solenoid is OK (but still no heating operation while compressor is ON), replace the RV valve from the refrigeration system. if not, replace the RV coil.

Replacing RV Coil (14.1.7)

Replacing RV Valve - (14.1.9)

Replacing main board - (14.1.13)

13.5.12 Checking Electrical Expansion Valve (EEV)

The EEV has two parts, step motor and valve. Use additional set of valve and coil to check the system.

- 1) Check the impedance in the coil wires to be as following:
 Grey wire to each of the other wires – about 100Ω
 Other wires – each one to the others (except grey) – about 50Ω
- 2) When Outdoor unit is powered on, EEV shall have vibration and click sound. If not, replace the coil with the additional one and check again – turn OFF the unit and than turn it ON, vibration and click sound should be performed. If OK, the coil was damaged and require to be replaced.
- 3) Turn OFF the unit, insert a good coil onto an additional operating valve and turn the unit ON, vibration and click sound should be performed. If OK, replace EEV valve from the unit.
- 4) If both EEV coil and valve are still not operating, replace the ODU main board.

Replacing EEV Valve Coil - (14.1.8)

Replacing EEV Valve - (14.1.9)

Replacing main board - (14.1.13)

13.5.13 Checking Thermistors

- 1) Check Thermistor connections and wiring - Replace if needed.
- 2) Check sensor visually - Replace if needed.
- 3) Check thermistor sensor attachment to pipe (or other parts), specially pay attention to the spring holding the sensor towards its sensing part – repair if needed.
- 4) Disconnect the connector from the main board and check Thermistor resistance – should be according the charts below for each sensor. If not in range of 10%, replace thermistor.
- 5) If thermistor resistance check is OK but reading is still wrong, replace main board.

OAT, OCT, OMT, ICT, RAT Chart

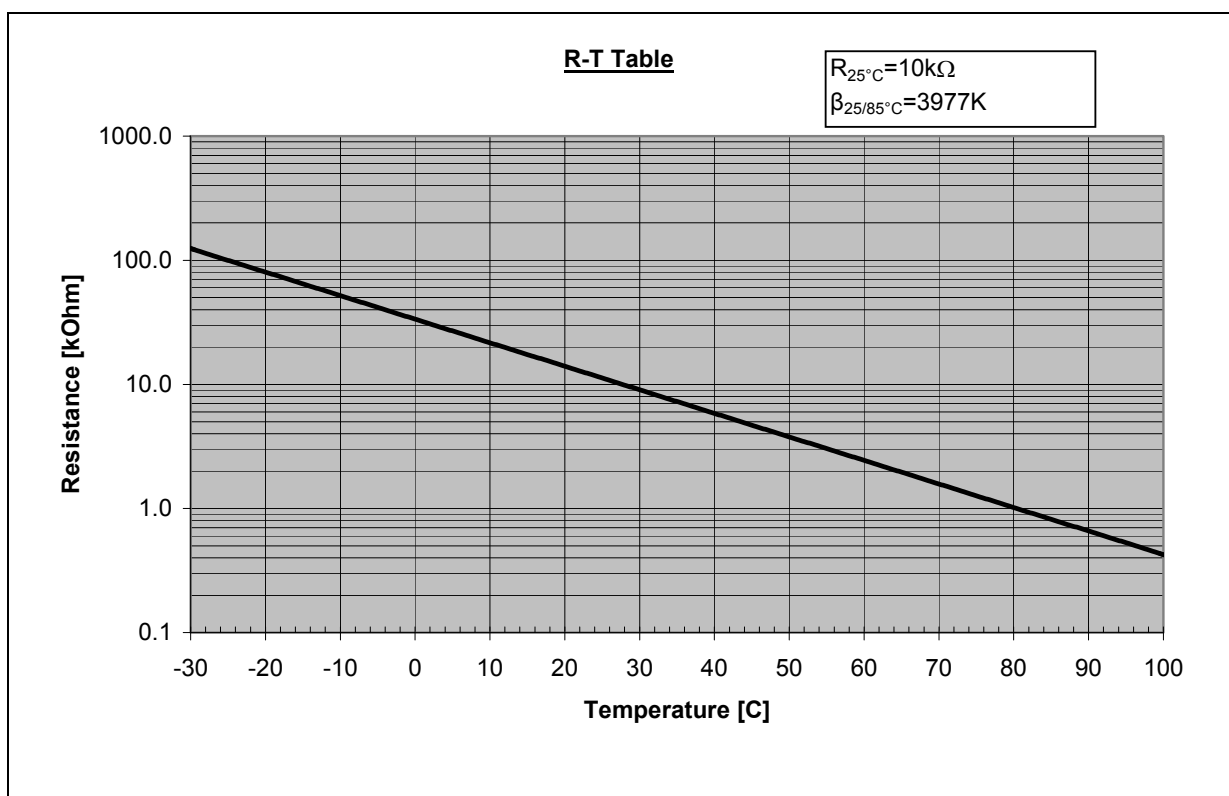

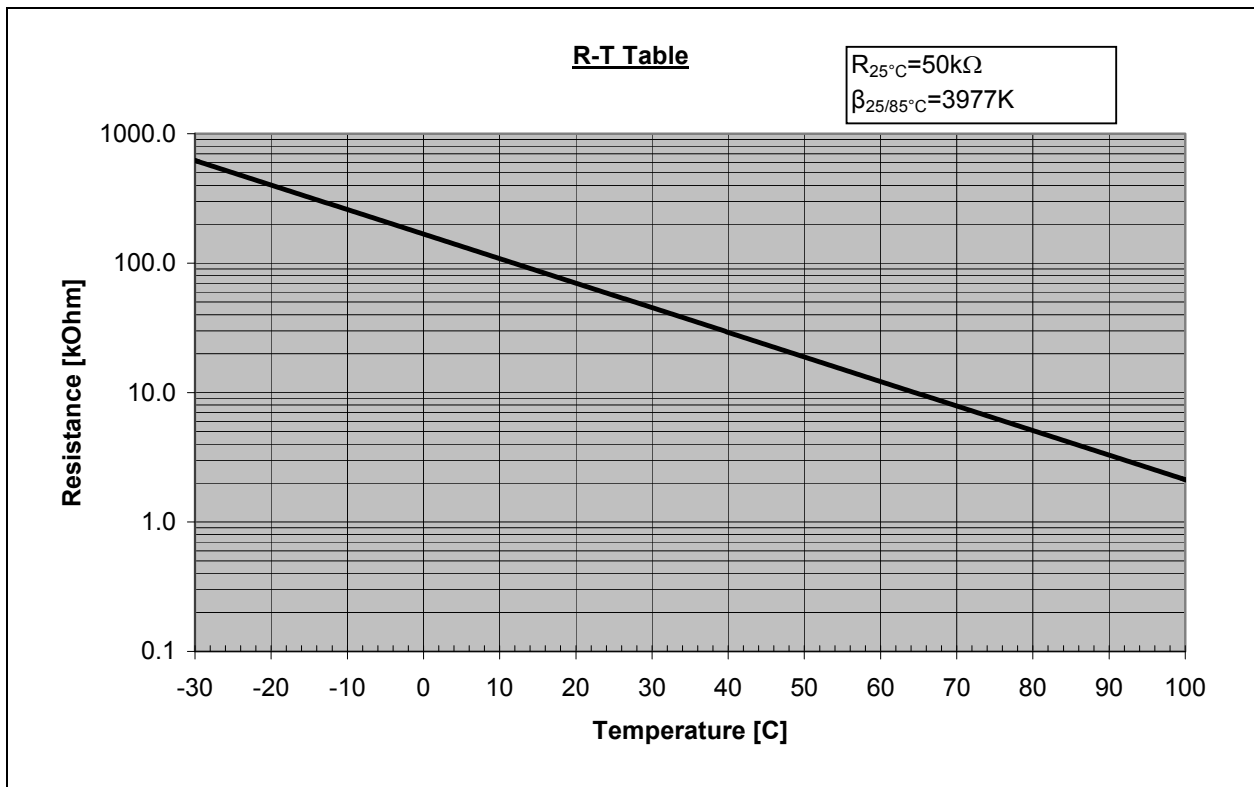
CTT Chart

Replacing thermistor - (**14.1.11, 14.1.12, 14.2.9**)

Replacing main board - (**14.1.13**)

13.5.14 Checking High Pressure Switch (HPS)

- 1) Disconnect HPS connector from the main board and check resistance between the 2 pins of the HPS connector – if shorted the HPS is OK, otherwise replace HPS.

Replacing HPS - (**14.1.9**)

13.5.15 Checking Low Pressure Switch (LPS)

- 1) Disconnect LPS connector from the main board and check resistance between the 2 pins of the HPS connector – if shorted the LPS is OK otherwise replace LPS.

Replacing LPS - (**14.1.9**)

13.5.16 Checking Compressor Driver Communications

- 1) Disconnect the wire cable from the connectors on both sides (driver and main board), check the wiring continuity – Repair or replace wiring if needed.
- 2) Turn power ON and check if the red led in the driver is lighted. If OK and still no communications, replace main board. If the led is OFF, replace driver.

Replacing Outdoor Unit main board - (**14.1.13**)

Replacing driver - (**14.1.15**)

13.5.17 Checking Indoor-Outdoor Unit Communications

- 1) Disconnect the wire cable from the connectors on both sides (main board and terminal block), check the wiring continuity – Repair or replace wiring if needed.
- 2) Check the continuity of the connecting wiring between indoor and outdoor units – Repair or replace wiring if needed.
- 3) Problem could be either in outdoor unit main board or indoor unit controller. To verify which one is faulty use additional boards and replace the one which is faulty.

Replacing Outdoor Unit main board - (14.1.13)

Replacing Indoor unit electrical assembly - (14.2.2)

13.5.18 Checking Indoor Unit Fuse on Controller

If the 3.15A fuse on the main Board is burnt check the fan or any other peripheral that can cause a short:

- 1) In case of a problematic peripheral - replace it.
- 2) In case no problematic peripheral replace the burnt fuse.
- 3) In case of frequent burning fuse, replace the controller.

Replacing Indoor unit electrical assembly - (14.2.2)

13.5.19 Checking Indoor Unit Fan Motor

- 1) Check the motor wiring from the controller.
- 2) Check the motor capacitor for capacitance according to the capacitor name plate.
- 3) Check the resistance between each coil of the motor to be within normal range (30-300Ω).
- 4) Check resistance between each wire to ground to be above 5Ω.

Replacing Indoor unit Fan Motor - (14.2.6)

Replacing Indoor unit electrical assembly - (14.2.2)

Replacing motor capacitor - (14.2.8)

13.5.20 Checking for electromagnetic interference (EMC problems)

13.5.20.1 EMC interference to the A/C unit

Locations most susceptible to interference

- 1) Locations near broadcast stations where there are strong electromagnetic waves.
- 2) Locations near amateur radio (short wave) stations.
- 3) Locations near electronic sewing machines and arc-welding machines.

Problem:

- 1) The unit may stop suddenly during operation.
- 2) Indicator lamps may flicker

Correction Actions:

The fundamental concept is to make the system less susceptible to noise by Insulation for noise or distance from the noise source.

- 1) Use shielded wires.
- 2) Move unit away from the noise source.

13.5.20.2 EMC interference to near by home appliances

Locations most susceptible to interference:

- 1) A television or radio is located near the A/C and A/C wiring.
- 2) The antenna cable for a television or radio is located close to the A/C and A/C wiring.
- 3) Locations where television and radio signals are weak.

Problem:

- 1) Noise appears in the television picture, or the picture is distorted.
- 2) Static occurs in the radio sound.

Correction Actions:

- 1) Select a separate power source.
- 2) Keep the A/C and A/C wiring at least 1 meter away from wireless devices and antenna cables.
- 3) Change the wireless device's antenna to a high sensitivity antenna.
- 4) Change the antenna cable to a BS coaxial cable.
- 5) Use a noise filter (for the wireless device).
- 6) Use a signal booster.

14. SERVICING

14.1 Outdoor Unit

WARNING

Note: To reassemble perform the procedures in reverse.

14.1.1 Removing Service (front) panel

Remove the 8 fixing screws and slide the service (front) panel downwards to remove it.

Note: Do not flip the panel forward on the top side as not to damage the controller.

14.1.2 Removing top panel

Remove the 8 fixing screws and take out the top cover.

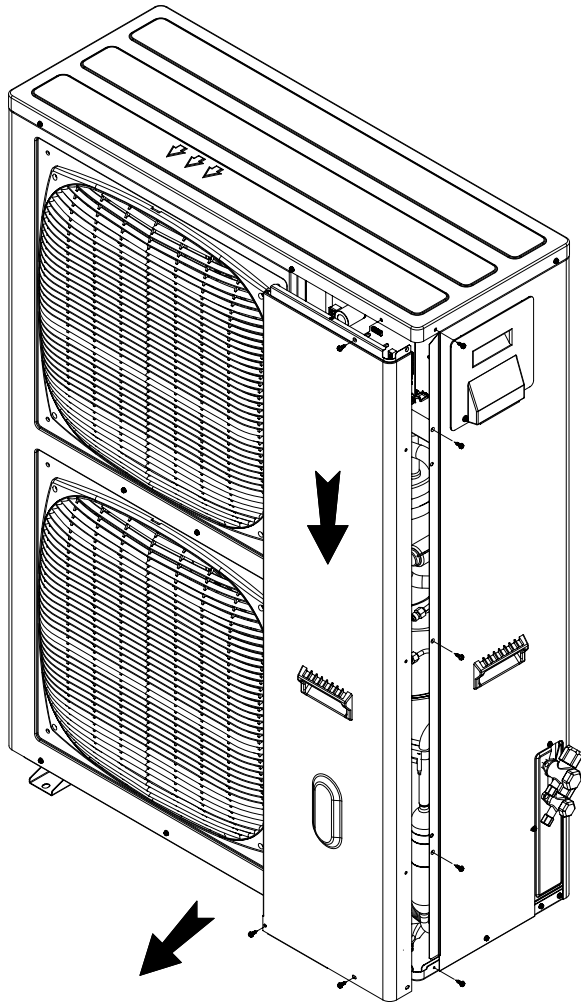

Removing Service (front) panel

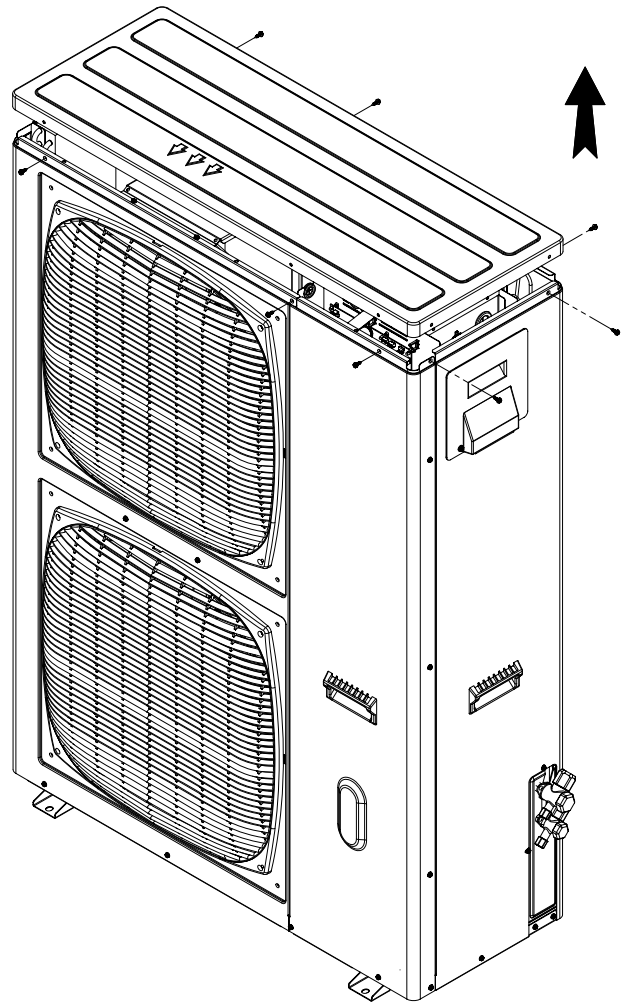

Removing Top panel

14.1.3 Removing side panel

1. Remove the top cover as in above **14.1.2**.
2. Remove the 2 screws holding the electrical plastic cover and disconnect the power supply cords.
3. Remove the 9 fixing screws and take out the side panel.

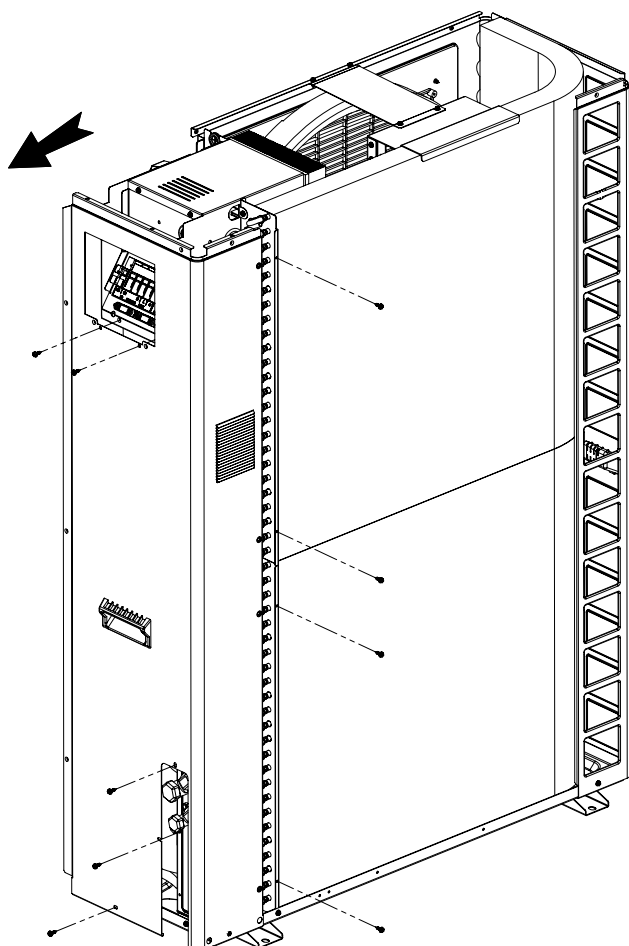

Removing side panel

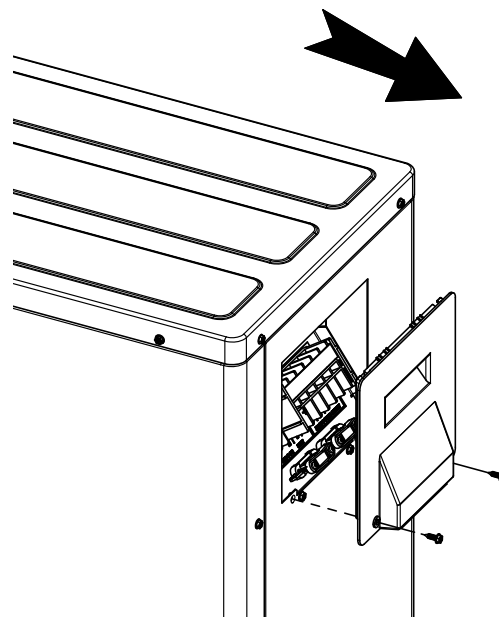

Removing Electrical Cover

14.1.4 Removing Air Outlet Grille(s)

Remove the 4 fixing screws of the each grille.

14.1.5 Removing Outdoor Fan

1. Remove the air outlet grille according to **14.1.4**.
2. Remove the hex nut from the motor shaft. To ease the removal, use rubber hammer to hit on the hex nut while pulling out the fan.

NOTES for re-assemble the fan:

1. Insert the skidding protection part of fan boss in accordance with the cutting part of the motor shaft. Push hard until fan can no longer be inserted.
2. Fix the screw after with tightening Torque of 8.0 Nm (80kg.cm)

14.1.6 Removing Outdoor Fan Motor

1. Remove the outdoor fan according to **14.1.5**.
2. Disconnect the motor connector from the main board.
3. Cut the nylon ties holding the motor cable.
4. Remove the four (4) fixing screws for the motor.

NOTES for re-assemble the motor:

1. When mounting the motor, ensure the cables point downwards.
2. Fix the protection tube edge downward to ensure the water may not keep in it.
3. Fix the motor wires with a nylon ties to prevent them obstructing the propeller fan.
4. When connecting the motor wire, check to ensure that the labels on the connectors match the PCB connectors.
5. Fix back the air outlet grille.

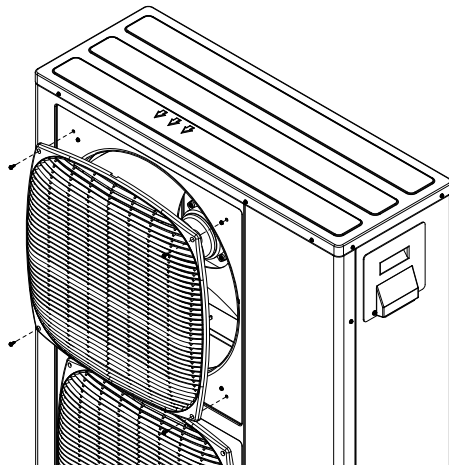

Removing Air Outlet Grille

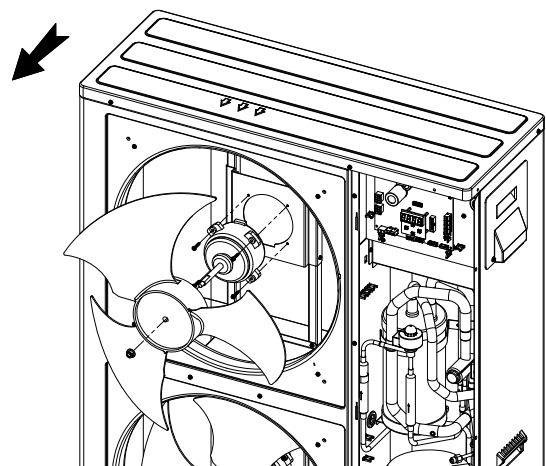

Removing Outdoor Fan & Motor

14.1.7 Removing Reversing Valve coil

1. Remove the service front panel according to **14.1.1**.
2. Check to ensure that LEDs and display board are OFF.
3. Disconnect the RV connector from the main board.
4. Remove the RV wires from the cable holders along the electronics box.
5. Remove the fixing screw from the reversing valve coil and take the coil out.

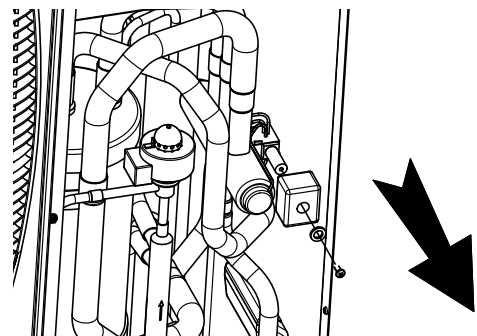

Removing Reversing Valve coil

14.1.8 Removing Expansion Valve coil

1. Remove the service front panel according to **14.1.1**.
2. Check to ensure that LEDs and display board are OFF.
3. Disconnect the EEV connector from the main board.
4. Remove the EEV wires from the cable holders along the electronics box.
5. Pull up the EEV coil.

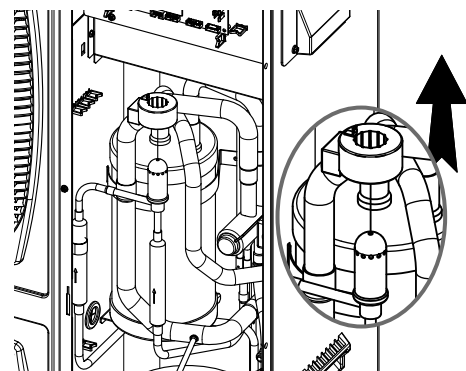

Removing Expansion Valve coil

14.1.9 Removing Refrigeration parts

Refrigeation parts: Expansion valve, Reversing valve, high pressure switch, etc.

1. Remove the refrigerant from the unit by a pumping machine via the 2 valves.

Note: *open the valves gradually and leave them only partially open for as long as the refrigerant exerts from the unit. Do not open the valves fully as not to loose any oil.*

2. Remove the service front panel according to **14.1.1**.
3. Check to ensure that LEDs and display board are OFF.
4. Remove the part connector from the main board.
5. Remove the part wires from the cable holders along the electronics box and or the partition.
6. Remove the part from its pipes using burner.

14.1.10 Removing Compressor

1. Remove the refrigerant from the unit by a pumping machine via the 2 valves.

Note: *open the valves gradually and leave them only partially open for as long as the refrigerant exerts from the unit. Do not open the valves fully as not to loose any oil.*

2. Remove the service front panel according to **4.1.1**.
3. Remove the side and top panels according to **14.1.2, 14.1.3**.
4. Check to ensure that LEDs and display board are OFF.
5. Take out the insulation surrounding the compressor and the cover.
6. Remove the compressor electrical cover. Use flat screw driver if required.
7. Remove the compressor wires from the terminals.
8. Remove the compressor wires from the cable holders along the partition and secure the wire on the top of the unit to avoid its burning by the burner.
9. Disconnect the suction pipe from the compressor.
10. Disconnect the discharge pipe from the compressor.

Remove the four nuts fixing the compressor and remove the compressor by lifting.

NOTES for re-assembling new compressor:

1. To prevent contamination of the refrigerant with water or foreign particles, do not expose open pipes to atmosphere for long periods. If necessary, seal pipe ends using caps or tape.
2. Remove the caps for the new compressor just before replacing the compressor. Seal suction and discharge pipe using tape when mounting to prevent the foreign particles entering the compressor.

Check to ensure each wire color goes to correct compressor terminal. If wrongly connected, the compressor may fail due to reverse rotation.

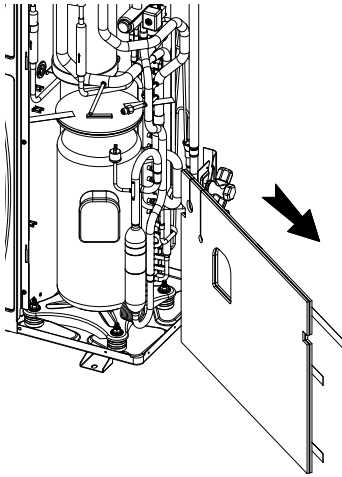

Removing Compressor Insulation

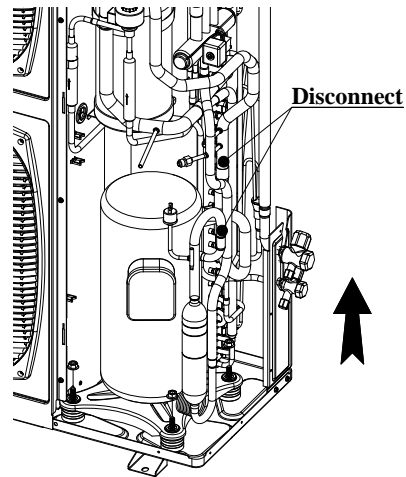

Removing Compressor

14.1.11 Removing Tubing Thermistors

1. Remove the service front panel according to **14.1.1**.
2. Remove the side and top panels according to **14.1.2**, **14.1.3**
3. Check to ensure that LEDs and display board are OFF.
4. Disconnect the thermistor connector from the main board.
5. Remove the thermistor wires from the cable holders along the electronics box.
6. Cut the nylon ties holding the wires to the pipes.
7. Pull up the spring from the housing while pulling the thermistor.

Notes for re-assemble the thermistor:

1. Make sure the spring is inserted first and is facing the tube to be attached to.
2. hold the thermistor wires to the tube with nylon tie holding both the wires and the protective sleeve.

14.1.12 Removing Outdoor Air Thermistor

1. Remove the service front panel according to **14.1.1**.
2. Remove the top panel according to **14.1.2**.
3. Check to ensure that LEDs and display board are OFF.
4. Disconnect the thermistor connector from the main board.
5. Remove the thermistor wires from the cable holders along the electronics box and the fan motor assembly.
6. Cut the nylon ties holding the wires to the metal chassis.

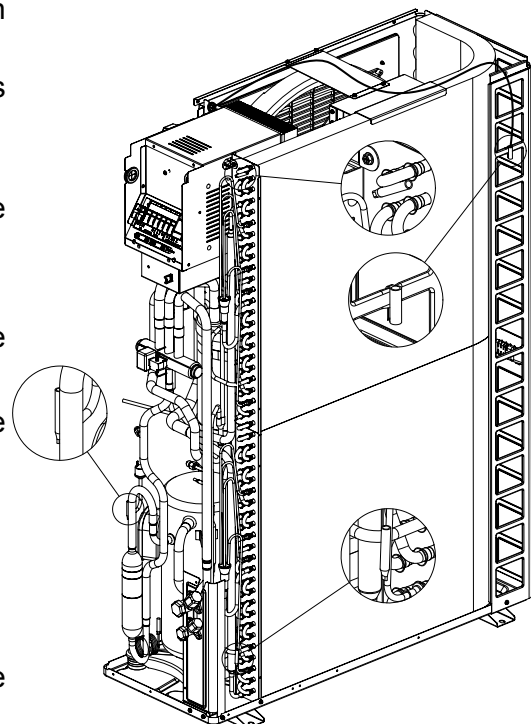

Removing Thermistors

14.1.13 Removing main board

1. Remove the service front panel according to **14.1.1**.
2. Check to ensure that LEDs and display board are OFF.
3. Disconnect all connectors from the main board.
4. Squeeze the 8 spacers head with Long-Nose Pliers and pull out the board.

Note: It might be easier to remove the main board panel first and then pull out the board from its spacers.

Notes for re-assemble the main board:

1. Make sure to correct all the connectors into the connect locations. If incorrectly connected, malfunction or damage to the electrical parts may occur.
2. Hold the wires to the cable holders.
3. Ensure to set all the dip switches to the same configuration as the original.

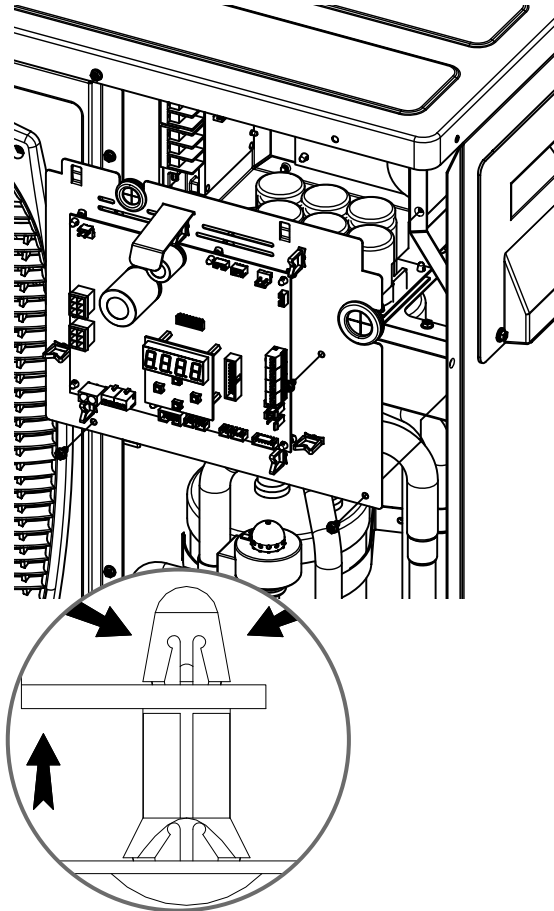

Removing main board Panel

14.1.14 Removing Electrical assembly

1. Remove the service front panel according to **14.1.1**.
2. Remove the side and top panels according to **14.1.2, 14.1.3**.
3. Check to ensure that LEDs and display board are OFF.
4. Disconnect the following connectors from the main board: RV, thermistors (4), HPS and EEV.
5. Remove the compressor electrical cover. Use flat screw driver if required.
6. Remove the compressor wires from the terminals.
7. Remove the three (3) screws fixing the electrical box to the front fan panel, the partition and the coil plate.
8. Pull up the box.

Notes for re-assemble the Electrical assembly:

1. Make sure to connect all the connectors into the right locations. If incorrectly connected, malfunction or damage to the electrical parts may occur.
2. Hold the wires to the cable holders.

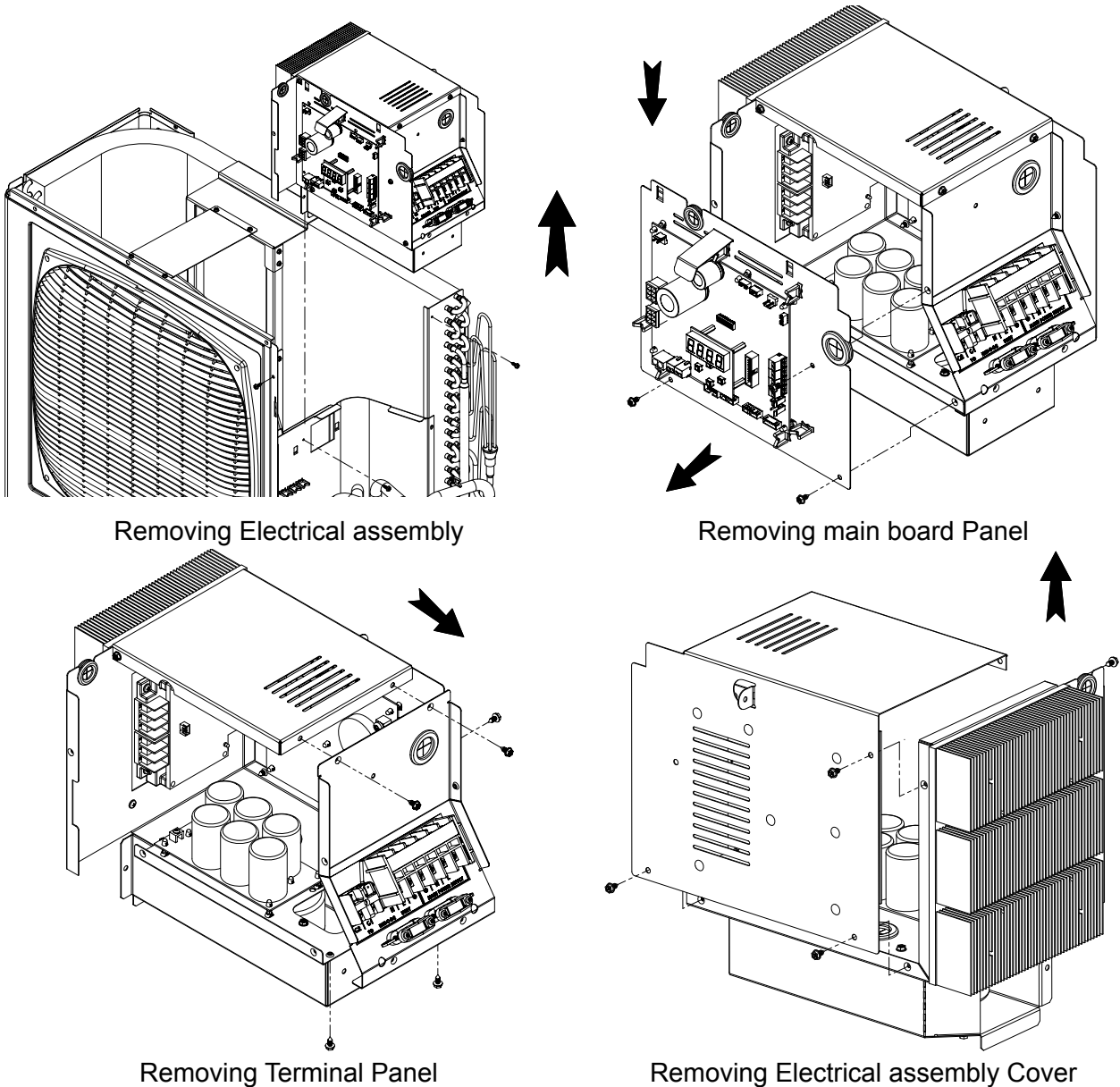

14.1.15 Removing driver module

14.1.15.1 GC 36 / 43

1. Remove the electrical assembly according to **4.1.14**.
2. Remove the three (3) screws fixing the main board panel to the assembly and take the panel out.
3. Remove the earth tab connection from the line filter.
4. Remove the five (5) screws fixing the terminal panel to the assembly and take the panel out.
5. Disconnect all the wires from the driver terminals and the communication connector.
6. Remove the five (5) screws fixing the line filter panel to the driver panel and take the panel out.
7. Remove the four (4) screws fixing the driver module to the heatsink.
8. Wipe out the grease paste with cloth soaked with alcohol.

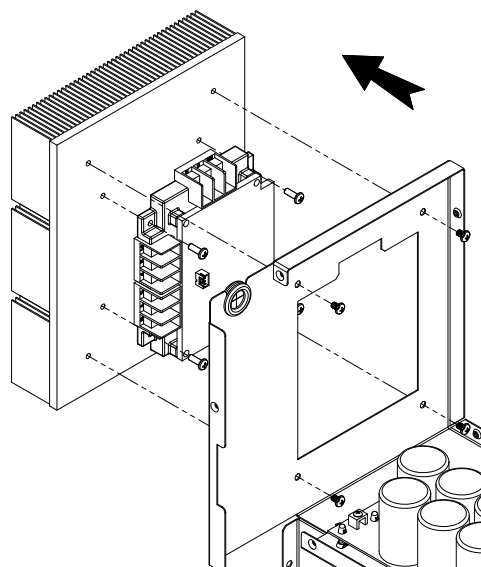

Removing driver module

Notes:

- Do not hold the PCB part of the driver module when removing the driver module.
- When handling the module, take care of not to use excessive force as this may cause damage.

14.1.15.2 GC 60

1. Remove the electrical assembly according to **14.1.14**.
2. Remove the three (4) screws fixing the main board panel to the assembly and take the panel out.
3. Remove the earth tab connection from the line filter.
4. Remove the five (5) screws fixing the terminal panel to the assembly and take the panel out.
5. Disconnect all the wires from the driver terminals and the communication connector.
6. Remove the five (5) screws fixing the back panel to the driver panel and take the panel out.
7. Remove the four (2) screws fixing the driver module to the heatsink.
8. Squeeze the 4 spacers head with Long-Nose Pliers and pull out the board.
9. Wipe out the grease paste with cloth soaked with alcohol.

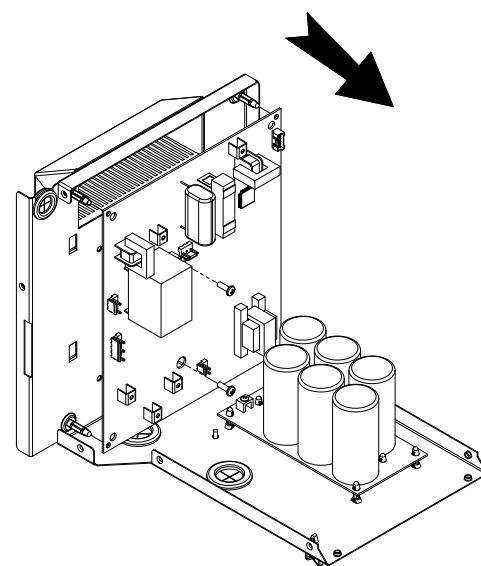

Removing driver module

Notes:

- Do not hold the PCB part of the driver module when removing the driver module.
- When handling the module, take care of not to use excessive force as this may cause damage.

14.1.16 Re-assembling driver module

14.1.16.1 GC 36 / 43.

Wipe out the heat sink and the driver plate with cloth soaked with alcohol. Wipe out the heat sink screw holes as well by inserting the cloth deeply into the holes but beware not to damage the screwing paths.

2. Spread thermal grease paste on the driver back plate. Grease thickness should be 0.1-0.15mm evenly spread.
3. Place the driver module according the picture and screw the 4 screws gently with torque meter of 0.25Nm by the following order: 1-3-4-2.
4. Further tighten the screw with torque meter of 1.2Nm, same order. Make 1 turn backward with each screw.
5. Wait for 1 hour and further tighten the screws with torque meter of 1.2 Nm, same order.
6. Perform the removal procedure in **14.1.15** backwards.

Notes:

- Do not hold the PCB part of the driver module when handling the driver module.
- When handling the module, take care of not to use excessive force as this may cause damage.

14.1.16.2 GC 60

1. Wipe out the heat sink and the driver plate with cloth soaked with alcohol. Wipe out the heat sink screw holes as well by inserting the cloth deeply into the holes but beware not to damage the screwing paths.
2. Spread thermal grease paste on the driver back plate. Grease thickness should be 0.1-0.15mm evenly spread.
3. Place the driver module according the picture and screw the 2 screws gently with torque meter of 0.25Nm.
4. Further tighten the screw with torque meter of 1.2Nm, same order. Make 1 turn backward with each screw.
5. Wait for 1 hour and further tighten the screws with torque meter of 1.2Nm.
6. Perform the removal procedure in **14.1.15** backwards.

Notes:

- Do not hold the PCB part of the driver module when handling the driver module.
When handling the module, take care of not to use excessive force as this may cause damage.

14.1.17 Removing Chocks Coils

14.1.17.1 GC 36 / 43

1. Perform the driver module removal procedure in **14.1.15** from 1 to 6.
2. Remove the 4 screws holding the chock coils box to the driver panel.
3. Take out the chock coils box while pulling the wires out through the rubber grommet.
4. Remove the chock coils wires from the terminal block.
5. Remove the 3 screws for each chock coil to release the chock coils from the box.

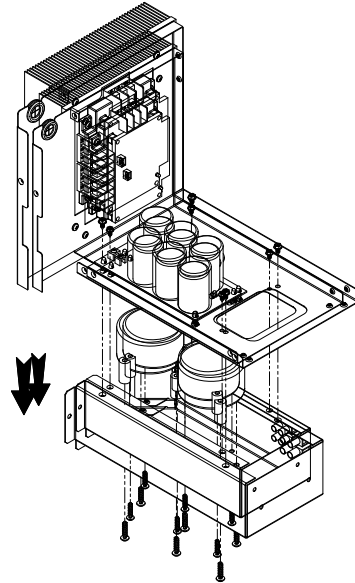

Removing Chocks Coils

14.1.17.2 GC 60

1. Remove the chock coils wires from the chock terminal block.
2. Remove the terminal block holde.
3. Remove the 2 screws for each chock coil to release the chock coils from the partition.

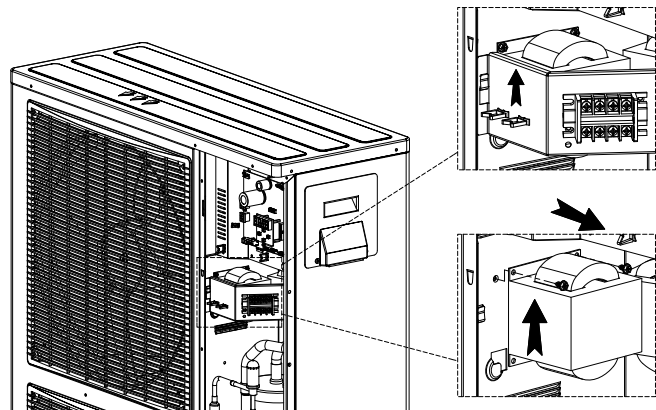

Removing Chocks Coils

14.1.18 Removing capacitor board

1. Perform the driver module removal procedure in **14.1.15** from 1 to 4. You may perform #6 as it will ease the board removal but first release N and L wires from the line filter.
2. Remove the capacitor wires from the board.
3. Squeeze the 6 spacers head with Long-Nose Pliers and pull out the board.

Notes to re-assemble the capacitor board:

- Capacitors has polarity (+ and -), check to ensure each terminal before connecting.

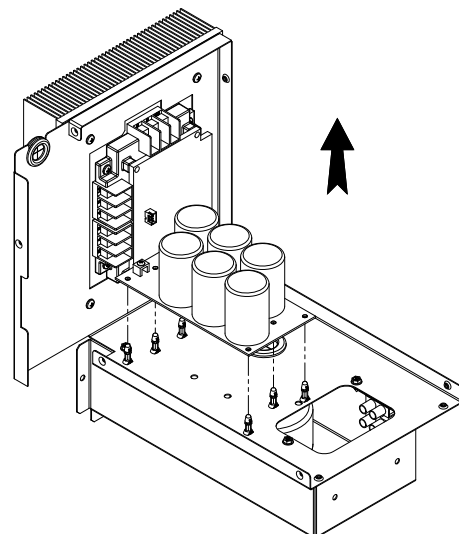

Removing capacitor board

14.1.19 Removing Line Filter board

14.1.19.1 GC 36 / 43

1. Perform the driver module removal procedure in **14.1.15** from 1 to 4 and #6 but first release N and L wires from the line filter.
2. Squeeze the 7 spacers head with Long-Nose Pliers and pull out the board.

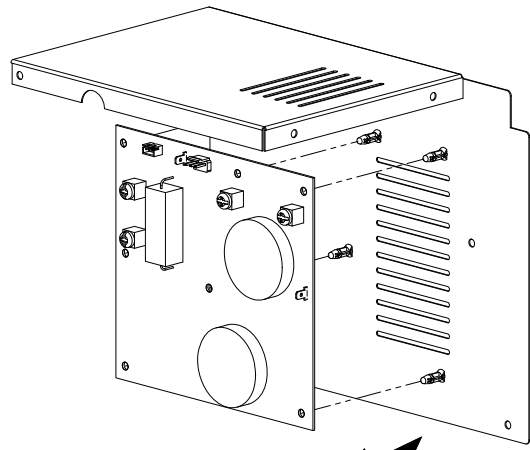

Removing Line Filter board

14.1.19.2 GC 60

1. Perform the driver module removal procedure in **14.1.15** from 1 to 4.
2. Release all wires from the line filter.
3. Squeeze the 4 spacers head with Long-Nose Pliers and pull out the board.

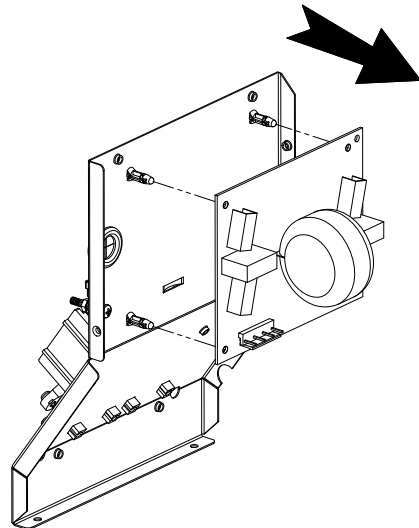

Removing Line Filter board

14.2 Indoor Unit: DLS

14.2.1 Electronics Assembly Remote Access

In cases of hard access to control assembly it is made possible to release the assembly from the indoor unit chassis.

1. Remove the 4 fixing screws and relocate the Electronics assembly .

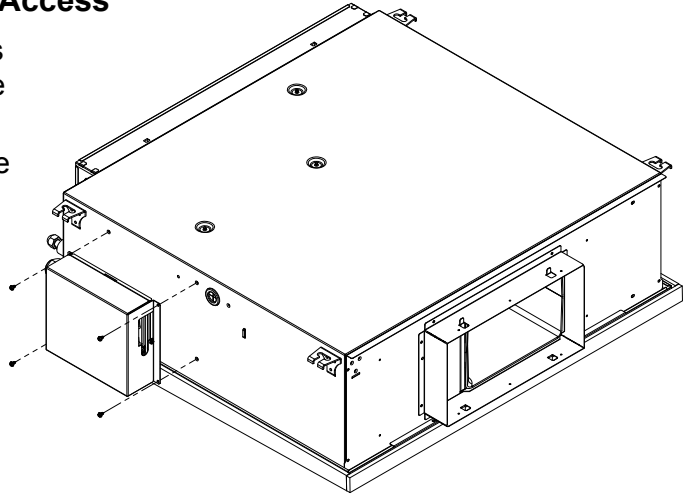

14.2.2 Removing Electronics Assembly

1. Remove the 2 fixing screws and take out the cover.
2. Disconnect all connectors and wires from the Electronics Board
3. Remove the 3 fixing screws and take out the Electronics Board.

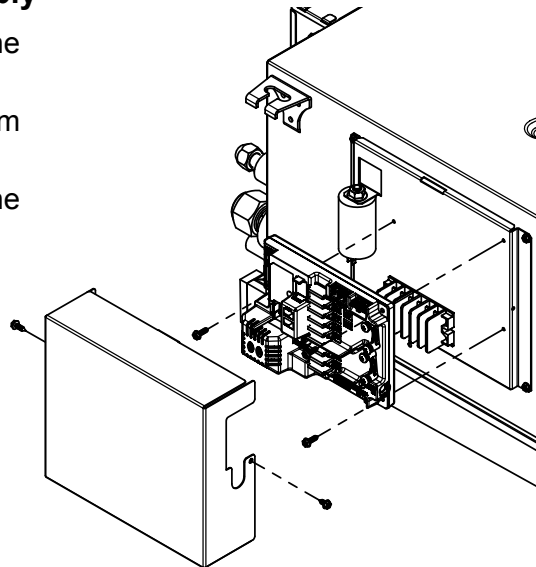

14.2.3 Removing Display unit

1. Take out the display connector from the electronics board.

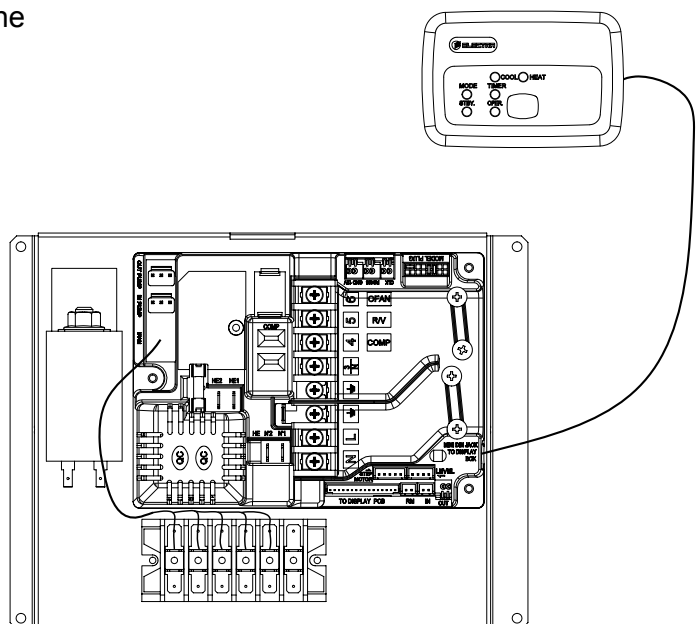

14.2.4 Removing Service Panel

1. Remove the 2 fixing screws from the filter side, push the service panel back and remove it.

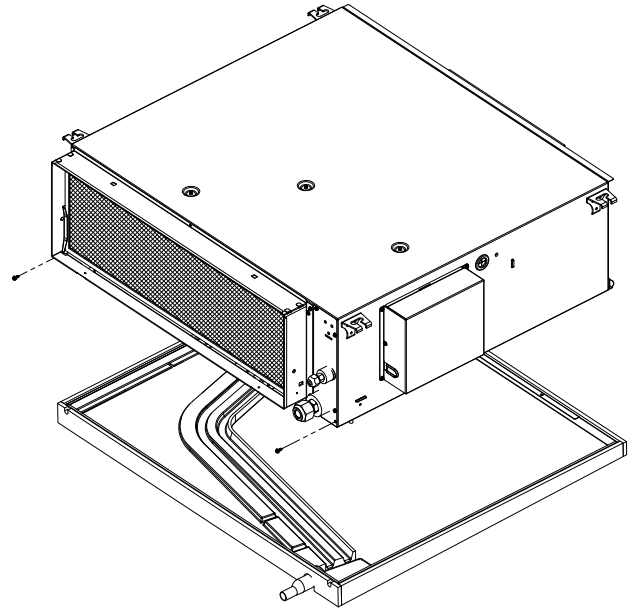

14.2.5 Removing Fan Assembly

1. Remove the Service Panel according to **14.2.4**.
2. Disconnect the motor connector inside the unit and cut off the nylon ties holding the motor cable.
3. Remove the 3 fixing screws and take out the Fan assembly.

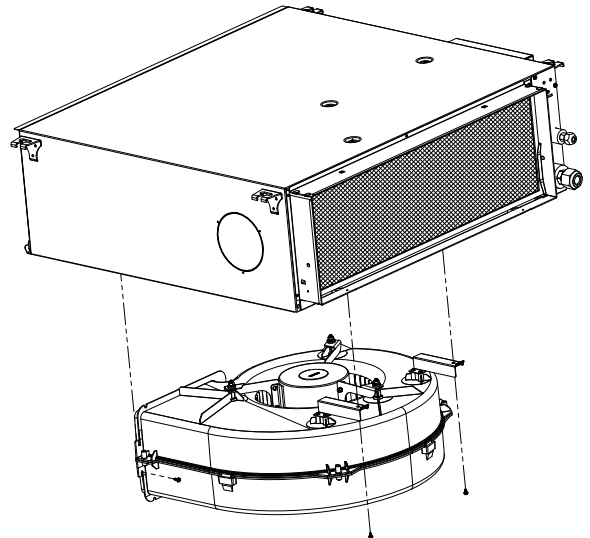

14.2.6 Removing Fan Motor

1. Remove the Fan Assembly according to **14.2.5**.
2. Remove the hex nut and the spring washer from the motor shaft.
3. Remove the 3 fixing hex nuts and the spring washers that connect the legs support to fan house and take out the motor with the 3 legs.
4. Remove the 6 fixing screw and nuts that connect the legs support with the fan motor and separate them.

14.2.7 Removing Fan

1. Remove the Fan Assembly according to **14.2.6**.
2. Remove the 4 fixing screws and separate the fan house.
3. Remove the hex nut and the spring washer from the motor shaft and take out the fan.

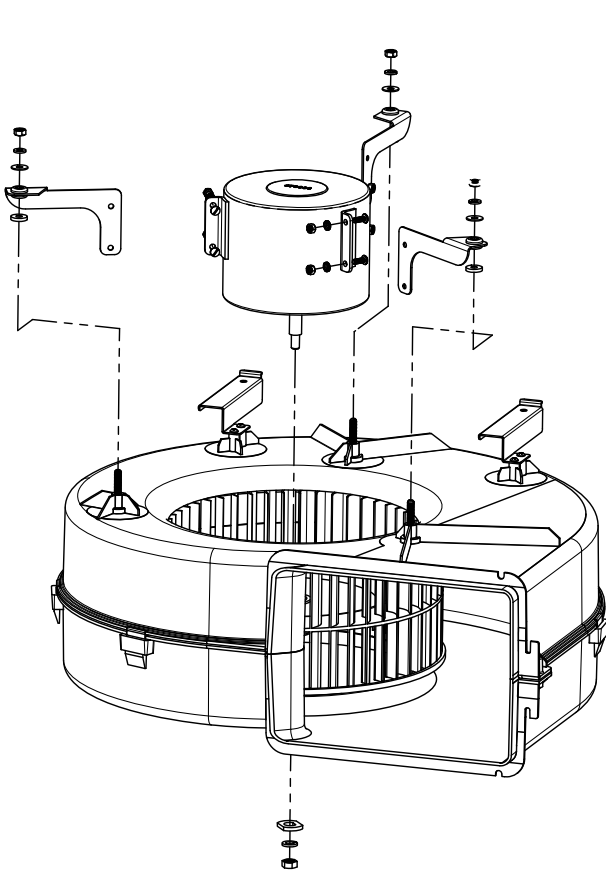

14.2.6 Removing Fan Motor

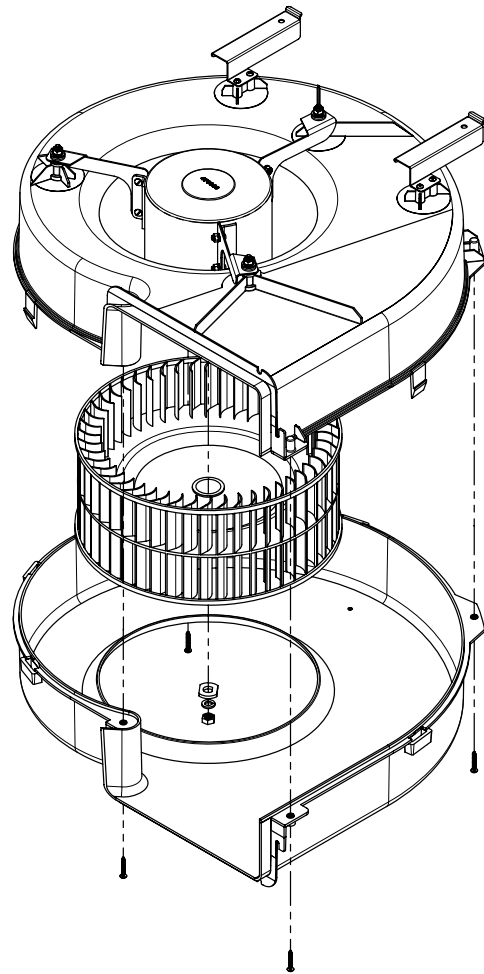

14.2.7 Removing Fan

14.2.8 Removing motor capacitor

1. Disconnect the tab connections from the to be capacitor.
2. Remove the nut holding the capacitor to be holder.

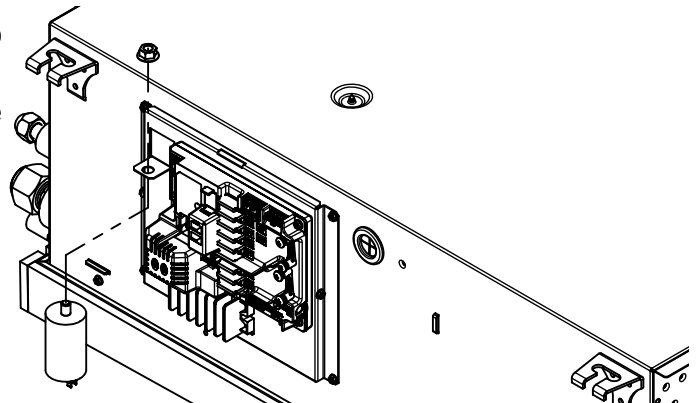

14.2.9 Removing Thermistors

1. Disconnect the thermistor connector from the main board.
2. Cut the nylon ties holding the wires to the pipes or chassis.

ICT thermistor only - Pull up the spring from the housing while pulling out the thermistor.

Notes for re-assemble the ICT thermistor:

1. Make sure the spring is inserted first and is facing the tube to be attached to. Hold the thermistor wires to the tube with nylon tie holding both the wires and the protective sleeve

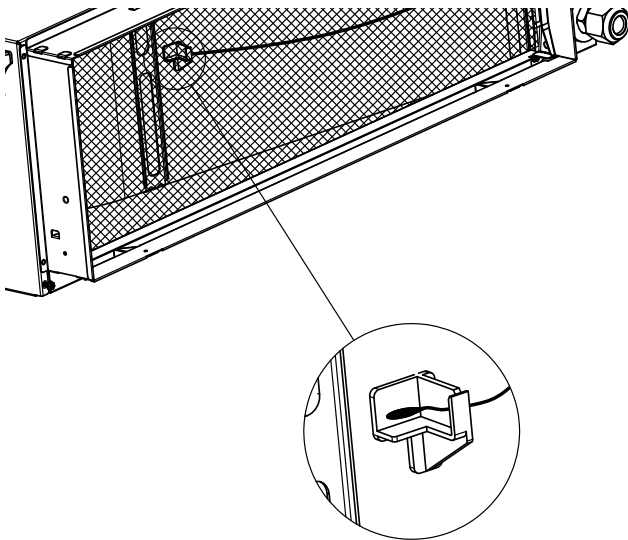

Indoor Air Thermistor (RAT)

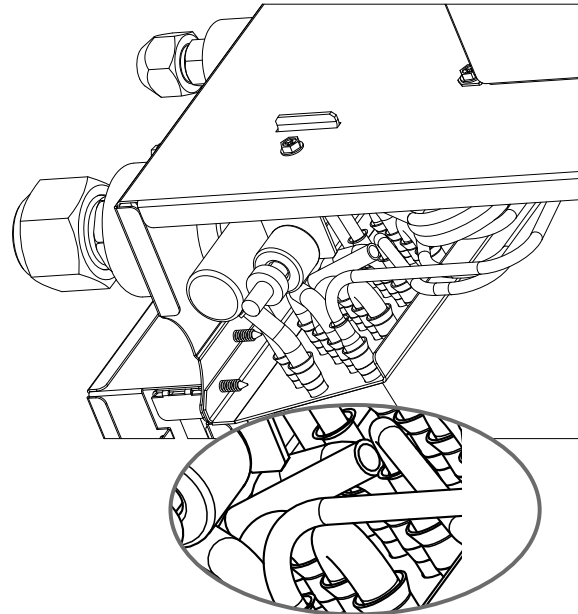

Indoor Coil Thermistor (ICT)

14.2.10 Removing Float Switch

1. Disconnect the wire to wire float switch connector inside the unit.
2. Cut the nylon ties holding the wires to the pipes or chassis.
3. Remove the screw holding the switch holder to the unit chassis.
4. Use two open spanners to remove the nylon nuts of the switch and take out the switch.

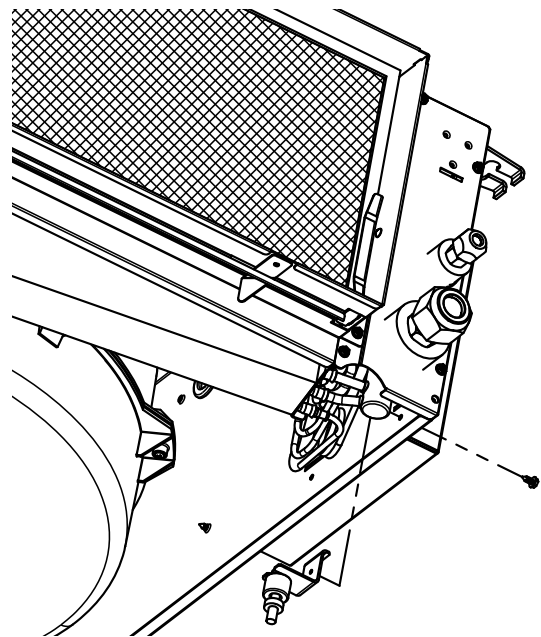

14.3 Indoor Unit: DHC

14.3.1 Electronics Assembly Remote Access

In cases of hard access to control assembly it is made possible to release the assembly from the indoor unit chassis.

1. Remove the 4 fixing screws and relocate the Electronics assembly .

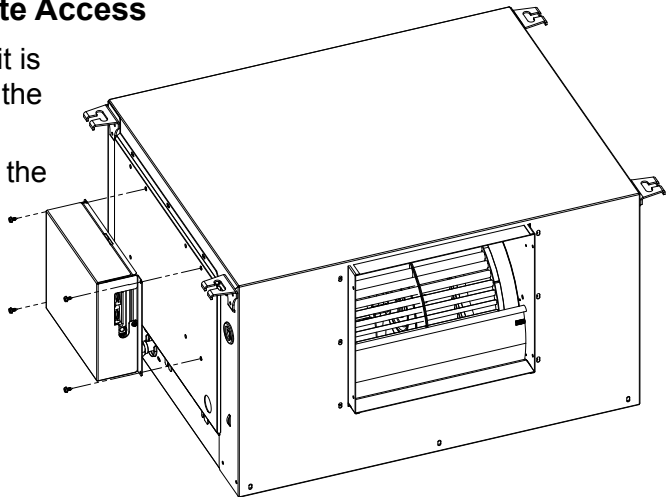

14.3.2 Removing Electronics Assembly

1. Remove the 2 fixing screws and take out the cover.
2. Disconnect all connectors and wires from the Electronics Board.
3. Remove the 3 fixing screws and take out the Electronics Board.

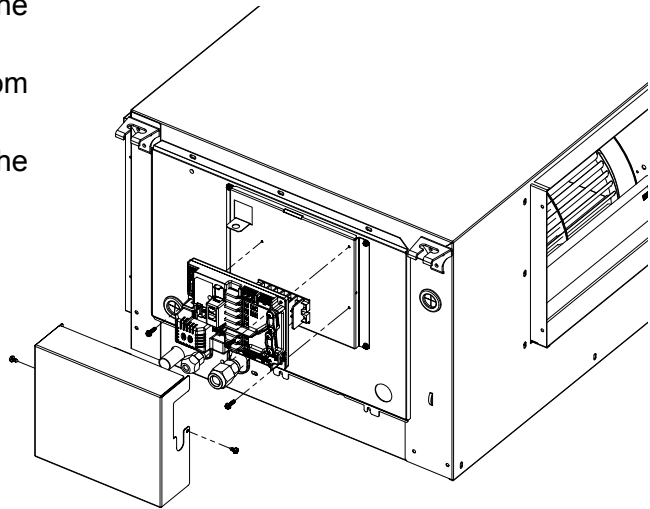

14.3.3 Removing Display unit

1. Take out the display connector from the electronics board.

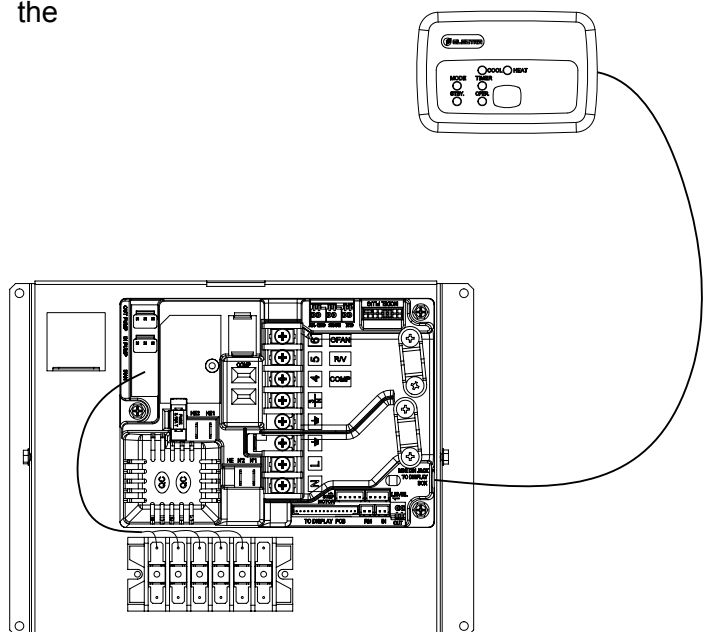

14.3.4 Removing Service Panel

1. Remove the 6 fixing screws and pull the service panel to remove it.

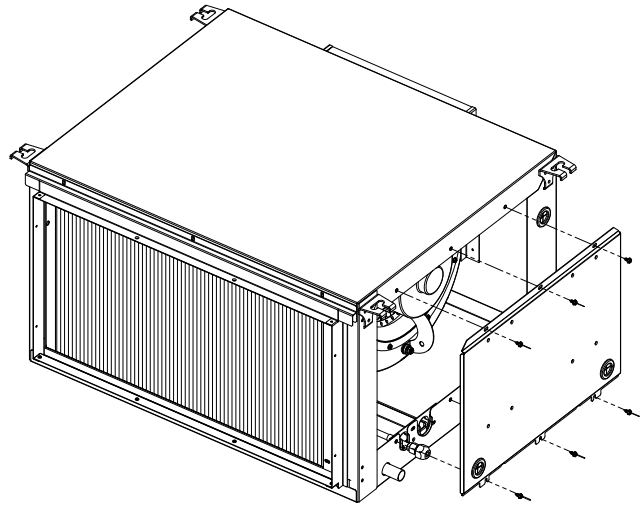

14.3.5 Removing Fan and Fan Motor

7. Disconnect the motor connector from the Electronics Board.
8. Remove the Service Panel according to **14.3.4**.
9. Push the motor cable back into the unit through the grommet.
10. Remove the 6 fixing screw connecting the ring to the fan housing.
11. Remove the 3 fixing hex nuts and the spring washers that connect the legs support to fan house and take out the motor with the 3 legs.
12. Release the allen screw fixing the fan to fan motor axis and separate it.

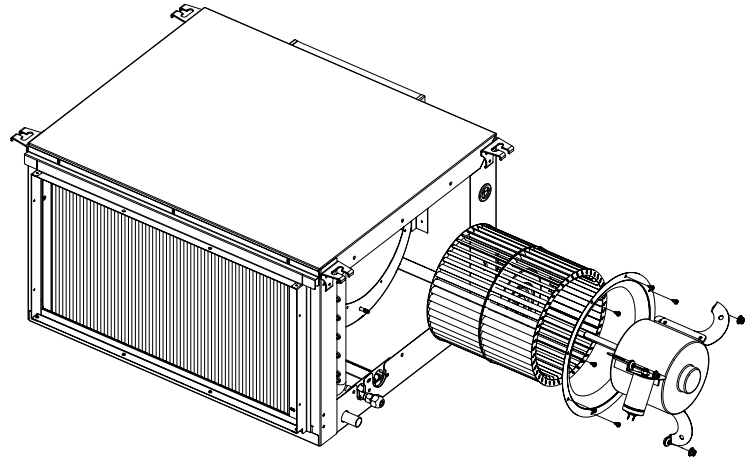

14.3.6 Removing motor Capacitor

1. Remove the Service Panel according to **14.3.4**.
2. Disconnect the tab connections from the capacitor.
3. Remove the nut holding the capacitor to the holder.

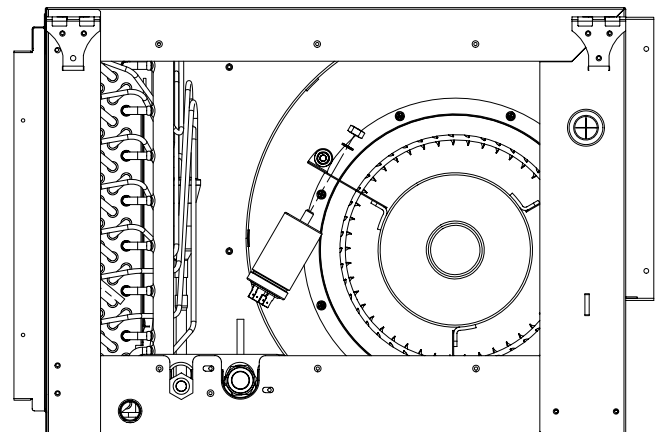

14.3.7 Removing Thermistors

1. Disconnect the thermistor connector from the main board.
2. Cut the nylon ties holding the wires to the pipes or chassis.

ICT thermistor only - Pull up the spring from the housing while pulling out the thermistor.

Notes for re-assemble the ICT thermistor:

1. Make sure the spring is inserted first and is facing the tube to be attached to. Hold the thermistor wires to the tube with nylon tie holding both the wires and the protective sleeve

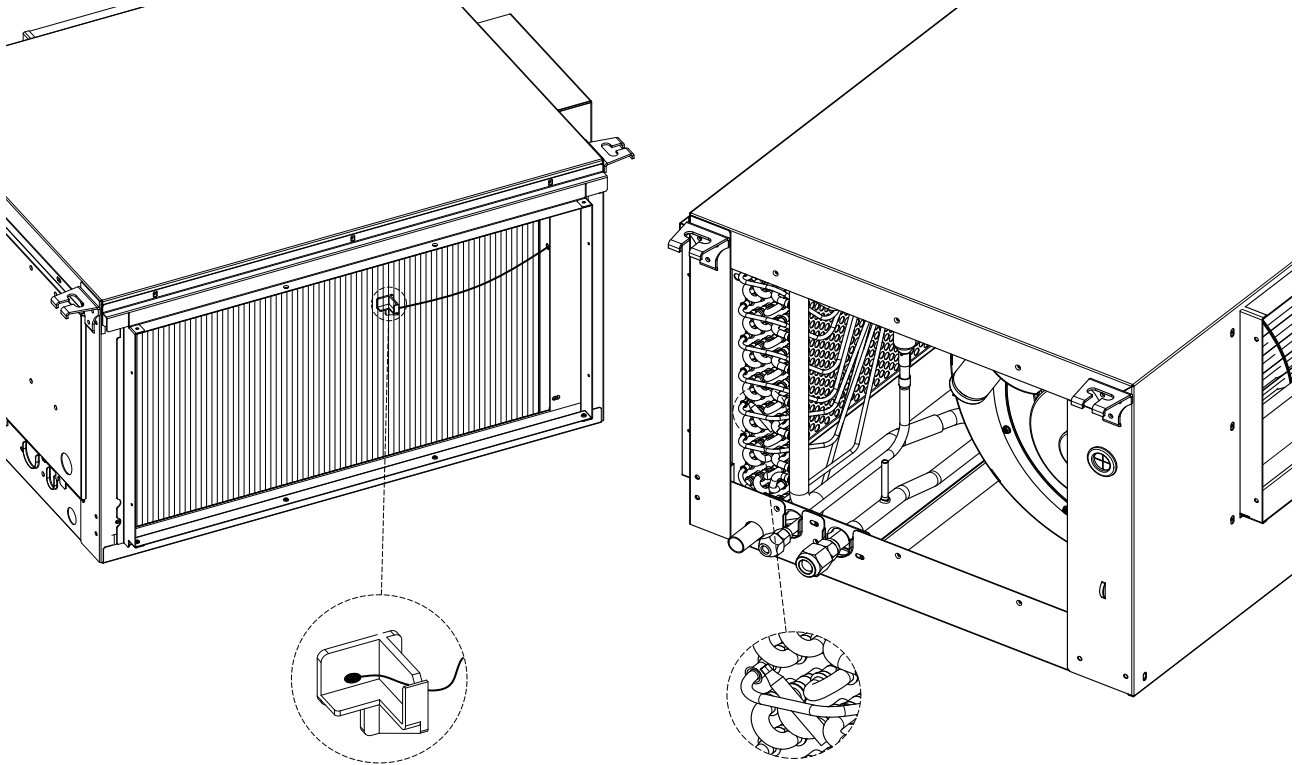

Indoor Air Thermistor (RAT)

Indoor Coil Thermistor (ICT)

14.4 Indoor Unit: CD

14.4.1 Electronics Assembly Remote Access

In cases of hard access to control assembly it is made possible to release the assembly from the indoor unit chassis.

1. Remove the 4 fixing screws and relocate the Electronics assembly .

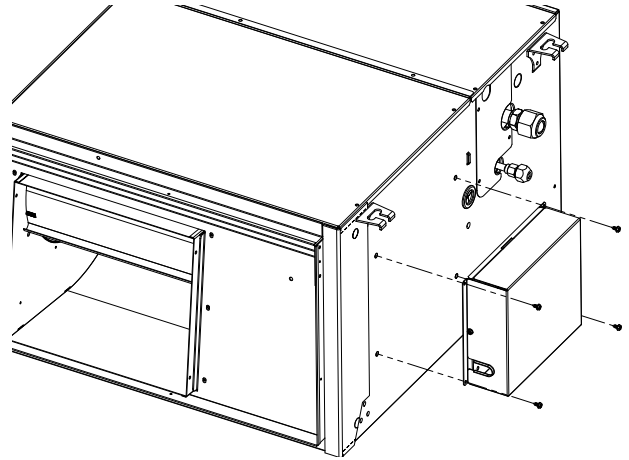

14.4.2 Removing Electronics Assembly

1. Remove the 2 fixing screws and take out the cover.
2. Disconnect all connectors and wires from the Electronics Board
3. Remove the 3 fixing screws and take out the Electronics Board.

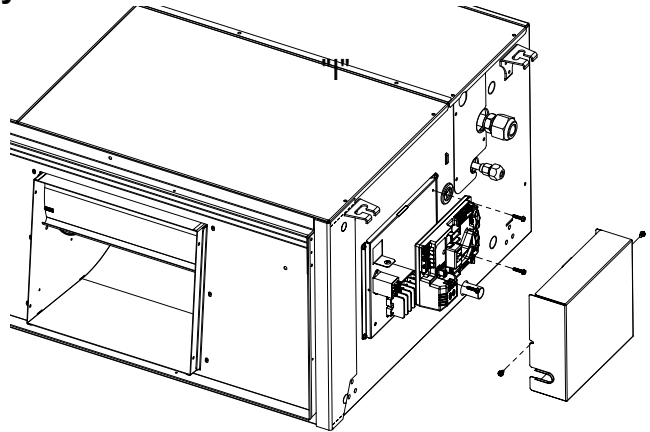

14.4.3 Removing Display Unit

1. Take out the display connector from the electronics board.

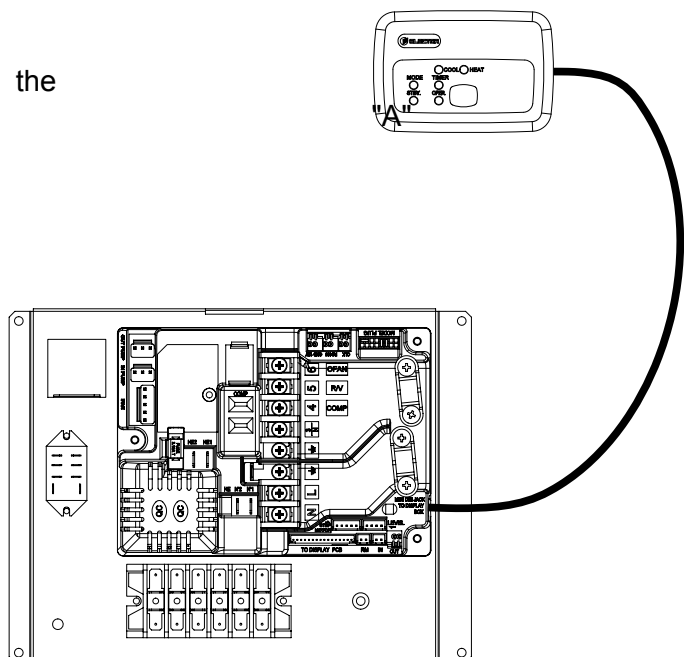

14.4.4 Removing Service Panels

1. Remove the 15 fixing screws and pull the service panel to remove it.

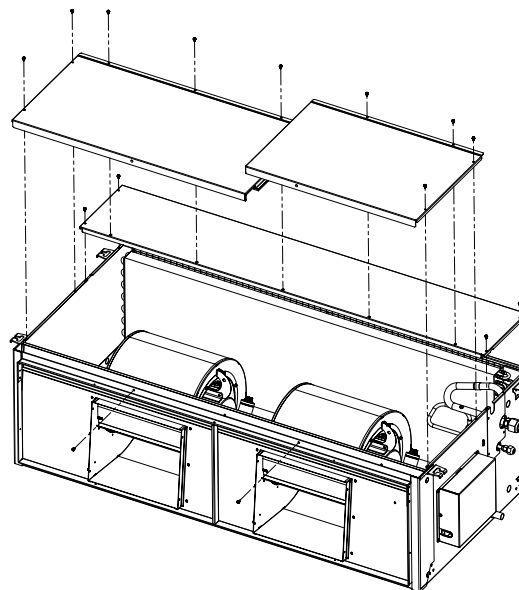

14.4.5 Removing Fan and Fan Motor

1. Disconnect the motor connectors from the Electronics Board.
2. Remove the Service Panel according to **14.3.4**.
3. Push the motors cable back into the unit through the gromet.
4. Remove the 2 fixing screw connecting the fan housing assembly to base and pull it .
5. Remove the 6 fixing screw connecting the ring to the fan housing.
6. Remove the 3 fixing hex nuts and the spring washers that connect the legs support to fan house and take out the motor with the 3 legs.
7. Release the allen screw fixing the fan to fan motor axis and separate it.

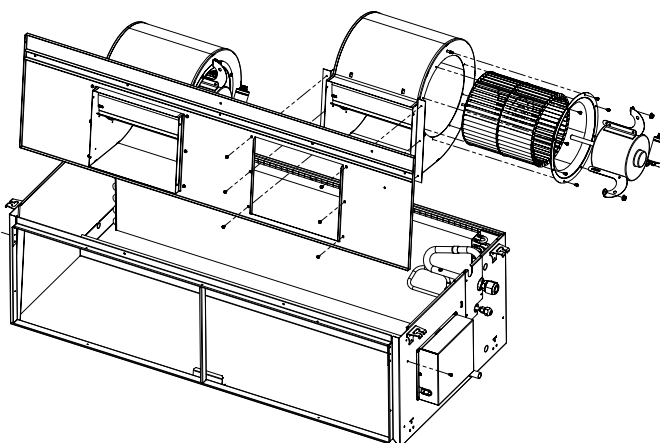

14.4.6 Removing Motor Capacitor

1. Remove the Service Panels, from fans side only, according to **14.3.4**.
2. Disconnect the tab connections from the capacitor.
3. Remove the nut holding the capacitor to the holder.

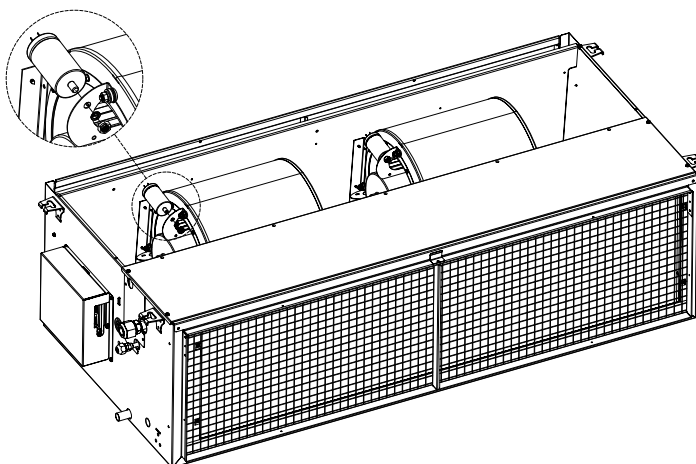

14.4.7 Removing Thermistors

1. Disconnect the thermistor connector from the main board.
 2. Cut the nylon ties holding the wires to the pipes or chassis.
- ICT thermistor only - Pull up the spring from the housing while pulling out the thermistor.

Notes for re-assemble the ICT thermistor:

1. Make sure the spring is inserted first and is facing the tube to be attached to. Hold the thermistor wires to the tube with nylon tie holding both the wires and the protective sleeve.

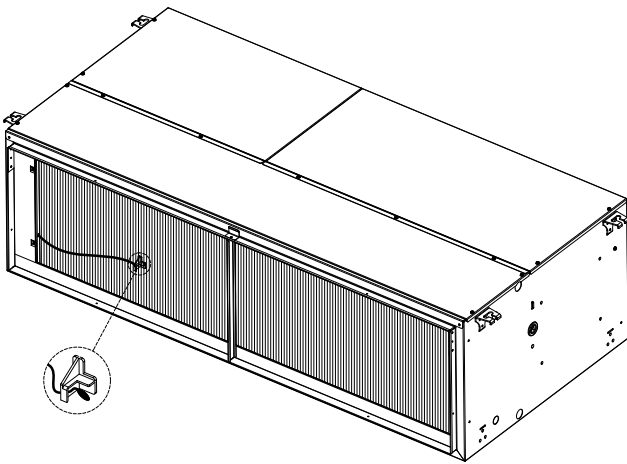

Indoor Air Thermistor (RAT)

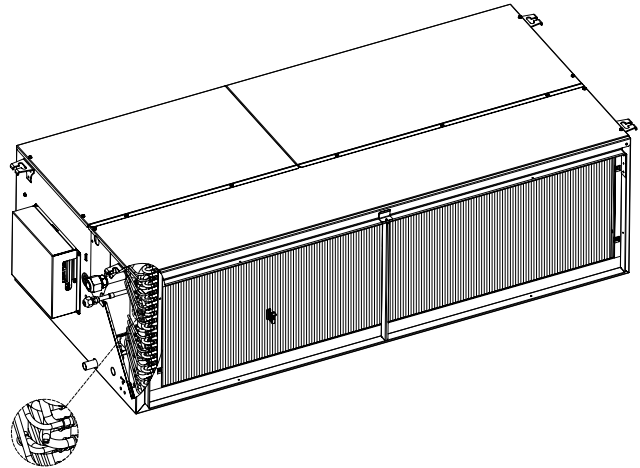

Indoor Coil Thermistor (ICT)

14.4.8 Removing Float Switch

1. Remove the Service Panel, from fan only, according to **14.3.4**.
2. Disconnect the wire to wire float switch connector inside the unit.
3. Cut the nylon ties holding the wires to pipes or chassis.
4. Use 2 open spanners to remove the nuts of the switch and take out the switch

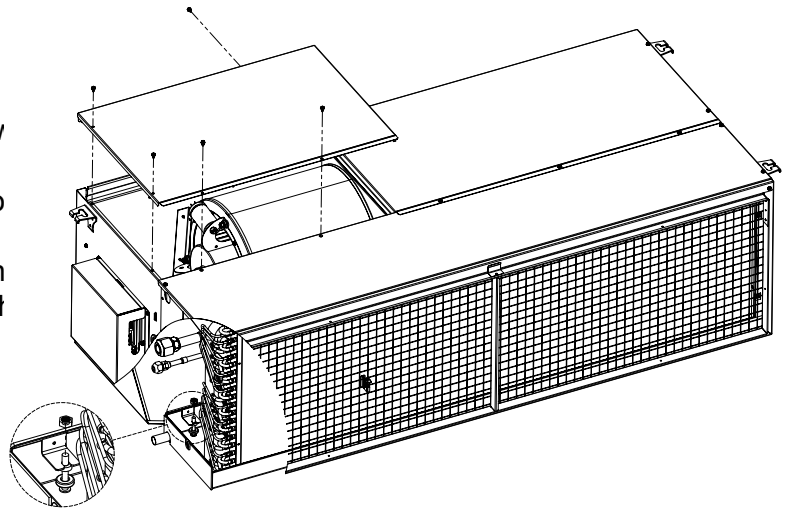

15. EXPLODED VIEWS AND SPARE PARTS LISTS

15.1 Indoor Unit: DLS 36, DLS 43 DCI - Exploded View

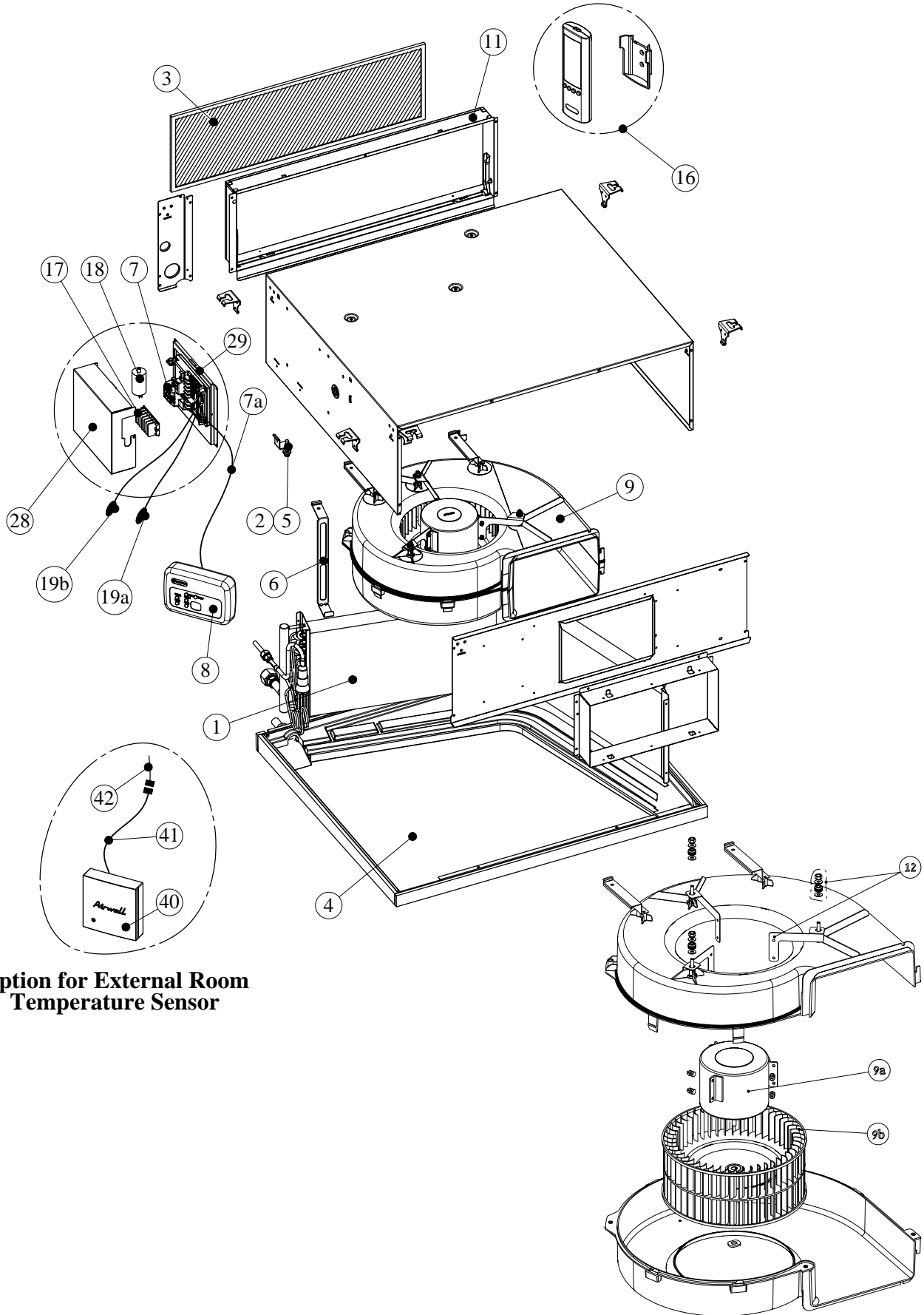

15.2 Indoor Unit: DLS 36 DCI - Spare Part List

No.	Part No.	Description	Qty
1	473525	IU COIL GR/HDR DLS 36 DCI	1
2	473231	FLOAT SUPPORT DLS	1
3	473902	DLS METAL FILTER 37-44	1
4	473247	INSULATED DRAIN POOL ASSY DLS	1
5	473700	DLS OVER FLOW SWITCH	1
6	473211	COIL SUPPORT DLS 44	1
7	467300107R	DCI 456 HP IDU STORM	1
7a	404020	CABLE 8 WIRES 7M WTH CONNECTOR	1
8	438778	WIRED DISPLAY BOX DHC/ELD (RoHS)	1
9	473906	FAN HOUSING ASSY DLS 37-44	1
9a	473006	MOTOR DLS 37/44	1
9b	473301	CENTRIFUGAL FAN DLS 300/130	1
11	473249	AIR FILTER FRAME ASSY DLS 37-4	1
12	473250	MOTOR LEG ASSY DLS	3
16	438783	REMOTE CONTROL RC4/RC (RoHS)	1
17	430535	*TERMINAL BLOCK RW-52 P6/90	1
18	442019	CAPACITOR 8mF 400V P1/P2	1
19a	473720	THERMISTOR+CAP WITH CONNECTOR	1
19b	473710	THERMISTOR WITH CONNECTOR L235	1
28	473415	ELECTRICAL COVER DLS DCI	1
29	473416	ELECTRICAL BASE PANEL DLS DCI	1
Option for External Room Temperature Sensor			
40	442297	THERMISTOR BOX AIRWELL	1
41	467030054	SHIELDED DEFROST CABLE	1
42	442296	ADAPTOR THERMISTOR WTH CONNE	1

15.3 Indoor Unit: DLS 43 DCI - Spare Part List

No.	Part No.	Description	Qty
1	473532	IU COIL GR/HDR DLS 43 DCI	1
2	473231	FLOAT SUPPORT DLS	1
3	473902	DLS METAL FILTER 37-44	1
4	473247	INSULATED DRAIN POOL ASSY DLS	1
5	473700	DLS OVER FLOW SWITCH	1
6	473245	COIL SUPPORT DLS 37	1
7	467300107R	DCI 456 HP IDU STORM	1
7a	404020	CABLE 8 WIRES 7M WTH CONNECTOR	1
8	438778	WIRED DISPLAY BOX DHC/ELD (RoHS)	1
9	473906	FAN HOUSING ASSY DLS 37-44	1
9a	473006	MOTOR DLS 37/44	1
9b	473301	CENTRIFUGAL FAN DLS 300/130	1
11	473249	AIR FILTER FRAME ASSY DLS 37-4	1
12	473250	MOTOR LEG ASSY DLS	3
16	438783	REMOTE CONTROL RC4/RC (RoHS)	1
17	430535	*TERMINAL BLOCK RW-52 P6/90	1
18	442019	CAPACITOR 8mF 400V P1/P2	1
19a	473720	THERMISTOR+CAP WITH CONNECTOR	1
19b	473710	THERMISTOR WITH CONNECTOR L235	1
28	473415	ELECTRICAL COVER DLS DCI	1
29	473416	ELECTRICAL BASE PANEL DLS DCI	1
Option for External Room Temperature Sensor			
40	442297	THERMISTOR BOX AIRWELL	1
41	467030054	SHIELDED DEFROST CABLE	1
42	442296	ADAPTOR THERMISTOR WTH CONNE	1

15.4 Indoor Unit: DHC 36 DCI - Exploded View

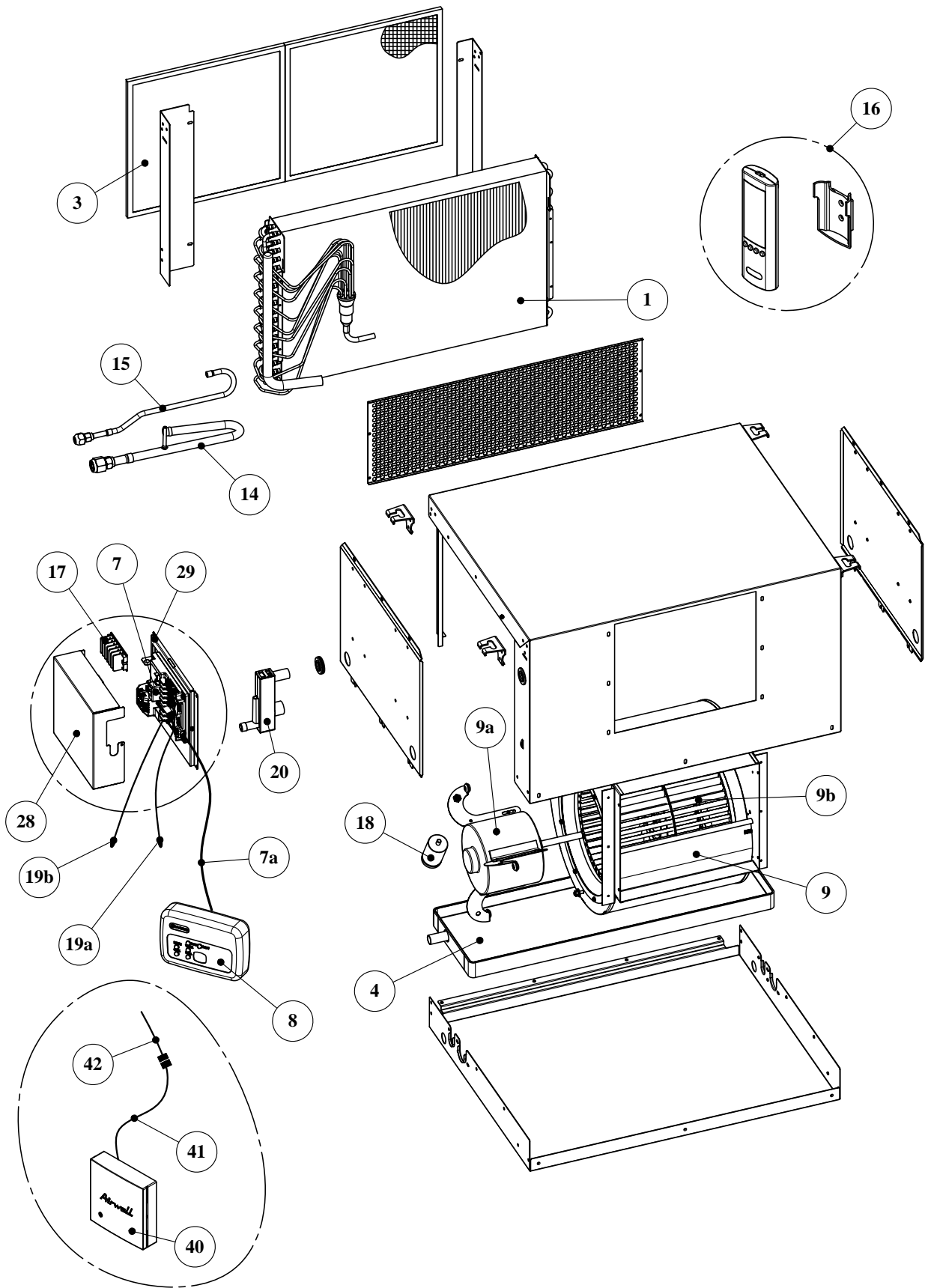

**Option for External Room
Temperature Sensor**

15.5 Indoor Unit: DHC 36 DCI - Spare Part List

No.	Part No.	Description	Qty
1	439978	IU COIL GR/HDR DHC 34/ 100	1
3	402347	AIR FILTER DHC 775-1000	2
4	438032	RT DRAIN PAN ASSY 3/4 DHCB 2	1
7	467300107R	DCI 456 HP IDU STORM	1
7a	404020	CABLE 8 WIRES 7M WTH CONNECT	1
8	438778	WIRED DISPLAY BOX DHC/ELD (R	1
9	182241	RT FAN MOTOR DD9*9 CAP. P2	1
9a	402003	MOTOR 343W, 4S, DHC 1100	1
9b	435413	FAN 240*240	1
14	434762	RT OUTLET ASSY DHC 24 R410A	1
15	439980	RIGHT INLET MANIFOLD ASSY EM	1
16	4527178R	REMOTE CONTROL RC RC7 GRAY	1
17	430535	*TERMINAL BLOCK RW-52 P6/90	1
18	442015	CAPACITOR 15mF 400V P1/P2	1
19a	400275	THERMISTOR+CAP WTH CONNECTOR	1
19b	402701	THERMISTOR WTH CONNECTORS L1800	1
20	438056	DRAIN SIPHON ASSY	1
28	473415	ELECTRICAL COVER DLS DCI	1
29	473416	ELECTRICAL BASE PANEL DLS DC	1
Option for External Room Temperature Sensor			
40	442297	THERMISTOR BOX AIRWELL	1
41	467030054	SHIELDED DEFROST CABLE	1
42	442296	ADAPTOR THERMISTOR WTH CONNE	1

15.6 Indoor Unit: DHC 43 DCI - Exploded View

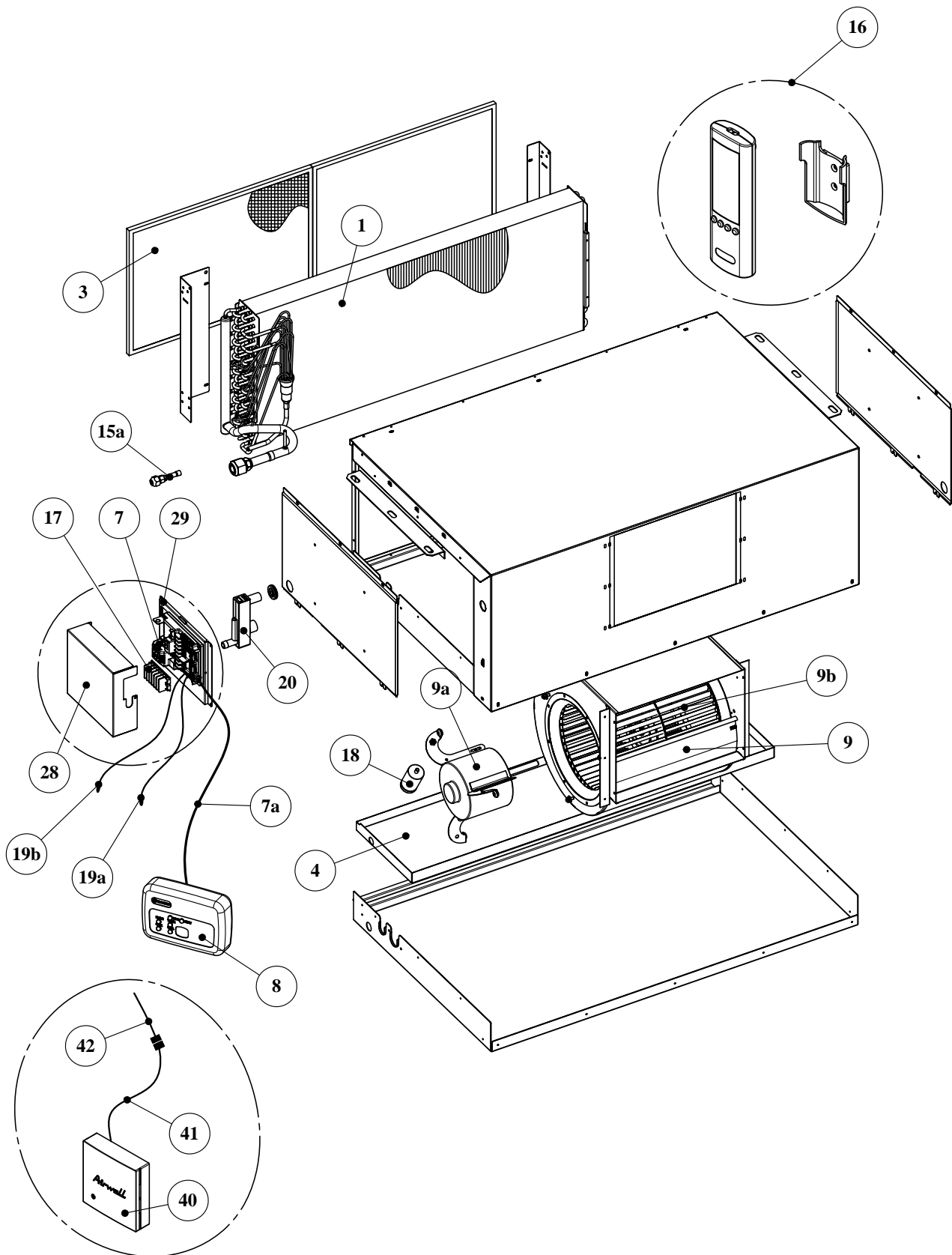

Option for External Room Temperature Sensor

15.7 Indoor Unit: DHC 43 DCI - Spare Part List

No.	Part No.	Description	Qty
1	439991	RT IU COIL GR/HDR DHC 43 DCI	1
3	402083	AIR FILTER DHC 1800	2
4	438069	DRAIN PAN ASSY DHCB60	1
7	467300107R	DCI 456 HP IDU STORM	1
7a	404020	CABLE 8 WIRES 7M WTH CONNECTOR	1
8	438778	WIRED DISPLAY BOX DHC/ELD (RoH	1
9	182244	RT FAN MOTOR DD9*11 CAP. P2 EM	1
9a	186320	MOTOR 371W, 4S, DHC1400	1
9b	435410	FAN 253*298	1
15a	433223	SOCKET FLARE ASSY 3/8"	1
16	4527178R	REMOTE CONTROL RC RC7 GRAY	1
17	430535	*TERMINAL BLOCK RW-52 P6/90	1
18	442018	CAPACITOR 10mF 400V P1/P2	1
19a	400275	THERMISTOR+CAP WTH CONNECTOR L	1
19b	402701	THERMISTOR WTH CONNECTORS L1800	1
20	438056	DRAIN SIPHON ASSY	1
28	473415	ELECTRICAL COVER DLS DCI	1
29	473416	ELECTRICAL BASE PANEL DLS DCI	1
Option for External Room Temperature Sensor			
40	442297	THERMISTOR BOX AIRWELL	1
41	467030054	SHIELDED DEFROST CABLE	1
42	442296	ADAPTOR THERMISTOR WTH CONNECT	1

15.8 Indoor Unit: CD 60 DCI - Exploded View

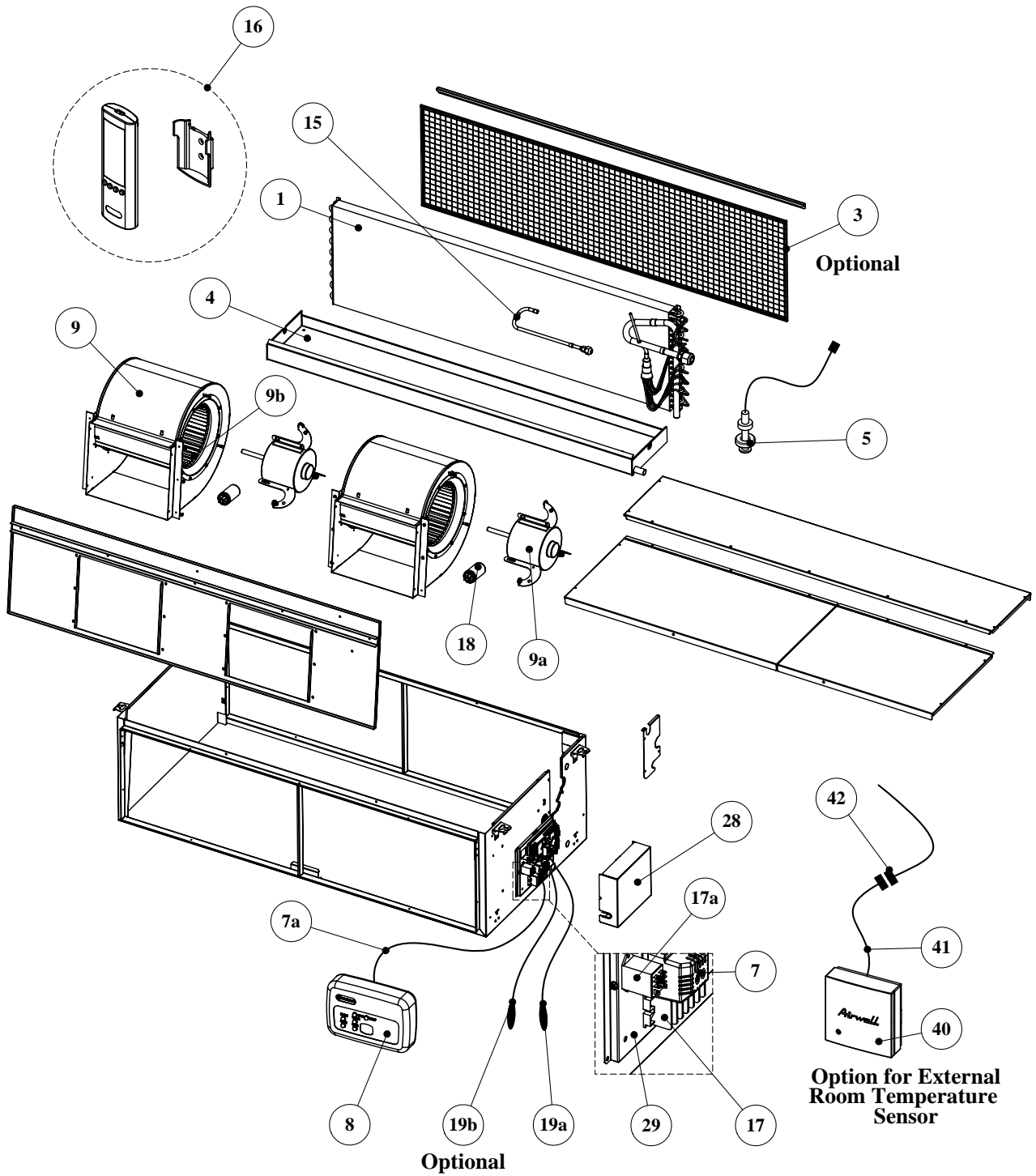

15.9 Indoor Unit: CD 60 DCI - Spare Part List

No.	Part No.	Description	Qty
1	475530	Indoor Coil 3Rows 7mm CD60 DCI	1
3	221546	AIR FILTER CD 60	1
4	475015	INSULATED DRAIN PAN ASSY CD 60	1
5	473700	DLS OVER FLOW SWITCH	1
7	467300208R	STORM DCI 6HP	1
7a	404020	CABLE 8 WIRES 7M WTH CONNECTOR	1
8	438778	WIRED DISPLAY BOX DHC/ELD (RoHS)	1
9	182241	RT FAN MOTOR DD9*9 CAP. P2	2
9a	402003	MOTOR 343W, 4S, DHC 1100	2
9b	435413	FAN 240*240	2
15	475536	Right Inlet Manifold Assembly	1
16	438783	REMOTE CONTROL RC4/RC (RoHS)	1
17	430535	TERMINAL BLOCK RW-52 P6/90	1
17a	192106	RELAY 230V 10A	1
18	442015	CAPACITOR 15mF 400V P1/P2	2
19a	400275	THERMISTOR+CAP WTH CONNECTOR	1
19b	402701	THERMISTOR WTH CONNECTORS	1
28	473415	ELECTRICAL COVER DLS DC	1
29	473416	ELECTRICAL BASE PANEL DLS DCI	1
Option for External Room Temperature Sensor			
40	442297	THERMISTOR BOX AIRWELL	1
41	467030054	SHIELDED DEFROST CABLE	1
42	442296	ADAPTOR THERMISTOR WTH CONNECTORS	1

15.10 GC 36 / 43 DCI - Exploded View

15.10.1 Outdoor Unit General Assembly

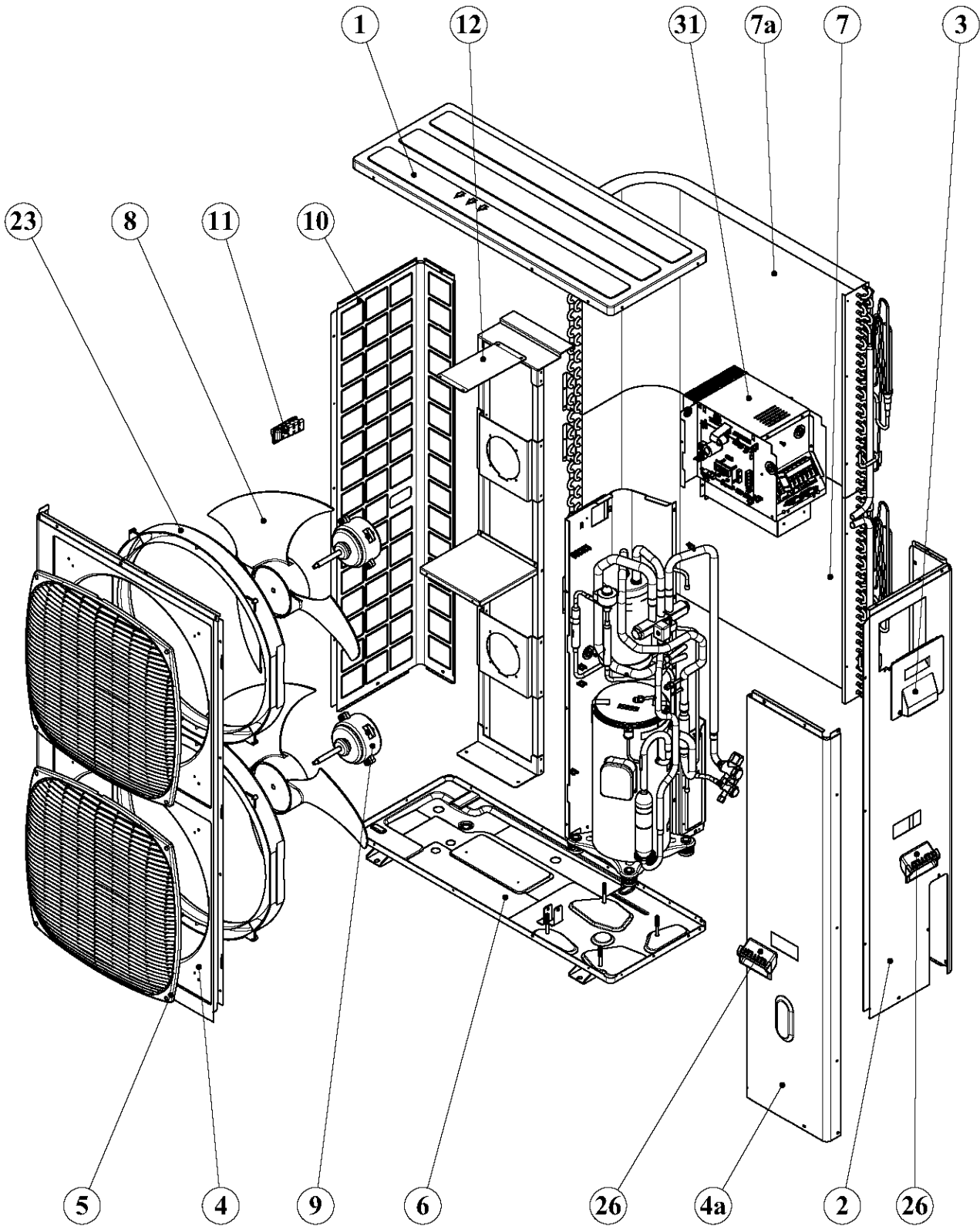

15.10.2 Outdoor Unit Tubing Assembly

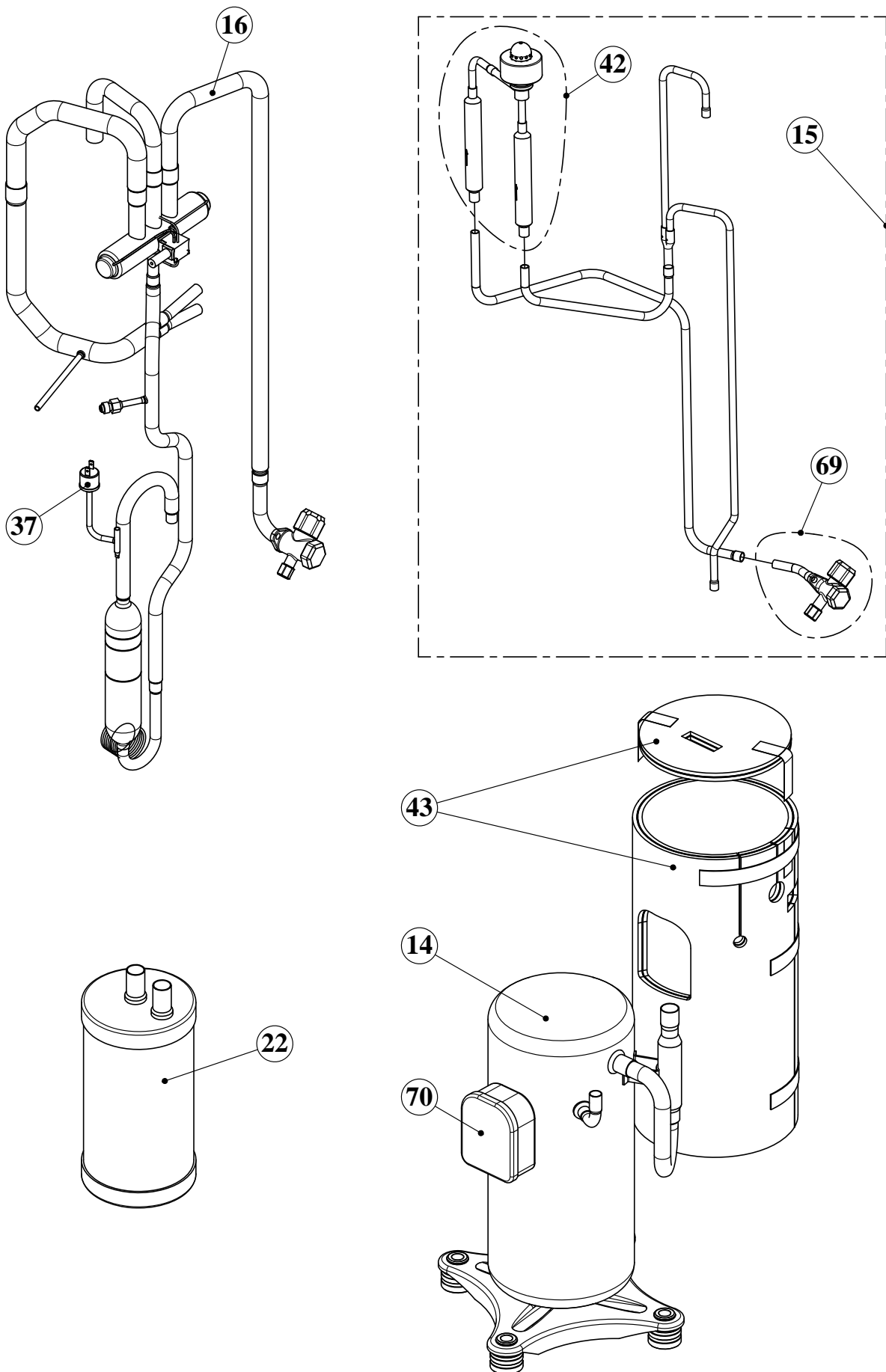

15.10.3 Outdoor Unit Electronics Assembly

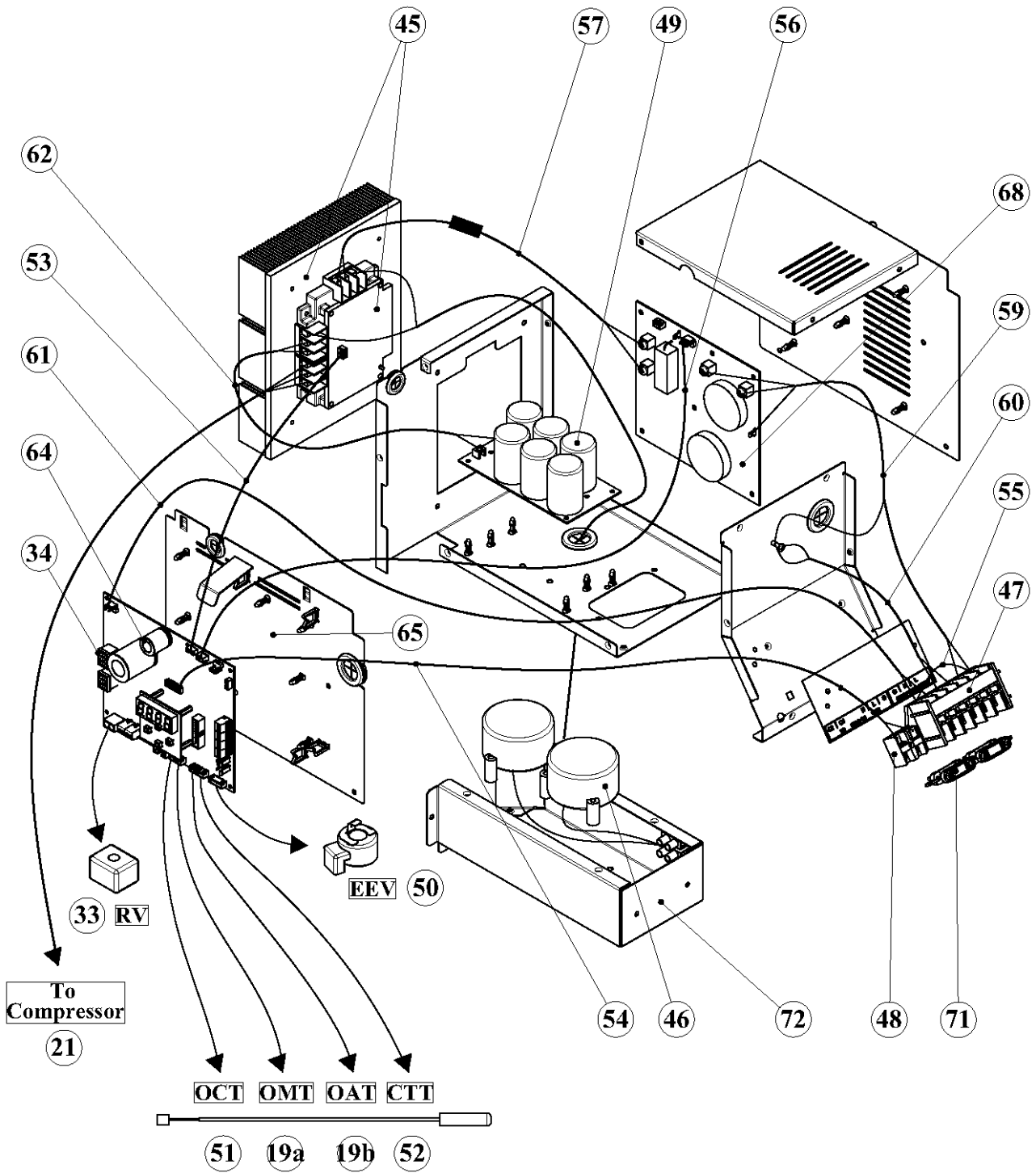

15.11 Outdoor Unit: GC 36 DCI - Spare Part List

No.	PN	Description	Qty
1	437045	UPPER COVER EL13 OU LARGE	1
2	416217	SIDE PANEL OU12 DCI 4-5HP	1
3	436356	LARGE ELECTRICAL COVER OU/WMQ	1
4	416215	FRONT COVER OU12 DCI 4-5HP	1
4a	416216	FRONT Panel OU12 DCI 4-5HP	1
5	437091	OU SQUARE FAN GUARD	2
6	416213	NEW BASE ASSY OU12 DCI 4-5HP	1
7	416400	LOWER COIL GR HDR OU12 DCI R41	1
7a	416401	UPPER COIL GR HDR OU12 DCI R41	1
8	4529604	AXIAL FAN D493*143	2
9	416310	DC MOTOR 70W OU12 DCI 4-5HP	2
10	416218	SIDE GUARD OU12 DCI 4-5HP	1
11	436358	OU LEADING HANDLE	1
12	416222	MOTOR SUPPORT ASSEMBLY OU12-DC	1
14	416300	COMPRESSOR ANB33FBDMT	1
15	416534	Tubing Assembly EEV OU12 DCI	1
16	416543	Tubing Assembly 4-Way GC 36 DCI	1
19a	413712	THERMISTOR+CAP WITH CONNECTOR	1
19b	402741	THERMISTOR WTH CONNECTOR L1250	1
21	416760	COMPRESSOR WIRING L1300	1
22	402284	SUCTION ACCUMULATOR 5" x 3/4"	1
23	439928	OUTLET PLASTIC RING OU8	2
26	436352	RAISING HANDLE OU10	2
31	416230	ELECTRONICS BOX DCI 4-5HP	1
33	442466	VALVE COIL L700 MOLEX-SANHUA	1
34	416712	DCI 456 HP ODU Main Board (SPL)	1
37	416740	HP Switch 4.2/3.7 Mpa(g)	1
42	416550	EEV Assembly GC 36 / 43 DCI (SPL)	1
43	416602	COMPRESSOR INSULATION DCI 4-5HP Assembly (SPL)	1
45	416711	DRIVER 4-5HP DCI Assembly (SPL)	1
46	416715	PFC Chocks 4-5HP	2
47	416724	Terminal Block 6P	1
48	416726	Terminal block 2P DCI	1
49	416713	456 HP ODU Capacitor Board (SPL)	1
50	416730	EEV COIL VKV MOZS348E0	1
51	416751	OCT-THERMISTOR+CAP WTH CONNECT	1
52	416752	CTT-THERMISTOR+CAP WTH CONNECT	1
53	416762	Cable Driver Communication	1
54	416763	Cable IDU Communication	1
55	416764	CABLE INDOOR INPUT	1
56	416766	Cable Inrush Communication	1
57	416767	Cable Line filter-Driver	1
59	416769	Cable Terminals-Line filter	1
60	416770	Cable Terminal Ground	1
61	416774	CABLE CONTROLLER INPUT -OUT	1
62	416776	CABLE CAPACITOR DRIVER (EHK)	1
64	416906	*P.C SPACER RS-10	21
65	416910	CABLE HOLDER KWS-1	4
68	416714	456 HP ODU Filter Board (SPL)	1
69	416542	Tubing Assembly LIQUID VALVE O	1
70	416921	TERMINAL COVER DCI MITSUBISHI	1
71	438551	SUPPLY CORD CLAMP 20mm	2
72	762245	TERMINAL BLOCK N0.3	2/12

15.12 Outdoor Unit: GC 43 DCI - Spare Part List

No.	PN	Description	Qty
1	437045	UPPER COVER EL13 OU LARGE	1
2	416217	SIDE PANEL OU12 DCI 4-5HP	1
3	436356	LARGE ELECTRICAL COVER OU/WMQ	1
4	416215	FRONT COVER OU12 DCI 4-5HP	1
4a	416216	FRONT Panel OU12 DCI 4-5HP	1
5	437091	OU SQUARE FAN GUARD	2
6	416213	NEW BASE ASSY OU12 DCI 4-5HP	1
7	416400	LOWER COIL GR HDR OU12 DCI R41	1
7a	416401	UPPER COIL GR HDR OU12 DCI R41	1
8	4529604	AXIAL FAN D493*143	2
9	416310	DC MOTOR 70W OU12 DCI 4-5HP	2
10	416218	SIDE GUARD OU12 DCI 4-5HP	1
11	436358	OU LEADING HANDLE	1
12	416222	MOTOR SUPPORT ASSEMBLY OU12-DC	1
14	416300	COMPRESSOR ANB33FBDMT	1
15	416534	Tubing Assembly EEV OU12 DCI	1
16	416527	Tubing Assembly 4-Way GC 43 DCI	1
19a	413712	THERMISTOR+CAP WITH CONNECTOR	1
19b	402741	THERMISTOR WTH CONNECTOR L1250	1
21	416760	COMPRESSOR WIRING L1300	1
22	402284	SUCTION ACCUMULATOR 5" x 3/4"	1
23	439928	OUTLET PLASTIC RING OU8	2
26	436352	RAISING HANDLE OU10	2
31	416230	ELECTRONICS BOX DCI 4-5HP	1
33	442466	VALVE COIL L700 MOLEX-SANHUA	1
34	416712	DCI 456 HP ODU Main Board (SPL)	1
37	416740	HP Switch 4.2/3.7 Mpa(g)	1
42	416550	EEV Assembly GC 36 / 43 DCI (SPL)	1
43	416602	COMPRESSOR INSULATION DCI 4-5HP Assembly (SPL)	1
45	416711	DRIVER 4-5HP DCI Assembly (SPL)	1
46	416715	PFC Chocks 4-5HP	2
47	416724	Terminal Block 6P	1
48	416726	Terminal block 2P DCI	1
49	416713	456 HP ODU Capacitor Board (SPL)	1
50	416730	EEV COIL VKV MOZS348E0	1
51	416751	OCT-THERMISTOR+CAP WTH CONNECT	1
52	416752	CTT-THERMISTOR+CAP WTH CONNECT	1
53	416762	Cable Driver Communication	1
54	416763	Cable IDU Communication	1
55	416764	CABLE INDOOR INPUT	1
56	416766	Cable Inrush Communication	1
57	416767	Cable Line filter-Driver	1
59	416769	Cable Terminals-Line filter	1
60	416770	Cable Terminal Ground	1
61	416774	CABLE CONTROLLER INPUT -OUT	1
62	416776	CABLE CAPACITOR DRIVER (EHK)	1
64	416906	*P.C SPACER RS-10	21
65	416910	CABLE HOLDER KWS-1	4
68	416714	456 HP ODU Filter Board (SPL)	1
69	416542	Tubing Assembly LIQUID VALVE O	1
70	416921	TERMINAL COVER DCI MITSUBISHI	1
71	438551	SUPPLY CORD CLAMP 20mm	2
72	762245	TERMINAL BLOCK NO.3	2/12

15.13 GC 60 DCI - Exploded View

15.13.1 Outdoor Unit General Assembly

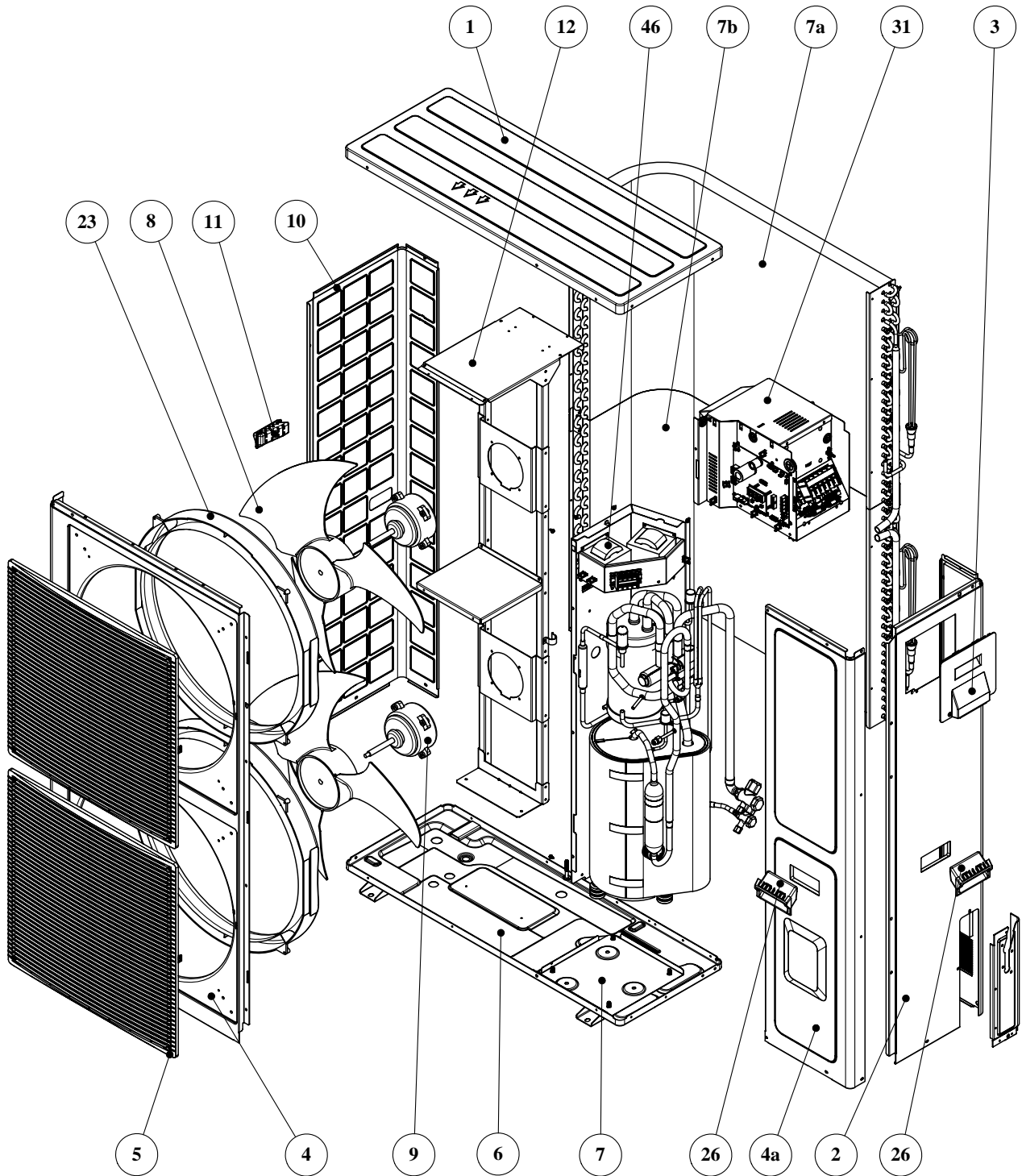

15.13.2 Outdoor Unit Tubing Assembly

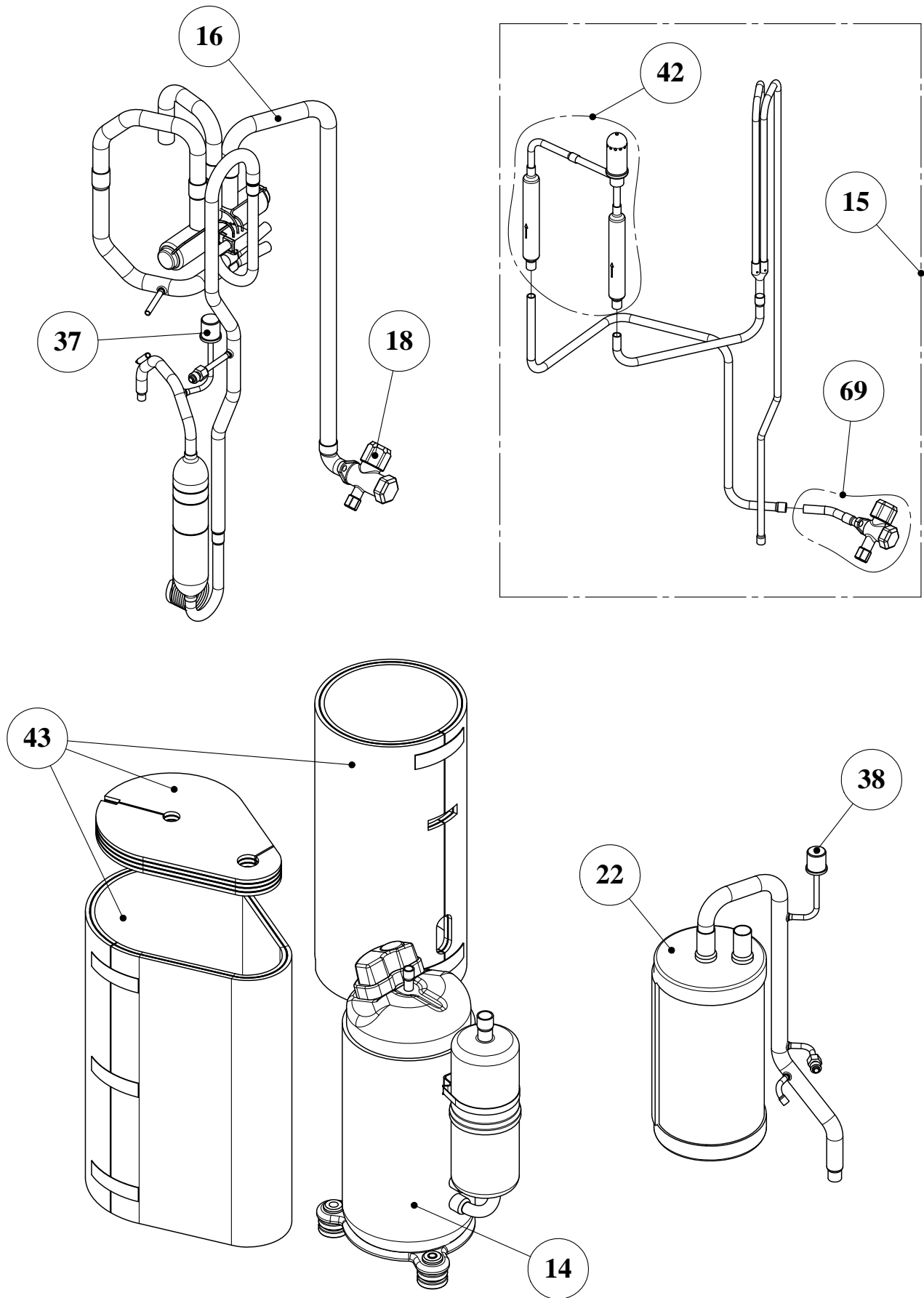

15.13.3 Outdoor Unit Electronics Assembly

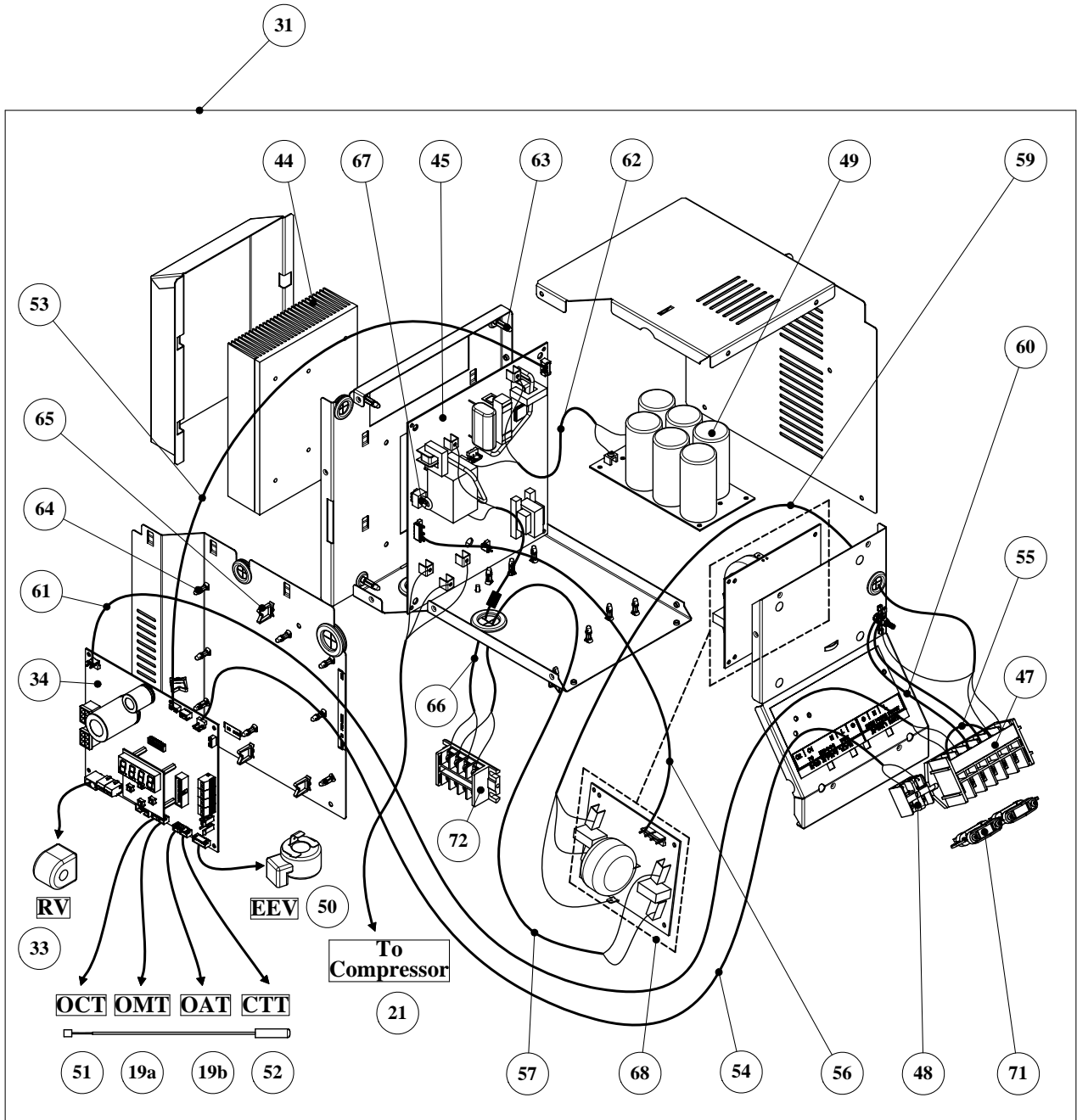

15.13.4 Outdoor Unit Spare Part List

No.	Item	Description	Quantity
1	416246	UPPER COVER ASSY OU12 DCI 4-5H	1
2	417218	SIDE PANEL ASSY GC 60 DCI	1
3	436356	LARGE ELECTRICAL COVER OU/WMQ	1
4	416215	FRONT COVER OU12 DCI 4-5HP	1
4a	417219	FRONT PANEL ASSY GC 60 DCI	1
5	437091	OU SQUARE FAN GUARD	2
6	417200	NEW BASE ASSY GC 60 DCI	1
7	417201	Compressor Base Plate ASSY OU1	1
7a	417401	UPPER COIL GR HDR GC 60 DCI	1
7b	417400	LOWER COIL GR HDR GC 60 DCI	1
8	4529604	AXIAL FAN D493*143	2
9	416310	DC MOTOR 70W OU12 DCI 4-5HP	2
10	416218	SIDE GUARD OU12 DCI 4-5HP	1
11	436358	OU LEADING HANDLE	1
12	416222	MOTOR SUPPORT ASSEMBLY OU12-DC	1
14	417300	COMPRESSOR DA420A3F-20M	1
15	417528	Tubing Assembly GC 60 DCI	1
16	417518	Tubing Assembly GC 60 DCI	1
18	434549	SERVICE VALVE ASSY 3/4F 3 WAY R410A	1
19a	413712	THERMISTOR+CAP WITH CONNECTOR	1
19b	402741	THERMISTOR WTH CONNECTOR L1250	1
21	416760	COMPRESSOR WIRING L1300	1
22	402284	SUCTION ACCUMULATOR 5" x 3/4"	1
23	439928	OUTLET PLASTIC RING OU8	2
26	436352	RAISING HANDLE OU10	1
26	436352	RAISING HANDLE OU10	1
31	417230	CONTROLLER ASSEMBLY DCI 6HP	1
33	442466	VALVE COIL L700 MOLEX-SANHUA	1
34	417713	DCI 6 HP ODU Main Board ASSY	1
37	416740	HP Switch 4.2/3.7 Mpa(g)	1
38	417742	LP Switch 0.15/0.2 Mpa(g)	1
42	417531	EEV Assembly GC 60 DCI	1
43	417603	COMPRESSOR INSULATION DCI 6HP	1
44	417711	HS DCI 6HP COATED	1
45	417712	DRIVER 6HP DCI Assembly	1
46	417715	PFC Chocks 6HP	2
47	416724	Terminal Block 6P	1
48	416726	Terminal block 2P DCI	1
49	417714	6 HP ODU Capacitor Board ASSY	1
50	416730	EEV COIL VKV-MOZS330E0(N-KV-13	1
51	416751	OCT-THERMISTOR+CAP WTH CONNECT	1
52	416752	CTT-THERMISTOR+CAP WTH CONNECT	1
53	417781	Cable Driver Communication	1
54	416763	Cable IDU Communication	1
55	416764	CABLE INDOOR INPUT	1
56	417782	CABLE ZERO CROSS	1
57	417784	CABLE LF-CHOCK	1
59	417785	Cable Terminals-Line filter	1
60	416770	Cable Terminal Ground	1
61	416774	CABLE CONTROLLER INPUT -OUT	1
62	417783	CABLE CAPS DRIVER	1
63	417914	P.C SPACER RS-14	4
64	416906	P.C SPACER RS-10	4
65	416910	CABLE HOLDER KWS-1	4
66	417787	CABLE DRIVER-CHOCK	1
67	417788	Cable Thermo Switch Shorted	1
68	417716	6 HP ODU Filter Board ASSY	1
69	416542	Tubing Assembly LIQUID VALVE O	1
71	438551	SUPPLY CORD CLAMP 20mm	2
72	417720	Terminal Block 4P	1

16. OPTIONAL ACCESSORIES

16.1 RCW Wall Mounted Remote Control

16.1.1 The RCW wall mounted remote control can be fitted to a large range and models, It can be used as IR (wirless mode) or wired controler.the RCW can control up to15 indoor units using the same settings (on its wired aplication).

The max wiring length between the controller to the last indoor unit is 300m. for application on WNG LED indoor units an additional interface PCB is needed.

Ordering code no':

RCW – 436195

WNG add' PCB - SP000000290.

REMOTE CONTROL

1. START / STOP button
2. Operation mode selection button COOLING, HEATING, AUTO COOL / HEAT, DRY, FAN.
3. LOCAL temperature sensing button
4. FAN SPEED and AUTO FAN button
5. Room temperature UP button
6. Room temperature DOWN Button
7. NIGHT button
8. Airflow direction MANUAL positioning cor
9. Airflow direction AUTO-CONTROL button
10. TIMER button
11. TIMER UP button
12. TIMER DOWN button
13. LCD operation display
14. LOCAL sensor
15. Infrared signal transmitter
16. ROOM temperature button
17. TIMER SET button
18. TIMER CLEAR button
19. Transmission sign

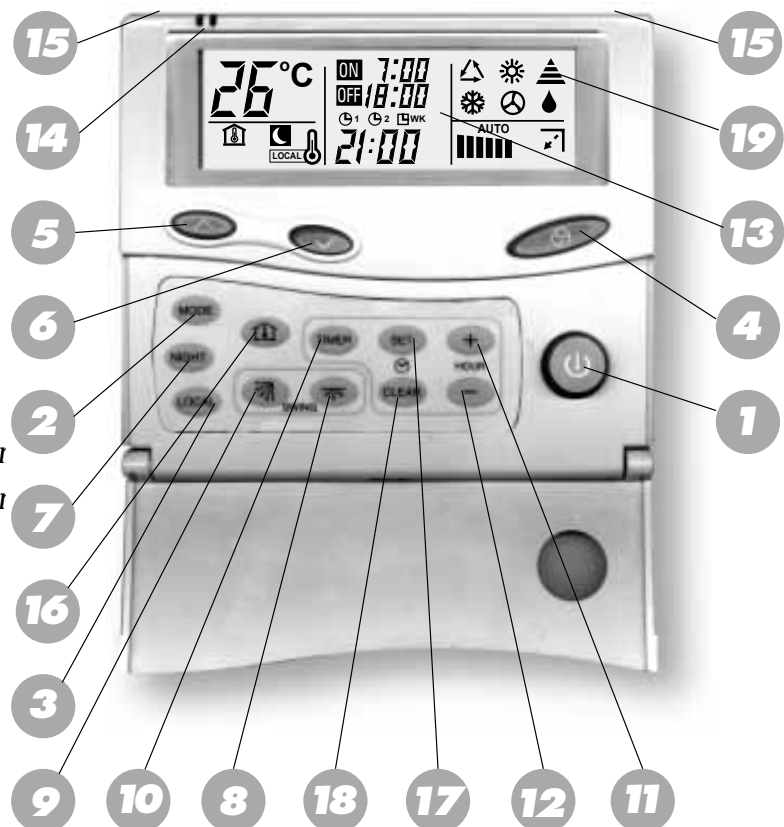

16.2 RCW2 Wall Mounted Remote Control

16.2.1 The RCW2 wall mounted remote controller is a wired controller that can provide effective controlling management up to 15 different settings and temp' zones.

The RCW2 can be connected up to a max' of 32 units, allowing a max wiring length of 1000m for application on WNG LED indoor units an additional interface PCB is needed.

Ordering code no':

RCW2 – SP000000081

WNG add' PCB - SP000000290

1 Display screen.

2 Keys for raising and lowering the set temperature.

3 Ventilation mode selection :

- ▄▄▄ Low speed.
- ▄▄▄▄ Medium speed.
- ▄▄▄▄▄ High speed.

AUTO : Automatic speed selection.

4 ON / Standby.

(SET) Accessing the time setting mode.

(+) Advancing the time setting.

(-) Retarding the time setting.

(CLEAR) Clearing memory of programmed time settings in programming mode.

(LOCAL DAY) Day of the week selection key or sending "I feel" local temperature setting.

(PROG) Programming mode key.

(COPY) "Copy" key, enabling zone parameters to be duplicated for other zones.

(MODE) Operating mode selection.

(NIGHT) Day /Night key.

(▲) Current zone setting: zone above.

(▼) Current zone setting: zone below.

(SWING) Louver : step by step or horizontal.

(VERT) Louver : vertical.

1 Display screen.

2 Keys for raising and lowering the set temperature.

3 Ventilation mode selection :

- ▄▄▄ Low speed.
- ▄▄▄▄ Medium speed.
- ▄▄▄▄▄ High speed.

AUTO : Automatic speed selection.

4 ON / Standby.

(SET) Accessing the time setting mode.

(+) Advancing the time setting.

(-) Retarding the time setting.

(CLEAR) Clearing memory of programmed time settings in programming mode.

(LOCAL DAY) Day of the week selection key or sending "I feel" local temperature setting.

(PROG) Programming mode key.

(COPY) "Copy" key, enabling zone parameters to be duplicated for other zones.

(MODE) Operating mode selection.

(NIGHT) Day /Night key.

(▲) Current zone setting: zone above.

(▼) Current zone setting: zone below.

(SWING) Louver : step by step or horizontal.

(VERT) Louver : vertical.

16.3 Base Heater

PN: 439878

Before starting the heaters connection verify that the unit is disconnected from main power supply!!

BASE HEATERT INSTALLATION INSTRUCTIONS

Check the installation manual for further information

The kit includes:

1. One 70W PT heating element.
2. One Heater holder.
3. Two magnets for assemble of heater to outdoor base.
4. 4 Strips.

Instructions:

1. Open the outdoor unit electrical cover and service panel.
2. Connect the base heater wires to connections marked as "BH" on the main controller (refer to Figure 1).
3. Route the wires into the cable holders and through the grommet and attach the wires with strips to other wires as per Figure 1 & 2.
4. Locate the heater under the outdoor base with the magnets according to Figure 3.
5. Attach with strips the wires to the pipes and the base unit.
6. Close the outdoor electrical cover and service panel.

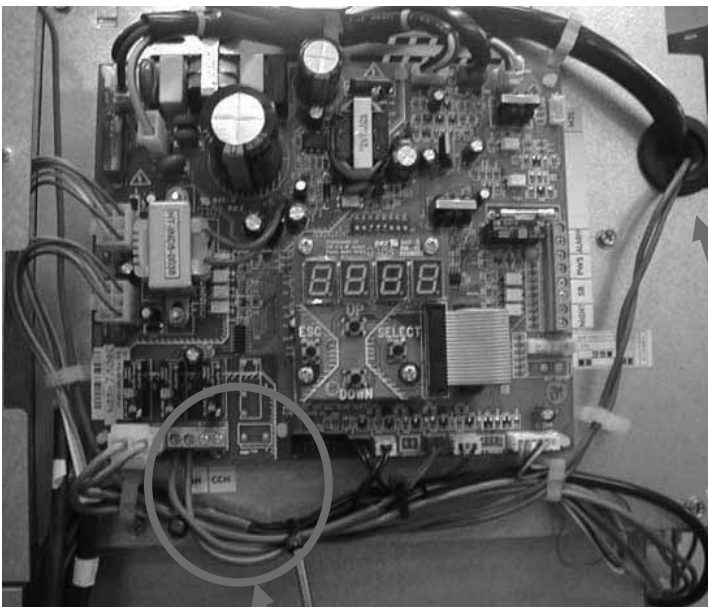

Figure 1

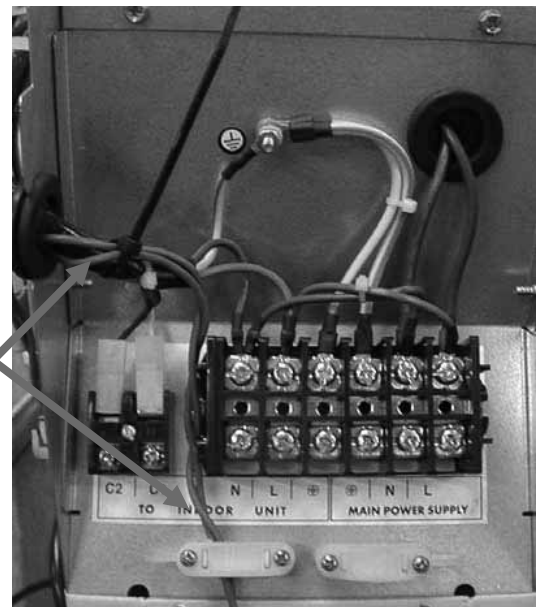
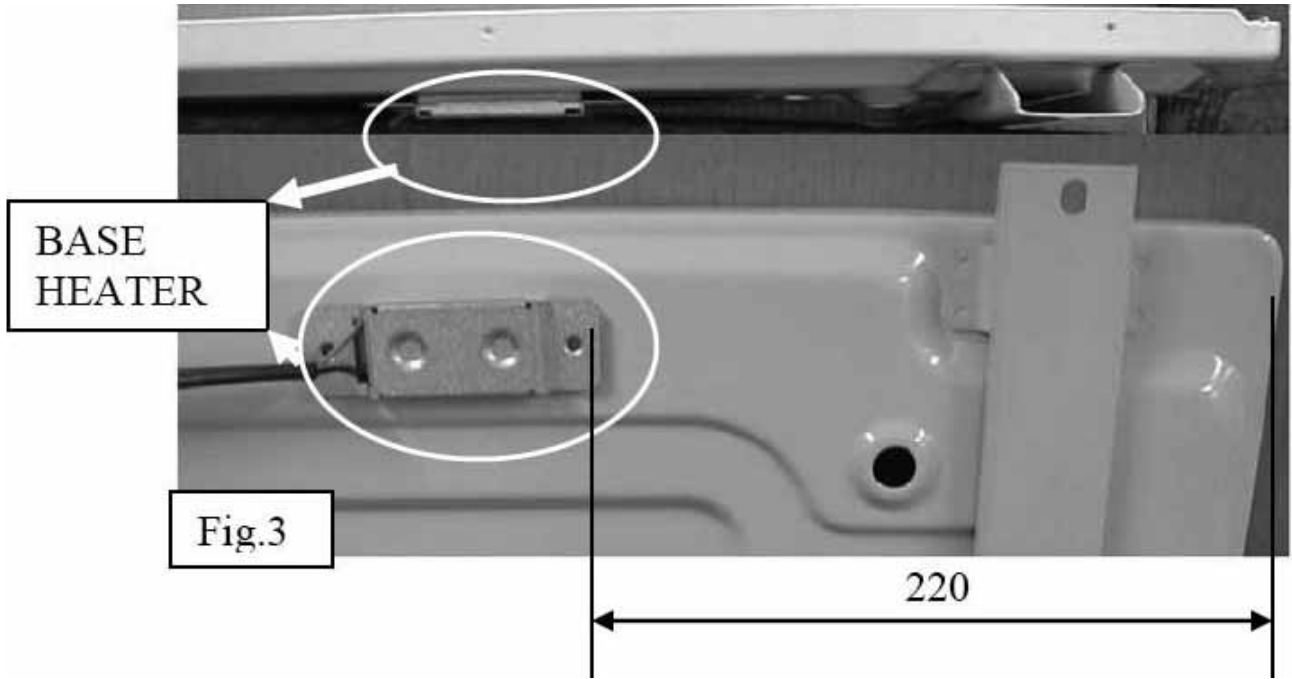

Figure 2



16.4 Crank Case Heater

PN: 190443

Before starting the heaters connection verify that the unit is disconnected from main power supply!!

CRANK CASE HEATERS INSTALLATION INSTRUCTIONS

Check the installation manual for further information

The kit includes:

1. One 50W heating element.
2. One spring holder.

Instructions:

1. Open the outdoor unit electrical cover and service panel.
2. Remove the compressor insulation layers.
3. Locate the heater around the compressor and close with the spring according to Figure 1.
4. Route the wires into the cable holders as per Figure 2.
5. Connect the heater wires to connections marked as "CCH" on the main controller (refer to Figure 3).
6. Attach the wires with strips to other wires as per Figure 3.
7. Put back the compressor insulation layers.
8. Close the outdoor electrical cover and service panel.



Figure 1

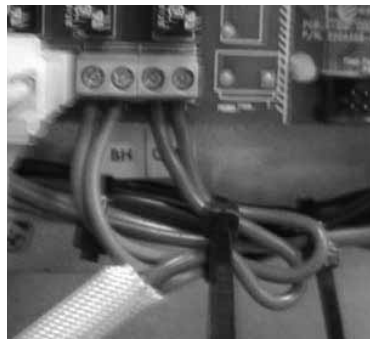

Figure 3



Figure 2

16.5 Room Thermostat

Room Thermostat kit PN: 442298
 Thermistor with connector PN: 442296

Before starting the connection verify that the unit is disconnected from main power supply!!

ROOM THERMOSTAT INSTALLATION INSTRUCTIONS

Check the installation manual for further information

Supplied components list:

No.	Item	QTY	PN
1	Thermostat box	1	442298
2	Shielded cable	1	
3	Screws and plugs	2	
4	LABEL	1	
5	BAG	1	

1	Extension cable with connector	1	442296
---	--------------------------------	---	--------

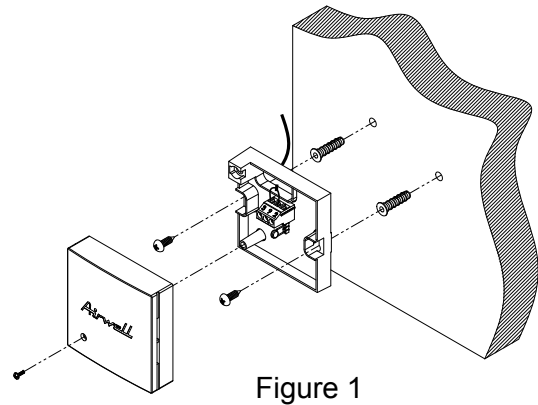

Figure 1

Choosing location of installation:

- Away from air drafts
- Away from direct sun light rays
- Average height – 1.5 meters above floor
- Away from any heat source

1. Install the thermostat box on the wall according the above location preferences. See figure 1.
2. Connect the shielded cable supplied to the thermostat box into points 3 and 9 (non polarity).
3. Disconnect the existing “RM” sensor from the indoor unit main controller.
4. Connect the other end of “RM” extension cable to the the sheilded cable. Also connect the grounding fork terminal into the grounding terminal point.
5. In the indoor unit main controller, move the dip switch #2 to OFF position.

APPENDIX A

INSTALLATION AND OPERATION MANUALS

- ▶ **INSTALLATION INSTRUCTION DLS DCI**
- ▶ **INSTALLATION INSTRUCTION DHC DCI**
- ▶ **INSTALLATION INSTRUCTION CD DCI**
- ▶ **INFRARED REMOTE CONTROL RECEIVER**
- ▶ **OPERATION MANUAL RC-3**
- ▶ **OPERATION MANUAL RC-4**
- ▶ **OPERATION MANUAL RC-7**