

Airwell

Service Manual

Multi Split Trio Quattro DCI

Indoor Units	Outdoor Units
FLO 9 DCI	TRIO-72 DCI QUATTRO-80 DCI
FLO 12 DCI	
FLO 18 DCI	
SX 9 DCI	
SX 12 DCI	
SX 18 DCI	
BS 12 DCI	
K 9 DCI	
K 12 DCI	
K 18 DCI	



REFRIGERANT

R410A

HEAT PUMP

SM TQDCI 1-A.1 GB

OCTOBER – 2008

LIST OF EFFECTIVE PAGES

Note: Changes in the pages are indicated by a “Revision#” in the footer of each effected page (when none indicates no changes in the relevant page). All pages in the following list represent effected/ non effected pages divided by chapters.

Dates of issue for original and changed pages are:

Original 0 June 2005

Total number of pages in this publication is **107** consisting of the following:

Page No.	Revision No. #		Page No.	Revision No. #		Page No.	Revision No. #
----------	----------------	--	----------	----------------	--	----------	----------------

Title 1
 A 1
 i 1
 1-1 - 1-4 1
 2-1 - 2-4 1
 3-1 - 3-2 1
 4-1 - 4-2 1
 5-1 - 5-10 1
 6-1 - 6-2 1
 7-1 - 7-2 1
 8-1 - 8-2 1
 9-1 - 9-2 1
 10-1-10-2 1
 11-1-11-18 1
 12-1-12-6 1
 13-1-13-2 1
 Appendix -A 1

- Zero in this column indicates an original page.

*Due to constant improvements please note that the data on this service manual can be modified with out notice.

**Photos are not contractual

Table of Contents

1.	INTRODUCTION	1-1
2.	PRODUCT DATA SHEET	2-1
3.	RATING CONDITIONS	3-1
4.	OUTLINE DIMENSIONS	4-1
5.	PERFORMANCE DATA	5-1
6.	PRESSURE CURVES	6-1
7.	ELECTRICAL DATA.....	7-1
8.	WIRING DIAGRAMS & ELECTRICAL CONNECTIONS	8-1
9.	REFRIGERATION DIAGRAMS	9-1
10.	TUBING CONNECTIONS.....	10-1
11.	CONTROL SYSTEM	11-1
12.	TROUBLESHOOTING	12-1
13.	EXPLODED VIEWS AND SPARE PARTS LISTS.....	13-1
14.	APPENDIX A	14-1

1. INTRODUCTION

1.1 General

The **Trio/Quattro DCI Multi series** is a full line multi-tubing system with 3 to 4 connected indoor units. The multi-split inverter is a high level technology product for residential and commercial application offering comfort, low noise operation and energy saving.

1.2 Main Features

1.2.1 High Technology

- Sine wave form in both OFAN and Compressor drives.
- DC-BL-SL (Sensor less) Inverter Compressor drive.
- DC-BL Inverter OFAN drive in the controller.
- DSP Power (Digital Signal Processing) – High speed calculation for accurate Sine wave form vector control.
- Smart PFC control.
- Fuzzy Logic Control

1.2.2 System Features

- R410A
- High COP (“A” class energy rating)
- Low noise level
- IAQ (Indoor Air Quality) features (FLO series)
- Lego concept - Products line of wall mounted, floor/ceiling, cassette, ducted with capacity mode of 2.5, 3.5 and 5.0 kW.
- Networking connectivity.
- Pre-charged system.
- Dry contact inputs:
 - STBY
 - Night (in cool mode only)
 - Power Shedding
 - Forced Mode operation
- Dry contact output – Alarm.
- Ready for Base heater connection and logic.
- Cooling operation at outdoor temperature down to -10°C.
- Heating operation at outdoor temperature down to -15°C.
- HMI Display Board (Human-Machine Interface) – 3x7-segment display shows both indoor and outdoor diagnostics and setting up features.
- Monitoring software (PC port).
- EEV (Electronic Expansion Valve) for each indoor unit.

1.3 Tubing Connections



Flare type interconnecting tubing to be produced on site.

For further details please refer to APPENDIX A on this manual, and to the relevant indoor service Manual.

1.4 Inbox Documentation

Each indoor unit is supplied with its own installation and operation manual.

1.5 Matching Table R410A

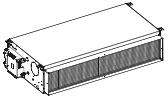
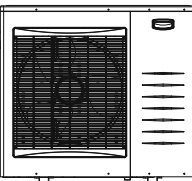
OUTDOOR UNITS			DCI INDOOR UNITS			
						
	MODEL	REFRIGER.	FLO 9/12/18	K 9/12/18	SX 9/12/18	BS 12
	Trio-72 DCI	R410A	√	√	√	√
	Quattro-80 DCI	R410A	√	√	√	√

1.6 Indoor Unit combinations

Trio				Quattro				
Unit A	Unit B	Unit D	Code Sum	Unit A	Unit B	Unit C	Unit D	Code Sum
9	9	9	3	9	9	9	9	4
9	9	12	3.5	9	9	9	12	4.5
9	9	18	4	9	9	12	12	5
9	12	12	4	9	9	9	18	5
12	12	12	4.5	9	9	12	18	5.5
12	12	18	4.5	9	12	12	12	5.5
12	12	18	5	9	12	12	18	6
				12	12	12	12	6

 Nominal Indoor Units Combination

2. PRODUCT DATA SHEET

2.1 Outdoor TRIO-72 DCI Specifications.

Model			TRIO-72 DCI R410A			
Operation Mode			Cooling	Heating		
Capacity ^{(1), (2)}		Kcal/hr	6,190(1,120~7,740)	7,740 (820~9,460)		
		Btu/hr	24,570(4,440~30,710)	30,710 (3,240~37,530)		
		W	7,200 (1,300~9,000)	9,000 (950~11,000)		
Total Input			W	2,240 (500~3,000) 2,370 (500~3,000)		
E.E.R (Cooling) / C.O.P (Heating)			W/W	3.21 3.80		
Running Current ⁽³⁾			A	9.7 9.8		
Starting Current			A	10		
Inrush Current			A	<35.0		
Power Supply			V/Ph/Hz	220-240V/ 1PH / 50Hz		
OUTDOOR UNIT	Refrigerant control		Electronic expansion valve			
	Compressor type		Twin Rotary DC Inverter			
	Model		MELCO TNB220FLBM			
	Starter type		---			
	Protection device		Outdoor SW control			
	Heat exchanger		Hydrophilic corrugated fins ,Grooved tubes			
	Fan x No.		Propeller x 1			
	Airflow		m ³ /hr	3,200		
	Motor output		W	90		
	Defrost method		Reverse cycle			
	Noise level ⁽⁴⁾	Pressure	dB(A)	53	54	
		Power		63	64	
	Dimensions	W*D*H	mm	950*835*340		
	Weight		Kg	69		
	Package	W*D*H	mm	1,070X510X940		
	Unit stacking		#	3		
TUBING	Refrigerant Charge		Kg	R410A - 3,200		
	Tube size O.D.	Liquid	mm	3x 6.35		
		Suction	mm	2x 9.53 + 1x 12.7		
	Connection method between the indoor and outdoor units	Indoor & outdoor		Flared		
		Height difference between indoor units		Max.15m		
		Height difference between indoor & outdoor		Max.15m		
		Tubing length		Max.25m for one unit and 50m total		
Additional charge		No need				

Note:

- (1) Rating conditions in accordance with ISO 5151 and ISO 13253 (for ducted units).
- (2) Nominal capacity is measured with the combination of 4x FLO 25 DCI (Quattro) or 3x FLO 25 DCI (Trio) and 5m tubing each unit. Maximum capacity is measured with the combination of FLO 25 DCI + 2x FLO 35 DCI + FLO 50 DCI (Quattro) or 2x FLO 35 DCI + FLO 50 DCI (Trio) and 5m tubing each unit. Minimum capacity is measured with FLO 25 DCI (Quattro/Trio) and 5m tubing.
- (3) Running Current is measured in nominal conditions at 230V.
- (4) Sound pressure level measured at 1 meter distance from unit at nominal (cool/heat) conditions

2.2 Outdoor QUATTRO-80 DCI Specifications.

Model			QUATTRO-80 DCI R410A			
Operation Mode			Cooling	Heating		
Capacity ^{(1), (2)}	Kcal/hr		6,880 (1,200~7,910)	8,170 (820~9,460)		
	Btu/hr		27,300 (4,780~31,390)	32,410 (3,240~37,530)		
	W		8,000 (1,400~9,200)	9,500 (950~11,000)		
Total Input	W		2,490 (500~3,000)	2,380 (400~3,000)		
E.E.R (Cooling) / C.O.P (Heating)	W/W		3.21	4.00		
Running Current ⁽³⁾	A		10.8	10.3		
Starting Current	A		11			
Inrush Current	A		<35.0			
Power Supply	V/Ph/Hz		220-240V/ 1PH / 50Hz			
OUTDOOR UNIT	Refrigerant control		Electronic expansion valve			
	Compressor type		Twin Rotary DC Inverter			
	Model		MELCO TNB220FLBM			
	Starter type		---			
	Protection device		Outdoor SW control			
	Heat exchanger		Hydrophilic corrugated fins ,Grooved tubes			
	Fan x No.		Propeller x 1			
	Airflow	m ³ /hr	3,200			
	Motor output	W	90			
	Defrost method		Reverse cycle			
	Noise level ⁽⁴⁾	Pressure	dB(A)	53	54	
		Power		63	64	
	Dimensions	W*D*H	mm	950*835*340		
	Weight		Kg	70		
	Package	W*D*H	mm	1,070X510X940		
Unit stacking			3			
TUBING	Refrigerant Charge		Kg	R410A - 3,400		
	Tube size O.D.	Liquid	mm	4x 6.35		
		Suction	mm	3x 9.53 + 1x 12.7		
	Connection method between the indoor and outdoor units	Indoor & outdoor		Flared		
		Height difference between indoor units		Max.15m		
		Height difference between indoor & outdoor		Max.15m		
		Tubing length		Max.25m for one unit and 70m total		
		Additional charge		No need		

Note:

- (1) Rating conditions in accordance with ISO 5151 and ISO 13253 (for ducted units).
- (2) Nominal capacity is measured with the combination of 4x FLO 25 DCI (Quattro) or 3x FLO 25 DCI (Trio) and 5m tubing each unit. Maximum capacity is measured with the combination of FLO 25 DCI + 2x FLO 35 DCI + FLO 50 DCI (Quattro) or 2x FLO 35 DCI + FLO 50 DCI (Trio) and 5m tubing each unit. Minimum capacity is measured with FLO 25 DCI (Quattro/Trio) and 5m tubing.
- (3) Running Current is measured in nominal conditions at 230V.
- (4) Sound pressure level measured at 1 meter distance from unit at nominal (cool/heat) conditions.

2.3 Indoor Units Data

2.3.1 FLO 9 DCI Specifications

Model Indoor Unit / Type				FLO 9 DCI / Wall Mounted		
Installation Method				FLARE		
Power Supply		V/Ph/Hz		220-240 / 1/ 50		
INDOOR	Fan Type & Quantity			Crossflow *1		
	Airflow ⁽²⁾ Cooling / Heating	H/M/L	m ³ /hr	530/570 430/460 330/350		
	Sound Power Level ⁽³⁾ Cooling / Heating	L - H	dB (A)	39-50 / 39-51		
	Sound Pressure Level ⁽⁴⁾ Cooling / Heating	L - H	dB (A)	26-38 / 26-39		
	Condensate Drain Tube I.D.		mm	16		
	Dimensions	W/H/D	mm	810	285	202
	Weight		kg	11		
	Package Dimensions	W/H/D	mm	885	360	285
	Stacking Height		Units	7		
	Heating Elements			kW		N/A
Moisture Removal			L/hr		1	

2.3.2 FLO 12 DCI Specifications

Model Indoor Unit / Type				FLO 12 DCI / Wall Mounted		
Installation Method				FLARE		
Power Supply		V/Ph/Hz		220-240 / 1/ 50		
INDOOR	Fan Type & Quantity			Crossflow *1		
	Airflow ⁽²⁾ Cooling / Heating	H/M/L	m ³ /hr	550/580 450/480 350/370		
	Sound Power Level ⁽³⁾ Cooling / Heating	L - H	dB (A)	39-52 / 39-52		
	Sound Pressure Level ⁽⁴⁾ Cooling / Heating	L - H	dB (A)	26-39 / 26-40		
	Condensate Drain Tube I.D.		mm	16		
	Dimensions	W/H/D	mm	810	285	202
	Weight		kg	11		
	Package Dimensions	W/H/D	mm	885	360	285
	Stacking Height		Units	7		
	Heating Elements			kW		N/A
Moisture Removal			L/hr		1.5	

NOTE:

- 1) Rating conditions in accordance with ISO 5151 and ISO 13253 (for ducted units) and EN14511.
- (2) Airflow in ducted units; at nominal external static pressure.
- (3) Sound power in ducted units is measured at air discharge.
- (4) Sound pressure level measured at 1 meter distance from unit.

2.3.3 FLO 18 DCI Specifications

Model Indoor Unit / Type				FLO 18 DCI / Wall Mounted			
Installation Method				FLARE			
Power Supply		V/Ph/Hz		220-240 / 1/ 50			
INDOOR	Fan Type & Quantity			Crossflow *1			
	Airflow ⁽²⁾ Cooling / Heating		H/M/L	m ³ /hr	850	760	620
	Sound Power Level ⁽³⁾		L - H	dB (A)	47 - 55		
	Sound Pressure Level ⁽⁴⁾		L - H	dB (A)	34 -43		
	Condensate Drain Tube I.D.			mm	16		
	Dimensions		W/H/D	mm	1060	295	210
	Weight			kg	15		
	Package Dimensions		W/H/D	mm	1125	360	280
	Stacking Height			Units	8		
Heating Elements			kW	N/A			
Moisture Removal			L/hr	2			

2.3.4 K 9 DCI Specifications

Model Indoor Unit / Type				K 9 DCI / Cassette			
Installation Method				FLARE			
Power Supply		V/Ph/Hz		220-240 / 1/ 50			
INDOOR	Fan Type & Quantity			Centifugal *1			
	Airflow ⁽²⁾ Cooling / Heating		H/M/L	m ³ /hr	530/600	500/530	435/450
	Sound Power Level ⁽³⁾ Cooling / Heating		L - H	dB (A)	42-48 / 42-47		
	Sound Pressure Level ⁽⁴⁾ Cooling / Heating		L - H	dB (A)	32-38 / 32-37		
	Condensate Drain Tube I.D.			mm	16		
	Dimensions		W/H/D	mm	571	287	571
	Weight			kg	22.7		
	Package Dimensions		W/H/D	mm	685	415	685
	Stacking Height			Units	5		
Heating Elements			kW	N/A			
Moisture Removal			L/hr	1			

NOTE:

- 1) Rating conditions in accordance with ISO 5151 and ISO 13253 (for ducted units) and EN14511.
- (2) Airflow in ducted units; at nominal external static pressure.
- (3) Sound power in ducted units is measured at air discharge.
- (4) Sound pressure level measured at 1 meter distance from unit.

2.3.5 K 12 DCI Specifications

Model Indoor Unit / Type				K 12 DCI / Cassette		
Installation Method				FLARE		
Power Supply		V/Ph/Hz		220-240 / 1/ 50		
INDOOR	Fan Type & Quantity			Centifugal *1		
	Airflow ⁽²⁾ Cooling / Heating	H/M/L	m ³ /hr	580/620	510/560	435/450
	Sound Power Level ⁽³⁾ Cooling / Heating	L - H	dB (A)	42-49 / 42-48		
	Sound Pressure Level ⁽⁴⁾ Cooling / Heating	L - H	dB (A)	32-38 / 32-38		
	Condensate Drain Tube I.D.			mm		
	Dimensions			W/H/D	mm	571 287 571
	Weight			kg		
	Package Dimensions			W/H/D	mm	685 415 685
	Stacking Height			Units		
	Heating Elements			kW		
Moisture Removal			L/hr			

2.3.6 K 18 DCI Specifications

Model Indoor Unit / Type				K 18 DCI / Cassette		
Installation Method				FLARE		
Power Supply		V/Ph/Hz		220-240 / 1/ 50		
INDOOR	Fan Type & Quantity			Centifugal *1		
	Airflow ⁽²⁾	H/M/L	m ³ /hr	730	630	510
	Sound Power Level ⁽³⁾	L - H	dB (A)	46 - 59		
	Sound Pressure Level ⁽⁴⁾	L - H	dB (A)	36 – 48.5		
	Condensate Drain Tube I.D.			mm		
	Dimensions			W/H/D	mm	571 287 571
	Weight			kg		
	Package Dimensions			W/H/D	mm	685 415 685
	Stacking Height			Units		
	Heating Elements			kW		
Moisture Removal			L/hr			

NOTE

- 1) Rating conditions in accordance with ISO 5151 and ISO 13253 (for ducted units) and EN14511.
- (2) Airflow in ducted units; at nominal external static pressure.
- (3) Sound power in ducted units is measured at air discharge.
- (4) Sound pressure level measured at 1 meter distance from unit.

2.3.7 SX 9 DCI Specifications

Model Indoor Unit / Type				SX 9 DCI Floor/ceiling		
Installation Method				FLARE		
Power Supply		V/Ph/Hz		220-240 / 1/ 50		
INDOOR	Fan Type & Quantity			Centifugal *2		
	Airflow ⁽²⁾ Cooling / Heating	H/M/L	m ³ /hr	400	350	300
	Sound Power Level ⁽³⁾ Cooling / Heating	L - H	dB (A)	47-50		
	Sound Pressure Level ⁽⁴⁾ Cooling / Heating	L - H	dB (A)	39-35		
	Condensate Drain Tube I.D.		mm	16		
	Dimensions	W/H/D	mm	820	630	190
	Weight		kg	21		
	Package Dimensions	W/H/D	mm	890	710	280
	Stacking Height		Units	7		
	Heating Elements		kW	N/A		
Moisture Removal		L/hr	1			

2.3.8 SX 12 DCI Specifications

Model Indoor Unit / Type				SX 12 DCI Floor/ceiling		
Installation Method				FLARE		
Power Supply		V/Ph/Hz		220-240 / 1/ 50		
INDOOR	Fan Type & Quantity			Centifugal *2		
	Airflow ⁽²⁾ Cooling / Heating	H/M/L	m ³ /hr	450	400	300
	Sound Power Level ⁽³⁾ Cooling / Heating	L - H	dB (A)	51-56		
	Sound Pressure Level ⁽⁴⁾ Cooling / Heating	L - H	dB (A)	45 -38		
	Condensate Drain Tube I.D.		mm	16		
	Dimensions	W/H/D	mm	820	630	190
	Weight		kg	22		
	Package Dimensions	W/H/D	mm	890	710	280
	Stacking Height		Units	7		
	Heating Elements		kW	N/A		
Moisture Removal		L/hr	1.5			

NOTE:

- 1) Rating conditions in accordance with ISO 5151 and ISO 13253 (for ducted units) and EN14511.
- 2) Airflow in ducted units; at nominal external static pressure.
- 3) Sound power in ducted units is measured at air discharge.
- 4) Sound pressure level measured at 1 meter distance from unit.

2.3.9 SX 18 DCI Specifications

Model Indoor Unit / Type				SX 18 DCI Floor/ceiling		
Installation Method				FLARE		
Power Supply		V/Ph/Hz		220-240 / 1/ 50		
INDOOR	Fan Type & Quantity			Centifugal *2		
	Airflow ⁽²⁾ Cooling / Heating	H/M/L	m ³ /hr	870	750	600
	Sound Power Level ⁽³⁾ Cooling / Heating	L - H	dB (A)	56 - 65		
	Sound Pressure Level ⁽⁴⁾ Cooling / Heating	L - H	dB (A)	45 - 51		
	Condensate Drain Tube I.D.		mm	16		
	Dimensions	W/H/D	mm	1200	630	190
	Weight		kg	30		
	Package Dimensions	W/H/D	mm	1270	710	280
	Stacking Height		Units	7		
	Heating Elements		kW	N/A		
Moisture Removal		L/hr	2			

2.3.10 BS 12 DCI Specifications

Model Indoor Unit / Type				BS 12 DCI / Ducted		
Installation Method				FLARE		
Power Supply		V/Ph/Hz		220-240 / 1/ 50		
INDOOR	Fan Type & Quantity			Centifugal *2		
	Airflow ⁽²⁾ Cooling / Heating	H/M/L	m ³ /hr	590	50	400
	Sound Power Level ⁽³⁾ Cooling / Heating	L - H	dB (A)	52 - 59		
	Sound Pressure Level ⁽⁴⁾ Cooling / Heating	L - H	dB (A)	35 - 42		
	Condensate Drain Tube I.D.		mm	16		
	Dimensions	W/H/D	mm	860	245	680
	Weight		kg	30		
	Package Dimensions	W/H/D	mm	1055	305	728
	Stacking Height		Units	6		
	Heating Elements		kW	N/A		
Moisture Removal		L/hr	1.3			

NOTE:

- 1) Rating conditions in accordance with ISO 5151 and ISO 13253 (for ducted units) and EN14511.
- 2) Airflow in ducted units; at nominal external static pressure.
- 3) Sound power in ducted units is measured at air discharge.
- 4) Sound pressure level measured at 1 meter distance from unit.

3. RATING CONDITIONS

Standard conditions in accordance with ISO 5151, ISO 13253 (for ducted units) and EN 14511.

Cooling:

Indoor: 27°C DB 19°C WB

Outdoor: 35°C DB

Heating:

Indoor: 20°C DB

Outdoor: 7°C DB 6°C WB

3.1 Operating Limits

		Indoor	Outdoor
Cooling	Upper limit	32°C DB 23°C WB	46°C DB
	Lower limit	21°C DB 15°C WB	-10°C DB
Heating	Upper limit	27°C DB	24°C DB 18°C WB
	Lower limit	10°C DB	-15°C DB -16°C WB
Voltage	1PH	198 – 264 V	
	3PH	N/A	

4. OUTLINE DIMENSIONS

4.1 Indoor Unit: FLO 9/12 DCI

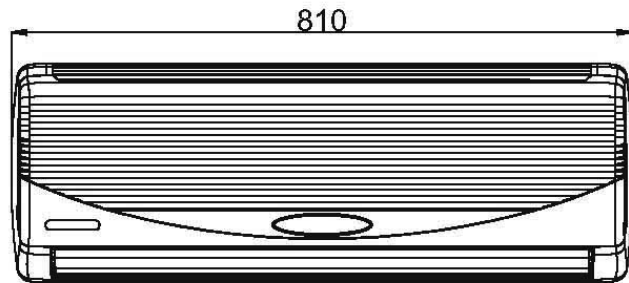
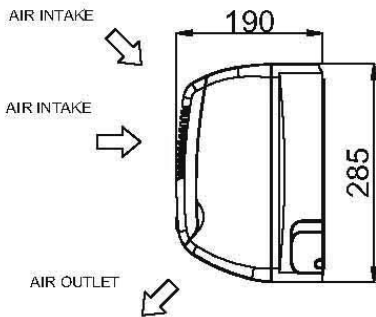
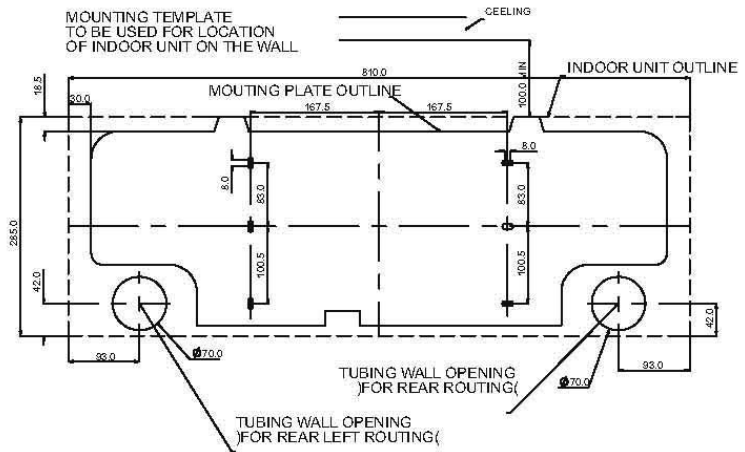

4.2 Indoor Unit: FLO 18 DCI

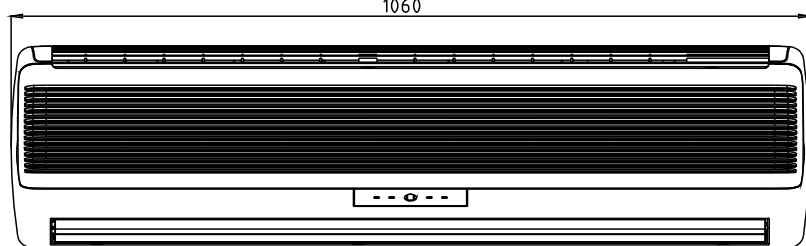
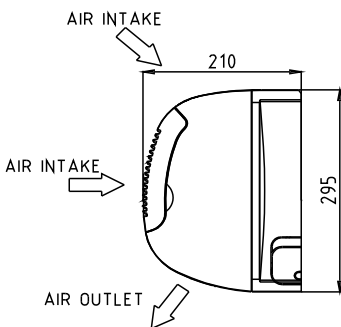
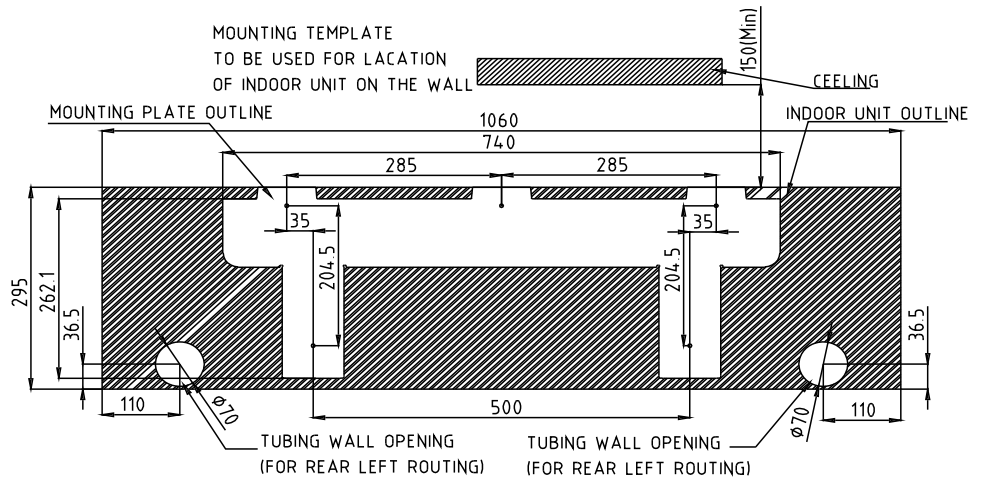

4.3 Indoor Unit: K 9, 12, 18 DCI

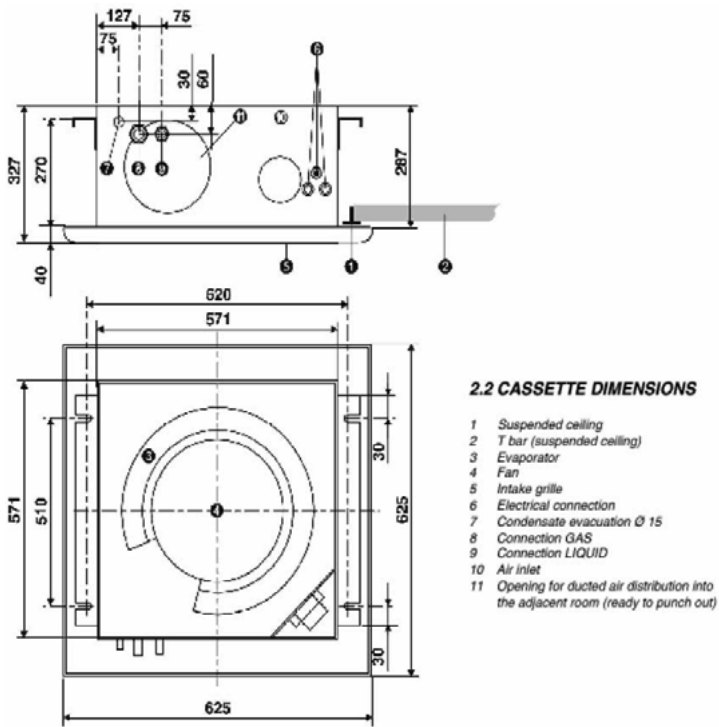

4.4 Indoor Unit: SX 9, 12, 18 DCI

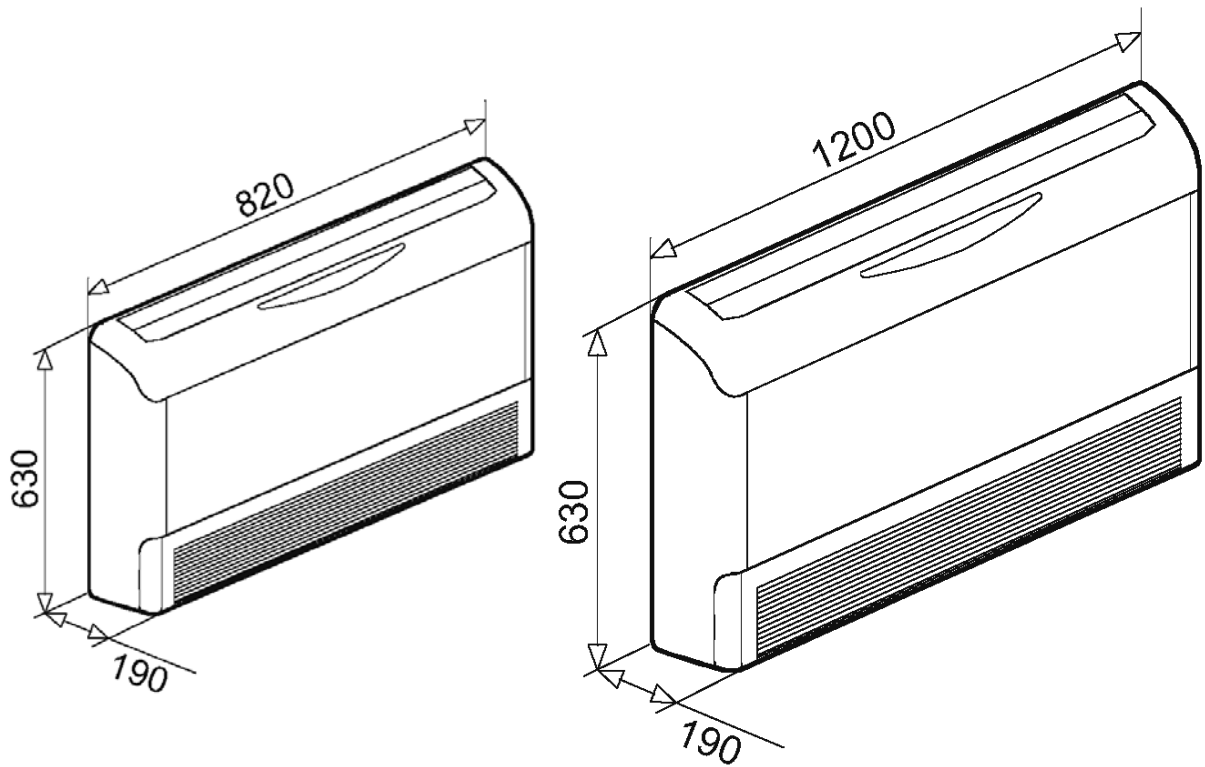

4.5 Indoor Unit: BS 12 DCI

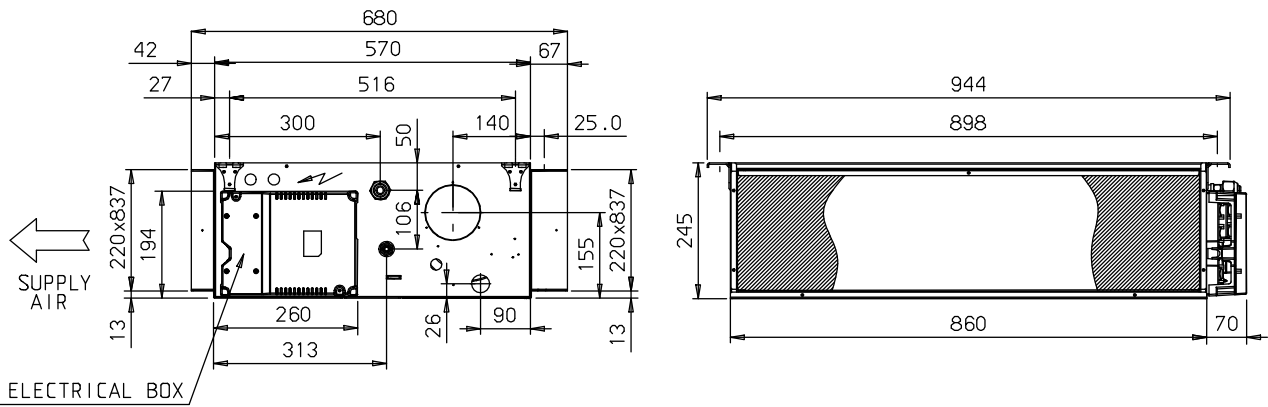

4.6 Outdoor Units: TRIO-72, QUATTRO-80 DCI

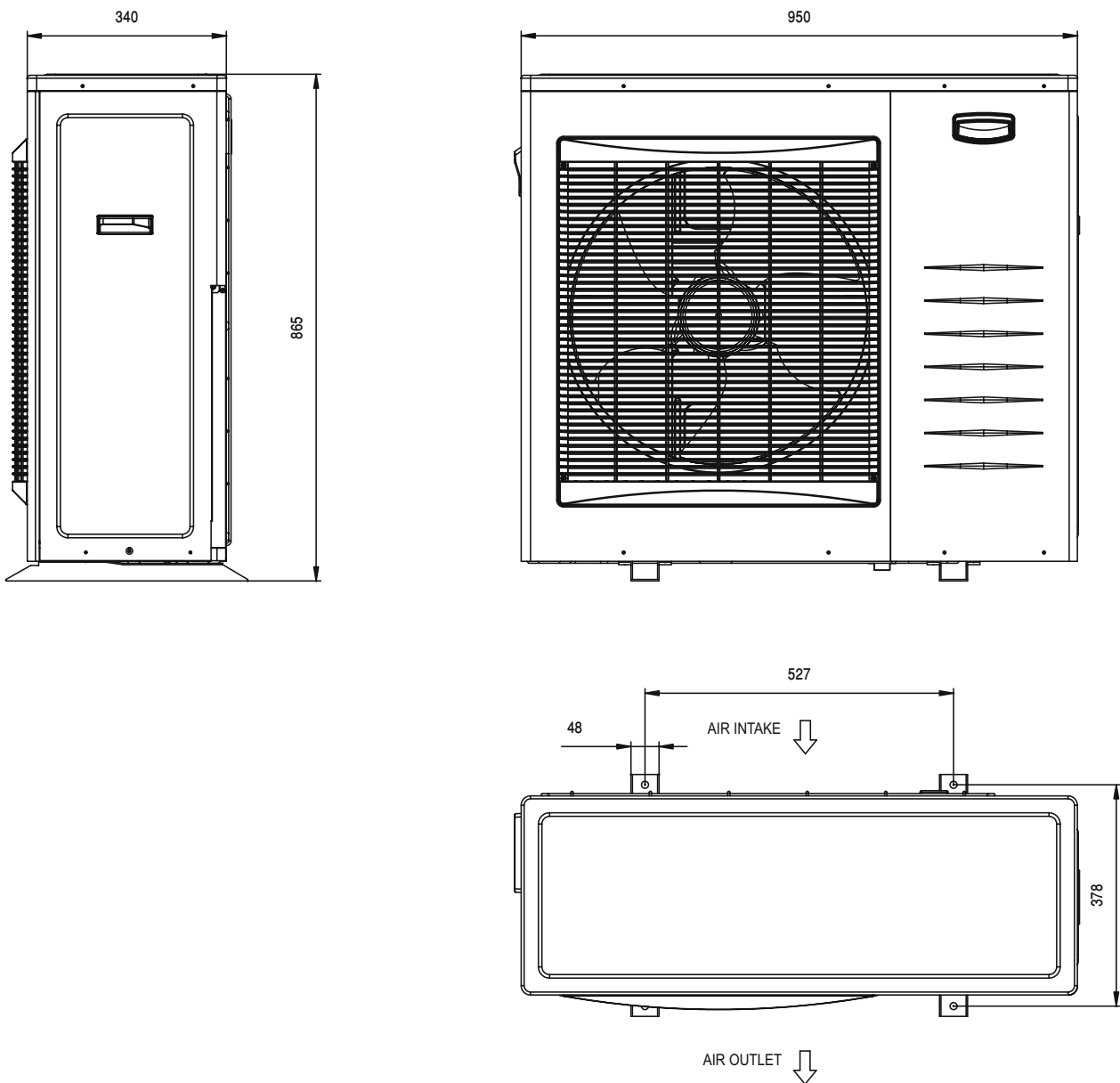

5. PERFORMANCE DATA

5.1 Outdoor Unit Trio-72 DCI Combinations (Based on FLO)

5.1.1 Cooling

Model	Cooling Capacity [KW]						Power Consumption [W]			COP Nom.	Energy Efficiency Class
	A	B	C	Nom.	Min.	Max.	Nom.	Min.	Max.		
9	-	-	2.50	2.50	1.30	3.70	685	500	1,025	3.65	A
12	-	-	3.50	3.50	1.30	4.40	968	500	1,223	3.62	A
18	-	-	5.00	5.00	1.49	5.93	1,393	566	1,656	3.59	A
9+9	-	2.54	2.54	5.08	1.86	6.56	1,498	683	1,856	3.39	A
9+12	-	2.57	3.42	5.99	1.86	7.73	1,783	683	2,541	3.36	A
9+18	-	2.44	4.88	7.32	1.86	9.00	2,203	659	3,046	3.32	A
12+18	-	3.46	3.46	6.92	1.86	9.00	2,075	683	2,246	3.33	A
12+12	-	2.93	4.39	7.32	1.86	9.00	2,203	659	3,055	3.32	A
9+9+9	2.40	2.40	2.40	7.20	2.69	8.98	2,240	949	3,049	3.21	A
9+9+12	2.20	2.20	2.93	7.33	2.69	9.00	2,281	949	3,157	3.21	A
9+9+18	1.83	1.83	3.66	7.32	2.69	9.00	2,278	962	3,097	3.21	A
9+12+12	1.99	2.66	2.66	7.31	2.69	9.00	2,275	949	3,097	3.21	A
9+12+18	1.69	2.25	3.37	7.31	2.69	9.00	2,275	962	3,061	3.21	A
12+12+12	2.44	2.44	2.44	7.32	2.69	9.00	2,278	990	3,085	3.21	A
12+12+18	2.09	2.09	3.13	7.30	2.69	9.00	2,272	962	3,086	3.21	A

 Nominal Indoor Units Combination

5.1 Outdoor Unit Trio-72 DCI Combinations (Based on FLO)

5.1.2 Cooling

Model	Sensible Cooling Capacity [KW]			
	A	B	C	Nom.
9	-	-	1.63	1.63
12	-	-	2.38	2.38
18	-	-	3.90	3.90
9+9	-	1.66	1.66	3.32
9+12	-	1.67	2.33	4.00
9+18	-	1.59	3.81	5.40
12+12	-	2.35	2.35	4.70
12+18	-	1.99	3.43	5.42
9+9+9	1.56	1.56	1.56	4.69
9+9+12	1.43	1.43	1.99	4.86
9+9+18	1.19	1.19	2.86	5.24
9+12+12	1.30	1.81	1.81	4.92
9+12+18	1.10	1.53	2.63	5.26
12+12+12	1.66	1.66	1.66	4.98
12+12+18	1.42	1.42	2.44	5.28

Nominal Indoor Units Combination

5.1.3 Heating

Model	Heating Capacity [KW]						Power Consumption [W]			COP Nom.	Energy Efficiency Class
	A	B	C	Nom.	Min.	Max.	Nom.	Min.	Max.		
9	-	-	3.40	3.40	0.95	4.00	685	500	897	4.96	A
12	-	-	4.30	4.30	0.95	5.20	1,003	485	1,320	4.29	A
18	-	-	6.20	6.20	1.11	7.50	1,673	549	2,131	3.71	A
9+9	-	3.60	3.60	7.20	1.43	9.10	1,883	649	2,636	3.82	A
9+12	-	3.26	4.34	7.60	1.43	9.50	2,009	649	2,711	3.78	A
9+18	-	3.00	6.00	9.00	1.43	10.10	2,451	622	2,737	3.67	A
12+12	-	4.00	4.00	8.00	1.43	9.80	2,135	649	2,711	3.75	A
12+18	-	3.60	5.40	9.00	1.43	10.50	2,451	622	2,871	3.67	A
9+9+9	3.00	3.00	3.00	9.00	2.06	10.99	2,370	804	3,013	3.80	A
9+9+12	2.70	2.70	3.60	9.00	2.06	11.00	2,370	804	2,966	3.80	A
9+9+18	2.25	2.25	4.50	9.00	2.06	11.00	2,370	773	2,826	3.80	A
12+12+12	2.45	3.27	3.27	8.99	2.06	11.00	2,367	804	2,938	3.80	A
9+12+18	2.07	2.76	4.14	8.98	2.14	11.00	2,365	773	2,752	3.80	A
12+12+12	3.00	3.00	3.00	9.00	2.06	11.00	2,370	804	2,845	3.80	A
12+12+18	2.57	2.57	3.85	8.99	2.14	11.00	2,367	773	2,696	3.80	A

 Nominal Indoor Units Combination

5.2 Outdoor Unit Quattro-80 DCI Combinations (Based on FLO)

5.2.1 Cooling

Model	Cooling Capacity [KW]							Power Consumption [W]			COP Nom.	Energy Efficiency Class
	A	B	C	D	Nom.	Min.	Max.	Nom.	Min.	Max.		
9	-	-	-	2.50	2.50	1.40	3.70	685	500	1,025	3.65	A
12	-	-	-	3.50	3.50	1.40	4.40	968	500	1,223	3.62	A
18	-	-	-	5.00	5.00	1.60	5.60	1,393	570	1,563	3.59	A
9+9	-	-	2.54	2.54	5.08	2.00	6.20	1,453	689	1,742	3.49	A
9+12	-	-	2.56	3.42	5.98	2.00	7.30	1,722	689	2,385	3.47	A
9+18	-	-	2.54	5.08	7.61	2.00	8.50	2,210	665	2,858	3.45	A
12+12	-	-	3.45	3.45	6.90	2.10	8.80	1,998	689	2,921	3.46	A
12+18	-	-	3.15	4.72	7.87	2.10	8.80	2,285	665	2,876	3.44	A
9+9+9	-	2.40	2.40	2.40	7.19	2.90	9.00	2,112	915	2,938	3.40	A
9+9+12	-	2.36	2.36	3.15	7.87	2.90	9.00	2,445	915	2,899	3.22	A
9+9+18	-	2.00	2.00	4.01	8.01	2.90	9.00	2,466	928	2,851	3.25	A
9+12+12	-	2.17	2.90	2.90	7.97	2.90	9.00	2,445	915	2,851	3.26	A
9+12+18	-	1.87	2.50	3.74	8.11	2.90	9.00	2,476	928	2,821	3.28	A
12+12+12	-	2.69	2.69	2.69	8.07	2.90	9.00	2,372	955	2,841	3.40	A
12+12+18	-	2.31	2.31	3.47	8.10	2.90	9.00	2,372	928	2,802	3.42	A
9+9+9+9	2.00	2.00	2.00	2.00	8.00	3.70	9.17	2,490	1,091	2,937	3.21	A
9+9+9+12	1.87	1.87	1.87	2.49	8.10	3.70	9.20	2,524	1,091	2,915	3.21	A
9+9+9+18	1.62	1.62	1.62	3.25	8.12	3.70	9.20	2,445	1,064	2,882	3.32	A
9+9+12+12	1.74	1.74	2.32	2.32	8.11	3.70	9.20	2,513	1,091	2,882	3.23	A
9+9+12+18	1.52	1.52	2.03	3.05	8.12	3.70	9.20	2,410	1,064	2,849	3.37	A
9+12+12+12	1.62	2.16	2.16	2.16	8.11	3.70	9.20	2,501	1,091	2,871	3.24	A
9+12+12+18	1.43	1.91	1.91	2.87	8.12	3.70	9.20	2,410	1,064	2,890	3.37	A
12+12+12+12	2.03	2.03	2.03	2.03	8.12	3.70	9.20	2,490	1,091	2,838	3.26	A

Nominal Indoor Units Combination

5.2 Outdoor Unit Quattro-80 DCI Combinations (Based on FLO)

5.2.2 Cooling

Model	Sensible Cooling Capacity [KW]				
	A	B	C	D	Nom.
9	-	-	-	1.63	1.63
12	-	-	-	2.38	2.38
18	-	-	-	3.90	3.90
9+9	-	-	1.65	1.65	3.31
9+12	-	-	1.67	2.32	3.99
9+18	-	-	1.65	3.96	5.61
12+12	-	-	2.35	2.35	4.69
12+18	-	-	2.14	3.68	5.82
9+9+9	-	1.56	1.56	1.56	4.69
9+9+12	-	1.54	1.54	2.14	5.22
12+12+18	-	1.31	1.31	3.12	5.74
9+12+12	-	1.42	1.97	1.97	5.36
9+12+18	-	1.22	1.70	2.92	5.84
12+12+12	-	1.83	1.83	1.83	5.49
12+12+18	-	1.57	1.57	2.71	5.86
9+9+9+9	1.30	1.30	1.30	1.30	5.22
9+9+9+12	1.22	1.22	1.22	1.70	5.35
9+9+9+18	1.06	1.06	1.06	2.53	5.71
9+9+12+12	1.13	1.13	1.58	1.58	5.42
9+9+12+18	0.99	0.99	1.38	2.38	5.74
9+12+12+12	1.06	1.47	1.47	1.47	5.47
9+12+12+18	0.93	1.30	1.30	2.24	5.77
12+12+12+12	1.38	1.38	1.38	1.38	5.52

 Nominal Indoor Units Combination

5.2.3 Heating

Model	Heating Capacity [KW]							Power Consumption [W]			COP Nom.	Energy Efficiency Class
	A	B	C	D	Nom.	Min.	Max.	Nom.	Min.	Max.		
9	-	-	-	3.40	3.40	0.95	4.00	685	400	859	4.96	A
12	-	-	-	4.30	4.30	0.95	5.20	946	388	1,207	4.54	A
18	-	-	-	6.20	6.20	1.11	7.50	1,497	455	1,875	4.14	A
9+9	-	-	3.64	3.64	7.28	1.43	8.63	1,707	539	2,172	4.26	A
9+12	-	-	3.29	4.39	7.68	1.43	9.01	1,838	539	2,235	4.18	A
9+18	-	-	3.03	6.06	9.10	1.43	9.58	2,261	516	2,255	4.02	A
12+12	-	-	4.04	4.04	8.09	1.43	9.29	1,920	539	2,235	4.21	A
12+18	-	-	3.80	5.70	9.50	1.43	9.96	2,317	516	2,366	4.10	A
9+9+9	-	3.03	3.03	3.03	9.10	2.06	11.00	2,151	671	2,621	4.23	A
9+9+12	-	2.85	2.85	3.80	9.50	2.06	11.00	2,231	671	2,891	4.26	A
9+9+18	-	2.38	2.38	4.75	9.50	2.06	11.00	2,072	646	2,883	4.59	A
9+12+12	-	2.59	3.45	3.45	9.48	2.06	11.00	2,171	671	2,874	4.37	A
9+12+18	-	2.19	2.92	4.38	9.48	2.14	11.00	2,012	646	2,731	4.71	A
12+12+12	-	3.16	3.16	3.16	9.49	2.06	11.00	2,151	671	2,857	4.41	A
12+12+18	-	2.71	2.71	4.06	9.48	2.14	11.00	1,993	646	2,671	4.76	A
9+9+9+9	2.38	2.38	2.38	2.38	9.50	2.69	10.97	2,380	657	2,935	3.99	A
9+9+9+12	2.19	2.19	2.19	2.91	9.47	2.69	11.00	2,355	657	2,900	4.02	A
9+9+9+18	1.90	1.90	1.90	3.80	9.50	2.77	11.00	2,294	646	2,779	4.14	A
9+9+12+12	2.03	2.03	2.71	2.71	9.49	2.69	11.00	2,306	657	2,857	4.12	A
9+9+12+18	1.78	1.78	2.37	3.56	9.49	2.77	11.00	2,195	646	2,762	4.32	A
9+12+12+12	1.90	2.53	2.53	2.53	9.48	2.69	11.00	2,269	657	2,822	4.18	A
9+12+12+18	1.67	2.23	2.23	3.35	9.48	2.77	11.00	2,195	646	2,903	4.32	A
12+12+12+12	2.38	2.38	2.38	2.38	9.50	2.69	11.00	2,380	646	2,796	3.99	A

Nominal Indoor Units Combination

5.3 FLO 9 DCI

5.3.1 Cooling Capacity Factors - Unit A,B,C or D

230[V] : Indoor Fan at High Speed.

OD COIL ENTERING AIR DB TEMPERATURE [°C]	DATA	ID COIL ENTERING AIR DB/WB TEMPERATURE [°C]				
		22/15	24/17	27/19	29/21	32/23
-10 - 20 (protection range)	TC	80 - 110 % of nominal				
	SC	80 - 105 % of nominal				
	PI	25 - 50 % of nominal				
25	TC	0.97	1.03	1.09	1.16	1.22
	SC	1.01	1.03	1.05	1.07	1.09
	PI	0.79	0.80	0.82	0.83	0.85
30	TC	0.92	0.98	1.05	1.11	1.17
	SC	0.98	1.00	1.03	1.05	1.07
	PI	0.88	0.89	0.91	0.92	0.94
35	TC	0.87	0.94	1.00	1.06	1.13
	SC	0.96	0.98	1.00	1.02	1.04
	PI	0.97	0.99	1.00	1.02	1.03
40	TC	0.83	0.89	0.95	1.02	1.08
	SC	0.93	0.95	0.97	1.00	1.02
	PI	1.06	1.08	1.09	1.11	1.12
46	TC	0.77	0.83	0.90	0.96	1.02
	SC	0.90	0.92	0.94	0.96	0.99
	PI	1.17	1.19	1.20	1.22	1.23

LEGEND

- TC – Total Cooling Capacity, kW
- SC – Sensible Capacity, kW
- PI – Power Input, kW
- WB – Wet Bulb Temp., (°C)
- DB – Dry Bulb Temp., (°C)
- ID – Indoor
- OD – Outdoor

5.3.2 Capacity Correction Factors

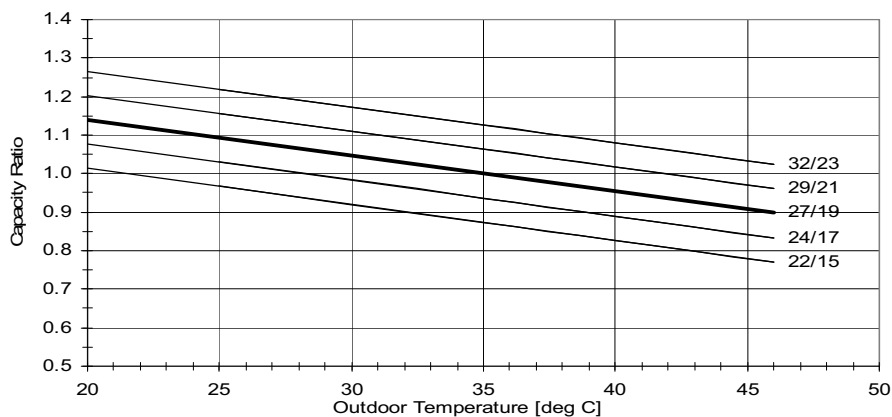

5.3.3 Heating Capacity Factors - Unit A,B,C or D

230[V] : Indoor Fan at High Speed.

OD COIL ENTERING AIR DB/WB TEMPERATURE [°C]		ID COIL ENTERING AIR DB TEMPERATURE [°C]		
		DATA	15	20
-15/-16	TC	0.64	0.59	0.55
	PI	0.60	0.66	0.72
-10/-12	TC	0.71	0.66	0.62
	PI	0.72	0.78	0.85
-7/-8	TC	0.76	0.72	0.67
	PI	0.82	0.88	0.94
-1/-2	TC	0.79	0.75	0.70
	PI	0.86	0.92	0.98
2/1	TC	0.81	0.76	0.72
	PI	0.89	0.95	1.01
7/6	TC	1.04	1.00	0.96
	PI	0.94	1.00	1.06
10/9	TC	1.10	1.06	1.01
	PI	1.00	1.06	1.12
15/12	TC	1.16	1.12	1.07
	PI	1.05	1.11	1.17
15-24 (Protection Range)	TC	85 - 105 % of nominal		
	PI	80 - 120 % of nominal		

LEGEND

- TC – Total Heating Capacity, kW
- PI – Power Input, kW
- WB – Wet Bulb Temp., (°C)
- DB – Dry Bulb Temp., (°C)
- ID – Indoor
- OU – Outdoor

5.3.4 Capacity Correction Factors

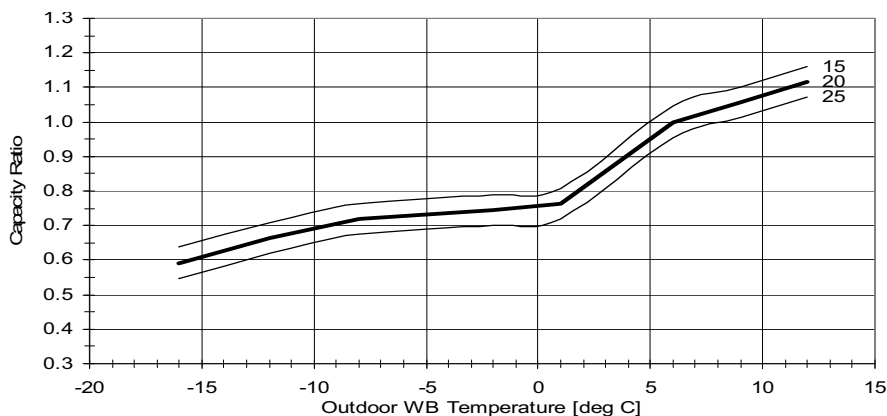

5.4 FLO 12 DCI

5.4.1 Cooling Capacity Factors - Unit A,B,C or D

230[V] : Indoor Fan at High Speed.

OD COIL ENTERING AIR DB TEMPERATURE [°C]		ID COIL ENTERING AIR DB/WB TEMPERATURE [°C]				
		22/15	24/17	27/19	29/21	32/23
-10 - 20 (protection range)	TC	80 - 110 % of nominal				
	SC	80 - 105 % of nominal				
	PI	25 - 50 % of nominal				
25	TC	0.97	1.03	1.09	1.16	1.22
	SC	1.01	1.03	1.05	1.07	1.09
	PI	0.79	0.80	0.82	0.83	0.85
30	TC	0.92	0.98	1.05	1.11	1.17
	SC	0.98	1.00	1.03	1.05	1.07
	PI	0.88	0.89	0.91	0.92	0.94
35	TC	0.87	0.94	1.00	1.06	1.13
	SC	0.96	0.98	1.00	1.02	1.04
	PI	0.97	0.99	1.00	1.02	1.03
40	TC	0.83	0.89	0.95	1.02	1.08
	SC	0.93	0.95	0.97	1.00	1.02
	PI	1.06	1.08	1.09	1.11	1.12
46	TC	0.77	0.83	0.90	0.96	1.02
	SC	0.90	0.92	0.94	0.96	0.99
	PI	1.17	1.19	1.20	1.22	1.23

LEGEND

- TC – Total Cooling Capacity, kW
- PI – Power Input, kW
- WB – Wet Bulb Temp., (°C)
- DB – Dry Bulb Temp., (°C)
- ID – Indoor
- OD – Outdoor

5.4.2 Capacity Correction Factors

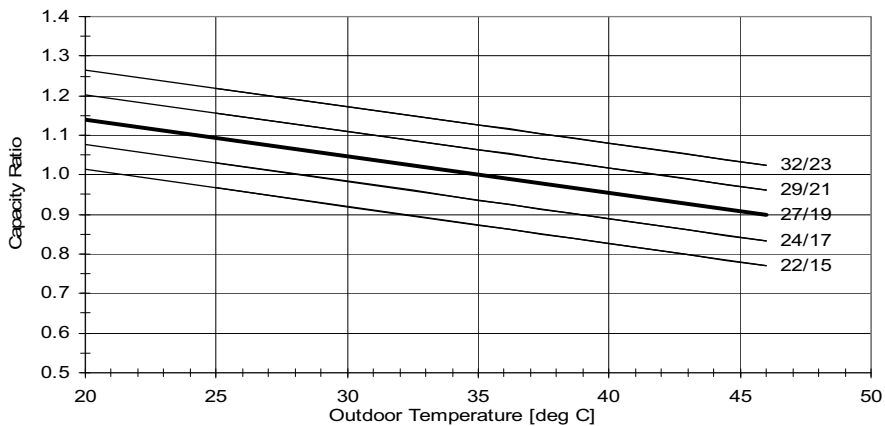

5.4.3 Heating Capacity Factors - Unit A,B,C or D

230[V] : Indoor Fan at High Speed.

OD COIL ENTERING AIR DB/WB TEMPERATURE [°C]	DATA	ID COIL ENTERING AIR DB TEMPERATURE [°C]		
		15	20	25
-15/-16	TC	0.64	0.59	0.55
	PI	0.60	0.66	0.72
-10/-12	TC	0.71	0.66	0.62
	PI	0.72	0.78	0.85
-7/-8	TC	0.76	0.72	0.67
	PI	0.82	0.88	0.94
-1/-2	TC	0.79	0.75	0.70
	PI	0.86	0.92	0.98
2/1	TC	0.81	0.76	0.72
	PI	0.89	0.95	1.01
7/6	TC	1.04	1.00	0.96
	PI	0.94	1.00	1.06
10/9	TC	1.10	1.06	1.01
	PI	1.00	1.06	1.12
15/12	TC	1.16	1.12	1.07
	PI	1.05	1.11	1.17
15-24 (Protection Range)	TC	85 - 105 % of nominal		
	PI	80 - 120 % of nominal		

LEGEND

- TC – Total Heating Capacity, kW
- PI – Power Input, kW
- WB – Wet Bulb Temp., (°C)
- DB – Dry Bulb Temp., (°C)
- ID – Indoor
- OU – Outdoor

5.4.4 Capacity Correction Factors

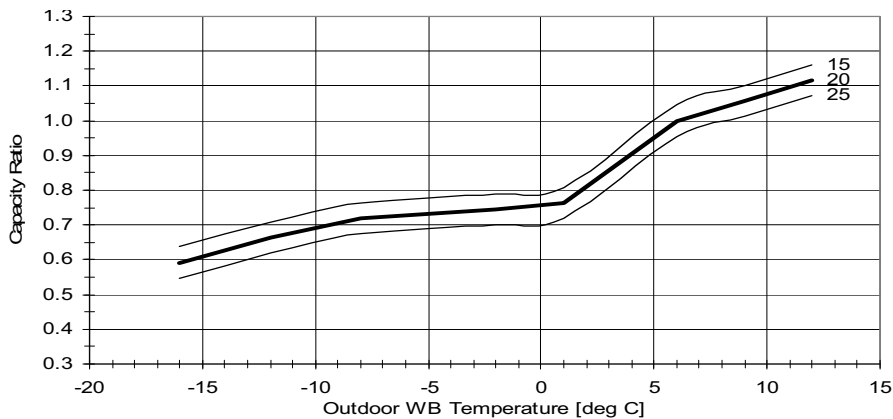

5.5 FLO 18 DCI

5.5.1 Cooling Capacity Factors - Unit D

230[V] : Indoor Fan at High Speed.

		ID COIL ENTERING AIR DB/WB TEMPERATURE [°C]				
OD COIL ENTERING AIR DB TEMPERATURE [°C]	DATA	22/15	24/17	27/19	29/21	32/23
-10 - 20 (protection range)	TC	80 - 110 % of nominal				
	SC	80 - 105 % of nominal				
	PI	25 - 50 % of nominal				
25	TC	0.99	1.04	1.10	1.16	1.22
	SC	1.05	1.07	1.08	1.10	1.11
	PI	0.76	0.77	0.79	0.81	0.82
30	TC	0.93	0.99	1.05	1.11	1.17
	SC	1.01	1.03	1.04	1.06	1.07
	PI	0.86	0.88	0.90	0.91	0.93
35	TC	0.88	0.94	1.00	1.06	1.12
	SC	0.97	0.98	1.00	1.02	1.03
	PI	0.97	0.98	1.00	1.02	1.03
40	TC	0.83	0.89	0.95	1.01	1.07
	SC	0.93	0.94	0.96	0.97	0.99
	PI	1.07	1.09	1.11	1.12	1.14
46	TC	0.77	0.83	0.89	0.95	1.00
	SC	0.88	0.89	0.91	0.93	0.94
	PI	1.20	1.21	1.23	1.25	1.27

LEGEND

- TC – Total Cooling Capacity, kW
- PI – Power Input, kW
- WB – Wet Bulb Temp., (°C)
- DB – Dry Bulb Temp., (°C)
- ID – Indoor
- OD – Outdoor

5.5.2 Capacity Correction Facto

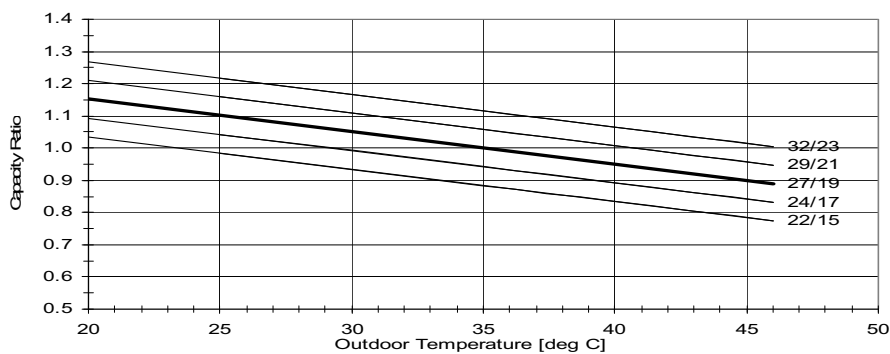

5.5.3 Heating Capacity Factors - Unit D

230[V] : Indoor Fan at High Speed.

OD COIL ENTERING AIR DB/WB TEMPERATURE [°C]		ID COIL ENTERING AIR DB TEMPERATURE [°C]		
		DATA	15	20
-15/-16	TC	0.46	0.39	0.32
	PI	0.70	0.75	0.80
-10/-12	TC	0.60	0.54	0.47
	PI	0.79	0.84	0.89
-7/-8	TC	0.71	0.64	0.58
	PI	0.86	0.91	0.96
-1/-2	TC	0.76	0.70	0.63
	PI	0.89	0.94	0.99
2/1	TC	0.80	0.74	0.67
	PI	0.92	0.97	1.02
7/6	TC	1.07	1.00	0.93
	PI	0.95	1.00	1.05
10/9	TC	1.12	1.06	0.99
	PI	0.97	1.02	1.07
15/12	TC	1.18	1.11	1.04
	PI	0.99	1.04	1.09
15-24 (Protection Range)	TC	85 - 105 % of nominal		
	PI	80 - 120 % of nominal		

LEGEND

- TC – Total Cooling Capacity, kW
- SC – Sensible Capacity, kW
- PI – Power Input, kW
- WB – Wet Bulb Temp., (°C)
- DB – Dry Bulb Temp., (°C)
- ID – Indoor
- OD – Outdoor

5.5.4 Capacity Correction Factors

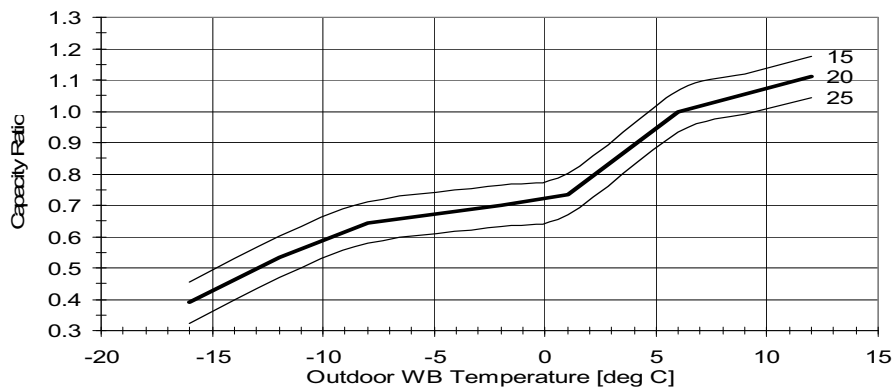

5.6 K 9 DCI

5.6.1 Cooling Capacity Factors - Unit A,B,C or D

230[V] : Indoor Fan at High Speed.

OD COIL ENTERING AIR DB TEMPERATURE [°C]	DATA	ID COIL ENTERING AIR DB/WB TEMPERATURE [°C]				
		22/15	24/17	27/19	29/21	32/23
-10 - 20 (protection range)	TC	80 - 110 % of nominal				
	SC	80 - 105 % of nominal				
	PI	25 - 50 % of nominal				
25	TC	0.97	1.03	1.09	1.16	1.22
	SC	1.01	1.03	1.05	1.07	1.09
	PI	0.79	0.80	0.82	0.83	0.85
30	TC	0.92	0.98	1.05	1.11	1.17
	SC	0.98	1.00	1.03	1.05	1.07
	PI	0.88	0.89	0.91	0.92	0.94
35	TC	0.87	0.94	1.00	1.06	1.13
	SC	0.96	0.98	1.00	1.02	1.04
	PI	0.97	0.99	1.00	1.02	1.03
40	TC	0.83	0.89	0.95	1.02	1.08
	SC	0.93	0.95	0.97	1.00	1.02
	PI	1.06	1.08	1.09	1.11	1.12
46	TC	0.77	0.83	0.90	0.96	1.02
	SC	0.90	0.92	0.94	0.96	0.99
	PI	1.17	1.19	1.20	1.22	1.23

LEGEND

- TC - Total Cooling Capacity, kW
- PI - Power Input, kW
- WB - Wet Bulb Temp., (°C)
- DB - Dry Bulb Temp., (°C)
- ID - Indoor
- OD - Outdoor

5.6.2 Capacity Correction Factors

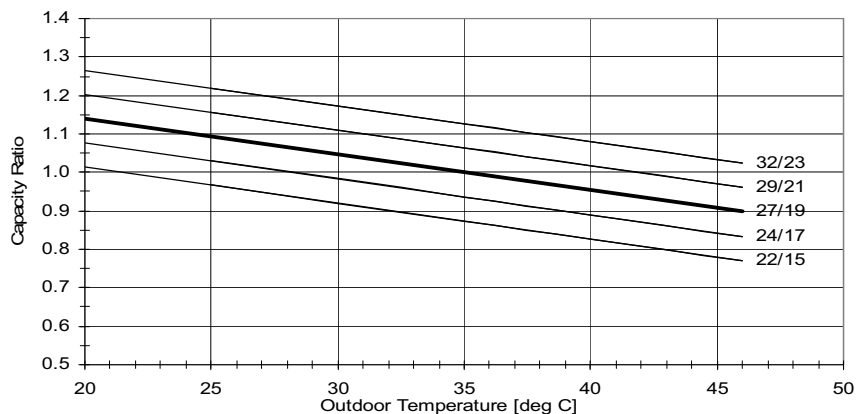

5.6.3 Heating Capacity Factors - Unit A,B,C or D
230[V] : Indoor Fan at High Speed.

OD COIL ENTERING AIR DB/WB TEMPERATURE [°C]		ID COIL ENTERING AIR DB TEMPERATURE [°C]		
		DATA	15	20
-15/-16	TC	0.64	0.59	0.55
	PI	0.60	0.66	0.72
-10/-12	TC	0.71	0.66	0.62
	PI	0.72	0.78	0.85
-7/-8	TC	0.76	0.72	0.67
	PI	0.82	0.88	0.94
-1/-2	TC	0.79	0.75	0.70
	PI	0.86	0.92	0.98
2/1	TC	0.81	0.76	0.72
	PI	0.89	0.95	1.01
7/6	TC	1.04	1.00	0.96
	PI	0.94	1.00	1.06
10/9	TC	1.10	1.06	1.01
	PI	1.00	1.06	1.12
15/12	TC	1.16	1.12	1.07
	PI	1.05	1.11	1.17
15-24 (Protection Range)	TC	85 - 105 % of nominal		
	PI	80 - 120 % of nominal		

LEGEND

- TC – Total Heating Capacity, kW
- PI – Power Input, kW
- WB – Wet Bulb Temp., (°C)
- DB – Dry Bulb Temp., (°C)
- ID – Indoor
- OU – Outdoor

5.6.4 Capacity Correction Factors

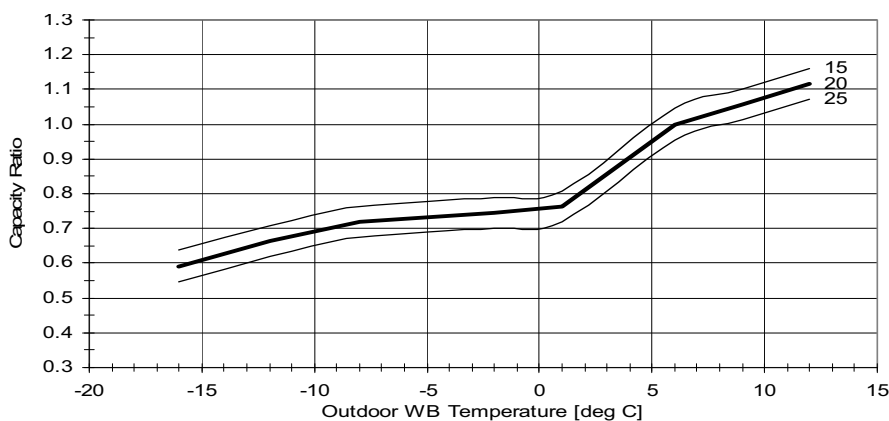

5.7 K 12 DCI

5.7.1 Cooling Capacity Factors - Run Mode (Unit A,B,C or D)

230[V] : Indoor Fan at High Speed.

OD COIL ENTERING AIR DB TEMPERATURE [°C]	DATA	ID COIL ENTERING AIR DB/WB TEMPERATURE [°C]				
		22/15	24/17	27/19	29/21	32/23
-10 - 20 (protection range)	TC	80 - 110 % of nominal				
	SC	80 - 105 % of nominal				
	PI	25 - 50 % of nominal				
25	TC	0.97	1.03	1.09	1.16	1.22
	SC	1.01	1.03	1.05	1.07	1.09
	PI	0.79	0.80	0.82	0.83	0.85
30	TC	0.92	0.98	1.05	1.11	1.17
	SC	0.98	1.00	1.03	1.05	1.07
	PI	0.88	0.89	0.91	0.92	0.94
35	TC	0.87	0.94	1.00	1.06	1.13
	SC	0.96	0.98	1.00	1.02	1.04
	PI	0.97	0.99	1.00	1.02	1.03
40	TC	0.83	0.89	0.95	1.02	1.08
	SC	0.93	0.95	0.97	1.00	1.02
	PI	1.06	1.08	1.09	1.11	1.12
46	TC	0.77	0.83	0.90	0.96	1.02
	SC	0.90	0.92	0.94	0.96	0.99
	PI	1.17	1.19	1.20	1.22	1.23

LEGEND

- TC - Total Cooling Capacity, kW
- PI - Power Input, kW
- WB - Wet Bulb Temp., (°C)
- DB - Dry Bulb Temp., (°C)
- ID - Indoor
- OD - Outdoor

5.7.2 Capacity Correction Factors

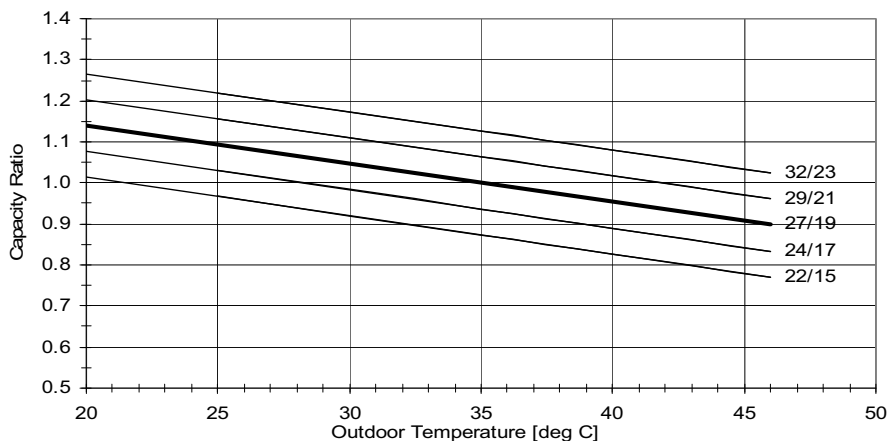

5.7.3 Heating Capacity Factors - Unit A,B,C or D
230[V] : Indoor Fan at High Speed.

OD COIL ENTERING AIR DB/ WB TEMPERATURE [°C]		ID COIL ENTERING AIR DB TEMPERATURE [°C]		
		DATA	15	20
-15/-16	TC	0.64	0.59	0.55
	PI	0.60	0.66	0.72
-10/-12	TC	0.71	0.66	0.62
	PI	0.72	0.78	0.85
-7/-8	TC	0.76	0.72	0.67
	PI	0.82	0.88	0.94
-1/-2	TC	0.79	0.75	0.70
	PI	0.86	0.92	0.98
2/1	TC	0.81	0.76	0.72
	PI	0.89	0.95	1.01
7/6	TC	1.04	1.00	0.96
	PI	0.94	1.00	1.06
10/9	TC	1.10	1.06	1.01
	PI	1.00	1.06	1.12
15/12	TC	1.16	1.12	1.07
	PI	1.05	1.11	1.17
15-24 (Protection Range)	TC	85 - 105 % of nominal		
	PI	80 - 120 % of nominal		

LEGEND

- TC – Total Heating Capacity, kW
- PI – Power Input, kW
- WB – Wet Bulb Temp., (°C)
- DB – Dry Bulb Temp., (°C)
- ID – Indoor
- OU – Outdoor

5.7.4 Capacity Correction Factors

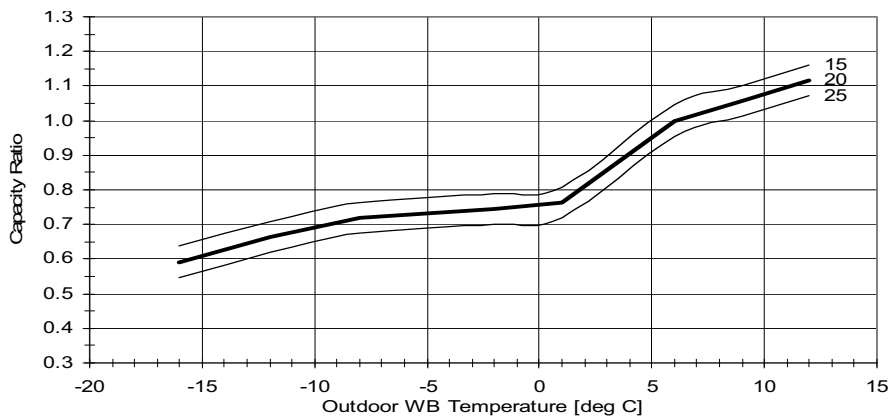

5.8 K 18 DCI

5.8.1 Cooling Capacity Factor - Unit D

230[V] : Indoor Fan at High Speed.

OD COIL ENTERING AIR DB TEMPERATURE [°C]	DATA	ID COIL ENTERING AIR DB/WB TEMPERATURE [°C]				
		22/15	24/17	27/19	29/21	32/23
-10 - 20 (protection range)	TC	80 - 110 % of nominal				
	SC	80 - 105 % of nominal				
	PI	25 - 50 % of nominal				
25	TC	0.99	1.04	1.10	1.16	1.22
	SC	1.05	1.07	1.08	1.10	1.11
	PI	0.76	0.77	0.79	0.81	0.82
30	TC	0.93	0.99	1.05	1.11	1.17
	SC	1.01	1.03	1.04	1.06	1.07
	PI	0.86	0.88	0.90	0.91	0.93
35	TC	0.88	0.94	1.00	1.06	1.12
	SC	0.97	0.98	1.00	1.02	1.03
	PI	0.97	0.98	1.00	1.02	1.03
40	TC	0.83	0.89	0.95	1.01	1.07
	SC	0.93	0.94	0.96	0.97	0.99
	PI	1.07	1.09	1.11	1.12	1.14
46	TC	0.77	0.83	0.89	0.95	1.00
	SC	0.88	0.89	0.91	0.93	0.94
	PI	1.20	1.21	1.23	1.25	1.27

LEGEND

- TC - Total Cooling Capacity, kW
- PI - Power Input, kW
- WB - Wet Bulb Temp., (°C)
- DB - Dry Bulb Temp., (°C)
- ID - Indoor
- OD - Outdoor

5.8.2 Capacity Correction Factors

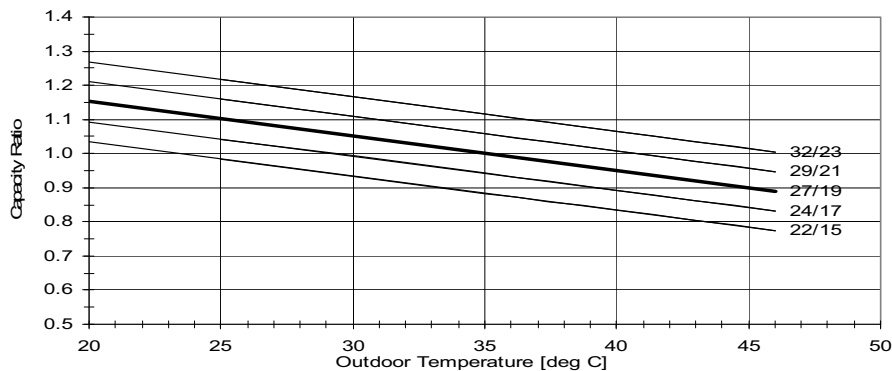

5.8.3 Heating Capacity Factor - Unit D
230[V] : Indoor Fan at High Speed.

OD COIL ENTERING AIR DB/WB TEMPERATURE [°C]		ID COIL ENTERING AIR DB TEMPERATURE [°C]		
		15	20	25
-15/-16	TC	0.46	0.39	0.32
	PI	0.70	0.75	0.80
-10/-12	TC	0.60	0.54	0.47
	PI	0.79	0.84	0.89
-7/-8	TC	0.71	0.64	0.58
	PI	0.86	0.91	0.96
-1/-2	TC	0.76	0.70	0.63
	PI	0.89	0.94	0.99
2/1	TC	0.80	0.74	0.67
	PI	0.92	0.97	1.02
7/6	TC	1.07	1.00	0.93
	PI	0.95	1.00	1.05
10/9	TC	1.12	1.06	0.99
	PI	0.97	1.02	1.07
15/12	TC	1.18	1.11	1.04
	PI	0.99	1.04	1.09
15-24 (Protection Range)	TC	85 - 105 % of nominal		
	PI	80 - 120 % of nominal		

LEGEND

- TC – Total Heating Capacity, kW
- PI – Power Input, kW
- WB – Wet Bulb Temp., (°C)
- DB – Dry Bulb Temp., (°C)
- ID – Indoor
- OU – Outdoor

5.8.4 Capacity Correction Factors

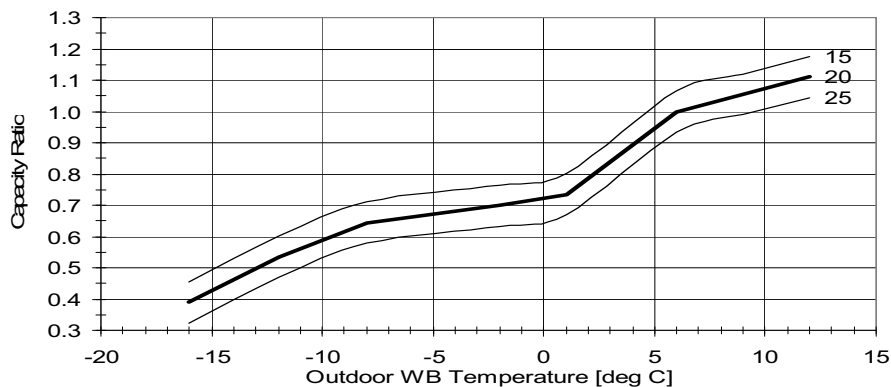

5.9 SX 9 DCI

5.9.1 Cooling Capacity Factors - Unit A,B,C or D

230[V] : Indoor Fan at High Speed

OD COIL ENTERING AIR DB TEMPERATURE [°C]		DATA	ID COIL ENTERING AIR DB/WB TEMPERATURE [°C]				
			22/15	24/17	27/19	29/21	32/23
-10 - 20 (protection range)	TC	80 - 110 % of nominal					
	SC	80 - 105 % of nominal					
	PI	25 - 50 % of nominal					
25	TC	0.97	1.03	1.09	1.16	1.22	
	SC	1.01	1.03	1.05	1.07	1.09	
	PI	0.79	0.80	0.82	0.83	0.85	
30	TC	0.92	0.98	1.05	1.11	1.17	
	SC	0.98	1.00	1.03	1.05	1.07	
	PI	0.88	0.89	0.91	0.92	0.94	
35	TC	0.87	0.94	1.00	1.06	1.13	
	SC	0.96	0.98	1.00	1.02	1.04	
	PI	0.97	0.99	1.00	1.02	1.03	
40	TC	0.83	0.89	0.95	1.02	1.08	
	SC	0.93	0.95	0.97	1.00	1.02	
	PI	1.06	1.08	1.09	1.11	1.12	
46	TC	0.77	0.83	0.90	0.96	1.02	
	SC	0.90	0.92	0.94	0.96	0.99	
	PI	1.17	1.19	1.20	1.22	1.23	

LEGEND

- TC – Total Cooling Capacity, kW
- PI – Power Input, kW
- WB – Wet Bulb Temp., (°C)
- DB – Dry Bulb Temp., (°C)
- ID – Indoor
- OD – Outdoor

5.9.2 Capacity Correction Factors

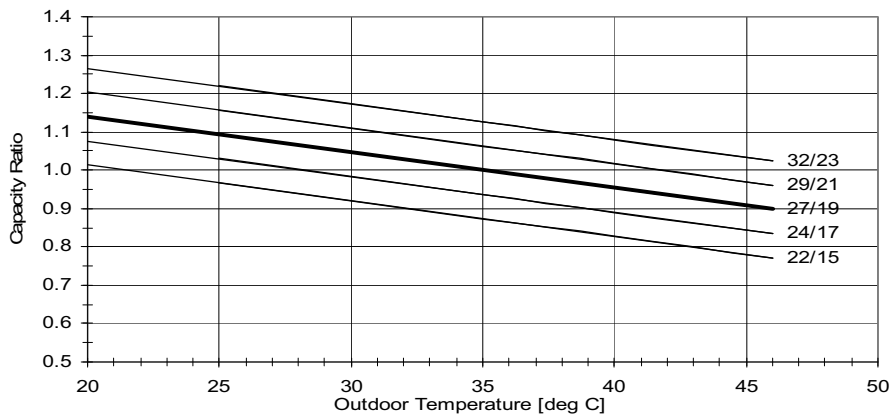

5.9.3 Heating Capacity Factors - Unit A,B,C or D
230[V] : Indoor Fan at High Speed.

OD COIL ENTERING AIR DB/ WB TEMPERATURE [°C]	DATA	ID COIL ENTERING AIR DB TEMPERATURE [°C]		
		15	20	25
-15/-16	TC	0.64	0.59	0.55
	PI	0.60	0.66	0.72
-10/-12	TC	0.71	0.66	0.62
	PI	0.72	0.78	0.85
-7/-8	TC	0.76	0.72	0.67
	PI	0.82	0.88	0.94
-1/-2	TC	0.79	0.75	0.70
	PI	0.86	0.92	0.98
2/1	TC	0.81	0.76	0.72
	PI	0.89	0.95	1.01
7/6	TC	1.04	1.00	0.96
	PI	0.94	1.00	1.06
10/9	TC	1.10	1.06	1.01
	PI	1.00	1.06	1.12
15/12	TC	1.16	1.12	1.07
	PI	1.05	1.11	1.17
15-24 (Protection Range)	TC	85 - 105 % of nominal		
	PI	80 - 120 % of nominal		

LEGEND

- TC – Total Heating Capacity, kW
- PI – Power Input, kW
- WB – Wet Bulb Temp., (°C)
- DB – Dry Bulb Temp., (°C)
- ID – Indoor
- OU – Outdoor

5.9.4 Capacity Correction Factors

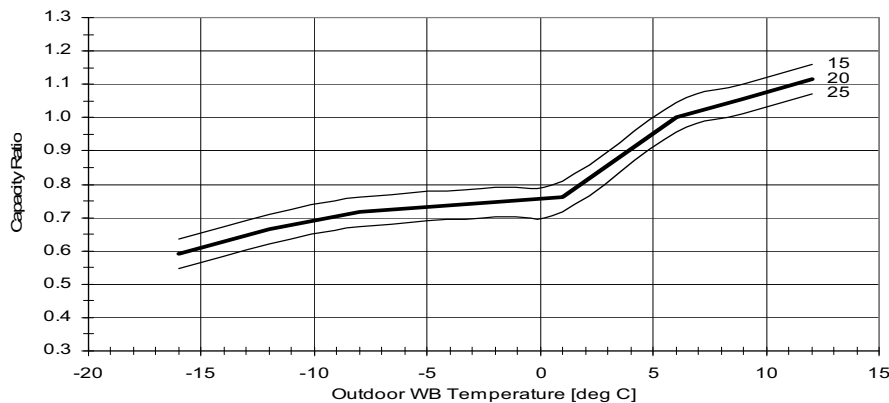

5.10 SX 12 DCI

5.10.1 Cooling Capacity Factors - Run Mode (Unit A,B,C or D)

230[V] : Indoor Fan at High Speed.

OD COIL ENTERING AIR DB TEMPERATURE [°C]	DATA	ID COIL ENTERING AIR DB/WB TEMPERATURE [°C]				
		22/15	24/17	27/19	29/21	32/23
-10 - 20 (protection range)	TC	80 - 110 % of nominal				
	SC	80 - 105 % of nominal				
	PI	25 - 50 % of nominal				
25	TC	0.97	1.03	1.09	1.16	1.22
	SC	1.01	1.03	1.05	1.07	1.09
	PI	0.79	0.80	0.82	0.83	0.85
30	TC	0.92	0.98	1.05	1.11	1.17
	SC	0.98	1.00	1.03	1.05	1.07
	PI	0.88	0.89	0.91	0.92	0.94
35	TC	0.87	0.94	1.00	1.06	1.13
	SC	0.96	0.98	1.00	1.02	1.04
	PI	0.97	0.99	1.00	1.02	1.03
40	TC	0.83	0.89	0.95	1.02	1.08
	SC	0.93	0.95	0.97	1.00	1.02
	PI	1.06	1.08	1.09	1.11	1.12
46	TC	0.77	0.83	0.90	0.96	1.02
	SC	0.90	0.92	0.94	0.96	0.99
	PI	1.17	1.19	1.20	1.22	1.23

LEGEND

- TC – Total Cooling Capacity, kW
- PI – Power Input, kW
- WB – Wet Bulb Temp., (°C)
- DB – Dry Bulb Temp., (°C)
- ID – Indoor
- OD – Outdoor

5.10.2 Capacity Correction Factors

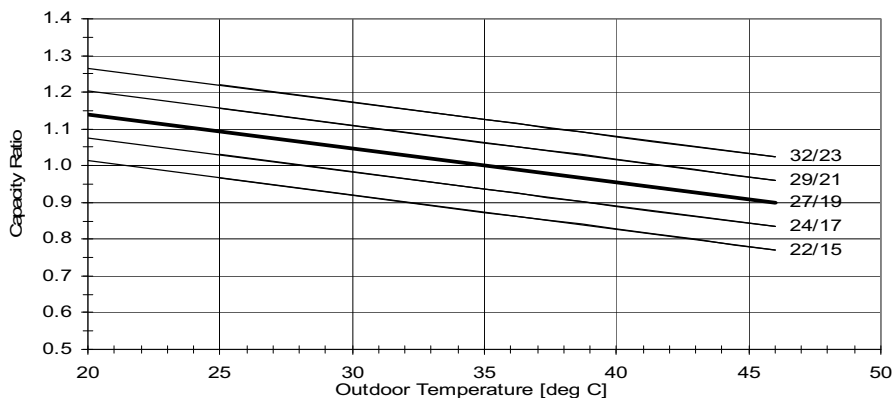

5.10.3 Heating Capacity Factors - Unit A,B,C or D
230[V] : Indoor Fan at High Speed.

OD COIL ENTERING AIR DB/ WB TEMPERATURE [°C]		ID COIL ENTERING AIR DB TEMPERATURE [°C]		
		15	20	25
-15/-16	TC	0.64	0.59	0.55
	PI	0.60	0.66	0.72
-10/-12	TC	0.71	0.66	0.62
	PI	0.72	0.78	0.85
-7/-8	TC	0.76	0.72	0.67
	PI	0.82	0.88	0.94
-1/-2	TC	0.79	0.75	0.70
	PI	0.86	0.92	0.98
2/1	TC	0.81	0.76	0.72
	PI	0.89	0.95	1.01
7/6	TC	1.04	1.00	0.96
	PI	0.94	1.00	1.06
10/9	TC	1.10	1.06	1.01
	PI	1.00	1.06	1.12
15/12	TC	1.16	1.12	1.07
	PI	1.05	1.11	1.17
15-24 (Protection Range)	TC	85 - 105 % of nominal		
	PI	80 - 120 % of nominal		

LEGEND

- TC – Total Heating Capacity, kW
- PI – Power Input, kW
- WB – Wet Bulb Temp., (°C)
- DB – Dry Bulb Temp., (°C)
- ID – Indoor
- OU – Outdoor

5.10.4 Capacity Correction Factors

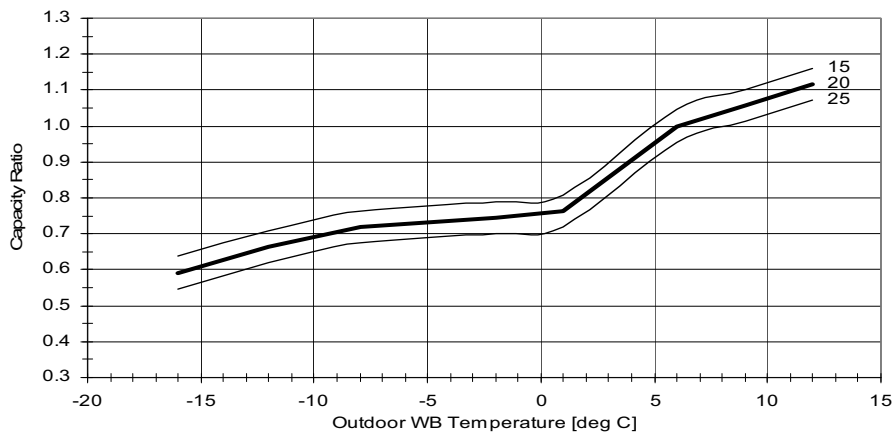

5.11 SX 18 DCI

5.11.1 Cooling Capacity Factor - Unit D

230[V] : Indoor Fan at High Speed.

OD COIL ENTERING AIR DB TEMPERATURE [°C]		ID COIL ENTERING AIR DB/WB TEMPERATURE [°C]				
		22/15	24/17	27/19	29/21	32/23
-10 - 20 (protection range)	TC	80 - 110 % of nominal				
	SC	80 - 105 % of nominal				
	PI	25 - 50 % of nominal				
25	TC	0.99	1.04	1.10	1.16	1.22
	SC	1.05	1.07	1.08	1.10	1.11
	PI	0.76	0.77	0.79	0.81	0.82
30	TC	0.93	0.99	1.05	1.11	1.17
	SC	1.01	1.03	1.04	1.06	1.07
	PI	0.86	0.88	0.90	0.91	0.93
35	TC	0.88	0.94	1.00	1.06	1.12
	SC	0.97	0.98	1.00	1.02	1.03
	PI	0.97	0.98	1.00	1.02	1.03
40	TC	0.83	0.89	0.95	1.01	1.07
	SC	0.93	0.94	0.96	0.97	0.99
	PI	1.07	1.09	1.11	1.12	1.14
46	TC	0.77	0.83	0.89	0.95	1.00
	SC	0.88	0.89	0.91	0.93	0.94
	PI	1.20	1.21	1.23	1.25	1.27

LEGEND

- TC – Total Cooling Capacity, kW
- PI – Power Input, kW
- WB – Wet Bulb Temp., (°C)
- DB – Dry Bulb Temp., (°C)
- ID – Indoor
- OD – Outdoor

5.11.2 Capacity Correction Factors

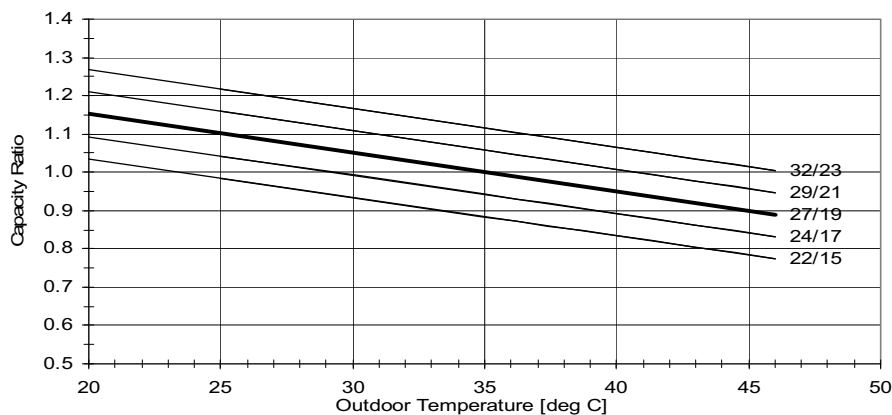

5.11.3 Heating Capacity Factor - Unit D
230[V] : Indoor Fan at High Speed.

OD COIL ENTERING AIR DB/ WB TEMPERATURE [°C]	DATA	ID COIL ENTERING AIR DB TEMPERATURE [°C]		
		15	20	25
-15/-16	TC	0.46	0.39	0.32
	PI	0.70	0.75	0.80
-10/-12	TC	0.60	0.54	0.47
	PI	0.79	0.84	0.89
-7/-8	TC	0.71	0.64	0.58
	PI	0.86	0.91	0.96
-1/-2	TC	0.76	0.70	0.63
	PI	0.89	0.94	0.99
2/1	TC	0.80	0.74	0.67
	PI	0.92	0.97	1.02
7/6	TC	1.07	1.00	0.93
	PI	0.95	1.00	1.05
10/9	TC	1.12	1.06	0.99
	PI	0.97	1.02	1.07
15/12	TC	1.18	1.11	1.04
	PI	0.99	1.04	1.09
15-24 (Protection Range)	TC	85 - 105 % of nominal		
	PI	80 - 120 % of nominal		

LEGEND

- TC – Total Heating Capacity, kW
- PI – Power Input, kW
- WB – Wet Bulb Temp., (°C)
- DB – Dry Bulb Temp., (°C)
- ID – Indoor
- OU – Outdoor

5.11.4 Capacity Correction Factors

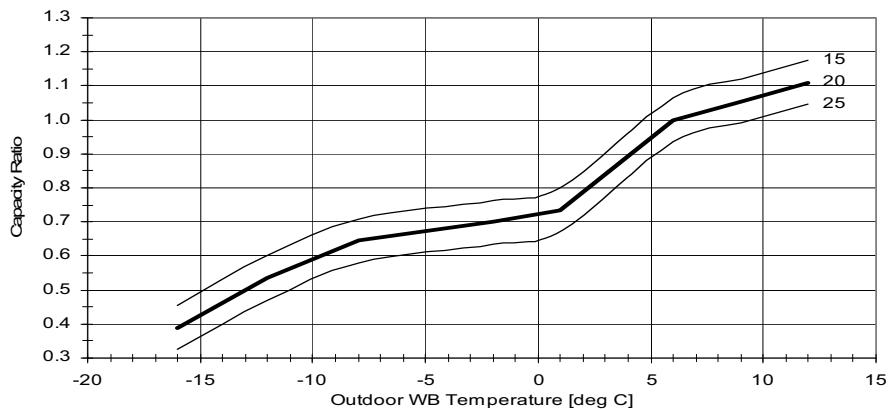

5.12 BS 12 DCI

5.12.1 Cooling Capacity Factors - Run Mode (Unit A,B,C or D)

230[V] : Indoor Fan at High Speed.

OD COIL ENTERING AIR DB TEMPERATURE [°C]	DATA	ID COIL ENTERING AIR DB/WB TEMPERATURE [°C]				
		22/15	24/17	27/19	29/21	32/23
-10 - 20 (protection range)	TC	80 - 110 % of nominal				
	SC	80 - 105 % of nominal				
	PI	25 - 50 % of nominal				
25	TC	0.97	1.03	1.09	1.16	1.22
	SC	1.01	1.03	1.05	1.07	1.09
	PI	0.79	0.80	0.82	0.83	0.85
30	TC	0.92	0.98	1.05	1.11	1.17
	SC	0.98	1.00	1.03	1.05	1.07
	PI	0.88	0.89	0.91	0.92	0.94
35	TC	0.87	0.94	1.00	1.06	1.13
	SC	0.96	0.98	1.00	1.02	1.04
	PI	0.97	0.99	1.00	1.02	1.03
40	TC	0.83	0.89	0.95	1.02	1.08
	SC	0.93	0.95	0.97	1.00	1.02
	PI	1.06	1.08	1.09	1.11	1.12
46	TC	0.77	0.83	0.90	0.96	1.02
	SC	0.90	0.92	0.94	0.96	0.99
	PI	1.17	1.19	1.20	1.22	1.23

LEGEND

- TC – Total Cooling Capacity, kW
- PI – Power Input, kW
- WB – Wet Bulb Temp., (°C)
- DB – Dry Bulb Temp., (°C)
- ID – Indoor
- OD – Outdoor

5.12.2 Capacity Correction Factors

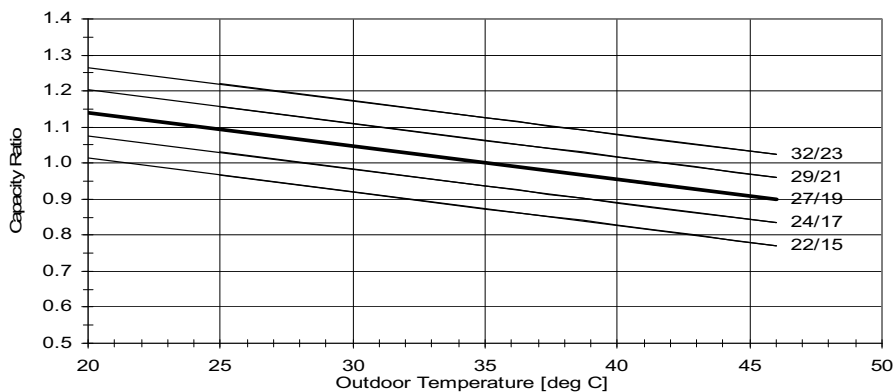

5.12.3 Heating Capacity Factors - Unit A,B,C or D
230[V] : Indoor Fan at High Speed.

OD COIL ENTERING AIR DB/WB TEMPERATURE [°C]	DATA	ID COIL ENTERING AIR DB TEMPERATURE [°C]		
		15	20	25
-15/-16	TC	0.64	0.59	0.55
	PI	0.60	0.66	0.72
-10/-12	TC	0.71	0.66	0.62
	PI	0.72	0.78	0.85
-7/-8	TC	0.76	0.72	0.67
	PI	0.82	0.88	0.94
-1/-2	TC	0.79	0.75	0.70
	PI	0.86	0.92	0.98
2/1	TC	0.81	0.76	0.72
	PI	0.89	0.95	1.01
7/6	TC	1.04	1.00	0.96
	PI	0.94	1.00	1.06
10/9	TC	1.10	1.06	1.01
	PI	1.00	1.06	1.12
15/12	TC	1.16	1.12	1.07
	PI	1.05	1.11	1.17
15-24 (Protection Range)	TC	85 - 105 % of nominal		
	PI	80 - 120 % of nominal		

LEGEND

- TC – Total Heating Capacity, kW
- PI – Power Input, kW
- WB – Wet Bulb Temp., (°C)
- DB – Dry Bulb Temp., (°C)
- ID – Indoor
- OU – Outdoor

5.12.4 Capacity Correction Factors

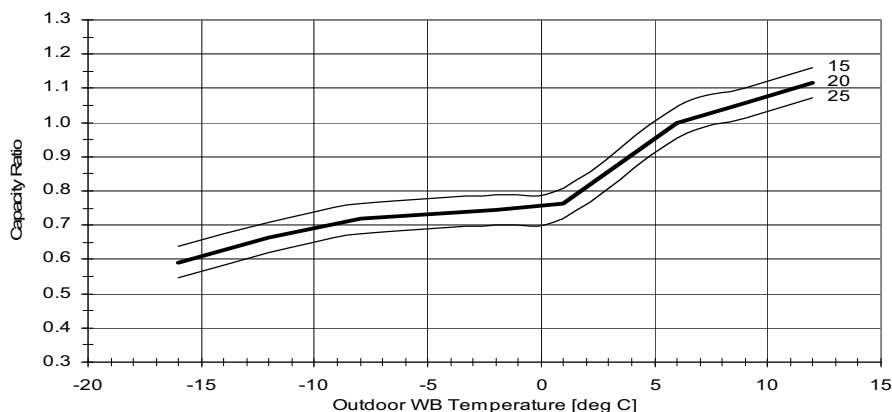

5.13 Tubing Length Capacity Correction Factor (F_T) - one way

5.13.1 Cooling

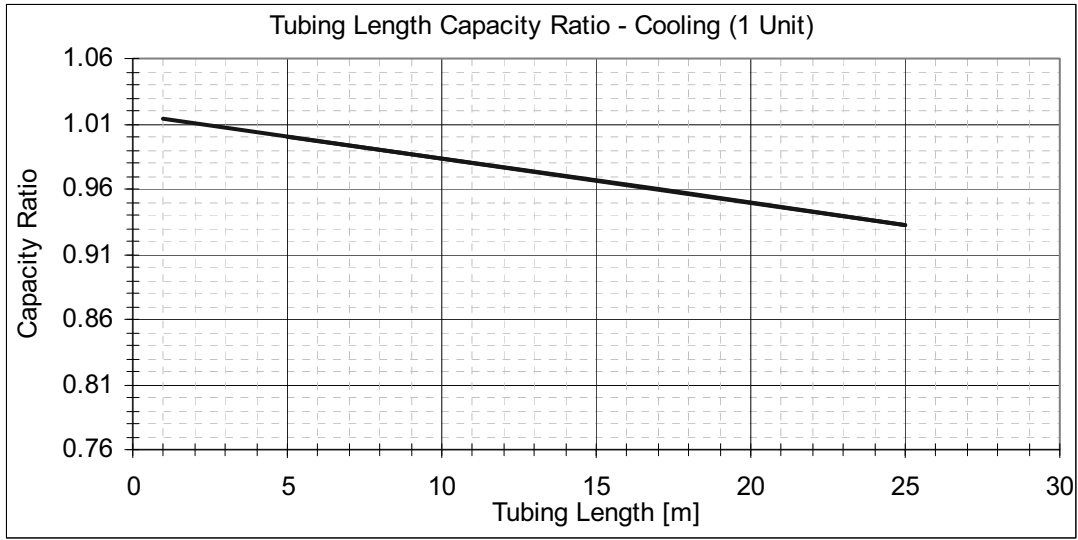

5.13.2 Heating

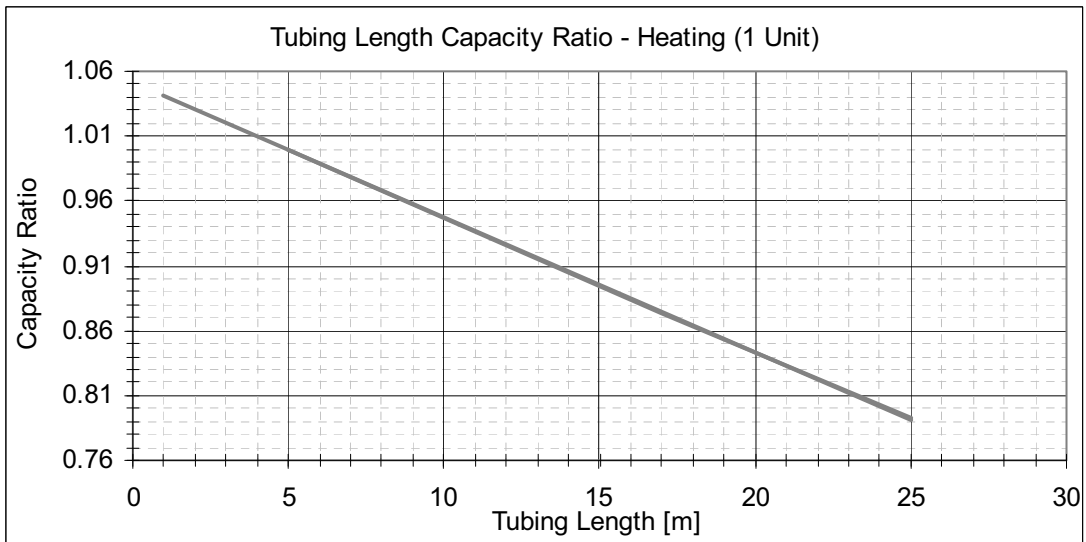

5.14 Model Correction Factors (F_M)

Model	Capacity		Power input	
	Cooling	Heating	Cooling	Heating
FLO DCI	1.00	1.00	1.00	1.00
K DCI	1.03	1.07	1.01	1.10
SX DCI	TBD	TBD	TBD	TBD
BS DCI	TBD	TBD	TBD	TBD

15.15 Calculation Example

Outdoor Unit	Quattro-80 DCI
Indoor Combination	FLO 9+FLO 12+K 12+FLO 18
Operation Mode	Cooling Mode
Conditions Indoor	22°CDB/15°WB
Conditions Outdoor	30°CDB
Tubing length	20m+10m+5m+25m

Cooling Capacity calculation:

$$C_{A-D} \text{ [KW]} = \text{Nominal} \times F_M \times F_C \times F_T$$

$$\text{Total System Capacity [KW] (TC)} = C_A + C_B + C_C + C_D$$

Indoor Unit	Nom' Cooling Capacity [KW]	Model Factor (F_M)	Condition Factor (F_C)	Tubing(L) Factor (F_T)	Corrected Capacity [KW], (C_{A-D})
Room A – FLO 9	1.43	1.00	0.92	0.95	$C_A = 1.43 \times 1.00 \times 0.92 \times 0.95 = 1.25$
Room B – FLO 12	1.91	1.00	0.92	0.985	$C_B = 1.91 \times 1.00 \times 0.92 \times 0.985 = 1.73$
Room C – K 12	1.91	1.03	0.92	1.00	$C_C = 1.91 \times 1.03 \times 0.92 \times 1.00 = 1.81$
Room D – FLO 18	2.87	1.00	0.93	0.93	$C_D = 2.87 \times 1.00 \times 0.93 \times 0.93 = 2.48$
				Total	TC = 1.25 + 1.73 + 1.81 + 2.48 = 7.27

Cooling Power Input calculation:

$$P_{A-D} \text{ [KW]} = \text{Nominal} \times F_M \times F_C \times F_T$$

$$\text{Total System Power Input [W] (TP)} = P_A + P_B + P_C + P_D$$

Indoor Unit	Nom' Cooling Power Input [W]	Model Factor (F_M)	Condition Factor (F_C)	Corrected Power Input [W] (P_{A-D})
Room A – FLO 9	2,410 / 4 = 602.5	1.00	0.88	$P_A = 602.5 \times 1.00 \times 0.88 = 530$
Room B – FLO 12		1.00	0.88	$P_B = 602.5 \times 1.00 \times 0.88 = 530$
Room C – K 12		1.01	0.88	$P_C = 602.5 \times 1.01 \times 0.88 = 535$
Room D – FLO 18		1.00	0.86	$P_D = 602.5 \times 1.00 \times 0.86 = 518$
			Total	TP = 530 + 530 + 535 + 518 = 2,113

6. PRESSURE CURVES

6.1 Model: TRIO-72 DCI

6.1.1 Cooling – Technician Mode

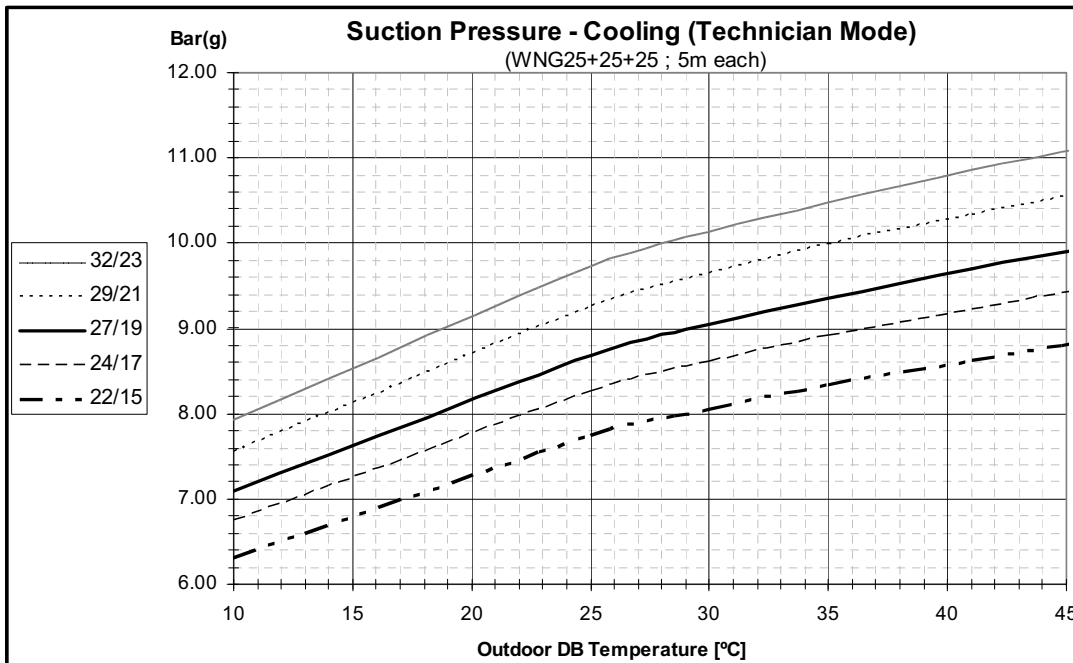
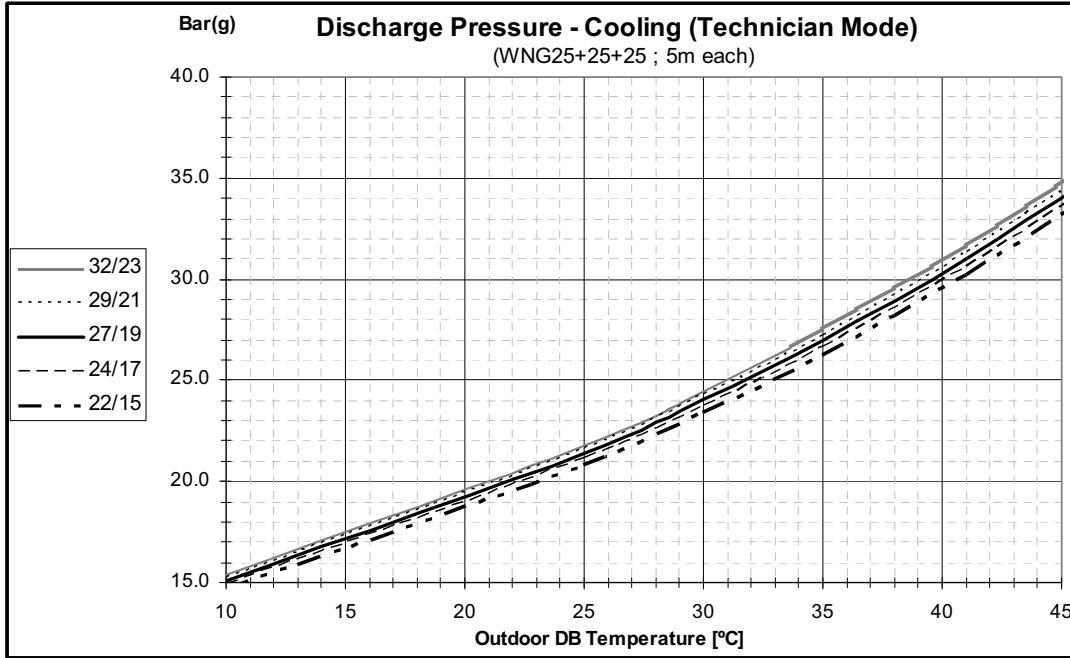

6.1.2 Heating – Technician Mode

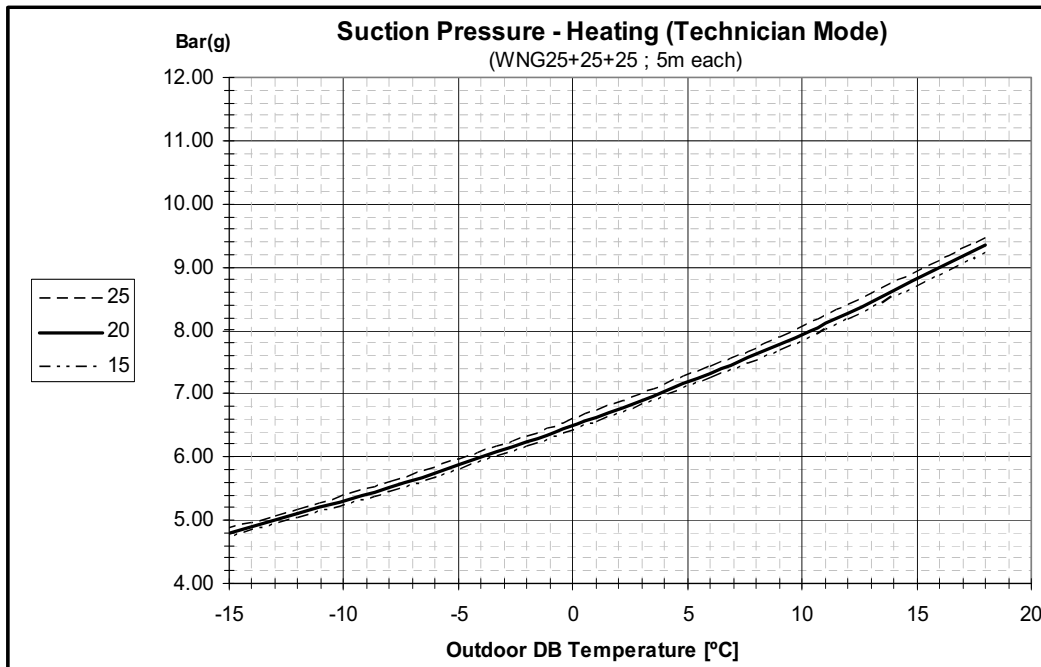
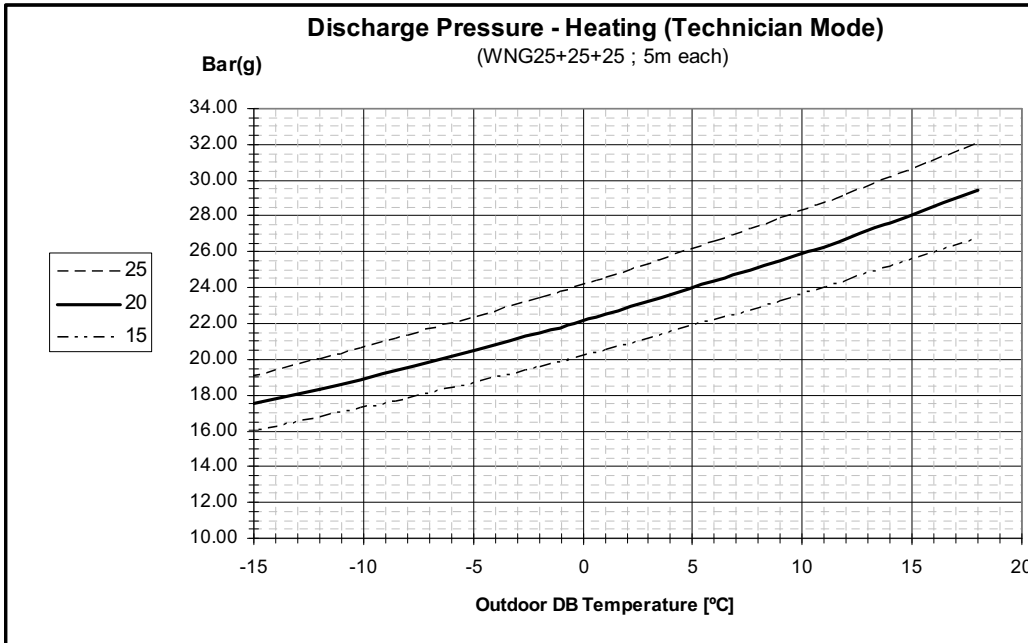

6.1.3 Tubing Length correction Factor

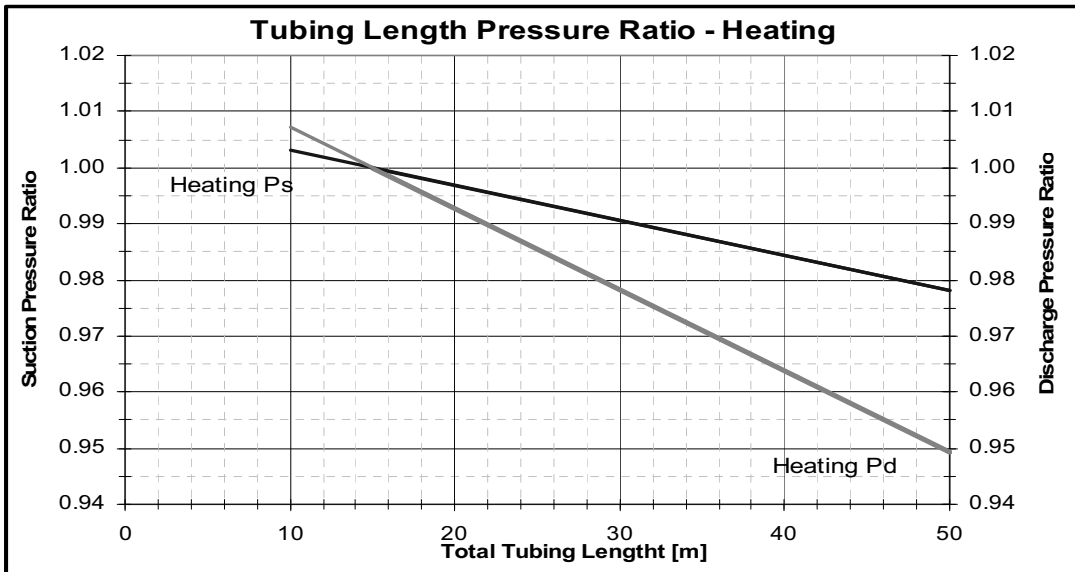
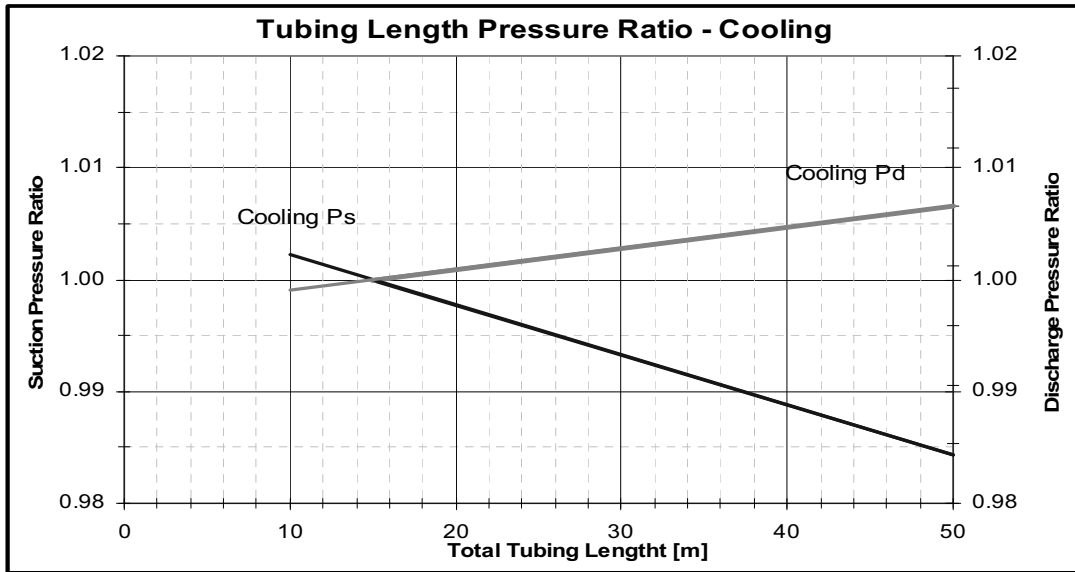

6.1.4 Outdoor Unit Code correction Factor (F_c)

ODU Code	Cooling		Heating	
	Suction Pressure	Discharge Pressure	Suction Pressure	Discharge Pressure
3	1.00	1.00	1.00	1.00
3.5	1.02	1.00	1.00	0.98
4	1.05	1.01	0.99	0.97
4.5	1.07	1.02	0.99	0.95
5	1.09	1.02	0.98	0.93

6.2 Model: QUATTRO-80 DCI

6.2.1 Cooling – Technician Mode

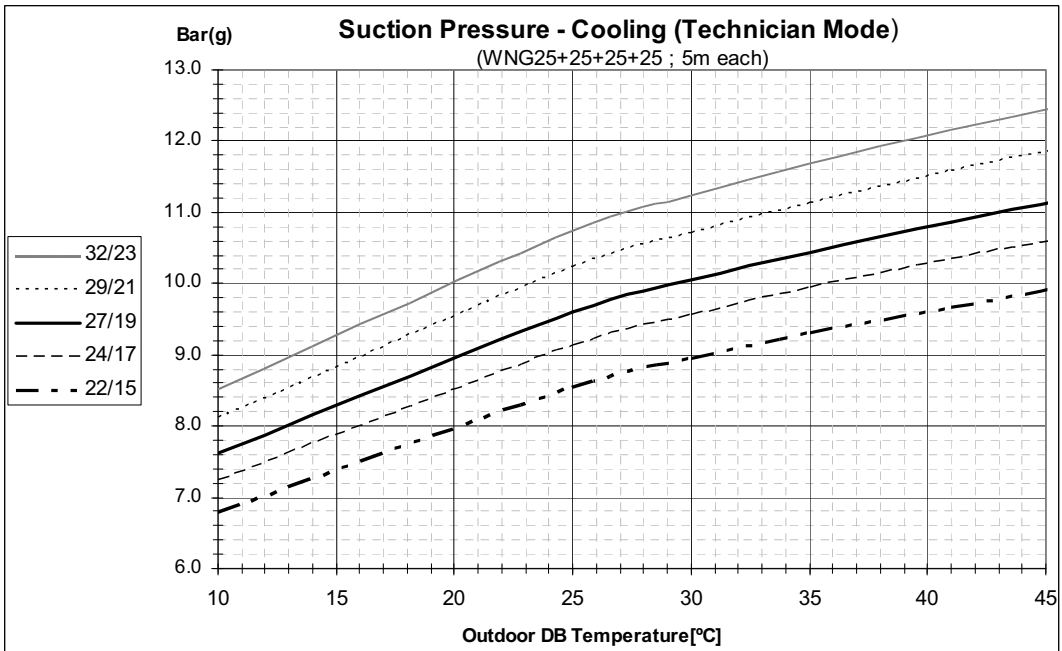
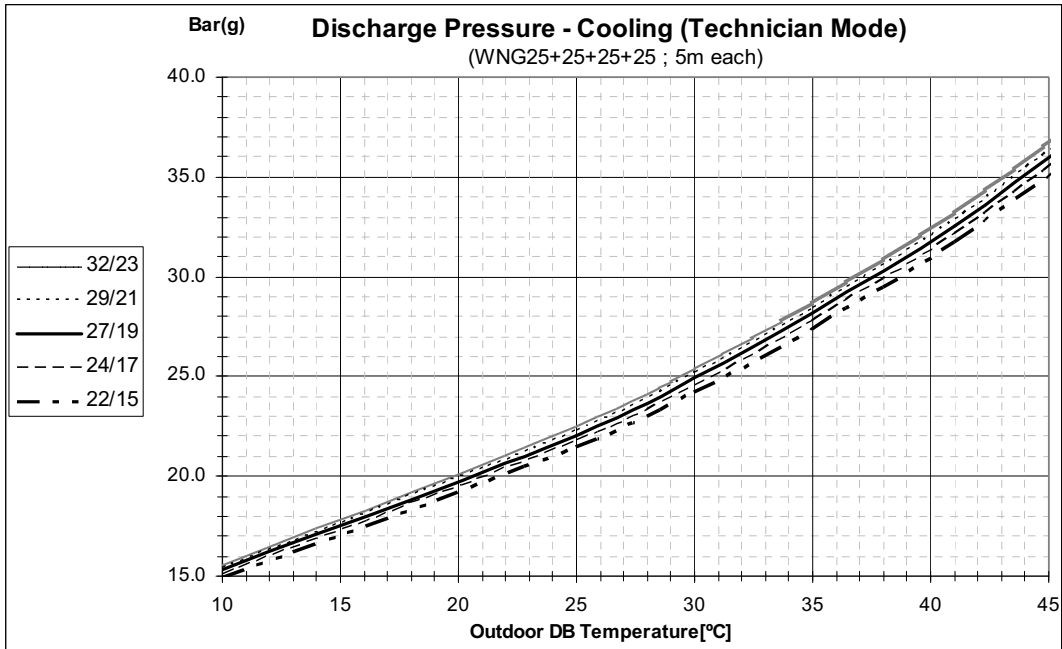

6.2.2 Heating – Technician Mode

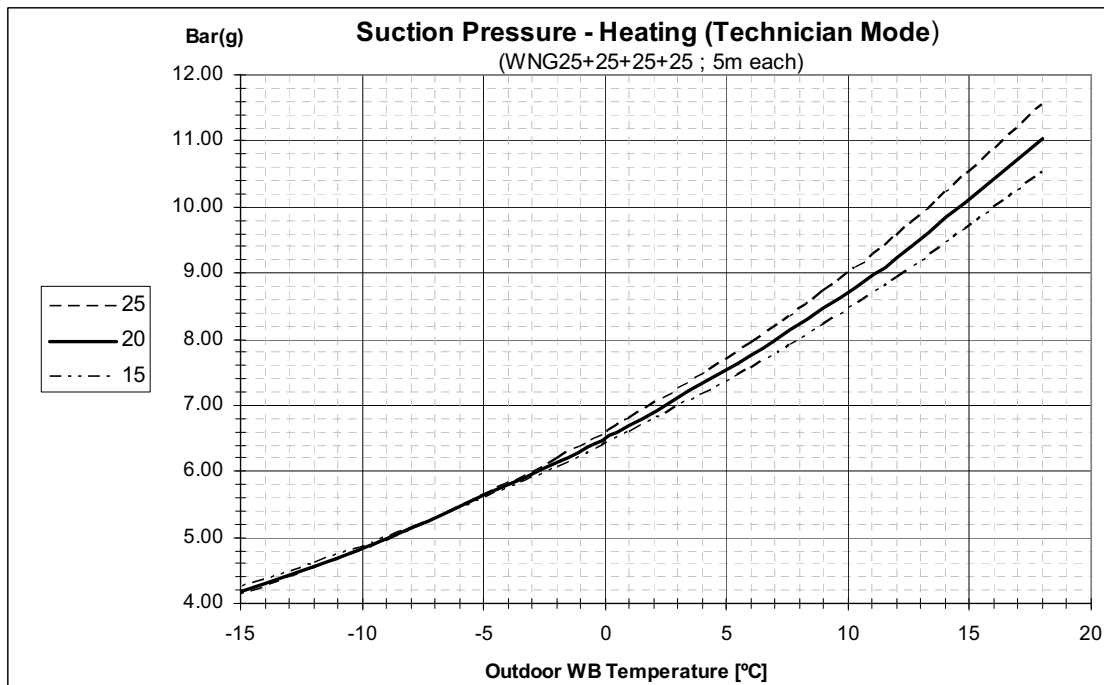
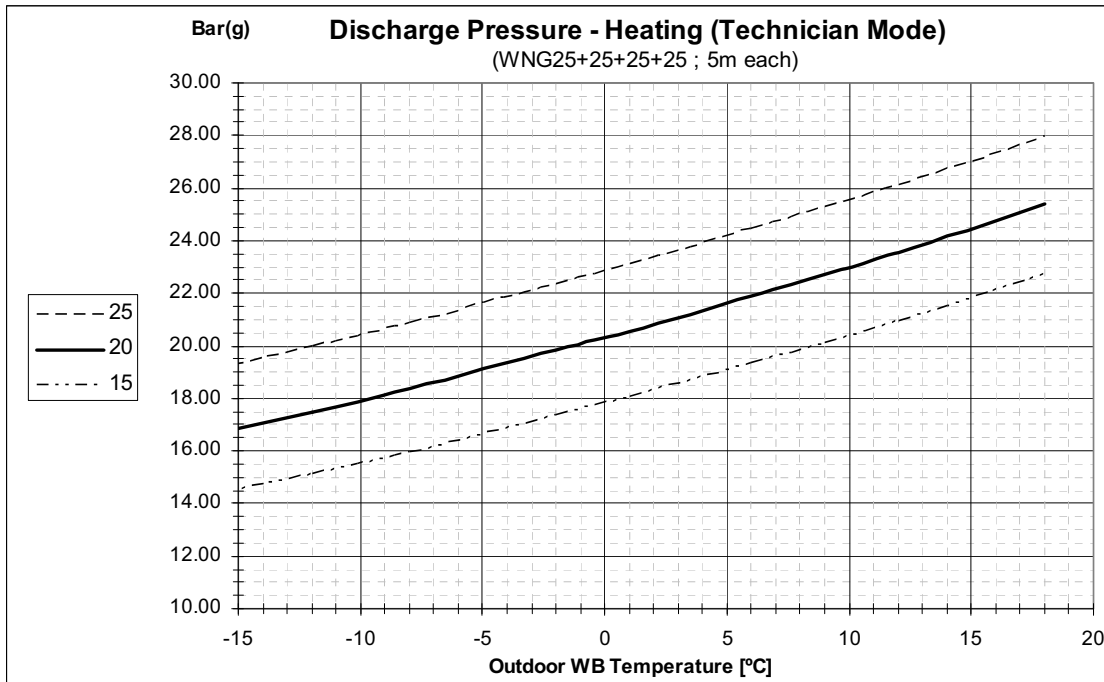

6.2.3 Tubing Length correction Factor (F_T)

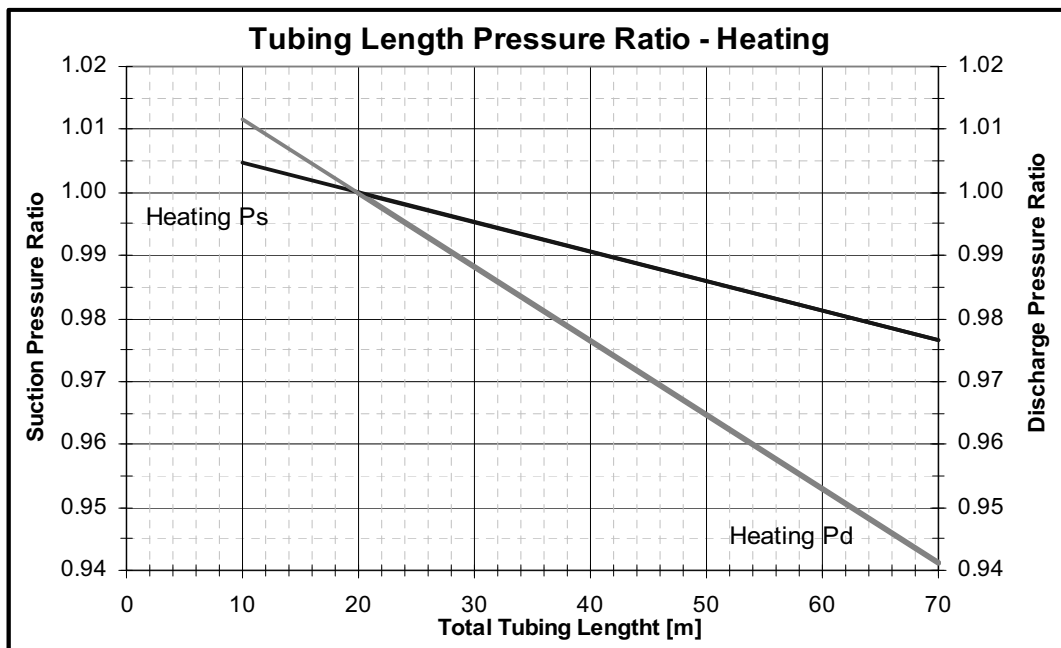
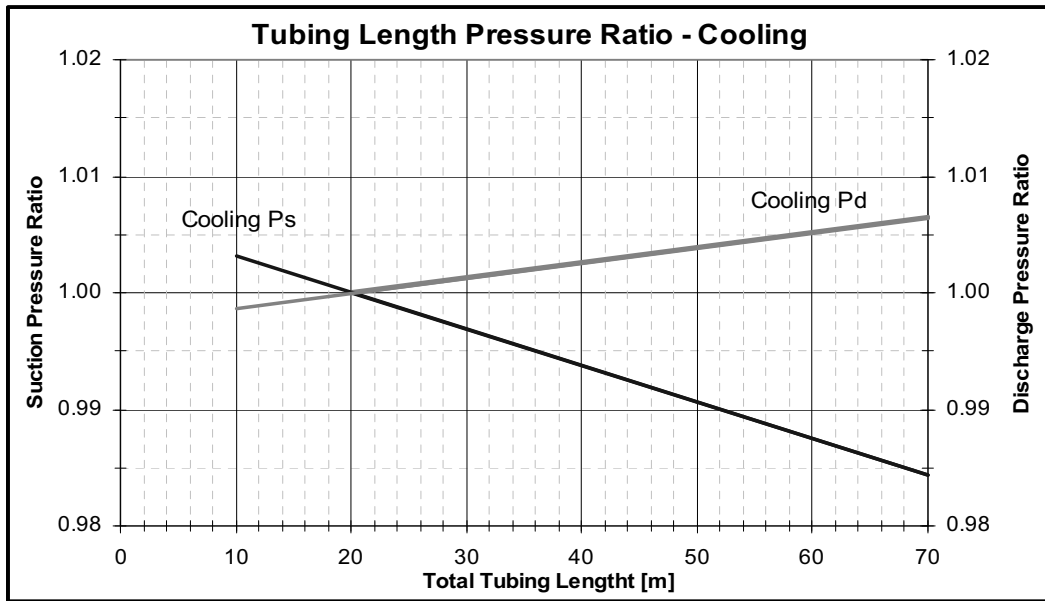

6.2.4 Outdoor Unit Code correction Factor (F_c)

ODU Code	Cooling		Heating	
	Suction Pressure	Discharge Pressure	Suction Pressure	Discharge Pressure
4	1.00	1.00	1.00	1.00
4.5	1.02	1.01	1.00	0.99
5	1.04	1.01	0.99	0.98
5.5	1.05	1.02	0.99	0.97
6	1.07	1.02	0.98	0.96

6.3 Calculation Example

Outdoor Unit	Quattro-80 DCI
Indoor Combination	FLO 9+FLO 12+K 12+FLO 18
Operation Mode	Cooling Mode
Conditions Indoor	22°CDB/15°WB
Conditions Outdoor	30°CDB
Tubing length	20m+10m+5m+25m = 60m

Cooling Pressure calculation:

Pressure [Barg] = Nominal x F_c x F_T

Unit	Code
Room A – FLO 9	1.0
Room B – FLO 12	1.5
Room C – K 12	1.5
Room D – FLO 18	2.0
ODU Code (Total)	6.0

Nominal Pressure [Barg]		ODU Code Factor (F_c)	Tubing (L) Factor (F_T)	Corrected Pressure [Barg]
Discharge	24.5	1.02	1.005	Pd= 24.5 x 1.02 x 1.005 = 25.11
Suction	9.0	1.07	0.988	Ps= 9.0 x 1.07 x 0.988 = 9.51

7. ELECTRICAL DATA

7.1 Trio-72, Quattro-80 DCI

Power Supply	1 PH, 220-240 VAC, 50Hz
Connected to	Outdoor
Maximum Current	16 A
Inrush Current	35 A
Starting Current	11 A
Circuit breaker	20 A
Power supply wiring - No. x cross section	3 X 2.5 mm ²
Interconnecting cable - No. x cross section	4 X 1.5 X 1.5 mm ² (For each IDU)

Note:

- Inrush current is the current when power is up. (charging the DC capacitors at outdoor PCB).
- Starting current is the current at comp; start up.

NOTE

Power wiring cord should comply with local laws and electrical regulations requirements.

8. WIRING DIAGRAMS & ELECTRICAL CONNECTIONS

8.1 Outdoor Units: TRIO-72, QUATTRO-80 DCI

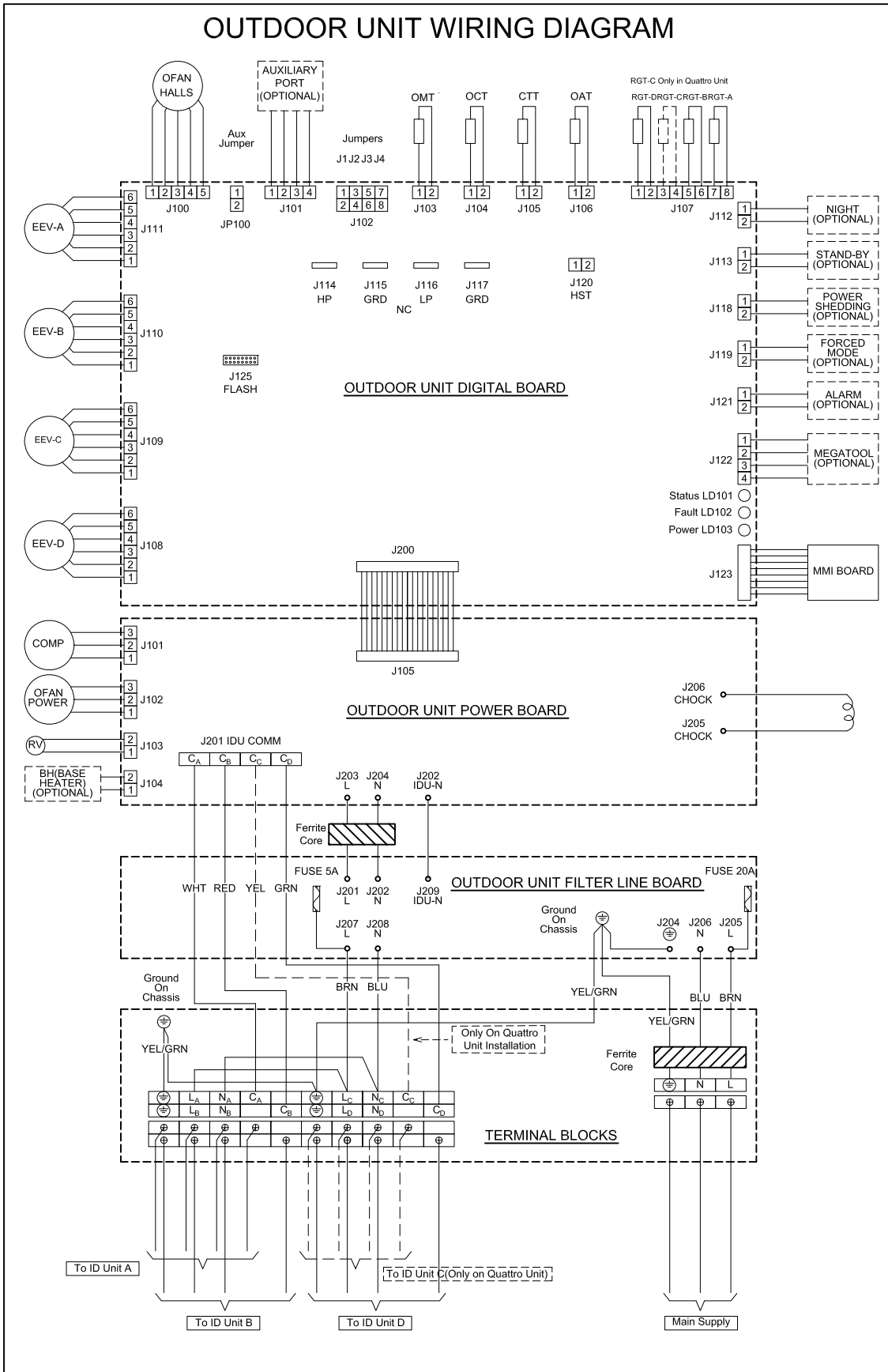

8.2 Outdoor Units: TRIO-72, QUATTRO-80 DCI

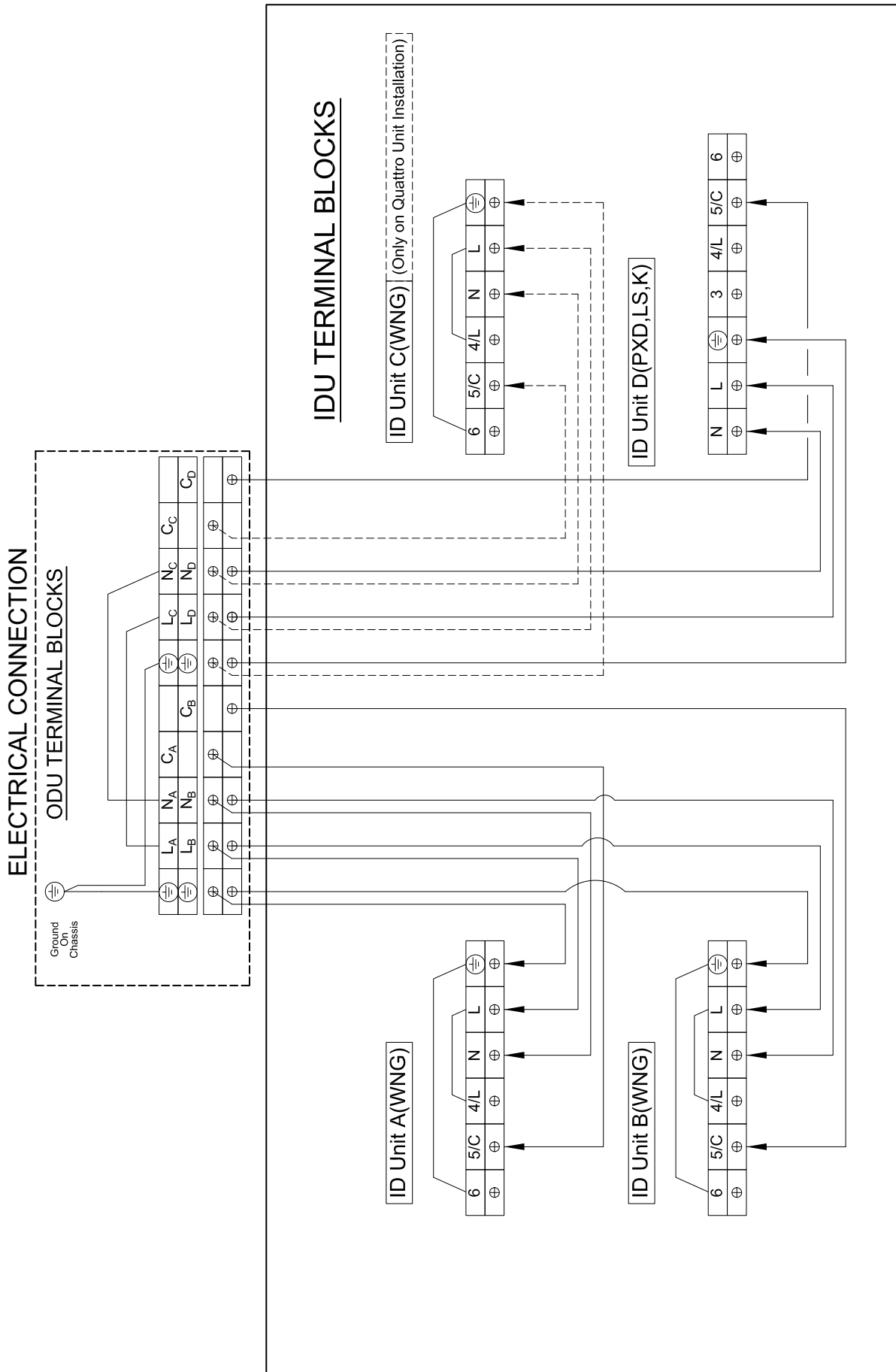

9. REFRIGERATION DIAGRAMS

9.1 TRIO-72 DCI, QUATTRO-80 DCI

Outdoor Unit Refrigerant System Diagram

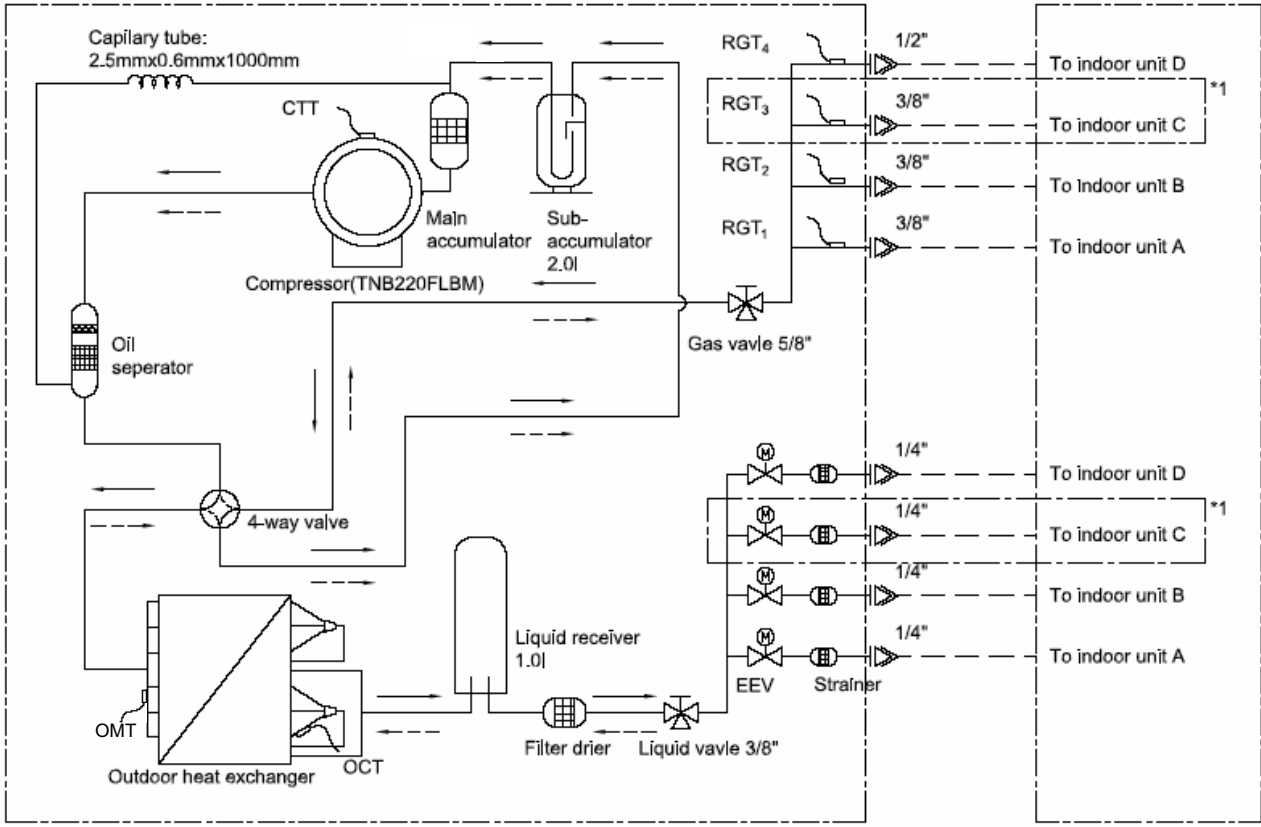

OUTDOOR UNIT

INDOOR UNIT

NOTE:*1:There is no C unit in Trio-72 DCI
 —→ Refrigerant flow(Cooling)
 - - - - Refrigerant flow(Heating)

10. TUBING CONNECTIONS

Outdoor Unit

Indoor Unit

- (A) Suction line
- (B) Liquid line
- (C) Flare nut
- (D) Pipe insulation
- (E) Insulating sleeve

Tube bending

$R \geq 3.5\phi$

TUBE (Inch)	1/4"	3/8"	1/2"	5/8"	3/4"
TORQUE (Nm)					
Flare Nuts	11-13	40-45	60-65	70-75	80-85
Valve Cap	13-20	13-20	18-25	18-25	40-50
Service Port Cap	11-13	11-13	11-13	11-13	11-13

1. Valve Protection Cap-end
2. Refrigerant Valve Port (use Allen wrench to open/close)
3. Valve Protection Cap
4. Refrigerant Valve
5. Service Port Cap
6. Flare Nut
7. Unit Back Side
8. Copper Tube

11. CONTROL SYSTEM

11.1 Abbreviations

Abbreviation	Definition
A/C	Air Condition
BMS	Building Management System
PWR	System Power
CTT	Compressor Top Temperature sensor
DCI	DC Inverter
EEV	Electronic Expansion Valve
HE	Heating Element
HMI	Human Machine Interface
HST	Heat Sink Temperature sensor
Hz	Hertz (1/sec) – electrical frequency
ICT	Indoor Coil Temperature (RT2) sensor
IDU	Indoor Unit
MCU	Micro Controller Unit
OAT	Outdoor Air Temperature sensor
OCT	ODU Coil Temperature sensor
ODU	Outdoor Unit
OFAN	Outdoor Fan
PFC	Power Factor Corrector
RAC	Residential A/C
RC	Reverse Cycle (Heat Pump)
RGT	Return Gas Temperature sensor
RPS	Rounds per second (mechanical speed)
RV	Reverse Valve
SB,STBY	Stand By
OMT	Middle Outdoor Coil Temperature
S/W	Software
TBD	To Be Defined
TMR	Timer

11.2 Product Overview

11.2.1 Block Diagram

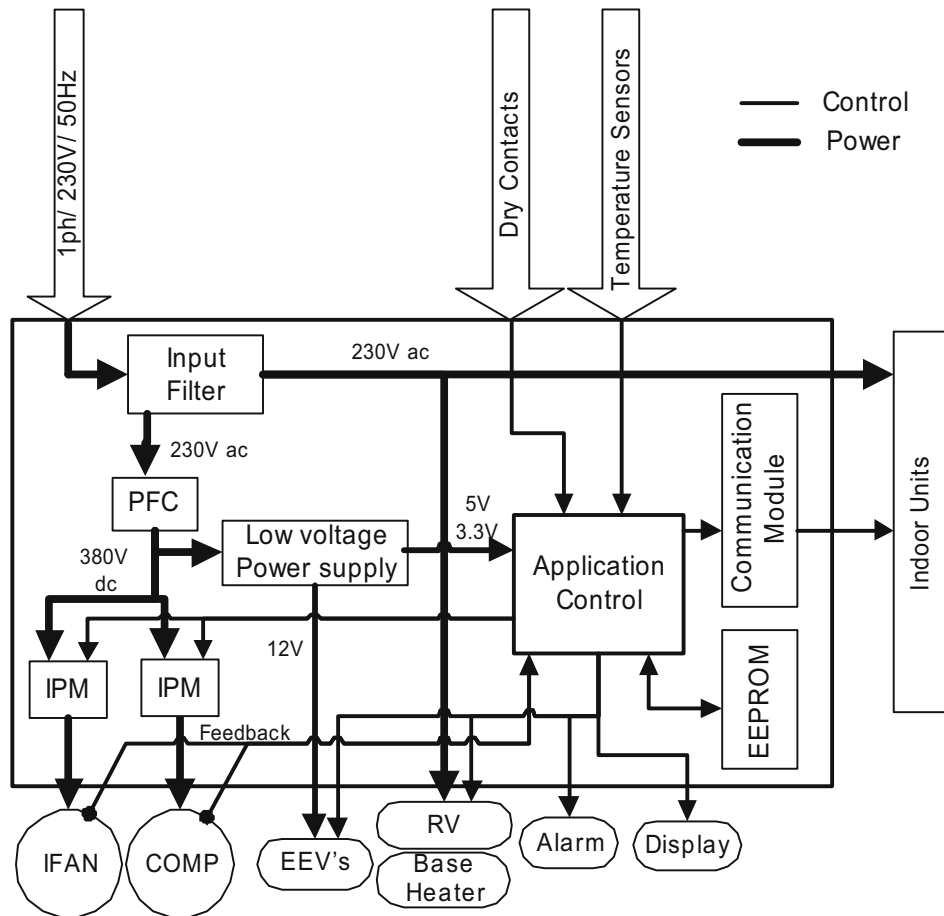

11.2.2 Compressor

DC brush less and sensor less 2.5/3 horsepower motor inverter driven compressor.

11.2.3 Outdoor Fan

DC brush less motor.

11.2.4 RV

Reverse Valve set the direction of refrigerant flow in the system, thus setting the operation mode for cooling or heating.

When the solenoid is powered, system will work in heat mode.

11.2.5 EEV's

Expansion valve operated by step motor which controls the size of the orifice.

11.2.6 HMI

Three "7-Segments" + four Push buttons

11.2.7 Dry Contacts

Dry contacts are used to interface the system with an external building management system (BMS).

- **Night** input. Switches the system to night mode when closed.
During night mode, the outdoor unit speed will be reduced in order to reduce the system noise level.
- **SB** input. System will be turned to Stand-by when the contact is closed.
- **Power Shedding** input. Limits the maximum power consumption when closed.
- **Forced Mode** input. Used to force the operation mode of the system
- **Alarm** output indicates a failure at the system.

Alarm output will be activated when there in the following ODU Faults/Protections 1 to 6, 8 to 22, 24, 25, 27 and 28.

Alarm output will be OFF when the Fault/Protection is cleared.

11.2.8 Temperature Sensors

CTT – Compressor Top Temperature

OAT – Outdoor Air Temperature

OMT – Outdoor Middle Coil Temperature

OCT – Outdoor Coil (heat exchanger) Temperature

HST – Heat Sink Temperature

RGT1..4 – Indoor Unit 1..4 Returned Gas Temperatures

11.2.9 Base Heater

Heating element designed to melt any ice that is accumulated on the outdoor unit base during low heating operation.

11.3 General Operating Rules

11.3.1 Initialization

Initialization process is the first operation done each time power is up. The targets of the initialization are:

- Addressing of IDU's
- Identification of connected IDU's
- IDU Matching Check
- EEV's homing (reset position)
- Restoring Parameters from EEPROM/Jumpers/Dipswitches

11.3.1.1 IDU's Initialization

11.3.1.1.1 Capacity Codes Setting

The capacity groups of the IDU's are translated into capacity codes according to the following table:

Capacity group	Capacity Code
0 (2.0 - 2.9kw)	1.2
1 (3.0 - 3.9kw)	1.5
2 (4.0 - 4.9kw)	Reserved
3 (5.0 to 60)	2
4 (6.1kw and above)	3

11.3.1.1.2 IDU Matching Check

The following procedure comes to verify that the total capacity of connected indoor units is suitable for the capacity of the outdoor, and that indoor units with a large capacity are connected to the channels with EEV and refrigerant tubing that is suitable for large capacities.

- ❖ Compare IDU's family and capacity code to the values stored at the EEPROM.
- ❖ If more then one IDU is connected (multi split application), the following items

should be checked:

- Code_A ≤ 1.5
- Code_B ≤ 1.5
- Code_C ≤ 1.5
- Code_D ≤ 2
- The sum of IDU codes ≤ ODUCodeLimit

11.3.1.1.3 IDU's Initialization Faults Definition and System Response

	Fault	Activity	Fault Display	System response
❖	Missing IDU	Update new IDU status stored at the EEPROM.	System configuration Changed	
❖	Change in IDU Family/Capacity Group	Fault will be stored in EEPROM as an inactive failure of the specific IDU	System configuration Changed	
❖	IDU Code Exceed Limit	Fault will be stored in EEPROM for the specific IDU	System Configuration Problem	System will switch to SB
❖	Total IDU Code Exceed Limit	ODU fault will be stored in EEPROM	System Configuration Problem	System will switch to SB

11.3.2 Communication with Indoor Units

11.3.2.1 Communication Failures Definition

Two types of communication failures are diagnosed. The communication failures are checked separately for each IDU channel.

11.3.2.1.1 'Bad Communication' fault

The system keeps a balance of a good/bad communication packet ratio for each active communication channel. When the ratio getting high , system enters 'Bad Communication' fault.

11.3.2.1.2 'No Communication' fault

If no legal transmission or no message received for 30 seconds, system enters 'No Communication' fault.

When in 'No Communication' fault, the system will act as following:

- If there is no communication in all channels, the following will be performed:
 1. The unit changes to SB.
 2. The system will scan all the communication.
 3. Each channel that is identified as 'no communication' channel will be referred as STBY unit.
 4. The unit resumes its normal operation with only the operative channels.

11.3.3 Temperature Measurements

11.3.3.1 Thermistor failures definition

Thermistor	Thermistor is Disconnected	Thermistor is Shorted
OCT	Temp < -40 °C	Temp > 75 °C
OAT	Temp < -40 °C	Temp > 75 °C
CTT	Temp < -30 °C	Temp > 130 °C
OMT	Temp < -40 °C	Temp > 75 °C
HST	Temp < -30 °C	Temp > 130 °C
RGT	Temp < -40 °C	Temp > 75 °C

11.3.3.2 System responses for different thermistor failure

Thermistor	Default value	System Reaction
OCT	6°C	
OAT	Cool 35°C Heat 7°C	
CTT	43°C	Forced compressor to OFF after 20 minutes.
OMT	6°C	
HST	43°C	
RGT	43°C	
ICT	43°C	

11.3.4 Flash Memory Programming

In order to upgrade the ODU software the auxiliary port will be used. A special application should be run on a PC to transmit the new firmware.

11.4 Indoor Unit Control

11.4.1 Indoor Fan Control

10 Indoor fan speeds are determined for each model. 5 speeds for each mode cool/dry/fan or heat.

When user sets the indoor fan speed to a fixed speed (Low/ Medium/ High), unit will operate constantly at set speed.

When Auto Fan is selected, indoor unit controller can operate in all speeds. The actual speed is set according to the cool/heat load.

11.4.1.1 Turbo Speed

The Turbo speed is activated during the first 30 minutes of unit operation when auto fan speed is selected and under the following conditions:

Difference between set point and actual room temperature is higher than 3 degrees.

Room temperature is higher than 22°C for cooling or less than 25°C for heating.

11.4.2 Cool Mode

NLOAD is calculated according to the difference between actual room temperature and user set point temperature by PI control.

In high/ medium/ low indoor fan user setting, unit will operate fan in selected speed.

In AutoFan user setting, fan speed will be adjusted automatically according to the calculated NLOAD.

11.4.3 Heat Mode

NLOAD is calculated according to the difference between actual room temperature and user set point temperature by PI control.

In high/ medium/ low indoor fan user setting, unit will operate fan in selected speed.

In AutoFan user setting, fan speed will be adjusted automatically according to the calculated NLOAD.

11.4.3.1 Temperature Compensation

In wall mounted, ducted, and cassette models, 3 degrees are reduced from room temperature reading (except when in I-Feel mode), to compensate for temperature difference between high and low areas in the heated room, and for coil heat radiation on room thermistor.

The temperature compensation can be enabled/disabled by shortening of J2 on the indoor unit controller.

Model	J2 Shorted	J2 Opened
Wall mounted	Compensation Disabled	Compensation Enabled
Cassette	Compensation Enabled	Compensation Disabled
Ducted	Compensation Enabled	Compensation Disabled
Floor/Ceiling	Compensation Disabled	Compensation Enabled

11.4.3.2 Indoor Fan Control in Heat Mode

Indoor fan speed depends on the indoor coil temperature:

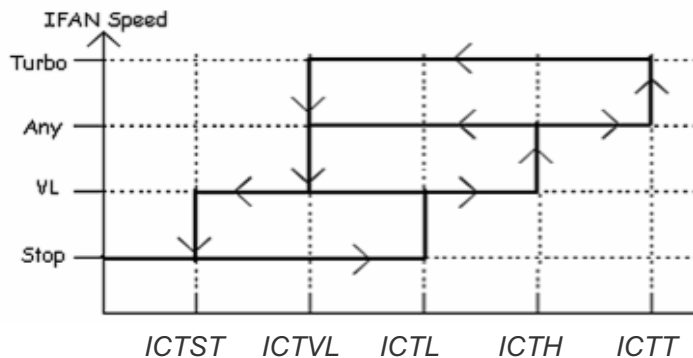

11.4.4 Auto Cool/Heat Mode

When in auto cool heat mode unit will automatically select between cool and heat mode according to the difference between actual room temperature and user set point temperature (ΔT).

Unit will switch from cool to heat when compressor is off for 3 minutes, and $\Delta T < -3$.

Unit will switch from heat to cool when compressor is off for 5 minutes, and $\Delta T < -3$.

11.4.5 Dry Mode

As long as room temperature is higher than the set point, indoor fan will work in low speed and compressor will work between 0 and *MaxNLOADIF1C* Hz.

When the room temperature is lower than the set point, compressor will be switched OFF and indoor fan will cycle 3 minutes OFF, 1 minute ON.

11.4.6 Indoor Units Operation when Indoor Unit Mode is Different than Outdoor Unit Mode

- Open louvers according to user selection.
- Indoor fan is forced to OFF.

11.4.7 Heating Element Control

Heating element can be lit on if $LOAD > 0.8 * MaximumNLOAD$ AND Indoor Coil temperature $< 45^{\circ}C$.

The heating element will be off when $LOAD < 0.5 * MaximumNLOAD$ OR if Indoor Coil temperature $> 50^{\circ}C$.

11.4.8 Ioniser Control

WNG Family - Ioniser is on when unit is on AND indoor fan is on AND Ioniser power switch (on Ioniser) is on.

11.4.9 Electro Static Filter (ESF) Control

WNG Family - ESF is on when ESF switch is on, Safety switch is pressed, unit is on, AND indoor fan is on.

11.4.10 Indoor Unit Dry Contact

Indoor unit Dry contact has two alternative functions that are selected by J8.

Status	Function	Contact = Open	Contact = Short
J8 = Open	Presence Detector Connection	No Limit	Forced to STBY
J8 = Short	Power Shedding Function	No Limit	Limit NLOAD

11.4.11 Operating the Unit from the Mode Button

Forced operation allows to start, stop and operate in Cooling or Heating, in pre-set temperature according to the following table:

Forced operation Mode	Pre-set Temperature
Cooling	20°C
Heating	28°C

11.4.12 On Unit Controls and Indicators

11.4.12.1 All Models Except for Floor/Ceiling model

STAND BY INDICATOR	Lights up when the Air Conditioner is connected to power and ready to receive the R/C commands
OPERATION INDICATOR	Lights up during operation. Blinks for 300 msec to announce that a R/C infrared signal has been received and stored. Blinks continuously during protections (according to the relevant spec section).
TIMER INDICATOR	Lights up during Timer and Sleep operation.
FILTER INDICATOR	Lights up when Air Filter needs to be cleaned.
COOLING INDICATOR	Lights up when system is switched to Cool Mode by using the Mode Switch <u>on the unit</u> .
HEATING INDICATOR	Lights up when system is switched Heat Mode by using the Mode Switch <u>on the unit</u> .
Mode SWITCH (COOL/HEAT/OFF)	Every short pressing , the next operation mode is selected, in this order : SB → Cool Mode → Heat Mode → SB → ... In long pressing system enters diagnostic mode.
RESET / FILTER SWITCH	For short pressing: When Filter LED is on - turn off the FILTER INDICATOR after a clean filter has been reinstalled. When Filter LED is off – enable/disable the buzzer announcer, if selected.

11.4.12.2 CD Display

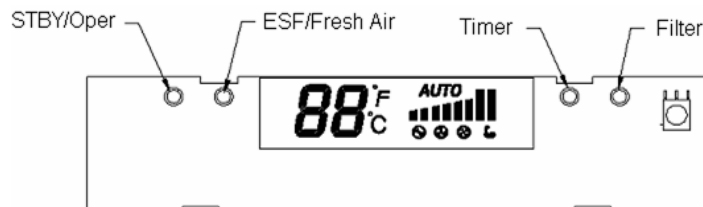

	STBY	Cool	Heat	Auto	Fan	Dry
	OFF	SPT	SPT	SPT	SPT	SPT
	OFF	ON	ON	ON	ON	ON
	OFF	OFF	OFF	OFF	OFF	OFF
(Low)	OFF	User setting IFAN speed	User setting IFAN speed	User setting IFAN speed	User setting IFAN speed	User setting IFAN speed
(Med)	OFF					
(High)	OFF					
(Turbo)	OFF					
(Auto)	OFF					
Backlight(red)	OFF	OFF	ON	ON	ON	OFF
Backlight(green)	OFF	ON	OFF	ON	ON	ON

11.4.12.3 Floor/Ceiling Model

STANDBY INDICATOR	Lights up when the Air Conditioner is connected to power and is ready for operation
OPERATE INDICATOR	1. Lights up during operation. 2. Blinks for 300 msec to announce that a R/C infrared signal has been received and stored. 3. Blinks continuously during protections (according to the relevant spec section).
TIMER INDICATOR	Lights up during Timer and Sleep operation.
FILTER INDICATOR	1. Lights up when Air Filter needs to be cleaned. 2. Blinks during Water Over Flow in PXD models. (Cf. Sect. 7.3)
COOLING INDICATOR	Lights up when system is switched to Cool Mode by using the Mode Switch <u>on the unit</u> .
HEATING INDICATOR	Lights up when system is switched Heat Mode by using the Mode Switch <u>on the unit</u> .
FAN MODE INDICATOR	Lights up in Fan Mode activated by <u>local switches</u> .
FAN SPEED INDICATORS	L -- Lights up when IFAN setting is Low. M -- Lights up when IFAN setting is Medium. H -- Lights up when IFAN setting is High. A -- Lights up when IFAN setting is Auto.
TEMP. SETTING INDICATORS	Each one of the seven indicators indicates the following SPT: 18, 20, 22, 24, 26, 28, 30 [°c]. The odd number temperatures are indicated by turning on the two adjacent indicators.
FAN SPEED BUTTON	Press this button to change the speed of the IFAN. Each pressing change the speed in the sequence of: ... L → M → H → Auto → L → ...
TEMP. SETTING UP BUTTON	Pressing this button increases the SPT by 1°C. Note: The Max SPT is 30°C.
TEMP. SETTING DOWN BUTTON	Pressing this button decreases the SPT by 1°C. Note: The Min SPT is 18°C.
MODE BUTTON	Every short pressing , the next operation mode is selected, in this order :SB → Cool Mode → Heat Mode → SB → ... In long pressing system enters diagnostic mode.
POWER BUTTON	Toggle the unit between OPER & STBY modes.
RESET / FILTER BUTTON	For short pressing: When Filter LED is on - turn off the FILTER INDICATOR after a clean filter has been reinstalled. When Filter LED is off – enable/disable the buzzer announcer, if selected. In long pressing system enters set up mode (if in SB).

11.5 Run Mode

Run mode is the default operation mode of the system. This is the standard operation mode that is active in field application (at customer site).

System can go from run mode to other operation modes through keyboard or serial ports.

11.5.1 Mode Setting

Mode defines the ODU operation mode. There are three possible operation modes:

1. STBY – standby mode
2. COOL - the unit operating at cooling cycle
3. HEAT - the unit operating at heat pump cycle

The ODU define the system operation mode according to three methods set by the display key board:

1. First request priority

The first IDU which requests different mode than STBY mode will set the new operation mode. The mode will change once all the units exit the current operation mode.

2. Priority unit

If an IDU is defined as a priority unit, the operational mode will be defined according to that unit request, unless the unit is at STBY mode.

In case priority unit is SB the mode will be set according to first request priority.

3. Forced operation mode

If forced mode is enabled than the ODU mode will be forced according to the Forced mode input:

Open → COOL

Short → HEAT

The ODU will go to SB if all the IDU are at SB or at different modes.

4. SB Input

The ODU will change mode between COOL/HEAT and Idle according to the STBY dry contact input as follows:

STBY input	ODU mode
Short	SB
Short → Open	last mode
Open	according normal mode selection

11.5.2 Compressor Speed Control

11.5.2.1 Compressor Min On/Off time

Compressor minimum OFF time is MinOFFTime minutes except during Deicing protection. Compressor minimum ON time is MinOnTime minutes, minimum ON time is ignored during protections, and when unit is turned to STBY.

11.5.2.2 Compressor Speed calculation

During normal operation (excluding protections), the compressor speed is limited by the minimum speeds according to the number of the active IDU units:

# of active IDU units	Min Speed Cool	Max Speed Cool	Min Speed Heat	Max Speed Heat
1	15	75	15	95
2	15		20	
3	20		30	
4	30		40	

11.5.2.3 Indoor Units NLOAD calculation

The NLOAD setting is done by the indoor unit controller, based on a PI control scheme. The actual NLOAD to be sent to the outdoor unit controller is based on the preliminary LOAD calculation, the indoor fan speed, and the power shedding function.

NLOAD limits as a function of indoor fan speed:

Indoor Fan Speed	Maximum NLOAD Cooling	Maximum NLOAD Heating
Low	Max NLOADIF1C	127
Medium	Max NLOADIF2C	127
High	Max NLOADIF3C	127
Turbo	Max NLOADIF4C	127
Auto	Max NLOADIF5C	127

NLOAD limits as a function of power shedding:

Mode	Power Shedding OFF	Power Shedding ON
Cool	No limit	Nominal Cooling
Heat	No limit	Nominal Heating

11.5.2.4 Outdoor Unit NLOAD calculation

ODU NLOAD is the weighted average of the active IDU NLOADs:

$$ODU\ NLOAD = \frac{\sum IDU\ NLOAD_i \cdot Code_i}{ODU\ Code}$$

ODU code is defined as following:

Unit type	ODU code Cool	ODU code Heat
Trio	2.8	2.7
Quattro	3.0	2.7

The code for heat mode is related also to outdoor temperature and so in low heating conditions the compressor speed will be higher.

Compressor speed will be set between the minimum speed and the max speed according to the ODU NLOAD

11.5.2.5 Speed Step Limitations

11.5.2.5.1 Step 1 and step 2

The compressor speed cannot go below Step1RPS or above Step2RPS during 3 continuous minutes once after the compressor starts up when the ODU unit changes from STBY

11.5.2.5.2 Step 3 limit

The speed cannot go higher than Step3RPS unless it was operating for more than 1 continuous minute between Step3RPS – 5 and Step3RPS.

11.5.3 EEV Control

11.5.3.1 Operation Range

The EEV operation range is defined according to the operation mode as following

ODU Mode	Normal operation	IDU inactive	Compressor off
SB	200		200
COOL	80 to 350	0	
HEAT	70 to 400	60 to 140	

11.5.3.2 Reaching target value rules

For all cases except at EEV initialization procedure, each EEV can move no more than 20 steps at a time.

When required the EEV's move, one by one in sequence, till the target position is achieved for every EEV.

The following diagram presents the EEV steps till the target position is set.

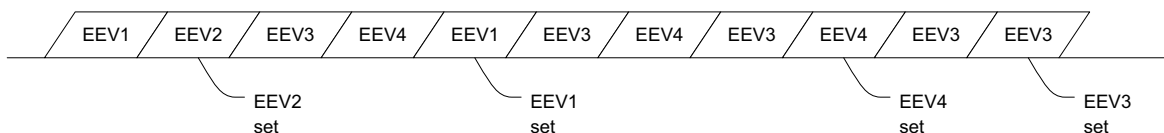

11.5.3.3 EEV Operation when ODU changes to SB Mode

When the ODU mode is changed to SB, the following is performed immediately:

- All EEV's are set to 200.
- They remain in this position for 60 Sec.
- Then, performs reset (*homing*) procedure.

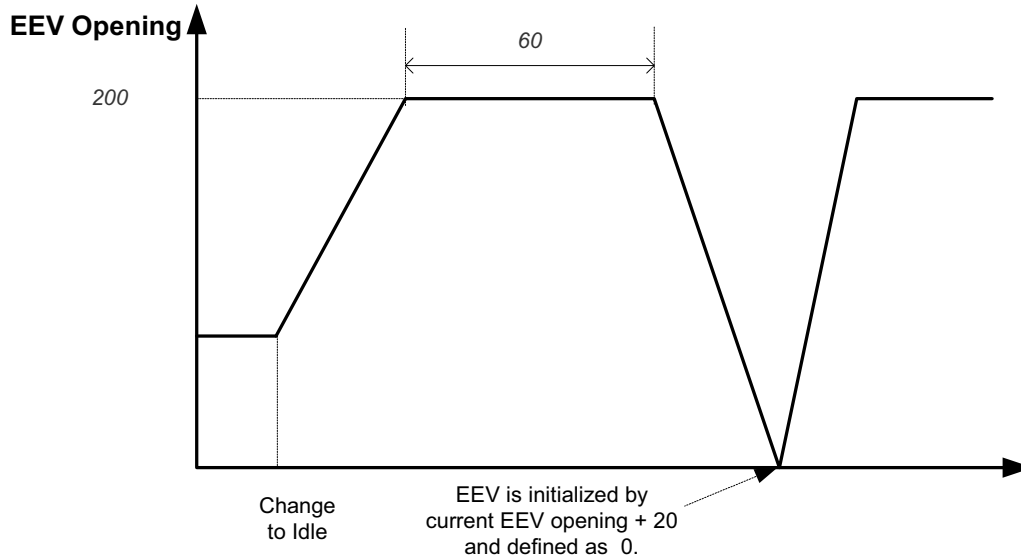

11.5.3.4 EEV Opening Determination

The target EEV value is the sum of open loop value (OL) and a result of the accumulative correction values (CV).

$$EEV_i = EEV_{OLi} + \sum EEV_{CVi}$$

EEV_i is the EEV opening for each 'i' IDU.

11.5.3.5 EEV initial value determination

The EEV initial value (open loop) is determined according to the number of the active indoor units, mode, and the capacity code of the unit.

Basic EEV open loop					Open Loop correction	
Mode	# of active IDU units				IDU Capacity Code	
	1	2	3	4	1.5	2
COOL	220	200	170	150	10	25
HEAT	210	190	150	130	20	40

11.5.3.6 Balance time

During the first 6 minutes after SB the correction is not calculated. After that the correction value is updated every 30 seconds.

11.5.3.7 EEV corrections

The corrections in cool mode will keep the compressor in the proper operation temperature and will balance between the indoor units by controlling their super heat.

11.5.3.8 Accumulative correction value storage

For each combination of active IDUs, the accumulated EEV correction value (for each IDU) will be stored in the memory. Default correction values after power up are zero.

11.5.4 Outdoor Fan Speed Control

11.5.4.1 General Rules

- OFAN operates between *OFMinRPM* to *OFMaxRPM*.
- The OFAN speed is consecutive and related to the high pressure of the system.
- The fan speed is also related to compressor speed, outdoor temperature and to protections.

11.5.4.2 Behavior when there is a failure in OFAN

Whenever OFAN fault occurs the compressor will be stopped immediately, except during deicing protection, then the OFAN will be enabled to be started for maximum 5 times. This rule is enabled each time the ODU switches to heat/cool modes.

11.5.4.3 Protection Behavior

- When in total IDU protection level is different than normal, the OFAN will reduce *OFSpdReducePrnC* and *OFSpdReducePrnH* RPM for cool and heat respectively.
- In cool mode the OFAN will operate according to CTT or HST protection level:

Protection level	Action
SR, D1 or D2	OFAN will add 100 RPM to the target speed
Stop-Compressor	continue to operate for maximum 2 minutes at it last speed or until normal level is achieved.

11.5.4.4 OFAN Force On condition

If HST is higher than 70°C or defined as “HST bad”, OFAN will remain ON at the last operating speed for maximum 2 minutes after COMP is OFF.

11.5.4.5 Night mode

Upon receiving night mode, the OFAN will be limited to max *NightRPM* speed only in Cool. It will be back to its normal operation when receiving the mode is cleared.

11.5.5 RV State Setting

During heat mode (except during Deicing) RV is ON.
 During cool/SB mode RV is OFF.
 RV status will be changed only if COMP is OFF for 3 minutes or more.

11.5.6 Base Heater Setting

The base heater will be working only when RV is “ON” according to the following graph:

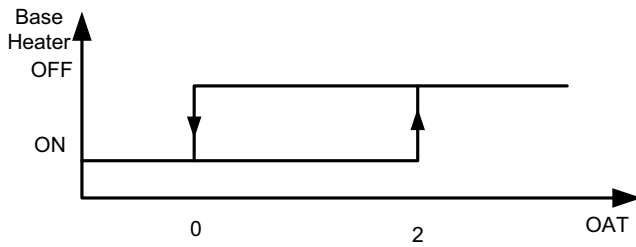

When OAT is faulty the base heater will be “ON” continuously in HEAT mode.

11.5.7 Thermodynamic Protections

11.5.7.1 Protection level definition

Five protection levels are defined:

Normal – No protection status is ON.

Stop-Rise (SR) – System is in protection, first level

D1 - System is in protection, second level

D2 - System is in protection third level

Stop-Compressor (SC) – System is in protection fourth level

11.5.7.2 IDU Protection Level

The ODU receives the protection levels from each one of the IDU. The protection levels are weighted according to the following table:

Protection Level	Weight
Normal	0
Stop-Rise	1
D1	2
D2	3
Stop-Compressor	0

The IDU protection level calculated weight according to the following average:

$$IDU \text{ protection level} = \text{round up} \left(\frac{\sum_{i=1}^n IDU_i \text{ protection weight}}{n} \right)$$

Where,

n- The number of active IDU units.

11.5.7.3 IDU Protections

11.5.7.3.1 Indoor Coil Defrost Protection

ICT	ICT Trend				
	Fast Increasing	Increasing	No change	Decreasing	Fast Decreasing
ICT < -2	SC	SC	SC	SC	SC
-2 ≤ ICT < 0	D1	D1	D2	D2	D2
0 ≤ ICT < 2	SR	SR	D1	D2	D2
2 ≤ ICT < 4	SR	SR	SR	D1	D2
4 ≤ ICT < 6	Norm	Norm	SR	SR	D1
6 ≤ ICT < 8	Norm	Norm	Norm	SR	SR
8 ≤ ICT	Normal				

11.5.7.3.2 Indoor Coil over Heating Protection

ICT	ICT Trend				
	Fast Decreasing	Decreasing	No Change	Increasing	Fast Increasing
ICT > 55	SC	SC	SC	SC	SC
53 < ICT ≤ 55	D1	D1	D2	D2	D2
49 < ICT ≤ 53	SR	SR	D1	D2	D2
47 < ICT ≤ 49	SR	SR	SR	D1	D2
45 < ICT ≤ 47	Norm	Norm	SR	SR	D1
43 < ICT ≤ 45	Norm	Norm	Norm	SR	SR
ICT ≤ 43	Normal				

11.5.7.4 ODU Protections

There are 3 ODU protections:

- Compressor overheating
- Heat sink overheating
- System over power

Operation logic of all protections is the same. The controlled input (CTT, HST, or PWR) is controlled by changing the protection level using the fuzzy logic algorithm according the input level and the change rate.

There are two sets of POWER values, the selection of the values are set according to the state of the Power-Shed dry contact input.

Power-Shed input open → Power1

Power-Shed input sort → Power2

The following table summarizes the basic levels of each protection.

Protection level	Compressor Overheat - cool (CTT)	Compressor Overheat - heat (CTT)	Heat Sink (HST)	Power1	Power2
Stop compressor	105	105	83	3600	2900
Down 2	100	100	81	3400	2750
Down 1	98	95	77	3200	2600
Stop rise	95	85	75	3100	2450
Normal	90	80	73	3050	2300

11.5.7.5 Total Protection Level Definition

The total protection level is defined by the higher level of protection received.

11.5.8 Deicing

11.5.8.1 Deicing Starting Conditions

Deicing operation will start when either one of the following conditions exist:

Case 1: OCT < OAT – DST AND TLD > DI

Case 2: OCT < OAT – 12 AND TLD > 30 minutes.

Case 3: OCT is Invalid AND TLD > DI

Case 4: Unit is just switched to STBY AND OCT < OAT – DST

Case 5: NLOAD = 0 AND OCT < OAT - DST

Case 6: OAT is invalid AND OCT < DST AND TLD > DI AND Compressor ON Time > CTMR minutes

OCT – Outdoor Coil Temperature

OAT – Outdoor Air Temperature
 TLD – Time from Last Deicing
 DI – Deicing Interval (Time Interval between Two Deicing)
 DST – Deicing static threshold (Temperature)

Deicing interval time when compressor is first started in heat mode, is 10 minutes if OCT < -2, and is 40 minutes in other cases.
 Deicing interval time is changed (increased/ decreased in 10 minutes steps) as a function of deicing time. If deicing time is shorter than former deicing time, the deicing interval time will be increased. If deicing time is longer than former deicing time, the deicing interval time will be decreased.

11.5.8.2 Deicing Protection Procedure

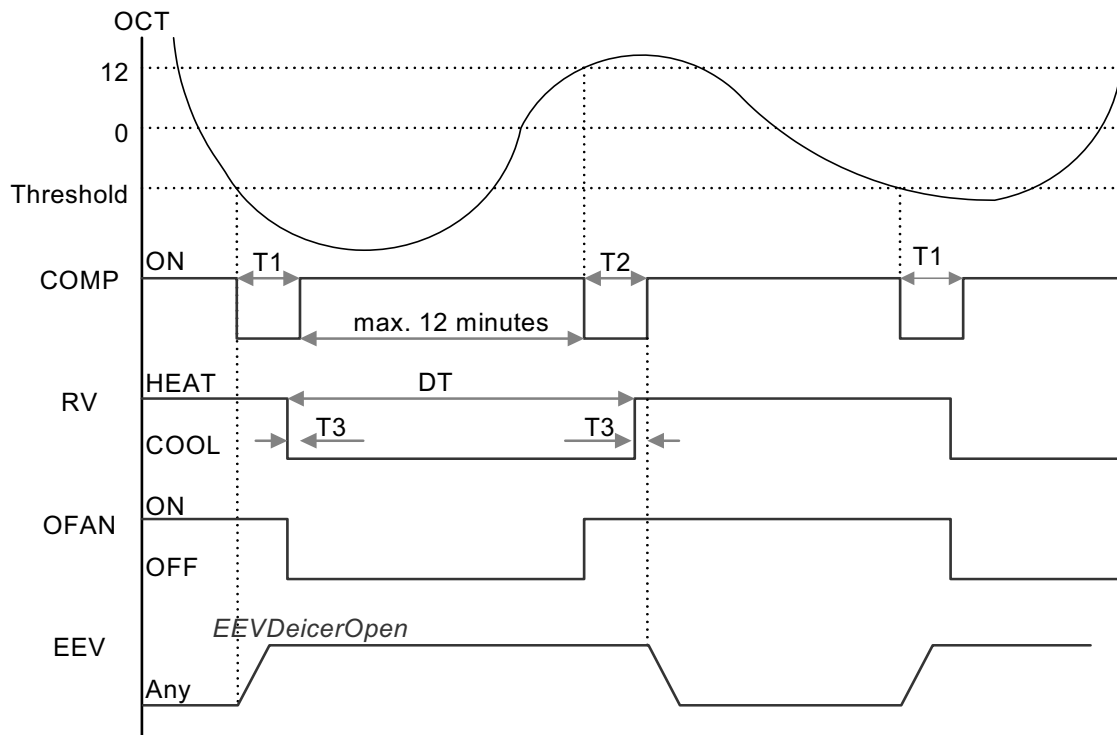

T1 = T2 = 36 seconds, T3 = 6 seconds

11.5.9 Condensate Water over Flow Protection



Each of the pins P1, P2, P3 can have two options:
 1 – When it is shorted with P4
 0 – When it is not shorted to P4

11.5.9.1 3 Levels Logic (used in floor/ceiling models)

P2	P3	Level
0	0	L0
1	0	L1
1	1	L2&3

0	1	L4
---	---	----

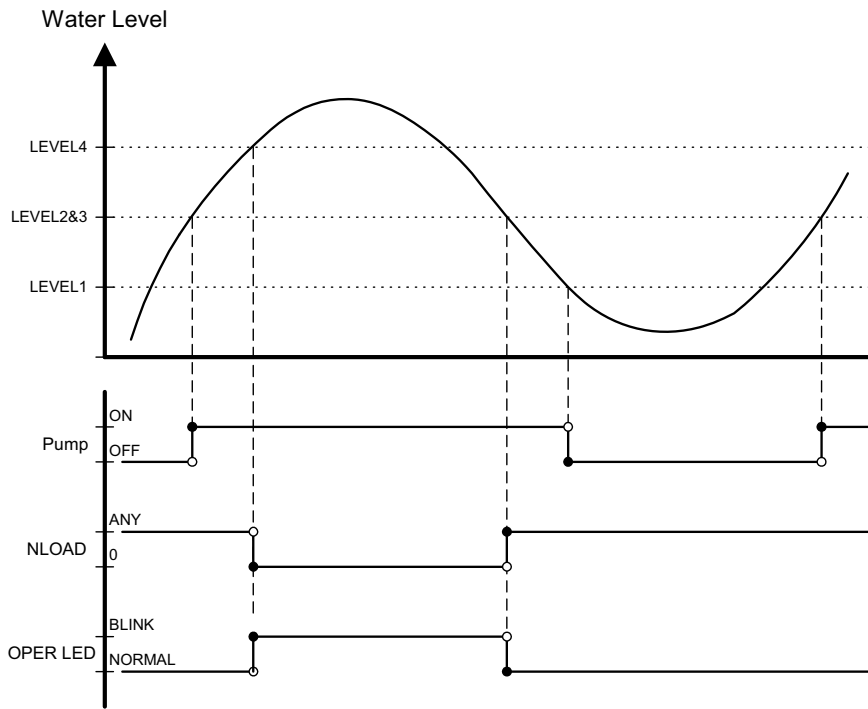

11.5.9.2 1 Level Logic (used in all models except for floor/ceiling models)

P2	P3	Level
Don't care	1	Normal
Don't care	0	Overflow

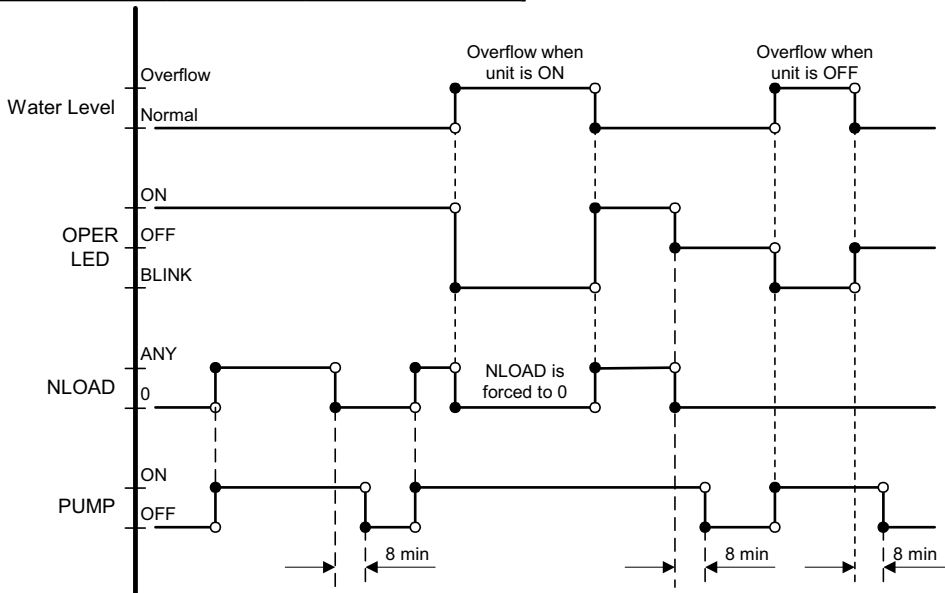

11.6 Installation Test Mode

See "A APPENDIX".

11.7 Technician Test Mode

This test is aimed for the technicians to check the system under a preset compressor and outdoor fan values while the expansion valves will function according to the normal running mode.

11.7.1 Entering technician mode

- This mode is entered through the outdoor unit using the HMI (refer to user interface section).
- It can be selected either for cool or heat.
- Technician test is not possible to enter during deicer.

11.7.2 Technician mode procedure

- All the connected indoor units will enter technician test at high indoor fan speed.
- The outdoor unit will be working normally (according to the run mode control logic) except the following changes:
 - The dry contacts inputs will be ignored.
 - Protections will be operative for stop compressor (not to be implemented in the current version).
 - The compressor and the outdoor fan will be working in target preset values according to the following table:

Technician Test			
Unit	Compressor Speed		OFAN speed
	Cool	Heat	
Trio	60	75	High speed
Quattro	60	75	High speed

11.7.3 Exiting technician mode

Technician mode will be exited either when:

- Escaping by the HMI (exiting the ttC or ttH menus)
- 60 minutes are passed from entering

11.8 User Interface

11.8.1 User interface description

- The user interface uses three 7 segments, and 4 keys.
- Keys, The 4 keys are:
 - Scroll - used to scroll between options (up and down)
 - Select - use to select an option
 - Escape - Will go up one level in the menu
- The user interface concept is Tree menus.
- Active selection or status will be indicated by a dot at the right side of the third digit.

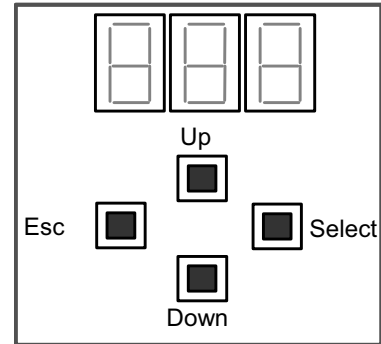

11.8.2 Keys functionality

- Scrolling will be done whenever the button is pressed.
- When scrolling alpha values, if the scroll button is held in, the selection will change at the rate of one step per second.
- When changing/scrolling numeric value, if the scroll button is held in, the selection will change at the rate of one step per second. After 2 seconds, if the button continues to be held in, the rate of change will increase to 10 steps per second.

The display will not roll over during selection (for example stop/Ode/Dia/Stp/Par/stop)

11.8.3 Menus

11.8.3.1 Main Menu

Mode (Cl/Ht/Sb)	□□□	HE□	SB□
Technician Test (tt)	□EE		
		Technician Test Cool (ttC)	EE□
		Technician Test Cool (ttH)	EEH
Installation Test (it)	□□E		
Diagnostics (dia)	□□A		
		Outdoor Unit (oxx)	□□A
		Indoor Unit A (axx)	A□A
		Indoor Unit B (bxx)	B□A
		Indoor Unit C (cxx)	C□A
		Indoor Unit D (dxx)	D□A
Set Up (Stp)	SE□		
		First IDU Wins (idu)	□A□
		IDU A is master (a-p)	A-□
		IDU B is master (b-p)	B-□
		IDU C is master (c-p)	C-□
		IDU D is master (d-p)	D-□
		'Forced mode' input (Frc)	F-□
Parameters changing (Par)	PE□		
		Change Parameters (CHG)	□HA
		Restore Factory Parameters (RST)	RS□
Status (Stt)	SEE		
		IDU (IdU)	□A□
		ODU (OdU)	□A□
		Timer (Tr)	EE□

Notes:

- The default presentation will be the mode of the unit (Cl/Ht/Sb).
- In diagnostics menu, xx means failure code. Only the last active (operative) failure code will be shown, if there is no active failure a “-“sign will be shown (the faults Numbers are the one shown in the single split table).
- The Parameters Changing and Status menus (Technician menus) will be enabled to be presented and navigated, only by pressing select + escape together for more than 5 seconds under the main menu.
- Exiting both 'Parameters Changing' and 'Status' menus and their sub-menus back to the main menu is done only by either pressing escape for more than 5 seconds or after continuous 10 minutes out of any press.

- Technician Test mode is exited after 60 minutes from entry.
- All the menus, except technician menus- Parameter changing, Status, Technician Test and their sub menus, are automatically exited to the main menu after 1 continuous minute out of any press.
- When Technician test cool or heat menu is selected, it will blink constantly until this menu is escaped.
- Pressing select and escape buttons together when in RST for more than 5 seconds will restore only the parameters of the factory settings. Acknowledge for restored parameters will be indicated by blinking RST for 3 seconds.

11.8.3.2 Parameter Change (Sub Menu)



- The parameters names will be indicated by the sequence 001, 002,...,999.
- When a parameter is selected, the parameter's stored value is presented-aligned to the right.
- Scrolling changes the presented value, incrementing or decrementing, but does not store the value.
- Selecting a value, by pressing the selection key for 3 seconds, stores an updated value.
- A dot at the right side of the stored value is presented to indicate the current stored value.

11.8.3.3 Status (Sub Menu)

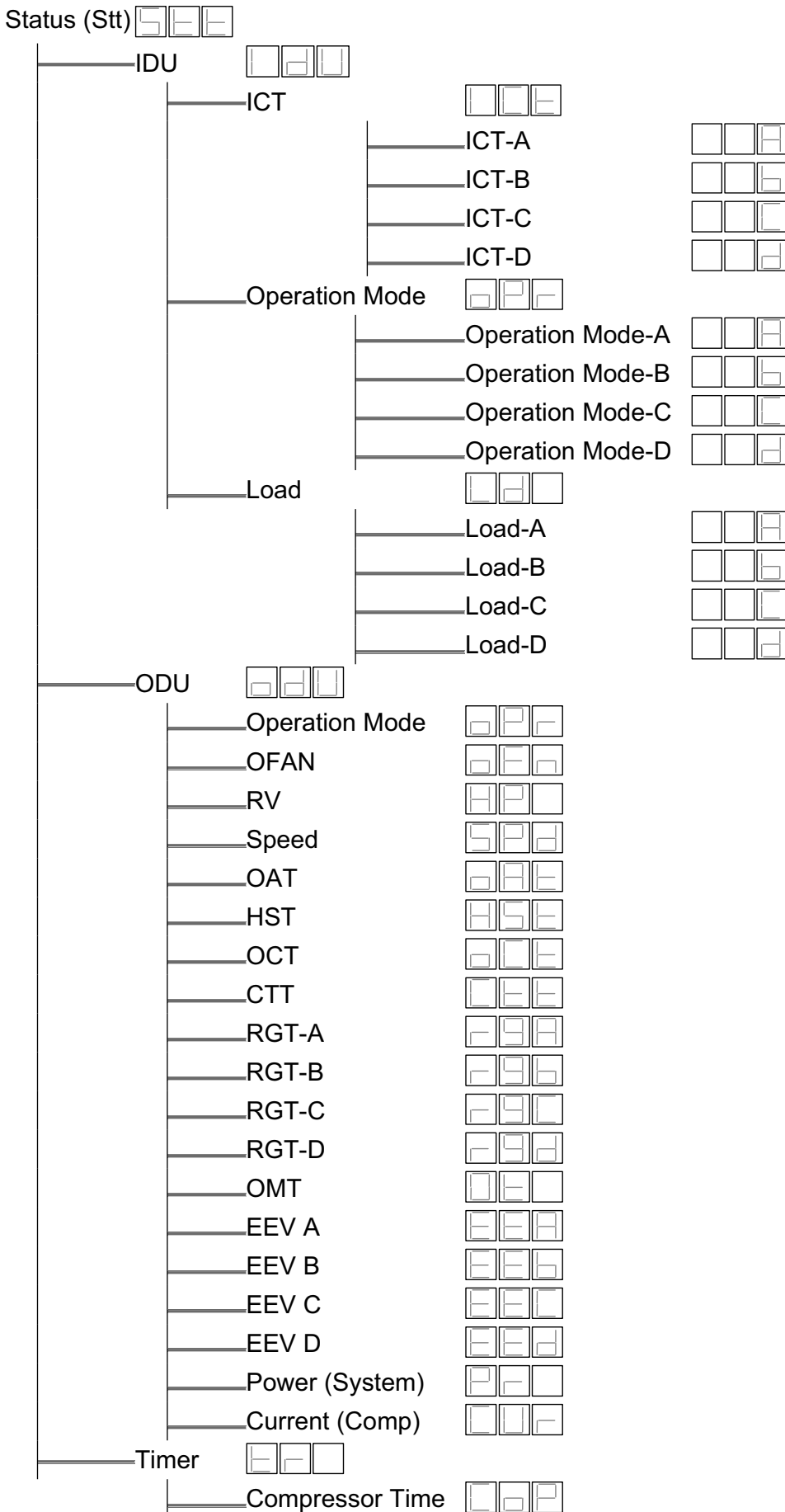

Notes:

- For the temperature display, when a thermistor is shorted or disconnected it shows FLT (FLt), when it is disabled it shows DIS (dis).
- It's possible to present a number between 999 and 99,999 by alternating between two numbers (each number is presented for 1 second). The two numbers format is "xx, yyy".
- Pressing select + escape together for 5 seconds will reset the counter to 0.
- The compressor time is measured in hours.

11.9 Jumper settings

11.9.1 Jumper definitions

0 = open (disconnected)

1 = closed (shorted)

11.9.2 OFAN Jumpers

OFAN use parameters	J2	J1
Panasonic- EHD80	0	0
Nidec SIC-71FW-F170-1	0	1
Shinano	1	0
EEPROM	1	1

11.9.3 Compressor Jumpers

Compressor use parameters	J3
TNB220FLBM (ROM)	0
EEPROM	1

11.10 System Parameters

11.10.1 General parameters

Parameter	Default Value
<i>ODUCodeLimit</i>	6

11.10.2 Protection Parameters

Deicer Parameters	
Parameter	Default
<i>DST</i>	8
<i>DSTF</i>	12
<i>DIF (min)</i>	30
<i>CTMR (min)</i>	15
<i>TimeD (min)</i>	1
<i>DIT (min)</i>	10
<i>DTmin (min)</i>	3
<i>Dlmin (min)</i>	30
<i>Dlmax (min)</i>	120
<i>DeicSPChRV</i>	0
<i>EEVDeicerOpen</i>	180
<i>DEICT1 (sec)</i>	50
<i>DEICT2 (sec)</i>	36
<i>DEICT3 (sec)</i>	6
<i>OptimDeicSP</i>	90

11.10.3 Compressor Parameters

Compressor Parameters	Value
MinOFFTime	3
MinOnTime	3
MaxSpeedC	75
MaxSpeedH	95
Step1RPS	40
Step2RPS	60
Step3RPS	75

11.10.4 OFAN parameters

EEV Parameters	Value
OFMinRPM	150
OFMaxRPM	1000
NightRPM	650
OFMinTimeReduce (Sec)	60

11.10.5 Indoor Units SW Parameters

11.10.5.1 General Parameters for All Models:

Parameters defining the indoor fan speed as a function of Indoor Coil temperature in heat mode (ICT):

11.10.5.1.1 Parameters for defrost protection:

ICTST Speed	ICT to stop indoor fan	25
ICTVLSpeed	ICT to go down to very low speed	28
ICTLSpeed	ICT to start in very low speed	30
ICTHSpeed	ICT to start in increase speed from very low	32
ICTTSpeed	ICT to enable Turbo fan speed	40
ICTDef1	ICT to go back to normal	8
ICTDef2	ICT to 'stop rise' when ICT decrease	6
ICTDef3	ICT to 'stop rise' when ICT is stable	4
ICTDef4	ICT to 'Hz Down' when ICT decrease	2
ICTDef5	ICT to 'Hz Down' when ICT is stable	0
ICTDef6	ICT to stop compressor	-2

11.10.5.1.2 Parameters for indoor coil over heating protection:

ICTOH1	ICT to go back to normal	45
ICTOH2	ICT to 'stop rise' when ICT increase	48
ICTOH3	ICT to 'stop rise' when ICT is stable	52
ICTOH4	ICT to 'Hz Down' when ICT increase	55
ICTOH5	ICT to 'Hz Down' when ICT is stable	60
ICTOH6	ICT to stop compressor	62

11.10.5.2 Model Depended Parameters:

Parameter name	Wall Mounted Models			Floor/Ceiling Models			Cassette Models			Ducted Models	
	25	35	50	25	35	50	25	35	50	35	50
NLOAD limits as a function of selected indoor fan speed											
MaxNLOADIF1C	40	40	45	40	40	40	40	40	40	N/A	N/A
MaxNLOADIF2C	53	53	62	53	53	60	53	56	60	N/A	N/A
MaxNLOADIF3C	120	120	120	120	120	90	120	90	90	N/A	N/A
MaxNLOADIF4C	127	127	127	127	127	90	127	90	90	N/A	N/A
MaxNLOADIF5C	127	127	127	127	127	90	127	90	90	N/A	N/A
Indoor Fan speeds											
IFVLOWC	700	700	700	Fix RPM Motor							
IFLOWC	800	800	900								
IFMEDC	900	950	1050								
IFHIGHC	1050	1100	1200								
IFTURBOC	1150	1200	1250								
IFVLOWH	700	700	700								
IFLOWH	800	850	900								
IFMEDH	950	1000	1100								
IFHIGHH	1100	1150	1250								
IFTURBOH	1200	1250	1300								

12. TROUBLESHOOTING

WARNING!!!

When Power Up – the whole outdoor unit controller, including the wiring, is under HIGH VOLTAGE!!!

Never open the Outdoor unit before turning off the Power!!!

When turned off, the system is still charged (400V)!!!

It takes about 1 Min. to discharge the system.

Touching the controller before discharging may cause an electrical shock!!!

For safe handling of the controller please refer to section 12.5 below.

12.1 General System Failures and Corrective Actions

No	SYMPTOM	PROBABLE CAUSE	CORRECTIVE ACTION
1.	Indoor unit power supply indicator (Red LED) does not light up.	No power supply	Check power supply. If OK, check display and display wiring. if OK, replace controller
2.	Indoor unit does not respond to remote control message	Remote control message not reached the indoor unit	Check remote control batteries, if OK, check display and display wiring, if OK, replace display PCB. If still not OK replace controller
3.	Indoor unit responds to remote control message but Operate indicator (Green LED) does not light up	Problem with display PCB	Replace display PCB. If still not OK replace controller
4.	Indoor fan does not start (louvers are opened and Green LED is ON)	Unit in heat mode and coil is still not warm	Change to cool mode
		Outdoor unit is in opposite mode	Change operation mode
		Problem with controller or capacitor	Change to high speed and Check power supply to motor is higher than 130VAC (for triack controlled motor) or higher than 220VAC for fixed speed motors, if OK replace capacitor, if not OK replace controller
5.	Indoor fan works when unit is OFF, and indoor fan speed is not changed by remote control command.	Controller problem	Replace controller
6.	Water leakage from indoor unit	Indoor unit drainage tube is blocked	Check and open drainage tube
7.	One indoor unit or more are operating in cool mode with no capacity, and the other units have water leaks/freezing problems	The communication wires of the indoor units are switched	Check and correct the communication wires connection
8.	One indoor or more are operating in heat mode with a limited capacity, and the coil on the other units are very hot.		
9.	Outdoor unit display board and leds are off	No power supply	Check the connections and the wiring on the main terminal - Repair if needed.
		PFC Chock coil	Check the PFC Chock coil (12.4.3)
		Burnt fuse	Check 20A fuse on the Filter (12.4.2)
10.	Compressor operates but one or more units generates no capacity	EEV problem	Check EEV (12.4.7)
		Refrigerant leakage	Check refrigeration system (12.2)

No	SYMPTOM	PROBABLE CAUSE	CORRECTIVE ACTION
		Indoor coil block	Clean filters and/or remove block
		Outdoor coil block	Remove block and/or avoid air by-pass
11.	Compressor is over heated and unit does not generate capacity	EEV problem	Check EEV (12.4.7)
		Refrigerant leakage	Check refrigeration system (12.2)
		Indoor coil block	Clean filters and/or remove block
		Outdoor coil block	Remove block and/or avoid air by-pass
12.	Compressor stops during operation	Electronic control	Check diagnostics (see 12.3 below)
		Refrigerant leakage	Check refrigeration system (12.2)
13.	Not all units are operating	Communication problems	Check diagnostics (see 12.3 below)
14.	Compressor does not start	Electronics control problem or protection	
15.	Unit works in wrong mode (cool instead of heat or heat instead of cool)	Electronics or RV problem	Check RV (12.4.6)
16.	All components are operating properly but no cooling or no heating	Refrigerant leak	Check refrigeration system (12.2)
17.	Compressor motor is generating noise and no suction occurs	Phase order to compressor is wrong	Check compressor phase order
18.	Freezing of outdoor unit in heat mode and outdoor unit base is blocked with ice		Connect base heater
19.	The unit stop suddenly during operation	EMC interference to the A/C unit	Check for EMC problems (12.4.10.1)
20.	Indoor unit(s) Indicator(s) leds may flicker		
21.	Other home appliances operation is faulty such as noise appears in the television picture, or the picture is distorted or static occurs in the radio sound	EMC interference by the A/C unit	Check for EMC problems (12.4.10.2)
22.	All others	Specific problems of indoor or outdoor units	Check diagnostics (see 12.3 below)

12.2 Checking the refrigeration system

Checking system pressures and other thermodynamic measures should be done when system is in technician Mode where the system operates as in fixed settings. The performance curves given in this manual are given for unit performance in Technician mode when high indoor fan speed is selected.

For entering technician mode check 11.7.

12.3 Diagnostics

12.3.1 Outdoor unit diagnostics and corrective actions

No	Fault Name	Fault Description	Corrective Action
1	OCT bad	Thermistor not connected or damaged	Check Thermistor (12.4.8)
2	CTT bad		
3	HST bad		
4	OAT bad		
5	OMT bad		
6	RGT bad		
7	OFAN/Compressor Feedback Loss	OFAN halls or wires bad. Compressor wire cable bad or IPM bad or compressor bad	Check OFAN motor (12.4.4) and compressor (12.4.5)
8	OFAN - IPM fault	Over current / Over temperature of OFAN IPM	Check no obstruction to controller air opening Check OFAN motor (12.4.4) Check motor type matches motor jumpers in controller
9	OFAN Lock	Fan does not rotate	Check OFAN motor (12.4.4)

No	Fault Name	Fault Description	Corrective Action
10	OFAN- Vospd exceeded	Exceeds speed high limit	Check motor type matches motor jumpers in controller Make necessary arrangements in unit installation location to avoid back wind Avoid EMC problems (12.4.10.1)
11	Compressor- IPM Fault	Over current / Over temperature of compressor IPM	Check no obstruction to controller air opening Check Compressor (12.4.5)
12	Compressor Lock	Compressor does not rotate	Check Compressor (12.4.5)
13	Compressor- Vospd exceeded	Exceeds speed limit	Try again and replace controller if still have the problem
14	Compressor- Foldback	High pressure / Current reduces compressor speed	Check Compressor (12.4.5)
15	DC under voltage	DC voltage is lower than limit	Replace controller
16	DC over voltage	DC voltage exceeds its high limit	Check if input voltage higher than limit (270VAC), if not and the problem persists, replace controller. If voltage is high, shut off the power and recommend the customer to fix the power supply
17	AC under voltage	AC input voltage is lower than limit	Check if input voltage lower than limit (170VAC), if not and the problem persists, replace controller. If voltage is low, recommend the customer to fix the power supply
18	No communication A	No signals in line A	Check communication (12.4.9)
19	No communication B	No signals in line B	
20	No communication C	No signals in line C	
21	No communication D	No signals in line D	
22	Compressor- Illegal Speed	Exceeds speed low limit	See # 13
23	System Configuration Changed	Communication lines changed from last operation	No problem just an announcement
24	System Configuration Problem	Miss-match between the IDUs connected to port A,B,C or D, or the total capacity code of IDUs is higher than the ODU maximum capacity code	Change configuration if needed.
25	Heat sink Over Heating Fault/Protection	Compressor stopped due to heatsink protection	Check that the airflow around the ODU is free and the fan is running free. Check fan motor (12.4.4)
26	Deicing Protection	During deicing procedure	No action required
27	Compressor Over Heating Protection	Compressor stopped due to over heat protection	Check if gas is missing in the system
28	System over power Protection	Compressor stopped due to over power protection	No action required
29	Bad EEPROM	EEPROM not operating	Power reset. (Replace Controller just in case you need EEPROM).
30	Not Configured	Cannot start the control	Power reset. Replace Controller if didn't help

12.3.2 Fault Code for Indoor unit

Pressing Mode button for long will activate diagnostic mode by the acknowledgment of 3 short beeps and lighting of COOL and HEAT LED's.

When Indoor diagnostics is displayed, all four LED's (STBY, Operate, Filter, TMR) are on.

Entering diagnostics in STBY mode allows only viewing of status (fault-display).

In diagnostic mode, system problems / information will be indicated by blinking of Heat & Cool LED's.

The coding method will be as follows:

Heat led will blink 5 times in 5 seconds, and then will be shut off for the next 5 seconds. Cool

Led will blink during the same 5 seconds according to the following table:

No	Fault Name	5	4	3	2	1
1	RT-1 is disconnected	0	0	0	0	1
2	RT-1 is shorted	0	0	0	1	0
3	RT-2 is disconnected	0	0	0	1	1
4	RT-2 is shorted	0	0	1	0	0
...	Reserved	0	0	1	0	1
7	Communication mismatch	0	0	1	1	1
8	No Communication	0	1	0	0	0
9	No Encoder	0	1	0	0	1
10	Reserved	0	1	0	1	0
11	Outdoor Unit Fault	0	1	0	1	1
...	Reserved					
17	Defrost protection	1	0	0	0	1
18	Deicing Protection	1	0	0	1	0
19	Outdoor Unit Protection	1	0	0	1	1
20	Indoor Coil HP Protection	1	0	1	0	0
21	Overflow Protection	1	0	1	0	1
...	Reserved					
24	EEPROM Not Updated	1	1	0	0	0
25	Bad EEPROM	1	1	0	0	1
26	Bad Communication	1	1	0	1	0
27	Using EEPROM data	1	1	0	1	1
28	Model A	1	1	1	0	0
29	Model B	1	1	1	0	1
30	Model C	1	1	1	1	0
31	Model D	1	1	1	1	1

1 - ON, 0 - OFF

Only one code is shown. Order of priority is lower to the higher number. Diagnostics is continuously ON as long power is on.

12.3.3 Indoor unit diagnostics and corrective actions

No.	Fault	Probable Cause	Corrective Action
1-4	Sensor failures	Sensors not connected or damaged	Check sensor connections or replace sensor
7	Communication mismatch	Indoor and Outdoor controllers are with different versions	Replace Indoor controller
8	No Communication	Communication or grounding wiring is not good	Check Indoor to Outdoor wiring and grounding
9	No Encoder	Indoor electronics or motor	Check motor wiring, if ok, replace motor, if still not ok, replace Indoor controller.
11	Outdoor Unit Fault	Outdoor controller problem	Switch to Outdoor diagnostics.
17-21	Protections	Indication	No action
24	EEPROM Not Updated	System is using ROM parameters and not EEPROM parameters	No action, unless special parameters are required for unit operation.
25	Bad EEPROM		No action, unless special parameters are required for unit operation.
26	Bad Communication	Communication quality is low reliability	Check Indoor to Outdoor wiring and grounding
27	Using EEPROM data	No problem	
28-31	IDU model	Indication : DCI-25,35,50,60	

12.4 Procedures for checking Main Parts

12.4.1 Checking Mains Voltage

Confirm that the Mains voltage is between 198 and 264 VAC. If Mains voltage is out of this range, abnormal operation of the system is expected. If in range check the Power (Circuit) Breaker and look for broken or loosed cable lugs or wiring mistake(s).

12.4.2 Checking Main fuse

Check 20A fuse on the Filter Board - If burnt – check the compressor, fan or any other peripheral that can cause a short. In case of a problematic peripheral - replace it.
In case no problematic peripheral, check the resistance on the DC bank (B+ & B- on the Power board), if it is less than 30Ω, replace the controller. Otherwise replace the burnt fuse.
In case of frequent burning fuse, replace the controller.

12.4.3 Checking PFC Chock coil

Check PFC chock connection – repair if needed.
Dis-connect the chock from the controller wire extensions, check if the 2 wires of the chock are shorted. If shorted (OK) check between each wire and the metal box. If shorted replace chock, if not (OK), open the controller top cover and check if the wire extensions are connected well and if shorted. If not shorted, replace wires, if shorted (OK) than might be a controller problem – replace controller.

12.4.4 Checking the Outdoor Fan Motor

Check FAN-Power and FAN-Halls connections - Repair if needed.
Rotate the fan slowly by hand. If the fan does not rotate easily, check whether something is obstructing the fan, or if the fan itself is coming into contact with the outer case, preventing it from rotating. Correct if necessary - otherwise, the fan motor bearings have seized. Replace the motor.
If the fan rotates easily, use a current probe (“Clamp”) to assure AC current on each phase and it is less than 1A.
In case there is no current, check the resistance between the three poles. Assure the three coil resistances are almost the same.

The normal value should be between 10Ω to 20Ω.

Change to Stand-by or Power OFF and re-start - If the fault is still active - replace controller.

12.4.5 Checking the Compressor

Check Compressor connections - Repair if needed.

Use a current probe ("Clamp") to assure that there is an AC current on each phase – no more than 15A.

In case there is no current, check the resistance between the three poles. Assure the three coil resistances are almost the same (between 0.8Ω to 1.5Ω).

Change to Stand-by or Power OFF and re-start - If the fault is still "Active" - replace controller.

12.4.6 Checking the Reverse Valve (RV)

The RV has two parts, Solenoid and valve.

Solenoid - Running in heating mode, check the voltage between two pins of reverse valve connector, normal voltage is 230VAC. if no power supply to RV, Check RV operation with direct 230VAC power supply, if OK, replace outdoor controller.

Valve - if RV solenoid is OK (as above) but still no heating operation while compressor is On, replace the valve.

12.4.7 Checking the electrical expansion valve (EEV)

The EEV has two parts, drive and valve.

When Outdoor unit is powered on, EEV shall run and have click and vibration.

For assuring the problem is of the EEV parts, perform the installation test (see 11.6) and if fails and no other indications in the diagnostics, than the problem is with the EEV (one or more).

Drive - a step motor; ringed on the valve. Check the drive voltage, should be 12VDC.

Valve – if drive is OK (as above) but still the indoor unit perform no conditioning replace the valve (no need to take out the refrigerant, just pump down and shut off the main valves).

12.4.8 Checking the thermistors

Check Thermistor connections and wiring - Repair if needed.

Check Thermistor resistance – between 0°C and 40°C should be between 35KΩ and 5KΩ.

12.4.9 Checking the communication

Change to Stand-by or Power OFF and re-start - If the fault is still "Active" check Indoor to Outdoor Communication wiring and grounding connections (should be less than 2.0Ω) - Repair if needed.

If IDU failure – replace IDU controller that does not respond.

If ODU failure – replace ODU.

12.4.10 Checking for electromagnetic interference (EMC problems)

12.4.10.1 EMC troubles to the A/C unit

Locations most susceptible to noise :

1. Locations near broadcast stations where there are strong electromagnetic waves.
2. Locations near amateur radio (short wave) stations.
3. Locations near electronic sewing machines and arc-welding machines.

Trouble :

Either of the following trouble may occur:

1. The unit may stop suddenly during operation.
2. Indicator lamps may flicker

Correction :

The fundamental concept is to make the system less susceptible to noise

(insulate for noise or distance from the noise source):

1. Use shielded wires.
2. Move unit away from the noise source.

12.4.10.2 EMC troubles to near by home appliances

Locations most susceptible to noise :

1. A television or radio is located near the A/C and A/C wiring.
2. The antenna cable for a television or radio is located close to the A/C and A/C wiring.
3. Locations where television and radio signals are weak.

Trouble :

1. Noise appears in the television picture, or the picture is distorted.
2. Static occurs in the radio sound.

Correction

1. Select a separate power source.
2. Keep the A/C and A/C wiring at least 1 meter away from wireless devices and antenna cables.
3. Change the wireless device's antenna to a high sensitivity antenna.
4. Change the antenna cable to a BS coaxial cable.
5. Use a noise filter (for the wireless device).
6. Use a signal booster.

12.5 Precaution, Advise and Notice Items

12.5.1 High voltage in Outdoor unit controller

Whole controller, including the wires, connected to the Outdoor unit controller may have the potential hazard voltage when power is on. Touching the Outdoor unit controller may cause an electrical shock.

Advise: Don't touch the naked lead wire and don't insert finger, conductor or anything else into the controller when power is on.

12.5.2 Charged Capacitors

Three large-capacity electrolytic capacitors are used in the Outdoor unit controller. Therefore, charging voltage (380VDC) remains after power down. Discharging takes about one minute after turned off. Touching the Outdoor unit controller before discharging may cause an electrical shock. When open the Outdoor unit controller cover, don't touch the soldering pin by hand or by any conductive material.

Advise:

- Open the Outdoor unit controller cover only after one minute from power off.
- Measure the electrolytic capacitors voltage before farther checking controller.

Additional advises

- When disassemble the controller or the front panel, turn off the power supply.
- When connecting or disconnecting the connectors on the PCB, hold the whole housing, don't pull the wire.
- There are sharp fringes and sting on shell. Use gloves when disassemble the A/C units.

13. EXPLODED VIEWS AND SPARE PARTS LISTS

13.1 Outdoor Unit: Multi Trio-72 DCI

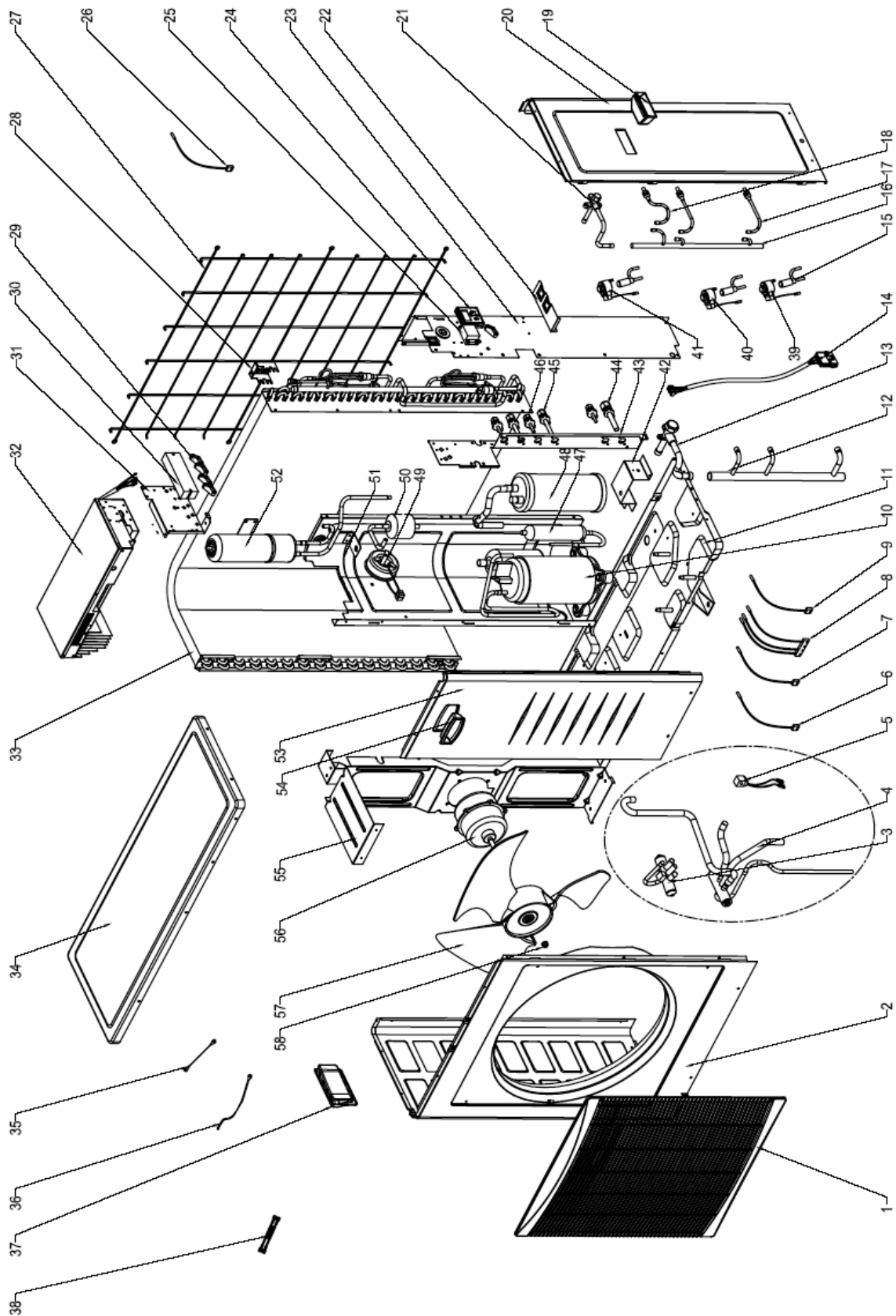

13.2 Outdoor Unit: Multi Trio-72 DCI

No.	P/N	Description	Quantity
1	4522604	Outlet Grid	1
2	4523652	Painted Left Cabinet Assy.	1
3	4526522	4-way Vavle R410a	1
4	452803600	4-way Valve System Assy.	1
5	452956700	4-way Valve Coil	1
6	452966200	Compressor Top Thermistor(CTT)	1
7	452677601	Outdoor Coil Thermistor(OCT)	1
8	467400000	Return Gas Thermistor(RGT)	1
9	452956500	Suction Thermistor(SUCT)	1
10	453174100	Compressor Assy. TNB220FLBM	1
11	452809900	Base Plate Painting Assy.	1
12	452962800	Manifold Assy.	1
13	452783000	Low Pressure Stop Valve 5/8" R410a	1
14	452956600	Compressor Cable	1
15	4526827	Electronical Expansion Valve CAM-BD15 FKS-1	3
16	452962700	Distributing Pipe Assy.	1
17	452805100	Connect Pipe 2/Electronic Expansion Valve to High Pressure Stop Valve	2
18	452803000	Connect Pipe 1/Electronic Expansion Valve to High Pressure Stop Valve	1
19	4517772	Little Handle	1
20	452957700	Painted Side Plate Assy.	1
21	452783100	High Pressure Stop Vavle 3/8" R410a	1
22	452956200	Painted Stop Plate Assy.	1
23	452957600	Painted Right-back Plate Assy.	1
24	467300005	Display Board Assy.	1
25	453031800	3 Poles Terminal Block	1
26	4526774	Outdoor Air Thermistor(OAT)	1
27	453175500	Guard Net Painting Assy.	1
28	453083800	Support/OAT	1
29	204107	Cable Clip Nylon	5
30	453031700	10 Poles Terminal Block	1
31	453256700	Support Painting Assy./Electrical Box	1
32	452956100	DCI Outdoor Controller 3.1kW	1
33	452802500	Condensor System Assy.	1
34	4523657	Painted Top Cover Assy.	1
35	453256800	Ground Wire 1	1
36	453256900	Ground Wire 2	1
37	4522600	Left Handle	1
38	4526226	Power Lead Wire	1
39	452682803	EEV Coil(Green Connector 800mm)	1
40	452682800	EEV Coil(Red Connector 530mm)	1
41	452682802	EEV Coil(White Connector 530mm)	1
42	453256100	Support Painting Assy./Gas-Liquid Sperator	1
43	464860000	Valve Support Painting Assy.	1
44	452783500	Brass Connector With Flange 1/2"	1
45	452783501	Brass Connector With Flange 3/8"	2
46	452783502	Brass Connector With Flange 1/4"	3
47	452783600	Oil Sperator Assy.	1
48	452783200	Gas-Liquid Sperator	1
49	453256000	Chock Assy.	1
50	4518950	Filter Drier BFK-053S	1
51	452957800	Partition Assy.	1
52	452783300	Liquid Accumulator	1
53	452956300	Painted Right-Front Plate Assy.	1
54	4522601	Right Handle	1
55	452888500	Motor Support	1
56	452855600	DC Resin Motor(EHD80A90EC /SIC-71FW-F170-1)	1
57	452960400	Outdoor Fan	1
58	4523758	Nut M8 Left	1

13.3 Outdoor Unit: Multi Quattro-80 DCI

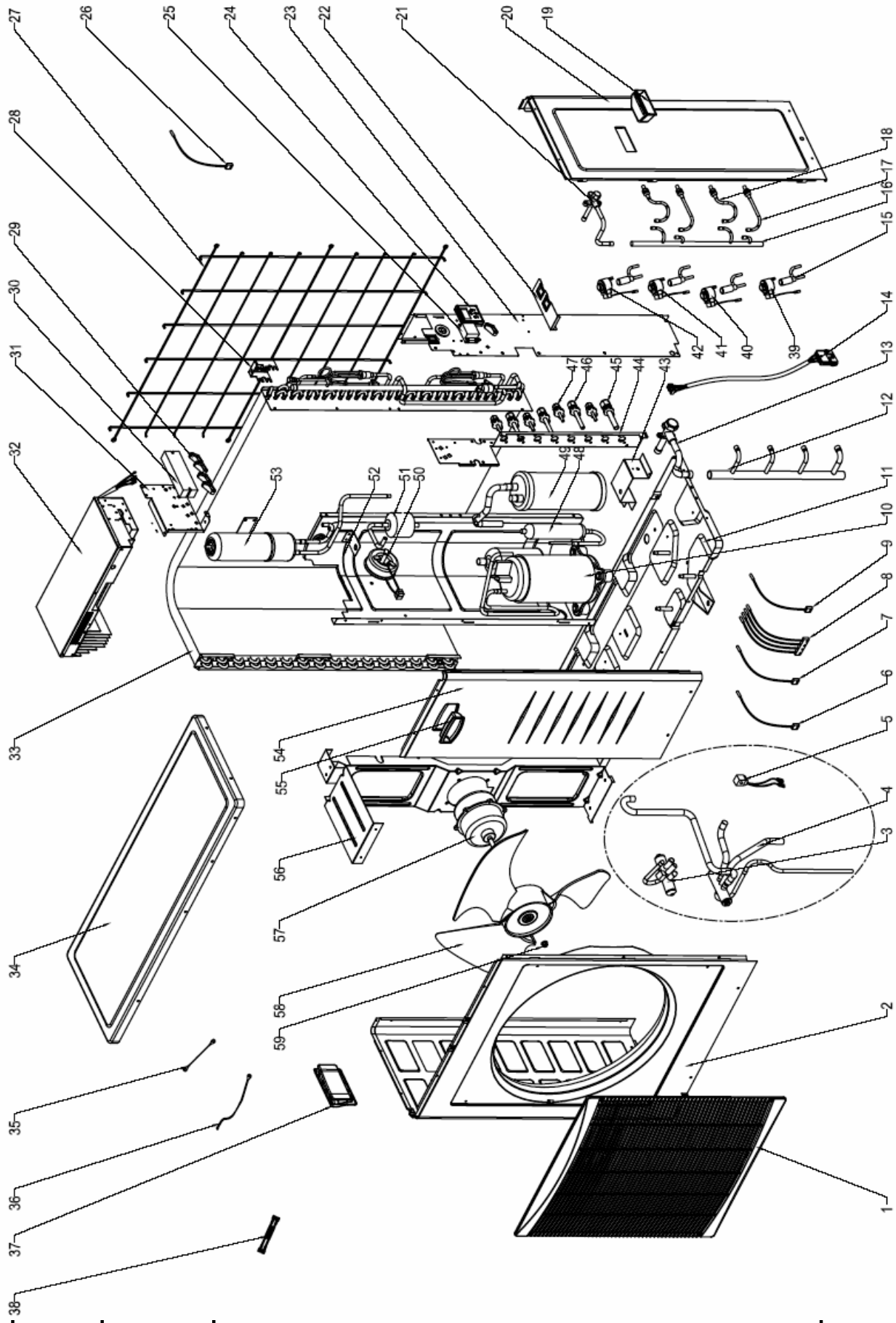

13.4 Outdoor Unit: Multi Quattro-80 DCI

No.	P/N	Description	Quant.
1	4522604	Outlet Grid	1
2	4523652	Painted Left Cabinet Assy.	1
3	4526522	4-way Vavle R410a	1
4	452803600	4-way Valve System Assy.	1
5	452956700	4-way Valve Coil	1
6	452966200	Compressor Top Thermistor(CTT)	1
7	452677601	Outdoor Coil Thermistor(OCT)	1
8	452956400	Return Gas Thermistor(RGT)	1
9	452956500	Suction Thermistor(SUCT)	1
10	453174100	Compressor Assy. TNB220FLBM	1
11	452809900	Base Plate Painting Assy.	1
12	452804800	Manifold Assy.	1
13	452783000	Low Pressure Stop Valve 5/8" R410a	1
14	452956600	Compressor Cable	1
15	4526827	Electronical Expansion Valve CAM-BD15 FKS-1	4
16	452805000	Distributing Pipe Assy.	1
17	452805100	Connect Pipe 2/Electronic Expansion Valve to High Pressure Stop Valve	2
18	452803000	Connect Pipe 1/Electronic Expansion Valve to High Pressure Stop Valve	2
19	4517772	Little Handle	1
20	452957700	Painted Side Plate Assy.	1
21	452783100	High Pressure Stop Vavle 3/8" R410a	1
22	452956200	Painted Stop Plate Assy.	1
23	452957600	Painted Right-back Plate Assy.	1
24	467300005	Display Board Assy.	1
25	453031800	3 Poles Terminal Block	1
26	4526774	Outdoor Air Thermistor(OAT)	1
27	453175500	Guard Net Painting Assy.	1
28	453083800	Support/OAT	1
29	204107	Cable Clip Nylon	5
30	453031700	10 Poles Terminal Block	1
31	453256700	Support Painting Assy./Electrical Box	1
32	452956100	DCI Outdoor Controller 3.1kW	1
33	452802500	Condensor System Assy.	1
34	4523657	Painted Top Cover Assy.	1
35	453256800	Ground Wire 1	1
36	453256900	Ground Wire 2	1
37	4522600	Left Handle	1
38	4526226	Power Lead Wire	1
39	452682803	EEV Coil(Green Connector 800mm)	1
40	452682801	EEV Coil(Yellow Connector 700mm)	1
41	452682800	EEV Coil(Red Connector 530mm)	1
42	452682802	EEV Coil(White Connector 530mm)	1
43	453256100	Support Painting Assy./Gas-Liquid Seperator	1
44	452811100	Valve Support Painting Assy.	1
45	452783500	Brass Connector With Flange 1/2"	1
46	452783501	Brass Connector With Flange 3/8"	3
47	452783502	Brass Connector With Flange 1/4"	4
48	452783600	Oil Seperator Assy.	1
49	452783200	Gas-Liquid Seperator	1
50	453256000	Chock Assy.	1
51	4518950	Filter Drier BFK-053S	1
52	452957800	Partition Assy.	1
53	452783300	Liquid Accumulator	1
54	452956300	Painted Right-Front Plate Assy.	1
55	4522601	Right Handle	1
56	452888500	Motor Support	1
57	452855600	DC Resin Motor(EHD80A90EC /SIC-71FW-F170-1)	1
58	452960400	Outdoor Fan	1
59	4523758	Nut M8 Left	1

APPENDIX A

INSTALLATION AND OPERATION MANUAL

- ▶ INSTALLATION MANUAL TRIO-72, QUATTRO-80 DCI