

DC INVERTER

INSTRUCTIONS D'INSTALLATION

FRANÇAIS

INSTALLATION INSTRUCTIONS

ENGLISH

INSTALLATION SANLEITUNG

DEUTSCH

INSTRUCCIONES DE INSTALACION

ESPAÑOL

ISTRUZIONE PER L'INSTALLAZIONE

ITALIANO

INSTALLATION INSTRUCTIONS

ENGLISH

1. LOCATION OF OUTDOOR UNIT
2. ELECTRICAL CONNECTION BETWEEN INDOOR AND OUTDOOR UNIT
3. INSTALLATION/SERVICE TOOLS (ONLY FOR R410A PRODUCT)
4. REFRIGERANT TUBING
5. FINAL TASKS

NOTE: This manual is for dual split applications only.
For indoor units installation, please refer to the installation manual supplied within the indoor unit package.

INSTALLATION INSTRUCTIONS FOR DCI SPLIT WALL MOUNTED AIR CONDITIONER

1

LOCATION OF OUTDOOR UNIT

Select the location considering the following:

OUTDOOR UNIT

1. The location must allow easy servicing and provide good air circulation as shown in fig 4.
2. The unit may be suspended from a wall by a bracket (Optional) or located in a free standing position on the floor (preferably slightly elevated).
3. If the unit is suspended, ensure that the bracket is firmly connected and the wall is strong enough to withstand vibrations.
4. Unit location should not disturb neighbors with noise or exhaust air stream.
5. Place the mounting pads under the unit legs.
6. Refer to figure 3 for allowed installation distances.
7. When the unit is installed on a wall, install the drain connector hose and drain plug as shown in fig 1 and fig 2.

Fig.1
1.Bottom of outdoor unit
2.Drain connector

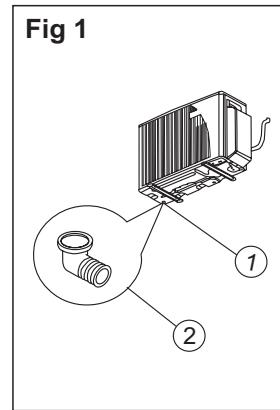

Fig.2
Drain installation
Example

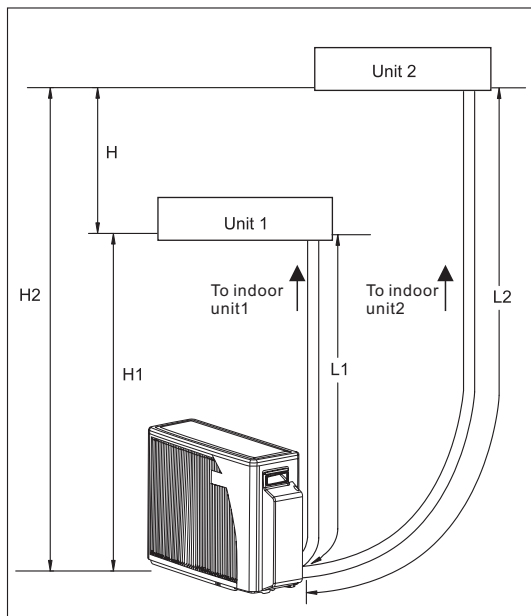
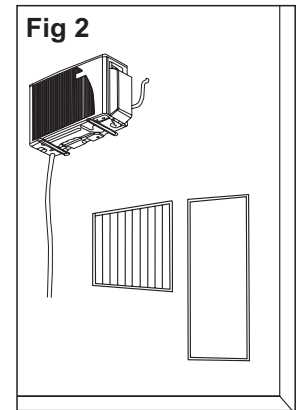

Fig 3

NOTES:

$L1 + L2 \leq 30m$ and $L1, L2 \leq 25m$

$H \leq 5m$

$H1, H2 \leq 10m$

No additional charge is required.

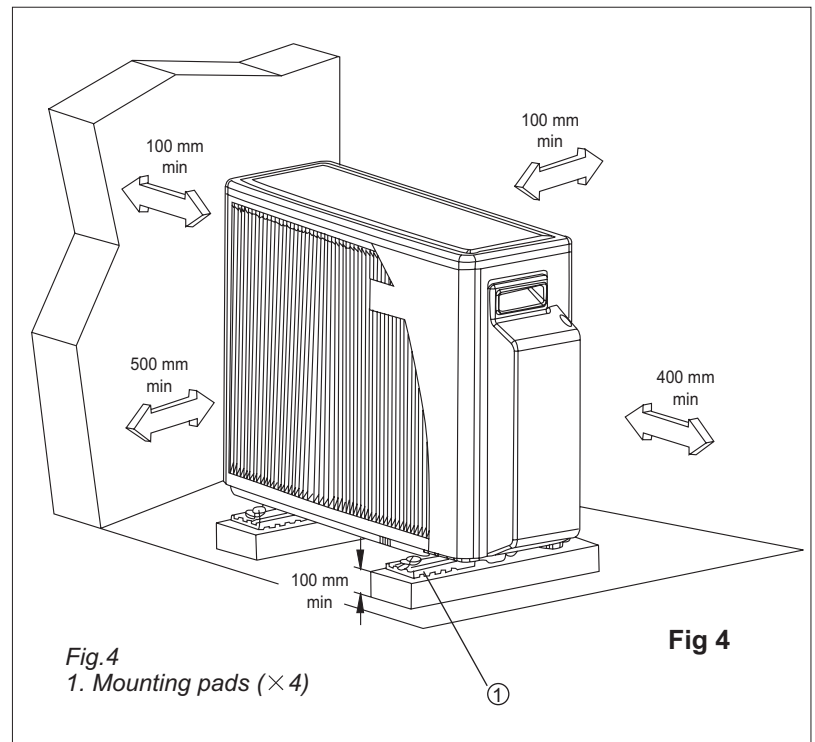

Fig.4

1. Mounting pads ($\times 4$)

Fig 4

ELECTRICAL CONNECTION BETWEEN INDOOR AND OUTDOOR UNIT

ELECTRICAL REQUIREMENTS

Electrical wiring and connections should be made by qualified electricians and in accordance with local electrical codes and regulation. The air conditioner units must be grounded. The air conditioner units must be connected to an adequate power outlet from a separate branch circuit protected by a time delay circuit breaker, as specified on unit's nameplate. Voltage should not vary beyond $\pm 10\%$ of the rated voltage.

1. Remove the power supply cable that is connected to the indoor units of WNG.
2. To connect the indoor units to the outdoor unit, use the following electrical cables.

Electrical connections:

Power input cable: $3 \text{ wires} \times 2.5 \text{ mm}^2$
 Cable between indoor and outdoor units: $4 \text{ wires} \times 1.5 \text{ mm}^2$

3. Prepare the cable ends for the power input and for the cables between outdoor and indoor units as shown in figure 6a and 6b respectively.
4. Connect the cable ends to the terminals of the indoor and outdoor units, as shown in fig7. Please select corresponding connection according to the different indoor units.
5. Secure the multiple wire power cable with the cable clamps.

Fig.5

1. Terminal
2. Cable clamp
3. Gas and liquid valves

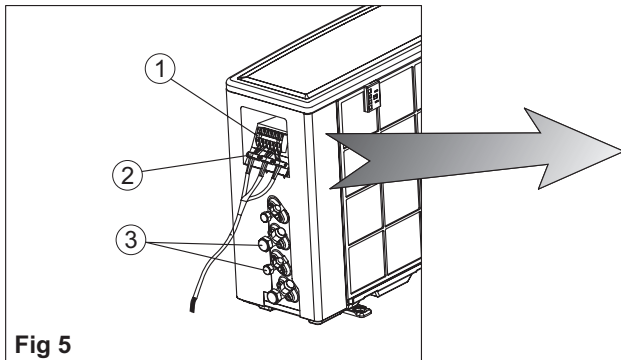

Fig 5

NOTES:

The wire color code can be selected by the installer.

• Power input cable

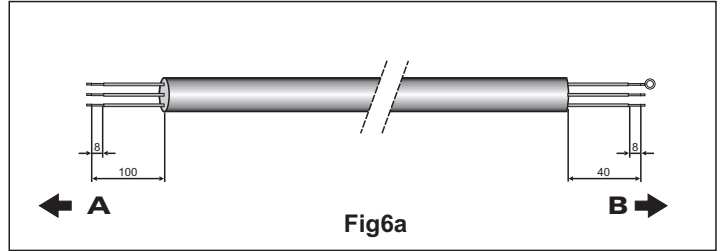

Fig6a

• Cable between indoor and outdoor units

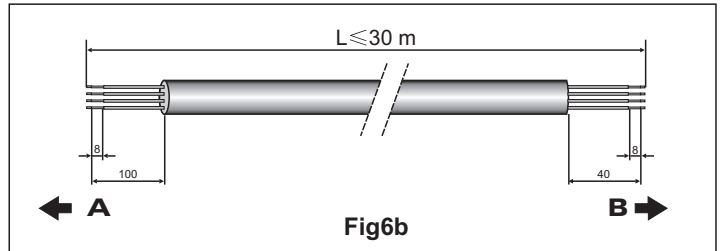

Fig6b

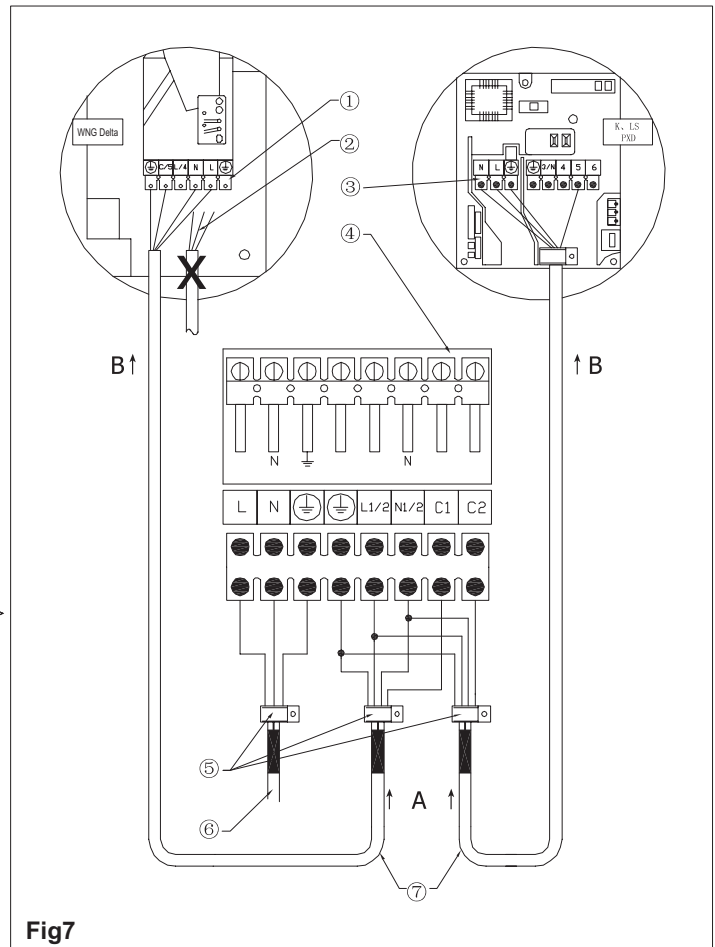

Fig7

Fig.7

1. Indoor unit terminal for WNG & Delta.
 2. Power cable in the indoor side.
 3. Indoor unit terminal for K.L.S.PXD.
 4. Outdoor unit terminal.
 5. Cable clamp.
 6. Power input cable.
 7. Outdoor unit connection cable.
- A. OUTDOOR B. INDOOR

INSTALLATION/SERVICE TOOLS (ONLY FOR R410A PRODUCT)

CAUTION

New Refrigerant Air Conditioner Installation

THIS AIR CONDITIONER ADOPTS THE NEW HFC REFRIGERANT (R410A) WHICH DOES NOT DESTROY OZONE LAYER. R410A refrigerant is apt to be affected by impurities such as water, oxidizing membrane, and oils because the working pressure of R410A refrigerant is approx. 1.6 times of refrigerant R22. Accompanied with the adoption of the new refrigerant, the refrigeration machine oil has also been changed. Therefore, during installation work, be sure that water, dust, former refrigerant, or refrigeration machine oil does not enter into the new type refrigerant R410A air conditioner circuit.







To prevent mixing of refrigerant or refrigerating machine oil, the sizes of connecting sections of charging port on main unit and installation tools are different from those used for the conventional refrigerant units. Accordingly, special tools are required for the new refrigerant (R410A) units. For connecting pipes, use new and clean piping materials with high pressure fittings made for R410A only, so that water and/or dust does not enter. Moreover, do not use the existing piping because there are some problems with pressure fittings and possible impurities in existing piping.

Changes in the product and components

In air conditioners using R410A, in order to prevent any other refrigerant from being accidentally charged, the service port diameter size of the outdoor unit control valve (3 way valve) has been changed. (1/2 UNF 20 threads per inch)

- In order to increase the pressure resisting strength of the refrigerant piping, flare processing diameter and opposing flare nuts sizes have been changed. (for copper pipes with nominal dimensions 1/2 and 5/8)

New tools for R410A

New tools for R410A	Applicable to R22 model		Changes
Gauge manifold	×		As the working pressure is high, it is impossible to measure the working pressure using conventional gauges. In order to prevent any other refrigerant from being charged, the port diameters have been changed.
Charge hose	×		In order to increase pressure resisting strength, hose materials and port sizes have been changed (to 1/2 UNF 20 threads per inch). When purchasing a charge hose, be sure to confirm the port size.
Electronic balance for refrigerant charging	○		As working pressure is high and gasification speed is fast, it is difficult to read the indicated value by means of charging cylinder, as air bubbles occur.
Torque wrench (nominal dia. 1/2, 5/8)	×		The size of opposing flare nuts have been increased. Incidentally, a common wrench is used for nominal diameters 1/4 and 3/8.
Flare tool (clutch type)	○		By increasing the clamp bar's receiving hole size, strength of spring in the tool has been improved.
Gauge for projection adjustment	—		Used when flare is made by using conventional flare tool.
Vacuum pump adapter	○		Connected to conventional vacuum pump. It is necessary to use an adapter to prevent vacuum pump oil from flowing back into the charge hose. The charge hose connecting part has two ports -- one for conventional refrigerant (7/16 UNF 20 threads per inch) and one for R410A. If the vacuum pump oil (mineral) mixes with R410A a sludge may occur and damage the equipment.
Gas leakage detector	×		Exclusive for HFC refrigerant.

- Incidentally, the "refrigerant cylinder" comes with the refrigerant designation (R410A) and protector coating in the U.S's ARI specified rose color (ARI color code: PMS 507).
- Also, the "charge port and packing for refrigerant cylinder" requires 1/2 UNF 20 threads per inch corresponding to the charge hose's port size.

4

REFRIGERANT TUBING

CONNECT THE INDOOR TO THE OUTDOOR UNIT

The indoor unit contains a small quantity of nitrogen. Do not unscrew the nuts from the unit until you are ready to connect the tubing. The outdoor unit is supplied with sufficient refrigerant charge (R410A). Refer to outdoor unit nameplate.

To prevent crushing, bend tubes using a bending tool.

NOTE: Use refrigeration R410A type copper tubing only.

1. Open the valve cover.
2. Use tubing diameter that corresponds to the tubing diameter of the indoor and outdoor units. Note that the liquid and suction tubes have different diameters. (See tube size, torque tightening table.)
3. Place flare nuts on tube ends before preparing them with a flaring tool. Use the flare nuts that are mounted on the supplied outdoor and indoor units.
4. Connect the all ends of the tubing to the indoor and outdoor units. Notice the sign. All ends should correspond one by one.
5. Insulate each tube separately, and their unions, with at least 13 mm thick of insulation. Wrap the refrigerant tubing, drain hose and electric cables together with a vinyl tape (UV protected).

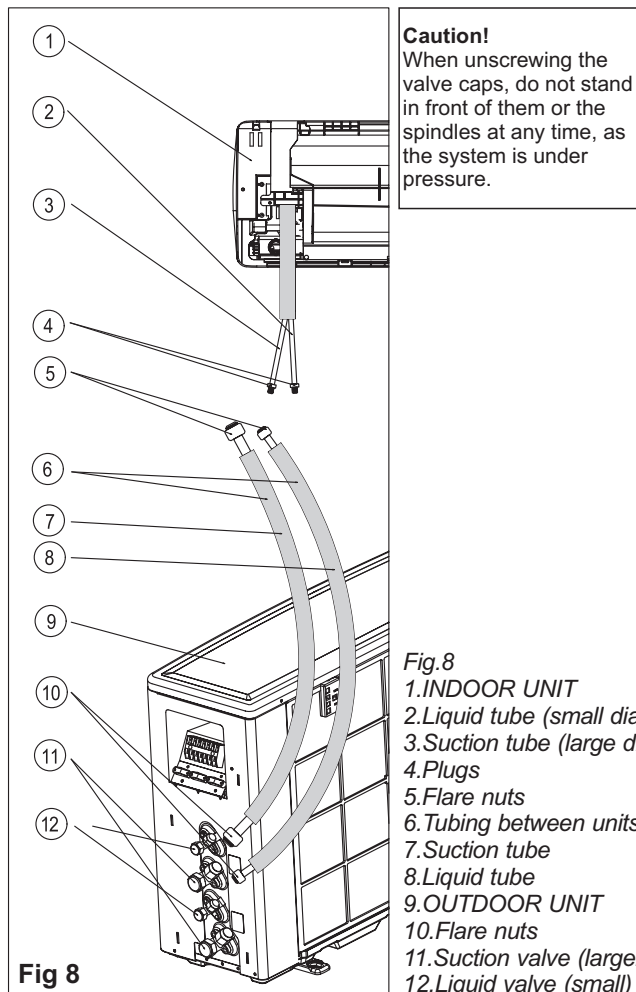

Caution!
When unscrewing the valve caps, do not stand in front of them or the spindles at any time, as the system is under pressure.

Fig.8
1. INDOOR UNIT
2. Liquid tube (small dia.)
3. Suction tube (large dia.)
4. Plugs
5. Flare nuts
6. Tubing between units
7. Suction tube
8. Liquid tube
9. OUTDOOR UNIT
10. Flare nuts
11. Suction valve (larger)
12. Liquid valve (small)

NOTE: 1# valves connect IDU-1.
2# valves connect IDU-2.
All ends should correspond one by one.

Tightening torques of unions and valve caps:

TUBE SIZE	TORQUE
Liquid line 1/4"	15-20 N.M.
Suction line 3/8"	30-35 N.M.
Suction line 1/2"	50-54 N.M.
Suction line 5/8"	75-78 N.M.

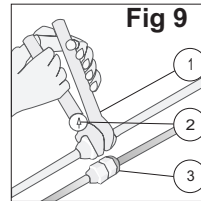

Fig.9
1. Wrench
2. Torque wrench
3. Union

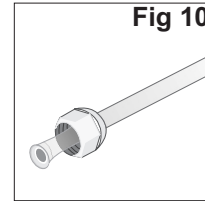

Fig.10
To prevent refrigerant leakage, coat the flared surface with refrigeration oil

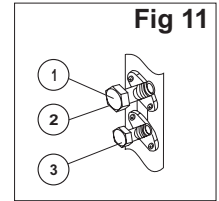

Fig.11
1. Suction valve
2. Service port
3. Liquid valve

EVACUATION OF THE REFRIGERATION TUBES AND THE INDOOR UNIT

After connecting the unions of the indoor and outdoor units, purge the air from the tubes and indoor unit as follows:

1. Connect the charging hoses with a push pin to the low side of the charging set and the service port of the suction valve. Be sure to connect the end of the charging hose with the push pin to the service port.
2. Connect the center hose of the charging set to a vacuum pump.
3. Turn on the power switch of the vacuum pump, turn off the high side switch and make sure that the needle in the gauge moves from 0 MPa (0cm Hg) to -0.1 MPa (-76cm Hg). Let the pump run for fifteen minutes.
4. Close the valve of the low side of the charging set and turn off the vacuum pump. Note that the needle in the gauge should not move after approximately five minutes.
5. Not any problem for five minutes, turn on the power switch of the vacuum pump and open the valve of the low side of the charging set.
6. Disconnect the charging hose from the vacuum pump and from the service ports of the suction valve.
7. Tighten the service port caps of suction valve.
8. Redo 1 to 7 for other indoor units.
9. Remove the valve caps from all valves, and open them using a hexagonal Allen wrench.
10. Remount valve caps onto all of the valves.
11. Check for gas leaks from all the connecting position. Test with electronic leak detector or with a sponge immersed for soapy water for bubbles.

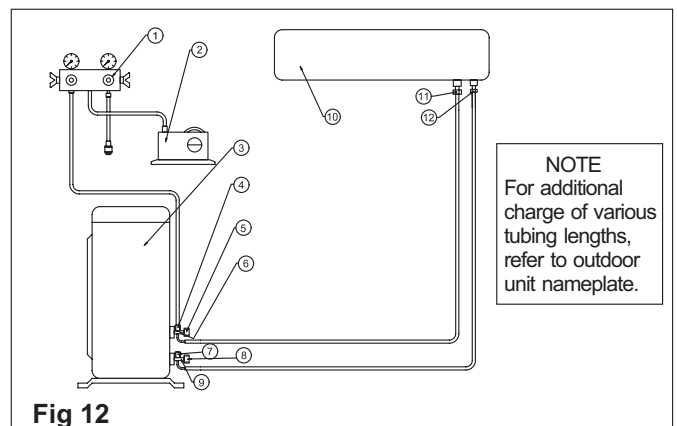

Fig.12
1. Charging set
2. Vacuum pump
3. OUTDOOR UNIT
4. Service valve
5. Cap
6. Suction valve
7. Service valve*
8. Cap
9. Liquid valve
10. INDOOR UNIT
11. Suction flare connection
12. Liquid flare connection
*In some models only

NOTE
For additional charge of various tubing lengths, refer to outdoor unit nameplate.

5

FINAL TASKS

1. Check all valve caps and ensure that they had tightened properly. Close the valve cover.
2. Fill gaps on the wall between hole sides and tubing with sealer.
3. Attach wiring and tubing to the wall with clamps where necessary.
4. Operate the unit for no less than 5 minutes at heating or cooling mode.
5. Explain filter removal, cleaning and installation.
6. Operate the air conditioner together with the customer and explain all functions.
7. Give the operating and installation manuals to the customer.

