

**Comfort Range**

**DC Inverter Split system for Wall / ceiling mounting**

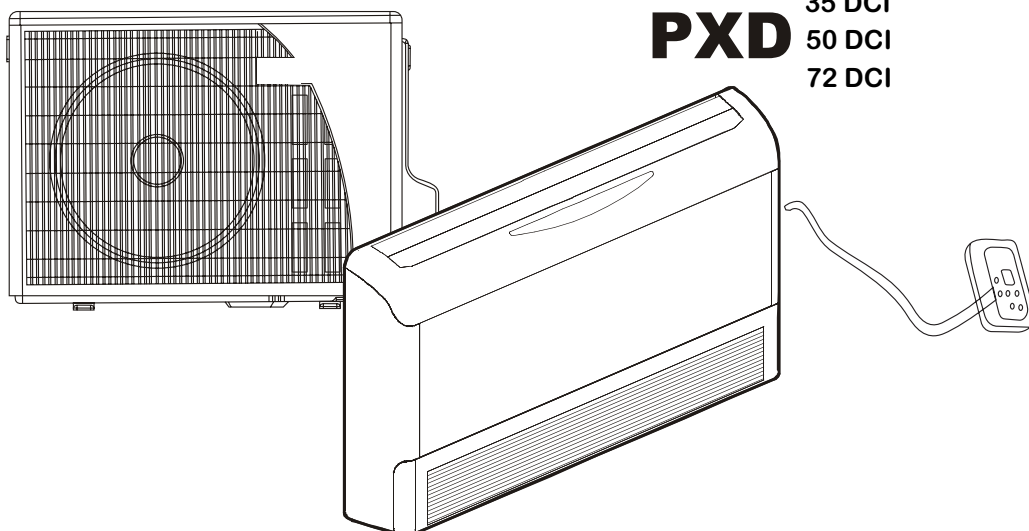

Heat pump



**PXD**  
35 DCI  
50 DCI  
72 DCI

**DCINVERTER**

The appliance shall not be installed in the laundry.





## **IT IS MANDATORY TO CUT OFF POWER SUPPLY BEFORE STARTING TO WORK IN THE ELECTRIC CASING BOXES.**

---

### **GENERAL RECOMMENDATIONS**

- *Congratulations for having selected an our air conditioner.*

### **SAFETY DIRECTIONS**

- *Follow the safety rules in force when you are working on your appliance.*
- *Installation and maintenance of the equipment must only be performed by qualified specialists in accordance with the rules of good workmanship and prevailing standards and instructions.*
- *Make sure that the power supply and its frequency are adapted to the required electric current of operation, taking into account specific conditions of the location and the current required for any other appliance connected with the same circuit.*

### **WARNING**

- *Cutoff power supply before starting to work on the appliance. The manufacturer declines any responsibility and the warranty becomes void if these instructions are not respected.*
- *If you meet a problem, please call the Technical Department of your area.*
- *If possible, assemble the mandatory or optional accessories before placing the appliance on its final location.(see instructions provided with each accessory)*
- *In order to become fully familiar with the appliance, we suggest to read also our Technical Instructions.*
- *The information contained in these Instructions are subject to modification without advance notice.*
- *For appliances with supplementary heaters, the minimum clearance from the appliance to combustible is 50cm other wise, it will cause fire.*

**PRECAUTIONS**

 <b>Danger</b>	This sign warns of death or serious injury.
---	---

- Do not attempt to install this air conditioner by yourself.
- This unit contains no user-serviceable parts. Always consult authorized service personnel for repairs.
- When moving, consult authorized service personnel for disconnection and installation of the unit.
- Do not become excessively chilled by staying for lengthy periods in the direct cooling airflow.
- Do not insert fingers or objects into the outlet port or intake grilles.
- Do not start and stop air conditioner operation by disconnecting the power supply cord and so on.
- Take care not to damage the power supply cord.
- In the event of a malfunction (burning smell, etc.), immediately stop operation, disconnect the power supply plug, and consult authorized service personnel.
- If the power supply cord of this appliance is damaged, it should only be replaced by the authorized service personal, since special purpose tools and specified cord are required.
- The appliance is not intended for use by young children of infirm persons without supervision.
- Please pre-heat the air conditioner for at least 12 hours before operation. If use it for a long time, please keep the power on.

 <b>Caution</b>	This sign warns of damage to property.
--	--

- Provide occasional ventilation during use.
- Do not direct air flow at fireplaces or heating apparatus.
- Do not climb on, or place objects on, the air conditioner.
- Do not hang objects from the indoor unit.
- Do not set flower vases or water containers on top of air conditioners.
- Do not expose the air conditioner directly to water.
- Do not pull power supply cord.
- Turn off power source when not using the unit for extended periods.
- Check the condition of the installation stand for damage.
- Do not place animals or plants in the direct path of the air flow.
- Do not drink the water drained from the air conditioner.
- Do not use in applications involving the storage of foods, plants or animals, precision equipment, or art works.
- Connection valves become hot during Heating; handle with care.
- Do not apply any heavy pressure to radiator fins.
- Operate only with air filters installed.
- Do not block or cover the intake grille and outlet port.
- Ensure that any electronic equipment is at least one metre away from either the indoor or outdoor units.
- Avoid installing the air conditioner near a fireplace or other heating apparatus.
- When installing the indoor and outdoor unit, take precautions to prevent access to infants.
- Do not use inflammable gases near the air conditioner.

**OPERATION TIPS**

- Set a suitable room temperature; excessively low room temperature is not good for your health and wastes electricity. Avoid frequent setting of the temperature.
- During cooling, avoid direct sun. Keep curtains and blinds closed. Close doors and windows to keep the cool air in the room.
- Avoid generating heat or using of heating appliances while the air conditioner in cooling mode.
- Make sure that the air flap is positioned properly: horizontal flow in cooling and downward vertical flow for heating.
- Keep the room temperature uniform by adjusting the left/right vertical air blades.
- Position the air flap and the left/right air blades in such a manner as to prevent your body from being exposed directly to air drafts.
- During prolonged operation, ventilate the room occasionally by opening a window from time to time.
- In a power failure, the microprocessor memory is retained. When restarted, operation will be resumed in the last mode of operation. However, if the timer was used, the unit will be turned off by the timer only if the remote control is aimed at the unit. Otherwise the power failure will cause the timer data to be erased from the microprocessor memory.
- After turning on, allow more than 3 minutes for cooling, heating or dry operation to start.
- When DRY mode is used, make sure that the room temperature is between 20°C and 27°C. When used out of this range, the unit may protect itself and become inoperative.
- When COOL or DRY modes are used, make sure that the room's relative humidity is below 78%. If the unit is used for a prolonged periods of time in high humidity, moisture may form on the air outlet and drip down.
- Remote control signals may not be received if the indoor unit controls cover is exposed to direct sunlight or strong light. In such a case, block the sunlight or dim the lighting.
- The remote control is operative in a range of 8 meters. If you are out of range, the remote control may have difficulties in transmitting signals.

**SUMMARY****DESCRIPTION**

Installation/service tools.....	5
Operating temperature range.....	6
Dimensions of Indoor Unit .....	6
Dimensions of Outdoor Units.....	6

**INSTALLATION**

Location of the Indoor Unit .....	7-8
Location of the Outdoor Unit.....	9
Refrigerant Line .....	10
Installation.....	11-16
Electrical Connections .....	17-20

**MAINTENANCE**

Scheduled Maintenance .....	21-22
-----------------------------	-------

---

**CONTENTS OF PARCEL**

- 1 PXD.
- 1 wall support. (supplied fitted to the unit).
- 1 bag containing hardware.
- 1 bag containing documentation.
- 1 IR remote control + support.
- 1 template for positioning connection tubing. + connection tubing fixing clamps
- 1 assembly template (distance between mounting holes)
- 1 sensor connecting cable
- 1 active charcoal filter and its support
- 1 cable(7m)+ control display unit

## INSTALLATION/SERVICE TOOLS

### CAUTION

#### New Refrigerant Air Conditioner Installation

**THIS AIR CONDITIONER ADOPTS THE NEW HFC REFRIGERANT (R410A) WHICH DOES NOT DESTROY OZONE LAYER.** R410A refrigerant is apt to be affected by impurities such as water, oxidizing membrane, and oils because the working pressure of R410A refrigerant is approx. 1.6 times of refrigerant R22. Accompanied with the adoption of the new refrigerant, the refrigeration machine oil has also been changed. Therefore, during installation work, be sure that water, dust, former refrigerant, or refrigeration machine oil does not enter into the new type refrigerant R410A air conditioner circuit.







To prevent mixing of refrigerant or refrigerating machine oil, the sizes of connecting sections of charging port on main unit and installation tools are different from those used for the conventional refrigerant units. Accordingly, special tools are required for the new refrigerant (R410A) units. For connecting pipes, use new and clean piping materials with high pressure fittings made for R410A only, so that water and/or dust does not enter. Moreover, do not use the existing piping because there are some problems with pressure fittings and possible impurities in existing piping.

#### Changes in the product and components

In air conditioners using R410A, in order to prevent any other refrigerant from being accidentally charged, the service port diameter size of the outdoor unit control valve (3 way valve) has been changed. (1/2 UNF 20 threads per inch)

- In order to increase the pressure resisting strength of the refrigerant piping, flare processing diameter and opposing flare nuts sizes have been changed. (for copper pipes with nominal dimensions 1/2 and 5/8)

#### New tools for R410A

New tools for R410A	Applicable to R22 model	Changes
Gauge manifold	×	 As the working pressure is high, it is impossible to measure the working pressure using conventional gauges. In order to prevent any other refrigerant from being charged, the port diameters have been changed.
Charge hose	×	 In order to increase pressure resisting strength, hose materials and port sizes have been changed (to 1/2 UNF 20 threads per inch). When purchasing a charge hose, be sure to confirm the port size.
Electronic balance for refrigerant charging	○	 As working pressure is high and gasification speed is fast, it is difficult to read the indicated value by means of charging cylinder, as air bubbles occur.
Torque wrench (nominal dia. 1/2, 5/8)	×	 The size of opposing flare nuts have been increased. Incidentally, a common wrench is used for nominal diameters 1/4 and 3/8.
Flare tool (clutch type)	○	 By increasing the clamp bar's receiving hole size, strength of spring in the tool has been improved.
Gauge for projection adjustment	—	Used when flare is made by using conventional flare tool.
Vacuum pump adapter	○	 Connected to conventional vacuum pump. It is necessary to use an adapter to prevent vacuum pump oil from flowing back into the charge hose. The charge hose connecting part has two ports -- one for conventional refrigerant (7/16 UNF 20 threads per inch) and one for R410A. If the vacuum pump oil (mineral) mixes with R410A a sludge may occur and damage the equipment.
Gas leakage detector	×	 Exclusive for HFC refrigerant.

- Incidentally, the "refrigerant cylinder" comes with the refrigerant designation (R410A) and protector coating in the U.S's ARI specified rose color (ARI color code: PMS 507).
- Also, the "charge port and packing for refrigerant cylinder" requires 1/2 UNF 20 threads per inch corresponding to the charge hose's port size.

## OPERATING TEMPERATURE RANGE

		Indoor		Outdoor	
		DB[°C]	WB[°C]	DB[°C]	WB[°C]
Cooling	Upper Limit	26	19	46	NA
	Lower Limit	12	9	-10	NA
Heating	Upper Limit	27	NA	24	18
	Lower Limit	10	NA	-15	-16

## DIMENSIONS OF INDOOR UNIT

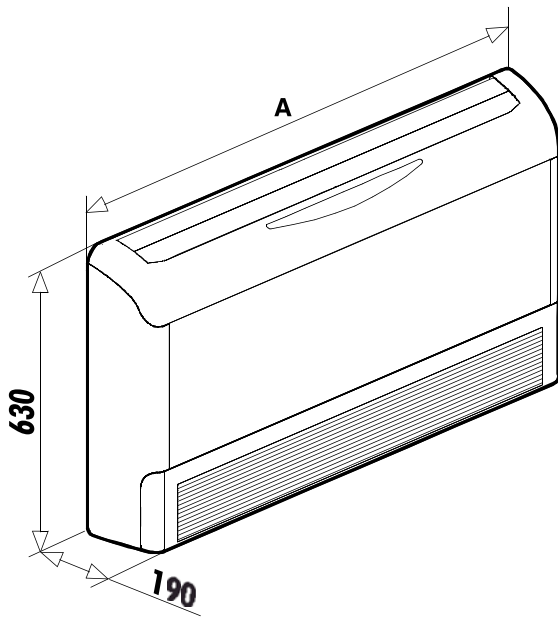

**MODEL 35 DCI**

**A = 820mm**

**MODEL 50-72 DCI**

**A = 1200mm**

## DIMENSIONS OF OUTDOOR UNITS

MODEL	A	B	C	D	E	F
DCR 35	245	545	260	760	472	50
YBD 018	290	610	293	795	500	40
DCI 72Z	340	864	378	950	527	48

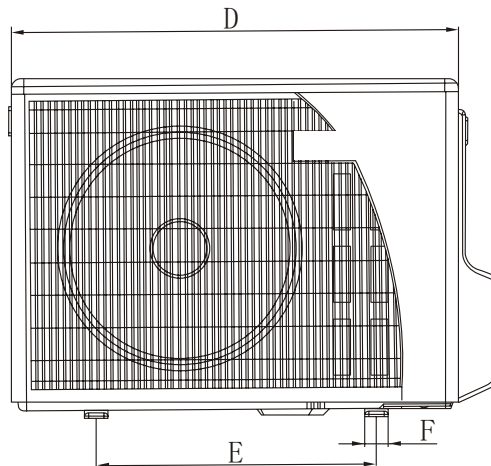
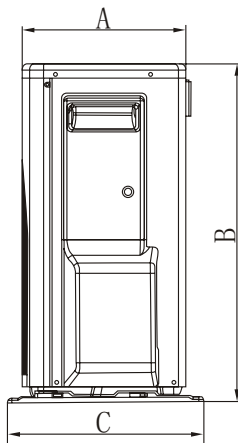

**INSTALLATION OF THE PXD INDOOR UNIT**

- Install the wall support of the PXD using the installation template supplied with the unit.
- The cut-outs for the unit are shown on this template.

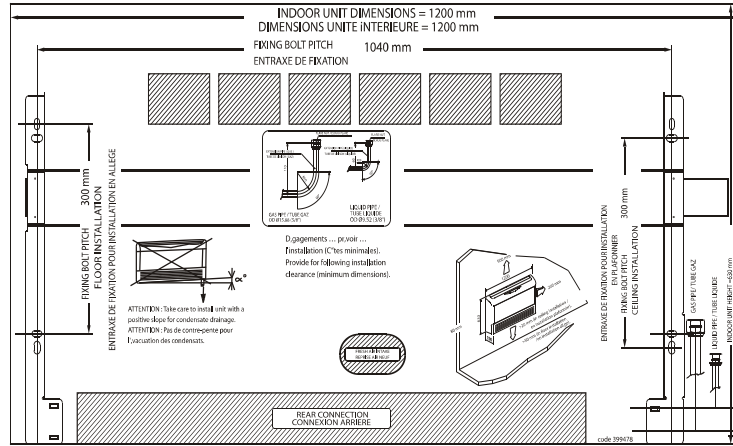

- Reminder of **MINIMUM** clearances to be provided.

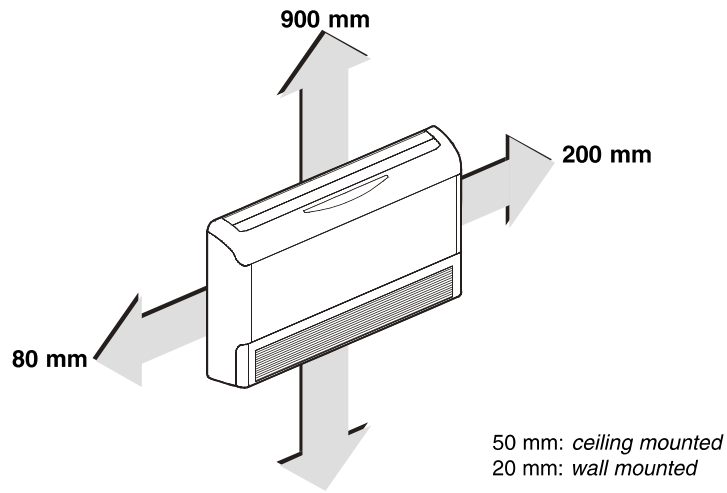

- Coolant connections can be made on the LH side, on the RH side or at the rear.
- Condensate evacuation possibilities: right, left, rear and front in the case of a ceiling mounted unit. (2 condensate outputs are available on the recovery tray).

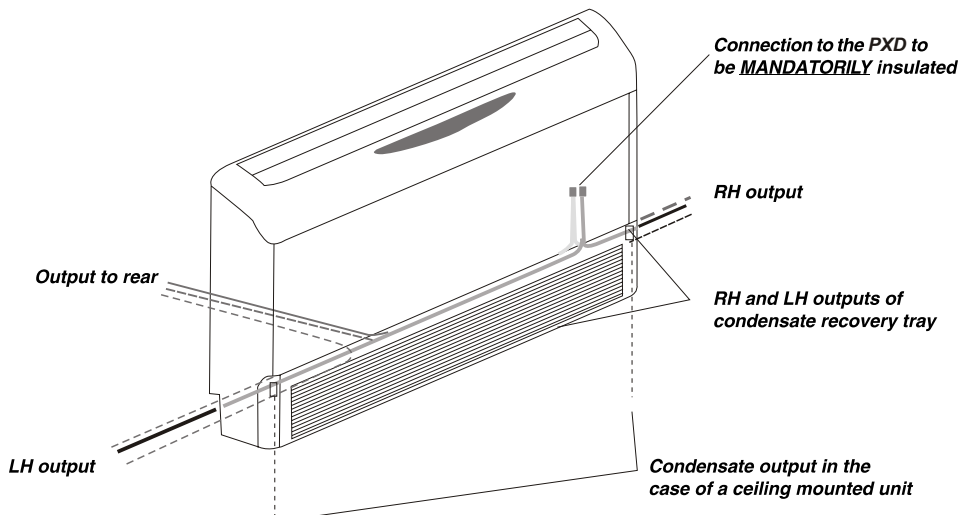



## INSTALLATION

- Remove the wall support mounted at the rear of your PXD.

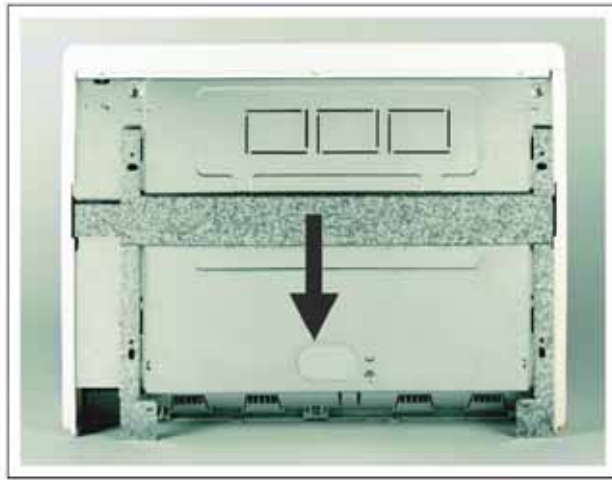

- To install the wall support, locate the template in order to observe the correct distance between mounting holes marked on it.

### CAUTION- be careful with the condensate evacuation point:

After determining the outlet for the condensate evacuation (LH, RH, rear), make sure that the wall mounting is installed with a slope which favours this evacuation.

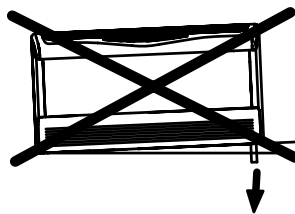

Condensates evacuation

$\alpha^\circ$  - Take care to install unit with a positive slope for condensate drainage

- Secure the wall support with 4 screws (not supplied).

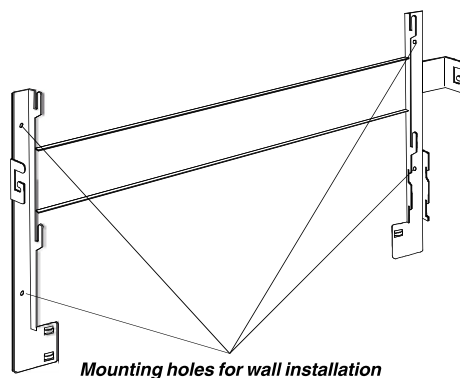

Mounting holes for wall installation

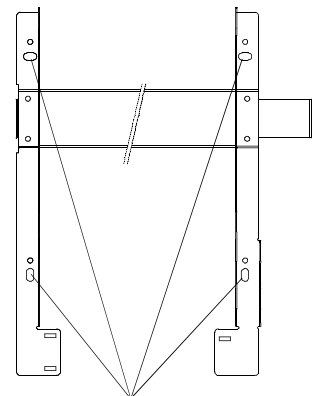

Location of threaded rods (Dia 8 mm max.) for ceiling installation

**INSTALLATION OF THE OUTDOOR UNIT**

- Minimum clearance to respect (in mm).

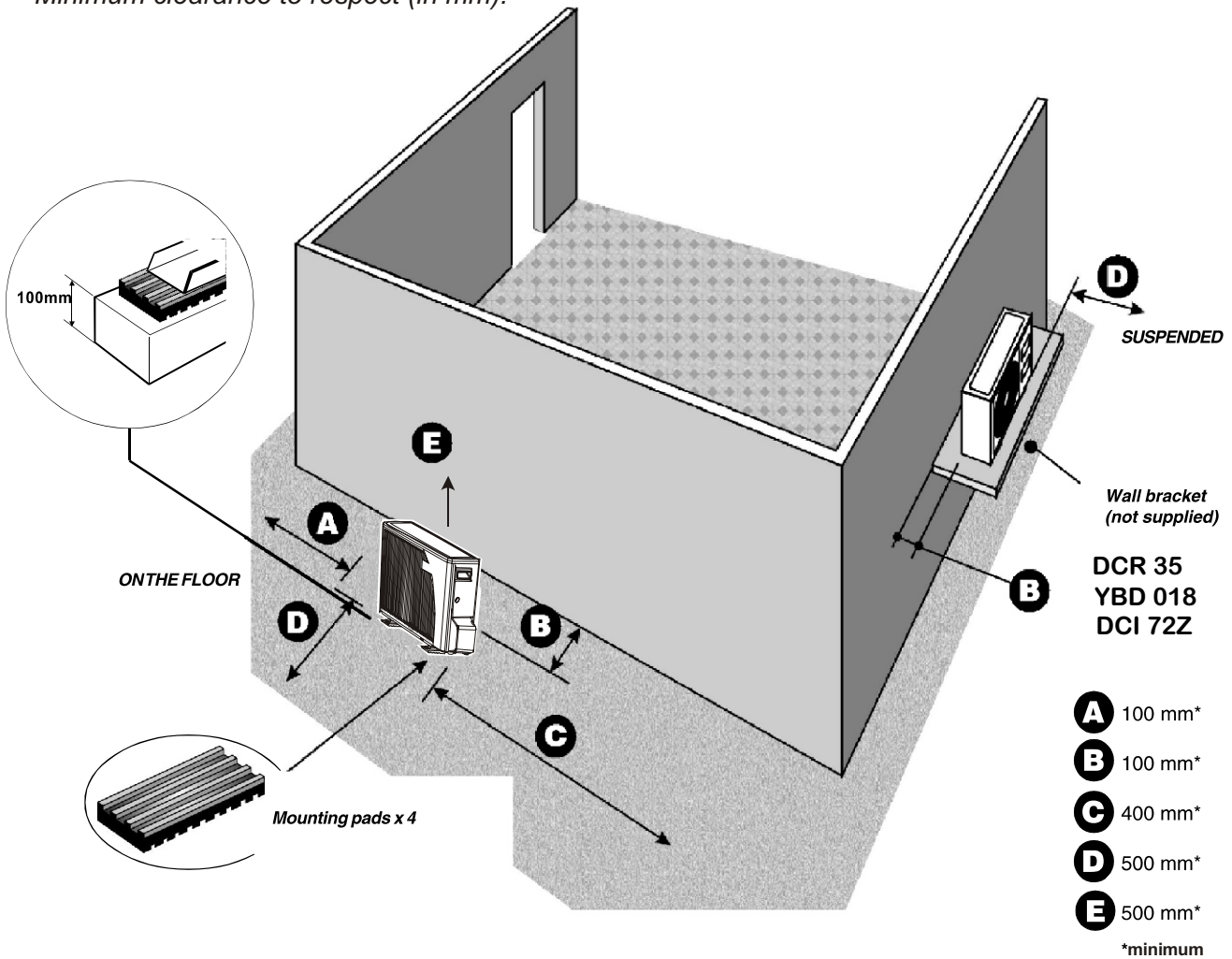

**DRAINING CONDENSATES**

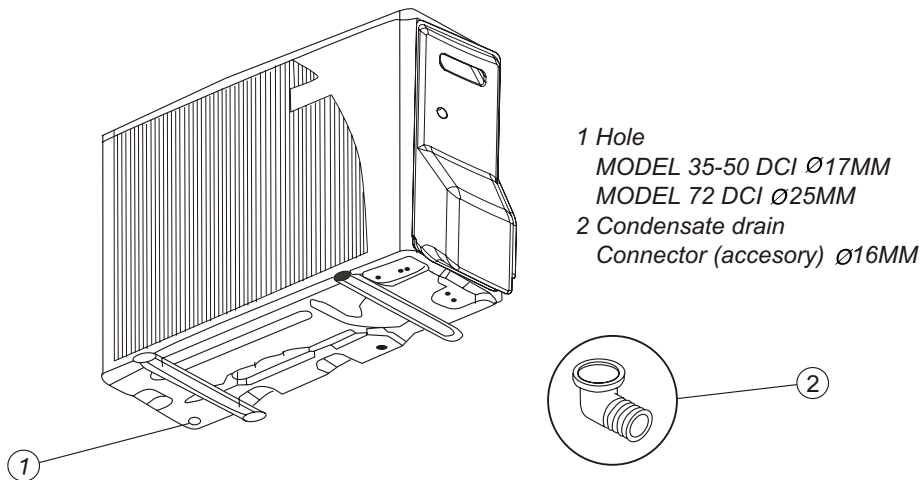

**CAUTION**

If the heat pump outdoor unit is installed in an area where the outdoor temperature may fall below + 1°C, it is mandatory to provide a system preventing any risk of freezing of the condensate (e.g. heating wire).

## REFRIGERANT CONNECTIONS

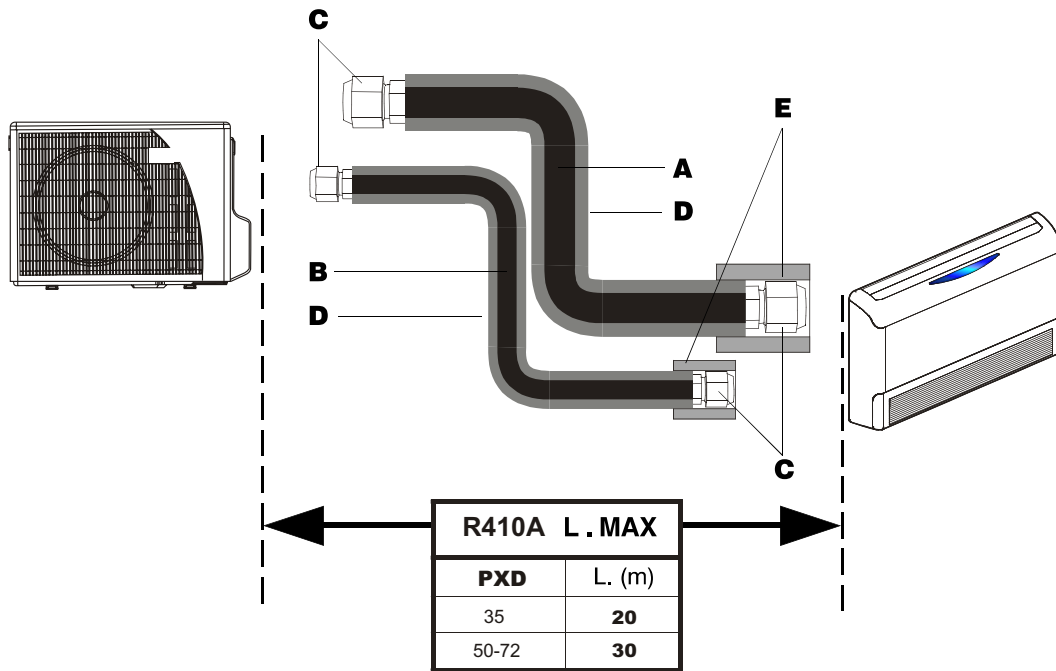

- A «Gas» pipe
- B «Liquid» pipe
- C Flare nut
- D Pipe insulation (6 mm min.)
- E Insulation sleeve

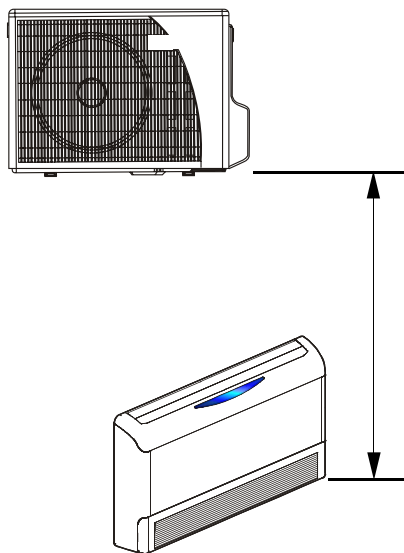

**DCR 35-YBD 018**

**H=10m MAX\***

**DCI 72Z**

**H=15m MAX\***

\* H=7m MAX without siphon

H>7m Fit a siphon on the gas line every 3m

- The indoor unit may be installed above or below the unit
- The flare couplings are available as accessories in standard lengths of 2.5, 5 and 8m.
- The pipes are delivered coiled and equipped with flare nuts.
- Carefully uncoil the pipes in the opposite direction from the turns so as not to flatten them.

**INSTALLATION OF TUBING ON WALL SUPPORT**

- The main advantage of your PXD product is the possibility of locating the coolant tubing on the wall support before installing the unit (using the template supplied).
- Place the tube locating template on the wall support.

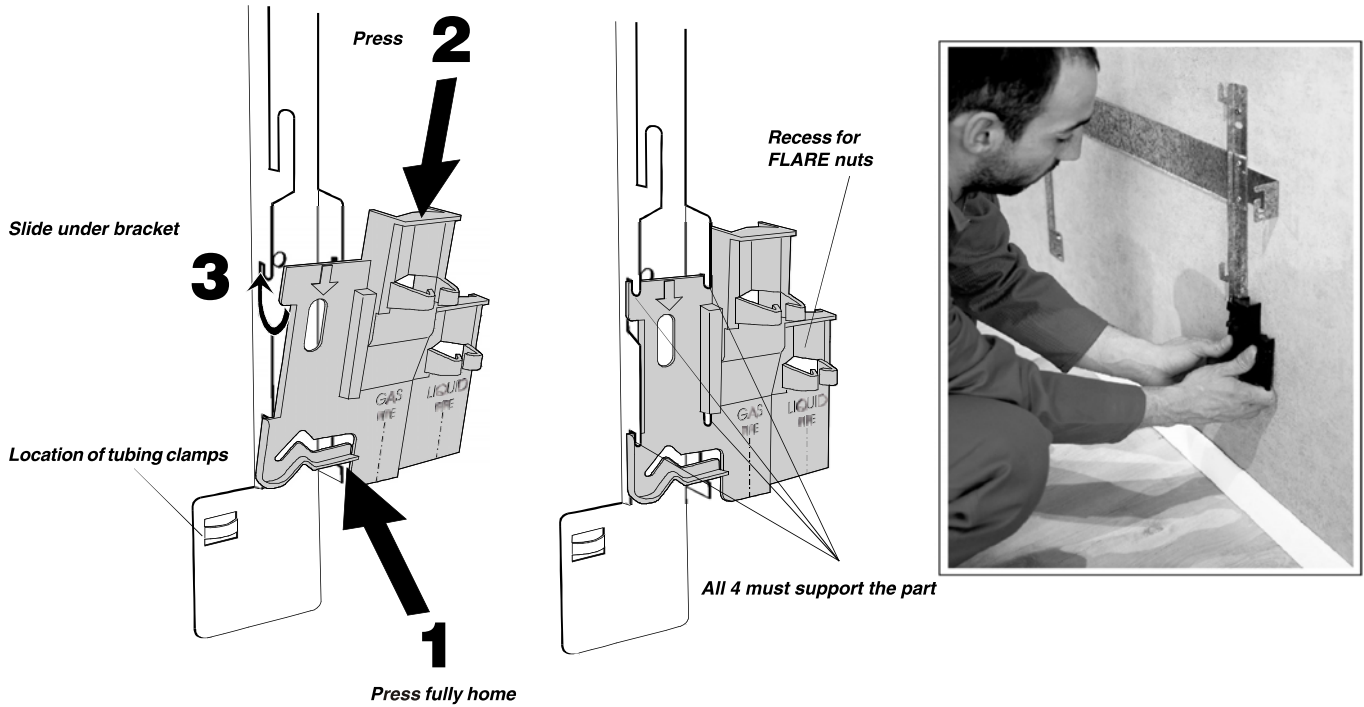

**INSTALLATION OF TUBING ON WALL SUPPORT**

- After choosing your coolant tubing input location (right, left or rear), you can set up your tubing. To do this, use the installation template in order to form the tubes correctly and thus facilitate connection.

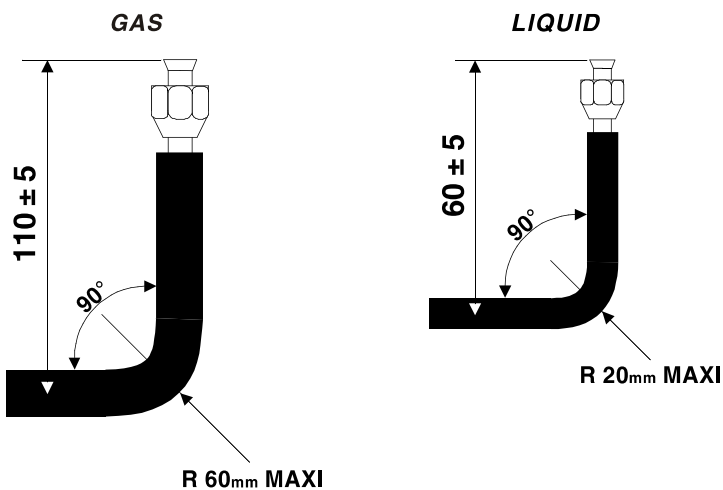

	Ø GAS tube	Ø LIQUID tube
PXD-35-DCI	3/8"	1/4"
PXD-50-DCI	1/2"	1/4"
PXD-72-DCI	5/8"	3/8"

## INSTALLATION OF TUBING ON WALL SUPPORT

- Locate the LIQUID tube above the GAS tube.

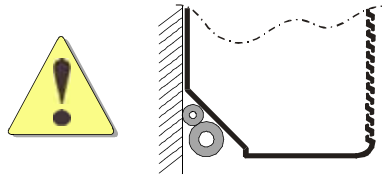

- Fit the nuts of the (for med) tubing into the recess provided on the template.
- Secure the tubing with the clamps provided.
- Remove the tubing template; you can now install your unit on its support.

### NOTE

#### output to the rear

- The slanted hole prevents condensates or rain from entering the unit.
- Fit a Dia. 70 mm sleeve into the hole.

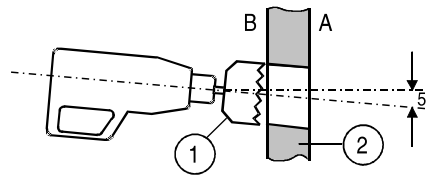

- A Outside
- B Inside
- 1 Drill Dia. 70 mm
- 2 Wall

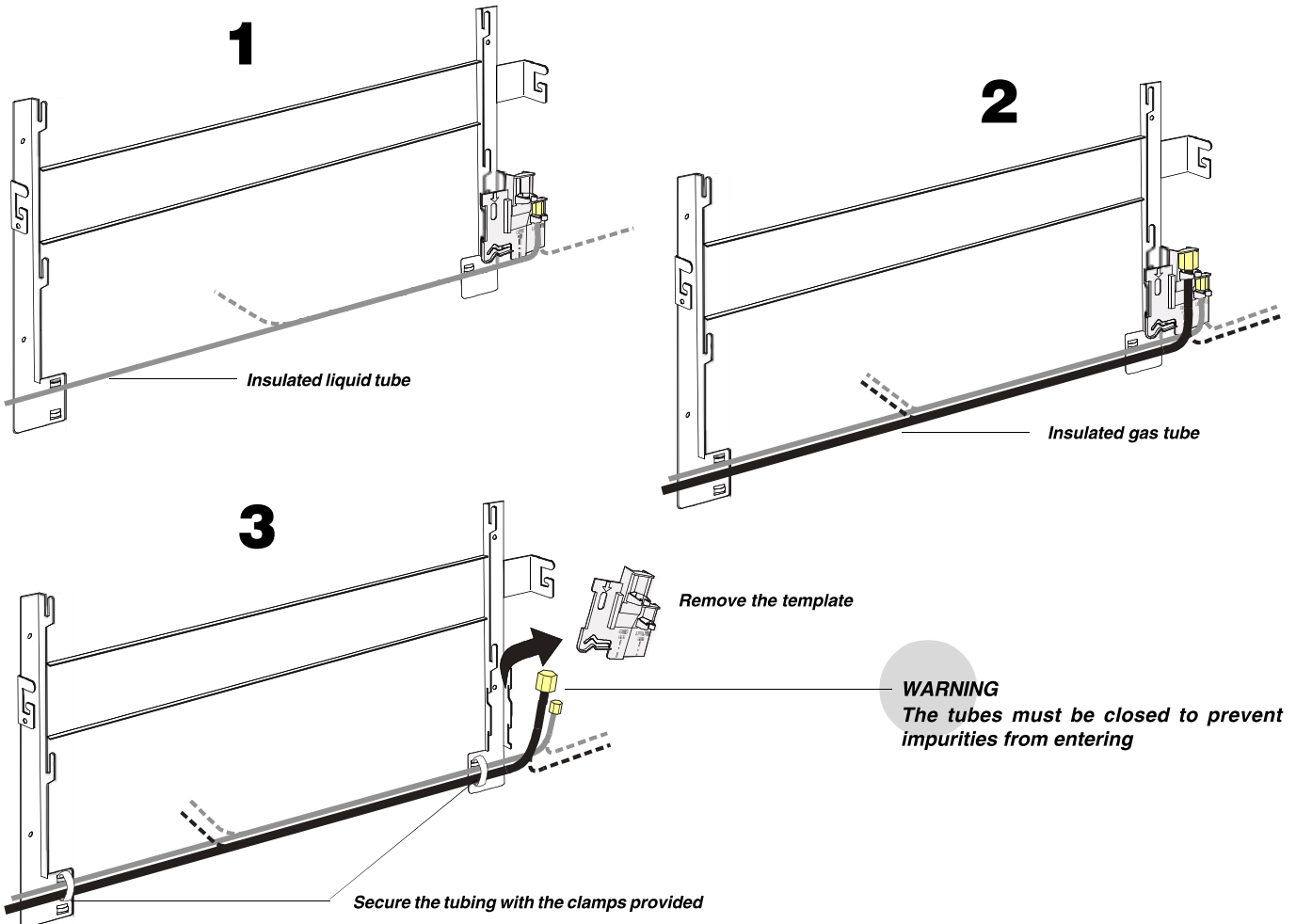

**INSTALLATION OF THE INDOOR UNIT PXD**

- On the PXD, remove: The intake gril. The LH and RH side panels.

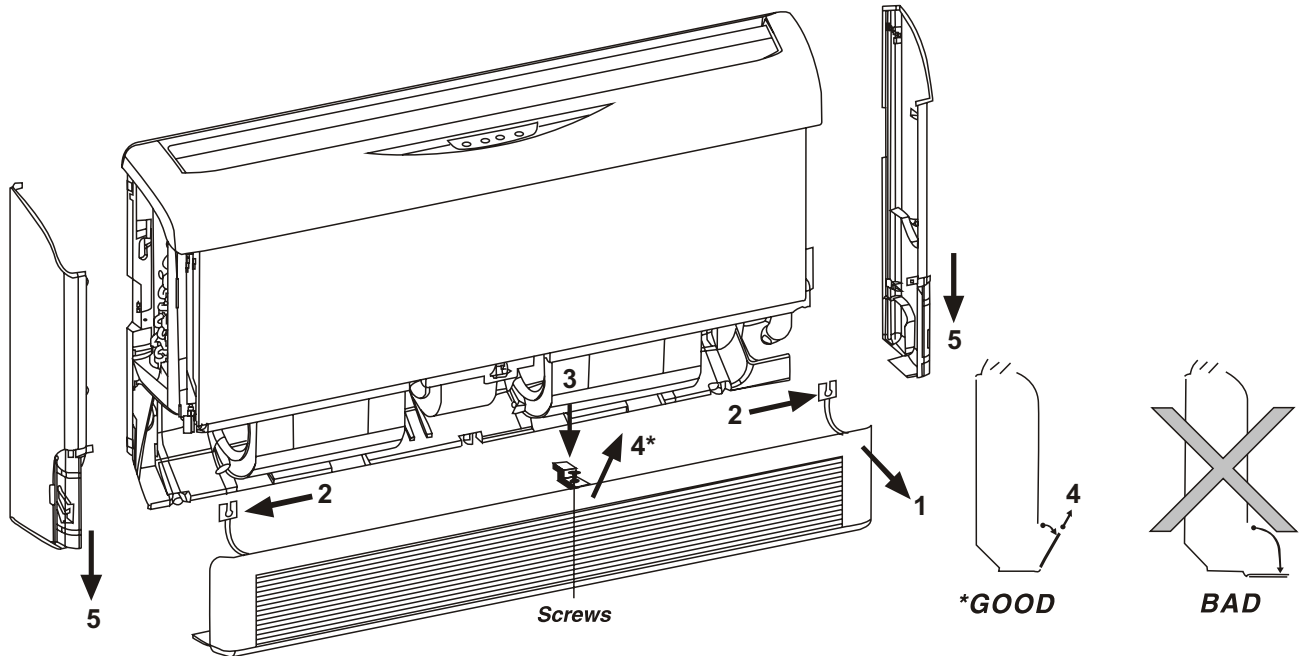
**FOR THE AIR INLET GRILL:**

- 1 Pull the gril forwards.
- 2 Remove the two end screws.
- 3 Unscrew the central screw, but do not remove it completely.
- 4 Unhook the grid.

**FOR THE SIDE PANELS:**

- 5 Remove the side panels (downward movement)



## INSTALLATION OF THE PXD ON THE WALL SUPPORT

- Refer to the diagram below, for installation of the PXD.
- Ceiling mounting (referto the NOTE below).

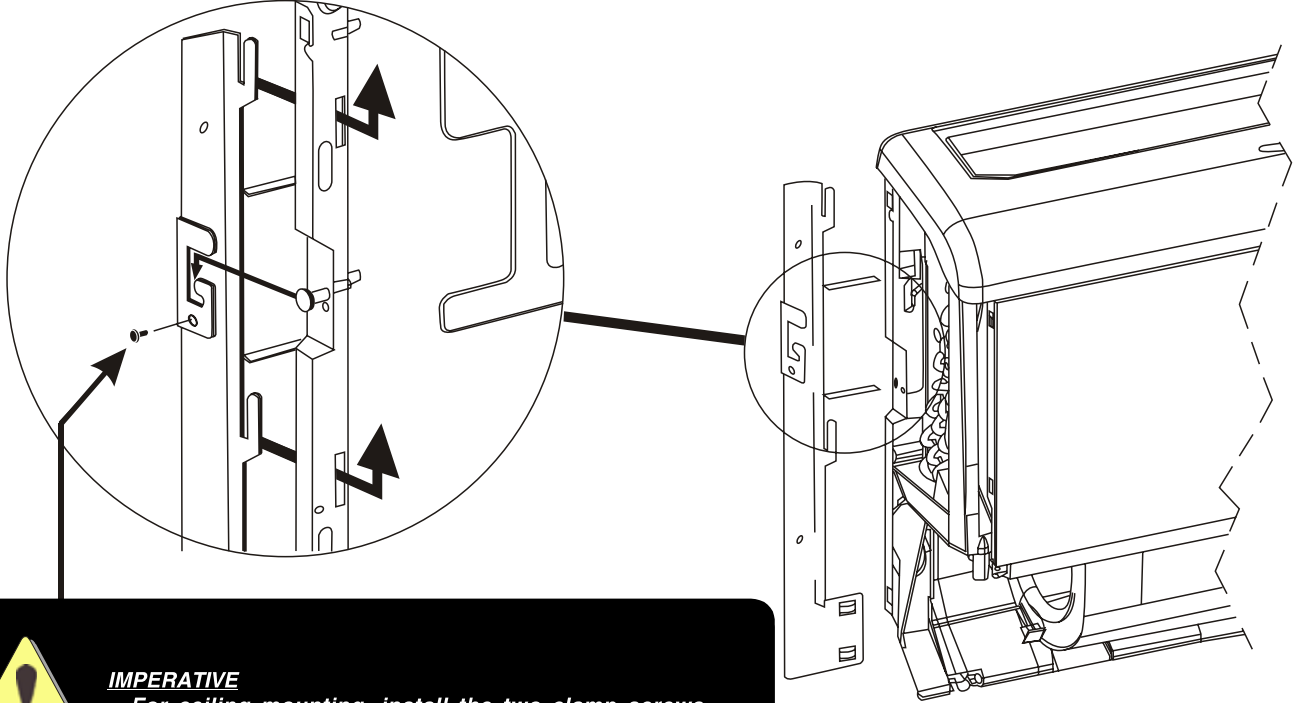

**IMPERATIVE**

- For ceiling mounting, install the two clamp screws (provided) for the unit on the support.

wall mounted



ceiling mounted

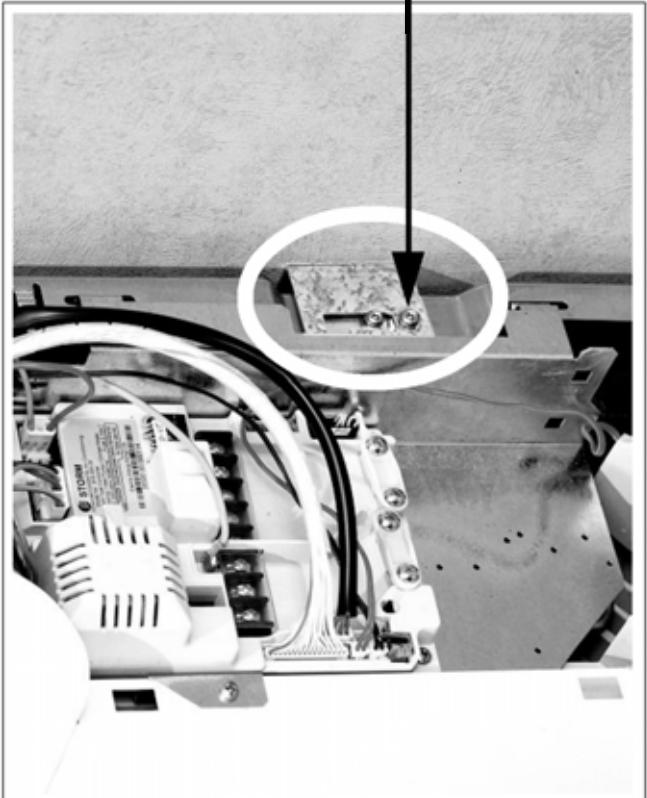

## CONNECTION OF CONDENSATE EVACUATION TUBE

- Water condensation must be evacuated directly to the outside; observe an appropriate slope for the evacuation duct, which should slope downwards in the case of a connection to the wastewater system (2.5 cm/m slope).
- An S-bend must be installed on the evacuation duct, below the level of the recovery tray of the unit.
- Provide insulation for the evacuation tube in the case of a risk of freezing or condensation.
- Evacuation with pump kit: (refer to instructions provided with kit).
- The unit is supplied with an evacuation tube.
- The right and left outlets are blocked off by a plug. Do not forget to remove this plug before connecting the evacuation tube.

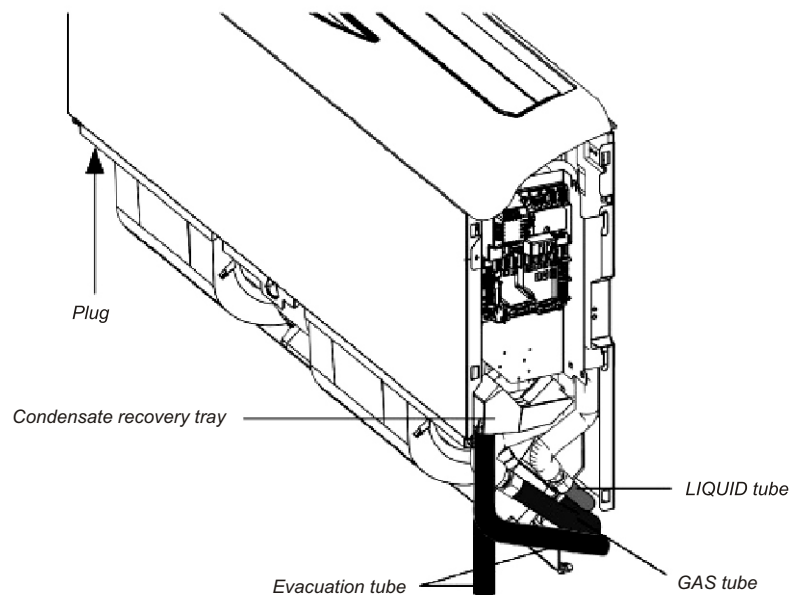

- In the case of a ceiling mounted installation, run the evacuation tube down along the side panel and secure it with clamps as shown below. Also break the preformed cut-out in the corner of the intake grid.

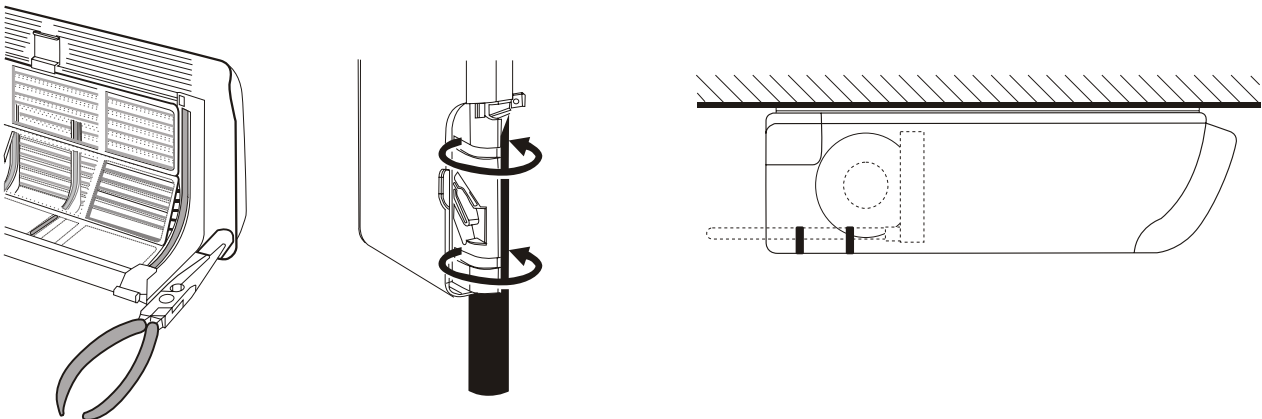



**VACUUM OF COOLING PIPES AND INDOOR UNIT**

- Only the outdoor unit is charged with R410A cooling fluid. The indoor unit contains a small quantity of a neutral gas. This the reason it is imperative to vacuum the linking pipes and the indoor unit.

**ASSEMBLY**

- The outdoor unit is equipped with a valve allowing to vacuum the installation (large valve)
- 1 Connect the connecting pipes to the outdoor unit by **FLARE NUTS** and to the indoor unit by **BRAZING**
- To obtain the right tightening, cover the sur face with cooling oil.

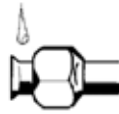

- The use of a counter wrench is required to tighten the valves.



- The values of the tightening torque are shown in the table below.

<b>Ø of the Pipe</b>	<b>Torque</b>
Pipe 1/4"	15-20 Nm
Pipe 3/8"	30-35 Nm
Pipe 1/2"	50-54 Nm
Pipe 5/8"	70- 75 Nm
Pipe 7/8"	90-95 Nm

- 2 Connect the vacuum pump with the flare coupling of the outdoor unit equipped with a process valve.
- 3 Start the vacuum pump and check that the needle of the indicator goes down to - 0,2 mm Hg.  
The pump should run during at least 15 minutes.
- 4 Before disconnecting the vacuum pump, check that the vacuum indicator remains in the same position during five minutes.
- 5 Disconnect the vacuum pump.
- 6 Remove the cap of the "GAS" and "LIQUID" valves and open them with a hexagonal wrench to free the R410A contained in the outdoor unit.
- 7 Check that the linking pipes are sealed. Use an electronic leak detector or a soapy sponge.

**ELECTRICAL CONNECTION BETWEEN INDOOR AND OUTDOOR UNIT**

**ELECTRICAL REQUIREMENTS**

Electrical wiring and connections should be made by qualified electricians and in accordance with local electrical codes and regulation. The air conditioner units must be grounded.

The air conditioner unit must be connected to an adequate power outlet from a separate branch circuit protected by a time delay circuit breaker, as specified on unit's nameplate.

Voltage should not vary beyond 10% of the rated voltage.

An all-pole disconnection switch having a contact separation of at least 3mm in all poles should be connected in fixed wiring.

1. To connect the indoor unit to the outdoor unit use the following electrical cables.

**Electrical connections:**

Capacity	12000 Btu (3500 W) model	18000 Btu (5000 W) model 24000 Btu (7200 W) model
Power input cable	3 wires × 1.5mm <sup>2</sup>	3 wires × 2.5mm <sup>2</sup>
Cable between indoor and outdoor unit	4 wires × 1.5mm <sup>2</sup>	4 wires × 2.5mm <sup>2</sup>

2. Prepare the needed cables for electrical connection.
3. Connect the cable ends to the terminals of the indoor and outdoor units.
4. Secure the multiple wire power cable with the cable clamps.

**NOTES:** The wire color code can be selected by the installer.  
The temperature of refrigerant circuit will be high, please keep the interconnection cable away from the copper tube.

• Cable between indoor and outdoor units

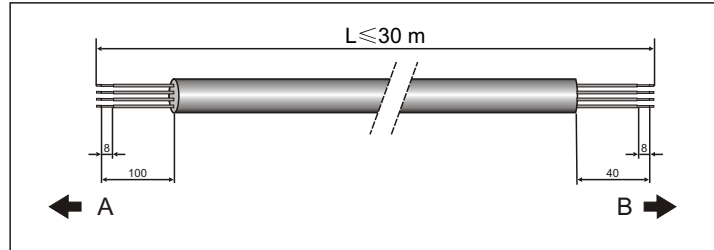

A. OUTDOOR B. INDOOR

**Power supply from indoor unit**

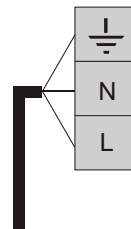
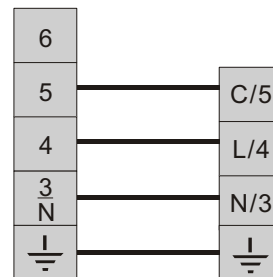

**Power supply from outdoor unit**

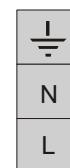
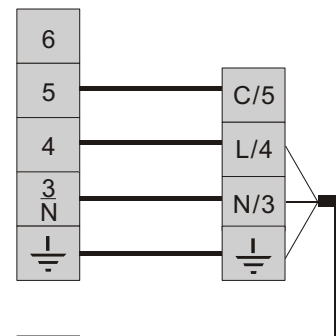

**INDOOR      OUTDOOR**

### Display control unit

It is recommended to install the Display Control Unit close to a ceiling in a central and neutral zone at typical conditions. In addition, the aesthetic aspect should be considered. The Display Control Unit is connected to the main control board on the air conditioner (the indoor unit) by a communication cable. The cable is connected to the Display Control Unit by a quick-connector. (8 pin plug)

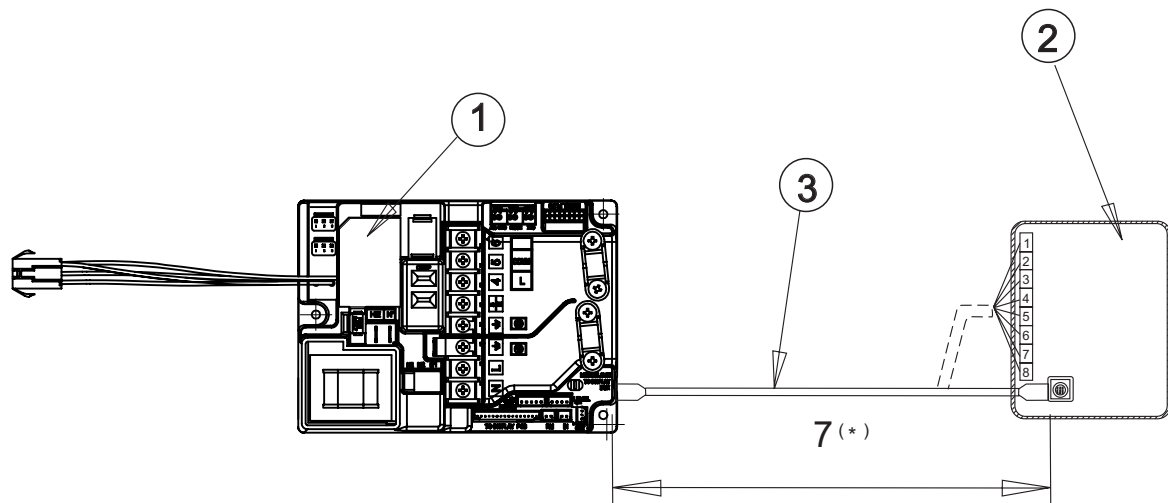

1. Main Control Board on Indoor Unit
2. Control Display Unit
3. Connection Wire

COLOR CHART	
Conn. Point	Wire Color
1	Gold
2	Orange
3	Yellow
4	Brown
5	Green
6	White
7	Grey
8	Red

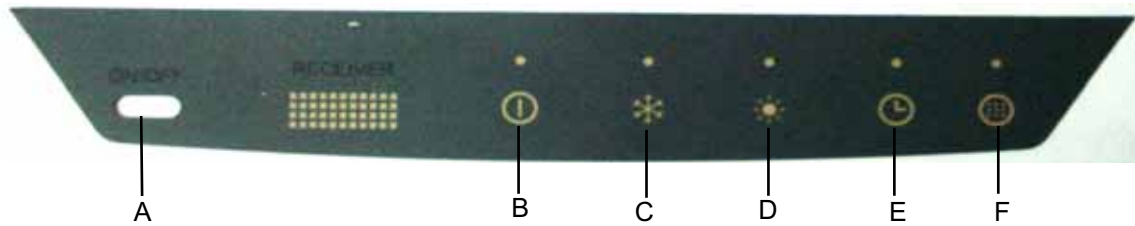
**INDICATOR LIGHTS AND CONTROLS ON THE UNIT****A) ON/OFF**

*Press the button to turn ON/OFF the unit.*

**B) POWER INDICATOR**

*Lights as the unit is energised.*

**C) COOLING INDICATOR**

*Lights up only when button(A) is pressed.*

*Cooling, humidifying and filtering the air in the room. Keeping the required ambient temperature.*

**D) HEATING INDICATOR**

*Lights up only when button(A) is pressed.*

*Heating and filtering the air in the room. Keeping the required ambient temperature.*

**E) TIME AND PROGRAMMING INDICATOR**

● **TIME:** Yellow LED, function as units today with RIC control.

● **PROGRAMMING:** Lights during operation. Flashes to indicate that the remote control signal has been received and stored in the memory in RCW control.

**F) FILTER INDICATOR**

*Lights when the air filter needs cleaning. After cleaning and re-installing the filter system must be reset (RESET button).*

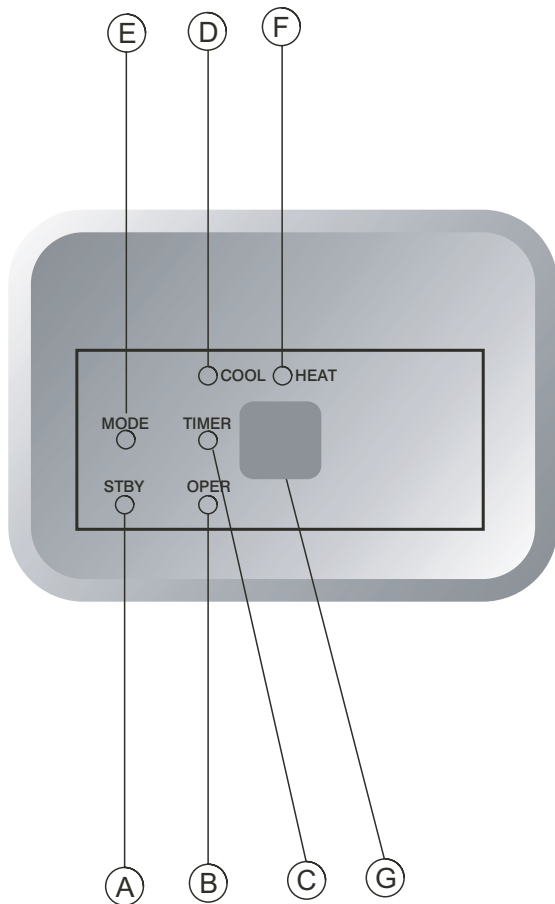
**CENTRAL CONTROL DISPLAY PANEL****A. STAND-BY INDICATOR**

Lights up when the air conditioner is connected to power and ready to receive the remote control commands.

**B. OPERATION INDICATOR**

Lights up during operation. Blinks to announce that the remote control infrared signal has been received and stored.

**C. TIMER INDICATOR**

Lights up during TIMER and SLEEP operation.

**D. COOLING INDICATOR**

Lights up only when button(E) is pressed.

**E. MODE - COOL/HEAT/ON/OFF - UNIT**

OPERATION BUTTON

Used to switch the unit to positions: OFF, ON, COOLING or HEATING without the use of the remote control. The button can be activated by a plastic rod or splinter.

**F. HEATING INDICATOR**

Lights up only when button(E) is pressed.

**G. SIGNAL RECEIVER**

Receives IR signals from the remote control.

**ACTIVE CHARCOAL FILTER**

- An active charcoal filter and its support are supplied as accessories with your product. (1 per filter)
- in order to optimise air filtration, you can install it as follows.

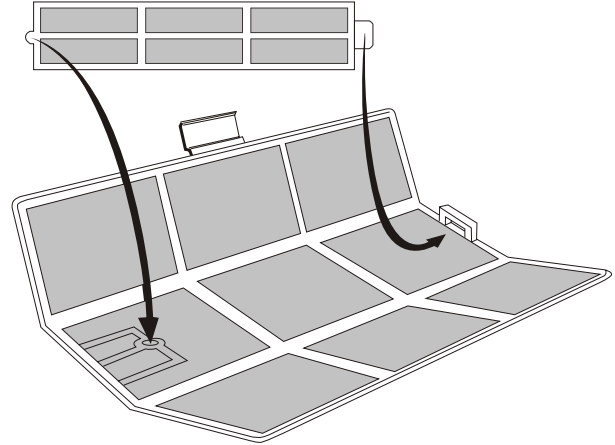
**MAINTENANCE AND REPAIR**

**BEFORE UNDERTAKING MAINTENANCE OPERATIONS, MAKE SURE THAT THE AIR CONDITIONER IS DISCONNECTED FROM THE MAINS.**

**Cleaning of air filter**

Your air conditioner has an air filter clogging indicator light. When this indicator light F comes on, the filter must be cleaned.

- To remove the filter, pull the inlet grid forward and press the filters slightly downwards to unclip them.
- Reset the unit by pressing the Reset button. The filter indicator light F goes out.

**Do not operate the air conditioner without the filter !****Cleaning of the air conditioner**

- Rub the inside of the unit with a soft, dry cloth.
- Do not use hot water or volatile detergents, which could damage the face of the air conditioner.

**Precautions to be taken**

- Check that there are no obstacles preventing the flow of inlet air and pulsed air, on both the indoor and outdoor units.
- Check that the air conditioner is correctly connected.

**Protection of the electronic system**

- The indoor unit and the remote control must not be located less than one metre from a television set, a radio or any other electrical appliance, in order to avoid interference.
- Protect the unit against direct sunlight.

**Replacement of the remote control batteries**

- Remove the batteries from the remote control unit via the rear flap.
- Fit two new 1.5 V type **AAA** dry cell batteries.
- Used batteries must be recycled.

## **SERVICING**

### **Routine servicing**

- To ensure the correct operation of the installation, it is necessary to have preventive maintenance of the indoor and outdoor units carried out by qualified personnel.

### **General installation**

- Carry out a visual inspection of the complete installation in service.
- Check the general cleanness of the installation, and check that the condensate evacuations are not blocked, particularly on the indoor unit, before the summer season.
- Check the condition of the tray.

## **OUTDOOR UNIT**

### **Coolant system**

- Clean the heat exchanger using a special product for aluminium-copper heat exchangers, and rinse with water. Do not use hot water or steam, as this could cause the pressure of the coolant to increase.
- Check that the surface of the aluminium fins of the heat exchanger is not damaged by impacts or scratches, and clean with an appropriate tool if necessary.

### **Electrical section**

- Check that the main power supply cable is not damaged or altered in such a way as to affect the insulation.
- Check that the interconnecting cables between the two units are not damaged or altered, and that they are correctly connected.
- Check the earth connection.

## **INDOOR UNIT**

- In order for the installation to operate correctly, it is essential to regularly clean the air filter located in the intake of the indoor unit.
- When clogged, the filter reduces the air flow through the heat exchanger of the indoor unit, which in turn reduces the efficiency of the installation and inhibits the cooling of the fan motor.
- Check the cleanness of the indoor heat exchanger.

## **CAUTION**

**BEFORE CARRYING OUT ANY OPERATION ON THE EQUIPMENT, CHECK THAT THE ELECTRICAL POWER SUPPLY IS SWITCHED OFF AND THAT IT CANNOT BE SWITCHED ON INADVERTENTLY.**

