

FRANÇAIS CLIMATISEUR CENTRALISÉ - SYSTÈME SPLIT AVEC
 CONTRÔLE ÉLECTRONIQUE - SÉRIE DLS

ENGLISH CENTRAL AIR CONDITIONER WITH ELECTRONIC CONTROL
 SPLIT SYSTEM: SERIES DLS

DEUTSCH ZENTRAKLIMAANLAGE - SPLITSYSTEM MIT
 ELEKTRONISCHER KONTROLLE - SERIE DLS

ESPAÑOL ACONDICIONADOR DE AIRE CENTRAL DEL TIPO "SPLIT"
 CONTROL ELECTRÓNICO - SERIE DLS

ITALIANO CONDIZIONATORE D'ARIA CENTRALIZZATO SISTEMA
 SPLIT A CONTROLLO ELETTRONICO - SERIE DLS

РУССКИЙ ДОМАШНЯЯ СПЛИТ-СИСТЕМА КОНДИЦИОНЕРА ВОЗДУХА
 С ЭЛЕКТРОННЫМ УПРАВЛЕНИЕМ - СЕРИЯ DLS

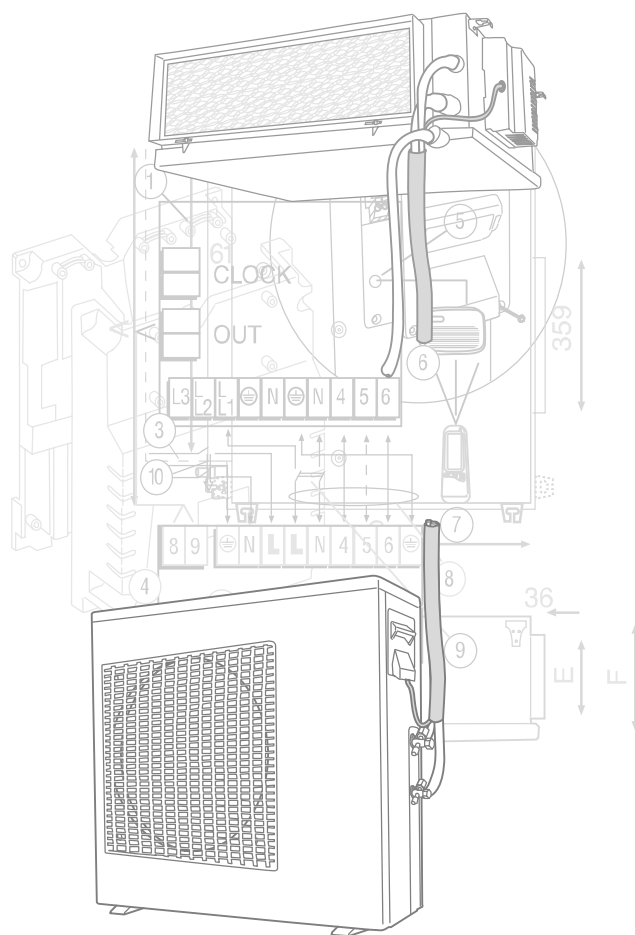

INSTRUCTIONS DE MONTAGE
INSTALLATION INSTRUCTIONS
AUFSTELLUNGSANLEITUNG
INSTRUCCIONES DE INSTALACIÓN
MANUALE PER L'INSTALLAZIONE
РУКОВОДСТВО ПО УСТАНОВКЕ

Airwell

CENTRAL AIR CONDITIONER WITH ELECTRONIC CONTROL

SPLIT SYSTEM SERIES DLS

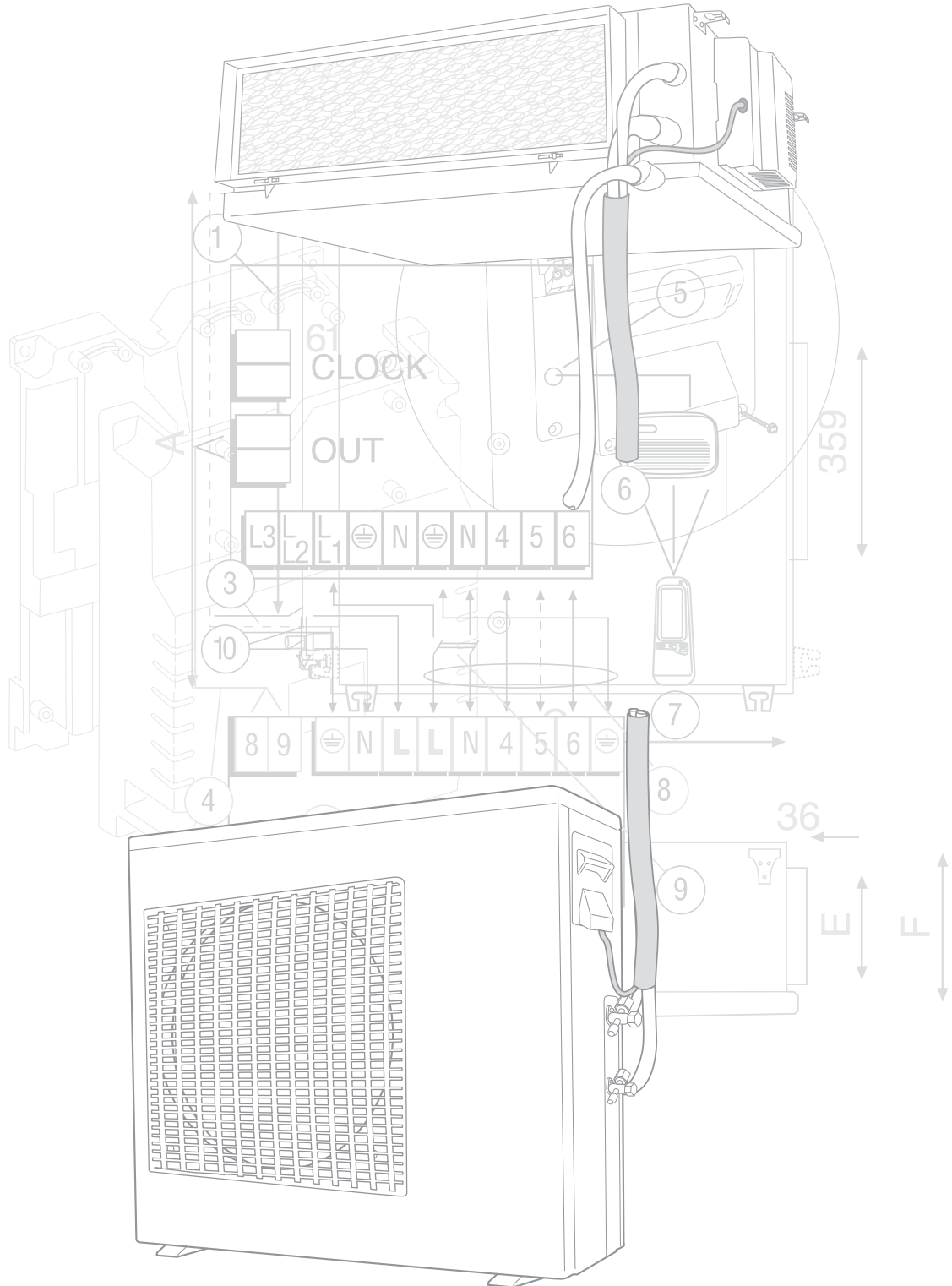

INSTALLATION INSTRUCTIONS

Getting started...

REQUIRED TOOLS LIST

- | | | |
|---|------------------------------------|--------------------|
| 1. Screw driver | 8. Gas leak detector | 15. Torque wrench |
| 2. Electric drill,
hole core drill (60 mm) | 9. Measuring tape | 18 N m (1.8 kgf.m) |
| 3. Hexagonal wrench | 10. Thermometer | 45 N m (4.5 kgf.m) |
| 4. Spanner | 11. Megameter | 65 N m (6.5 kgf.m) |
| 5. Pipe cutter | 12. Multimeter | 75 N m (7.5 kgf.m) |
| 6. Reamer | 13. Vacuum pump | 85 N m (8.5 kgf.m) |
| 7. Knife | 14. Gauge manifold
(for R-410A) | |

SAFETY PRECAUTIONS

Read the following "SAFETY PRECAUTIONS" carefully before installation. Electrical work must be installed by a licensed electrician. Be sure to use the correct rating of the power plug and main circuit for the model to be installed.

The caution items stated here must be followed because these important contents are related to safety. The meaning of each indication used is as below. Incorrect installation due to ignoring of the instruction will cause harm or damage, and the seriousness is classified by the following indications.

WARNING

- Use qualified installer and follow careful this instructions, otherwise it will cause electrical shock, water leakage, or aesthetic problem.
- Install at a strong and firm location which is able to withstand the set's weight. If the strength is not enough or installation is not properly done, the set will drop and cause injury.
- For electrical work, follow the local national wiring standard, regulation and this installation instruction. An independent circuit and single outlet must be used. If electrical circuit capacity is not enough it will cause electrical shock or fire.
- Use the specified cable and connect tightly for indoor/outdoor connection. Connect tightly and clamp the cable so that no external force will be acted on the terminal.
If connection or fixing is not perfect, it will cause heat-up or fire at the connection.
- Wire routing must be properly arranged so that control board cover is fixed properly. If control board cover is not fixed perfectly, it will cause heat-up at connection point of terminal, fire or electrical shock.

ATTENTION

- Selection of the units location.
Select a location which is rigid and strong enough to support or hold the unit, and select a location for easy maintenance.
- Do not release refrigerant during piping work for installation, reinstallation and during repairing a refrigeration parts. Take care of the liquid refrigerant, it may cause frostbite.
- Installation work. It may need two people to carry out the installation work.
- Do not install this appliance in a laundry room or other location where water may drip from the ceiling, etc.

Carry out test running to confirm that no abnormality occurs after the installation. Then, explain to user the operation, care and maintenance as stated in instructions. Please remind the customer to keep the operating instructions for future reference.

The items to be followed are classified by the symbols:





WARNING

This indication shows the possibility of causing death or serious injury.



Symbol with background white denotes item that is PROHIBITED from doing.

- When carrying out piping connection, take care not to let air substances other than the specified refrigerant go into refrigeration cycle, otherwise, it will cause lower capacity, abnormal high pressure in the refrigeration cycle, explosion and injury.
- Do not damage or use unspecified power supply cord. Otherwise, it will cause fire or electrical shock. 
- Do not modify the length of the power supply cord or use of the extension cord, and do not share the single outlet with other electrical appliances. Otherwise, it will cause fire or electrical shock. 
- This equipment must be earthed. It may cause electrical shock if grounding is not perfect. 
- Do not install the unit at place where leakage of flammable gas may occur. In case of gas leaks and accumulates at surrounding of the unit, it may cause fire.
- Carry out drainage piping as mentioned in installation instructions. If drainage is not perfect, water may enter the room and damage the furniture.





Contents:

Installation/Service Tooling	3
Attached Accesories	
General information	4
General precautions	5
Indoor unit	6
Access to the unit	
Unit Installation	
Drainage installtion	7
Air filter access	
Outdoor unit	8
unit dimention	
Several outdoor installtion	
Disposel of outdoor unit drain water	

Pipes connections	9
Cutting and flaring	
Pipe isulation	
Pipe connectors to unit	
Evacuation of pipes and indoor unit	
Electrical connections	10
Display Control Unit	11
Check list before operation	12
Air volume/static pressure table	

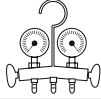
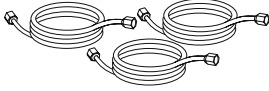
Installation/Service Tooling for R410A

Changes

Gauge manifold		As the working pressure is high, it is impossible to measure the working pressure using conventional gauges. In order to prevent any other refrigerant from being charged, the port diameters have been changed.
Charge hose		In order to increase pressure resisting strength, hose materials and port sizes have been changed (to 1/2 UNF 20 threads per inch). When purchasing a charge hose, be sure to confirm the port size.
Electronic scale for refrigerant charging		As working pressure is high and gasification speed is fast, it is difficult to read the indicated value by means of charging cylinder, as air bubbles occur.
Torque wrench (nominal dia. 1/2, 5/8)		The size of opposing flare nuts have been increased. Incidentally, a common wrench is used for nominal diameters 1/4 and 3/8.
Flare tool (clutch type)		By increasing the clamp bar's receiving hole size, strength of spring in the tool has been improved.
Gauge for projection adjustment		Used when flare is made by conventional flare tool.
Vacuum pump adapter & check valve		Connected to a conventional vacuum pump. It is necessary to use an adapter to prevent vacuum pump oil from flowing back into the charge hose. The charge hose connecting part has two ports -- one for conventional refrigerant (7/16 UNF 20 threads per inch) and one for R410A. If the vacuum pump oil (mineral) mixes with R410A a sludge may occur and damage the equipment.
Gas leakage detector		Exclusive for HFC refrigerant.

Incidentally, the "refrigerant cylinder" comes with the refrigerant designation (R410A) and protector coating in the U.S.'s ARI specified rose colour (ARI colour code: PMS 507). Also, the "charge port and packing for refrigerant cylinder" requires 1/2 UNF 20 threads per inch corresponding to the charge hose's port size.

CAUTION R410A Air Conditioner Installation

THIS AIR CONDITIONER ADOPTS THE NEW HFC REFRIGERANT (R410A) WHICH DOES NOT DESTROY OZONE LAYER. R410A refrigerant is apt to be affected by impurities such as water, oxidizing membrane, and oils because the working pressure of R410A refrigerant is approx. 1.6 times of refrigerant R22. Accompanied with the adoption of the new refrigerant, the refrigeration machine oil has also been changed. Therefore, during installation work, be sure that water, dust, former refrigerant, or refrigeration machine oil does not enter into the new type refrigerant R410A air conditioner circuit. To prevent mixing of refrigerant or refrigerating machine oil, the sizes of connecting sections of charging port on main unit and installation tools are different from those used for the conventional refrigerant units. Accordingly, special tools are required for the new refrigerant (R410A) units. For connecting pipes, use new and clean piping materials with high pressure fittings made for R410A only.

Moreover, do not use the existing piping because there are some problems with pressure fittings and possible impurities in existing piping.

Changes in the product and components











In air conditioners using R410A, in order to prevent any other refrigerant from being accidentally charged, the service port diameter size of the outdoor unit control valve (3 way valve) has been changed. (1/2 UNF 20 threads per inch).

In order to increase the pressure resisting strength of the refrigerant piping, flare processing diameter and opposing flare nuts sizes have been changed. (for copper pipes with nominal dimensions 1/2 and 5/8).

In case of pipes welding please make sure to use dry Nitrogen inside the pipes.

Use copper tube of special thickness for R410A: 1/4"-1/2" 0.8 mm
5/8"-3/4" 1 mm
7/8" 1.1 mm

ATTACHED ACESORIES

Description	Amount	Name	USE
	1	Technician's installation manual	Installation instructions
	1	Instruction manual for remote control	Operation instructions for remote
	1	Instruction manual for unit display	Operation instructions
	1	Remote control including batteries	Operating the air-conditioner
	1	Remote control bracket	Hanging the remote control on the wall
	1	Central control display	Operating and main working display
	4	Rubber mounting pads	Padding of the outdoor unit
	4	Tie - Wraps	Tightening the indoor and the outdoor units electrical cables
	4each	Dibbles - Screws - Washers	Installing bracket for remote control and central control display
	1	Drain elbow	Connecting drain hose to outdoor

GENERAL INFORMATION

Indoor Unit

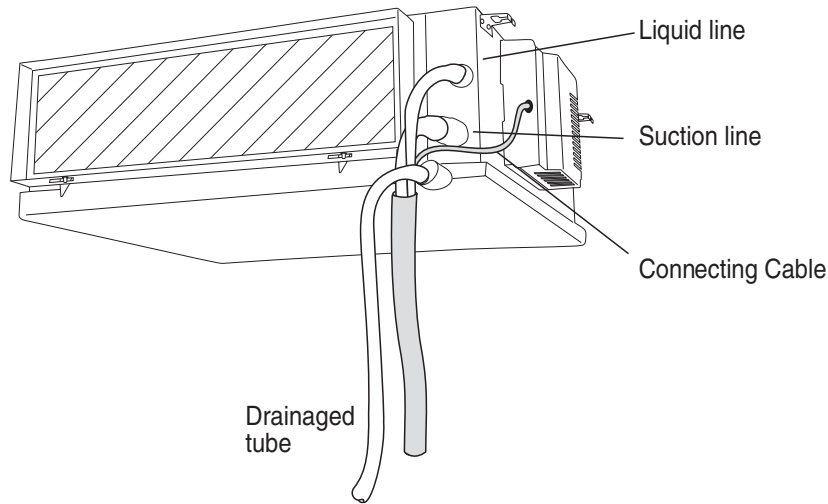

Outdoor Unit

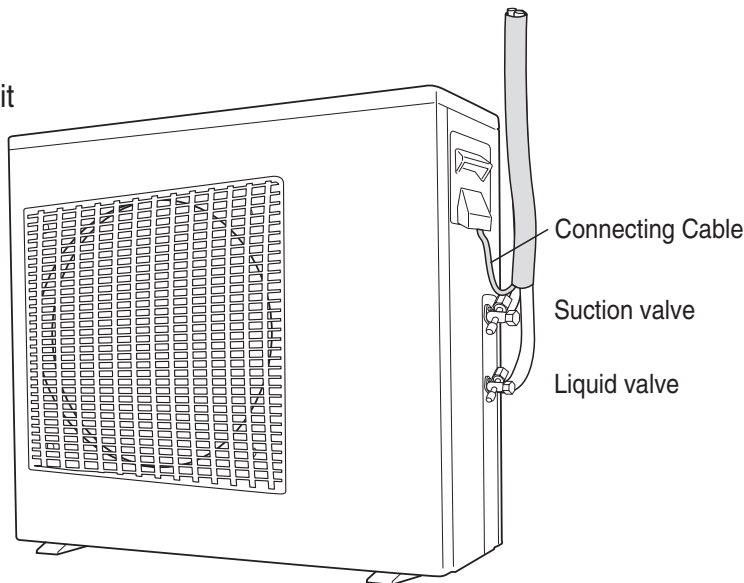

MAXIMUM PIPES LENGTH & HEIGHT

CAP.	TUBES O.D	LENGTH (A)	HEIGHT (B)
5kw	1/4"-1/2"	30/50*	15/25*
7kw	3/8"-5/8"	30/50*	15/25*
9kw	3/8"-5/8"	50	25
10.5kw	3/8"-3/4"	50	25
12.5kw	3/8"-3/4"	50	25
14kw	3/8"-3/4"	50	25
16kw	1/2"-7/8"	50	25

*Special Order

EXTERNAL STATIC PRESSURE

CAP.	NOMINAL	MIN-MAX
5kw	25	25-60
7kw	25	25-60
9kw	37	37-80
10.5kw	37	37-100
12.5kw	50	50-100
14kw	50	50-100
16kw	50	50-120

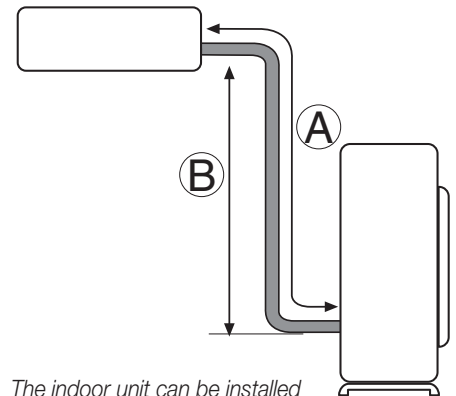

The indoor unit can be installed also below the outdoor unit.

GENERAL PRECAUTIONS

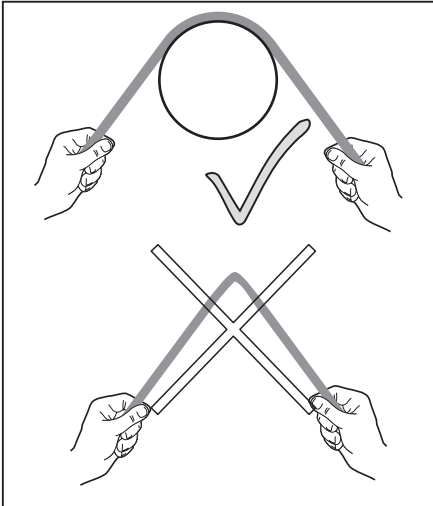

Always use the support of a large radius cylinder for banding the tubes, using pipe bending tools

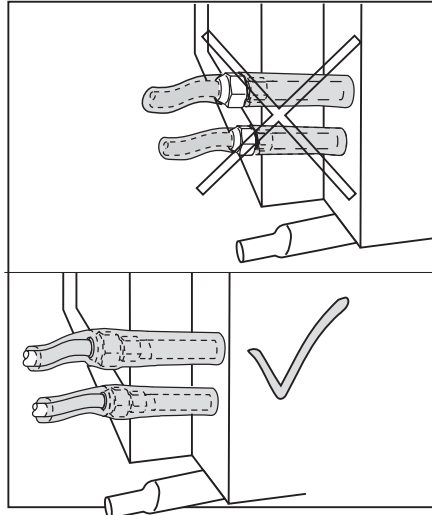

Do not leave nuts of gas tubes uncovered

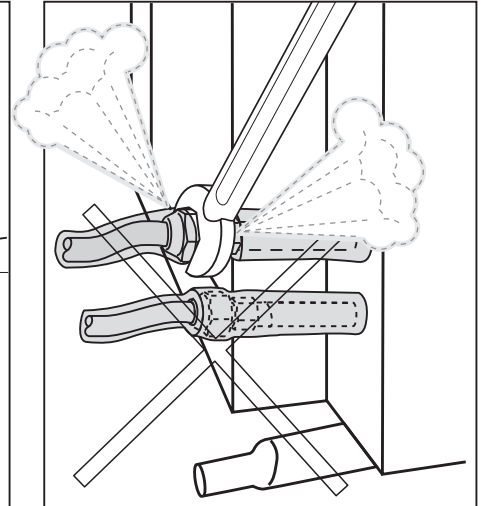

Do not untie gas tubes after installation

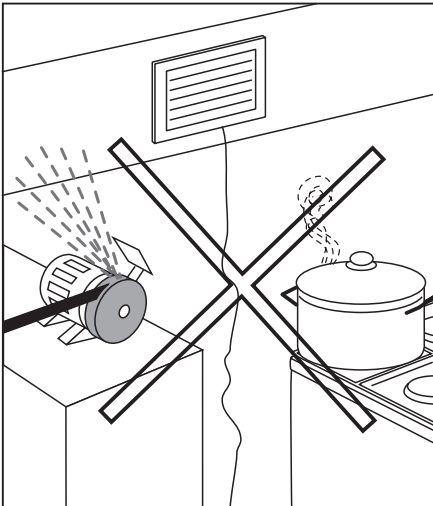

Avoid placing the indoor unit near water or oily mist.

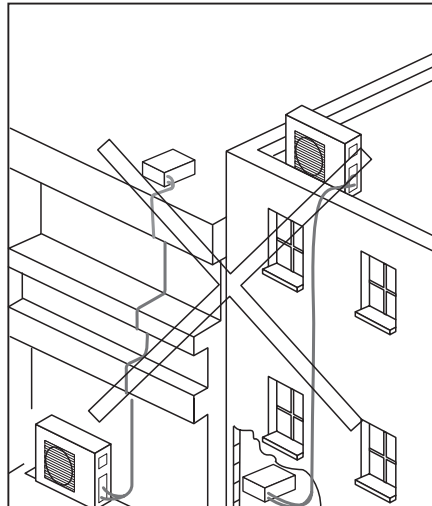

Avoid pipes bending and keep pipes as short as possible.

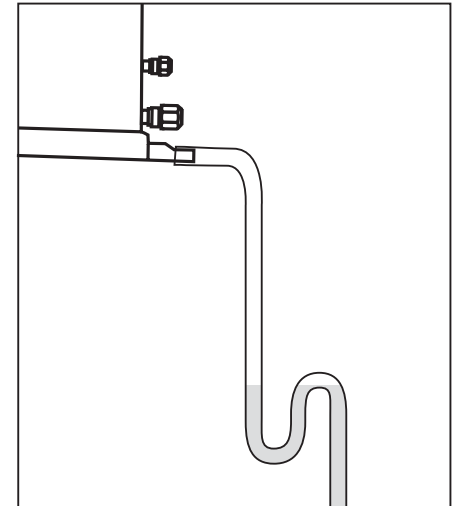

Making of a water trap (Siphon) will prevent bad odors and assure proper drainage.

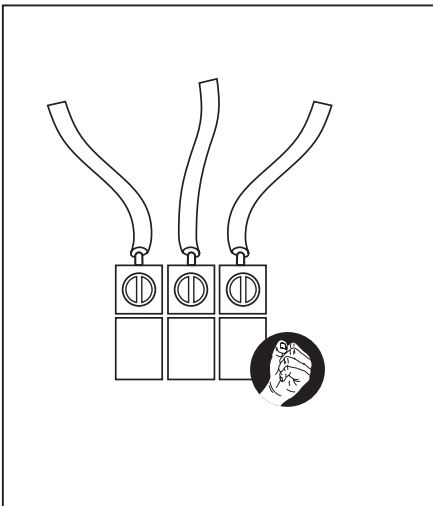

Tighten electrical circuits cables

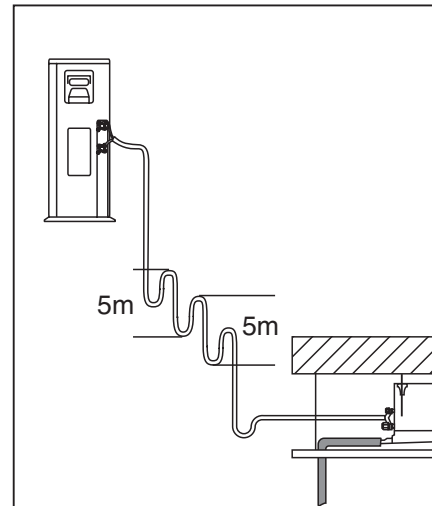

Oil trap for units up to 5Kw. In case the outdoor unit is under the indoor unit no trap is required

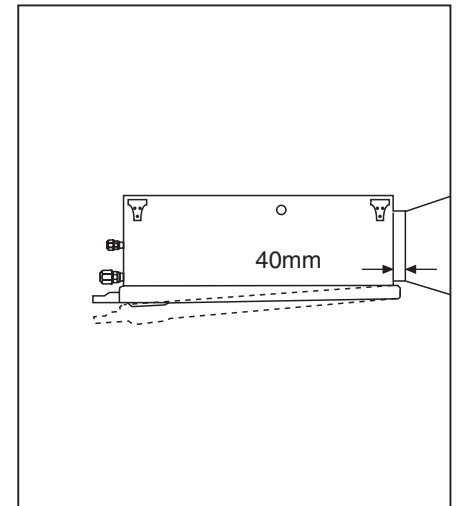

Keep 40 mm distance between duct plenum and the unit for easy drain removal.

INDOOR UNIT

UNIT LOCATION

- While selecting a place for the indoor unit:
- Allow max. air flow to the desired space
 - Allow max return air flow
 - Ensure adequate drainage of condensed water
 - Ensure noise reduction near bedrooms
 - Leave a minimum 250 mm free space in front of the filter
 - Allow a free service access to electrical box.
 - Allow easy access to the base of the indoor unit while providing enough space from the ceiling
 - Use serrated rubber under the unit and flexible joints to avoid resonance vibrations

CAP.	A	B	C	D	E	F
5-9 Kw	790	653	749	256	162	242
10-13 Kw	854	715	816	297	193	282
14-16 Kw	854	715	816	337	233	322

UNIT DIMENTIONS

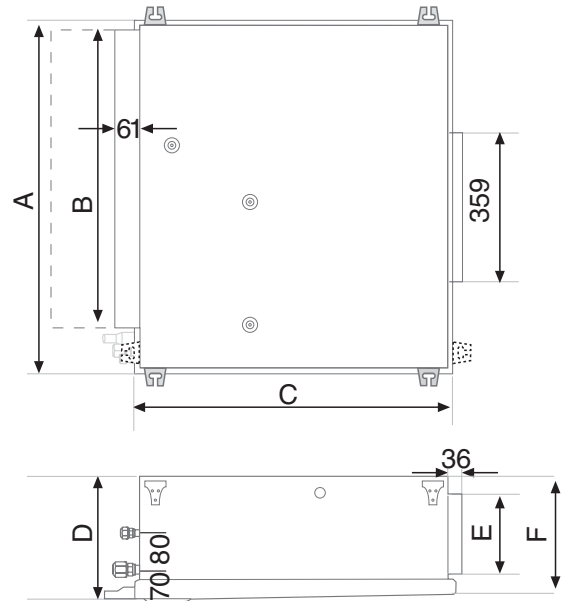

ACCESS TO THE UNIT

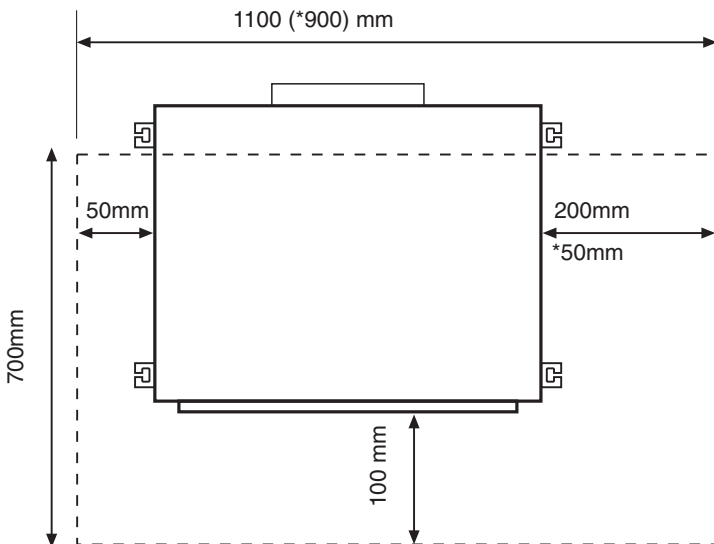

* In case control box is dismantled from the unit

CLEARNS AROUND THE UNIT

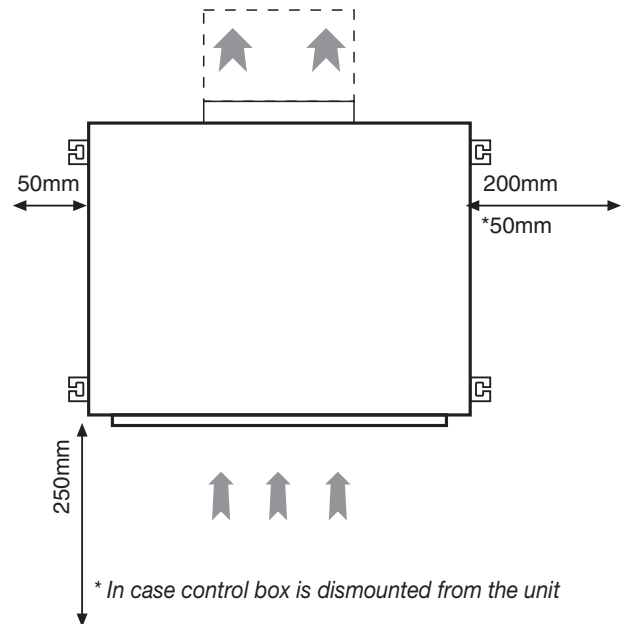

* In case control box is dismantled from the unit

UNIT INSTALLATION

- Insert 4 M10 or 3/8" threads rods into the ceiling.
- Introduce the rodes through the slots of unit suspension brackets.
- Position the shock absorbers, add washers and screw the nuts until the unit is firmly supported.
- In case of a gap between the unit and the ceiling, put a rubber or a neoprene sheet.

IMPORTANT The unit must be perfectly levelled

HOLES DRILLING LOCATION ON THE CEILING FOR INDOOR UNIT

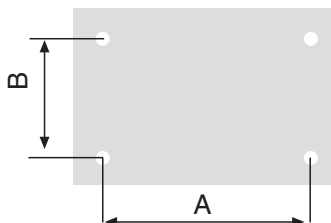

CAP.	A	B
5-9 Kw	797	599
10-16 Kw	861	663

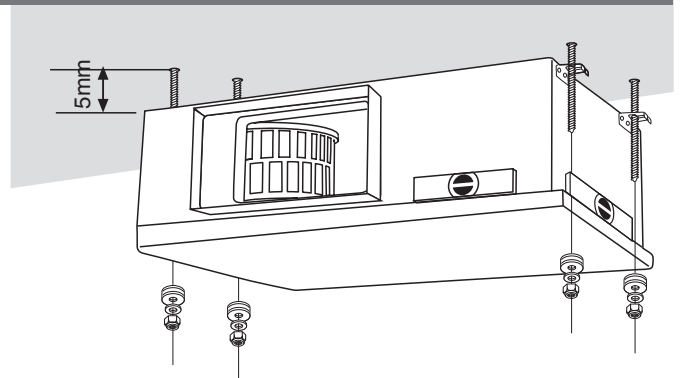

DRAINAGE INSTALLATION

For an efficient functioning of the drainage system please take care of the following:

- Since the drainage basin bottom is sloppy, Alwaysways balance the unit by the suspension brackets and not by the drainage basin itself.
- Always lay the drain with downward inclination 2%.
Prevent any upward flow or reverse flow in any part.
- Use 19 mm tube for drainage.

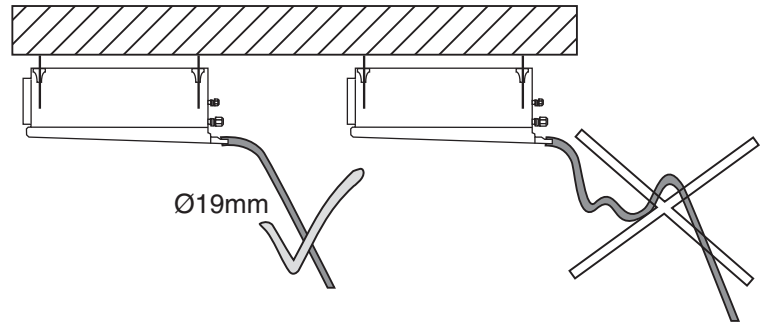
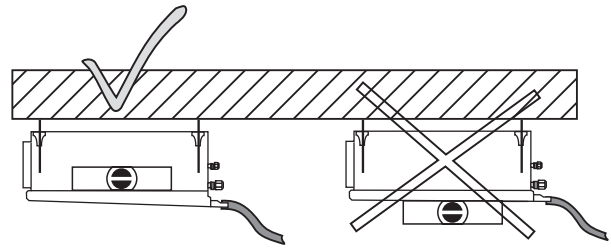

AIR FILTER ACCESS

ACCESS FROM BACK OF UNIT

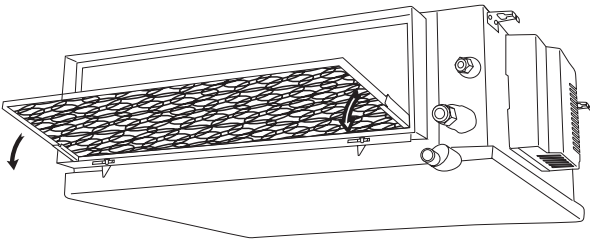

Pull the eyelets in both sides of the filter till the filter is in horizontal position.

Pull the air filter for further treatment.

ACCESS FROM BOTTOM OF UNIT (For return air duct application)

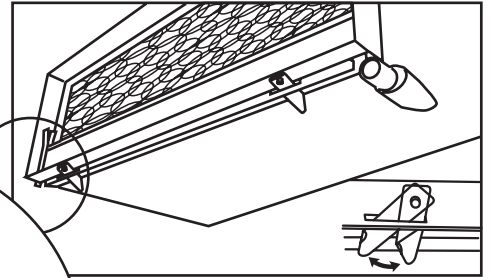

For first time use: Straighten the shim as shown in figure

Release the locking clip

Pull down the air filter for further treatment

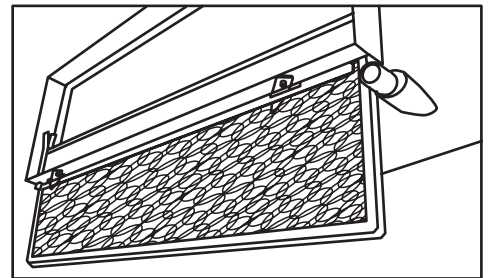
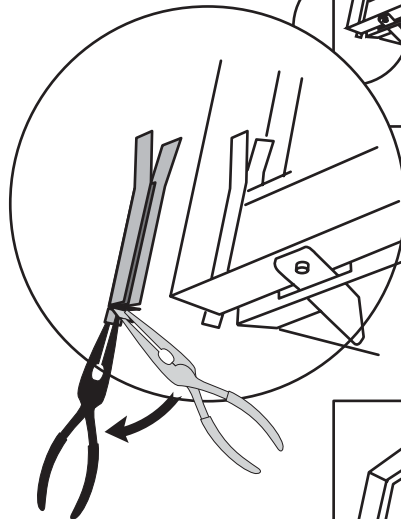

OUTDOOR UNIT

UNIT DIMENSIONS

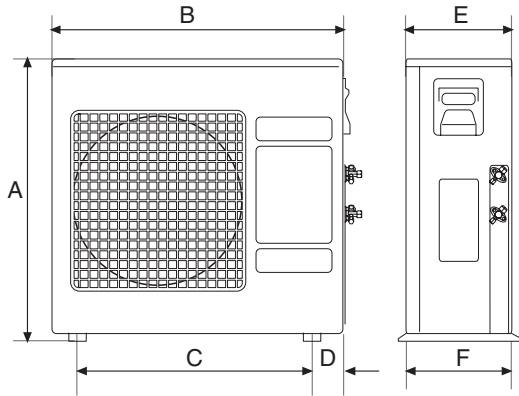

CAP.	A	B	C	D	E	F
5 Kw	610	795	500	148	290	293
6 Kw	680	900	705	97	340	357
9 Kw	860	900	705	97	340	357
10-13 Kw	970	900	705	97	340	357
14-16 Kw	1250	900	705	97	340	357

CLEARANCES AROUND THE UNIT

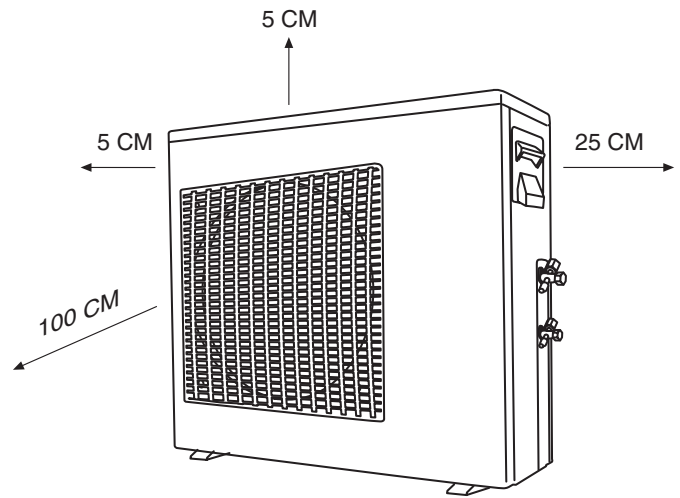

SEVERAL OUTDOORS INSTALATION

When installing several outdoors units please take into account the air flow around the units and follow the minimum distance suggestions as shown in the diagrams below.

Row Installation

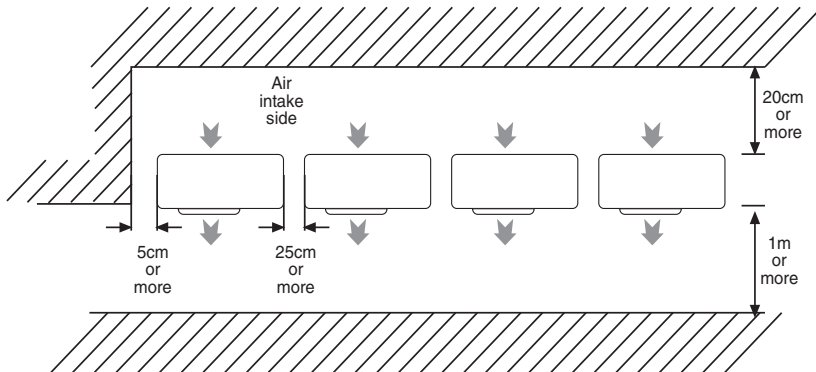

Back to Back Front to Front

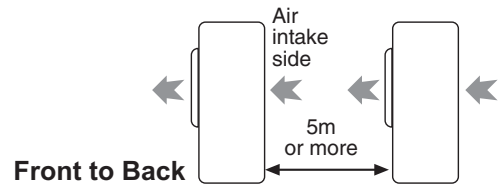
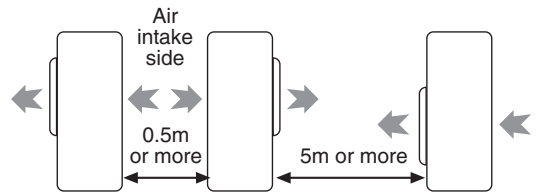

DISPOSAL OF OUTDOOR UNIT DRAIN WATER

In case of using a drain elbow, the unit should be placed on a stand at least 3 cm high.

Install the hose with a downward to allow smooth flow of draining water.

Use 16mm I.D. tube for drainage.

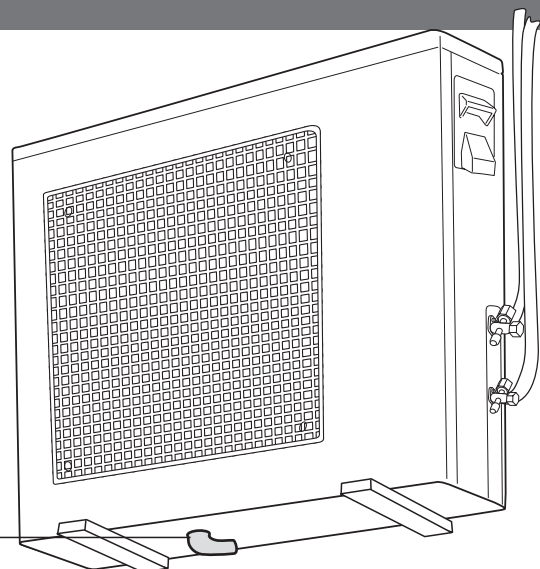
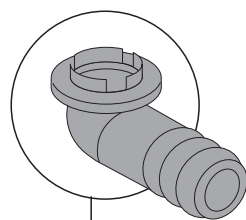

PIPES CONNECTIONS

CUTTING AND FLARING THE PIPES

1. Please use the pipe cutter for cutting the pipes.
2. Remove all burrs by using reamer. Gas leakage might happen if burrs are not removed!
Turn pipes edge down to avoid metal powder from entering down the pipes.
3. After inserting the flare nut into the copper pipes, please make a flare.

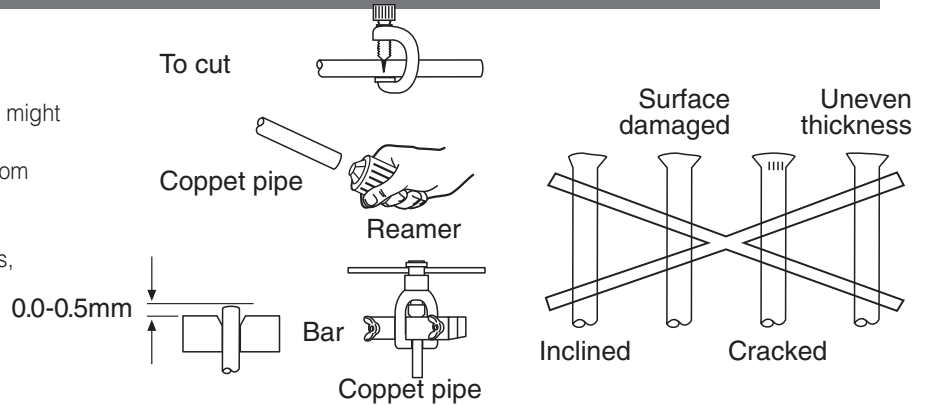

PIPE INSULATION

1. Please carry out insulation at pipe connection portion as mentioned in Indoor/ Outdoor Unit Installation Diagram. Please wrap the insulated piping end to prevent water from going inside the piping.
2. If drain hose or connecting pipes is in the room (where dew may form). Please increase the insulation by using POLY-E FOAM with thickness of 9 mm or more.

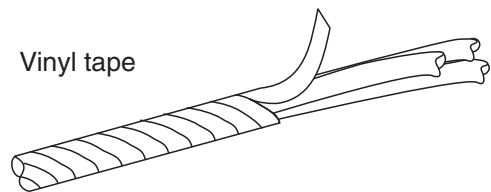

PIPES CONNECTIONS TO THE UNIT

Connecting to the indoor unit

1. Align the center of the pipes and finger tight the flare nut.
2. Use the torque wrench to tighten the nut firmly.

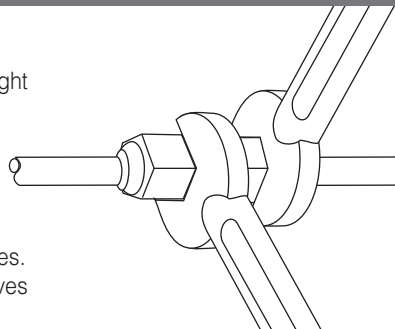

Connecting to the outdoor unit

1. Align the center of the pipes to the valves.
2. Use the torque wrench to tighten the valves firmly according to table:

Torque(N.m)	1/4	3/8	1/2	5/8	3/4
Flare Nuts	13-18	40-45	60-65	70-75	80-85
Valve Cap	13-20	13-20	18-25	18-25	40-50
Service Port Cap	11-13	11-13	11-13	11-13	11-13

EVACUATION OF PIPES AND INDOOR UNIT

After connection the unions of the indoor and outdoor units, purge the air from the tubes and from the indoor unit as follows:

1. Connect the charging hoses with a push pin to the low and high sides of the charging set and the service port of the suction and liquid valves. Be sure to connect the end of the charging hose with the push pin to the service port.
2. Connect the center hose of the charging set to a vacuum pump.
3. Turn on the power switch of the vacuum pump and make sure that the needle in the gauge moves from 0MPa (0cm Hg) to -0.1 MPa (-76cm Hg). Let the pump run for fifteen minutes.
4. Close the valves of both the low and high sides of the charging set and turn off the vacuum pump. Note that the needle in the gauge should not move after approximately five minutes.
5. Disconnect the charging hose from the vacuum pump and from the service ports of the suction and liquid valves.
6. Tighten the service port caps from both valves, and open them using a hexagonal Allen wrench.
7. Remove the valve caps from both valves, and open them using a hexagonal Allen wrench.
8. Remount valve caps onto both of the valves.
9. Check for gas leaks from the four unions and from the valve caps. Test with electronic leak detector or with a sponge immersed in soapy water for bubbles.

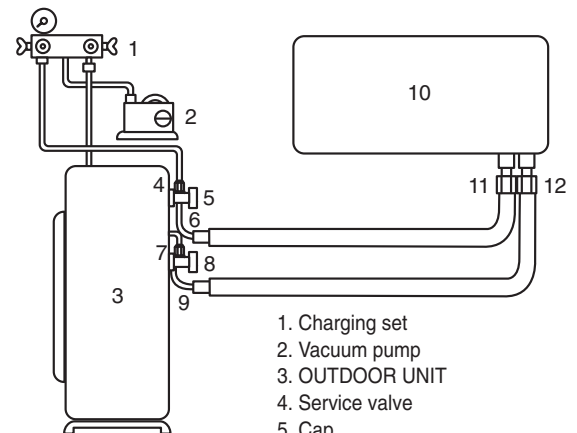

Sample

CAPACITY AND ADDITIONAL CHARGE FOR VARIOUS APPLICATIONS				
INDOOR	WNG 30	PXD 30	ECF XL 30	DNG 30
	FLO 30	SX 30	NXL 30	DLS 30
	NXE 80	TXE 80	CXE 80	NLS 80
COOLING CAPACITY	29500 Btu/h	28300 Btu/h	28300 Btu/h	29500 Btu/h
HEATING CAPACITY	29700 Btu/h	28300 Btu/h	29500 Btu/h	30700 Btu/h
REFRIGERANT CAPACITY	8700 g	8300 g	8500 g	9000 g
7 Pin-Flare				200gram
1Pin-3Pin		440gram		640gram
3Pin-3Pin			N/A	1140gram

REFRIGERANT R410A

1. Charging set
2. Vacuum pump
3. OUTDOOR UNIT
4. Service valve
5. Cap
6. Suction valve
7. Service valve*
8. Cap
9. Liquid valve
10. INDOOR UNIT
11. Suction flare connection
12. Liquid flare connection

NOTE: For additional charge of various tubing lengths, refer to outdoor unit table.

ELECTRICAL CONNECTIONS

ELECTRICAL SPECIFICATIONS

POWER SUPPLY		
	NOMINAL	VOLTAGE LIMITS
1PH	230/50/1	198-264V
3PH	400/50/3	360-440V

1PH UNITS		
CAP.	CIRCUIT BRAKER	POWER SUPPLY CABLE
5kw	20A	3 X 2.5MM ²
7kw	20A	3 X 2.5MM ²
9kw	25A	3 X 4MM ²
10.5kw	25A	3 X 4MM ²
12.5kw	40A	3 X 6MM ²

3PH UNITS		
CAP.	CIRCUIT BRAKER	POWER SUPPLY CABLE
5kw	3 X 10A	5 X 1.5MM ²
7kw	3 X 10A	5 X 1.5MM ²
9kw	3 X 16A	5 X 2.5MM ²
10.5kw	3 X 16A	5 X 2.5MM ²
12.5kw	3 X 16A	5 X 2.5MM ²
14kw	3 X 16A	5 X 2.5MM ²
16kw	3 X 20A	5 X 2.5MM ²

For main power supply and interconnecting use only cable H05RN-F type. Always follow local national wiring standards regulation.

All conductors should be of size and number as indicated in this page. Electrical cable should be in one piece without any joints. When mounting the cable under the floor please make sure it is perfectly protected and isolated from any possible contact with water. When the cable path runs through a wall or an acoustic ceiling, it must be protected with fireproof tubing. In addition, a telephone type cable, 2 x 0.5 mm, should interconnect the two units.

1. Prepare the multiple wire cable ends for connection.
2. Take away the Indoor/outdoor cover and open the terminals, take away the cable clamp screw and turn over the cable clamp.
3. Connect the cable ends to the terminals of the indoor and outdoor units.
4. Connect the other end of the twin wire cable to the outdoor unit twin wire terminal.
5. Secure the multiple wire power cable with the cable clamps.
6. Fasten the twin wire cable to the power cable with cable ties.

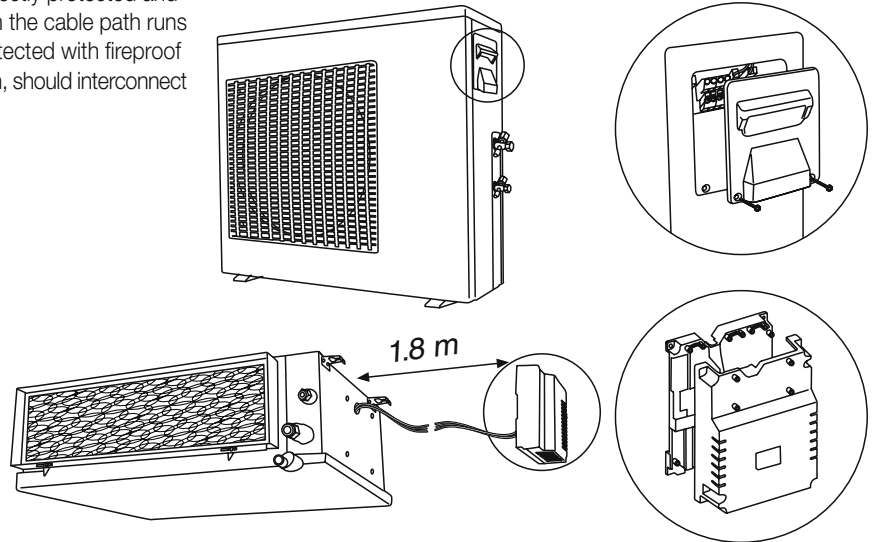

1PH Units Power supply to indoor (5Kw units)

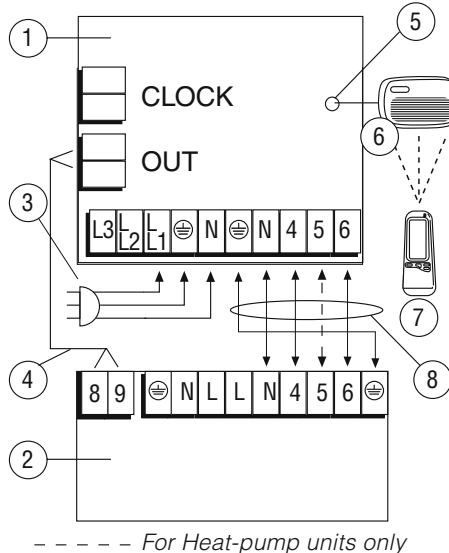

1. Indoor unit
2. Outdoor unit
3. Power supply cable
4. Control cable (2 x 0.5mm²)
5. Display connector
6. Display unit
7. Wireless remote control
8. Inter connecting cable (5 x 2.5mm²)

1PH Units Power supply to outdoor (7, 9, 10.5, 12.5Kw units)

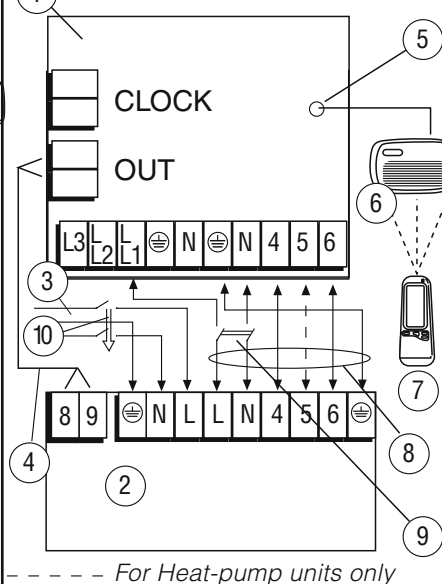

1. Indoor unit
2. Outdoor unit
3. Power supply cable
4. Control cable (2 x 0.5mm²)
5. Display connector
6. Display unit
7. Wireless remote control
8. Inter connecting cable (6 x 1.5mm²)
9. Safety Switch ON-OFF (by installer)
10. Power breaker (by installer)*

3PH Units Power supply to outdoor

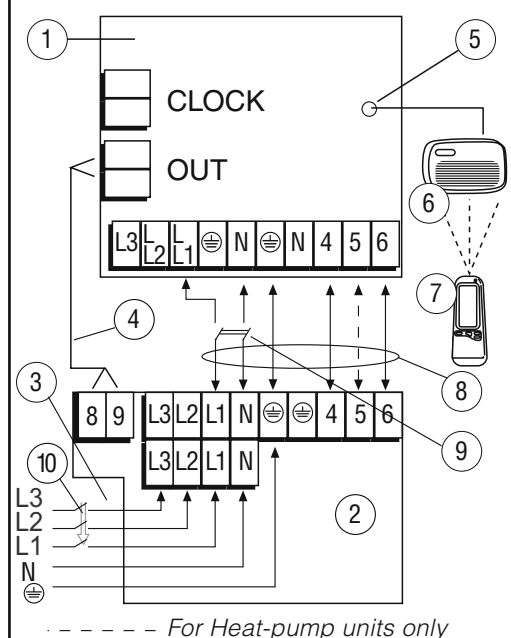

1. Indoor unit
2. Outdoor unit
3. Power supply cable
4. Control cable (2 x 0.5mm²)
5. Display connector
6. Display unit
7. Wireless remote control
8. Inter connecting cable (6 x 1.5mm²)
9. Safety Switch ON-OFF (by installer)
10. Power breaker (by installer)*

* The power breaker must be of type that disconnects all poles with 3 mm contact opening.

DISPLAY CONTROL UNIT

LOCATION CRITERIA

It is recommended to install the Display Control Unit close to a ceiling in a central and neutral zone at typical conditions. In addition, the aesthetic aspect should be considered. The Display Control Unit is connected to the main control board on the air conditioner (the indoor unit) by a communication cable. The cable is connected to the Display Control Unit by a quick-connector. (8 pin plug)

INSTALLATION OF DISPLAY CONTROL UNIT ON WALL

Drill a 12 mm diameter hole on the wall, for routing the communication cable

Open the unit cover, drill 3 holes in the wall to match the holes in the Display Control Unit, install the inserts and fasten the unit to the wall with 3 screws.

The Display Control Unit is provided of a special communication cable, 7 meters long, terminated by a plug, connected in the housing itself to a distribution box, which enables the control of the air conditioner from several different rooms, each one from its own Display Control Unit. Connect the quick connector to the appropriate socket on the main control board in the indoor unit electrical box.



WARNING

The plug should not be cut off the communication cable if the cable length is insufficient. In such case, a 5-meter extension cable may be added.

CONSIDERATIONS IN LOCATING THE REMOTE CONTROL UNIT

- Locate the Remote Control Unit in such a way that when mounted on its support on the wall, it will be in line sight with the Display Control Unit (at less than 8 m).
- It is recommended to establish the final location of the Remote Control Unit only after the first operation, assuring proper transmission and reception between the Remote Control Unit and the Display Control Unit.

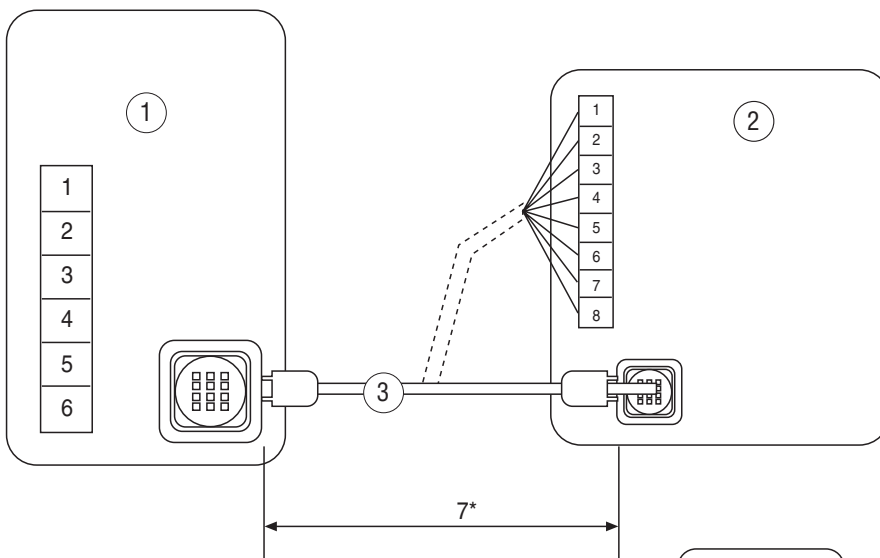

COLOR CHART	
Conn. Point	Wire Color
1	Gold
2	Green
3	Black
4	Brown
5	Purple
6	Yellow
7	Orange
8	Red

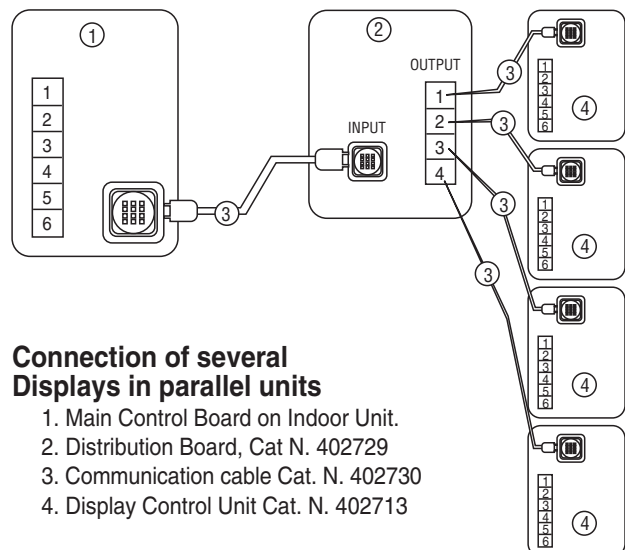

Connection of several Displays in parallel units

- Main Control Board on Indoor Unit.
- Distribution Board, Cat N. 402729
- Communication cable Cat. N. 402730
- Display Control Unit Cat. N. 402713

Check list before operation

CHECK THE DRAINAGE

Pour water into the drain tray-styrofoam.
Ensure that water flows out from drain hose of the indoor unit.

EVALUATION OF THE PERFORMANCE

Operate the unit at cooling mode and high fan speed for fifteen minutes or more.

Measure the temperature of the intake and discharge air.
Ensure the difference between the intake temperature and the discharge is more than 8 °C.

CHECK ITEMS

- | | |
|--|---|
| <input type="checkbox"/> Is there any gas leakage at flare nut connections? | <input type="checkbox"/> Is the indoor unit properly mounted to the ceiling? |
| <input type="checkbox"/> Has the heat insulation been carried out at flare nut connection? | <input type="checkbox"/> Is the power supply voltage complied with rated value? |
| <input type="checkbox"/> Is the connecting cable being fixed to terminal board firmly? | <input type="checkbox"/> Is there any abnormal sound? |
| <input type="checkbox"/> Is the connecting cable being clamped firmly? | <input type="checkbox"/> Is the cooling operation normal? |
| <input type="checkbox"/> Is the drainage OK?
(Refer to "Check the drainage" section) | <input type="checkbox"/> Is the thermostat operation normal? |
| <input type="checkbox"/> Is the earth wire connection properly done? | <input type="checkbox"/> Is the remote control's LCD operation normal? |

AIR VOLUME/STATIC PRESSURE

Static pr. (Pa)	15	20	30	40	50	60	70	80	90	100
Air Volume	(M ³ /Hr)	(M ³ /Hr)	(M ³ /Hr)	(M ³ /Hr)	(M ³ /Hr)	(M ³ /Hr)	(M ³ /Hr)	(M ³ /Hr)	(M ³ /Hr)	(M ³ /Hr)
5 Kw	High			1140	1120	1100	1080			
	Med	875	865	845	820					
	Low	710	700	680						
7 Kw	High			1195	1175	1150	1130			
	Med		1100	1080	1060	1040				
	Low	875	865	850	820					
9 Kw	High				1410	1380	1340	1310	1270	
	Med				1155	1125	1100	1070		
	Low		930	915	800	885				
10.5 Kw	High				1810	1780	1740	1710	1675	1640
	Med				1500	1415	1470	1455	1435	1420
	Low		1215	1205	1190	1180	1170			
12.5 Kw	High					2020	1990	1950	1910	1870
	Med					1480	1465	1450	1435	
	Low		1210	1200	1180					

Non working range area

