

OPERATING MANUAL

HAF/JAF/FHA Wall Mounted Range
R410A

CONTENT

FEATURES AND FUNTIONS..... 1
 PRECAUTIONS..... 2
 NAME OF EACH PART..... 3-4
 OPERATION TIPS..... 5
 PROTECTION MODES..... 6
 CARE AND MAINTENANCE..... 7-8
 TROUBLESHOOTING 9

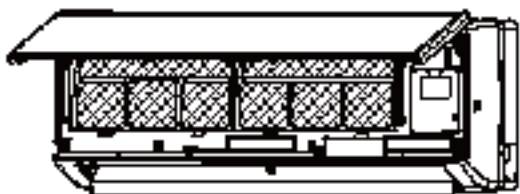

**Thank you for
 purchasing our
 Room Air Conditioner.**

Before using your air-conditioner, please read this operating instruction carefully and keep it for future reference.

Part No.468100399/01
 OM HAF/JAF/FHA 1-N.1 GB

FEATURES AND FUNCTIONS

VERTICAL AIR SWING

Automatic swing of supply air in vertical direction. The flap moves automatically in upward and downward direction to spread the conditioned air evenly throughout the room.

AUTO CHANGE OVER

The operation mode (cooling, dry, heating) is switched automatically to maintain the set temperature, and the set temperature is kept constant at all times.

WIRELESS REMOTE CONTROL UNIT

The Wireless Remote Control Unit allows convenient control of air conditioner operation.

SLEEP TIME

Designed to create comfortable sleeping conditions. When in COOLING mode, the temperature rises one degree centigrade after each consecutive hour, up to three hours, from the start of the mode. The temperature rise prevents the feeling of over-cooling while sleeping (when your body is at rest). In HEATING mode the reverse occurs; the air conditioner lowers its temperature one degree every hour. When in SLEEP mode, the air conditioner will be automatically turned off after seven hours. The result is a more comfortable and invigorating sleep, which leaves you feeling fresh and energetic in the morning.

OPERATING TEMPERATURE RANGE

		Indoor		Outdoor	
		DB[°C]	WB[°C]	DB[°C]	WB[°C]
Cooling	Upper limit	32	23	46	NA
	Lower limit	21	15	10	NA
Heating	Upper limit	27	NA	24	18
	Lower limit	10	NA	-15	-16

PRECAUTIONS

Danger

This sign warns of death or serious injury.

- Do not attempt to install this air conditioner by yourself.
- This unit contains no user-serviceable parts. Always consult authorized service personnel for installation and repairs.
- When moving, consult authorized service personnel for disconnection and installation of the unit.
- Do not become excessively chilled by staying for lengthy periods in the direct cooling airflow.
- Do not insert fingers or objects into the outlet port or intake grilles.
- Do not start and stop air conditioner operation by disconnecting the power supply cord and so on.
- Take care not to damage the power supply cord.
- In the event of a malfunction (burning smell, etc.), immediately stop operation, disconnect the power supply plug, and consult authorized service personnel.
- If the power supply cord of this appliance is damaged, it should only be replaced by the authorized service personnel, since special purpose tools and specified cord are required.
- The appliance is not intended for use by young children or infirm persons without supervision.
- Please pre-heat the air conditioner for at least 12 hours before operation. If use it for a long time, please keep the power on.

Danger

This sign warns of damage to property.

- Provide occasional ventilation during use.
- Do not direct air flow at fireplaces or heating apparatus.
- Do not climb on, or place objects on the air conditioner.
- Do not hang objects from the indoor unit.
- Do not set flower vases or water containers on top of air conditioner.
- Do not expose the air conditioner directly to water.
- Do not operate the air conditioner with wet hands.
- Do not pull power supply cord.
- Turn off power source when not using the unit for extended periods.
- Check the condition of the installation about damages.
- Do not place animals or plants in the direct path of the air flow.
- Do not drink the water drained from the air conditioner.
- Do not use in applications involving the storage of foods, plants or animals, precision equipment, or art works.
- Connection valves become hot during heating; handle with care.
- Do not apply any heavy pressure to heat exchanges fins.
- Operate only with air filters installed.
- Do not block or cover the intake grille and outlet port.
- Ensure that any electronic equipment is at least one metre away from either the indoor or outdoor units.
- Avoid installing the air conditioner near a fireplace or other heating apparatus.
- When installing the indoor and outdoor units, take precautions to prevent access to infants.
- Do not use inflammable gases near the air conditioner.

NAME OF EACH PART

INDOOR UNIT

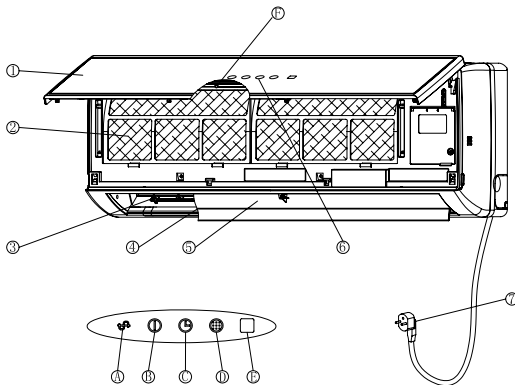

- ① Air intake grill
- ② Air filter
- ③ Supply air flap (louver)
- ④ Horizontal air flow deflecting louvers
- ⑤ Air outlet
- ⑥ Unit's indicators and on unit control
- ⑦ Power cord (optional)

A (Operation indicator)

Lights up during operation. Blinks once to announce that the remote control infrared signal has been received and stored. Blinks continuously in protection model.

B (Stand-By indicator)

Is on during STBY model and off during operation model.

C (Timer indicator)

Lights up during Timer and Sleep operation. Blinks when the timer is invalid when power failure occurred.

D (Filter indicator)

Lights up when air filter requires cleaning.

E (IR indicator)

Receives signals from the remote control.

F (Model Button and Reset Button)

As long as the filter Led is off, the Mode/Reset button functions as Mode switch. Once filter Led is on, the Mode/Reset button functions as Reset switch.

Mode Function:

Every short pressing, the next operation mode is selected, in this order: SB → Cool Mode → Heat Mode → SB → ...

Reset Function:

When Filter indicator is on, short pressing turns off the filter indicator and resets the filter function, after the cleaned filter has been reinstalled.

NAME OF EACH PART

Note: If there are some functions your unit does not have, pls disregard the relevant instructions.

If the air-conditioner can not be operated by the Remote Control unit, it can be turned on for cooling or heating, or completely turned off, by pressing MODE button on the air-conditioner. The MODE button will change the operating status of the unit between-COOLING-HEAT-ING-STAND BY in turn, going with the indicator light revealing changing.

OUTDOOR UNIT

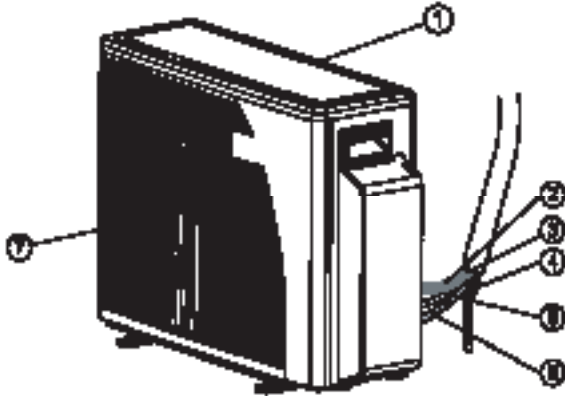

- | | |
|-----------------------------|-----------------------------|
| ① Out door unite air intake | ⑤ Liquid line |
| ② Power cable | ⑥ Suction line |
| ③ Control Wire (optional) | ⑦ Out door unite air outlet |
| ④ Darin hose | |

Note: These instructions also apply if the products differ externally to those appearing in the manual

OPERATION TIPS

- Set a suitable room temperature; excessively low room temperature is not good for your health and wastes electricity. Avoid frequent setting of the temperature.
- During cooling, avoid direct sun. Keep curtains and blinds closed. Close doors and windows to keep the cool air in the room.
- Avoid generating heat or using of heating appliances while the air conditioner in cooling mode.
- Make sure that the air flap is positioned properly: horizontal flow in cooling and downward vertical flow for heating.
- Keep the room temperature uniform by adjusting the left/right vertical air blades.
- Position the air flap and the left/right air blades in such a manner as to prevent your body from being exposed directly to air drafts.
- During prolonged operation, ventilate the room occasionally by opening a window from time to time.
- In a power failure, the microprocessor memory is retained. When restarted, operation will be resumed in the last mode of operation. After power failure, all pre-set times are cleared. The system is forced to stand-by and TIMER LED blinks. The blinking stops when any new message is accepted from RC.
- After turning on, allow more than 3 minutes for cooling, heating or dry operation to start.
- When DRY mode is used, make sure that the room temperature is between 20°C and 27°C. When used out of this range, the unit may protect itself and become inoperative.
- When COOL or DRY modes are used, make sure that the room's relative humidity is below 78%. If the unit is used for a prolonged periods of time in high humidity, moisture may form on the air outlet and drip down.
- Remote control signals may not be received if the indoor unit controls cover is exposed to direct sunlight or strong light. In such a case, block the sunlight or dim the lighting.
- The remote control is operative in a range of 8 meters. If you are out of range, the remote control may have difficulties in transmitting signals.

PROTECTION MODES (optional)

Your air-conditioner includes several automatic protection modes which enables you to use it virtually at any time and in any season regardless of the outdoor temperature. Some of the protection modes are listed below:

Mode	Operations conditions	Protection from	Controlled remedy
Cooling	Low outdoor temperature	Indoor coil freezes up	Stops outdoor fan and compressor when approaching freezing conditions Resumes operation automatically. Operating indicator blinks
	High outdoor temperature	Outdoor coil overheating	Stop compressor when approaching over heating conditions. Resumes operation automatically. Operating indicator blinks
Heating	Low outdoor temperature	Outdoor coil ice build up	Reverses Operation from heating to cooling for short periods to de-ice outdoor coil. Operating indicator blinks
	High Indoor or outdoor temperature	Indoor coil overheating	Stops outdoor fan and compressor when approaching high indoor coil temperature. Resumes operation automatically. Operating indicator blinks

Note: When switching the unit to OFF after heating operation, the unit may perform outdoor coil deicing operation. In such a case, the compressor will continue to run for some time after the unit has switched to OFF, and the indoor unit louvers are closed. This feature is a part of the normal unit operation

CARE AND MAINTENANCE

Before performing any maintenance procedure, make sure to disconnect the air conditioner from the power.

HOW TO CLEAN THE FLAT PANEL

The flat panel must be cleaned by soft cloth with water or mild cleanser.

Avoid using abrasive or corrosive cleanser.

Never apply any chemical for cleaning.

HOW TO REMOVE THE PANEL

Open the front panel and push it to the right, then pull out the right crank, and then pull the front panel to the left and take it out from the front frame.

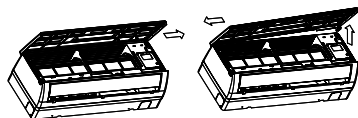

CLEANING THE AIR FILTER

To remove the air filters, lift up the panel, push the air filters up slightly to unlock them, pull out the filters, clean the filter by washing in warm soapy water and dry thoroughly. Align and fit the filters in place. Close the panel by pushing it in the center to lock it in place.

If your air conditioner is provided with a filter cleaning indicator, when the indicator lights up, you should remove the filters for cleaning, then use the Reset button to return off the indicator after cleaning.

DO NOT OPERATE THE UNIT WITHOUT FILTERS!

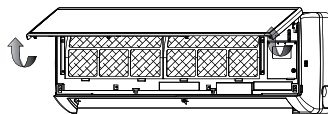
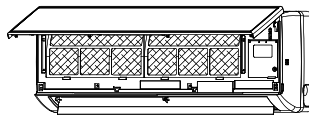

PURIFICATION FILTER REPLACEMENT

The air purifying filter should be removed from the unit and replaced once a year, show as following:

- 1 Pulling out the filter.
- 2 Replacing the filter in its place.

Note: The above procedure is used for replacing the active carbon filter (when supplied).

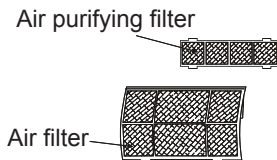

CARE AND MAINTENANCE

CLEANING THE AIR CONDITIONER

- Wipe the unit with a soft dry cloth or clean it using a vacuum cleaner.
- Do not use hot water or volatile materials which could damage the surface of the air conditioner.

AT THE BEGINNING OF THE SEASON

- Make sure there are no obstacles blocking the flow of inlet or outlet air, in both indoor and outdoor units.
- Make sure the power is properly connected.

PROTECT THE ELECTRONIC SYSTEM

- Indoor unit and remote control must be at least 1 meter away from a TV, radio or any other home electronic appliance.
- Protect the indoor unit from direct sun or lighting.

TROUBLESHOOTING

Before calling for service, please check the following common malfunctions and correct it as needed.

Problem	Cause	Remedy
<ul style="list-style-type: none"> Unit does not operate. Stand-by indicator does not light up 	<ul style="list-style-type: none"> Unit not connected to power Power failure 	<ul style="list-style-type: none"> Plug in the power cord Check main fuse
<ul style="list-style-type: none"> Unit does not operate. Stand-by indicator lights. 	<ul style="list-style-type: none"> Remote control malfunctions The remote control is locked 	<ul style="list-style-type: none"> Check remote control batteries Try to operate from a closer distance Start from on-unit controls Unlock the remote control
<ul style="list-style-type: none"> Unit does not respond properly to remote control command 	<ul style="list-style-type: none"> IR signal does not reach unit Distance between remote control and unit too large or aimed at from improper angle IR receiver on-unit exposed to strong light source 	<ul style="list-style-type: none"> Check for obstruction between unit and remote control. Clear if needed. Get closer to unit. Dim lights, fluorescent especially
<ul style="list-style-type: none"> Air does not blow out from indoor unit 	<ul style="list-style-type: none"> De-icing protection mode is activated Unit in AUTO FAN mode Over cooling in DRY 	<ul style="list-style-type: none"> Normal operation in HEATING mode Normal operation in DRY mode
<ul style="list-style-type: none"> COOLING, DRY or HEATING does not start immediately 	<ul style="list-style-type: none"> 3-min. Compressor delayed start 	<ul style="list-style-type: none"> Normal operation for these modes
<ul style="list-style-type: none"> Unit functions but does not perform sufficiently 	<ul style="list-style-type: none"> Improper temperature setting Unit capacity in sufficient for load or room size 	<ul style="list-style-type: none"> Reset temperature Consult your dealer