

Airwell

Service Manual

PRIME Series

Indoor Unit	Outdoor Unit
PRIME 7	GC 7A RC R410A
	GC 7A R410A
	GC RELAX 7 RC R22
PRIME 9	GCN 9 RC R410A (class A)
	GCN 9 R410A (class A)
	ODU WAP 9 RC R410A (class C)
	ODU WAP 9 R410A (class C)
	ODU WAP 9 RC R22
	ODU WAP 9 R22
PRIME 12 (A) R410A	GCN 12 RC R410A (class A)
	GCN 12 R410A (class A)
PRIME 12 (C) R410A	ODU WAP 12 RC R410A (class C)
	ODU WAP 12 R410A (class C)
PRIME 12 R22	ODU WAP 12 RC R22
	ODU WAP 12 R22
PRIME 18	GCN 17N RC R410A
	GCN 17N R410A
	GC RELAX 18N RC R22
	GC RELAX 18N R22



REFRIGERANT

R22

R410A

COOLING ONLY

HEAT PUMP

LIST OF EFFECTIVE PAGES

Note: Changes in the pages are indicated by a “Revision#” in the footer of each effected page (when none indicates no changes in the relevant page). All pages in the following list represent effected/ non effected pages divided by chapters.

Dates of issue for original and changed pages are:

Original 0 March 2007

Total number of pages in this publication is 137 consisting of the following:

Page No.	Revision No. #		Page No.	Revision No. #		Page No.	Revision No. #
----------	----------------	--	----------	----------------	--	----------	----------------

Title 0
 A 0
 i 0
 1-1 - 1-3 0
 2-1 - 2-6 0
 3-1 0
 4-1 - 4-2 0
 5-1 - 5-24 0
 6-1 - 6-6 0
 7-1 0
 8-1 - 8-2 0
 9-1 0
 10-1-10-2 0
 11-1 0
 12-1-12-31 0
 13-1-13-2 0
 14-1-14-22 0
 Appendix -A 0

- Zero in this column indicates an original page.

*Due to constant improvements please note that the data on this service manual can be modified with out notice.
 **Photos are not contractual

Table of Contents

1.	INTRODUCTION	1-1
2.	PRODUCT DATA SHEET	2-1
3.	RATING CONDITIONS	3-1
4.	OUTLINE DIMENSIONS	4-1
5.	PERFORMANCE DATA & PRESSURE CURVES	5-1
6.	SOUND LEVEL CHARACTERISTICS	6-1
7.	ELECTRICAL DATA.....	7-1
8.	WIRING DIAGRAMS	8-1
9.	ELECTRICAL CONNECTIONS.....	9-1
10.	REFRIGERATION DIAGRAMS.....	10-1
11.	TUBING CONNECTIONS.....	11-1
12.	CONTROL SYSTEM	12-1
13.	TROUBLESHOOTING	13-1
14.	EXPLODED VIEWS AND SPARE PARTS LISTS.....	14-1
15.	APPENDIX A	15-1

1. INTRODUCTION

1.1 General

The new **PRIME Series** wall mounted comprise the ST (cooling only) and RC (heat pump) models, as follows:

RC R410A

Indoor Units	Outdoor Units
PRIME 7	GC 7ARC R410A
PRIME 9	GCN 9 RC R410A (class A)
PRIME 9	ODU WAP 9 RC R410A (class C)
PRIME 12 (A) R410A	GCN 12 RC R410A (class A)
PRIME 12 (C) R410A	ODU WAP 12 RC R410A (class C)
PRIME 18	GCN 17 NRC R410A

ST R410A

Indoor Units	Outdoor Units
PRIME 7	GC 7ARC R410A
PRIME 9	GCN 9 RC R410A (class A)
PRIME 9	ODU WAP 9 RC R410A (class C)
PRIME 12 (A) R410A	GCN 12 RC R410A (class A)
PRIME 12 (C) R410A	ODU WAP 12 RC R410A (class C)
PRIME 18	GCN 17 NRC R410A

RC R22

Indoor Units	Outdoor Units
PRIME 7	GC RELAX 7 RC R22
PRIME 9	ODU WAP 9RC R22
PRIME 12 R22	ODU WAP 12RC R22
PRIME 18	GC RELAX 18 NRC R22

ST R22

Indoor Units	Outdoor Units
PRIME 9	ODU WAP 9 R22
PRIME 12 R22	ODU WAP 12 R22
PRIME 18	GC RELAX 18 N R22

The indoor **PRIME Series** units are available as LED display types, featuring esthetic design, compact dimensions, and low noise operation.

1.2 Main Features

The **Prime Series** benefits from the most advanced technological innovations, namely:

- R410A/R22 models.
- Microprocessor control

- Infrared remote control with liquid crystal display.
- Indoor large diameter cross flow fan, allowing low noise level operation.
- Bended indoor coil with treated aluminum fins and coating for improved efficiency.
- Easy access to the interconnecting tubing and wiring connections, so that removing the front grill or casing is not necessary.
- Refrigerant pipes can be connected to the indoor unit from 5 different optional directions.
- Automatic treated air sweep.
- Low indoor and outdoor noise levels.
- Easy installation and service.

1.3 Indoor Unit

The indoor unit is a wall mounted, and can be easily fitted to many types of residential and commercial applications.

1.4 Filtration

- Easily accessible, and re-usable pre-filters (mesh)

1.5 Control

The microprocessor indoor controller, and an infrared remote control, supplied as standard, provide complete operating function and programming. For further details please refer to the Operation Manual, Appendix A.

1.6 Outdoor Unit

The **PRIME Series** outdoor units can be installed as floor or wall mounted units by using a wall supporting bracket. For further information please refer to the Product Data Sheet, Chapter 2.

The rotary compressor driven by outdoor unit provides optimum performance and noise levels. A "Bluefin" hydrophilic treatment promotes the flow of condensates, and offers corrosion protection to maintain performance levels and increasing the service life. On the other hand, the anticorrosion treatment with a high density powder paint coating ensures high resistance whatever the operating conditions.

1.7 Tubing Connections

Flare type interconnecting tubing to be produced on site.
For further details please refer to the Installation Manual, Outdoor Chapter 3.

1.8 Inbox Documentation

Each unit is supplied with its own installation and operation manuals.

1.9 Matching Table

1.9.1 R410A

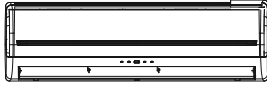
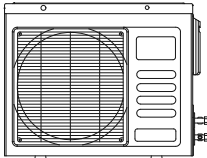
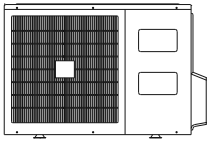
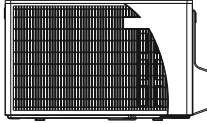
OUTDOOR UNITS		INDOOR UNITS				
						
MODEL		Prime7	Prime9	Prime12 (class A)	Prime12 (class C)	Prime18
	GC7	✓				
	CON9		✓			
	CON12				✓	
	GCN9		✓			
	GCN12			✓		
	ONG3-17					✓

1.9.2 R22

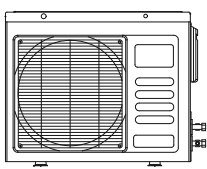
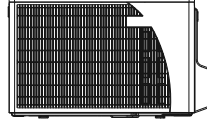
OUTDOOR UNITS		INDOOR UNITS			
					
MODEL		Prime7	Prime9	Prime12	Prime18\
	CON7	✓			
	CSP9		✓		
	CSP12			✓	
	ONG3-17				✓

2. PRODUCT DATA SHEET

2.1 PRIME 7 (Alpha 7 DF) / GC RELAX 7 (CON 7 R22)

Model Indoor Unit		PRIME 7(Alpha 7 DF)		
Model Outdoor Unit		GC RELAX 7 (CON 7 R22)		
Installation Method of Pipe		Flared		
Characteristics	Units	Cooling only	Cooling	Heating
Capacity (4)	Btu/hr	7230	7230	7340
	kW	2.12	2.12	2.15
Power input (4)	kW	0.75	0.75	0.67
EER (Cooling) or COP(Heating) (4)	W/W	2.83	2.83	3.21
Energy efficiency class		C	C	C
Power supply	V	220-240		
	Ph	1		
	Hz	50		
Rated current	A	3.4	3.4	3.1
Power factor		0.96	0.96	0.94
Prated (IDU)	W	25		
Prated (IDU+ODU)	W	830		
Starting current	A	16		
Circuit breaker rating	A	10		
INDOOR	Fan type & quantity		Crossflow x 1	
	Fan speeds	H/M/L	RPM	1150/ - /950
	Air flow (1)	H/M/L	m3/hr	400/ - /320
	External static pressure	Min	Pa	0
	Sound power level (2)	H/M/L	dB(A)	50/ - /45
	Sound pressure level(3)	H/M/L	dB(A)	37/ - /31
	Moisture removal		l/hr	0.7
	Condensate drain tube I.D		mm	16
	Dimensions	WxHxD	mm	680x250x180
	Net Weight		kg	7
	Package dimensions	WxHxD	mm	740x310x248
	Packaged weight		kg	9.5
	Units per pallet		units	32
	Stacking height		units	8levels
OUTDOOR	Refrigerant control		Capillary tube	
	Compressor type,model		Rotary,HITACHI SD134CV-H6AU	
	Fan type & quantity		Propeller(direct) x 1	
	Fan speeds	H	RPM	850
	Air flow	H	m3/hr	1200
	Sound power level	H	dB(A)	61
	Sound pressure level(3)	H	dB(A)	51
	Dimensions	WxHxD	mm	610x520x240
	Net Weight		kg	23
	Package dimensions	WxHxD	mm	725x550x355
	Packaged weight		kg	26
	Units per pallet		Units	12
	Stacking height		units	4 levels
	Refrigerant type			R22
	Standard charge		kg(4m)	0.5
	Additional charge			4m<Lin≤8m:+5g/m 8m<Lin≤10m:+9g/m
Connections between units	Liquid line	In.(mm)	1/4"(6.35)	
	Suction line	In.(mm)	3/8"(9.53)	
	Max.tubing length	m.	Max.10	
	Max.height difference	m.	Max.7	
Operation control type			Remote control	
Heating elements (Option)		kW		
Others				

- (1)Airflow in ducted units;at nominal external static pressure.
- (2)Sound power in ducted units is measured at air discharge.
- (3)Sound pressure level measured at 1-meter distance from unit.
- (4)Rating conditions in accordance to ISO 5151 and ISO 13253 (for ducted units)

2.2 PRIME 7 (Alpha 7 DF) / GC 7A (CON 7 R410A)

Model Indoor Unit		PRIME 7 (Alpha 7 DF)			
Model Outdoor Unit		GC 7A (CON 7 R410A)			
Installation Method of Pipe		Flared			
Characteristics		Units	Cooling Only	Cooling	Heating
Capacity (4)		Btu/hr	7400	7400	7540
		kW	2.17	2.17	2.21
Power input (4)		kW	0.66	0.66	0.63
EER (Cooling) or COP(Heating) (4)		W/W	3.29	3.29	3.51
Energy efficiency class			A	A	B
Power supply		V	220-240		
		Ph	1		
		Hz	50		
Rated current		A	2.9	2.9	2.8
Power factor			0.99	0.99	0.98
Starting current		A	15		
Circuit breaker rating		A	10		
INDOOR	Fan type & quantity			Crossflow x 1	
	Fan speeds	H/M/L	RPM	1150/850	
	Air flow (1)	H/M/L	m3/hr	390/320	
	External static pressure	Min-Max	Pa	0	
	Sound power level (2)	H/M/L	dB(A)	50/44	
	Sound pressure level(3)	H/M/L	dB(A)	37/32	
	Moisture removal		l/hr	0.8	
	Condensate drain tube I.D		mm	16	
	Dimensions	WxHxD	mm	680x180x250	
	Weight		kg	7	
	Package dimensions	WxHxD	mm	740x250x310	
	Packaged weight		kg	9.5	
	Units per pallet		units	36	
	Stacking height		units	9 levels	
OUTDOOR	Refrigerant control			Capillary tube	
	Compressor type,model			Rotary,TOSHIBA,PA82X1C-4DZDE	
	Fan type & quantity			Propeller(direct) x 1	
	Fan speeds	H/L	RPM	850	
	Air flow	H/L	m3/hr	1200	
	Sound power level	H/L	dB(A)	61	62
	Sound pressure level(3)	H/L	dB(A)	52	53
	Dimensions	WxHxD	mm	610x240x520	
	Weight		kg	27	27.5
	Package dimensions	WxHxD	mm	720x360x550	
	Packaged weight		kg	30/33.5(with kit)	30.5/34(with kit)
	Units per pallet		Units	12	
	Stacking height		units	4 levels	
	Refrigerant type			R410A	
	Refrigerant chargless distance		kg/m	0.72kg/7.5m	
	Additional charge			4m≤Length≤10m: +0g; 10m≤Length≤15m: +80g	
Connections between units	Liquid line	In.(mm)	1/4"(6.35)		
	Suction line	In.(mm)	3/8"(9.53)		
	Max.tubing length	m.	Max.15		
	Max.height difference	m.	Max.7		
Operation control type			Remote control		
Heating elements		kW			
Others					

(1)Airflow in ducted units;at nominal external static pressure.
 (2)Sound power in ducted units is measured at air discharge.
 (3)Sound pressure level measured at 1-meter distance from unit.
 (4)Rating conditions in accordance to ISO 5151 and ISO 13253 (for ducted units)

2.3 PRIME 9 (ASP 9 DF) / ODU WAP 9RC (CSP 9 RC R22)

Model Indoor Unit		PRIME 9 (ASP 9 DF)		
Model Outdoor Unit		ODU WAP 9RC (CSP 9 RC R22)		
Installation Method of Pipe		Flared		
Characteristics	Units	Cooling Only	Cooling	Heating
Capacity (4)	Btu/hr	8770	9050	9870
	kW	2.57	2.65	2.89
Power input (4)	kW	0.94	0.94	0.85
EER (Cooling) or COP(Heating) (4)	W/W	2.73	2.82	3.41
Energy efficiency class		D	C	B
Power supply	V	220-230		
	Ph	1		
	Hz	50		
Rated current	A	4.4	4.4	4.0
Power factor		0.95	0.95	0.95
Prated (IDU)	W	30		
Prated (IDU+ODU)	W	1090		
Starting current	A	26		
Circuit breaker rating	A	10		
INDOOR	Fan type & quantity		Crossflow x 1	
	Fan speeds	H/M/L	RPM	
	Air flow (1)	H/M/L	m3/hr	
	External static pressure	Min	Pa	
	Sound power level (2)	H/M/L	dB(A)	
	Sound pressure level(3)	H/M/L	dB(A)	
	Moisture removal		l/hr	
	Condensate drain tube I.D		mm	
	Dimensions	WxHxD	mm	
	Net Weight		kg	
	Package dimensions	WxHxD	mm	
	Packaged weight		kg	
	Units per pallet		units	
	Stacking height		units	
OUTDOOR	Refrigerant control		Capillary tube	
	Compressor type,model		Rotary,TOSHIBA PH170X1C-4DZDE3	
	Fan type & quantity		Propeller(direct) x 1	
	Fan speeds	H	RPM	
	Air flow	H	m3/hr	
	Sound power level	H	62	63
	Sound pressure level(3)	H	52	53
	Dimensions	WxHxD	mm	
	Net Weight		26	26.5
	Package dimensions	WxHxD	mm	
	Packaged weight		29	29.5
	Units per pallet		Units	
	Stacking height		units	
	Refrigerant type		R22	
	Refrigerant chargeless distance	kg(4m)	0.63	
	Additional charge		4m<Length≤8m:+5g/m; 8m<Lin≤15m:+15g/m	
	Connections between units	Liquid line	In.(mm)	1/4"(6.35)
Suction line		In.(mm)	3/8"(9.53)	
Max.tubing length		m.	Max.15	
Max.height difference		m.	Max.7	
Operation control type		Remote control		
Heating elements (Option)	kW			
Others				

(1)Airflow in ducted units;at nominal external static pressure.
 (2)Sound power in ducted units is measured at air discharge.
 (3)Sound pressure level measured at 1-meter distance from unit.
 (4)Rating conditions in accordance to ISO 5151 and ISO 13253 (for ducted units)

2.4 PRIME 9 (Alpha 9 R410A DF) / GCN 9A RC (GCN 9 RC R410)

Model Indoor Unit		PRIME 9 (ALPHA 9 R410A DF)			
Model Outdoor Unit		GCN 9A RC (GCN 9 RC R410A)			
Installation Method of Pipe		Flared			
Characteristics		Units	Cooling Only	Cooling	Heating
Capacity (4)		Btu/hr	9420	9420	10510
		kW	2.76	2.76	3.08
Power input (4)		kW	0.84	0.84	0.90
EER (Cooling) or COP(Heating) (4)		W/W	3.29	3.29	3.42
Energy efficiency class			A	A	B
Power supply		V	220-240		
		Ph	1		
		Hz	50		
Rated current		A	3.7	3.7	4.0
Power factor			0.99	0.99	0.98
Starting current		A	21.7		
Circuit breaker rating		A	10		
INDOOR	Fan type & quantity		Crossflow x 1		
	Fan speeds	H/M/L	RPM	1310/1100	
	Air flow (1)	H/M/L	m3/hr	450/360	
	External static pressure	Min-Max	Pa	0	
	Sound power level (2)	H/M/L	dB(A)	53/49	
	Sound pressure level(3)	H/M/L	dB(A)	41/35	
	Moisture removal		l/hr	1.2	
	Condensate drain tube I.D		mm	16	
	Dimensions	WxHxD	mm	680x180x250	
	Weight		kg	7	
	Package dimensions	WxHxD	mm	740x250x310	
	Packaged weight		kg	9.5	
	Units per pallet		units	36	
	Stacking height		units	9 levels	
OUTDOOR	Refrigerant control		Capillary tube		
	Compressor type,model		Rotary,TOSHIBA,PA108X1C-4FZDE		
	Fan type & quantity		Propeller(direct) x 1		
	Fan speeds	H/L	RPM	750	
	Air flow	H/L	m3/hr	1370	
	Sound power level	H/L	dB(A)	59	61
	Sound pressure level(3)	H/L	dB(A)	49	51
	Dimensions	WxHxD	mm	830x245x545	
	Weight		kg	32.5	33.5
	Package dimensions	WxHxD	mm	880x310x610	
	Packaged weight		kg	35/38.5(with kit)	36/39.5(with kit)
	Units per pallet		Units	9	
	Stacking height		units	3 levels	
	Refrigerant type			R410A	
	Refrigerant chargless distance		kg/m	0.85kg/7.5m	0.90kg/7.5m
	Additional charge			4m≤Length≤10m: +0g; 10m≤Length≤15m: +80g	4m≤Length≤10m: +0g; 10m≤Length≤15m: +80g
	Connections between units	Liquid line	In.(mm)	1/4"(6.35)	
Suction line		In.(mm)	3/8"(9.53)		
Max.tubing length		m.	Max.15		
Max.height difference		m.	Max.7		
Operation control type			Remote control		
Heating elements		kW			
Others					

- (1)Airflow in ducted units;at nominal external static pressure.
- (2)Sound power in ducted units is measured at air discharge.
- (3)Sound pressure level measured at 1-meter distance from unit.
- (4)Rating conditions in accordance to ISO 5151 and ISO 13253 (for ducted units)

2.5 PRIME 9 (ASP 9 R410A DF)/ODU WAP 9RC R410 (CSP 9R410A)

Model Indoor Unit		PRIME 9 (ASP 9 R410A DF)		
Model Outdoor Unit		ODU WAP 9RC R410 (CSP 9 R410A)		
Installation Method of Pipe		Flared		
Characteristics	Units	Cooling Only	Cooling	Heating
Capacity (4)	Btu/hr	8700	8700	9040
	kW	2.55	2.55	2.65
Power input (4)	kW	0.89	0.89	0.82
EER (Cooling) or COP(Heating) (4)	W/W	2.84	2.84	3.22
Energy efficiency class		C	C	C
Power supply	V	220-230		
	Ph	1		
	Hz	50		
Rated current	A	4.0	4.0	3.7
Power factor	W	0.97	0.97	0.97
Prated(IDU)	W	30		
Prated(IDU+ODU)	W	1072	1072	
Starting current	A	16.5		
Circuit breaker rating	A	10		
INDOOR	Fan type & quantity		Crossflow x 1	
	Fan speeds	H/M/L	RPM	
	Air flow (1)	H/M/L	m3/hr	
	External static pressure	Min	Pa	
	Sound power level (2)	H/M/L	dB(A)	
	Sound pressure level(3)	H/M/L	dB(A)	
	Moisture removal		l/hr	
	Condensate drain tube I.D		mm	
	Dimensions	WxHxD	mm	
	Net Weight		kg	
	Package dimensions	WxHxD	mm	
	Packaged weight		kg	
	Units per pallet		units	
	Stacking height		units	
OUTDOOR	Refrigerant control		Capillary tube	
	Compressor type,model		Rotary,Sanyo(Hua Run),C-1RV107	
	Fan type & quantity		Propeller(direct) x 1	
	Fan speeds	H	RPM	
	Air flow	H	m3/hr	
	Sound power level	H	62	62
	Sound pressure level(3)	H	51	51
	Dimensions	WxHxD	mm	
	Net Weight		23.5	24
	Package dimensions	WxHxD	mm	
	Packaged weight		26	26.5
	Units per pallet		Units	
	Stacking height		units	
	Refrigerant type		R410A	
	Standard charge	kg(7.5m)	0.58kg	
	Additional charge		4m≤Length≤10m: +0g; 10m≤Length≤15m: +50g	
Connections between units	Liquid line	In.(mm)	1/4"(6.35)	
	Suction line	In.(mm)	3/8"(9.53)	
	Max.tubing length	m.	Max.15	
	Max.height difference	m.	Max.7	
Operation control type		Remote control		
Heating elements	kW	Remote control(RC-5)		
Others				

- (1)Airflow in ducted units;at nominal external static pressure.
- (2)Sound power in ducted units is measured at air discharge.
- (3)Sound pressure level measured at 1-meter distance from unit.
- (4)Rating conditions in accordance to ISO 5151 and ISO 13253 (for ducted units)

2.6 PRIME 12 (ASP 12 DF) / ODU WAP 12RC R22 (CSP 12RC R22)

Model Indoor Unit			PRIME 12 (ASP 12 DF)		
Model Outdoor Unit			ODU WAP 12RC R22 (CSP 12 RC R22)		
Installation Method of Pipe			Flared		
Characteristics		Units	Cooling Only	Cooling	Heating
Capacity (4)		Btu/hr	11260	11260	12800
		kW	3.30	3.30	3.75
Power input (4)		kW	1.17	1.17	1.06
EER (Cooling) or COP(Heating) (4)		W/W	2.81	2.81	3.54
Energy efficiency class			C	C	B
Power supply		V	220-230		
		Ph	1		
		Hz	50		
Rated current		A	5.2	5.2	4.8
Power factor			0.95	0.95	0.95
Prated (IDU)		W	30		
Prated (IDU+ODU)		W	1425	1446	
Starting current		A	28		
Circuit breaker rating		A	10		
INDOOR	Fan type & quantity			Crossflow x 1	
	Fan speeds	H/M/L	RPM	1250/-/1000	
	Air flow (1)	H/M/L	m3/hr	650/-/500	
	External static pressure	Min	Pa	0	
	Sound power level (2)	H/M/L	dB(A)	55/-/49	
	Sound pressure level(3)	H/M/L	dB(A)	41/-/34	
	Moisture removal		l/hr	1.1	
	Condensate drain tube I.D		mm	16	
	Dimensions	WxHxD	mm	840x250x180	
	Net Weight		kg	7	
	Package dimensions	WxHxD	mm	900x310x248	
	Packaged weight		kg	9.5	
	Units per pallet		units	32	
	Stacking height		units	8evels	
	OUTDOOR	Refrigerant control			Capillary tube
Compressor type,model			Rotary,Sanyo,C-RV212H51BA		
Fan type & quantity			Propeller(direct) x 1		
Fan speeds		H	RPM	900	
Air flow		H	m3/hr	1200	
Sound power level		H	dB(A)	63	65
Sound pressure level(3)		H	dB(A)	52	54
Dimensions		WxHxD	mm	610x520x240	
Net Weight			kg	29.5	30
Package dimensions		WxHxD	mm	725x550x355	
Packaged weight			kg	31.5	32
Units per pallet			Units	12	
Stacking height			units	4 levels	
Refrigerant type				R22	
Refrigerant chargless distance			kg(7.5m)	0.88	
Additional charge				4m≤Length≤10m: +0g; 10m≤Length≤15m: +100g	
Connections between units		Liquid line	In.(mm)	1/4"(6.35)	
	Suction line	In.(mm)	1/2"(12.7)		
	Max.tubing length	m.	Max.15		
	Max.height difference	m.	Max.7		
Operation control type			Remote control		
Heating elements		kW			
Others					

- (1)Airflow in ducted units;at nominal external static pressure.
- (2)Sound power in ducted units is measured at air discharge.
- (3)Sound pressure level measured at 1-meter distance from unit.
- (4)Rating conditions in accordance to ISO 5151 and ISO 13253 (for ducted units)

2.7 PRIME 12A (ALPHA 12 R410A DF) / GCN12A RC R410A / GCN 12 RC R410A

Model Indoor Unit		PRIME 12A (ALPHA 12 R410A DF)		
Model Outdoor Unit		GCN12 A RC 410A (GCN 12 RC R410A)		
Installation Method of Pipe		Flared		
Characteristics	Units	Cooling Only	Cooling	Heating
Capacity (4)	Btu/hr	12280	12280	13030
	kW	3.60	3.60	3.82
Power input (4)	kW	1.12	1.12	1.11
EER (Cooling) or COP(Heating) (4)	W/W	3.21	3.21	3.44
Energy efficiency class		A	A	B
Power supply	V	220-240		
	Ph	1		
	Hz	50		
Rated current	A	4.9	4.9	4.9
Power factor		0.99	0.99	0.98
Starting current	A	31.5		
Circuit breaker rating	A	10		
INDOOR	Fan type & quantity		Crossflow x 1	
	Fan speeds	H/M/L	RPM	1210/950
	Air flow (1)	H/M/L	m3/hr	620/460
	External static pressure	Min-Max	Pa	0
	Sound power level (2)	H/M/L	dB(A)	53/47
	Sound pressure level(3)	H/M/L	dB(A)	40/33
	Moisture removal		l/hr	1.5
	Condensate drain tube I.D		mm	16
	Dimensions	WxHxD	mm	840x180x250
	Weight		kg	8
	Package dimensions	WxHxD	mm	930x250x310
	Packaged weight		kg	10.5
	Units per pallet		units	36
	Stacking height		units	9 levels
	OUTDOOR	Refrigerant control		Capillary tube
Compressor type,model		Rotary,TOSHIBA,PA145X2C-4FT		
Fan type & quantity		Propeller(direct) x 1		
Fan speeds		H/L	RPM	830
Air flow		H/L	m3/hr	1450
Sound power level		H/L	dB(A)	65
Sound pressure level(3)		H/L	dB(A)	54
Dimensions		WxHxD	mm	830x245x545
Weight			kg	37
Package dimensions		WxHxD	mm	880x310x610
Packaged weight			kg	39.5/43(with kit)
Units per pallet			Units	9
Stacking height			units	3 levels
Refrigerant type				R410A
Refrigerant chargless distance			kg/m	0.89kg/7.5m
Additional charge			4m≤Length≤10m: +0g; 10≤mLength≤15m: +80g	
Connections between units	Liquid line	In.(mm)	1/4"(6.35)	
	Suction line	In.(mm)	3/8"(9.53)	
	Max.tubing length	m.	Max.15	
	Max.height difference	m.	Max.7	
Operation control type		Remote control		
Heating elements		kW		
Others				

(1)Airflow in ducted units;at nominal external static pressure.
 (2)Sound power in ducted units is measured at air discharge.
 (3)Sound pressure level measured at 1-meter distance from unit.
 (4)Rating conditions in accordance to ISO 5151 and ISO 13253 (for ducted units)

2.8 PRIME 12C (ASP 12 R410A DF) / ODU WAP 12RC R410A (CSP 12 R410A)

Model Indoor Unit		PRIME 12C (ASP 12 R410A DF)		
Model Outdoor Unit		ODU WAP 12RC R410 (CSP 12 R410A)		
Installation Method of Pipe		Flared		
Characteristics	Units	Cooling Only	Cooling	Heating
Capacity (4)	Btu/hr	11260	11260	11600
	kW	3.30	3.30	3.40
Power input (4)	kW	1.16	1.16	1.05
EER (Cooling) or COP(Heating) (4)	W/W	2.84	2.84	3.22
Energy efficiency class		C	C	C
Power supply	V	220-230		
	Ph	1		
	Hz	50		
Rated current	A	5.13	5.13	4.65
Power factor		0.98	0.98	0.98
Prated(IDU)	W	30		
Prated(IDU+ODU)	W	1295	1440	
Starting current	A	28		
Circuit breaker rating	A	10		
INDOOR	Fan type & quantity		Crossflow x 1	
	Fan speeds	H/M/L	RPM	
	Air flow (1)	H/M/L	m3/hr	
	External static pressure	Min	Pa	
	Sound power level (2)	H/M/L	dB(A)	
	Sound pressure level(3)	H/M/L	dB(A)	
	Moisture removal		l/hr	
	Condensate drain tube I.D		mm	
	Dimensions	WxHxD	mm	
	Net Weight		kg	
	Package dimensions	WxHxD	mm	
	Packaged weight		kg	
	Units per pallet		units	
	Stacking height		units	
	OUTDOOR	Refrigerant control		Capillary tube
Compressor type,model		Rotary,Sanyo(Hua Run),C-RV133H1D		
Fan type & quantity		Propeller(direct) x 1		
Fan speeds		H	RPM	900
Air flow		H	m3/hr	1200
Sound power level		H	dB(A)	63
Sound pressure level(3)		H	dB(A)	53
Dimensions		WxHxD	mm	
Net Weight			kg	29
Package dimensions		WxHxD	mm	
Packaged weight			kg	31
Units per pallet			Units	12
Stacking height			units	4 levels
Refrigerant type			R410A	
Standard charge			kg(7.5m)	0.89kg
Additional charge		4m≤Length≤10m: +0g; 10m≤Length≤15m: +50g		
Connections between units	Liquid line	In.(mm)	1/4"(6.35)	
	Suction line	In.(mm)	3/8"(9.53)	
	Max.tubing length	m.	Max.15	
	Max.height difference	m.	Max.7	
Operation control type		Remote control		
Heating elements		kW		
Others		Remote control(RC-5)		

- (1)Airflow in ducted units;at nominal external static pressure.
- (2)Sound power in ducted units is measured at air discharge.
- (3)Sound pressure level measured at 1-meter distance from unit.
- (4)Rating conditions in accordance to ISO 5151 and ISO 13253 (for ducted units)

2.9 PRIME 18 (COMPACT-17) / GC RELAX 18N / ONG17 RC R22

Model Indoor Unit			PRIME 18 /COMPACT-17			
Model Outdoor Unit			GC RELAX 18 N / (ONG-17 RC R22)			
Installation Method of Pipe			Flared			
Characteristics		Units	Cooling only	Cooling	Heating	
Capacity (4)			18120	18150	19110	
			kW	5.31	5.32	5.60
Power input (4)			kW	1.81	1.86	1.79
EER (Cooling) or COP(Heating) (4)			W/W	2.93	2.86	3.13
Energy efficiency class			C	C	D	
Power supply			V	220-240		
			Ph	1		
			Hz	50		
Rated current			A	8.5	8.4	8.2
Power factor				0.32	0.33	0.32
Prated (IDU)			W	40		
Prated (IDU+ODU)			W	2350		
Starting current			A	36.8		
Circuit breaker rating			A	15		
INDOOR	Fan type & quantity		Crossflow x 1			
	Fan speeds	H/M/L	RPM	1200/ - /1000		
	Air flow (1)	H/M/L	m3/hr	720/ - /590		
	External static pressure	Min	Pa	0		
	Sound power level (2)	H/M/L	dB(A)	55/ - /50		
	Sound pressure level(3)	H/M/L	dB(A)	43/ - /37		
	Moisture removal			l/hr	2.4	
	Condensate drain tube I.D			mm	16	
	Dimensions	WxHxD	mm	900x295x200		
	Net Weight			kg	11	
	Package dimensions	WxHxD	mm	955x360x270		
	Packaged weight			kg	14	
	Units per pallet			units	21	
	Stacking height			units	7	
OUTDOOR	Refrigerant control		Capillary tube			
	Compressor type,model		Rotary,TOSHIBA PH330X2CS-4KT4			
	Fan type & quantity		Propeller(direct) x 1			
	Fan speeds	H	RPM	920		
	Air flow	H	m3/hr	2160		
	Sound power level	H	dB(A)	65	65	
	Sound pressure level(3)	H	dB(A)	53	54	
	Dimensions	WxHxD	mm	795x610x290		
	Net Weight			kg	43	44
	Package dimensions	WxHxD	mm	970x650x394		
	Packaged weight			kg	46	47
	Units per pallet			Units	9	
	Stacking height			units	3 Levels	
	Refrigerant type			R22		
	Standard charge			kg(7.5m)	1.12	1.40
	Additional charge			4m≤Lin≤10m:0g; 10m<Lin≤15m:+100g		
	Connections between units	Liquid line		In.(mm)	1/4"(6.35)	
Suction line			In.(mm)	1/2"(12.7)		
Max.tubing length			m.	Max.15		
Max.height difference			m.	Max.7		
Operation control type			Remote control			
Heating elements (Option)			kW			
Others						

(1)Airflow in ducted units;at nominal external static pressure.
 (2)Sound power in ducted units is measured at air discharge.
 (3)Sound pressure level measured at 1-meter distance from unit.
 (4)Rating conditions in accordance to ISO 5151 and ISO 13253 (for ducted units)

2.10 PRIME 18 (ALPHA 17 R410A DF) / GCN 17 NRC / ONG17 RC R410A

Model Indoor Unit		PRIME 18 (ALPHA 17 R410A DF)		
Model Outdoor Unit		GCN 17 NRC (ONG 17 RC R410A)		
Installation Method of Pipe		Flared		
Characteristics	Units	Cooling Only	Cooling	Heating
Capacity (4)	Btu/hr	18770	18770	19450
	kW	5.50	5.50	5.70
Power input (4)	kW	1.66	1.66	1.67
EER (Cooling) or COP(Heating) (4)	W/W	3.31	3.31	3.41
Energy efficiency class		A	A	B
Power supply	V	220-240		
	Ph	1		
	Hz	50		
Rated current	A	7.6	7.6	7.7
Power factor		0.95	0.95	0.95
Prated (IDU)	W	40		
Prated (IDU+ODU)	W	2150		
Starting current	A	32		
Circuit breaker rating	A	15		
INDOOR	Fan type & quantity		Cross flow*1	
	Fan speeds	H/M/L	RPM	
	Air flow (1)	H/M/L	m3/hr	
	External static pressure	Min	Pa	
	Sound power level (2)	H/M/L	dB(A)	
	Sound pressure level(3)	H/M/L	dB(A)	
	Moisture removal		l/hr	
	Condensate drain tube I.D		mm	
	Dimensions	WxHxD	mm	
	Net Weight		kg	
	Package dimensions	WxHxD	mm	
	Packaged weight		kg	
	Units per pallet		units	
	Stacking height		units	
OUTDOOR	Refrigerant control		Capillary tube	
	Compressor type,model		Rotary,TOSHIBA PA200X2CS-4KT1	
	Fan type & quantity		Propeller(direct) x 1	
	Fan speeds	H	RPM	
	Air flow	H	m3/hr	
	Sound power level	H	64	65
	Sound pressure level(3)	H	53	54
	Dimensions	WxHxD	mm	
	Net Weight		42	43
	Package dimensions	WxHxD	mm	
	Packaged weight		45/49(with kit)	46/50(with kit)
	Units per pallet		Units	
	Stacking height		units	
	Refrigerant type		R410A	
	Standard charge	kg(7.5m)	1.28	
	Additional charge		4m≤L≤10m: +0g;10m≤L≤15m: +100g	
Connections between units	Liquid line	In.(mm)	1/4"(6.35)	
	Suction line	In.(mm)	1/2"(12.7)	
	Max.tubing length	m.	15	
	Max.height difference	m.	7	
Operation control type		Remote control		
Heating elements (Option)		kW		
Others		All season kit Factory option		

- (1)Airflow in ducted units;at nominal external static pressure.
- (2)Sound power in ducted units is measured at air discharge.
- (3)Sound pressure level measured at 1-meter distance from unit.
- (4)Rating conditions in accordance to ISO 5151 and ISO 13253 (for ducted units)

3. RATING CONDITIONS

Standard conditions in accordance with ISO 5151, ISO 13253 (for ducted units) and EN 14511.

Cooling:

Indoor: 27°C DB 19°C WB

Outdoor: 35°C DB

Heating:

Indoor: 20°C DB

Outdoor: 7°C DB 6°C WB

3.1 Operating Limits

3.1.1 R410A

		Indoor	Outdoor
Cooling	Upper limit	32°C DB 23°C WB	46°C DB
	Lower limit	21°C DB 15°C WB	10°C DB
Heating	Upper limit	27°C DB	24°C DB 18°C WB
	Lower limit	10°C DB	-9°C DB -10°C WB
Voltage		198 – 264 V	

3.1.2 R22

		Indoor	Outdoor
Cooling	Upper limit	32°C DB 23°C WB	46°C DB
	Lower limit	21°C DB 15°C WB	10°C DB
Heating	Upper limit	27°C DB	24°C DB 18°C WB
	Lower limit	10°C DB	-5°C DB -10°C WB
Voltage		198 – 264 V	

4. OUTLINE DIMENSIONS

4.1 PRIME 7, 9

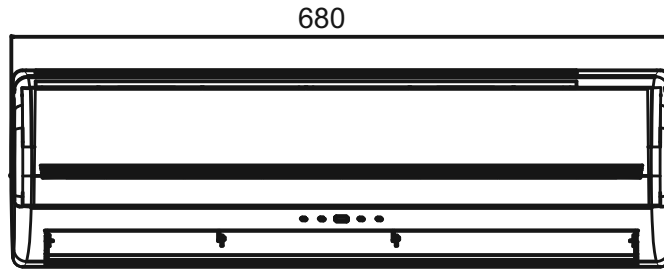
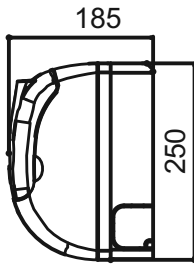
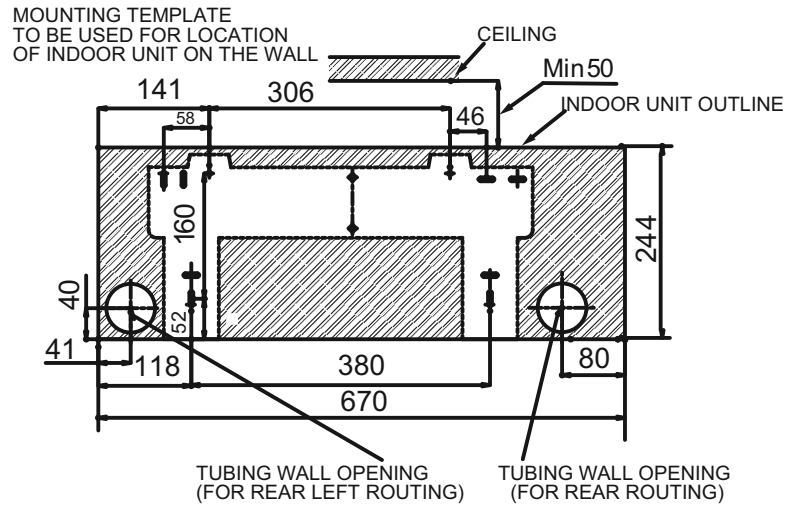

4.2 PRIME 12

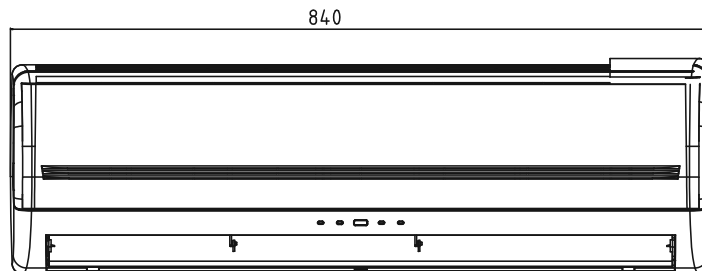
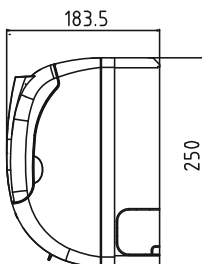
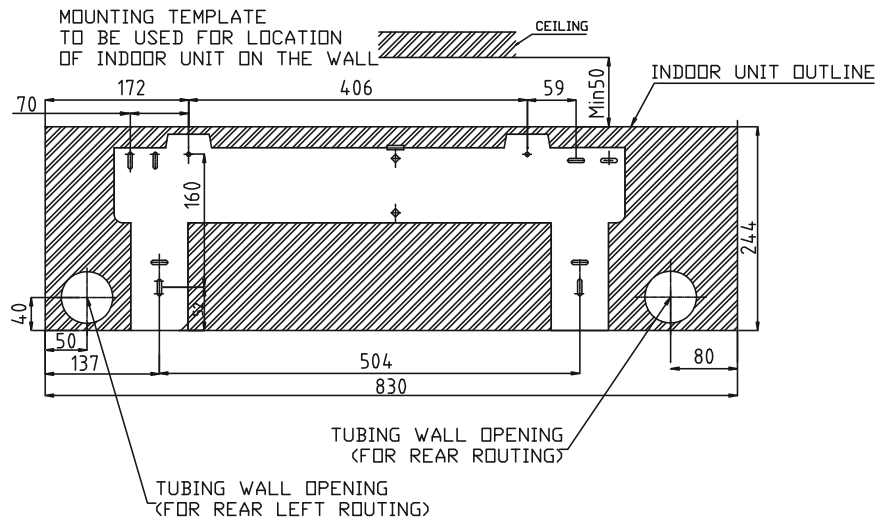

4.3 PRIME 18

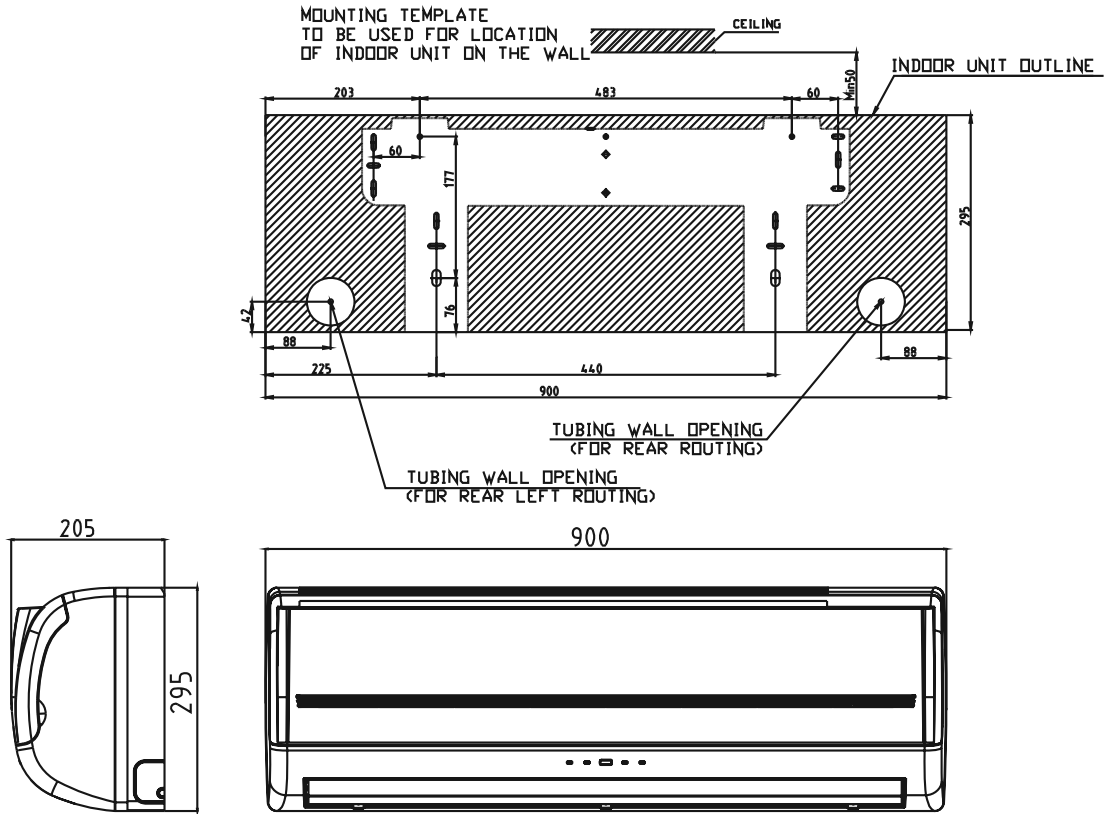

4.4 GC7, WAP9_12

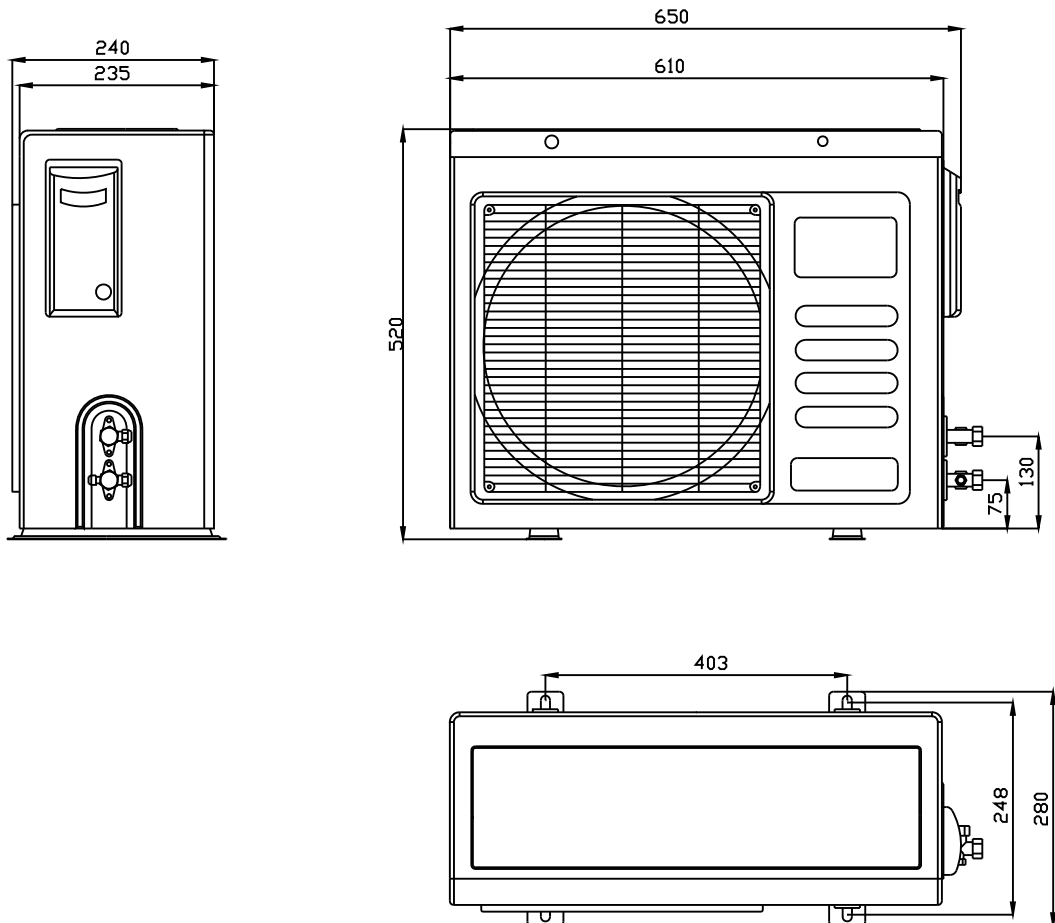

4.3 GCN9, 12

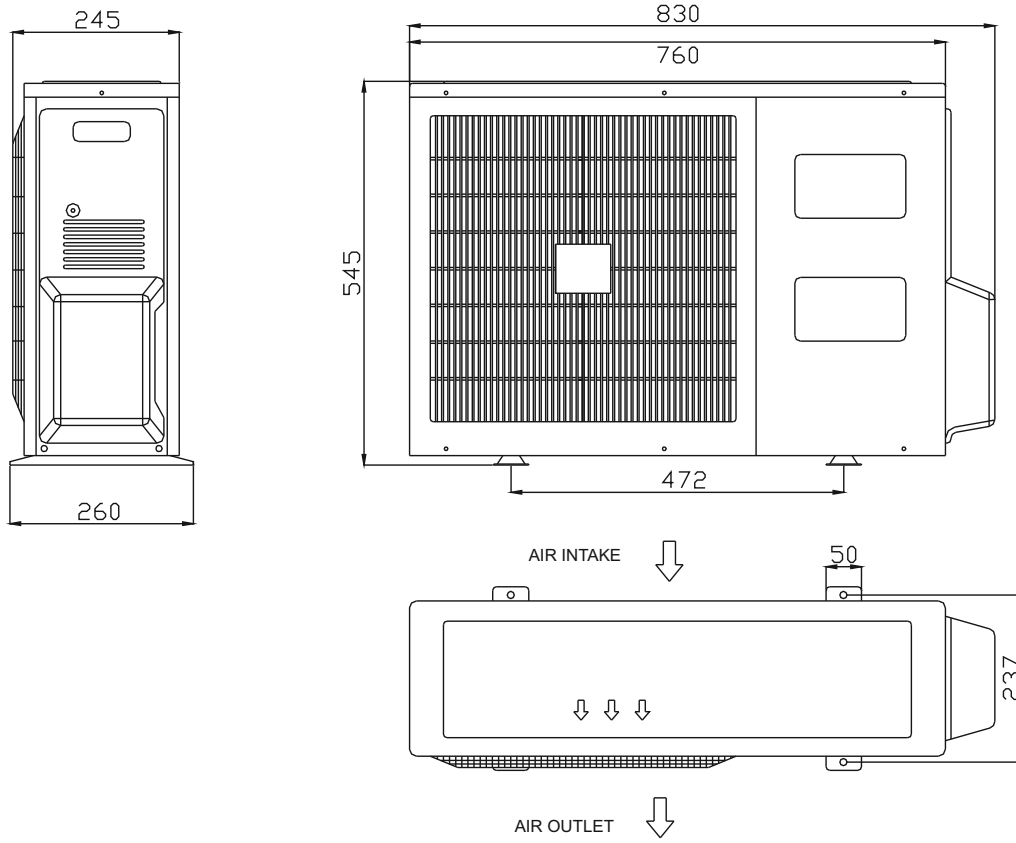

4.4 GC18, GCN18

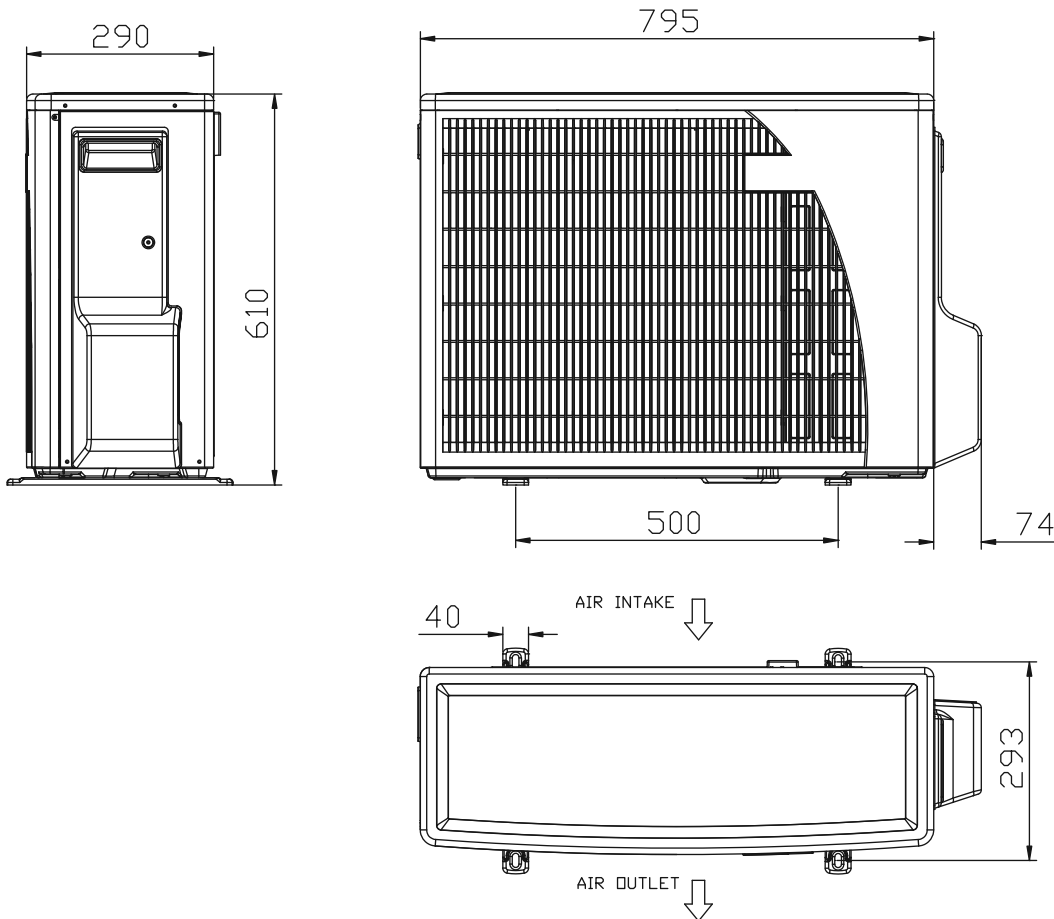

5. PERFORMANCE DATA & PRESSURE CURVES

5.1 Prime 7 / GC7 R410A

5.1.1 Cooling Mode at 7.5m Tubing Connection.

230V : Indoor Fan at High Speed.

Entering Air DB OD Coil(°C)	Data	Entering Air WB/DB ID Coil(°C)				
		15/21	17/24	19/27	21/29	23/32
15	TC	2.29	2.37	2.43	2.48	2.52
	SC	1.58	1.64	1.71	1.75	1.78
	PI	0.47	0.47	0.47	0.47	0.47
20	TC	2.21	2.33	2.41	2.46	2.52
	SC	1.55	1.63	1.70	1.75	1.78
	PI	0.51	0.51	0.51	0.51	0.52
25	TC	2.09	2.26	2.38	2.45	2.51
	SC	1.51	1.60	1.69	1.73	1.77
	PI	0.55	0.55	0.56	0.56	0.56
30	TC	1.96	2.13	2.30	2.39	2.46
	SC	1.46	1.55	1.65	1.70	1.73
	PI	0.59	0.60	0.61	0.61	0.62
35	TC	1.81	1.97	2.17	2.28	2.39
	SC	1.39	1.49	1.61	1.66	1.69
	PI	0.64	0.65	0.66	0.67	0.67
40	TC	1.65	1.79	1.96	2.14	2.25
	SC	1.31	1.41	1.52	1.57	1.60
	PI	0.69	0.70	0.71	0.72	0.73
46	TC	1.43	1.56	1.72	1.90	2.05
	SC	1.20	1.29	1.39	1.44	1.47
	PI	0.75	0.76	0.78	0.79	0.80

LEGEND

- TC – Total Cooling Capacity, kW
- SC – Sensible Capacity, kW
- PI – Power Input, kW
- WB – Wet Bulb Temp., (°C)
- DB – Dry Bulb Temp., (°C)
- ID – Indoor
- OD – Outdoor

(1) Marked area is below standard operating limits. For operating in low ambient conditions, an A.S.K Kit is required.

5.1.2 Heating

ENTERING WB OD COIL(°C)	ENTERING AIR DB ID COIL(°C)					
	15		20		25	
	TH	PI	TH	PI	TH	PI
-10	1.16	0.50	1.12	0.54	1.07	0.56
-7	1.25	0.52	1.20	0.55	1.16	0.57
-2	1.33	0.52	1.28	0.55	1.24	0.59
2	1.61	0.55	1.55	0.58	1.48	0.62
6	2.28	0.59	2.21	0.63	2.13	0.67
10	2.48	0.62	2.41	0.66	2.34	0.71
15	2.67	0.65	2.61	0.70	2.54	0.74
20	2.82	0.67	2.75	0.72	2.67	0.78

LEGEND

- TH – Total Heating Capacity, kW
- PI – Power Input, kW
- WB – Wet Bulb Temp., (°C)
- DB – Dry Bulb Temp., (°C)
- ID – Indoor
- OD – Outdoor

5.2 Model: Prime 7 / GC7 R410A

5.2.1 Cooling

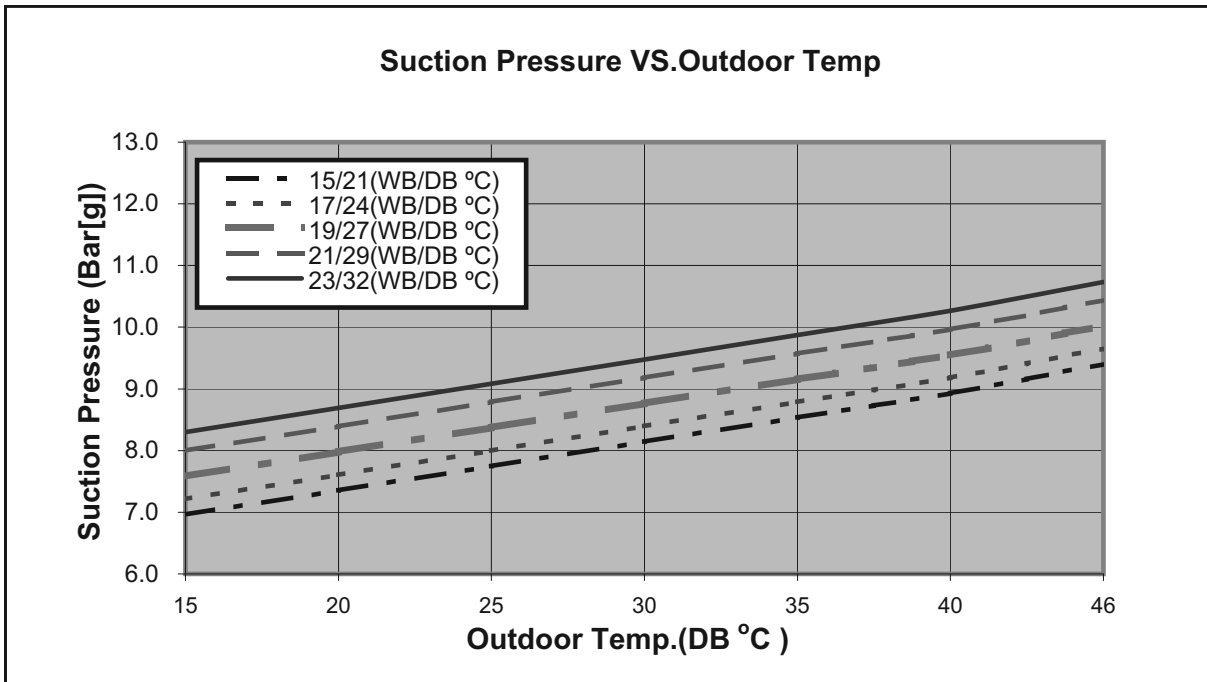
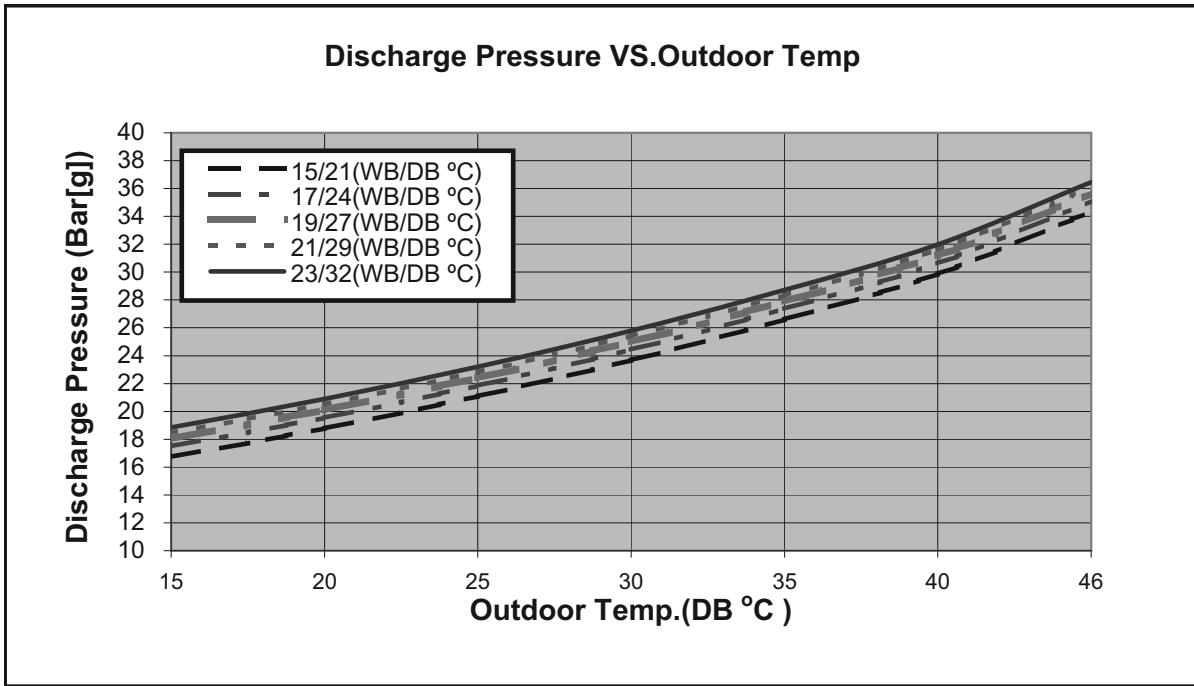

5.2.2 Heating

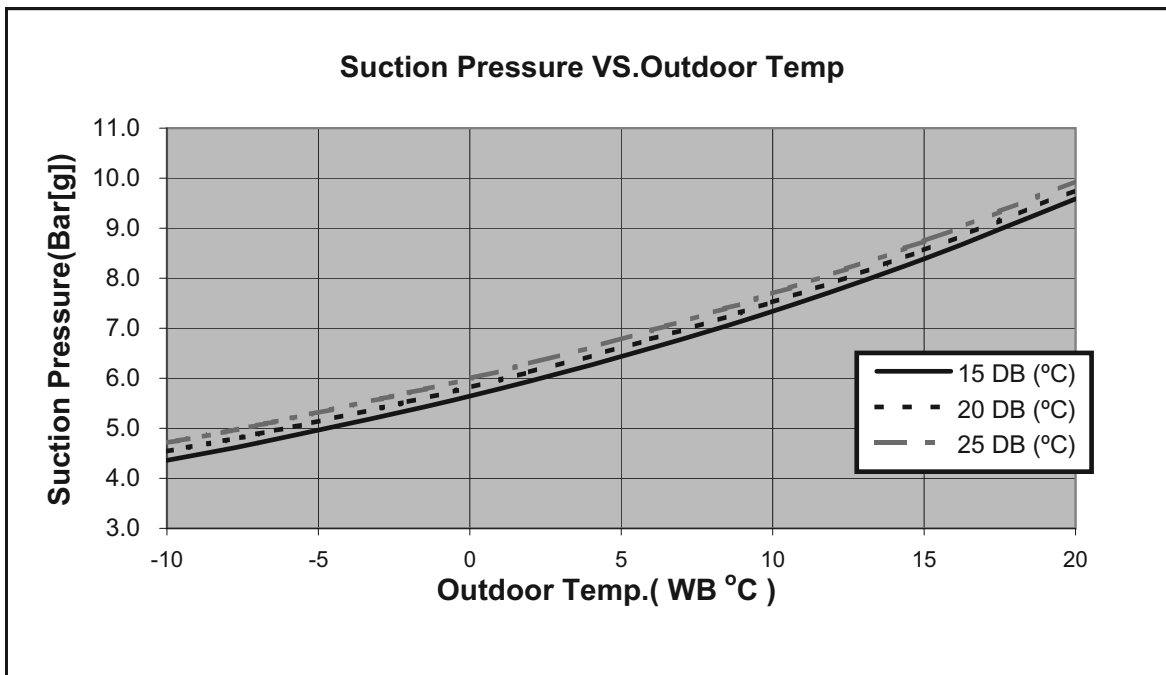
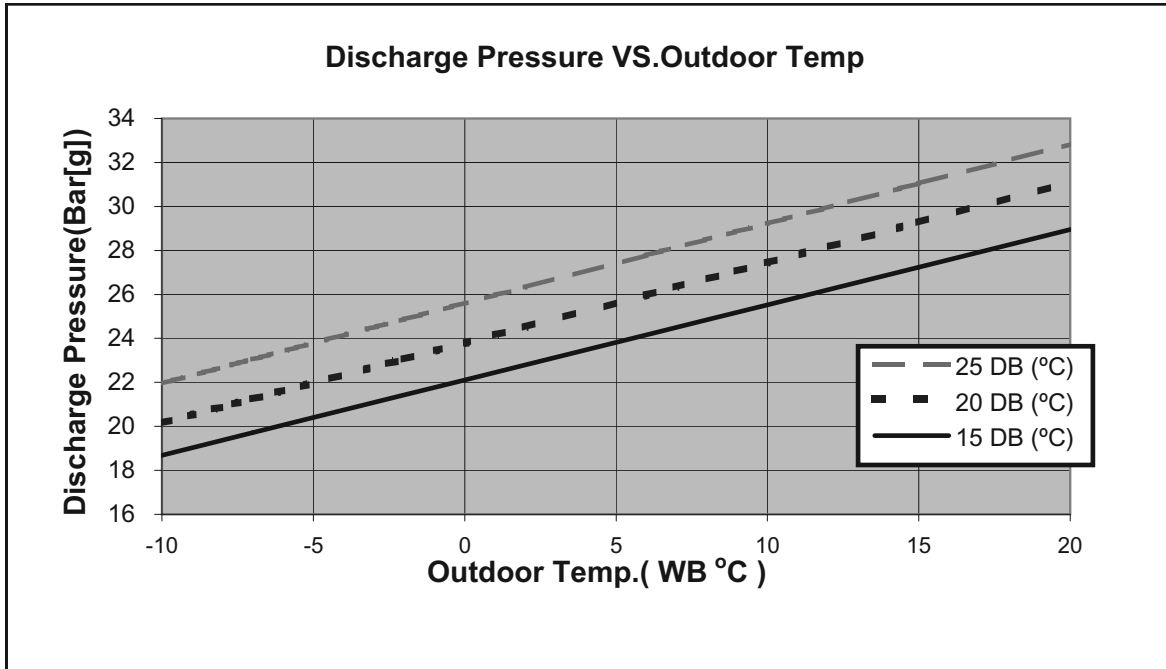

5.3 Prime 7 / GC Relax7 R22

5.3.1 Cooling Mode at 7.5m Tubing Connection.

230V : Indoor Fan at High Speed.

Entering Air DB OD Coil(°C)	Data	Entering Air WB/DB ID Coil(°C)				
		15/21	17/24	19/27	21/29	23/32
15	TC	2.23	2.31	2.37	2.43	2.46
	SC	1.53	1.59	1.66	1.70	1.73
	PI	0.53	0.53	0.53	0.54	0.54
20	TC	2.16	2.28	2.35	2.41	2.46
	SC	1.50	1.58	1.65	1.69	1.72
	PI	0.58	0.58	0.58	0.58	0.59
25	TC	2.05	2.21	2.32	2.39	2.45
	SC	1.46	1.55	1.63	1.68	1.71
	PI	0.62	0.63	0.63	0.64	0.64
30	TC	1.91	2.08	2.25	2.33	2.40
	SC	1.41	1.50	1.60	1.64	1.67
	PI	0.67	0.68	0.69	0.69	0.70
35	TC	1.77	1.92	2.12	2.23	2.33
	SC	1.34	1.44	1.56	1.61	1.64
	PI	0.73	0.74	0.75	0.76	0.76
40	TC	1.61	1.75	1.91	2.09	2.20
	SC	1.27	1.36	1.48	1.52	1.55
	PI	0.78	0.80	0.81	0.82	0.83
46	TC	1.40	1.53	1.68	1.86	2.00
	SC	1.17	1.25	1.35	1.39	1.42
	PI	0.86	0.87	0.89	0.90	0.91

LEGEND

- TC – Total Cooling Capacity, kW
- SC – Sensible Capacity, kW
- PI – Power Input, kW
- WB – Wet Bulb Temp., (°C)
- DB – Dry Bulb Temp., (°C)
- ID – Indoor
- OD – Outdoor

(1) Marked area is below standard operating limits. For operating in low ambient conditions, an A.S.K Kit is required.

5.3.2 Heating

ENTERING WB OD COIL(°C)	ENTERING AIR DB ID COIL(°C)					
	15		20		25	
	TH	PI	TH	PI	TH	PI
-10	1.13	0.54	1.09	0.57	1.04	0.60
-7	1.21	0.55	1.17	0.58	1.13	0.61
-2	1.29	0.56	1.25	0.59	1.20	0.62
2	1.57	0.58	1.51	0.62	1.44	0.66
6	2.21	0.63	2.15	0.67	2.07	0.71
10	2.41	0.66	2.34	0.71	2.28	0.76
15	2.60	0.69	2.54	0.74	2.47	0.79
20	2.74	0.71	2.68	0.77	2.60	0.83

LEGEND

- TH – Total Heating Capacity, kW
- PI – Power Input, kW
- WB – Wet Bulb Temp., (°C)_w
- DB – Dry Bulb Temp., (°C)
- ID – Indoor
- OD – Outdoor

5.4 Prime 7 / GC Relax7 R22

5.4.1 Cooling

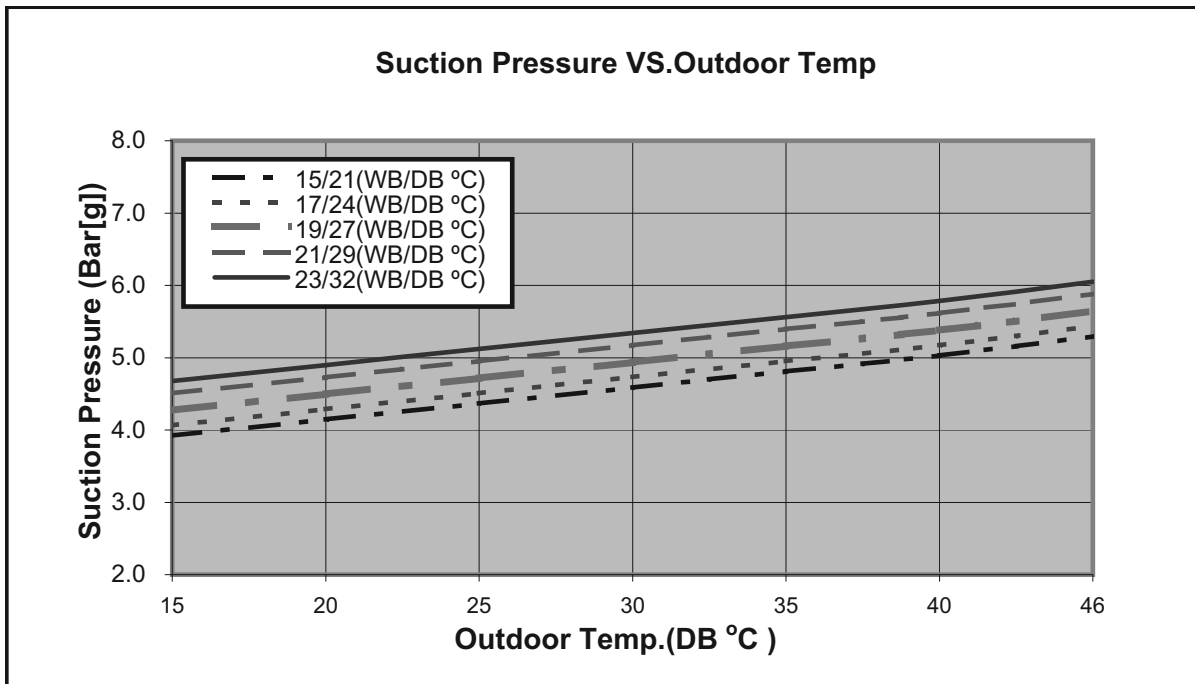
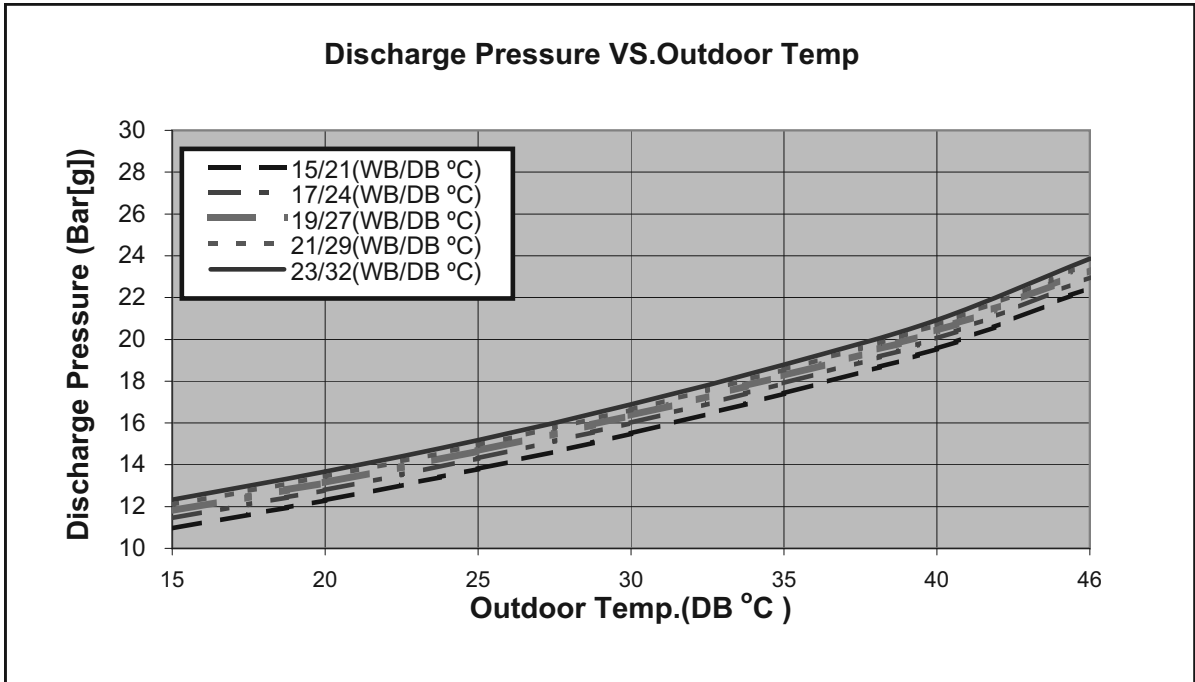

5.4.2 Heating

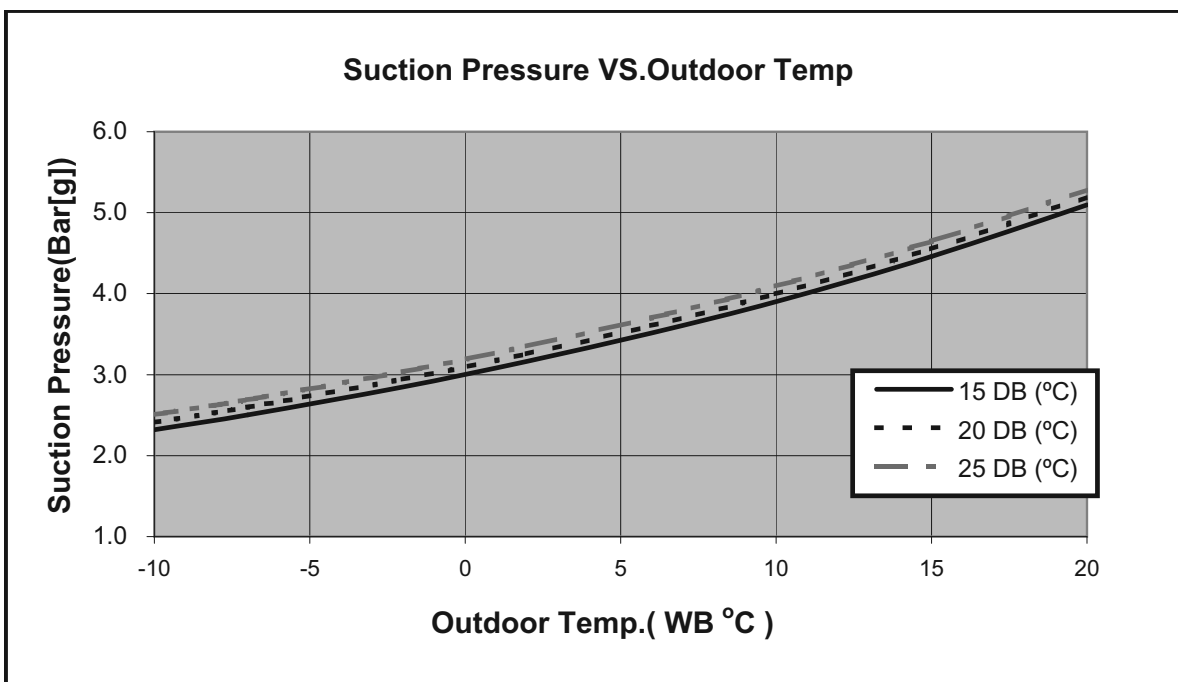
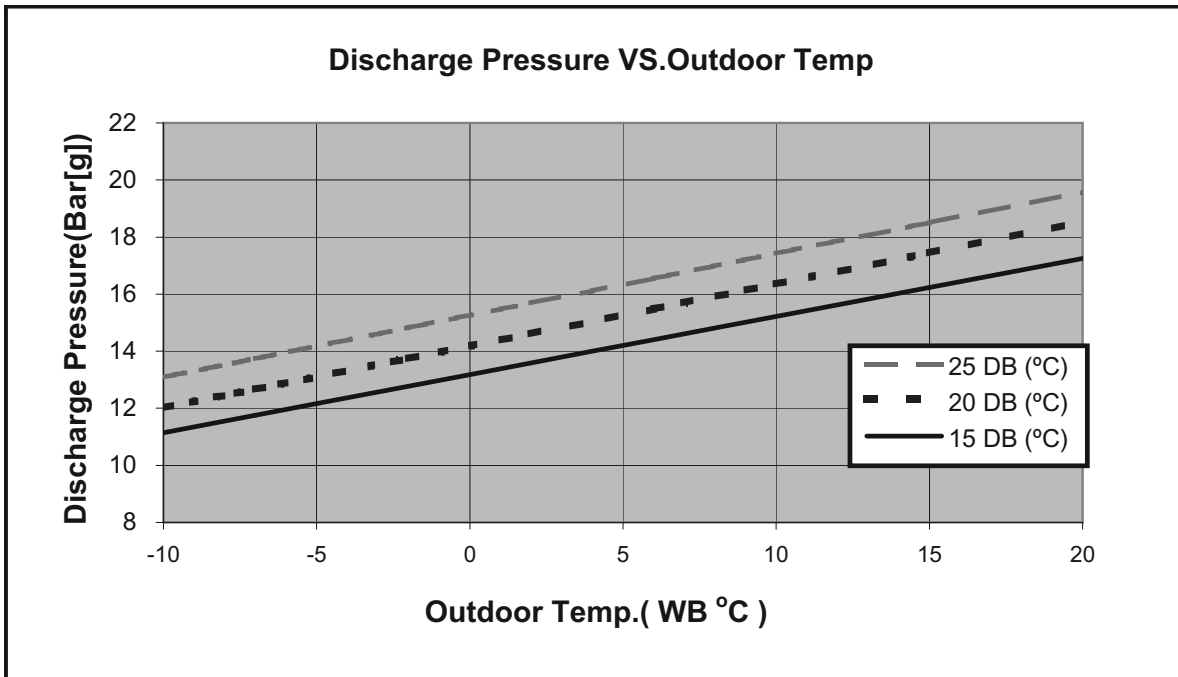

5.5 Prime 9 / GCN9 R410A

5.5.1 Cooling Mode at 7.5m Tubing Connection.

230V : Indoor Fan at High Speed.

Entering Air DB OD Coil(°C)	Data	Entering Air WB/DB ID Coil(°C)				
		15/21	17/24	19/27	21/29	23/32
15	TC	2.91	3.01	3.08	3.16	3.21
	SC	1.91	1.99	2.07	2.12	2.16
	PI	0.60	0.60	0.60	0.60	0.60
20	TC	2.81	2.97	3.06	3.13	3.20
	SC	1.87	1.97	2.06	2.12	2.15
	PI	0.65	0.65	0.65	0.65	0.66
25	TC	2.66	2.88	3.02	3.11	3.19
	SC	1.82	1.94	2.04	2.10	2.14
	PI	0.70	0.70	0.71	0.71	0.72
30	TC	2.49	2.71	2.93	3.03	3.12
	SC	1.77	1.88	2.00	2.05	2.09
	PI	0.75	0.76	0.77	0.78	0.78
35	TC	2.31	2.50	2.76	2.90	3.04
	SC	1.68	1.80	1.95	2.01	2.05
	PI	0.81	0.83	0.84	0.85	0.85
40	TC	2.10	2.28	2.49	2.72	2.86
	SC	1.58	1.70	1.84	1.90	1.94
	PI	0.88	0.89	0.91	0.92	0.93
46	TC	1.82	1.99	2.19	2.42	2.60
	SC	1.46	1.56	1.68	1.74	1.78
	PI	0.96	0.97	0.99	1.01	1.02

LEGEND

- TC – Total Cooling Capacity, kW
- SC – Sensible Capacity, kW
- PI – Power Input, kW
- WB – Wet Bulb Temp., (°C)
- DB – Dry Bulb Temp., (°C)
- ID – Indoor
- OD – Outdoor

(1) Marked area is below standard operating limits. For operating in low ambient conditions, an A.S.K Kit is required

5.5.2 Heating

ENTERING WB OD COIL(°C)	ENTERING AIR DB ID COIL(°C)					
	15		20		25	
	TH	PI	TH	PI	TH	PI
-10	1.62	0.72	1.56	0.77	1.49	0.81
-7	1.74	0.74	1.68	0.78	1.62	0.82
-2	1.85	0.75	1.79	0.79	1.72	0.84
2	2.25	0.78	2.16	0.83	2.06	0.88
6	3.17	0.84	3.08	0.90	2.97	0.96
10	3.45	0.89	3.36	0.95	3.26	1.02
15	3.73	0.93	3.63	1.00	3.54	1.06
20	3.93	0.95	3.83	1.04	3.73	1.12

LEGEND

- TH – Total Heating Capacity, kW
- PI – Power Input, kW
- WB – Wet Bulb Temp., (°C)
- DB – Dry Bulb Temp., (°C)
- ID – Indoor
- OD – Outdoor

5.6 Model: Prime 9 / GCN9 R410A

5.6.1 Cooling

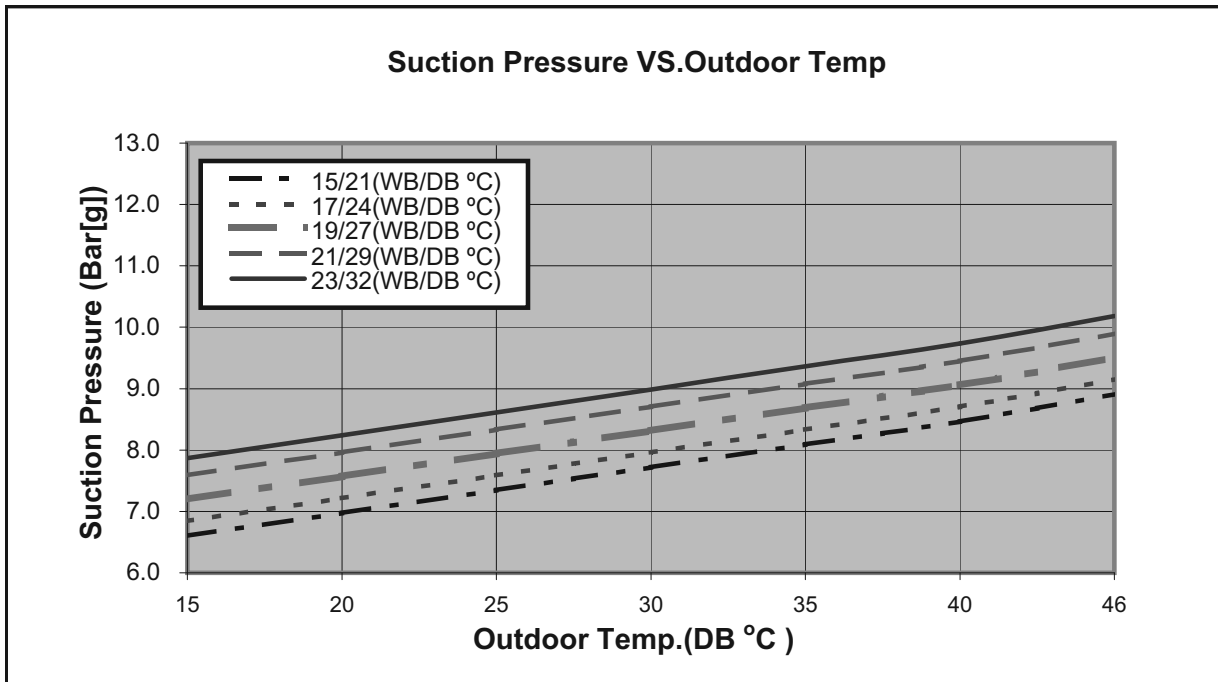
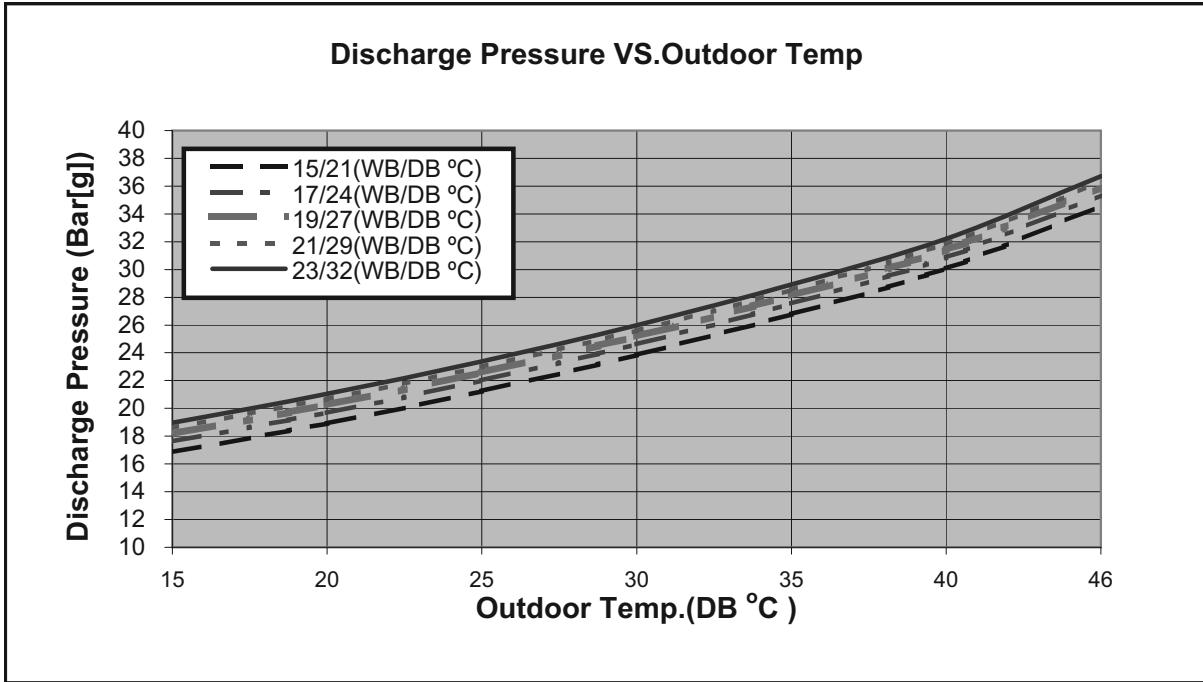

5.6.2 Heating

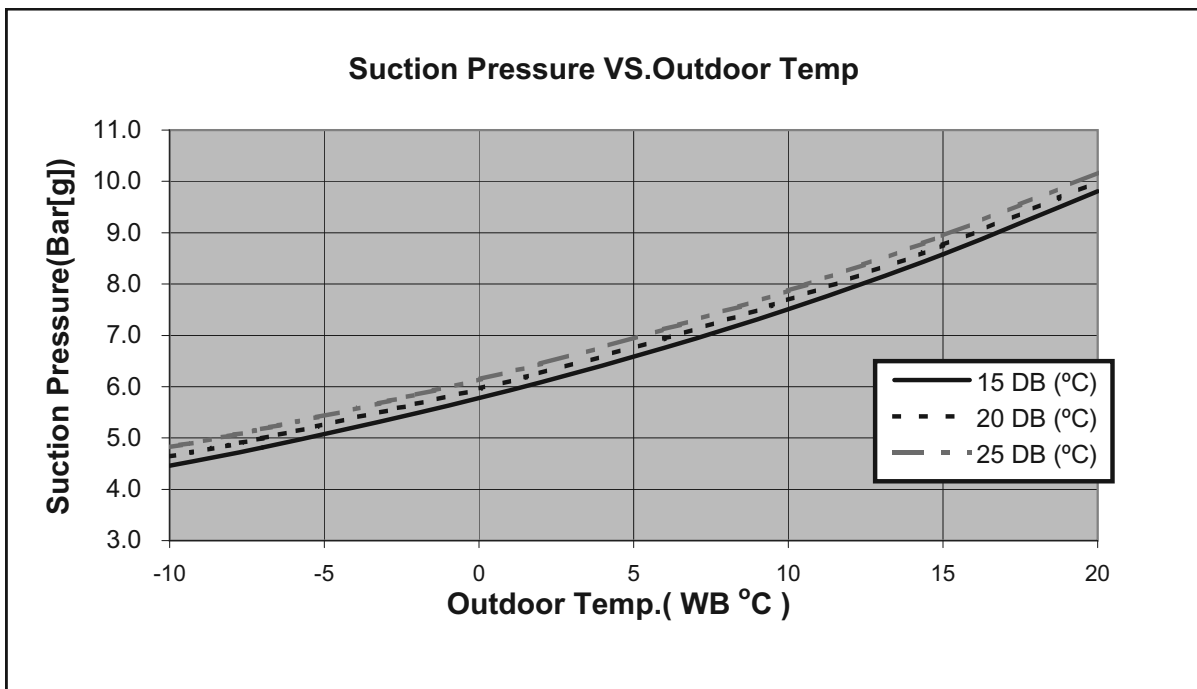
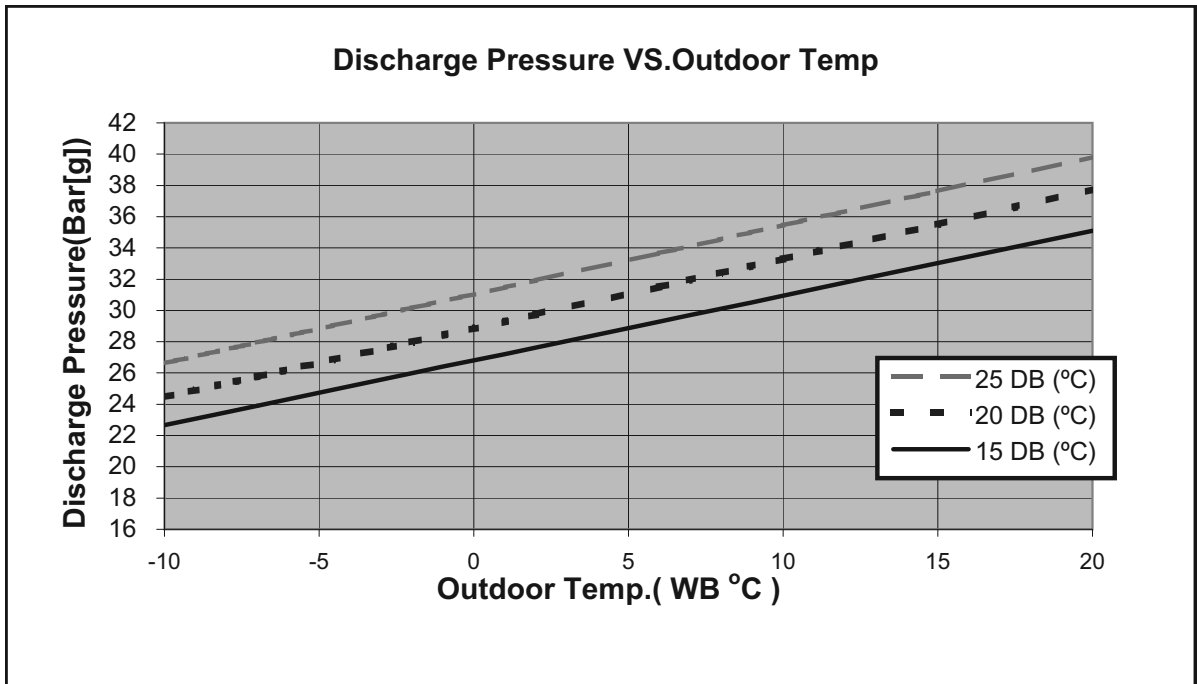

5.7 Model: Prime 9 / WAP9 R410A

5.7.1 Cooling Mode at 7.5m Tubing Connection.

230V : Indoor Fan at High Speed.

Entering Air DB OD Coil(°C)	Data	Entering Air WB/DB ID Coil(°C)				
		15/21	17/24	19/27	21/29	23/32
15	TC	2.69	2.78	2.85	2.92	2.96
	SC	1.90	1.98	2.06	2.11	2.15
	PI	0.63	0.63	0.63	0.63	0.64
20	TC	2.60	2.74	2.83	2.89	2.96
	SC	1.86	1.96	2.05	2.10	2.14
	PI	0.69	0.69	0.69	0.69	0.69
25	TC	2.46	2.66	2.79	2.88	2.95
	SC	1.81	1.93	2.03	2.09	2.13
	PI	0.74	0.75	0.75	0.76	0.76
30	TC	2.30	2.51	2.71	2.80	2.89
	SC	1.76	1.87	1.99	2.04	2.08
	PI	0.80	0.81	0.82	0.82	0.83
35	TC	2.13	2.31	2.55	2.68	2.80
	SC	1.67	1.79	1.94	2.00	2.04
	PI	0.86	0.88	0.89	0.90	0.90
40	TC	1.94	2.11	2.30	2.52	2.65
	SC	1.57	1.70	1.84	1.89	1.93
	PI	0.93	0.94	0.96	0.97	0.98
46	TC	1.68	1.84	2.02	2.23	2.41
	SC	1.45	1.55	1.67	1.73	1.77
	PI	1.02	1.03	1.05	1.07	1.08

LEGEND

- TC – Total Cooling Capacity, kWv
- SC – Sensible Capacity, kW
- PI – Power Input, kW
- WB – Wet Bulb Temp., (°C)
- DB – Dry Bulb Temp., (°C)
- ID – Indoor
- OD – Outdoor

(1) Marked area is below standard operating limits. For operating in low ambient conditions, refer to Optional Accessories (Chapter 15).

5.7.2 Heating

ENTERING WB OD COIL(°C)	ENTERING AIR DB ID COIL(°C)					
	15		20		25	
	TH	PI	TH	PI	TH	PI
-10	1.39	0.66	1.34	0.70	1.29	0.73
-7	1.50	0.67	1.44	0.71	1.39	0.75
-2	1.59	0.68	1.54	0.72	1.48	0.76
2	1.93	0.71	1.86	0.76	1.78	0.80
6	2.73	0.77	2.65	0.82	2.56	0.87
10	2.97	0.81	2.89	0.87	2.81	0.93
15	3.21	0.84	3.13	0.91	3.05	0.97
20	3.38	0.87	3.30	0.94	3.21	1.02

LEGEND

- TH – Total Heating Capacity, kW
- PI – Power Input, kW
- WB – Wet Bulb Temp., (°C)
- DB – Dry Bulb Temp., (°C)
- ID – Indoor
- OU – Outdoor

5.8. Model: Prime 9 / WAP9 R410A

5.8.1 Cooling

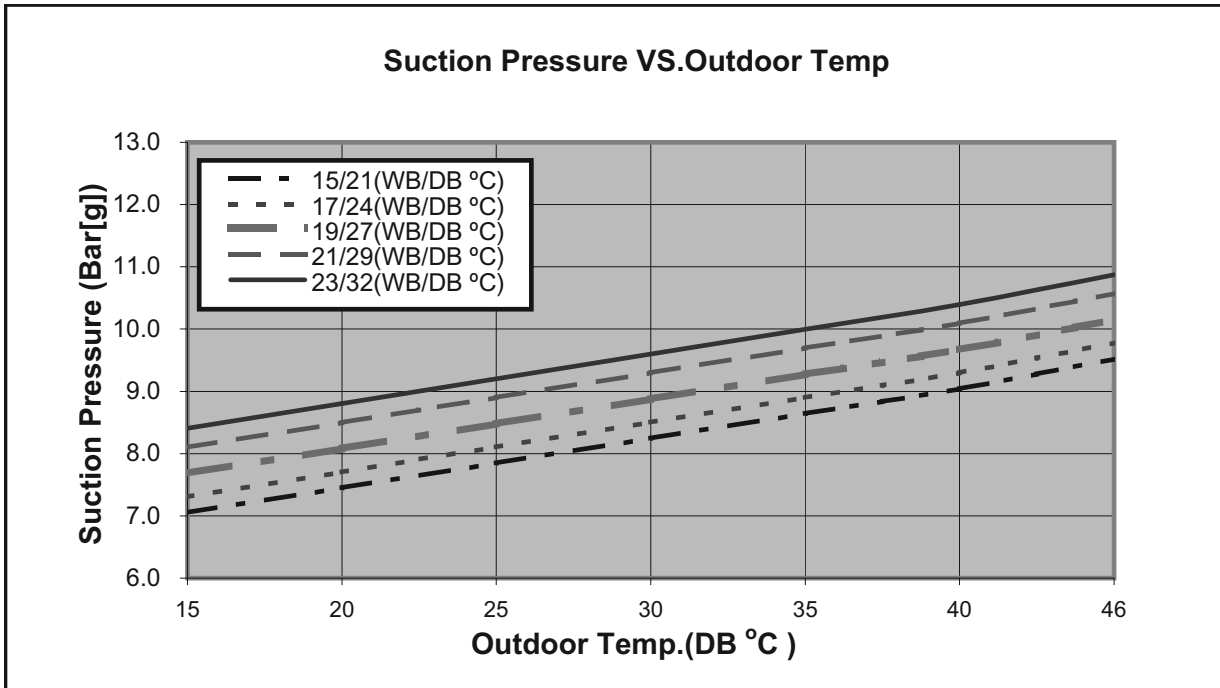
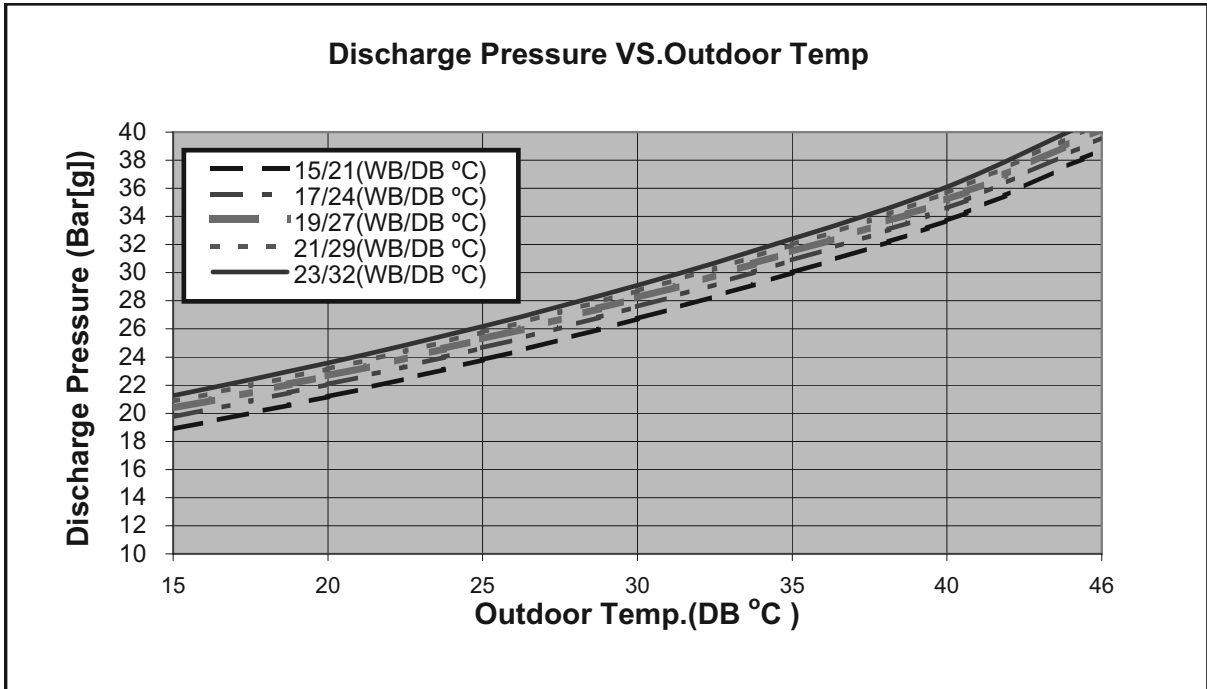

5.8.2 Heating.

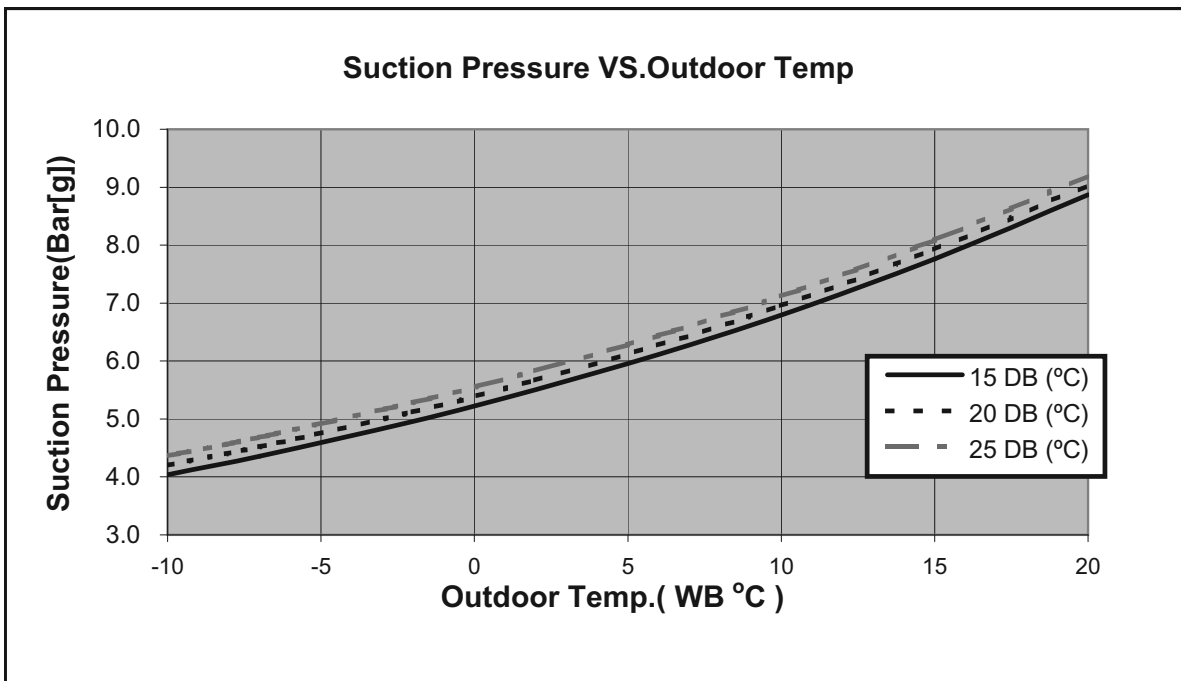
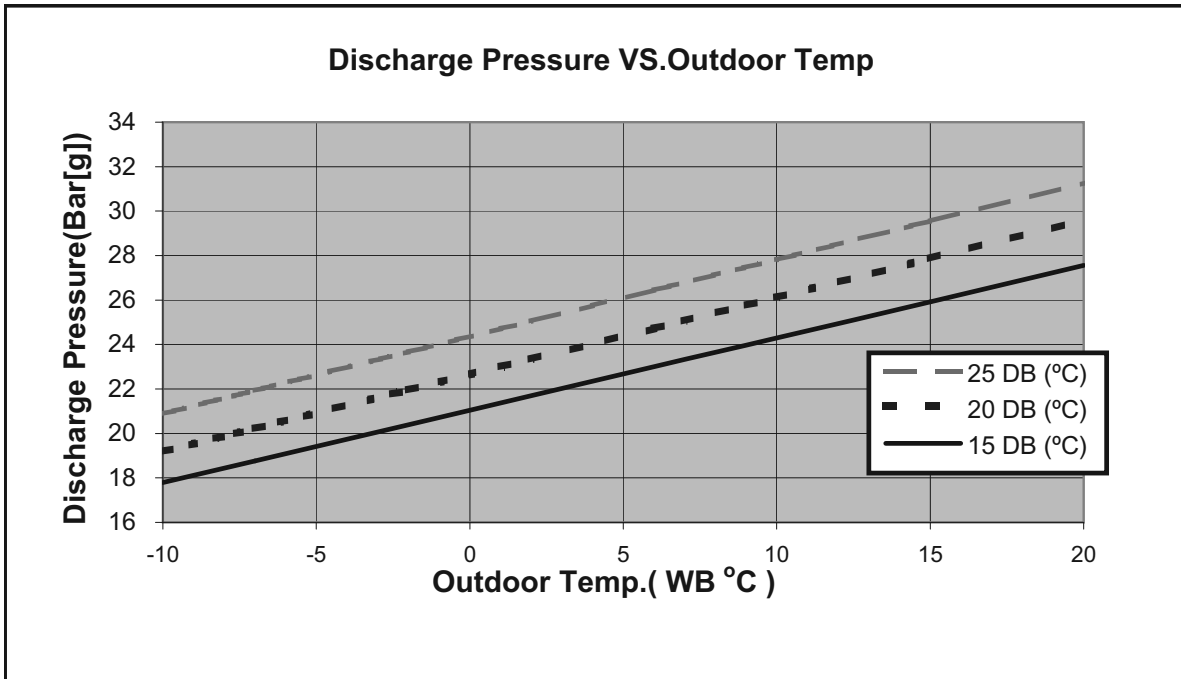

5.9 Model: Prime 9 / WAP9 R22

5.9.1 Cooling Mode at 7.5m Tubing Connection.

230V : Indoor Fan at High Speed.

Entering Air DB OD Coil(°C)	Data	Entering Air WB/DB ID Coil(°C)				
		15/21	17/24	19/27	21/29	23/32
15	TC	2.79	2.89	2.96	3.03	3.08
	SC	1.87	1.95	2.03	2.08	2.12
	PI	0.67	0.67	0.67	0.67	0.67
20	TC	2.70	2.85	2.94	3.01	3.07
	SC	1.83	1.93	2.01	2.07	2.11
	PI	0.72	0.73	0.73	0.73	0.73
25	TC	2.56	2.76	2.90	2.99	3.06
	SC	1.79	1.90	2.00	2.06	2.09
	PI	0.78	0.79	0.79	0.80	0.80
30	TC	2.39	2.60	2.81	2.91	3.00
	SC	1.73	1.84	1.96	2.01	2.05
	PI	0.84	0.86	0.86	0.87	0.88
35	TC	2.21	2.40	2.65	2.78	2.91
	SC	1.65	1.76	1.91	1.97	2.00
	PI	0.91	0.93	0.94	0.95	0.95
40	TC	2.01	2.19	2.39	2.61	2.75
	SC	1.55	1.67	1.81	1.86	1.90
	PI	0.98	1.00	1.01	1.03	1.04
46	TC	1.75	1.91	2.10	2.32	2.50
	SC	1.43	1.53	1.65	1.70	1.74
	PI	1.07	1.09	1.11	1.13	1.14

LEGEND

- TC – Total Cooling Capacity, kWv
- SC – Sensible Capacity, kW
- PI – Power Input, kW
- WB – Wet Bulb Temp., (°C)
- DB – Dry Bulb Temp., (°C)
- ID – Indoor
- OD – Outdoor

(1) Marked area is below standard operating limits. For operating in low ambient conditions, refer to Optional Accessories (Chapter 15).

5.9.2 Heating

ENTERING WB OD COIL(°C)	ENTERING AIR DB ID COIL(°C)					
	15		20		25	
	TH	PI	TH	PI	TH	PI
-10	1.52	0.68	1.46	0.72	1.40	0.76
-7	1.63	0.70	1.58	0.74	1.52	0.78
-2	1.73	0.71	1.68	0.75	1.62	0.79
2	2.11	0.74	2.02	0.79	1.94	0.83
6	2.98	0.79	2.89	0.85	2.79	0.90
10	3.24	0.84	3.15	0.90	3.06	0.96
15	3.50	0.88	3.41	0.94	3.32	1.00
20	3.68	0.90	3.60	0.98	3.50	1.05

LEGEND

- TH – Total Heating Capacity, kW
- PI – Power Input, kW
- WB – Wet Bulb Temp., (°C)
- DB – Dry Bulb Temp., (°C)
- ID – Indoor
- OU – Outdoor

5.10. Model: Prime 9 / WAP9 R22

5.10.1 Cooling

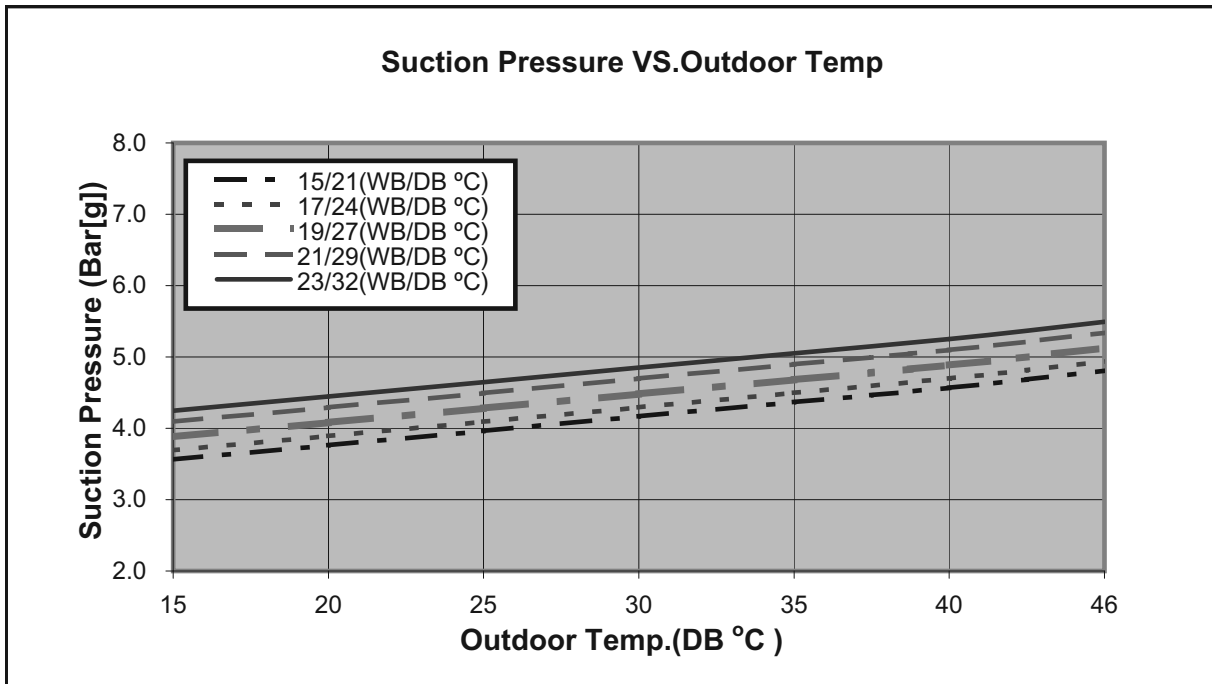
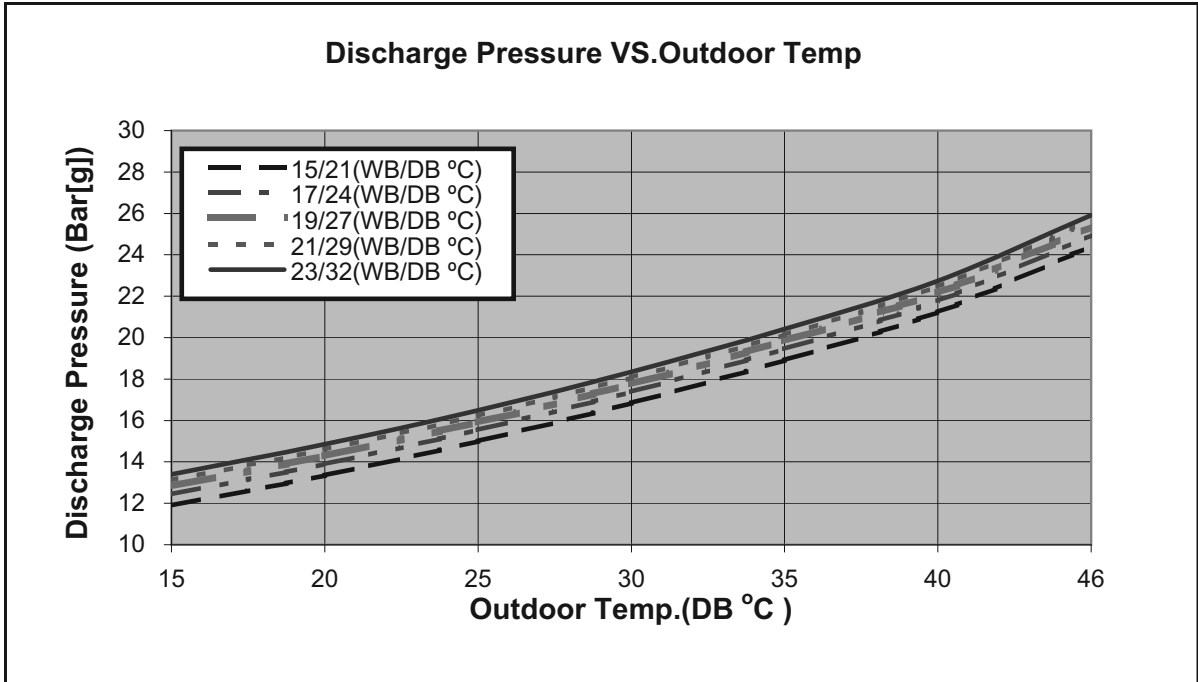

5.10.2 Heating.

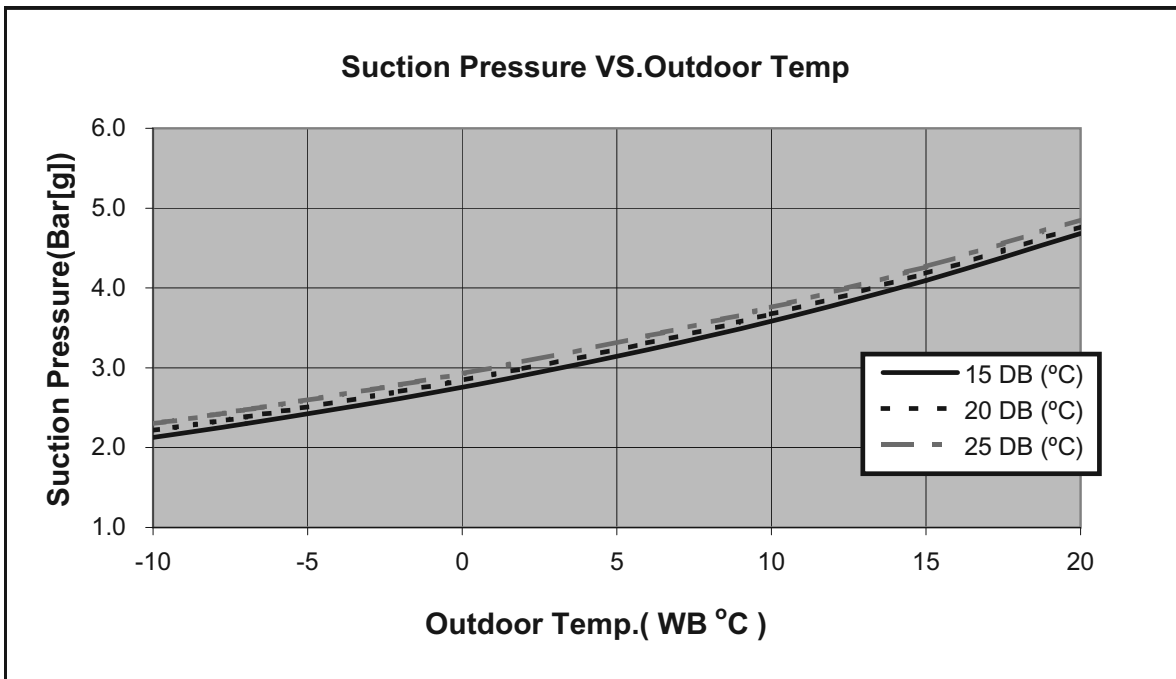
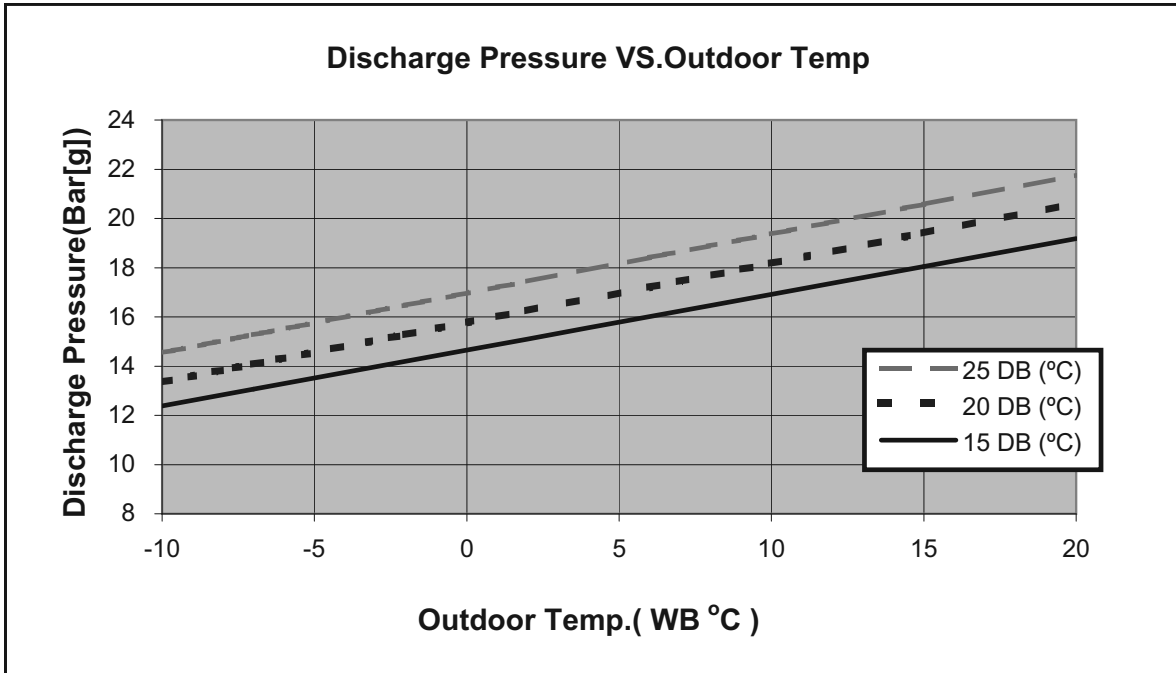

5.11 Model: Prime 12 / GCN12 R410A

5.11.1 Cooling Mode at 7.5m Tubing Connection.

230V : Indoor Fan at High Speed.

Entering Air DB OD Coil(°C)	Data	Entering Air WB/DB ID Coil(°C)				
		15/21	17/24	19/27	21/29	23/32
15	TC	3.79	3.93	4.02	4.12	4.18
	SC	2.47	2.57	2.67	2.74	2.79
	PI	0.79	0.80	0.80	0.80	0.80
20	TC	3.67	3.87	3.99	4.09	4.17
	SC	2.42	2.55	2.66	2.73	2.78
	PI	0.86	0.87	0.87	0.87	0.87
25	TC	3.47	3.75	3.94	4.06	4.16
	SC	2.36	2.50	2.64	2.71	2.76
	PI	0.93	0.94	0.94	0.95	0.96
30	TC	3.25	3.54	3.82	3.96	4.07
	SC	2.28	2.43	2.58	2.66	2.71
	PI	1.01	1.02	1.03	1.04	1.05
35	TC	3.01	3.26	3.60	3.78	3.96
	SC	2.17	2.33	2.52	2.59	2.64
	PI	1.08	1.10	1.12	1.13	1.13
40	TC	2.73	2.98	3.25	3.55	3.74
	SC	2.05	2.20	2.38	2.46	2.51
	PI	1.17	1.19	1.21	1.22	1.23
46	TC	2.37	2.59	2.85	3.15	3.40
	SC	1.88	2.02	2.17	2.25	2.30
	PI	1.28	1.30	1.33	1.35	1.36

LEGEND

- TC – Total Cooling Capacity, kWv
- SC – Sensible Capacity, kW
- PI – Power Input, kW
- WB – Wet Bulb Temp., (°C)
- DB – Dry Bulb Temp., (°C)
- ID – Indoor
- OD – Outdoor

(1) Marked area is below standard operating limits. For operating in low ambient conditions, refer to Optional Accessories (Chapter 15).

5.11.2 Heating

ENTERING WB OD COIL(°C)	ENTERING AIR DB ID COIL(°C)					
	15		20		25	
	TH	PI	TH	PI	TH	PI
-10	2.01	0.89	1.93	0.95	1.85	0.99
-7	2.16	0.91	2.08	0.96	2.01	1.01
-2	2.29	0.92	2.22	0.98	2.14	1.03
2	2.79	0.97	2.67	1.03	2.56	1.09
6	3.93	1.04	3.82	1.11	3.69	1.18
10	4.28	1.10	4.16	1.17	4.05	1.25
15	4.62	1.14	4.51	1.23	4.39	1.31
20	4.87	1.18	4.76	1.28	4.62	1.38

LEGEND

- TH – Total Heating Capacity, kW
- PI – Power Input, kW
- WB – Wet Bulb Temp., (°C)
- DB – Dry Bulb Temp., (°C)
- ID – Indoor
- OU – Outdoor

5.12. Model: Prime 12 / GCN12 R410A

5.12.1 Cooling

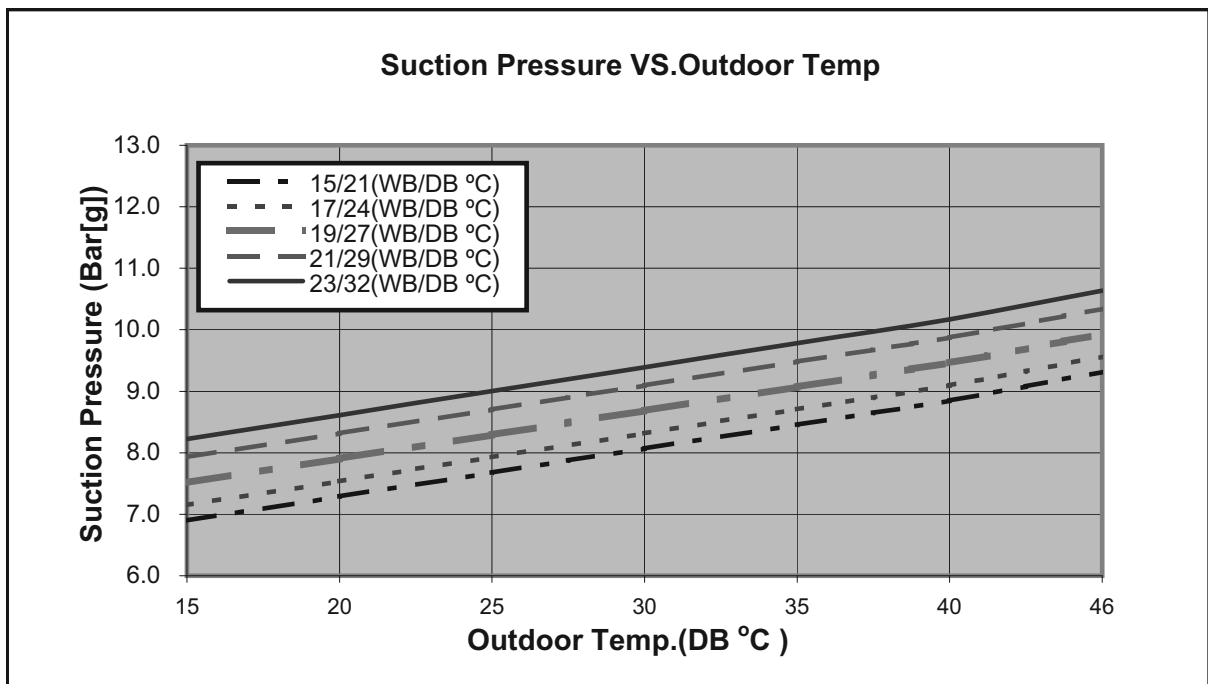
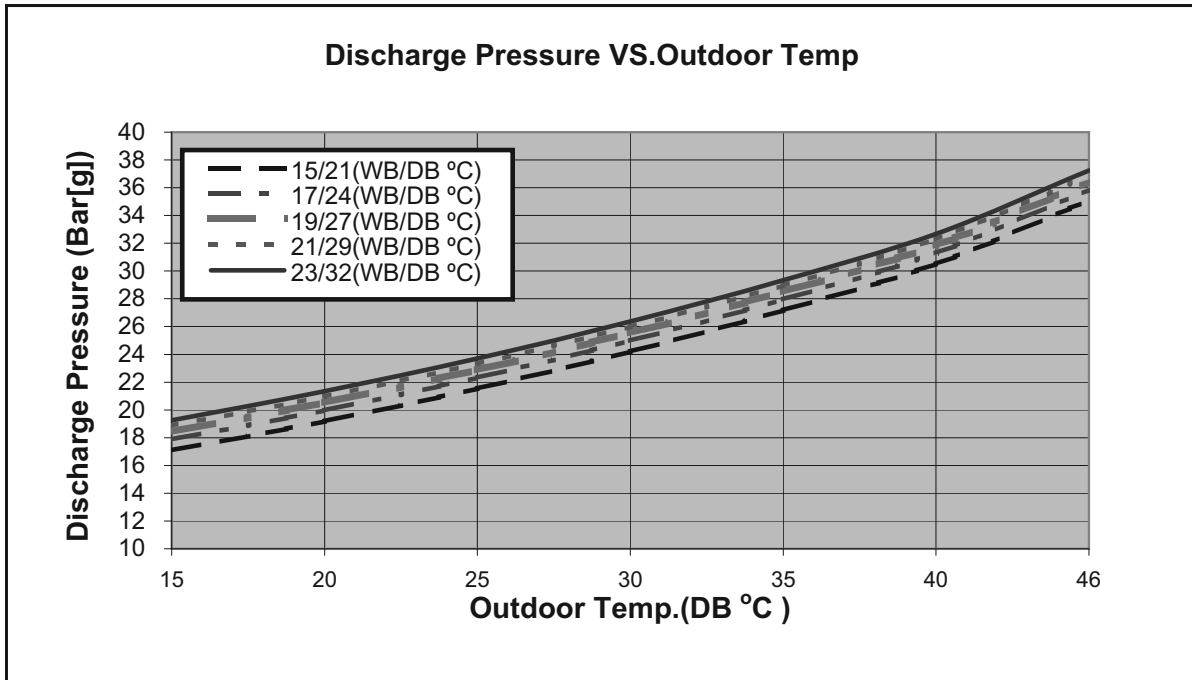

5.12.2 Heating.

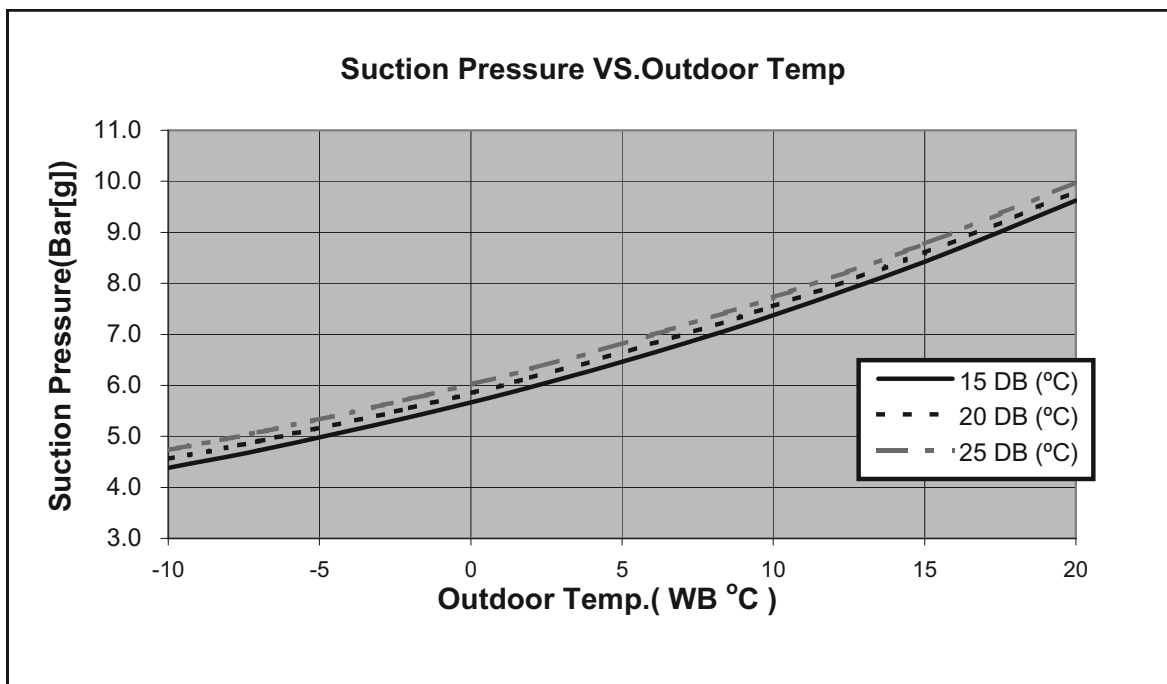
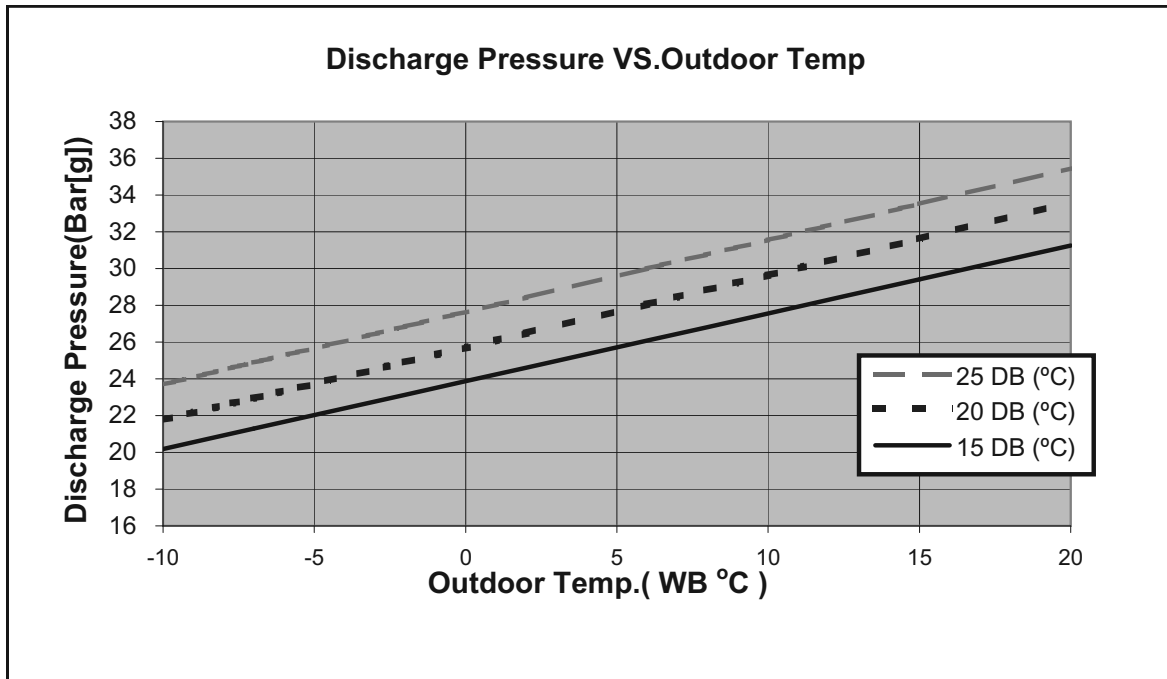

5.13 Prime 12 / WAP12 R410

5.13.1. Cooling Mode at 7.5m Tubing Connection

230V : Indoor Fan at High Speed.

Entering Air DB OD Coil(°C)	Data	Entering Air WB/DB ID Coil(°C)				
		15/21	17/24	19/27	21/29	23/32
15	TC	3.48	3.60	3.69	3.77	3.83
	SC	2.53	2.64	2.74	2.81	2.86
	PI	0.82	0.82	0.83	0.83	0.83
20	TC	3.37	3.55	3.66	3.75	3.83
	SC	2.48	2.61	2.72	2.80	2.85
	PI	0.89	0.90	0.90	0.90	0.91
25	TC	3.18	3.44	3.61	3.72	3.81
	SC	2.41	2.56	2.70	2.78	2.83
	PI	0.97	0.97	0.98	0.98	0.99
30	TC	2.98	3.24	3.50	3.63	3.73
	SC	2.34	2.48	2.64	2.72	2.77
	PI	1.04	1.06	1.07	1.07	1.08
35	TC	2.76	2.99	3.30	3.47	3.63
	SC	2.22	2.38	2.58	2.65	2.71
	PI	1.12	1.14	1.16	1.17	1.18
40	TC	2.51	2.73	2.98	3.26	3.42
	SC	2.09	2.25	2.44	2.52	2.57
	PI	1.21	1.23	1.25	1.27	1.28
46	TC	2.18	2.38	2.62	2.89	3.11
	SC	1.93	2.07	2.23	2.30	2.35
	PI	1.32	1.34	1.37	1.39	1.41

LEGEND

- TC – Total Cooling Capacity, kWv
- SC – Sensible Capacity, kW
- PI – Power Input, kW
- WB – Wet Bulb Temp., (°C)
- DB – Dry Bulb Temp., (°C)
- ID – Indoor
- OD – Outdoor

(1) Marked area is below standard operating limits. For operating in low ambient conditions, refer to Optional Accessories (Chapter 15)

5.13.2 Heating.

ENTERING WB OD COIL(°C)	ENTERING AIR DB ID COIL(°C)					
	15		20		25	
	TH	PI	TH	PI	TH	PI
-10	1.79	0.84	1.72	0.89	1.65	0.94
-7	1.92	0.86	1.85	0.91	1.79	0.96
-2	2.04	0.87	1.97	0.92	1.90	0.98
2	2.48	0.91	2.38	0.97	2.28	1.03
6	3.50	0.98	3.40	1.05	3.28	1.12
10	3.81	1.04	3.71	1.11	3.60	1.18
15	4.11	1.08	4.01	1.17	3.91	1.24
20	4.34	1.11	4.23	1.21	4.11	1.30

LEGEND

- TH – Total Heating Capacity, kW
- PI – Power Input, kW
- WB – Wet Bulb Temp., (°C)
- DB – Dry Bulb Temp., (°C)
- ID – Indoor
- OU – Outdoor

5.14 Prime 12 / WAP12 R410.

5.14.1 Cooling

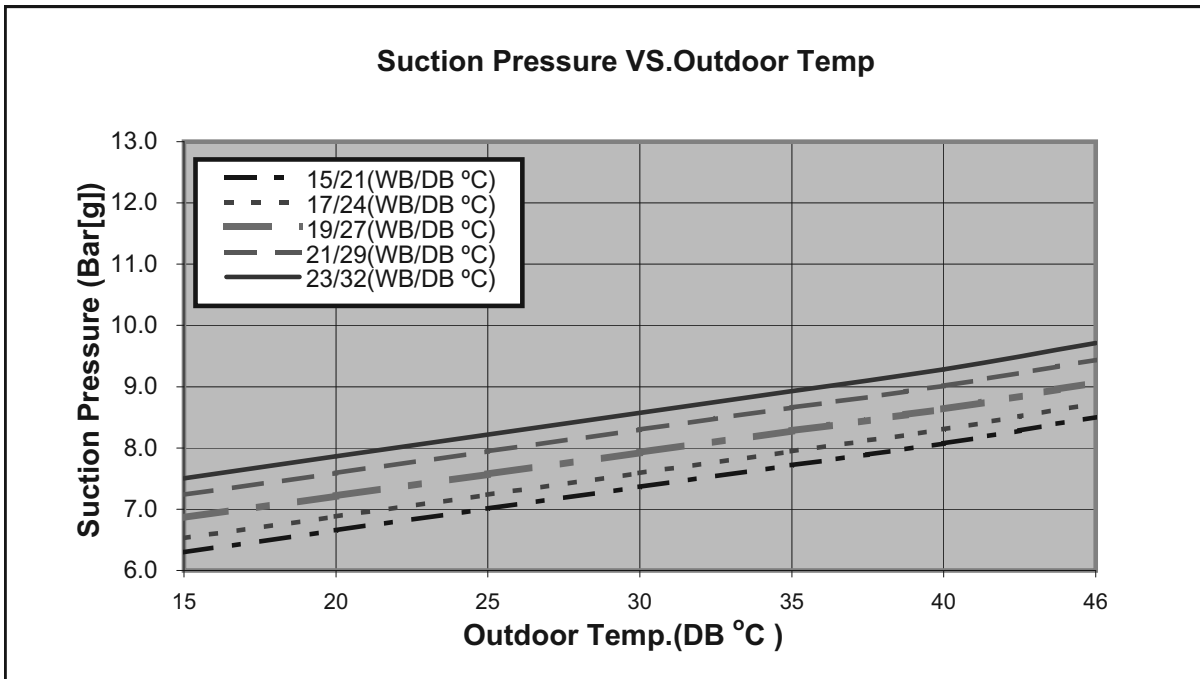
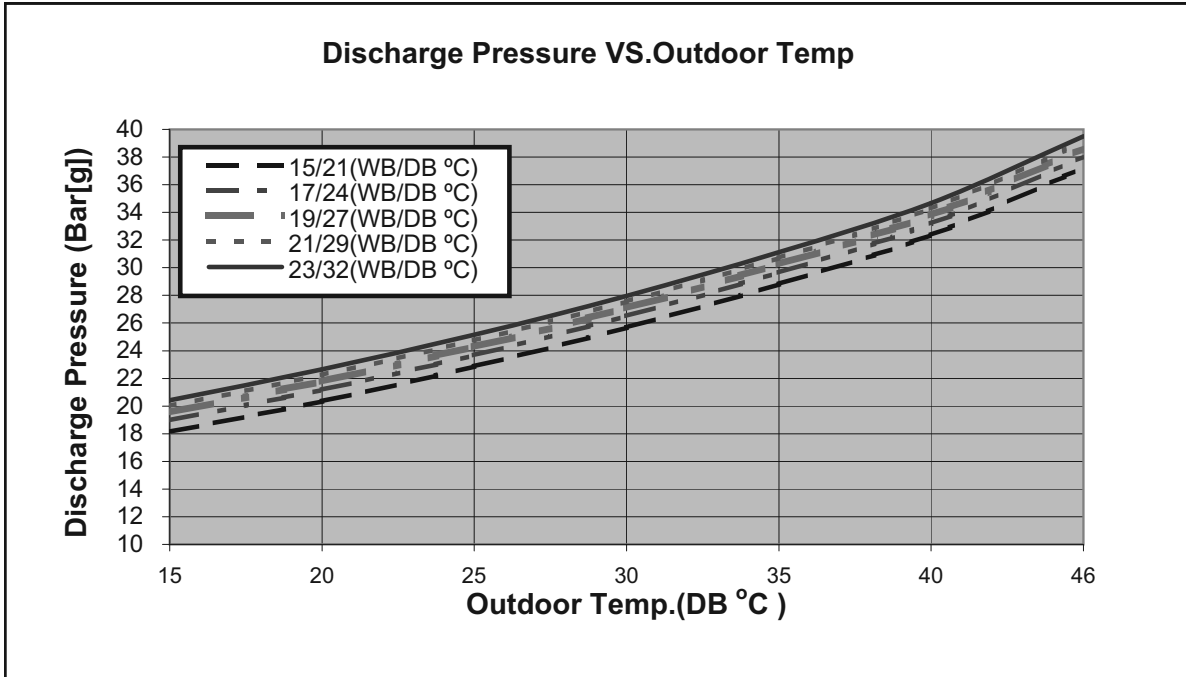

5.14.2 Heating.

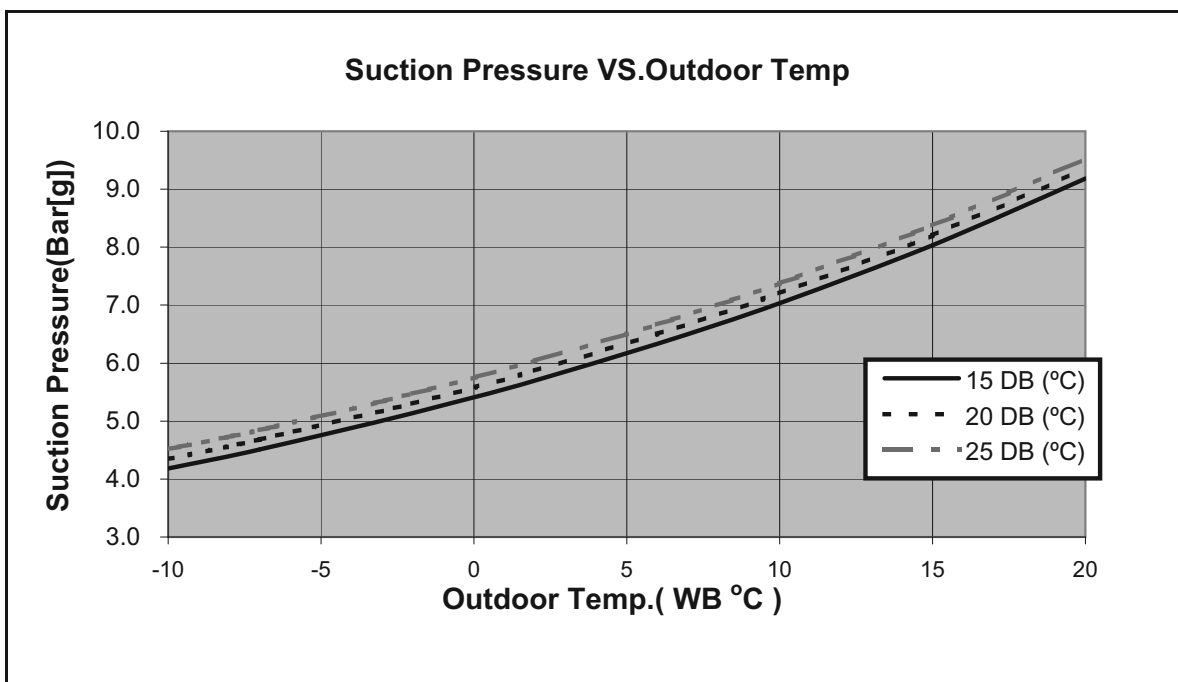
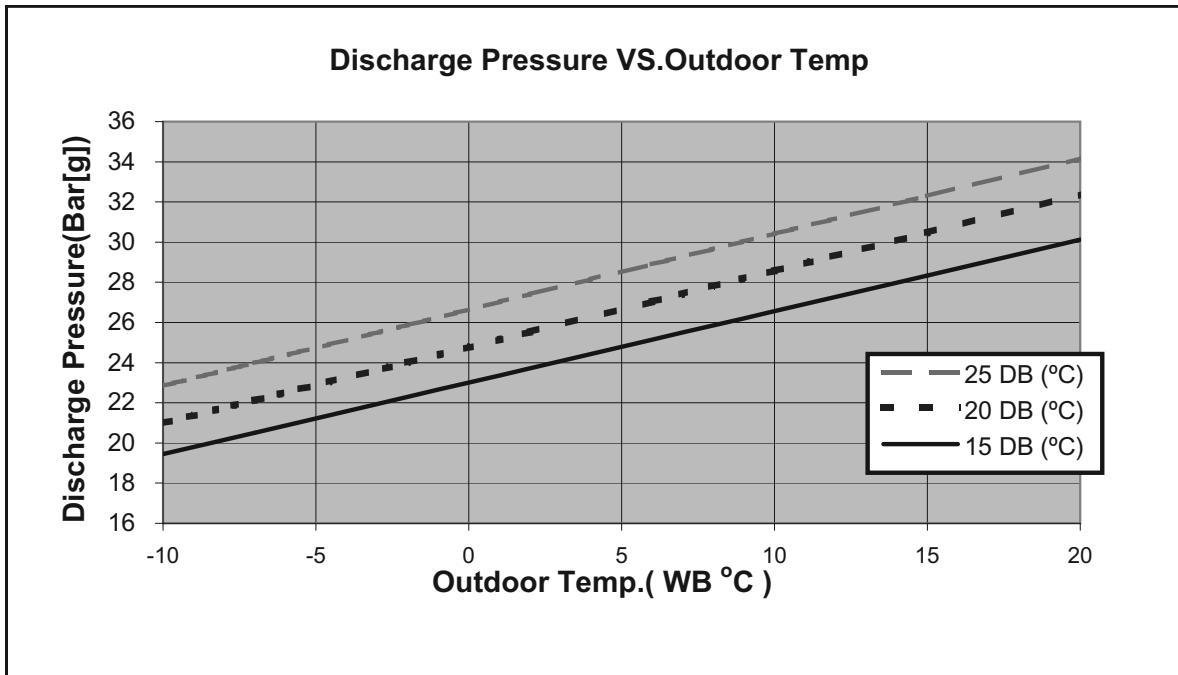

5.15 Model: Prime 12 / WAP12 R22.

5.15.1 Cooling Mode at 7.5m Tubing Connection

230V : Indoor Fan at High Speed

Entering Air DB OD Coil(°C)	Data	Entering Air WB/DB ID Coil(°C)				
		15/21	17/24	19/27	21/29	23/32
15	TC	3.48	3.60	3.69	3.77	3.83
	SC	2.18	2.28	2.37	2.43	2.47
	PI	0.83	0.83	0.83	0.83	0.84
20	TC	3.37	3.55	3.66	3.75	3.83
	SC	2.14	2.26	2.35	2.42	2.46
	PI	0.90	0.90	0.91	0.91	0.91
25	TC	3.18	3.44	3.61	3.72	3.81
	SC	2.09	2.21	2.33	2.40	2.45
	PI	0.97	0.98	0.99	0.99	1.00
30	TC	2.98	3.24	3.50	3.63	3.73
	SC	2.02	2.15	2.28	2.35	2.39
	PI	1.05	1.07	1.07	1.08	1.09
35	TC	2.76	2.99	3.30	3.47	3.63
	SC	1.92	2.06	2.23	2.29	2.34
	PI	1.13	1.15	1.17	1.18	1.19
40	TC	2.51	2.73	2.98	3.26	3.42
	SC	1.81	1.95	2.11	2.18	2.22
	PI	1.22	1.24	1.26	1.28	1.29
46	TC	2.18	2.38	2.62	2.89	3.11
	SC	1.67	1.79	1.92	1.99	2.04
	PI	1.33	1.35	1.39	1.41	1.42

LEGEND

- TC – Total Cooling Capacity, kWv
- SC – Sensible Capacity, kW
- PI – Power Input, kW
- WB – Wet Bulb Temp., (°C)
- DB – Dry Bulb Temp., (°C)
- ID – Indoor
- OD – Outdoor

(1) Marked area is below standard operating limits. For operating in low ambient conditions, refer to Optional Accessories (Chapter 15)

5.15.2 Heating.

ENTERING WB OD COIL(°C)	ENTERING AIR DB ID COIL(°C)					
	15		20		25	
	TH	PI	TH	PI	TH	PI
-10	1.97	0.84	1.89	0.89	1.82	0.94
-7	2.12	0.86	2.04	0.91	1.97	0.96
-2	2.25	0.87	2.18	0.92	2.10	0.98
2	2.74	0.91	2.63	0.97	2.51	1.03
6	3.86	0.98	3.75	1.05	3.62	1.12
10	4.20	1.04	4.09	1.11	3.98	1.18
15	4.54	1.08	4.43	1.17	4.31	1.24
20	4.78	1.11	4.67	1.21	4.54	1.30

LEGEND

- TH – Total Heating Capacity, kW
- PI – Power Input, kW
- WB – Wet Bulb Temp., (°C)
- DB – Dry Bulb Temp., (°C)
- ID – Indoor
- OU – Outdoor

5.16 Model: Prime 12 / WAP12 R22.

5.16.1 Cooling

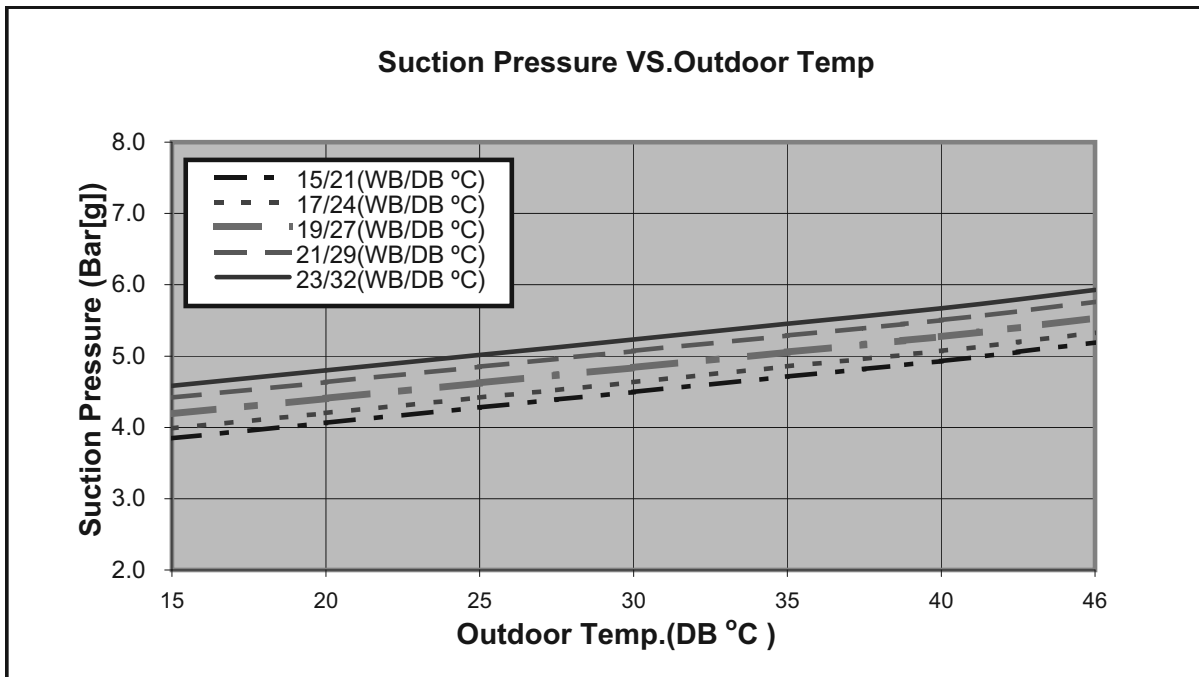
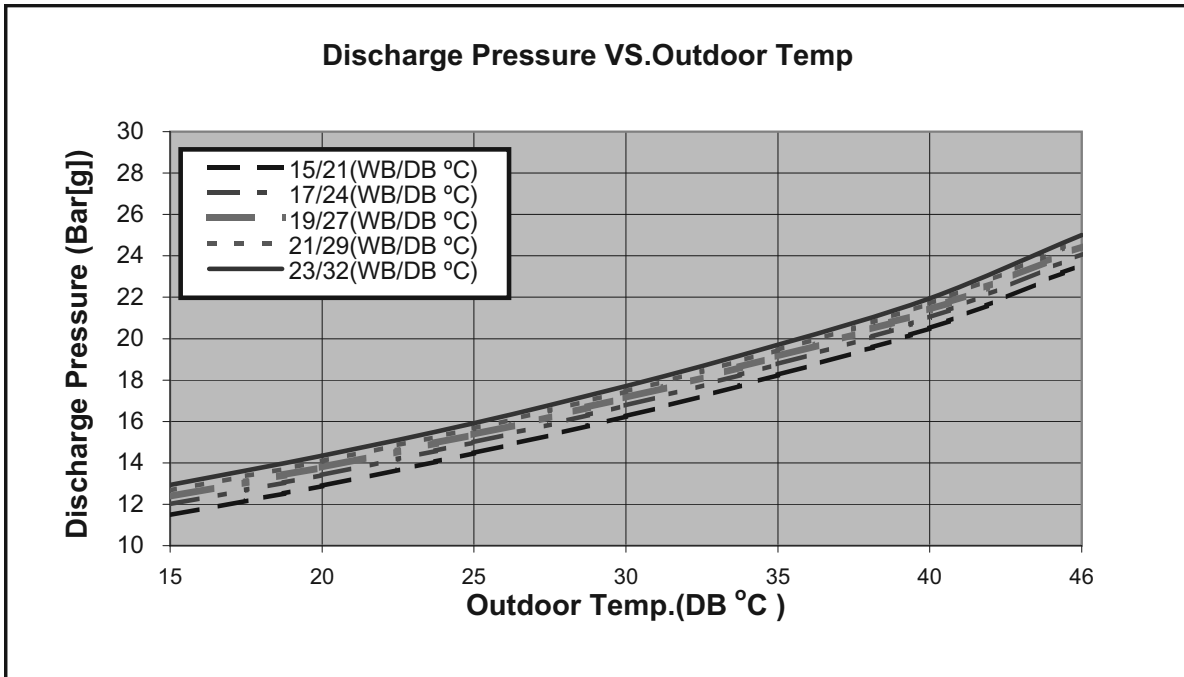

5.16.2 Heating.

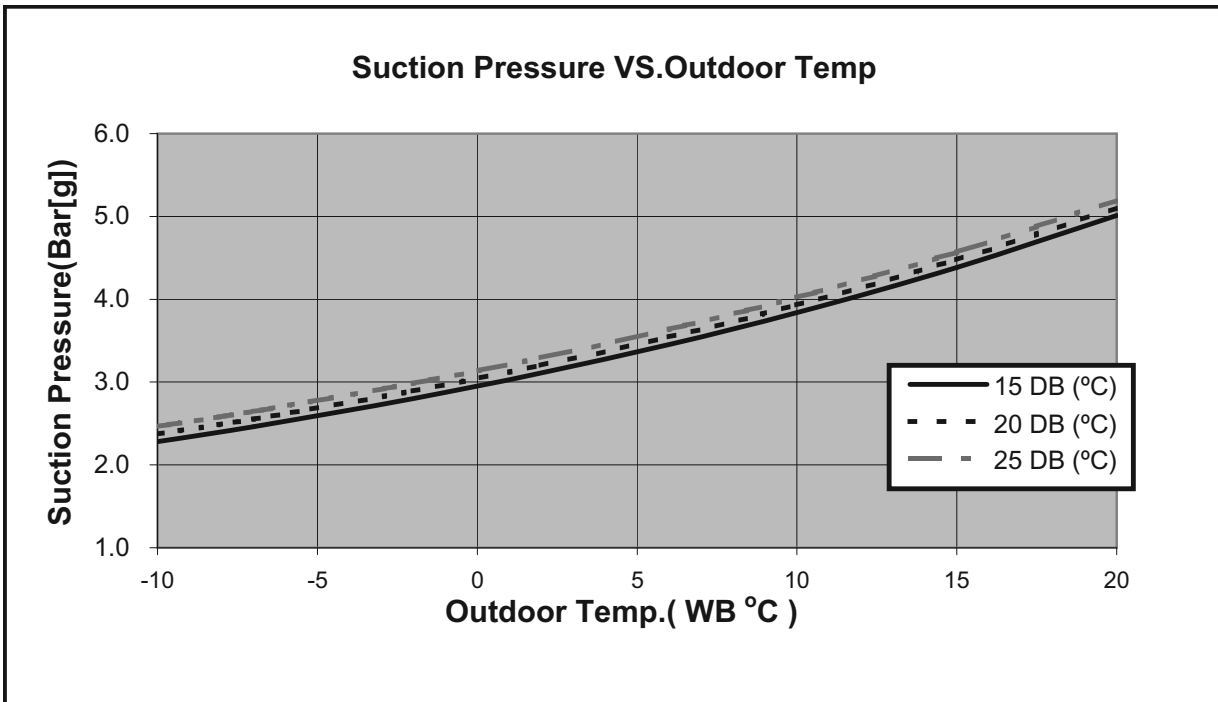
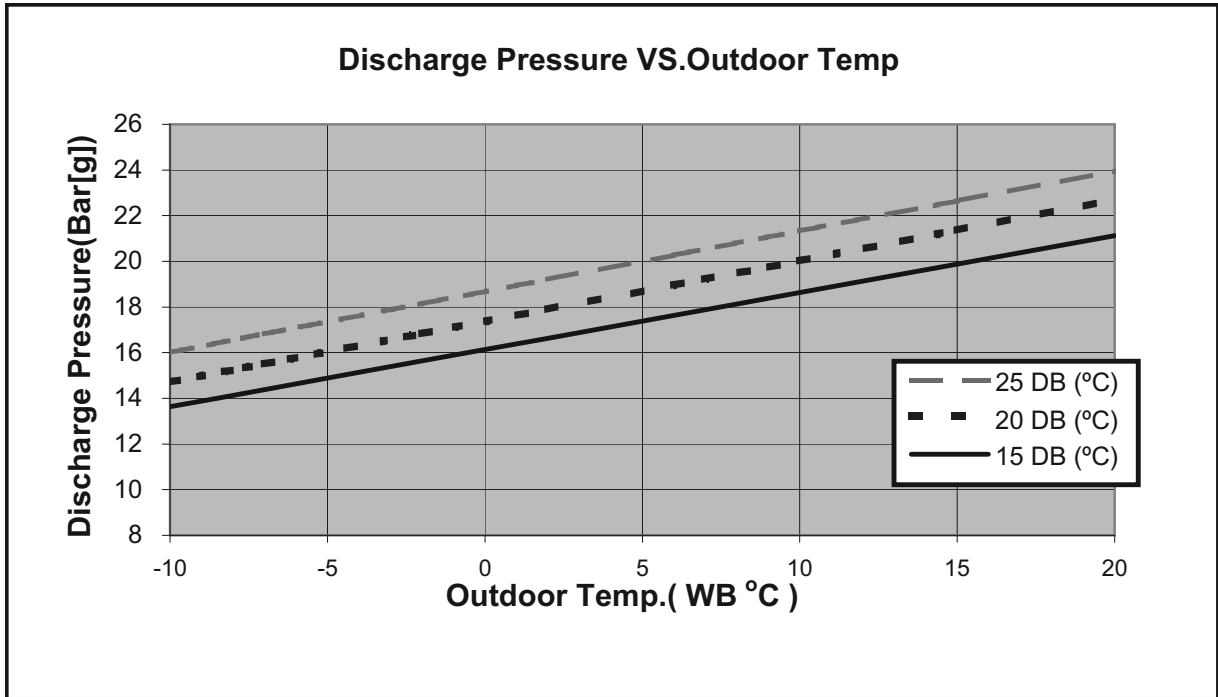

5.17 Model: Prime 18 / GCN17 NRC R410

5.17.1 Cooling Mode at 7.5m Tubing Connection

230V : Indoor Fan at High Speed

Entering Air DB OD Coil(°C)	Data	Entering Air WB/DB ID Coil(°C)				
		15/21	17/24	19/27	21/29	23/32
15	TC	5.80	6.00	6.15	6.29	6.39
	SC	3.81	3.97	4.13	4.23	4.31
	PI	1.18	1.18	1.18	1.18	1.19
20	TC	5.61	5.91	6.10	6.24	6.38
	SC	3.73	3.94	4.10	4.22	4.30
	PI	1.28	1.28	1.29	1.29	1.30
25	TC	5.31	5.73	6.02	6.21	6.36
	SC	3.64	3.86	4.07	4.19	4.27
	PI	1.38	1.39	1.40	1.41	1.42
30	TC	4.96	5.40	5.84	6.05	6.22
	SC	3.52	3.75	3.98	4.10	4.18
	PI	1.49	1.51	1.52	1.54	1.55
35	TC	4.59	4.99	5.50	5.78	6.05
	SC	3.35	3.59	3.89	4.00	4.08
	PI	1.61	1.63	1.66	1.67	1.68
40	TC	4.18	4.55	4.96	5.43	5.71
	SC	3.16	3.40	3.68	3.80	3.87
	PI	1.73	1.76	1.79	1.81	1.83
46	TC	3.63	3.96	4.36	4.82	5.19
	SC	2.91	3.12	3.36	3.47	3.55
	PI	1.89	1.92	1.97	1.99	2.02

LEGEND

- TC – Total Cooling Capacity, kWv
- SC – Sensible Capacity, kW
- PI – Power Input, kW
- WB – Wet Bulb Temp., (°C)
- DB – Dry Bulb Temp., (°C)
- ID – Indoor
- OD – Outdoor

(1) Marked area is below standard operating limits. For operating in low ambient conditions, refer to Optional Accessories (Chapter 15).

5.17.2 Heating.

ENTERING WB OD COIL(°C)	ENTERING AIR DB ID COIL(°C)					
	15		20		25	
	TH	PI	TH	PI	TH	PI
-10	2.99	1.34	2.88	1.42	2.76	1.49
-7	3.22	1.37	3.11	1.44	2.99	1.52
-2	3.42	1.39	3.31	1.47	3.19	1.55
2	4.16	1.45	3.99	1.54	3.82	1.64
6	5.87	1.56	5.70	1.67	5.50	1.77
10	6.38	1.65	6.21	1.76	6.04	1.88
15	6.90	1.72	6.73	1.85	6.56	1.97
20	7.27	1.77	7.10	1.92	6.90	2.07

LEGEND

- TH – Total Heating Capacity, kW
- PI – Power Input, kW
- WB – Wet Bulb Temp., (°C)
- DB – Dry Bulb Temp., (°C)
- ID – Indoor
- OU – Outdoor

5.18 Model: Prime 18 / GCN17 NRC R410

5.18.1 Cooling

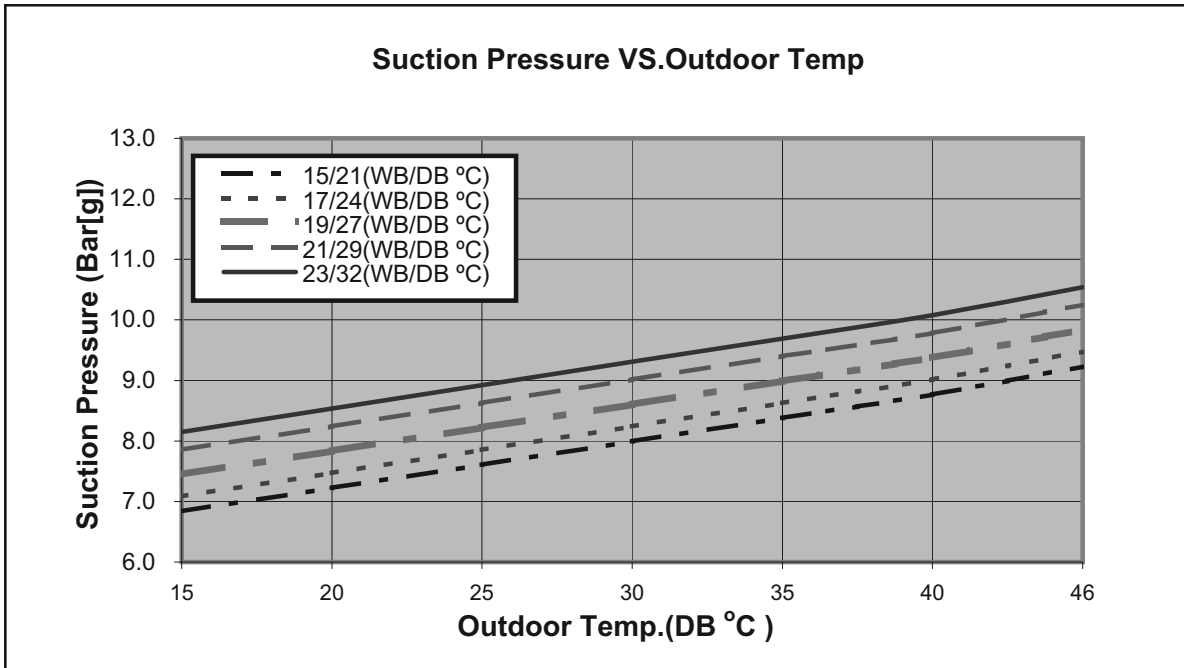
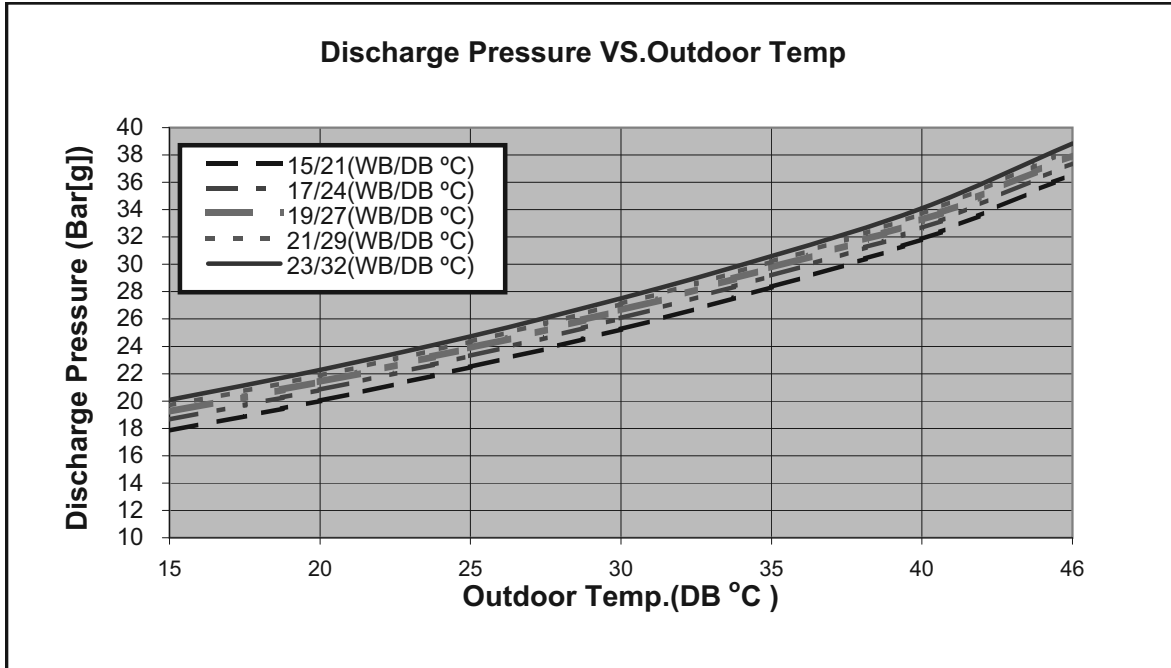

5.18.2 Heating.

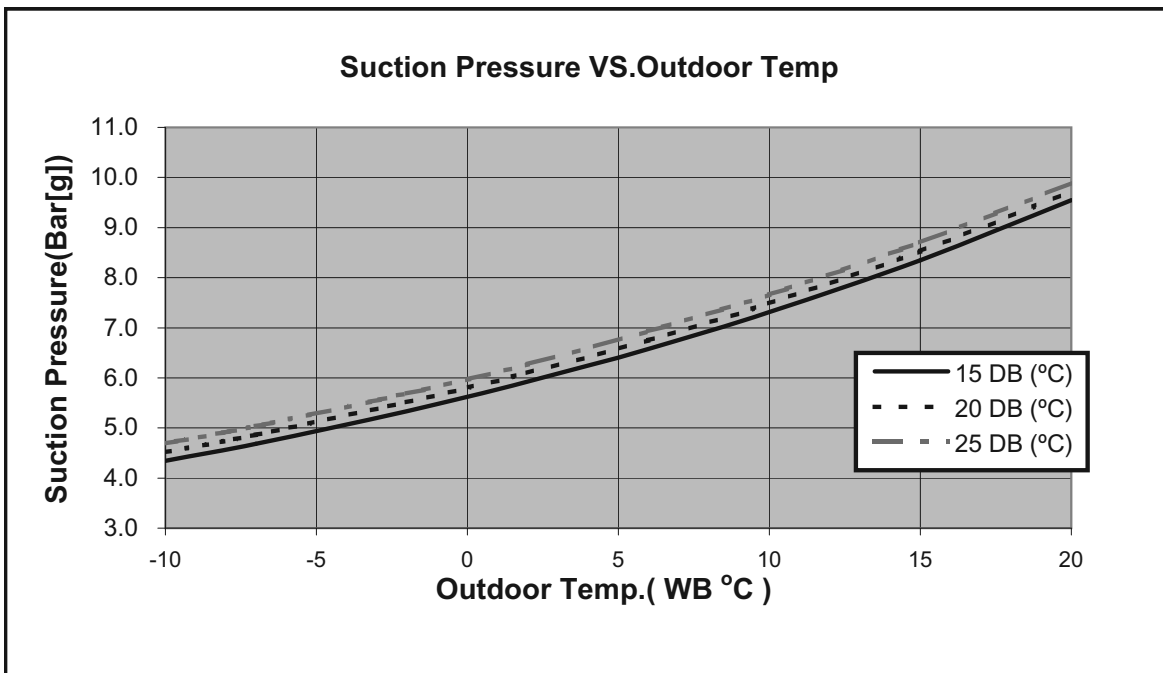
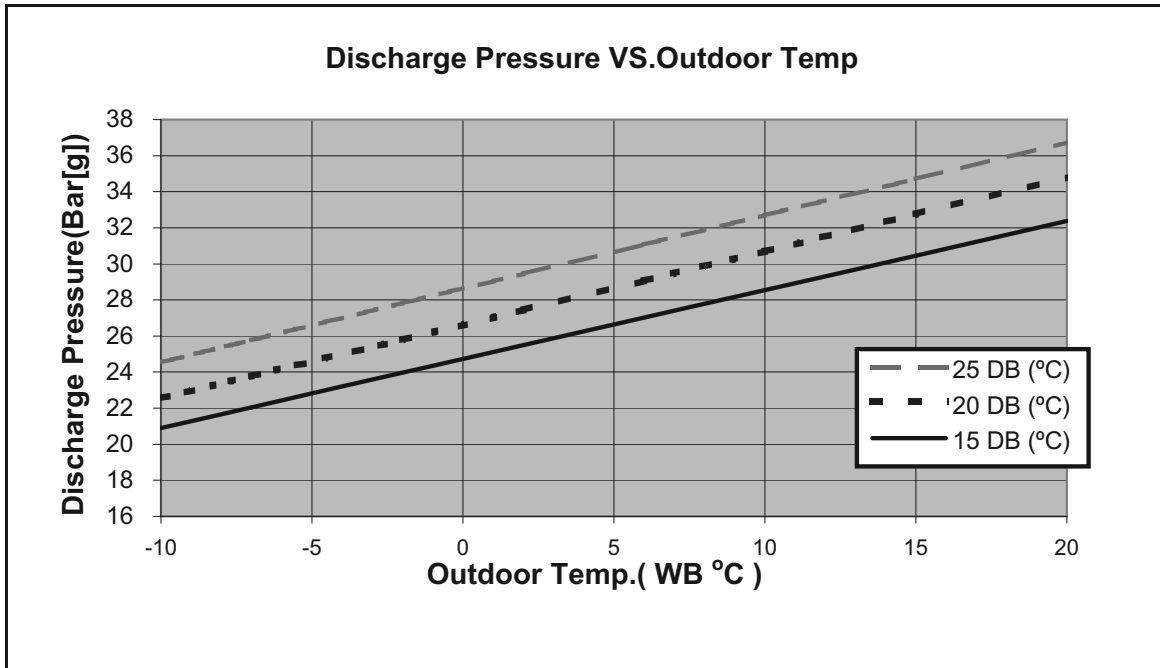

5.19 Model: Prime18 / RELAX17 NRC R22.

5.19.1 Cooling Mode at 7.5m Tubing Connection

230V : Indoor Fan at High Speed

Entering Air DB OD Coil(°C)	Data	Entering Air WB/DB ID Coil(°C)				
		15/21	17/24	19/27	21/29	23/32
15	TC	5.61	5.81	5.95	6.09	6.18
	SC	3.50	3.65	3.79	3.88	3.95
	PI	1.32	1.32	1.32	1.33	1.33
20	TC	5.43	5.72	5.90	6.04	6.17
	SC	3.43	3.61	3.77	3.87	3.94
	PI	1.43	1.44	1.44	1.45	1.45
25	TC	5.13	5.54	5.83	6.00	6.15
	SC	3.34	3.54	3.74	3.84	3.91
	PI	1.55	1.56	1.57	1.58	1.59
30	TC	4.80	5.23	5.65	5.85	6.02
	SC	3.23	3.44	3.65	3.76	3.83
	PI	1.67	1.69	1.71	1.72	1.74
35	TC	4.44	4.82	5.32	5.59	5.85
	SC	3.07	3.30	3.57	3.67	3.75
	PI	1.80	1.83	1.86	1.87	1.88
40	TC	4.04	4.40	4.80	5.25	5.52
	SC	2.90	3.12	3.38	3.48	3.56
	PI	1.94	1.97	2.01	2.03	2.05
46	TC	3.51	3.83	4.22	4.66	5.02
	SC	2.67	2.86	3.08	3.19	3.26
	PI	2.12	2.15	2.20	2.23	2.26

- TC – Total Cooling Capacity, kWv
- SC – Sensible Capacity, kW
- PI – Power Input, kW
- WB – Wet Bulb Temp., (°C)
- DB – Dry Bulb Temp., (°C)
- ID – Indoor
- OD – Outdoor

(1) Marked area is below standard operating limits. For operating in low ambient conditions, refer to Optional Accessories (Chapter 15).

5.19.2 Heating

ENTERING WB OD COIL(°C)	ENTERING AIR DB ID COIL(°C)					
	15		20		25	
	TH	PI	TH	PI	TH	PI
-10	2.94	1.43	2.83	1.53	2.72	1.60
-7	3.16	1.47	3.05	1.55	2.94	1.63
-2	3.36	1.49	3.25	1.58	3.14	1.66
2	4.09	1.56	3.92	1.66	3.75	1.75
6	5.77	1.67	5.60	1.79	5.40	1.90
10	6.27	1.77	6.10	1.89	5.94	2.02
15	6.78	1.84	6.61	1.99	6.44	2.11
20	7.14	1.90	6.97	2.06	6.78	2.22

LEGEND

- TH – Total Heating Capacity, kW
- PI – Power Input, kW
- WB – Wet Bulb Temp., (°C)
- DB – Dry Bulb Temp., (°C)
- ID – Indoor
- OU – Outdoor

5.20 Model: Prime18 / RELAX17 NRC R22

5.20.1 Cooling

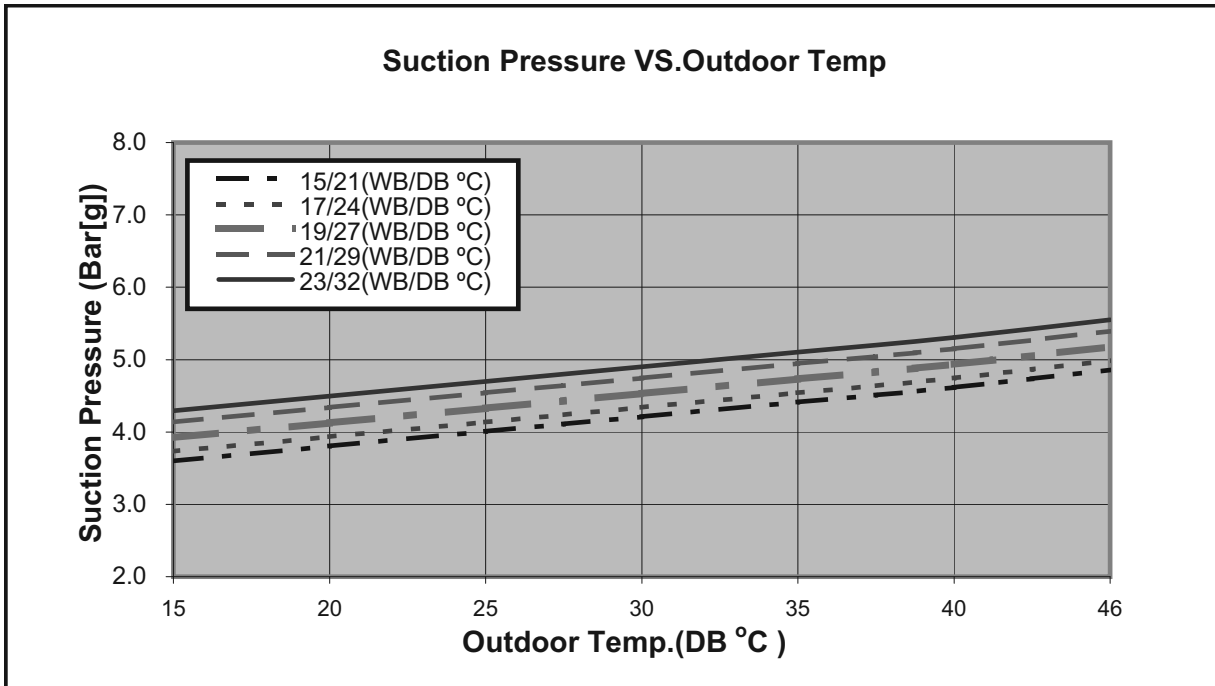
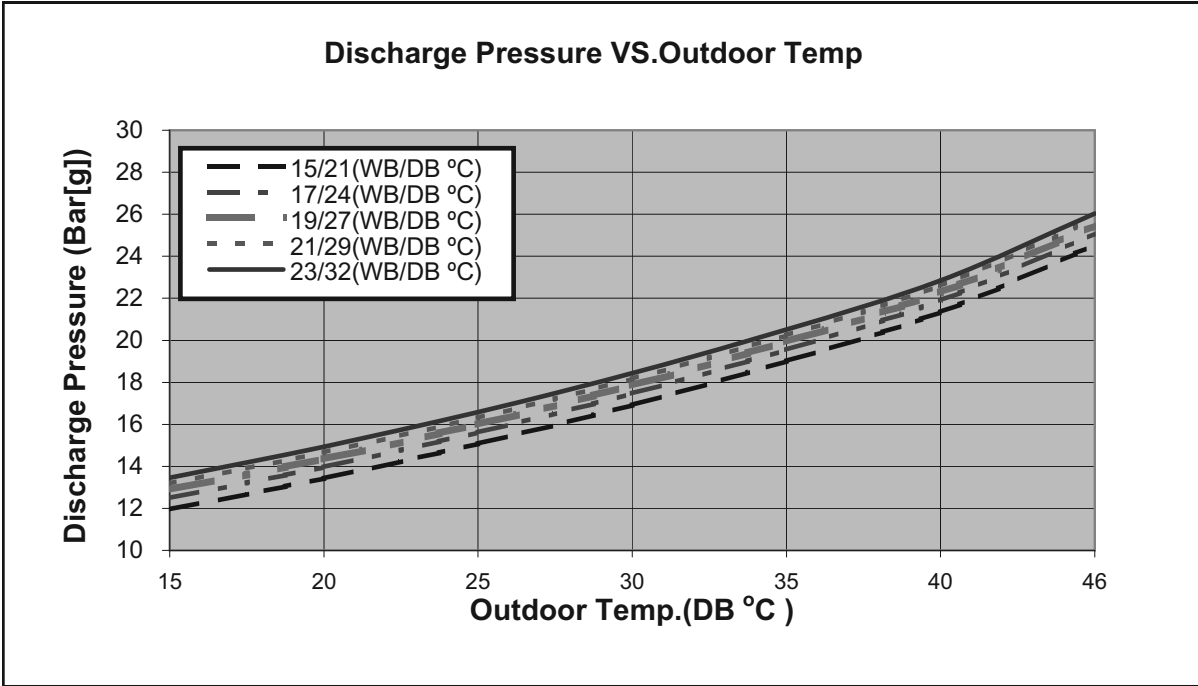

5.20.2 Heating.

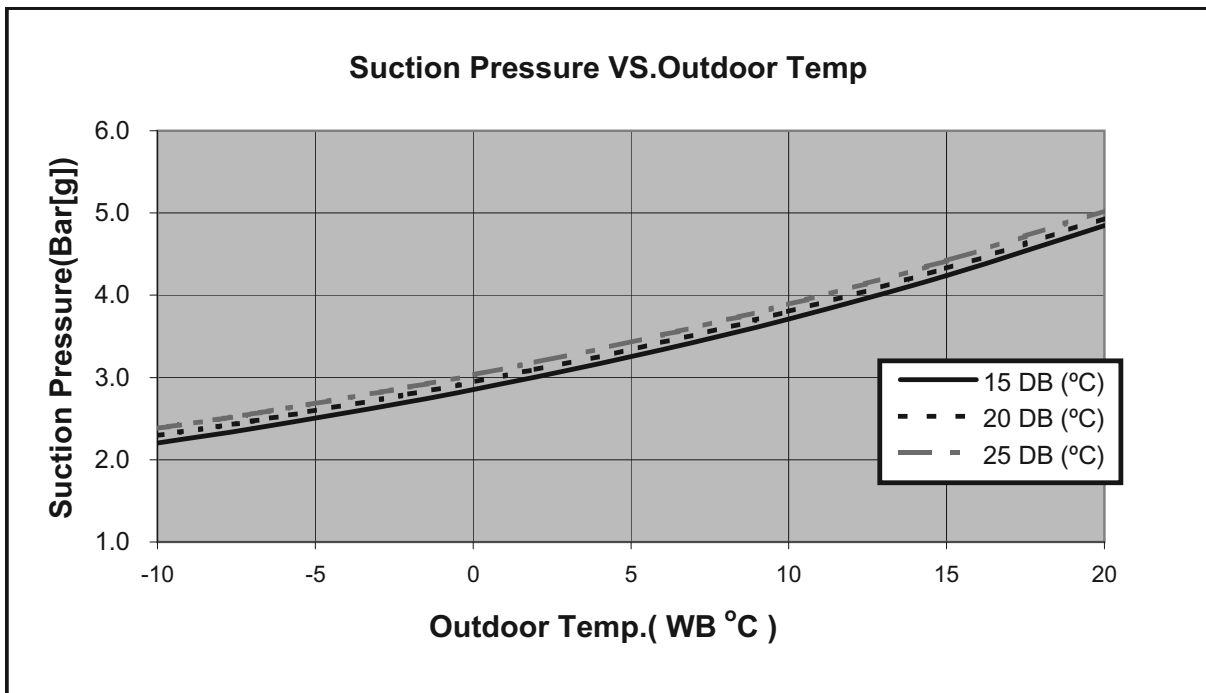
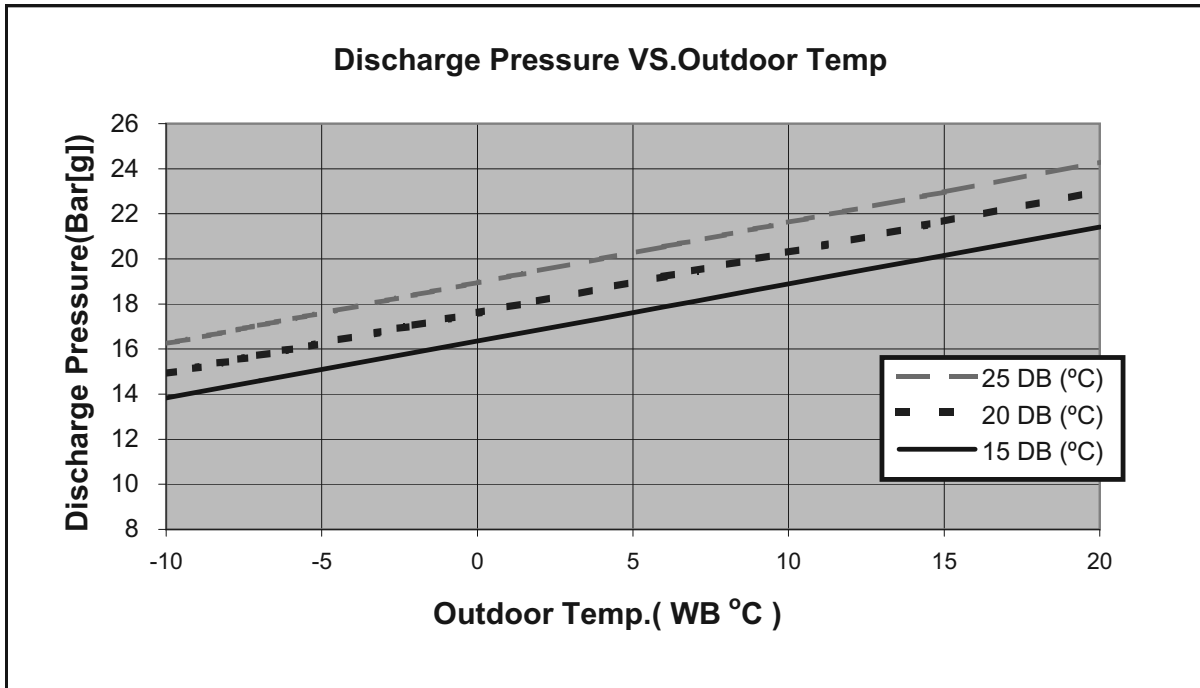

6. SOUND LEVEL CHARACTERISTICS

6.1 Sound Pressure Level

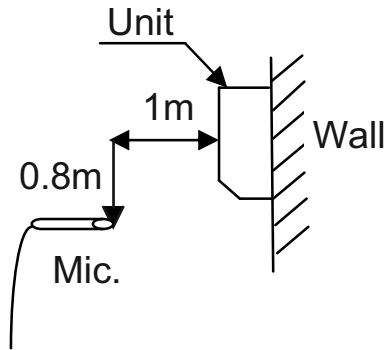
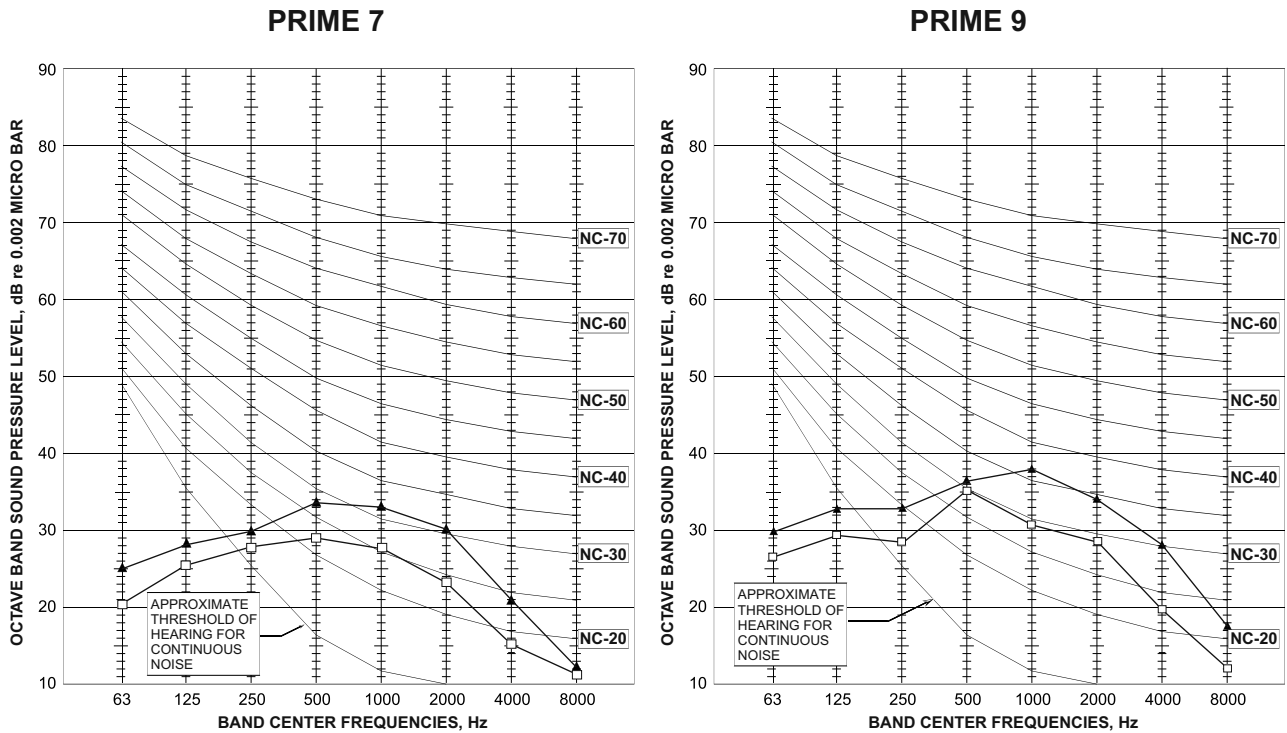

Figure 1

6.2 Sound Pressure Level Spectrum (Measured as Figure 1)



FAN SPEED	LINE
HI	—▲—
ME	—○—
LO	—□—

6.2 Sound Pressure Level

PRIME 12

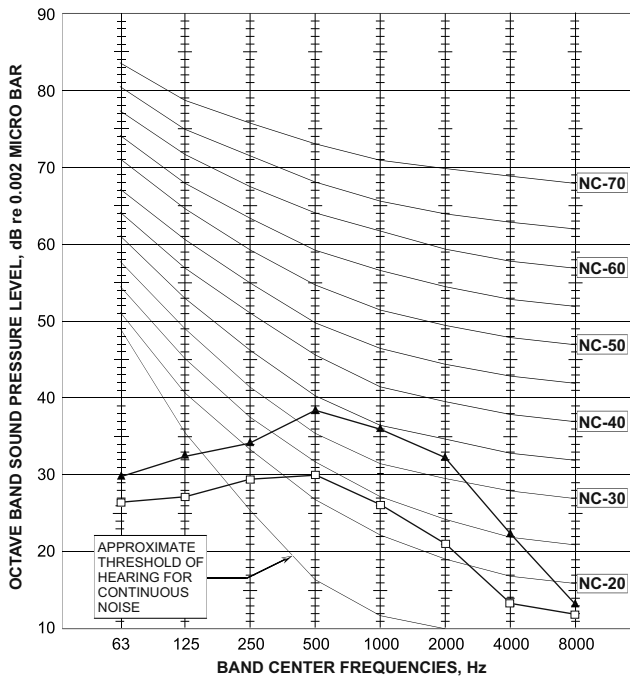

PRIME 18

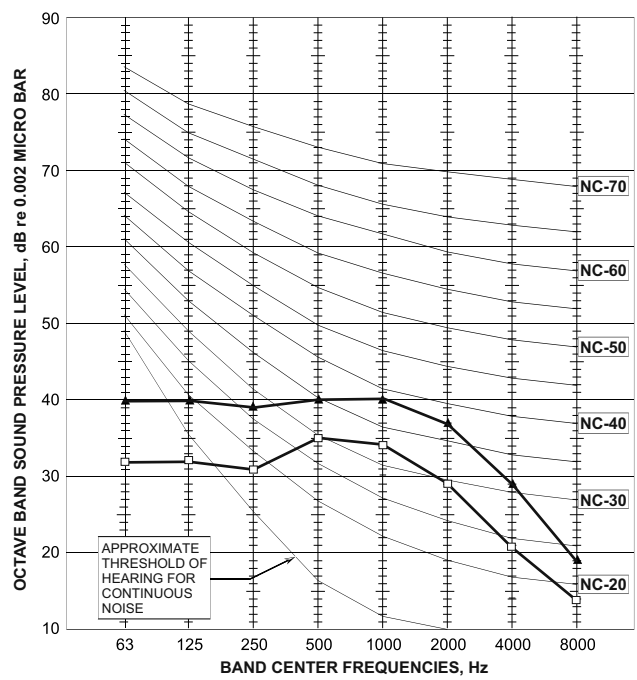

FAN SPEED	LINE
HI	—▲—
ME	—○—
LO	—□—

6.3 Outdoor units

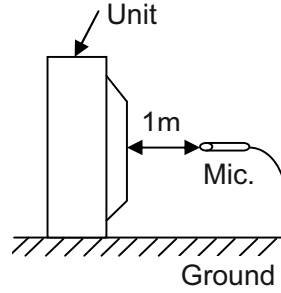
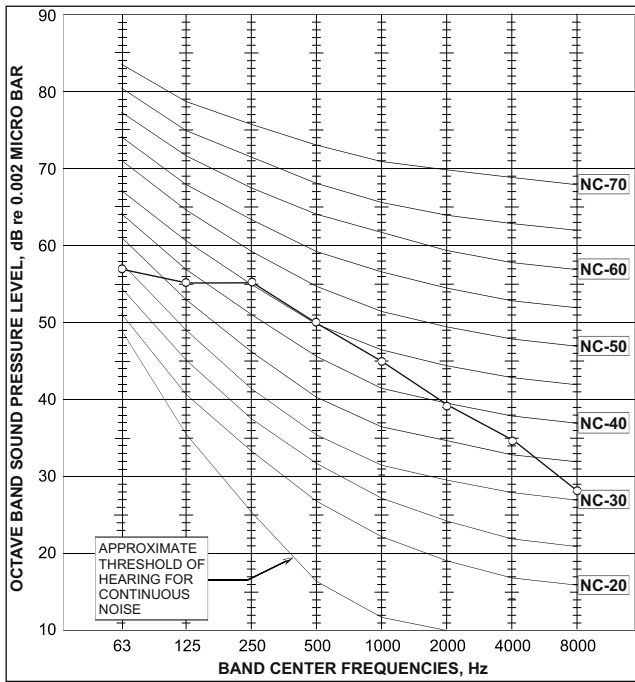

Figure 2

6.4 Sound Pressure Level Spectrum (Measured as Figure 2)

GC7 Cooling



GC7 Heating

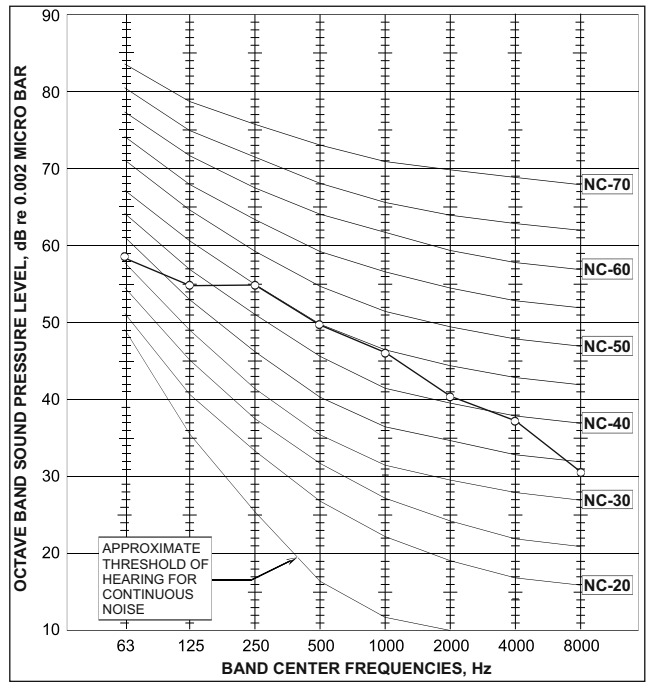

GCN9 (class A) Cooling

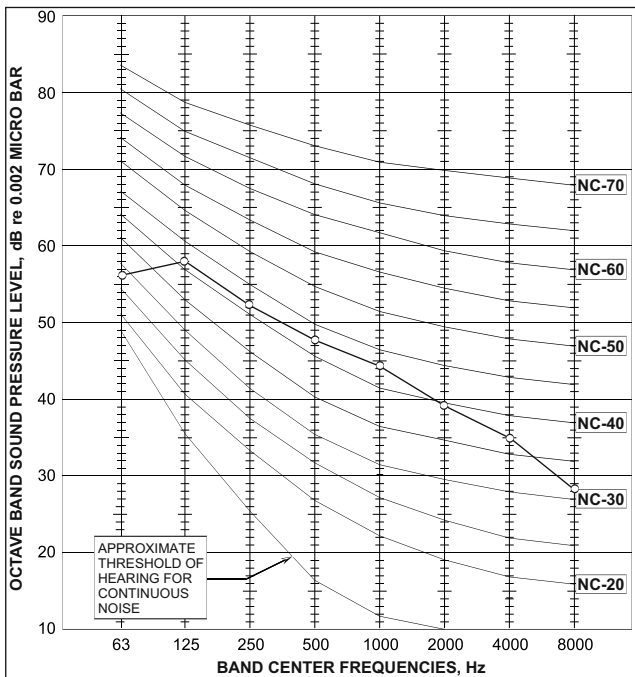

GCN9 (class A) Heating

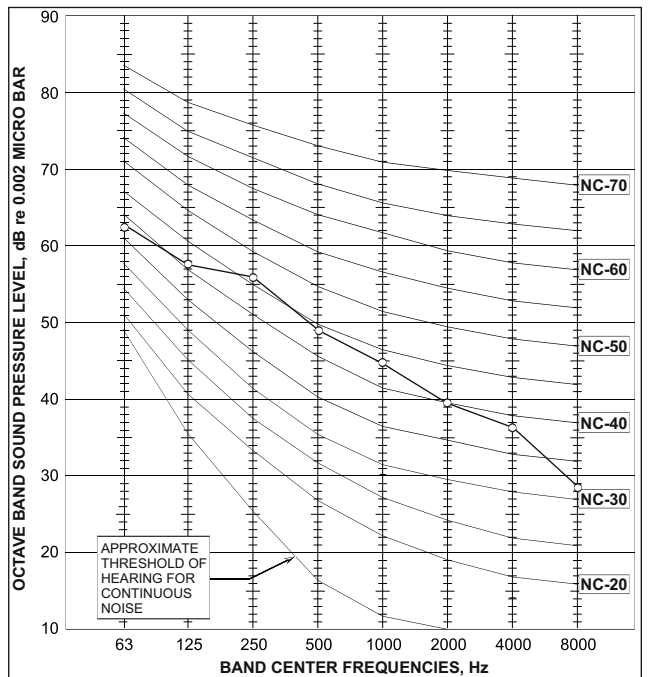

GCN12 (class A) Cooling

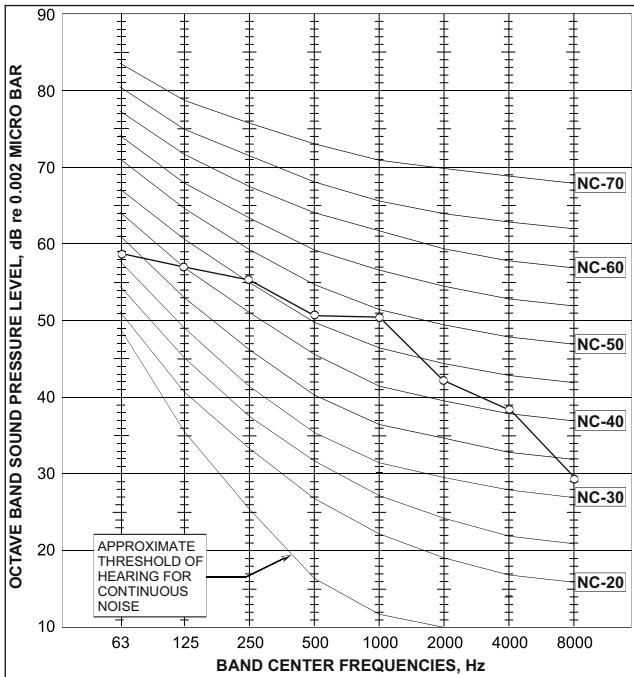

GCN12 (class A) Heating

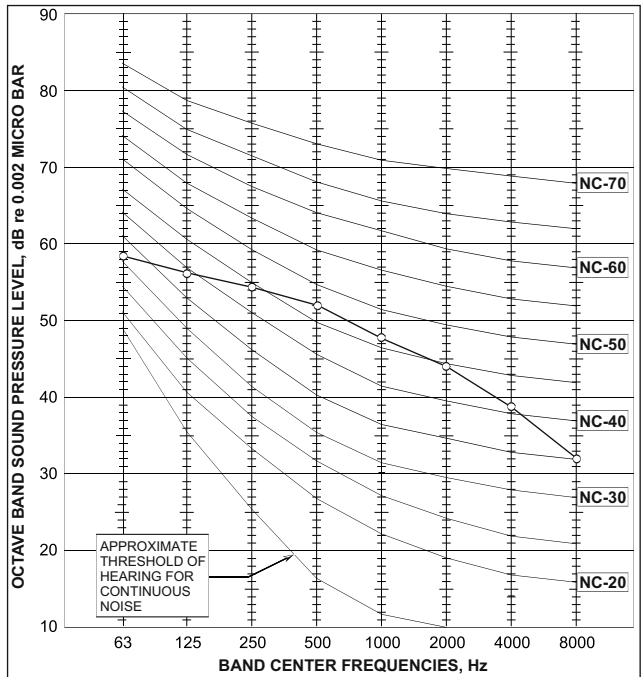

CSP9 (class C) Cooling

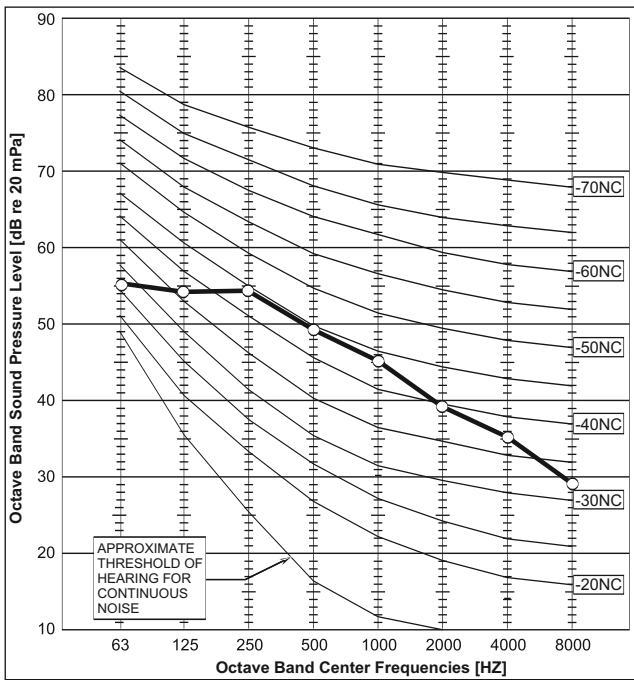

CSP9 (class C) Heating

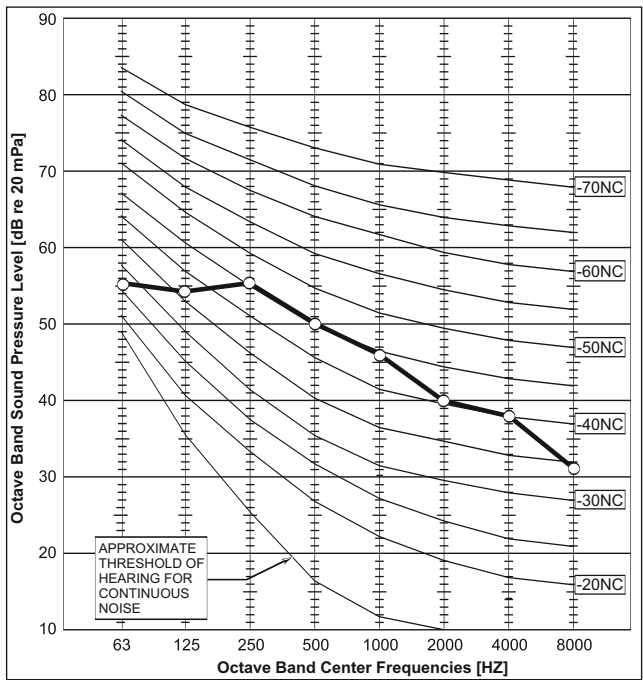

FAN SPEED	LINE
HI	—▲—
ME	—○—
LO	—□—

CON12 (class C) Cooling

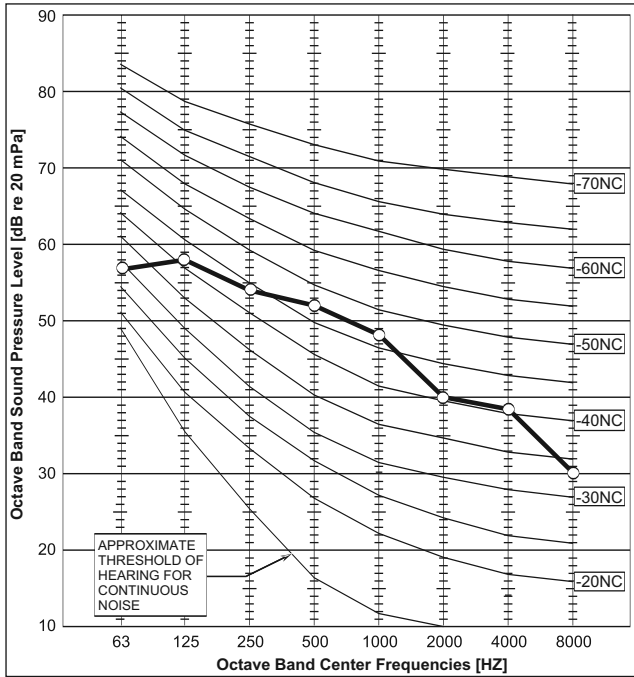

CON12 (class C) Heating

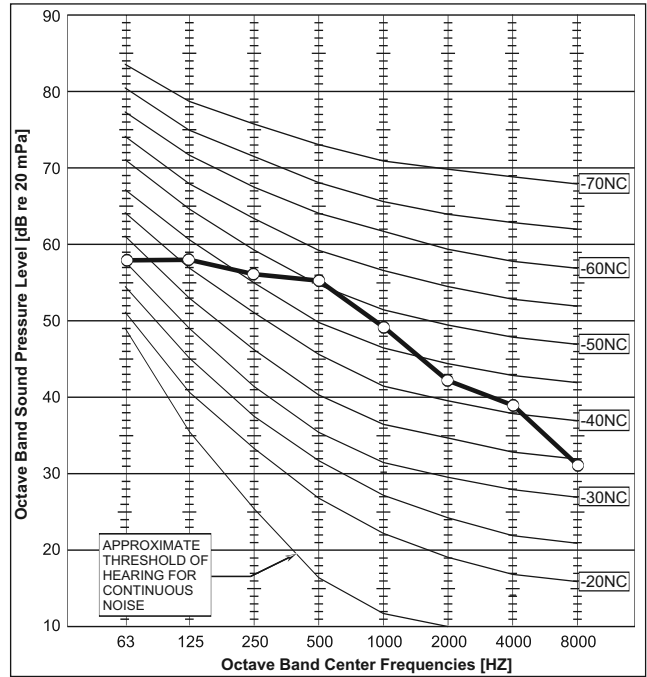

CON17 Cooling

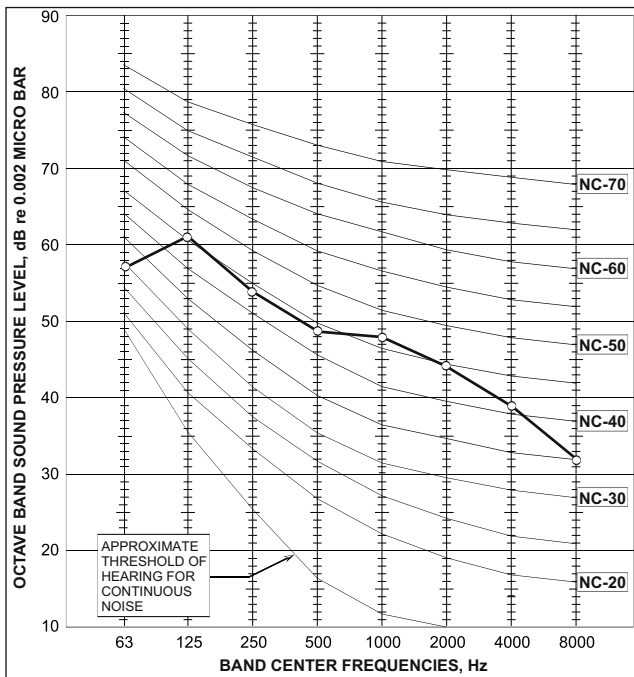

CON17 Heating

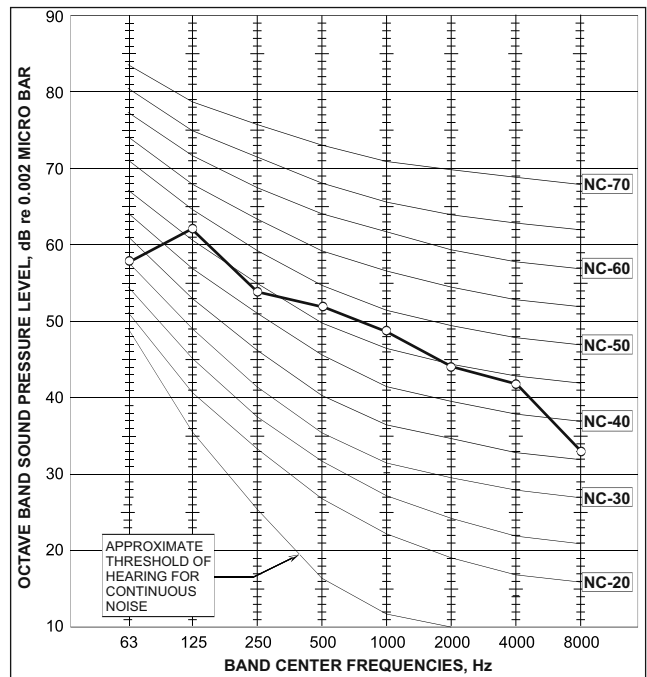

CSP12 RC R22 Cooling

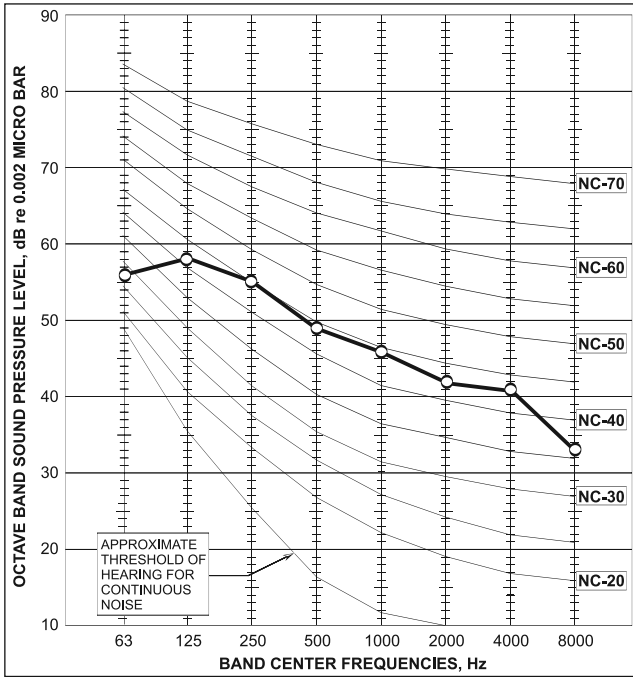

CSP12 RC R22 Heating

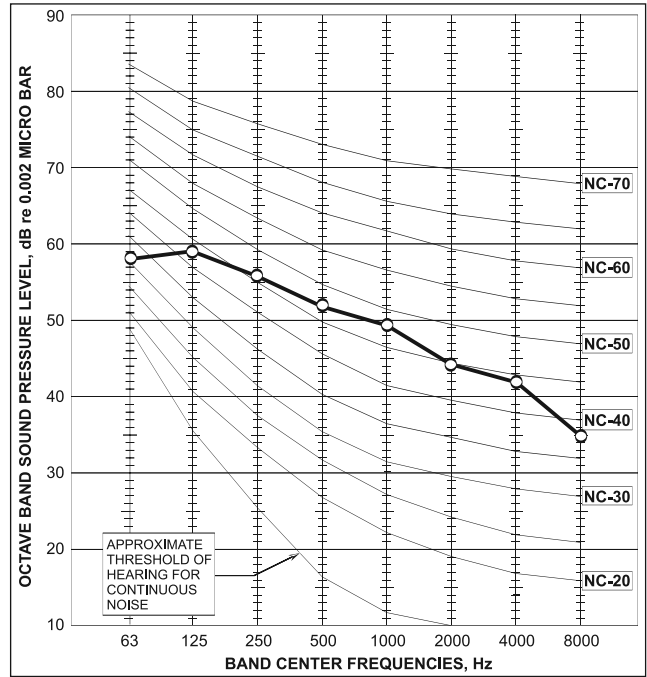

ONG3-17 RC R22 Cooling

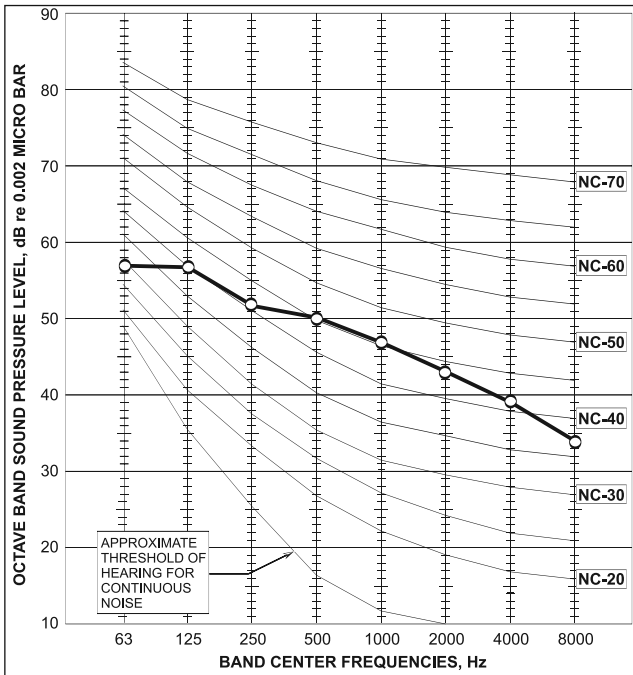

ONG3-17 RC R22 Heating

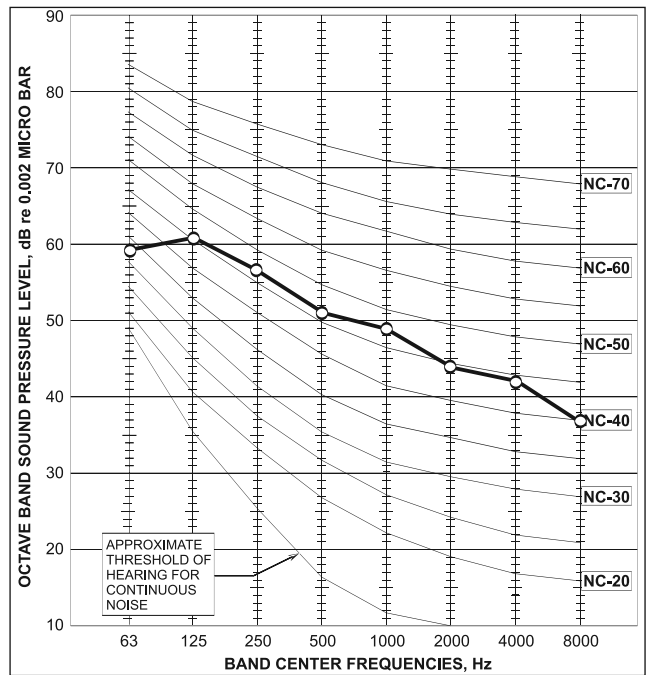

7. ELECTRICAL DATA

7.1 Single Phase Units

MODEL	Prime 7	Prime 9
Power Supply	To indoor	To indoor
	1PH-230V-50Hz	1PH-230V-50Hz
Max Current, A	4.1	6.5
Circuit Breaker,A	10	10
Power Supply Wiring No. X Cross Section mm ²	3x1.0 mm ²	3x1.0 mm ²
Interconnecting Cable RC Model No. X Cross Section mm ²	5x1.0 mm ² +2x0.5 mm ² (OCT sensor)	5x1.0 mm ² +2x0.5 mm ² (OCT sensor)
Interconnecting Cable ST Model No. X Cross Section mm ²	4x1.0 mm ²	4x1.0 mm ²

MODEL	Prime 12	Prime 18
Power Supply	To indoor	To indoor
	1PH-230V-50Hz	1PH-230V-50Hz
Max Current, A	7.7	10.4
Circuit Breaker,A	10	15
Power Supply Wiring No. X Cross Section mm ²	3x1.0 mm ²	3x1.5 mm ²
Interconnecting Cable RC Model No. X Cross Section mm ²	5x1.0 mm ² +2x0.5 mm ² (OCT sensor)	5x1.5 mm ² +2x0.5 mm ² (OCT sensor)
Interconnecting Cable ST Model No. X Cross Section mm ²	4x1.0 mm ²	4x1.5 mm ²

NOTE

Power wiring cord should comply with local laws and electrical regulations requirements.

8. WIRING DIAGRAMS

8.1 Indoor Unit : Prime 7, 9, 12, 18

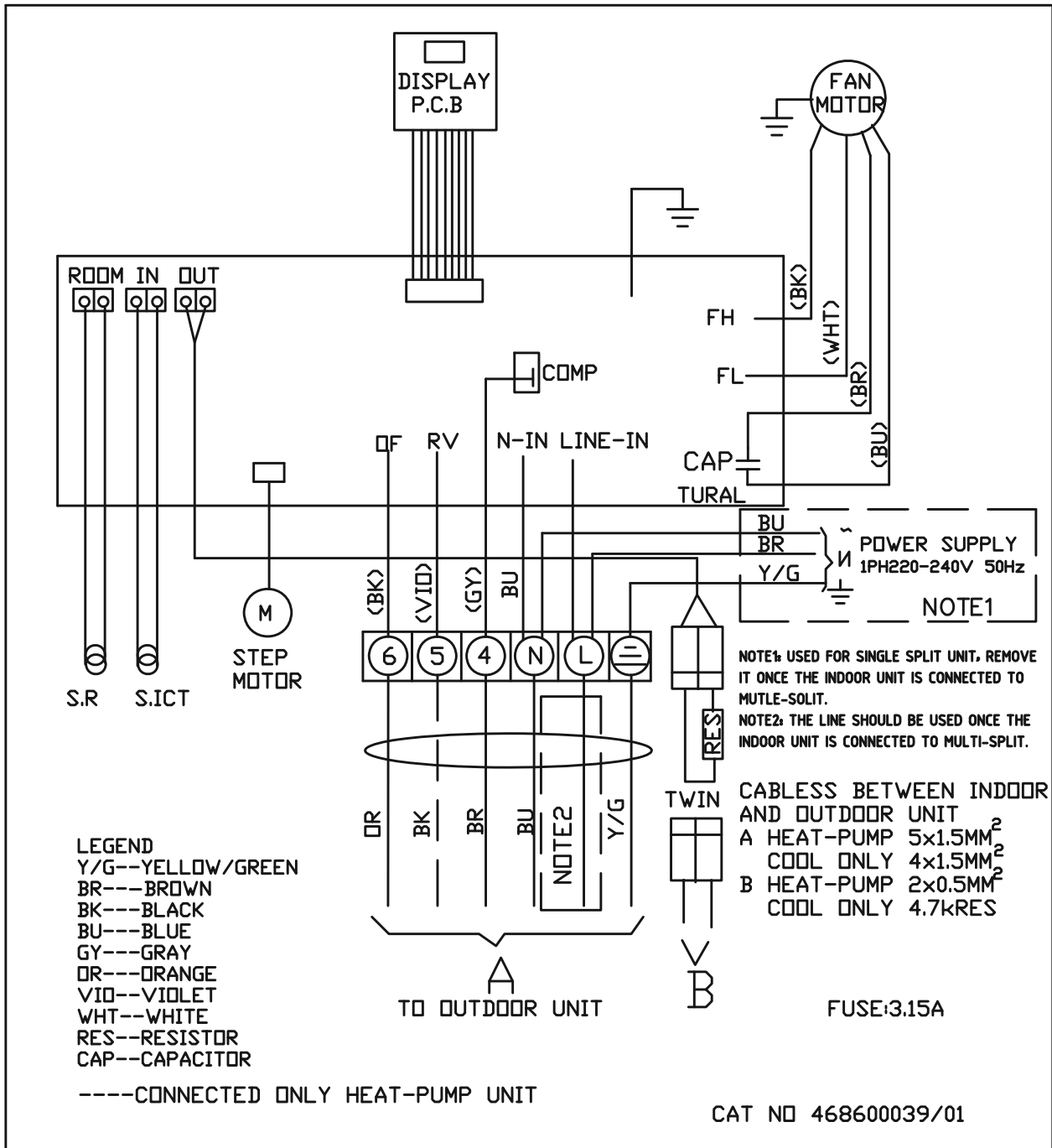

8.2 Outdoor Unit: CON 7 R22/R410A / CSP 9, 12 R22/R410A

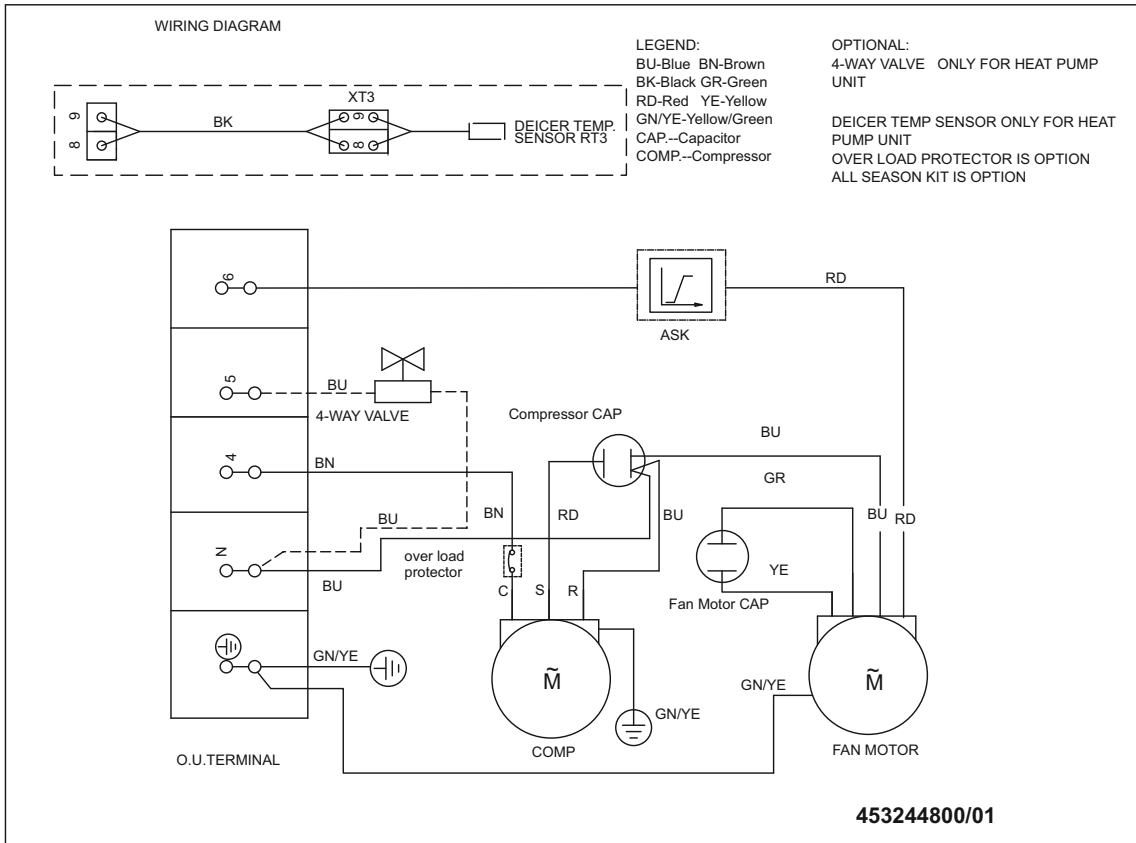

8.3 Outdoor Unit: GCN 9, 12 R410A

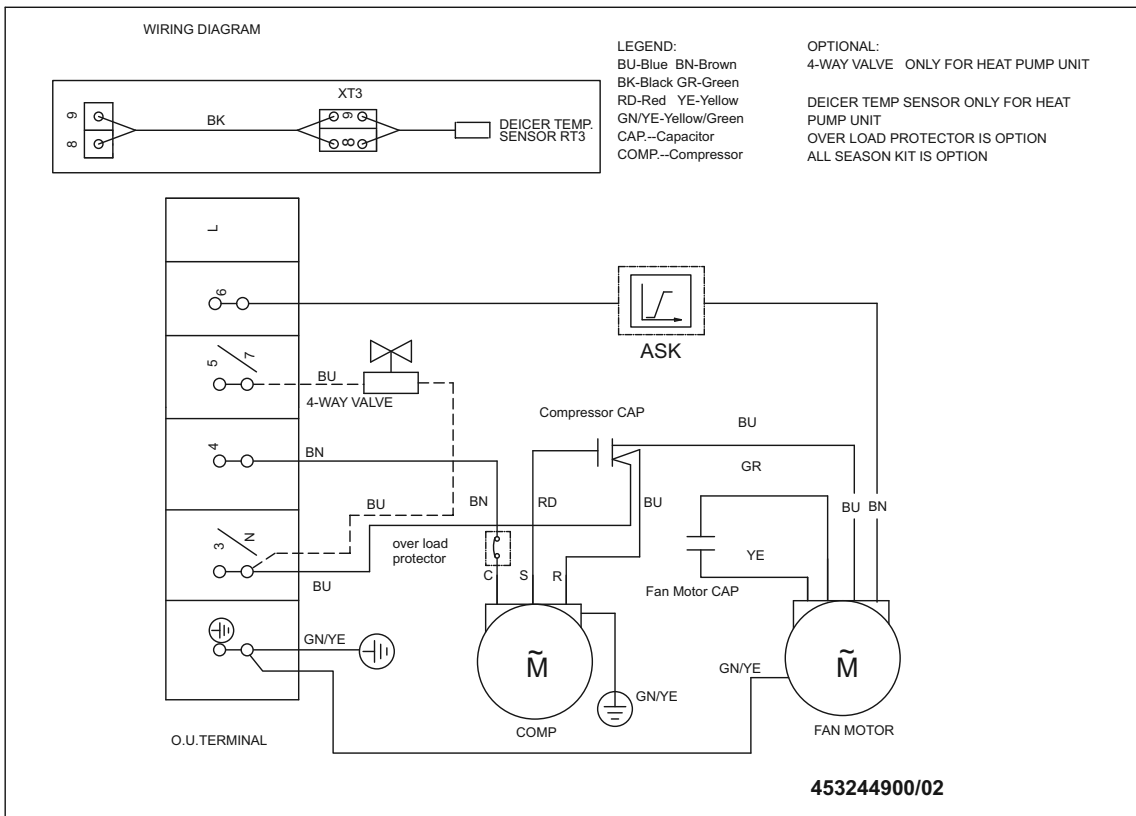

8.4 Outdoor Unit: ONG3-17 R22/R410A

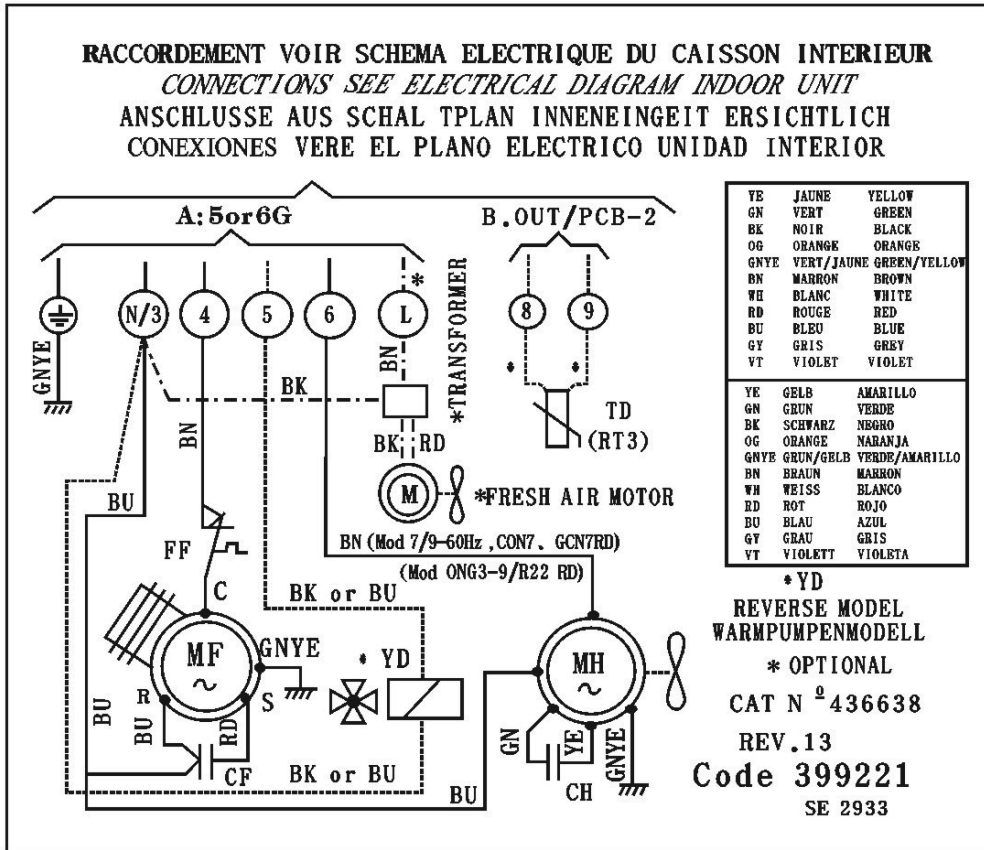

9. ELECTRICAL CONNECTIONS

9.1 ASP9, 12 / CSP9, 12

indoor unit

outdoor unit

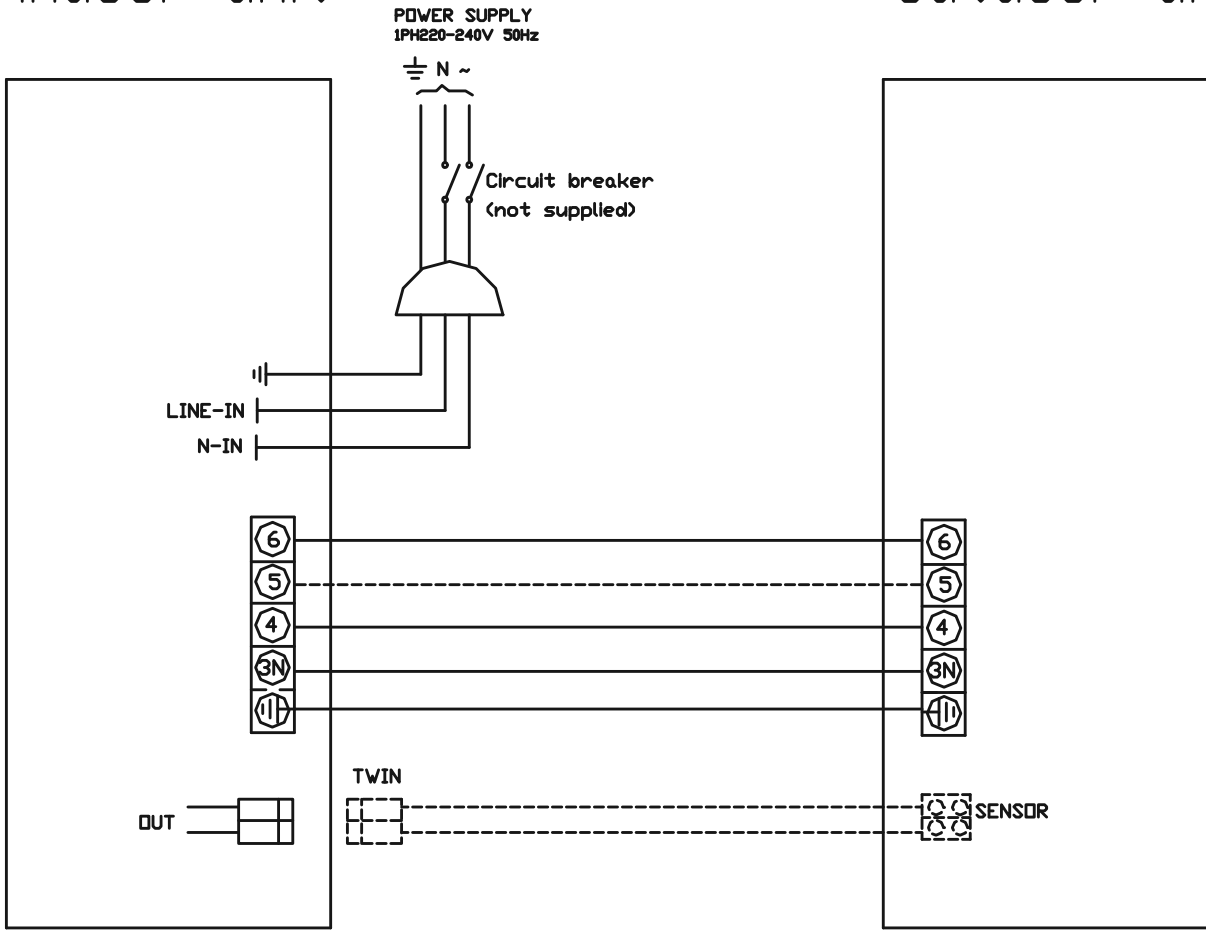

----CONNECTED ONLY HEAT-PUMB UNIT

10. REFRIGERATION DIAGRAMS

10.1 Heat Pump Models

10.1.1 Prime7, 9, 12, 18 RC R410A(class A) / Prime12, 18 R22

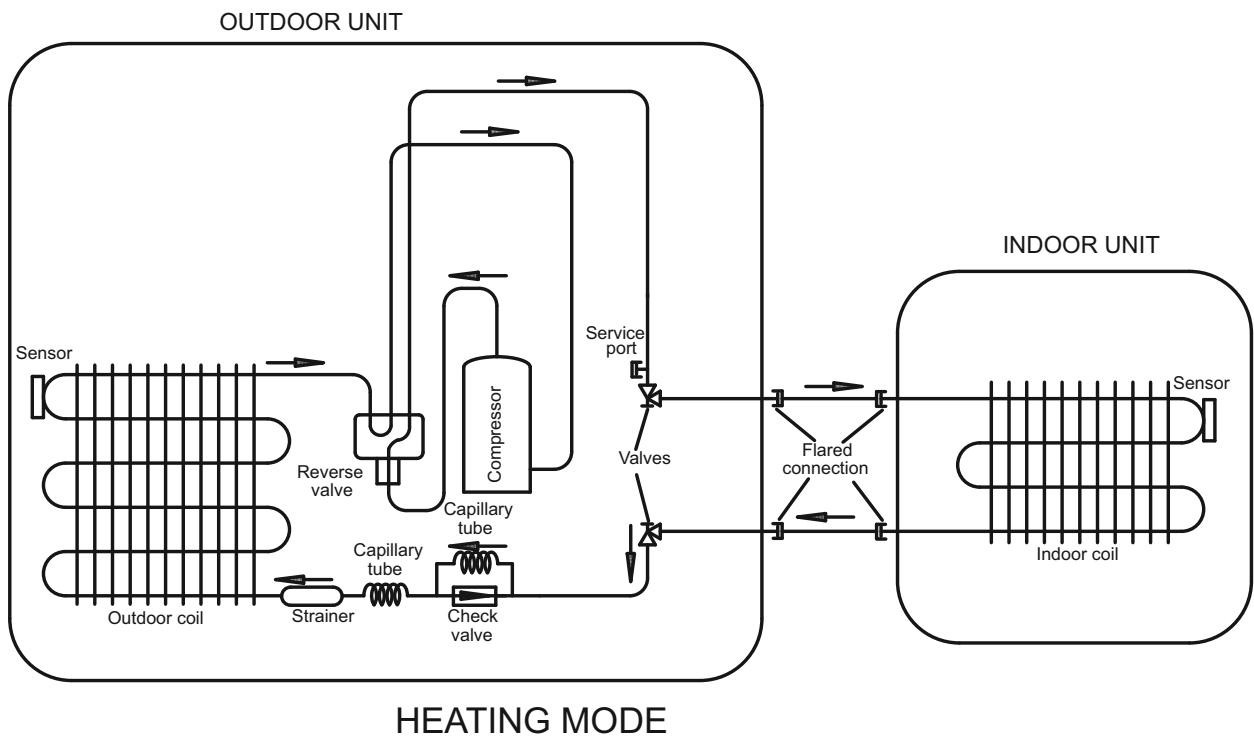
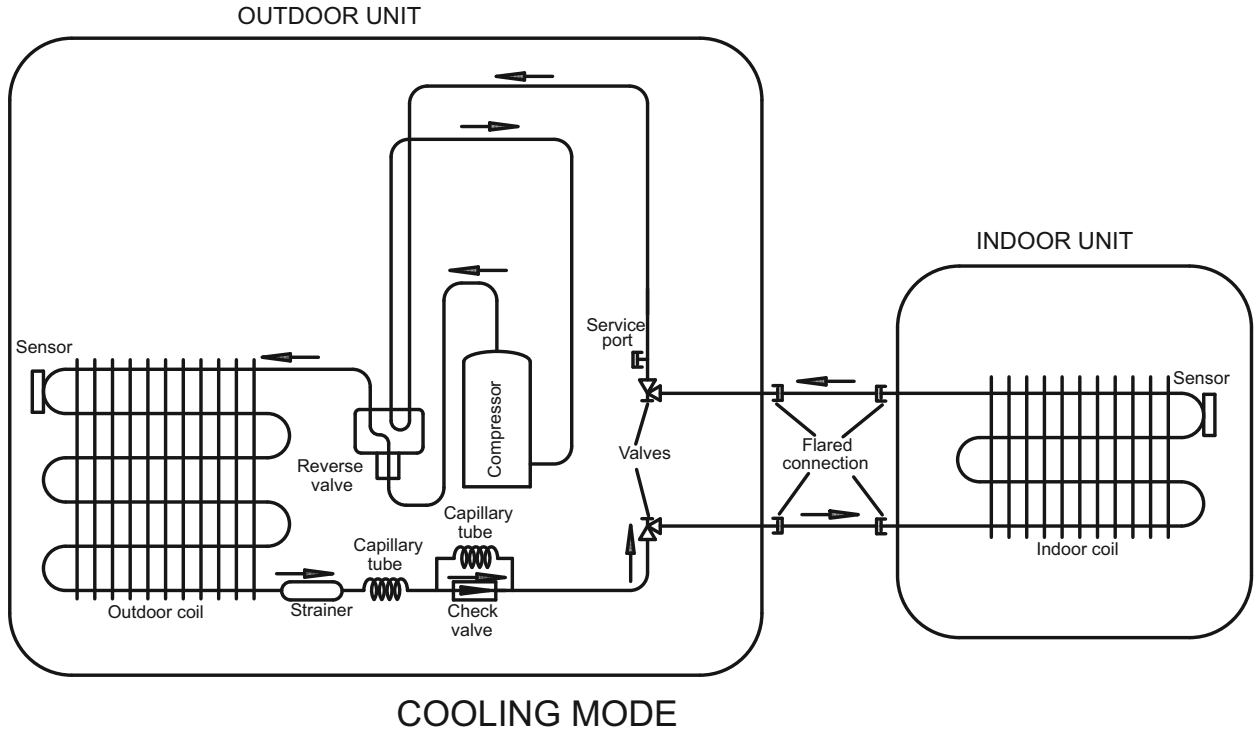

10.1.2 Prime7, 9 RC R22 / Prime9, 12 RC R410A(class C)

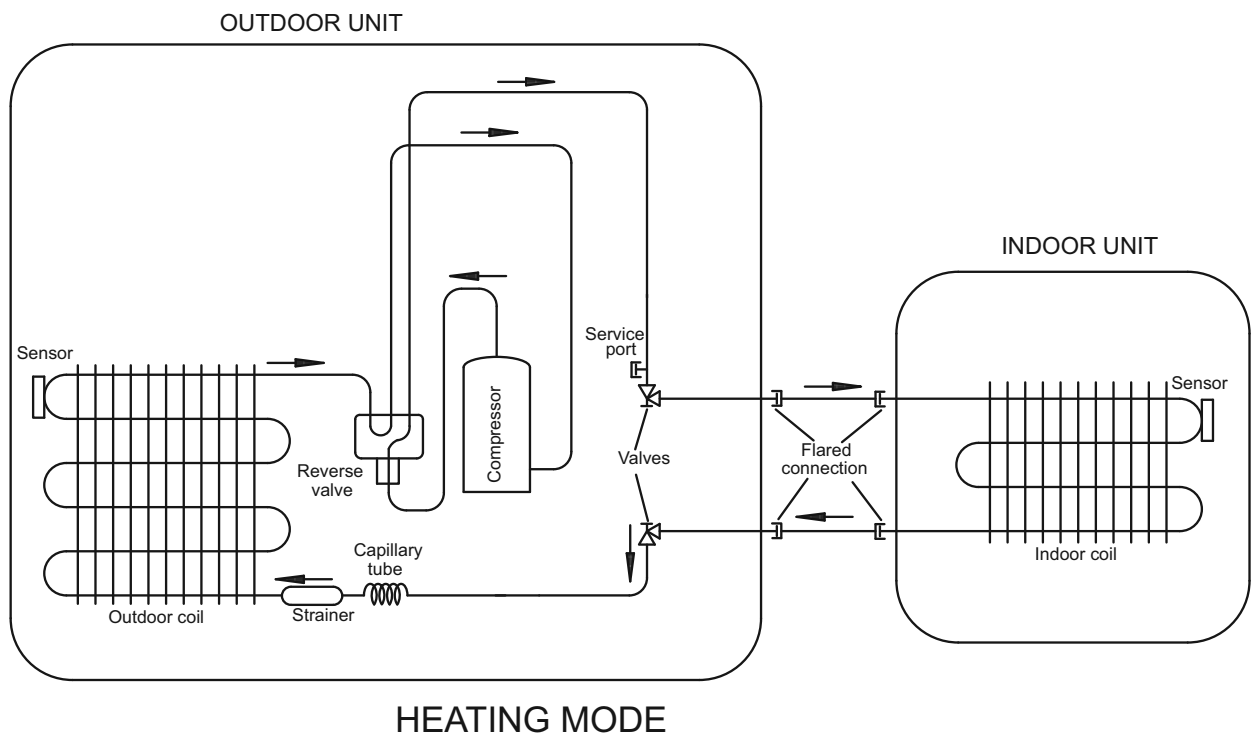
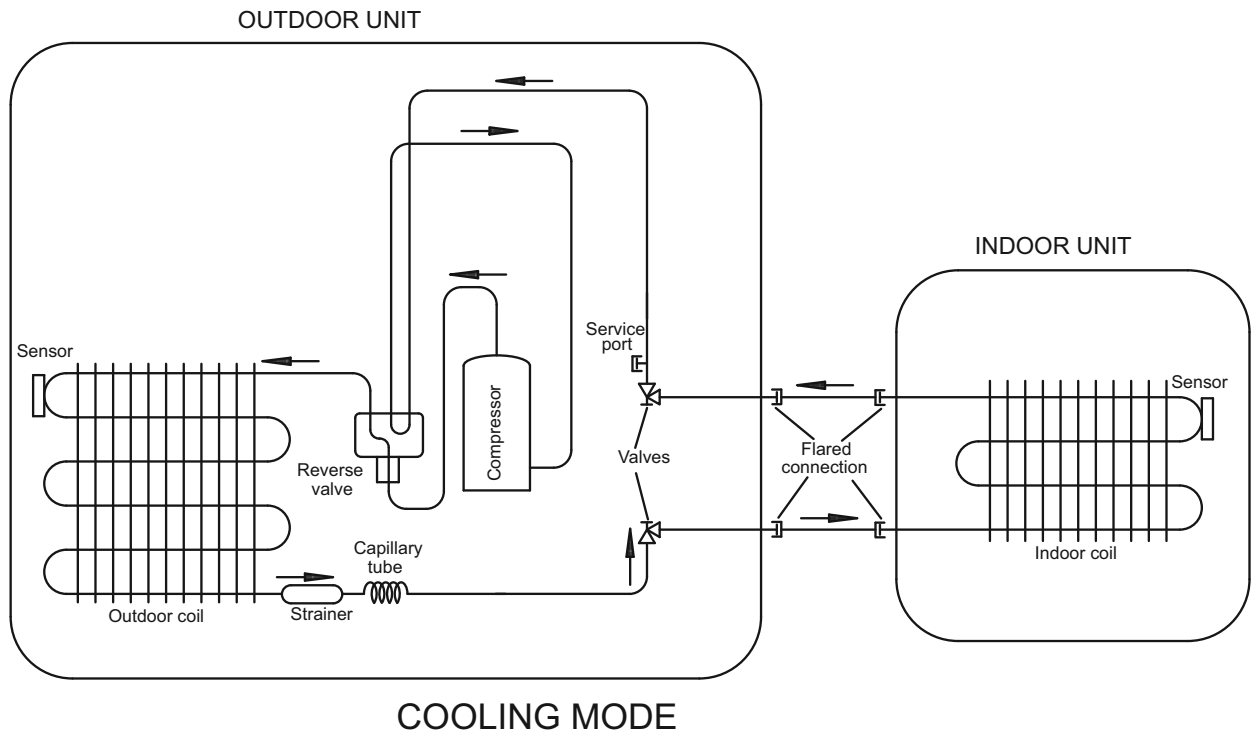

10.1.3 COOLING ONLY
All Model

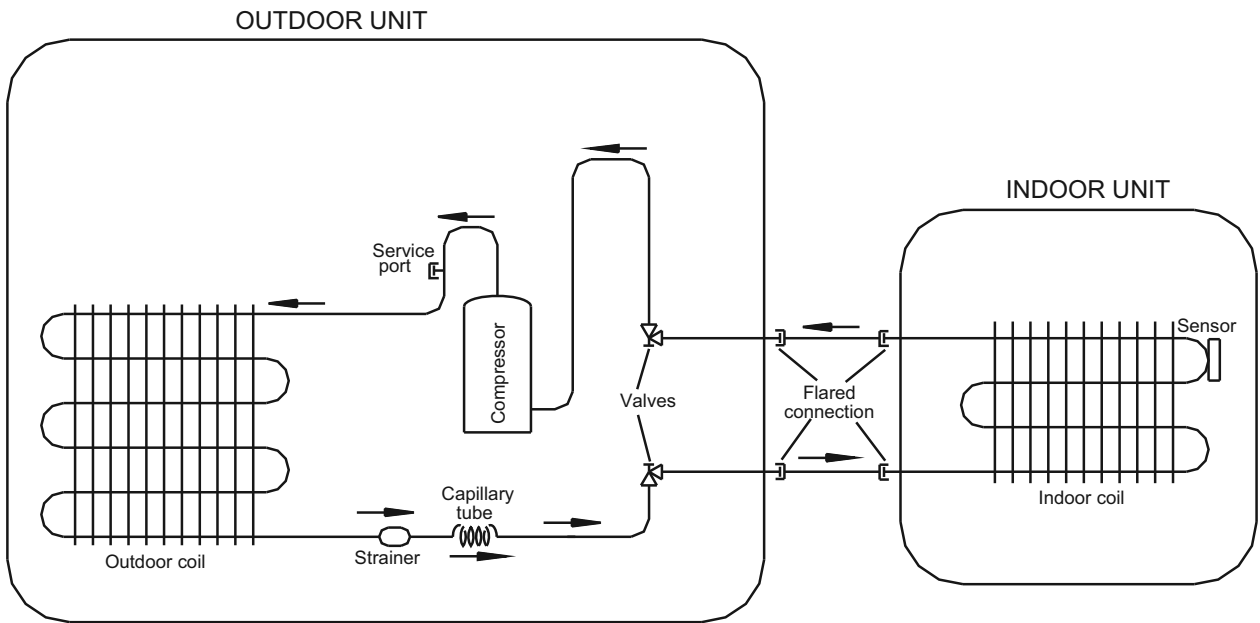

11. TUBING CONNECTIONS

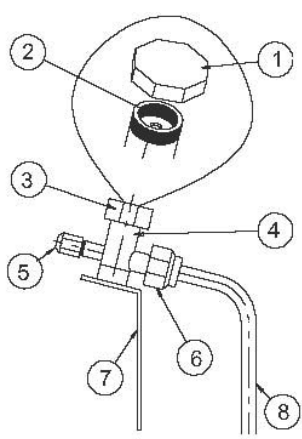
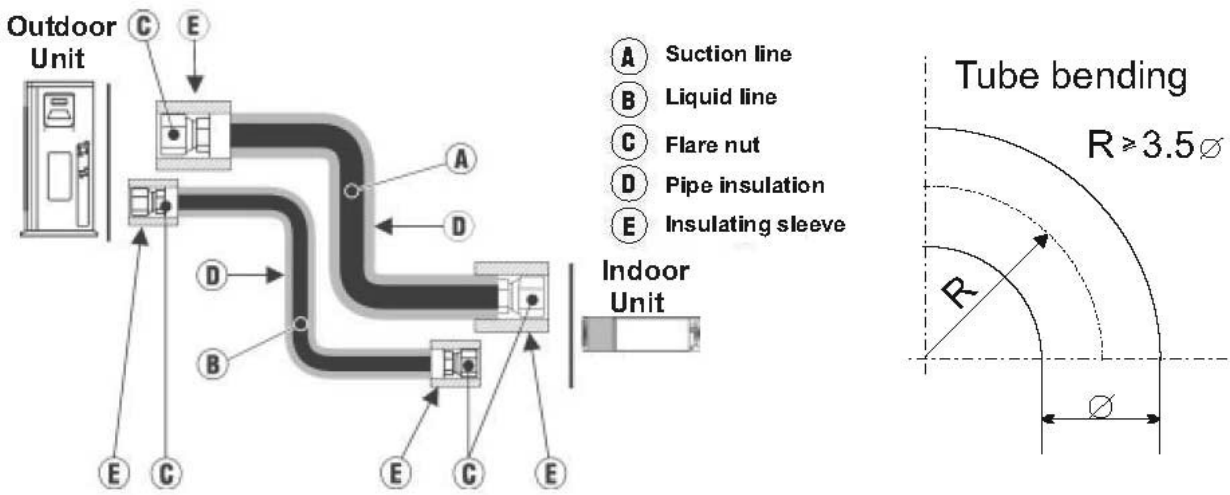

TUBE (Inch)	1/4"	3/8"	1/2"	5/8"	3/4"
TORQUE (Nm)					
Flare Nuts	11-13	40-45	60-65	70-75	80-85
Valve Cap	13-20	13-20	18-25	18-25	40-50
Service Port Cap	11-13	11-13	11-13	11-13	11-13

1. Valve Protection Cap-end
2. Refrigerant Valve Port (use Allen wrench to open/close)
3. Valve Protection Cap
4. Refrigerant Valve
5. Service Port Cap
6. Flare Nut
7. Unit Back Side
8. Copper Tube

When the outdoor unit is installed above the indoor unit an oil trap is required every 5m along the suction line at the lowest point of the riser. In case the indoor unit is installed above the outdoor, no trap is required.

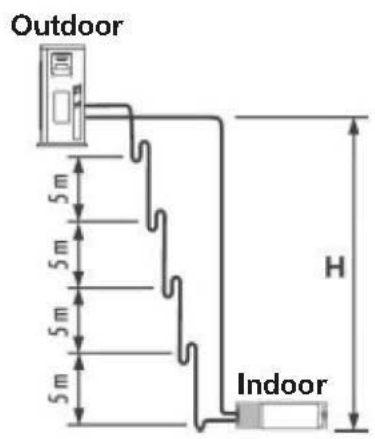

12. CONTROL SYSTEM PRIME 7, 9, 12, 17

12.1 Electronic Control

12.1.1 Introduction

The electronic control information is designed for service applications, and is common to the following groups of air-conditioners:

- **ST/ RC group** -Cooling only / cooling and heating by heat pump.
- **SH group** -Cooling and heating by heat pump and supplementary heater.
- **RH group** -Cooling, heating by heaters only.

12.1.2 Jumpers Settings

GROUP	J6 Setting	J2 Setting
ST / RC	Open	Open
SH	Closed	Open
RH	Closed	Closed

12.2 Legend

AC	- Alternate Current
A/C	- Air-Conditioner
ANY	- ON or OFF status
CLOCK	- ON/OFF Operation Input, (dry contact)
COMP	- Compressor
CPU	- Central Processing Unit
ELUM	- Extended Louver Upward Movement (Software Jumper)
E ² PROM, EEP	- Erase Enable Programmable Read Only Memory
HE	- Heating Element
HPC	- High Pressure Control
H/W	- Hardware
ICP	- Indoor Condensation Pump
ICT	- Indoor Coil Temperature (RT2) sensor
IF, IFAN	- Indoor Fan
IR	- Infra Red
LEVEL1	- Normal Water Level
LEVEL2/3	- Medium/High Water Level
LEVEL4	- Overflow Level
Max	- Maximum
Min	- Minimum
min	- Minute (time)
NA	- Not Applicable
OCP	- Outdoor Condensation Pump
OCT	- Outdoor Coil Temperature (RT3) sensor
OF, OFAN	- Outdoor Fan
OPER	- Operate
Para.	- Paragraph
RAT	- Return Air Temperature (RT1) sensor
RC	- Reverse Cycle (Heat Pump)
R/C	- Remote Control
RCT	- Remote Control Temperature
RH	- Resistance Heater
RT	- Room Temperature (i.e. RCT in IFEEL mode, RAT otherwise)
RV	- Reversing Valve
SB, STBY	- Stand-By
sec	- Second (time)
Sect	- Section
SH	- Supplementary Heater
SPT	- Set Point Temperature
ST	- Standard (a Model with Cooling Only)
S/W	- Software
TEMP	- Temperature
W/O	- Without
WVL	- Water Valve
ΔT	- The difference between SPT and RT. in Heat Mode: $\Delta T = SPT - RT$ in Cool/Dry/Fan Mode: $\Delta T = RT - SPT$

12.3 General functions

12.3.1 COMP operation

For each Mode including POWER OFF & SB, a Min time delay of 3 min before COMP restarting, excluding DEICING Mode

The Min operation time of COMP under different operating conditions is

Operation Mode	Min operation time of COMP
Heat, Cool or Auto Modes	3 min.
Fan, Dry, Overflow, Protection modes, or mode change	ignored

12.3.2 IFAN operation

- Min time interval between IFAN speed change in AUTOFAN Mode, is 30 sec.
- Min time interval between IFAN speed change in H/M/L Mode is 1 sec.
- IFAN speed in Heat/Cool Autofan Mode is determined according to the following table:

ΔT	IFAN Speed
$\Delta T \geq 2$	HIGH
$2 \geq \Delta T \geq 1$	MED
$1 \geq \Delta T$	LOW

where in Heat Mode: $\Delta T = SPT - RT$
in Cool Mode: $\Delta T = RT - SPT$

Note:

- In Heat Mode, the rules in section 4.0.3 have the higher priority.
- The table above can be represent by a hysteresis curve which will minimize the switching of the IFAN relay and will minimize the change in IFAN speed:

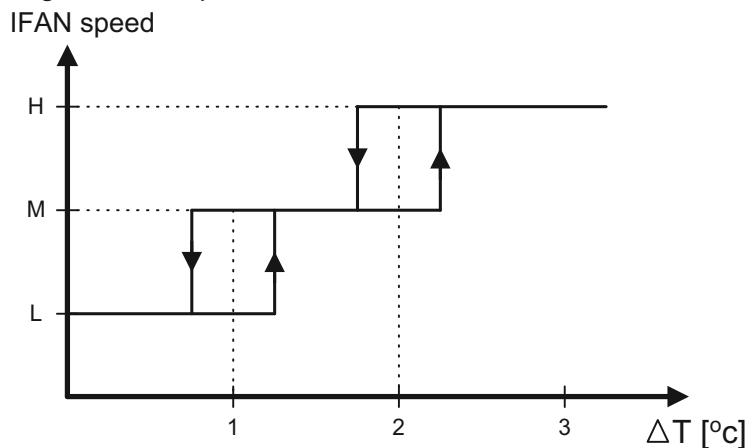

12.3.3 OFAN operation

- Min time interval between OFAN ON/OFF state change is 30 sec.
- In general, OFAN starts together with COMP.

12.3.4 HE operation

- Minimum Heaters ON or OFF time is 30 sec.
- Heaters can be activated only if IFAN is on.

12.3.5 Protections

- High pressure protection is applicable to all operating modes.
- Deicing control is valid in Heat and Auto Heat Mode only.
- Defrosting control is valid in Dry, Cool, Heat and Auto Modes.
- No reset after protection modes.

12.3.6 Thermistors operation

- Return air Temp. is detected by RAT (RT1) in normal Mode, or by RCT (R/C sensor) in I-FEEL Mode.
- Indoor Coil Temp. is detected by ICT (RT2).

12.3.6.1 **Definition of thermistor faults:**

- a. Thermistor is disconnected -
The thermistor reading is below -30°C .
- b. Thermistor is shorted -
The thermistor reading is over 75°C .
- c. Thermistor Temp reading doesn't change (irrelevant for RT1) -
 - (i) This test is performed only once after a unit is switched from OFF/STBY to operation. At the first occurrence of 10 min continuous COMP operation, the current ICT & OCT are compared with those when the COMP was switched from OFF to ON 10 min before. If the ΔT is less than 3°C , the thermistor is regarded as defective.
 - (ii) The ICT and OCT no-change error can be disabled together by connecting a 4.7 kohm resistor (5%) to the OCT connector. These resistors are equivalent to a thermistor at $43\pm 1^{\circ}\text{C}$ and $48\pm 1^{\circ}\text{C}$ respectively.
 - (iii) Connecting a 4.7 k resistor to the ICT connector will disable the ICT no-change error only.

12.3.6.2 Handling the thermistor faults in a COMP unit

- i. ICT/OCT thermistor is disconnected or shorted -
The invalid thermistor temperature is replaced by 43°C, so that the unit can continue the normal operation. All protections related to that faulty thermistor will be disabled. For example, in case of any ICT fault, the ICT high pressure protection in Heat Mode and ICT defrost protection in Cool Mode will not operate anymore. The same is also applied to the OCT fault.
- ii. RAT thermistor is disconnected or shorted –
The RAT will be derived from the ICT by using the equations :
- Heat Mode: $RAT = ICT / 2.3$
Cool Mode $RAT = ICT * 4$

Notes:

- In case of any thermistor failure, the STBY LED will be blinking until the fault condition is corrected.
- User can use the system diagnostics function to find out the nature of the thermistor faults.

- i. RAT thermistor is disconnected or shorted –
System will operate continuously in the last IFAN & WVW status when turned ON.

Notes:

- As in the COMP unit, the STBY LED will be blinking to indicate a thermistor fault. And, the user can use the system diagnostics function to find out the nature of the fault.

12.4 Cooling Mode - General

- 1) Room Temperature, RT, is detected by
 - RAT in normal operation, or
 - RCT (R/C sensor) in I-FEEL mode.
- 2) The resolution of RT is 1°C.
 - RT is activating COMP/WVL if $(RT > SPT)$, and
 - RT is stopping COMP/WVL if $(RT \leq SPT)$.
- 3) Indoor Coil Temp is detected by ICT (RT2).
- 4) Outdoor Coil Temp is detected by OCT (RT3).
- 5) OFAN OPERATIONS
 - OFAN starts together with COMP in general.

12.4.1 Cooling

Mode: Cool, Auto (at Cooling)
 Temp: Selected desired temperature.
 Fan: HIGH, MED, LOW
 Timer: Any
 I Feel: On or Off

Control function

Maintains room temp at desired level by comparing RT and SPT.

(RT - SPT) [°C]

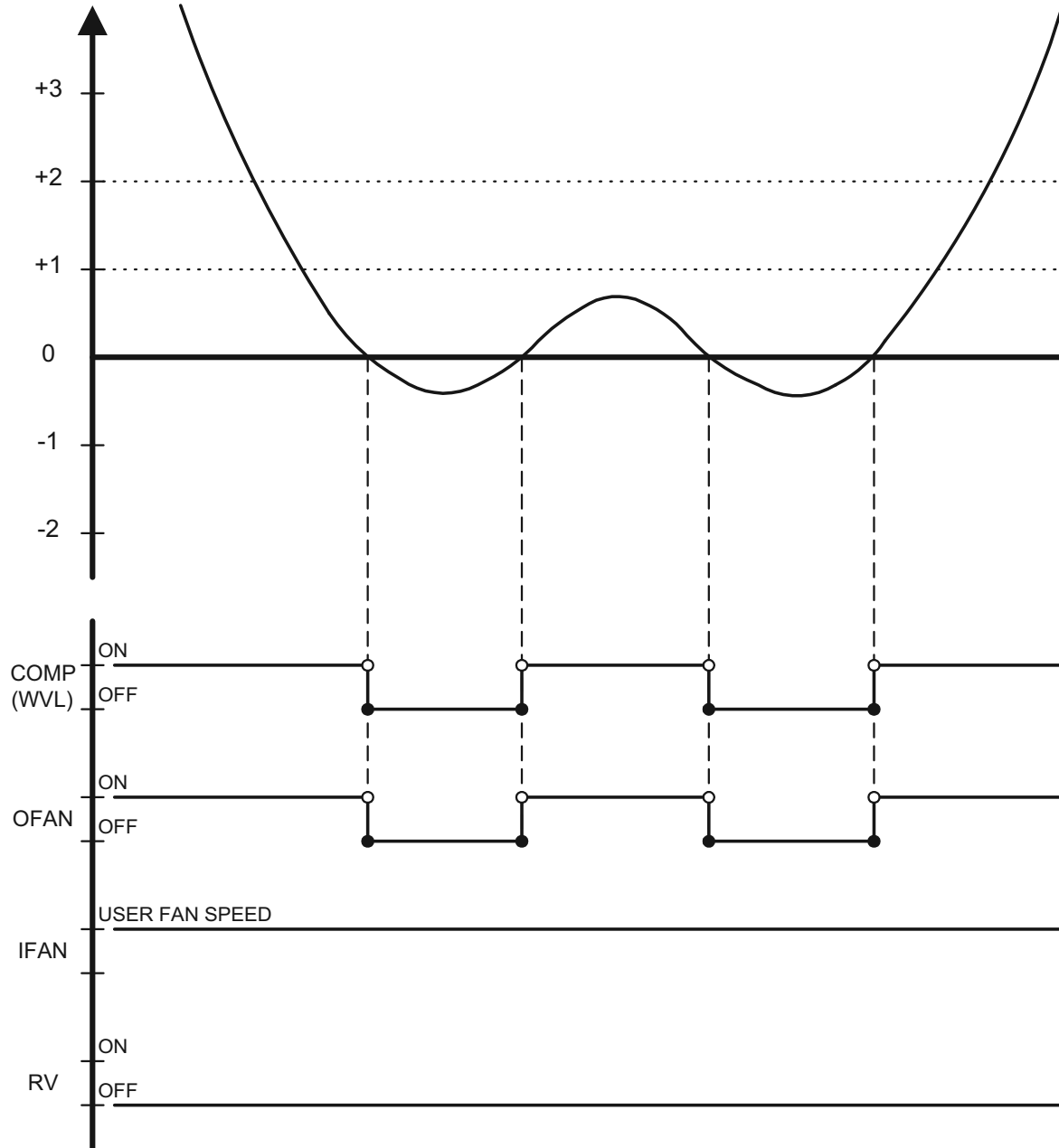

Note:

- 1) IFAN is always running at High, Medium or Low speed selected by user.
- 2) In IFEEL mode, the Room Temperature (RT) is the RCT from a R/C. Otherwise, the RT is the RAT from the Room Thermistor.

12.4.2 Cooling with Autofan

- Mode: Cool, Auto (at cooling)
- Temp: Selected desired temperature
- Fan: Auto
- Timer: Any
- I Feel: On or Off

Control function

Maintains room temp at desired level and controls the IFAN speed for optimal comfort.

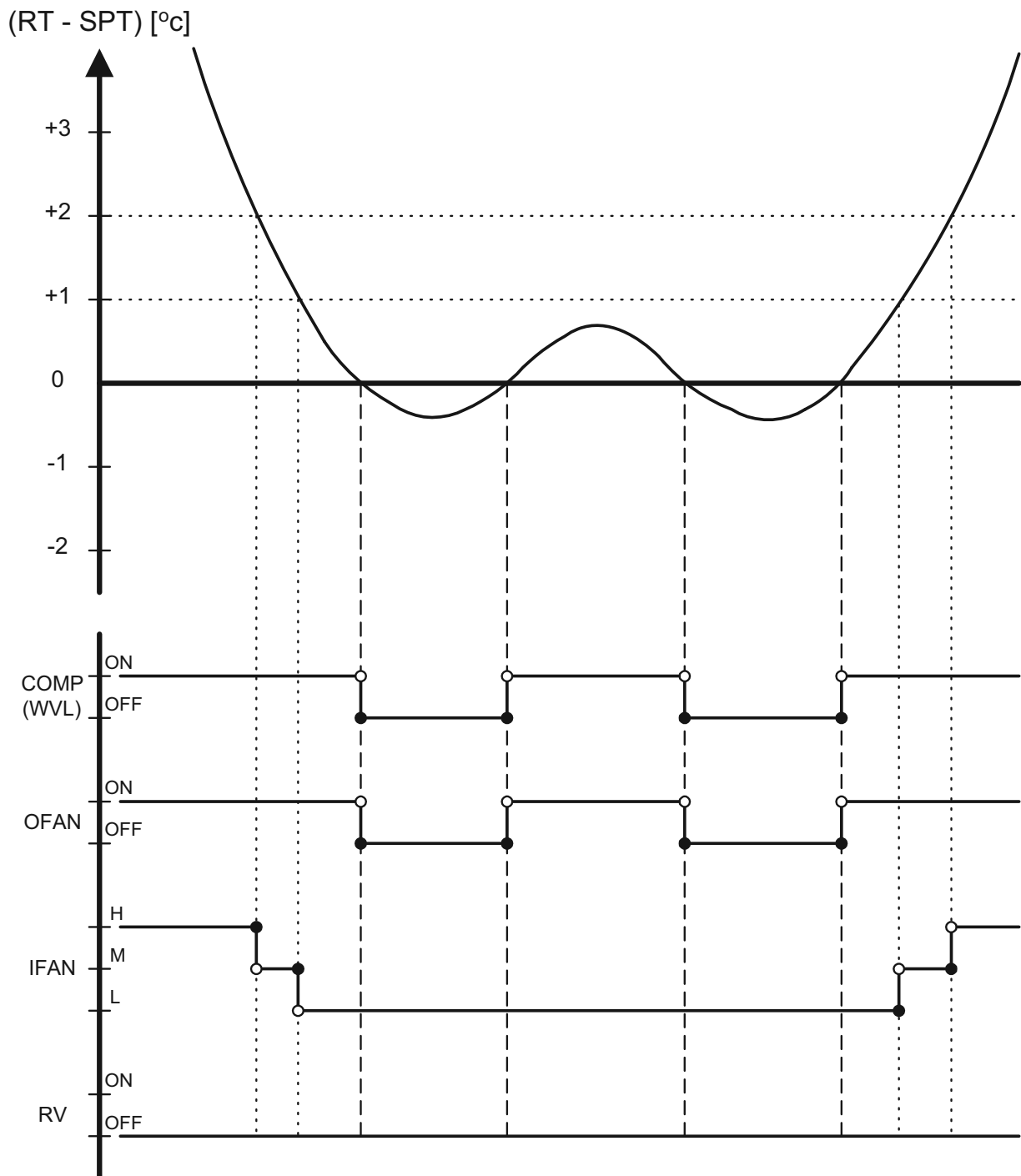

12.5 Heating Mode

12.5.1 Heating Mode - General

- In heating Mode, temp. compensation schedule will be activated for wall mounted units.

SPT [°C]	Add to SPT	
	I-FEEL ON	I-FEEL OFF
$18 \leq SPT \leq 27$	0 °C	+2 °C
$27 < SPT \leq 30$	0 °C	+3 °C

Notes :

- No compensation will be activated in Forced operation modes

12.5.2 IF operating rules

- As a general rule for **RC and SH groups**, when **COMP is ON**, excluding protection modes, IFAN will be switched ON if
- $ICT > 35^{\circ}\text{C}$ or
at the IFTC 30 sec after the COMP is switched ON. In this case, the IFAN will be started at low speed.

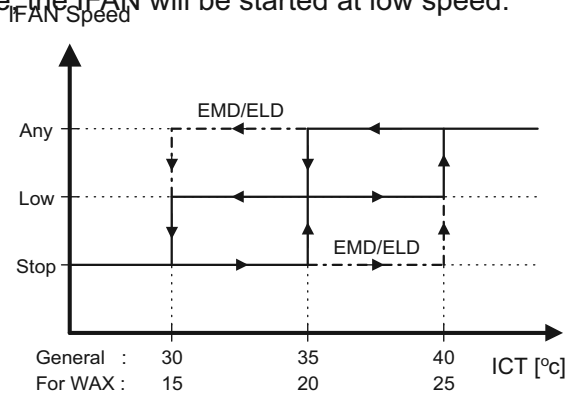

Notes :

- 1) In **SH or RC group**, if HE is set to OFF due to low ICT, IFAN will be switched to LOW and will be turned OFF after 30 sec.
 - 2) An exception to this rule (4.0.3.a) is the Back-up mode for SH.
- In **RC and SH groups**, whenever **COMP & HE are both OFF**, excluding protection modes, IFAN operation will be according to the following:

In **other models** IFAN will operate in low speed for 30 sec and then stop. If COMP is OFF for more than 3 minutes and IFEEL Mode is inactive, IFAN will operate in low speed according to the following graph:

IFAN (Low Speed)

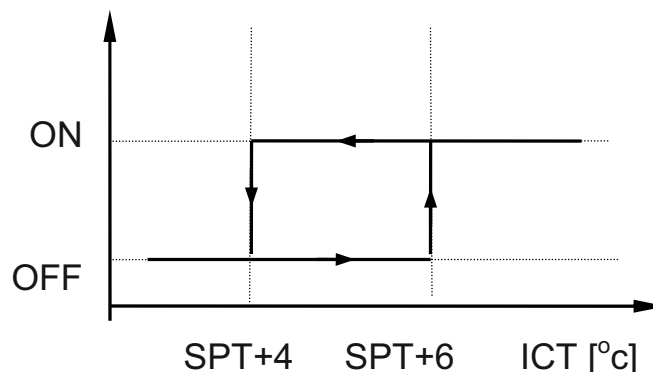

12.5.3 HE operation

- For **all Groups**, HE can be ON only when IFAN is ON.
- For **all Groups**, HE switches to OFF when $ICT > 50\text{ }^{\circ}\text{C}$, and is activated again when $ICT \leq 45\text{ }^{\circ}\text{C}$.
- In **SH or RC group**, HE operation is limited by the following graph:

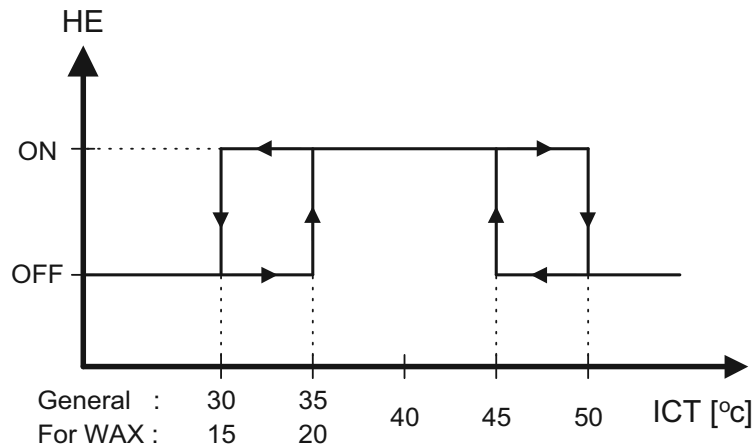

- Back-up mode for **SH group**

After COMP has been working for 5 minutes, HE & IFAN are activated even if the ICT is still below 35°C. This situation is called Back-up Mode. Both HE & IFAN will work in Back-up Mode until the ICT reaches 35°C. Then, the operation goes on in the usual mode .

12.5.4 Heating, RC or SH Group

Mode: Heat, Auto (at heating)
 Temp: Selected desired temperature
 Fan: HIGH, MED, LOW
 Timer: Any
 I Feel: On or Off

Control function

Maintains room temp. at desired level by comparing RAT or RCT to SPT.

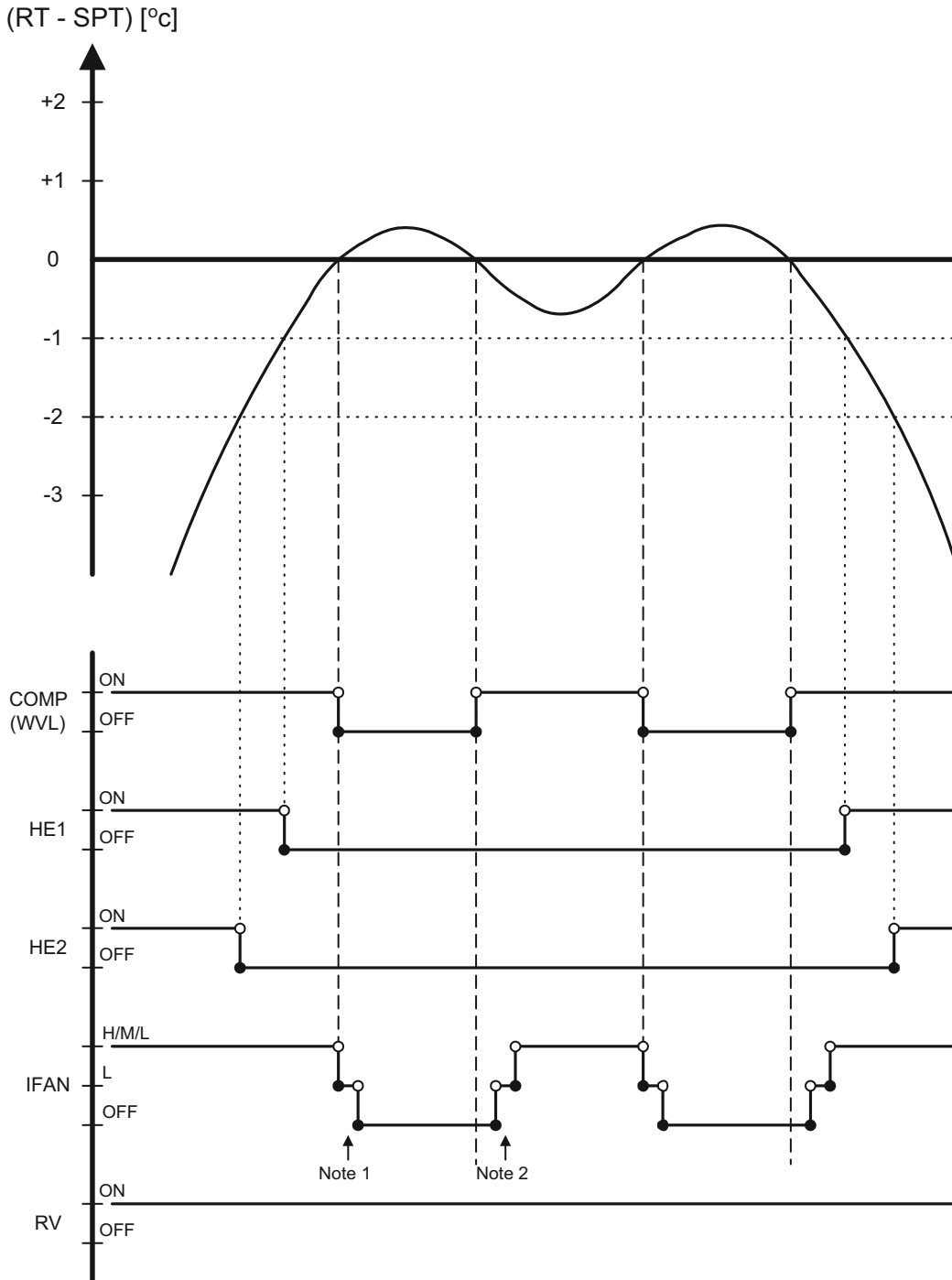

12.5.5 Heating, RC or SH Group with Autofan

Mode: Heat, Auto (at heating)
 Temp: Selected desired temperature
 Fan: Auto
 Timer: Any
 I Feel: On or Off

Control function

Maintains room temp at desired level by controlling COMP, IFAN and OFAN.

(RT - SPT) [°c]

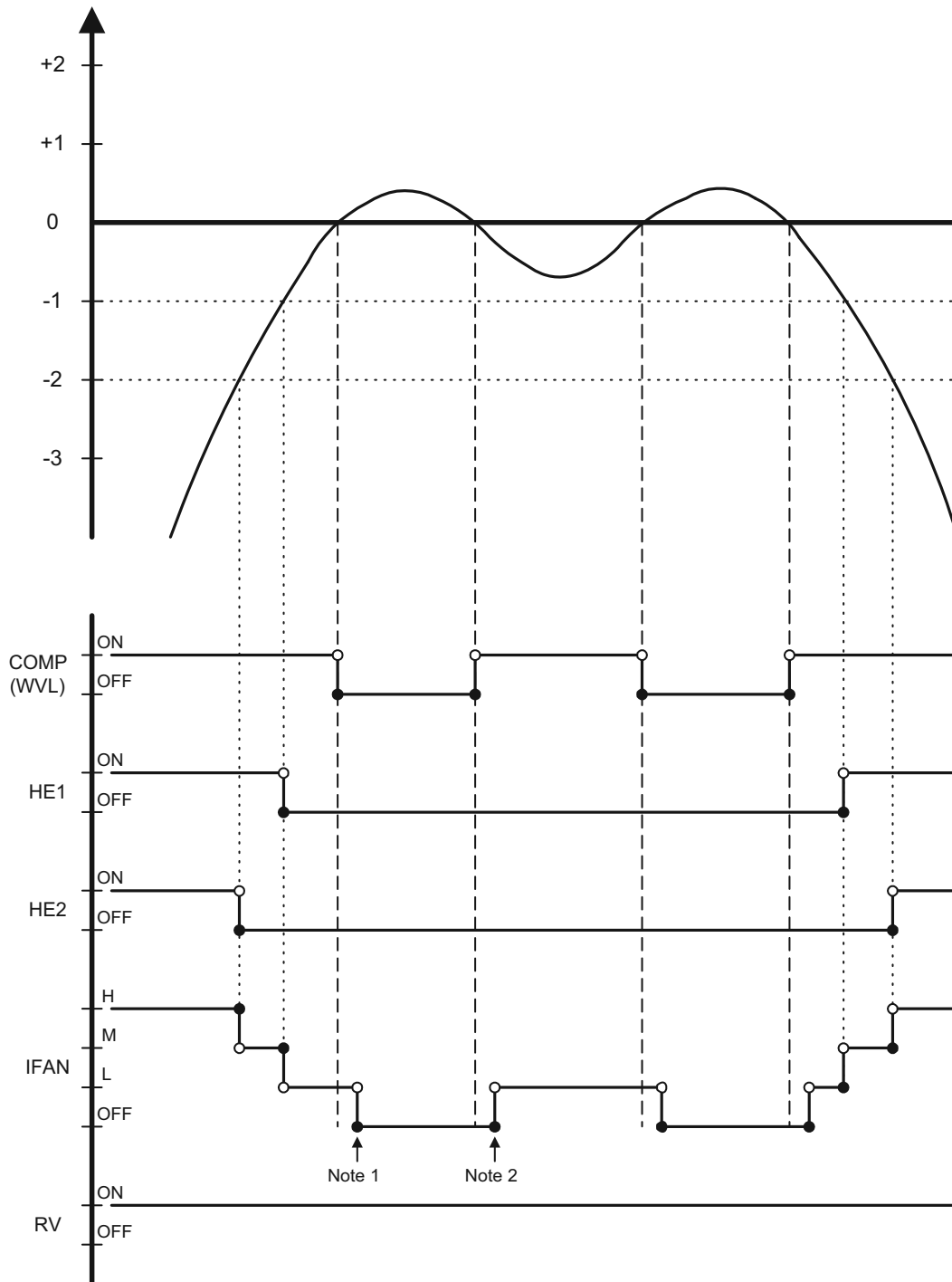

12.5.6 OFAN operation is controlled by the graph below when

1. ($RAT \geq SPT - 2^{\circ}C$), AND
2. ($ICT \geq 45^{\circ}C$), AND
3. (COMP is ON)

Otherwise, OFAN runs together with COMP.

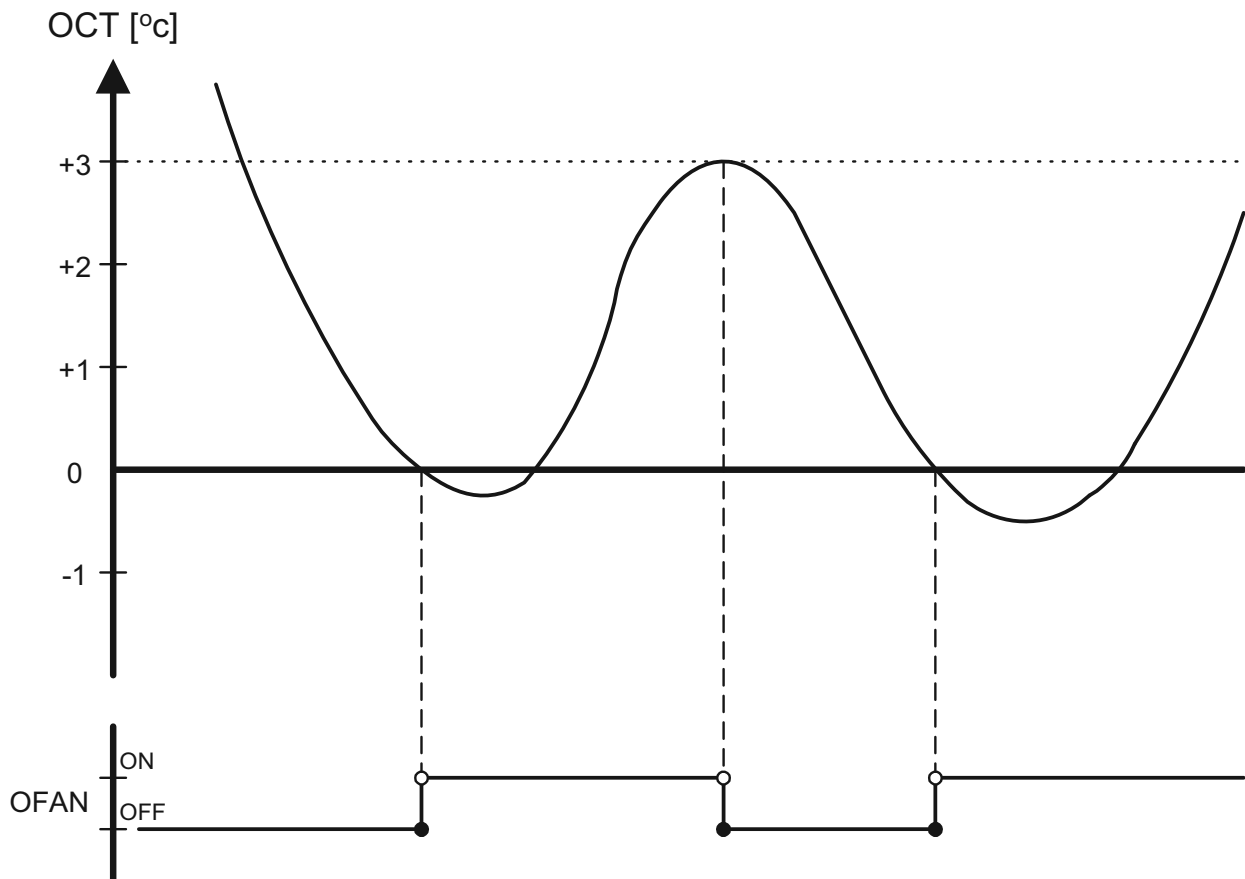

12.6 Automatic Cooling or Heating

12.6.1 Automatic Cooling or Heating - General

- Switching-temperature between Cooling and Heating is $SPT \pm 3^{\circ}\text{C}$.
- Autofan in Automatic Cooling and Heating Mode will activate “Cooling with Autofan Mode” and “Heating with Autofan Mode” respectively.
- When the Auto Mode is started with $SPT \pm 0^{\circ}\text{C}$, the unit will not select Auto Heat or Auto Cool mode immediately. Instead, the unit will be in a temporary Fan Mode with IFAN operating at low speed. The proper Auto Heat mode or Auto Cool will be started whenever the RT reaches $SPT-1^{\circ}\text{C}$ or $SPT+1^{\circ}\text{C}$ respectively.
- For RC & SH units, Mode change between Auto Heat & Auto Cool Modes is possible only after the COMP has been OFF during the last T minutes.

Mode Change	time, T
Auto Cool to Auto Heat	3 min
Auto Heat to Auto Cool	4 min

- When unit is changed from Cool/Dry mode to Auto Mode, the unit will continue to operate at (Auto) Cool Mode until the conditions for switching from Auto Cool to Auto Heat are satisfied. Similarly, when unit is changed from Heat Mode to Auto Mode, the unit will continue to operate at (Auto) Heat Mode until the conditions for switching from Auto Heat to Auto Cool are satisfied.

12.6.2 Auto Cooling or Heating, RC or SH Groups

- Mode: Auto
- Temp: Selected desired temperature
- Fan: Any
- Timer: Any
- I Feel: On or Off

Control function

Maintains room temp at desired level by selecting between cooling and heating modes.

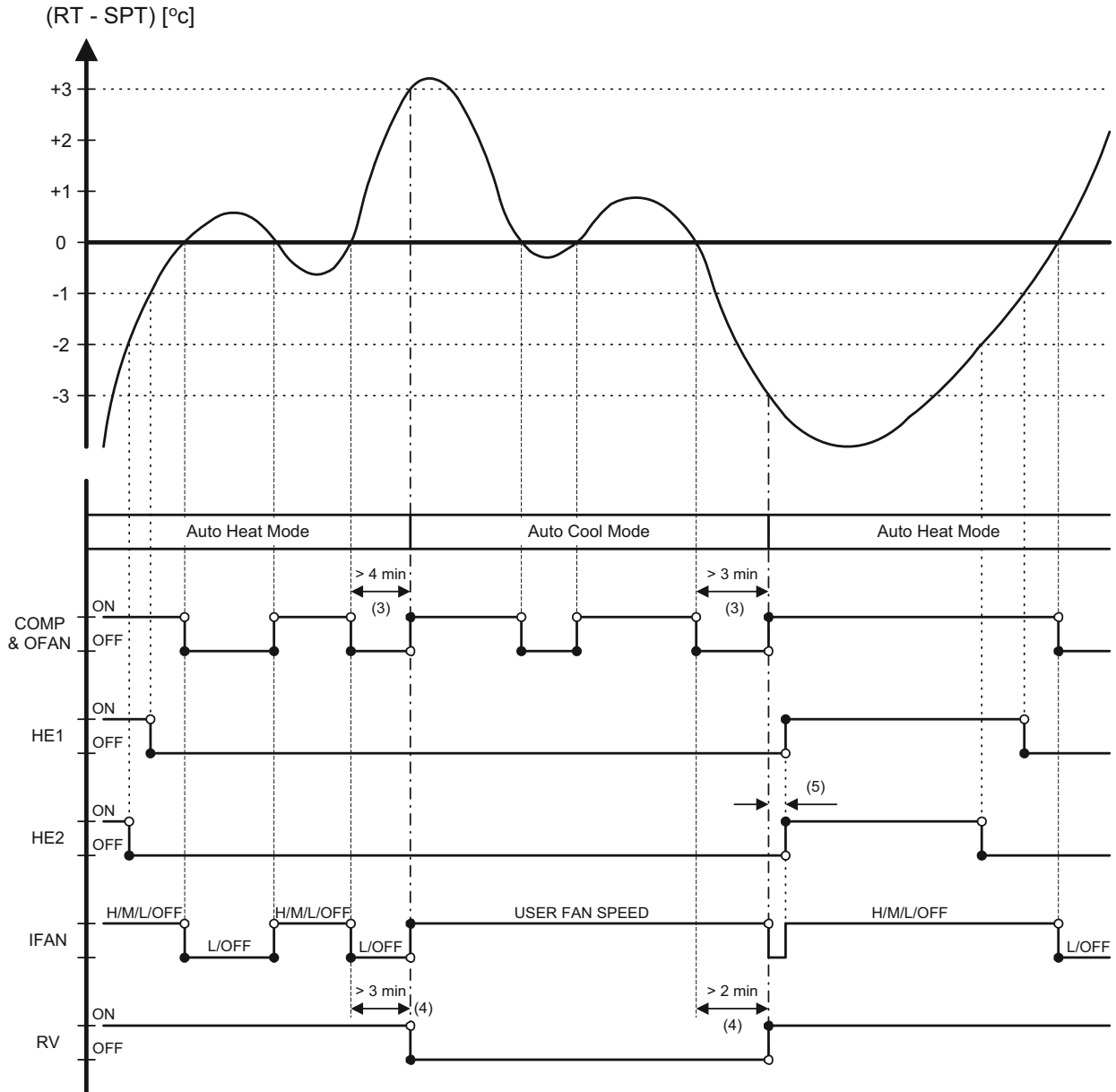

12.7 Dry Mode

12.7.1 Dry, ST or RC group

- Mode: Dry
- Temp: Selected desired temp
- Fan: Low (automatically selected by software)
- Timer: Any
- I FEEL: Any

Control function

Reduce room humidity with minimum temp. fluctuations by operating in Cool Mode with low speed IFAN.

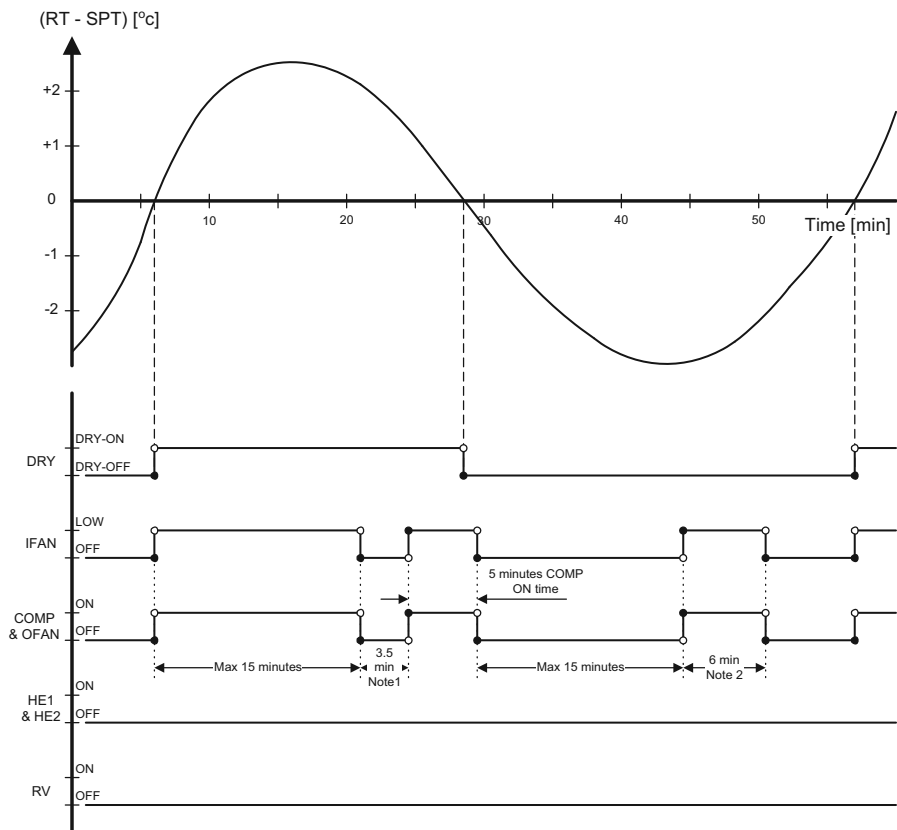

Notes :

- When Dry is ON, the COMP is forced OFF for 3.5 min (longer than the 3 min Min COMP-Off time) after every 15 min of continuous COMP operation.
- When Dry is OFF, the COMP is forced ON for 6 min (longer than the 3 min Min COMP-On time) after every 15 min of continuous COMP OFF time.
- When Dry is changed from ON to OFF or vice versa, the limits mentioned in (1) & (2) are ignored. The COMP operation is only controlled by the 3 min Min OFF time and 1 min Min ON time.
- In Dry Mode, IFAN is LOW when COMP is ON, and is OFF when COMP is OFF.

12.8 Protection

12.8.1 Cooling Mode Protections

Indoor Coil Defrost

Mode: Cooling, Dry, Auto
 Temp: Selected desired temp.
 Fan: Any
 Timer: Any
 I Feel: On or Off

Control Function

Protect the indoor coil from ice formation at low ambient temperature.

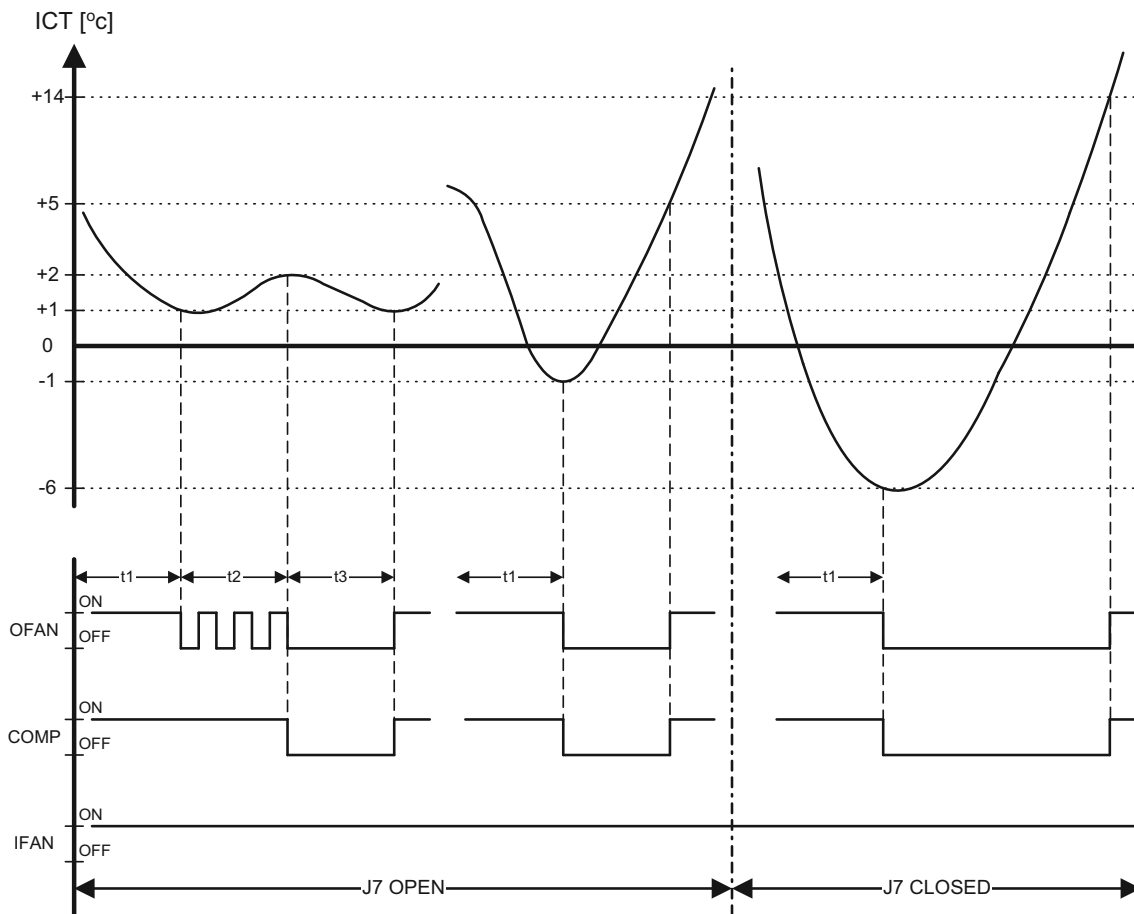

t1 = 5 min minimum for each COMP starting
 t2 = OFAN cycling (alternate between ON and OFF every 30 sec) for 20 min maximum
 t3 = COMP and OFAN stop for 10 min minimum

Notes:

- When J7 is closed (connected), OFAN cycling is cancelled and the set temperature for COMP & OFAN cut-out and cut-in are changed. COMP & OFAN are forced OFF when $ICT \leq -6^{\circ}C$, and are kept OFF until $ICT > 14^{\circ}C$.
- For WAX model, the defrost processes is simpler. When J7 is open, COMP & OFAN are forced OFF when $ICT \leq -1^{\circ}C$, and are kept OFF until $ICT > 5^{\circ}C$. When J7 is closed, the WAX defrosting process is the same as that of the other models (R.H.S. of the graph above). In both cases, the ICT checking in t2 and t3 are not applied.

12.8.2 High Pressure Protection

Mode: (Auto) Cooling or Dry
 Temp: Selected desired temp.
 Fan: Any
 Timer: Any
 I Feel: On or Off

Control Function

To protect the COMP from the high pressure built-up in the outdoor coil during normal cooling operation, by switching OFF the IFAN and COMP.

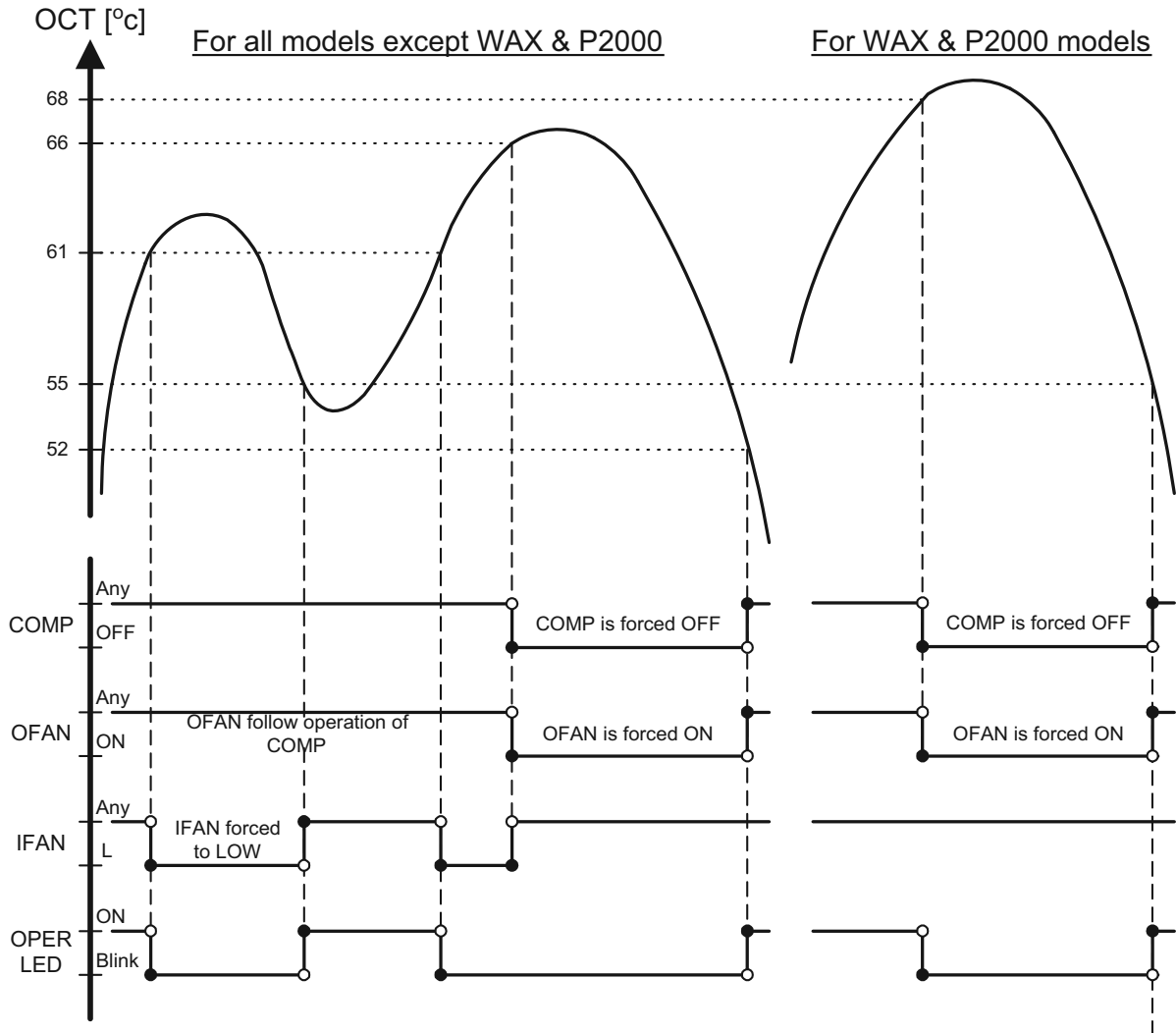

Note:

- The ICT is also monitored during Cool and Dry mode, in case the RV control circuit is faulty. Whenever ICT reaches 70°C, which indicates a high pressure in the indoor coil, the COMP will be forced off automatically. The COMP can be turned on again only after the ICT is under 70°C again and after the 3 min COMP ON delay time. The OPER LED will not blink in this case.

12.8.3 Heating Mode Protections

Outdoor coil Deicing (excluding RH Group)

Mode: Heating, Auto (at heating)

Temp: Selected desired Temp

Fan: Any

Timer: Any

I FEEL: Any

Control function

Protects the Outdoor coil from ice formation by controlling COMP & RV operation.

Scope

This new deicer is designed to operate at extreme temp conditions. The deicing cycle could be triggered from:

1. OCT temp and time between two consecutive deicing cycles.
2. Detection of ice forming by change of the OCT temp.

Both algorithms adjust the time between deicing cycles to optimize the A/C performance. The algorithm will automatically increase the time between deicing cycles and reduce the deicing cycle as needed.

The algorithm uses EEPROM data to operate.

Deicing procedure

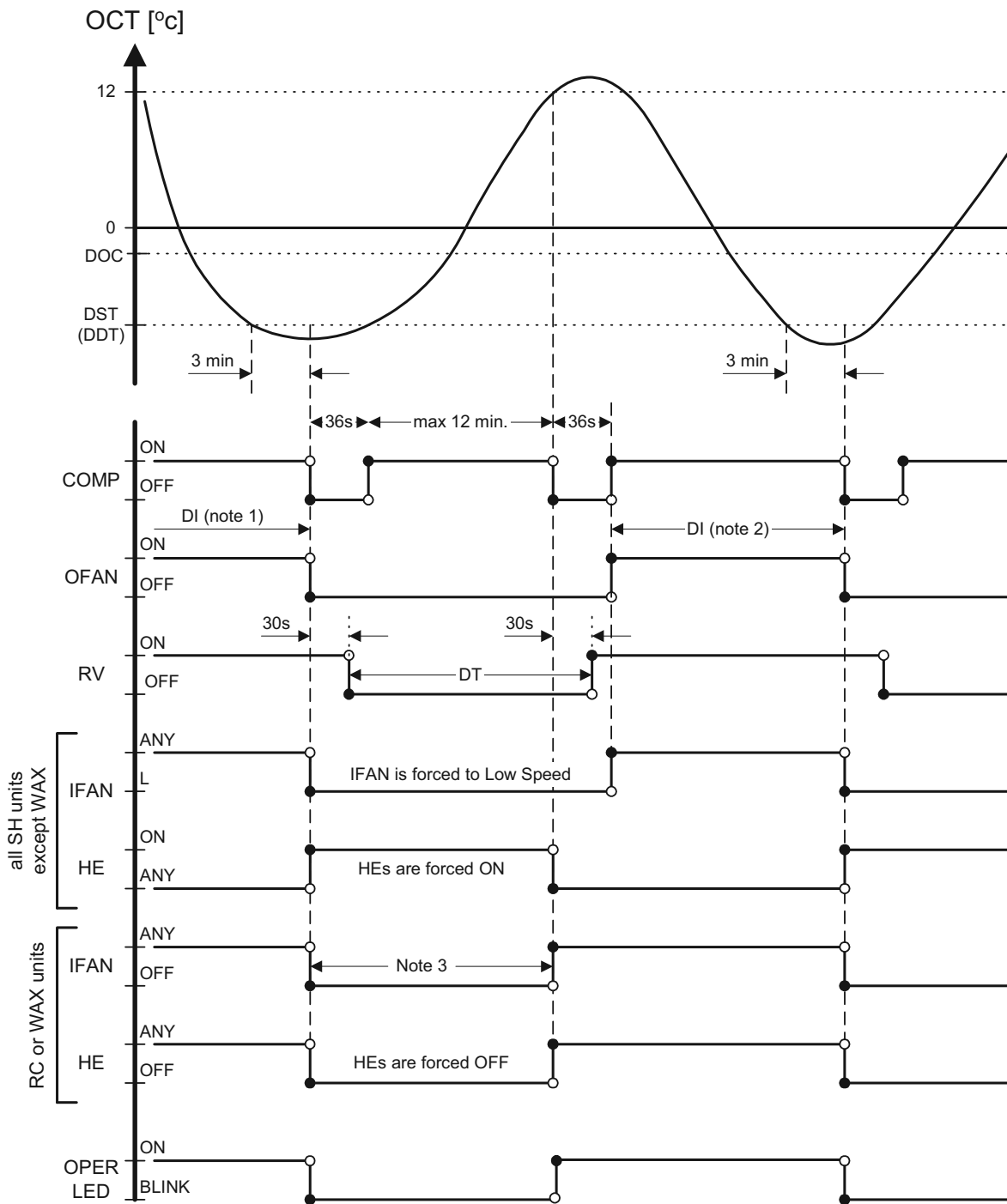

Notes :

- At the first COMP activation after SB or OFF, if (OCT < 0°C), then DI = 10 min, else DI = 40 min.
- In the following Deicing cycles, the time interval between two Deicing cycles activation is between 30 to 80 min (refer to the flow chart).
- For RC group, HEs are forced OFF. IFAN operation is as in Heat Mode, Sect 4.0.3.a, i.e. IFAN will be set to OFF when ICT < 30°C. For WAX, the IFAN is simply forced OFF.
- For SH group, HEs are forced ON and IFAN is forced to operate in Low speed, regardless of the ICT and difference between RAT & SPT.

12.8.4 High pressure protection (excluding RH Group)

Mode: (Auto) Heating
 Fan: Any
 Timer: Any
 I Feel: On or Off

Control Function

Protect the Compressor from high pressure by switching OFF the OFAN and COMP.

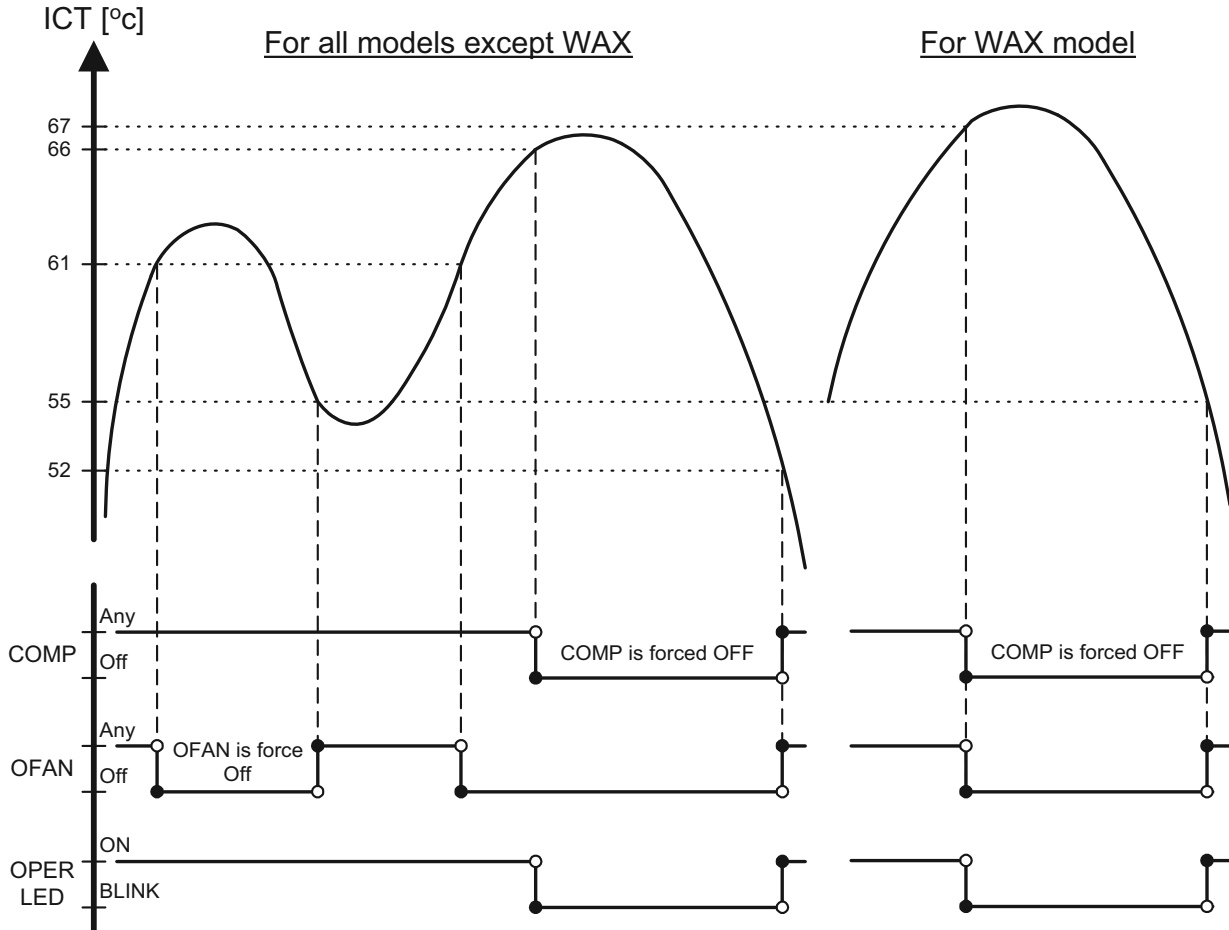

Notes:

- IFAN, HE1 and HE2 will be activated according to the relevant Heating Mode Sect.
- In case of any malfunction in the relay control circuit, the OCT is also monitored during heating mode. Whenever OCT reaches 70°C, which indicates a high pressure in the outdoor coil, the COMP will be forced off automatically. The COMP can be turned on again only after the 3 min COMP ON delay and the OCT is under 70°C. The OPER LED will not blink in this case.

12.9 Timer

Mode: Any
Temp. Selected desired temp
Fan: Any
Timer: Timer On, Timer Off
I Feel: On or Off

Control function

- Starts or stops the unit operation after pre-set time. If RC-1 is used, the timer setting will be (0.5 - 24 Hr) from the moment the timer is set. The minimum resolution is 30 minutes.
If RC-2 or later version of remote controls is used, the timer setting will be (0:00 - 23:50) real time with 10 minutes resolution.

- After power failure, all pre-set timers are cleared. The system is forced to STBY mode and the Timer LED indicator is blinked to indicate the situation. The LED keeps blinking until the timer settings can be reloaded from a R/C message.

Note: If all timers are inactive, the system will not be forced OFF after the power failure. The last OPER/STBY status will be loaded from the EEP instead.

- When the A/C receives any valid message from a R/C, the current ON/OFF timer settings will be replaced by the new timer settings in the R/C message.

Note: The following timer related operations will not affect the A/C operating mode (Heat/Cool/Auto/Dry/Fan) setting.

- Set ON/OFF timer
- Clear ON/OFF timer
- R/C ON Timer is time-up
- R/C OFF Timer is time-up

E.g. When a STBY A/C unit (with Cool Mode setting in its EEP) is turned on by the ON-TIMER of a R/C with heat mode setting, the A/C will start in Cool Mode.

12.10 Forced Operation

Forced operation allows units to start, stop and operate in Cooling or Heating in pre-set temperature according to the following table:

Forced operation mode	Pre-set Temp for : WMZ, WMF, WNG models
Cooling	22°C
Heating	28°C

Note:

- While under the forced operation, the temperature compensation schedule.
- The forced operation is activated when the mode button on the Display Board is used to switch the unit to Cool or Heat mode.
- The IFAN is always set to Autofan Speed in forced operation.

12.11 Sleep Mode

- Mode: Any
- Temp: Set – desired temperature selected
- Fan: Any
- Timer: Interact with Sleep Timer as described in sect 12.2
- I Feel: On or Off

The Sleep mode is activated by using the sleep button on the R/C. In Sleep Mode, the unit will automatically adjust the SPT to turn up/down the room temperature (RT) gradually to provide maximum comfort to the user in sleep.

Sleep is treated as TIMER function. Therefore, the TIMER LED is activated similar to TIMER function.

12.11.1 Adjustment in Sleep Mode

1. in cool, auto cool or dry modes, the SPT adjustment is positive (from 0 to +3°C).
2. In heat or auto heat modes, the SPT adjustment is negative (from 0 to -3°C).
3. In other modes, there is no SPT adjustment.
4. The SPT adjustment is cancelled when the Sleep mode is cancelled.

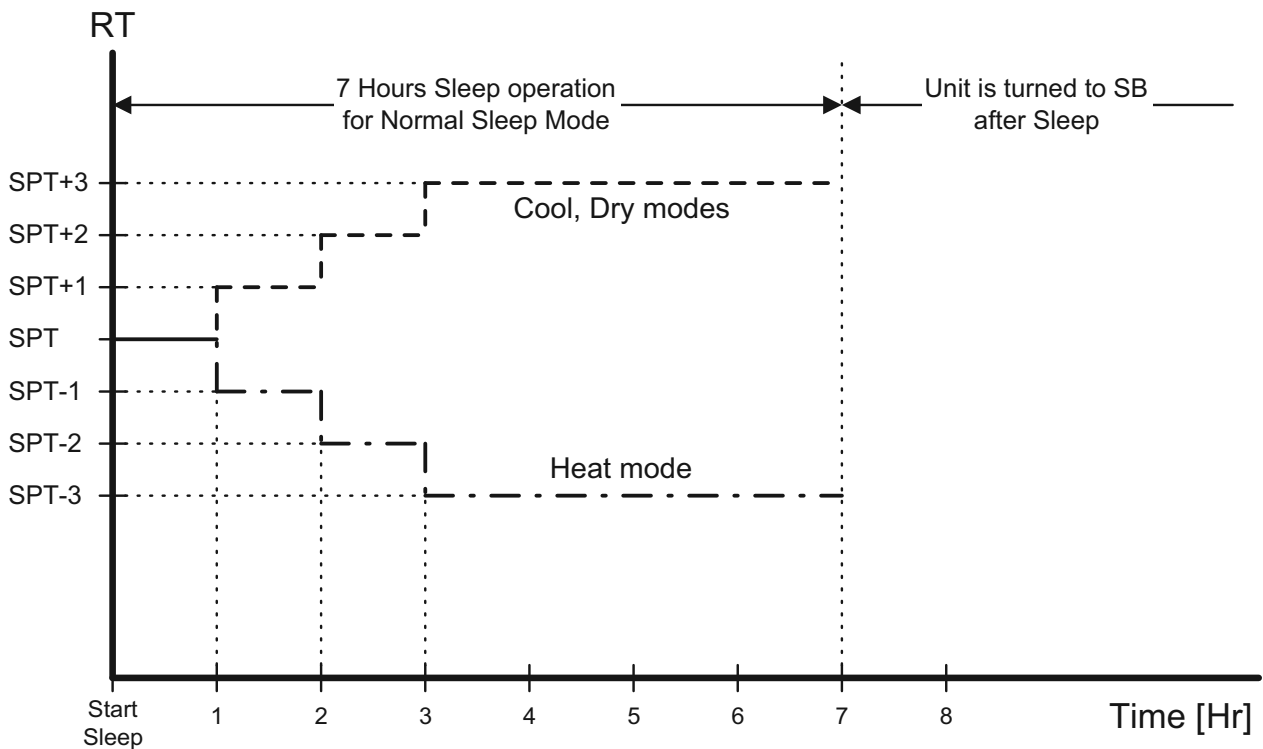

Note: If Off-timer is active, the unit may go to SB before or after 7 hours of sleep operation.

12.11.2 Time adjustment in Sleep Mode

The user can make use of the Off-Timer to extend the Sleep Time from 7 hours to 12 hour (max). The operation of the new "Extended Sleep Mode" is illustrated by the graphs below.

Case 1 is the Standard Sleep Mode, which is the only sleep mode in previous version of MCU. The A/C unit simply works for 7 hours, then goes to SB.

Case 2 is the new Extended Sleep Mode. If an active Off-Timer is set to turn off the A/C between 7-12 hour, relative to the starting of Sleep, the Sleep time is extended.

And, instead of going to SB at the 7th hour, the A/C will work until reaching the Off-time.

Case 3 is an exception to case 2. The Sleep Mode will not be extended to the Off-Time when the Off-Timer is preceded by an On-Timer, which is also between 7-12 hour.

Case 1 : Standard Sleep Mode

Condition : Off-timer is not set or is beyond 12 hour.

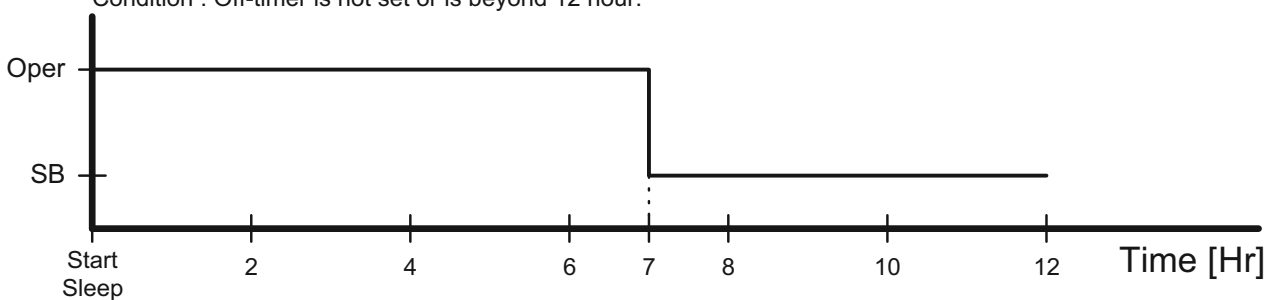

Case 2 : Extended Sleep Mode

Condition : Off-timer is set at 7-12 hour.

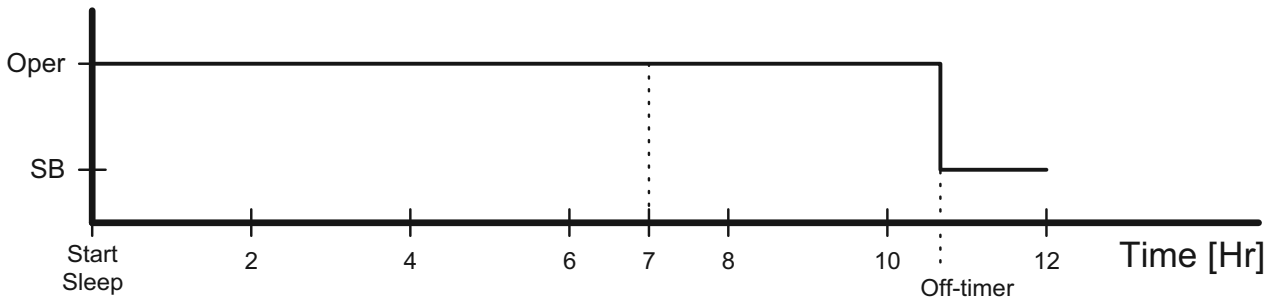

Case 3 : Exception to Case 2

Condition : Off-timer is set at 7-12 hour

On-timer is set at 7-12 hour and before Off-timer

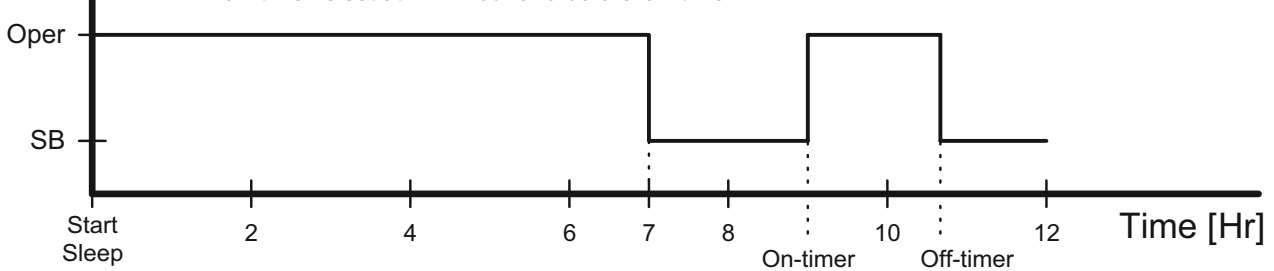

12.12 Controller Self-Test Procedure

12.12.1 By Shorting Test Jumper J1

SELF-TEST FLOW CHART
FOR CONTROLLER (VERSION 4V5 OR HIGHER)

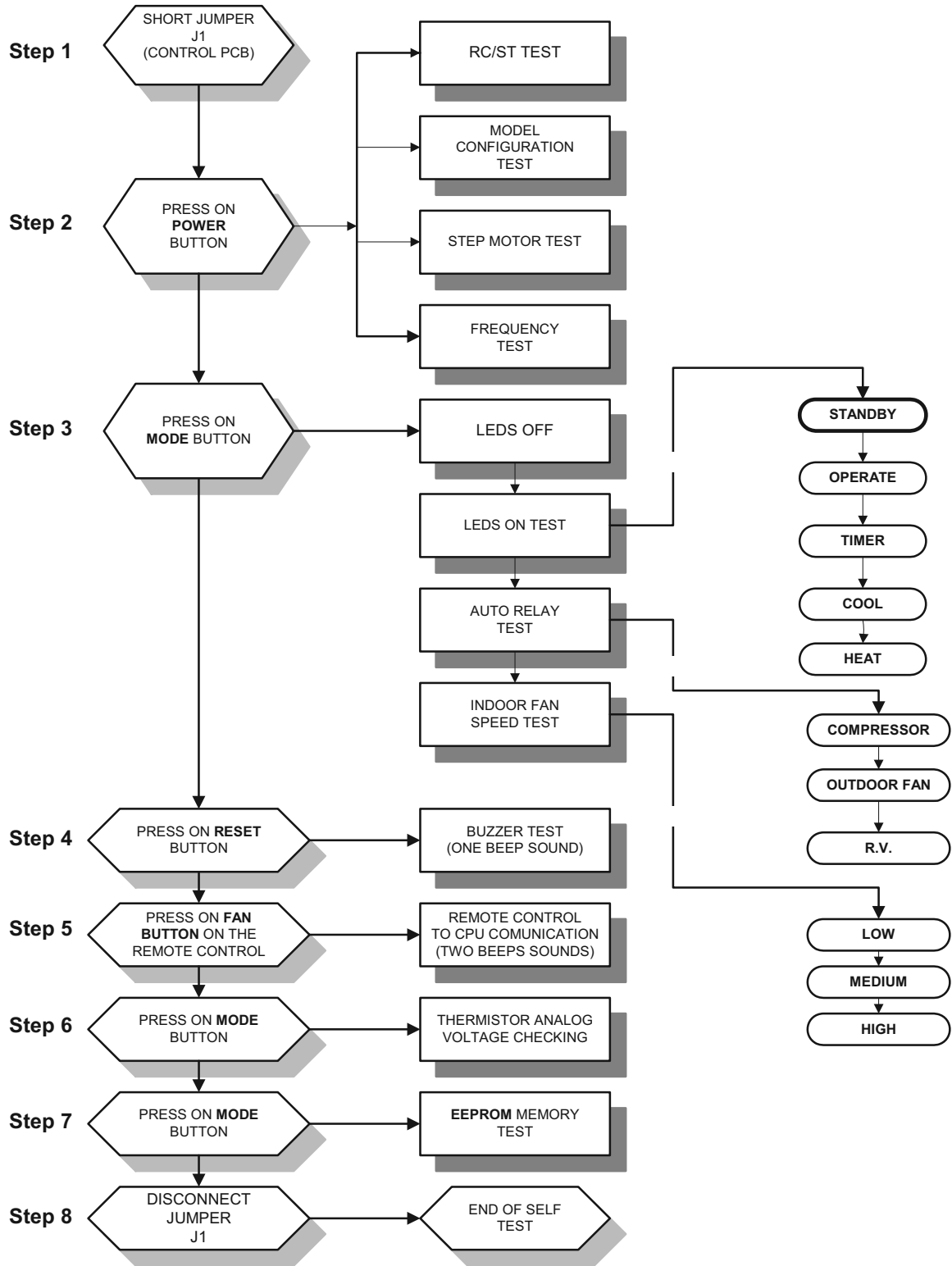

12.12.2 By Remote Control Settings:

- a. 1: TURNING ON THE POWER.
Turn ON the power, make sure that the unit is in operation.
- b. STEP 2 : ENABLE SELF-TEST MODE
 - Use the remote control to send the first settings to display / indoor unit HEAT mode, HIGH IFAN, set temperature to 16 °C, no I-FEEL Sleep or any other timer settings are needed.
 - Cover the IR transmitter components in the remote control so that it will not transmit the signals to the indoor unit display.
 - Use the remote control to send the second settings to display / indoor unit COOL mode, LOW IFAN, no I-FEEL Sleep or any other timer settings.
 - Uncover the remote control IR transmitter and change the temperature settings. If the display/indoor unit receive the settings properly the following steps will start:
- c. STEP 3: MODEL SETTING CONFIRMATION
 - The STAND-BY and COOL LEDS will indicate the operation mode as follows:

OPERATION MODE	STAND-BY LED	COOL LED
ST	ON	OFF
RC	OFF	OFF
SH	OFF	ON
RH	ON	ON

- Testing the Model configuration. Selected by the COMP, STAND-BY, TIMER LEDS and FILTER will indicate the model configuration as follows (the relevant line for this manual is highlighted):

MODEL	COMP	OPERATE LED	TIMER LED	FILTER LED
WNG	ON	OFF	OFF	OFF
WMZ	ON	ON	OFF	ON
WMN4	OFF	OFF	ON	OFF
WMN2/WHX	OFF	ON	OFF	ON
WMN3	OFF	ON	ON	ON

In this term the step motor will turn to HOME POSITION.

d. STEP 4 : AUTO LED WALK TEST.

- All the LEDS will turn OFF.
- All the LEDS will turn ON for 1 second one by one in the following sequence:
 STAND-BY ⇨ OPERATE ⇨ TIMER ⇨ FILTER ⇨ COOL ⇨ HEAT.
- In PRX all the LEDS will turn ON for 1 second one by one in the following sequence : 18 °c ⇨ 20 °c ⇨ 22 °c ⇨ 24 °c ⇨ 26 °c ⇨ 28 °c ⇨ 30 °c ⇨ High IFAN ⇨ Auto IFAN ⇨ Med IFAN ⇨ Low IFAN ⇨ STAND-BY⇨ TIMER ⇨ FILTER ⇨COOL⇨ HEAT.

e. STEP 5: AUTO REALY WALK TEST:

- All relays will energize one by one in the following sequence:
 COMPRESSOR ⇨ OUTDOOR FAN⇨R. V. ⇨ HEATER 1 ⇨ HEATER 2
 ⇨ INDOOR WATER PUMP ⇨ SWING or OUTDOOR WATER PUMP ⇨
 INDOOR FAN: LOW ⇨ MID ⇨ HIGH.
- When the relay walk test is completed, the next test will start automatically.

f. STEP 6: FREQUENCY TESTING:

- If the frequency measuring process fails the COOL LED will turn ON. In order to move to the next step, press ON/OFF button on the remote control.

g. STEP 7: INPUT TEST.

- The test purpose is to check the analog real time indicators (thermistors, LEVEL and clock) according to the table below.

LED Indicator	Condition for LED to be ON
STBY LED	Room thermistor ≠ 25°c
OPER LED	Indoor coil thermistor ≠ 25°c
TIMER LED	Outdoor coil thermistor ≠ 25°c
FILTER LED	Clock
COOL LED	LEVEL 2&3
HEAT LED	LEVEL 4

h. STEP 8: TIMING RESET TEST (WATCH DOG).

- The test purpose is to verify that the CPU rise time after power failure is between 1 to 3 sec, test results are indicated on the LEDS : STAND-BY,OPER, TIMER and FILTER turning ON one by one.
- The results of the test are coded as follows:
 Pass condition:
 1 sec - STAND-BY and OPER are turned ON
 2 sec - STAND-BY, OPER and TIMER are turned ON

Fail condition:

0 sec - STAND-BY is turned ON

3 sec - STAND-BY, OPER, TIMER and FILTER are turned ON

- When the timing reset test is completed, the next test will start automatically.

i. STEP 9: MEMORY TEST (EEPROM)

- The test purpose is to check if the memory is functioning correctly. The test result is reported by using the STAND-BY and FILTER LEDS:

LED Indicator	Condition for LED to be ON
STAND-BY LED	Test passed
FILTER LED	Test failed

AT THIS POINT THE SELF-TEST IS COMPLETED.

In order to terminate Self-Test mode the User can change the unit setting from COOL Mode, LOW FAN to COOL Mode, MED FAN or to wait without using the remote control for 60 sec.

Values of Sensors Temperature VS. Voltage (DC)

Temp. (*C)	Voltage (V)	Temp. (*C)	Voltage (V)	Temp. (*C)	Voltage (V)	Temp. (*C)	Voltage (V)
-20	4.554	2	3.744	24	2.555	46	1.487
-19	4.529	3	3.695	25	2.5	47	1.447
-18	4.502	4	3.646	26	2.445	48	1.409
-17	4.475	5	3.595	27	2.391	49	1.371
-16	4.446	6	3.544	28	2.338	50	1.334
-15	4.417	7	3.492	29	2.284	51	1.298
-14	4.386	8	3.439	30	2.232	52	1.263
-13	4.354	9	3.386	31	2.18	53	1.228
-12	4.322	10	3.332	32	2.128	54	1.195
-11	4.287	11	3.278	33	2.077	55	1.162
-10	4.252	12	3.223	34	2.027	56	1.13
9	4.216	13	3.168	35	1.978	57	1.099
-8	4.178	14	3.113	36	1.929	58	1.069
-7	4.14	15	3.058	37	1.881	59	1.04
-6	4.1	16	3.002	38	1.834	60	1.011
-5	4.059	17	2.946	39	1.798	61	0.983
-4	4.017	18	2.89	40	1.742	62	0.956
-3	3.974	19	2.833	41	1.698	63	0.929
-2	3.93	20	2.777	42	1.654	64	0.904
-1	3.885	21	2.722	43	1.611	65	0.879
0	3.839	22	2.666	44	1.569	66	0.854
1	3.792	23	2.61	45	1.527	67	0.831

12.13 On Unit Indicators and Controls

<p>STAND BY INDICATOR</p>	<p>Lights up when the Air Conditioner is connected to power and ready to receive the R/C commands Blinks continuously in case of any thermistor failure.</p>
<p>OPERATION INDICATOR</p>	<p>Lights up during operation. Blinks for 300 ms, to announce that a R/C infrared signal has been received and stored. Blinks continuously during</p> <ul style="list-style-type: none"> • OCT High Pressure Protection Mode • ICT High Pressure Protection Mode • Deicing in Heating Mode • Water Over Flow in ECC Model
<p>MODE BUTTON (Cool, Heat, SB)</p>	<p>Use to cycle the operation mode of the A/C unit among COOL, HEAT and SB modes, without using the R/C. Every time this switch is pressed, the next operation mode is selected, in this order : SB → Cool Mode → Heat Mode → SB → ... Press this button continuously for 5 sec or more to start the Diagnostic Mode.</p>

12.14 Clock Random Delay From 0 to 2.5 seconds

- 0 = Clock Switch Open
1 = Clock Switch close

The Clock is activate according to the following table:

A/C STATE (before clock is changed)	CLOCK STATE (before clock is changed)	CLOCK ACTION (clock is changed)	A/C NEW STATE (after clock is changed)
ON	1	0	OFF
OFF	0	1	ON
OFF by interrupt ⁽¹⁾	1	0	OFF
ON by interrupt ⁽¹⁾	0	1	ON

Notes :

- Clock can be interrupted by :
 - R/C - POWER ON/OFF Push-button.
 - R/C - TIMER.
 - R/C - SLEEP.
 - A/C - MODE SWITCH.
- Any change in the CLOCK level during the first 6 sec after the system Reset is ignored.

13. TROUBLESHOOTING

NO	SYMPTON	PROBABLE CAUSE	CORRECTIVE ACTION
1.	The stand-by indicator (red led) on the central control display panel doesn't light up.	There is no correct voltage between the line and neutral terminals on main P.C.B	-If the voltage is low repair power supply. -If there is no voltage repair general wiring. -If there is correct voltage replace main or display P.C.B'S
2.	The operation indicator (green led) on the central control display panel does not light up.	The remote control batteries are discharged	-Replace batteries of the remote control.
3.	The operation indicator (green led) does not light up when starting from unit.	Check main P.C.B and display P.C.B	-Replace P.C.B if necessary.
4.	The indoor fan does not function correctly.	Check the voltage between indoor fan terminals on the main P.C.B	-If there is voltage replace capacitor or motor.
5.	The outdoor fan does not function correctly.	Check the voltage between outdoor fan terminals on the main P.C.B There is voltage between outdoor fan terminals on the outdoor unit. There is no voltage between outdoor fan terminals on the outdoor unit.	-If there is no voltage replace main P.C.B -Replace capacitor or motor. -Check and repair electrical wiring between indoor and outdoor units.
6.	The compressor does not start up.	Check voltage on compressor terminals on the outdoor unit. (with ammeter) Check if there is correct voltage between compressor terminals on the outdoor unit.	-If no voltage replace main P.C.B -If low voltage repair power supply. -If the voltage correct replace capacitor or compressor. -If there is no voltage repair electrical wiring between indoor and outdoor units.
7.	The refrigeration system does not function correctly.	Check for leaks or restrictions. With ammeter. Pressure gauge or surface thermometer.	-Repair refrigeration system and charge refrigerant if necessary.

NO	SYMPTON	PROBABLE CAUSE	CORRECTIVE ACTION
8	No cooling or heating only indoor fan works.	Outdoor fan motor faulty or other fault caused, compressor overload protection cut out.	-Replace P.C.B. -Outdoor fan blocked remove obstructions.
9.	Only indoor fan and compressor working.	Outdoor fan blocked.	-Remove obstructions.
10.	Only indoor fan working.	-Run capacitor of outdoor fan motor faulty. -Windings of outdoor fan are shorted.	-Replace capacitor. -Replace motor.
11.	No cooling or heating takes place, indoor fans working.	-Overload safety device on compressor is cut out (low voltage or high temperature). -Compressor runs capacitor faulty. -Compressor windings are shorted.	-Check for proper voltage, switch off power and try again after one hour. -Replace compressor capacitor. -Replace compressor.
12.	No air supply at indoor unit, compressor operates.	-Indoor fan motor is blocked or turns slowly. -Indoor fan run capacitor faulty. -Motor windings are shorted.	-Check voltage, repair wiring if necessary. -Check fan wheel if it is tight enough on motor shaft, tighten if necessary.
13.	Partial, limited air supply at indoor unit.	Lack of refrigerant (will accompanied by whistling noise) cause ice formation on indoor unit coil in cooling mode.	-charge the unit after localizing leak.
14.	Water accumulates and over flow from indoor unit section.	Drain tube or spout of drain pan clogged.	-Disassemble plastic drain tube from spout of indoor unit drain pan.
15.	Water dripping from outdoor unit base, (in heating mode).	Water drain outlet is clogged.	-Open outdoor unit cover clean out water outlet clean the base inside thoroughly.
16.	Freeze-up of outdoor coil in heating mode, poor heating effect in room, indoor fan operates.	-Faulty outdoor thermistor. -Faulty control cable. -Outdoor temperature is below design conditions. -Outdoor unit air outlet is blocked.	-Replace thermistor. -Repair control cable. -Shut unit off, it cannot work properly. -Remove obstructions.
17.	Unit is in heat mode but operating in cooling.	-Faulty RV coil. -RV coil is ok valve is stuck position.	-Replace RV coil. -Replace the reversing valve.

14. EXPLODED VIEWS AND SPARE PARTS LISTS

14.1 Indoor Unit: Prime 7, 9, 12, 18

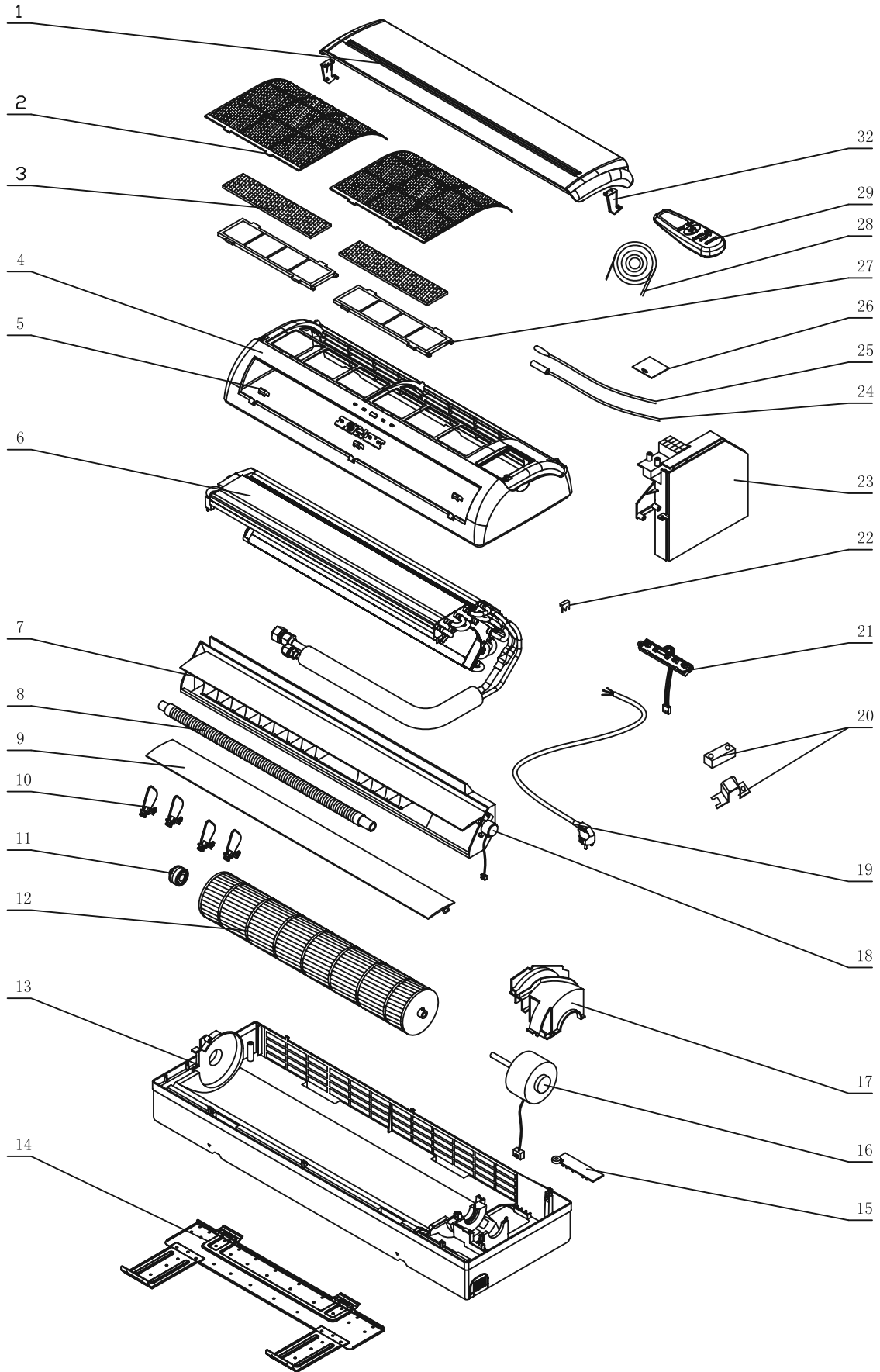

14.2 Indoor Unit Prime 9 R22 / R410A

No.	Item Code	Item Description	Quantity
1	465100013	Grill /Alpha 7,9 F	1
2	453036500	Filter for DELTA 7/9	2
4	465720055	Front Frame Assy./ AIRWELL Delta 9 fix R	1
5	4525987	SCREW COVER	3
6	4523860	Coil ASSY	1
7	452784400	IOD-7,9 Air outlet Assy. (no	1
8	4523693	DRAIN HOSE	1
9	4525991	LOUVER	1
10	4525992	VER. FLAP A	8
10	4525993	VER. FLAP B	2
11	4523526	BERAING ASSY FAN	1
12	453264200	Impeller Fan	1
13	4526659	REAR PANEL ASSY	1
14	464220008	Mount Bracket./Low Cost ALPHA 9	1
15	4526000	TUBE CLIP	1
16	4527112R	Motor Compact 12	1
17	4525998	MOTEOR COVER	1
18	4523507	Step motor	1
19	455013301R	EUR EURPowerCord/3G/1.0/2100(187)	1
20	4525988	CABLE LOCKER	1
21	453089600R	Display assy. for DELTA EHK:936A034-00	1
22	4516263	SENSOR BASE	1
23	467300198R	Controller/Delta 7/9/12 S/W:10V14	1
24	438082	Thermistor Indoor	1
25	467400024	(320mm) Indoor Air Inlet Temperature Se	1
26	453027000	Terminal Cover	1
28	4520416	Defrost cable EXPORT UNITS	1
29	436670R	R/C RC4	1
32	465440009	Frame Left Crank	1
32	465440010	Frame Right Crank	1

14.3 Indoor Unit Prime 12 R22

No.	Item Code	Item Description	Quantity
1	465100014	Grill /Alpha 12 F	1
2	453082900	Filter for DELTA 12	2
4	465720056	Front Frame Assy./ AIRWELL Delta 12 fix	1
5	4525987	SCREW COVER	3
6	462350047	Evaporator Assy./CON 12 R22	1
7	4527506	Air Outlet	1
8	4523693	DRAIN HOSE	1
9	4527509	Horizontal Flap	1
10	4525992	VER. FLAP A	9
10	4527510	Vertical Flap B	3
11	4523526	BERAING ASSY FAN	1
12	4527111	FAN ASSY PLASTIC	1
13	4527186	IOD-12 REAR PANEL ASSY	1
14	464220007	Mount Bracket./Low Cost ALPHA 12	1
15	4527512	Tube Clip	1
16	4527112R	Motor Compact 12	1
17	4525998	MOTEOR COVER	1
18	4523507	Step motor	1
19	455013301R	EUR EURPowerCord/3G/1.0/2100(187)	1
20	4525988	CABLE LOCKER	1
21	453089600R	Display assy. for DELTA EHK:936A034-00	1
22	4516263	SENSOR BASE	1
23	467300198R	Controller/Delta 7/9/12 S/W:10V14	1
24	438082	Thermistor Indoor	1
25	467400024	(320mm) Indoor Air Inlet Temperature Se	1
26	453027000	Terminal Cover	1
28	4520416	Defrost cable EXPORT UNITS	1
29	436670R	R/C RC4	1
32	465440009	Frame Left Crank	1
32	465440010	v	1

14.4 Indoor Unit: Prime 12 (class A) R410A

No.	Item Code	Item Description	Quantity
1	465100014	Grill /Alpha 12 F	1
2	453082900	Filter for DELTA 12	2
4	465720056	Front Frame Assy./ AIRWELL Delta 12 fix	1
5	4525987	SCREW COVER	3
6	453058200	Evap. System Assy./Alfa12	1
7	4527506	Air Outlet	1
8	4523693	DRAIN HOSE	1
9	4527509	Horizontal Flap	1
10	4525992	VER. FLAP A	9
10	4527510	Vertical Flap B	3
11	4523526	BERAING ASSY FAN	1
12	4527111	FAN ASSY PLASTIC	1
13	4527186	IOD-12 REAR PANEL ASSY	1
14	464220007	Mount Bracket./Low Cost ALPHA 12	1
15	4527512	Tube Clip	1
16	4527112R	Motor Compact 12	1
17	4525998	MOTEOR COVER	1
18	4523507	Step motor	1
19	455013301R	EUR EURPowerCord/3G/1.0/2100(187)	1
20	4525988	CABLE LOCKER	1
21	453089600R	Display assy. for DELTA EHK:936A034-00	1
22	4516263	SENSOR BASE	1
23	467300198R	Controller/Delta 7/9/12 S/W:10V14	1
24	438082	Thermistor Indoor	1
25	467400024	(320mm) Indoor Air Inlet Temperature Se	1
26	453027000	Terminal Cover	1
28	4520416	Defrost cable EXPORT UNITS£©	1
29	436670R	R/C RC4	1
32	465440009	Frame Left Crank	1
32	465440010	Frame Right Crank	1

14.5 Indoor Unit: Prime 12 (class C) R410A

No.	Item Code	Item Desc	Quantity
1	465100014	Grill /Alpha 12 F	1
2	453082900	Filter for DELTA 12	2
4	465720056	Front Frame Assy./ AIRWELL Delta 12 fix	1
5	4525987	SCREW COVER	3
6	470680012	Evaporator List/Low Cost ALPHA 12 R410A	1
7	4527506	Air Outlet	1
8	4523693	DRAIN HOSE	1
9	4527509	Horizontal Flap	1
10	4525992	VER. FLAP A	9
10	4527510	Vertical Flap B	3
11	4523526	BERAING ASSY FAN	1
12	4527111	FAN ASSY PLASTIC	1
13	4527186	IOD-12 REAR PANEL ASSY	1
14	464220007	Mount Bracket./Low Cost ALPHA 12	1
15	4527512	Tube Clip	1
16	4527112R	Motor Compact 12	1
17	4525998	MOTEOR COVER	1
18	4523507	Step motor	1
19	467000000R	Power Cord Without Plug 3*1.0mm2 L=2100	1
20	4525988	CABLE LOCKER	1
21	453089600R	Display assy. for DELTA EHK:936A034-00	1
22	4516263	SENSOR BASE	1
23	467300198R	Controller/Delta 7/9/12 S/W:10V14	1
24	438082	Thermistor Indoor	1
25	467400024	(320mm) Indoor Air Inlet Temperature Se	1
26	453027000	Terminal Cover	1
28	4520416	Defrost cable EXPORT UNITS£©	1
29	436670R	R/C RC4	1
32	465440009	Frame Left Crank	1
32	465440010	Frame Right Crank	1

14.6 Indoor Unit:Prime 18 R22 / R410A

No.	Item Code	Item Description	Quantity
1	465100015	Grill /Alpha 17 F	1
2	453080800	Filter	2
3	470500003	FilterAssy.	1
4	465720123	Front Frame Assy./Delta 17 Fixed RPM/Air	1
5	453081000	Screw Cover	3
6	453102200	Evaporator Assy.	1
7	453081100	Air Outlet Frame	1
8	4518664	Drain hose	1
9	4527509	Horizontal Flap	1
10	453081400	Vertical Flap A	11
10	453081500	Vertical Flap B	1
11	4518662	Bearing assy fan	1
12	453082400	Impeller Fan	1
13	453101400	Unit Housing Assy./ALPHA-17	1
14	453081900	Mount Bracket Assy.	1
15	4526000	TUBE CLIP	1
16	453102100R	ResinMotor/18W/1200rpm1000rpm	1
17	452918800	Cover/motor	1
18	4523507	Step motor	1
19	455013700R	PowerCordWithoutPlug/3G/1.5/2100(187)	1
20	4525988	CABLE LOCKER	1
21	467300007R	Display Board Assy./DELTA EHK: 936A035-0	1
22	4516263	SENSOR BASE	1
23	467300199R	Controller/Delta 17/22 S/W:10V14	1
24	438082	Thermistor Indoor	1
25	467400024	(320mm) Indoor Air Inlet Temperature Se	1
26	453027000	Terminal Cover	1
28	4520416	Defrost cable EXPORT UNITS£©	1
29	436670R	R/C RC4	1
32	465440001	Grill Left Crank	1
32	465440002	Grill Right Crank	1

14.7 Outdoor Unit: CSP 9, 12 RC R410A (class C)

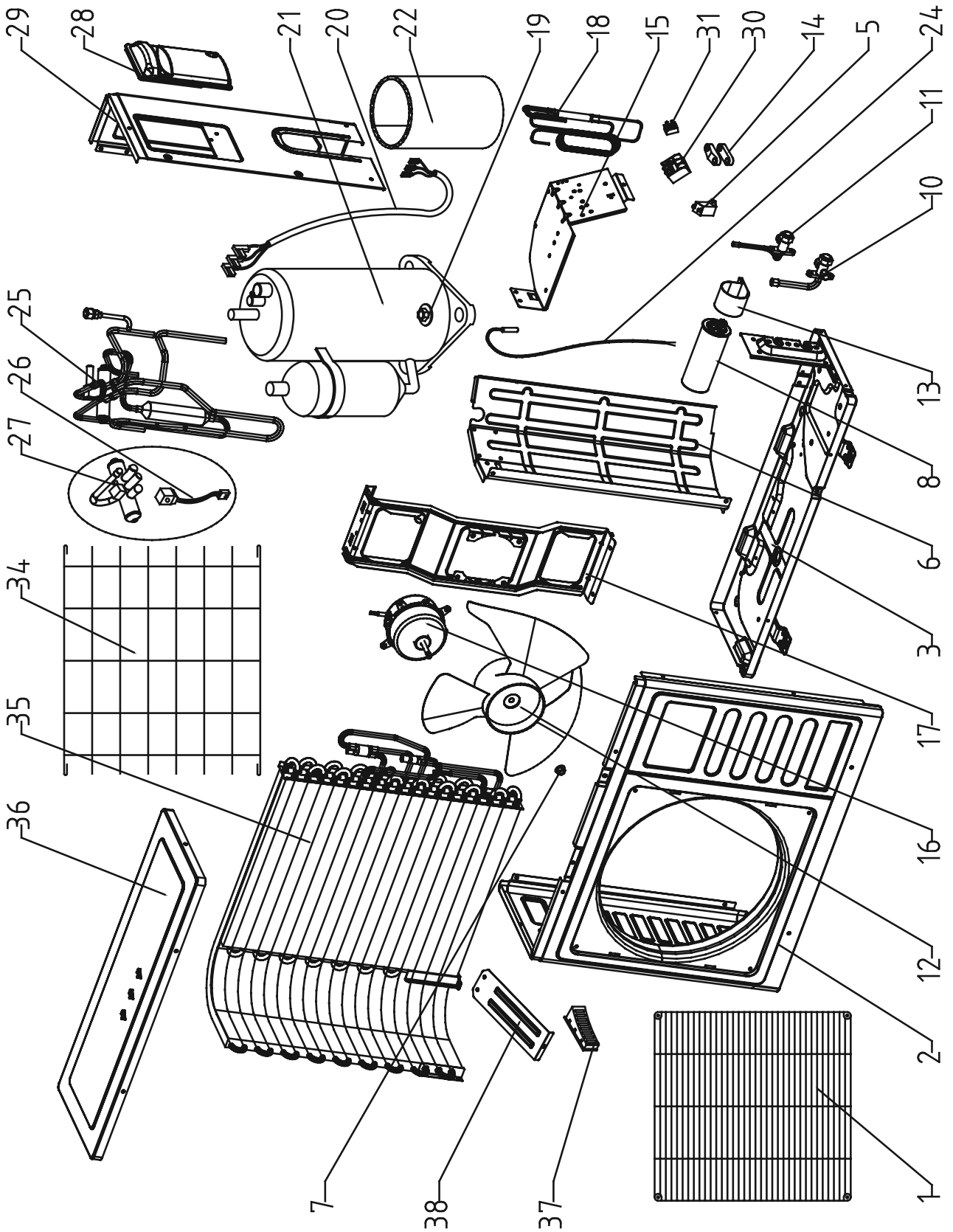

14.8 Outdoor Unit: CSP 9, RC R410A (class C)

No.	P/N	Description	Quan.
1	4526481	CON Outdoor Grille	1
2	464660013	Front panel Painting assy/CON 9/12	1
3	464600046	Base Plate Painting assy/CON 9 R410A	1
5	455000108	Double patch Capacitor for fan motor 2uF	1
6	464160019	Partition plate/CON 9/12	1
7	4510679	Nut M6 GB6187-86	1
8	455000503	Compressor Capacitor With Screw 30uF (CBB65)	1
10	461010020	Gas Valve 3/8" R410A	1
11	461000011	Liquid Valve 1/4" R410A	1
12	4523707	AXIAL FAN	1
14	204107	Cable clip Nylon	1
15	464180011	Capacitor Support/CON 9/12	1
16	466100017R	Metal Motor 20W 900rpm/Outdoor Unit	1
17	453045000	Motor support	1
18	463600026	Capillary Assy. 2.6x1.4x1200	1
19	201019	Nut M8	3
20	391498	Wire assy	1
21	460090002R	Compressor Assy./SANYO C-1RV107H1C	1
22	469100003	Insulation Felt/ Compressor	1
24	4516637	Out sensor Black	1
25	461600034	4-Way Valve Assy./CON 9 R410A	1
26	4520071	4-W valve coil for R410A	1
27	4518951	4-W valve SHF-4H for R410A	1
28	4526668	R lifter	1
29	464630010	Side Plate Painting Assy./Right/CON 9/12	1
30	4514588	5 Poles terminal block	1
31	236179	2 Poles terminal block	1
34	464800008	Guard Net Painting Assy. /CON	1
35	462300038	Condenser Assy/CON 9	1
36	4526675	TOP COVER PAINTING	1
37	436358	L. lifter	1
38	4526143	LINKER OF MOTOR SUPPORT ASSY	1

14.9 Outdoor Unit: CSP 12 RC R410A (class C)

NO.	P/N	Description	Quan.
1	4526481	CON Outdoor Grille	1
2	464660013	Front panel Painting assy/CON 9/12	1
3	464600040	Base Painting assy/ CON 12 R410A	1
5	455000108	Double patch Capacitor for fan motor 2uF	1
6	464160019	Partition plate/CON 9/12	1
7	4510679	Nut M6 GB6187-86	1
8	455000502	Compressor Capacitor With Screw 25uF (CBB65)	1
10	461010020	Gas Valve 3/8" R410A	1
11	461000011	Liquid Valve 1/4" R410A	1
12	4523707	AXIAL FAN	1
14	204107	Cable clip Nylon	1
15	464180011	Capacitor Support/CON 9/12	1
16	466100017R	Metal Motor 20W 900rpm/Outdoor Unit	1
17	453045000	Motor support	1
18	463600028	Capillary Assy.	1
19	201019	Nut M8	3
20	391498	Wire assy	1
21	460090000R	Compressor Assy./SANYO C-RV133H1D	1
22	469100003	Insulation Felt/ Compressor	1
24	4516637	Out sensor Black	1
25	461600031	4-Way Valve System Assy./ CON 12 R410A	1
26	4520071	4-W valve coil for R410A	1
27	4518951	4-W valve SHF-4H for R410A	1
28	4526668	R lifter	1
29	464630010	Side Plate Painting Assy./Right/CON 9/12	1
30	4514588	5 Poles terminal block	1
31	236179	2 Poles terminal block	1
34	464800008	Guard Net Painting Assy. /CON	1
35	462300039	Condenser Assy/CON 12 For EU	1
36	4526675	TOP COVER PAINTING	1
37	436358	L. lifter	1
38	4526143	LINKER OF MOTOR SUPPORT ASSY	1

14.10 Outdoor Unit: CSP 9, 12 ST R410A (class C)

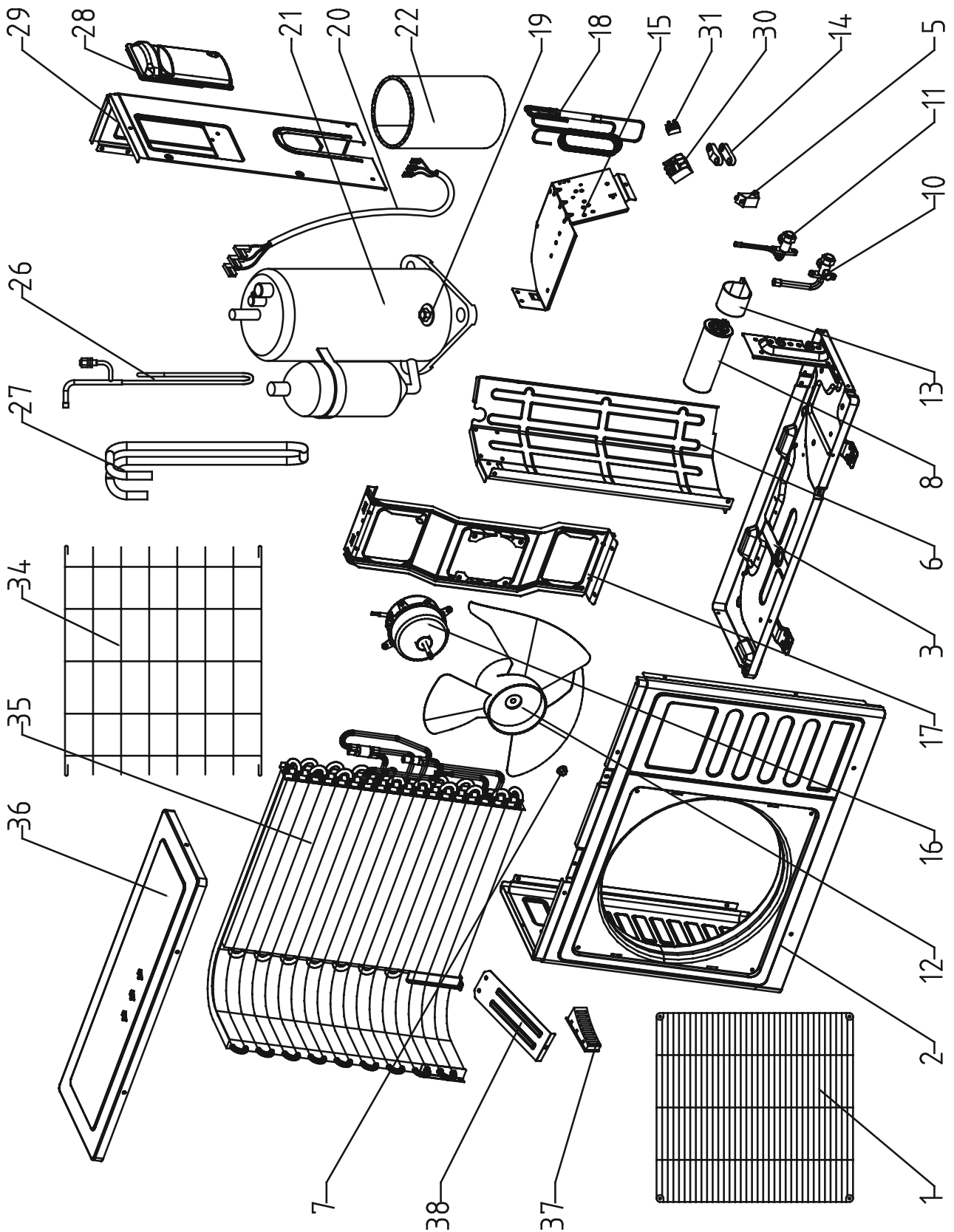

14.11 Outdoor Unit: CSP 9 ST R410A (class C)

NO.	P/N	Description	Quan.
1	4526481	CON Outdoor Grille	1
2	464660013	Front panel Painting assy/CON 9/12	1
3	464600046	Base Plate Painting assy/CON 9 R410A	1
5	455000108	Double patch Capacitor for fan motor 2uF	1
6	464160019	Partition plate/CON 9/12	1
7	4510679	Nut M6 GB6187-86	1
8	455000503	Compressor Capacitor With Screw 30uF (CBB65)	1
10	461010020	Gas Valve 3/8" R410A	1
11	461000011	Liquid Valve 1/4" R410A	1
12	4523707	AXIAL FAN	1
14	204107	Cable clip Nylon	1
15	464180011	Capacitor Support/CON 9/12	1
16	466100017R	Metal Motor 20W 900rpm/Outdoor Unit	1
17	453045000	Motor support	1
18	463600026	Capillary Assy. 2.6x1.4x1200	1
19	201019	Nut M8	3
20	391498	Wire assy	1
21	460090002R	Compressor Assy./SANYO C-1RV107H1C	1
22	469100003	Insulation Felt/ Compressor	1
26	463300375	Discharge Pipe TP2M 7.94*0.8/CON 9 ST R410A	1
27	463300377	Scution Pipe TP2M 9.53*0.8/CON 9 ST R410A	1
28	4526668	R lifter	1
29	464630010	Side Plate Painting Assy./Right/CON 9/12	1
31	236179	2 2 Poles terminal block	1
34	464800008	Guard Net Painting Assy. /CON	1
35	462300042	Condenser Assy/CON 9 ST	1
36	4526675	TOP COVER PAINTING	1
37	436358	L. lifter	1
38	4526143	LINKER OF MOTOR SUPPORT ASSY	1

14.12 Outdoor Unit: CSP 12 ST R410A (class C)

No.	P/N	Description	Quan.
1	4526481	CON Outdoor Grille	1
2	464660013	Front panel Painting assy/CON 9/12	1
3	464600040	Base Painting assy/ CON 12 R410A	1
5	455000108	Double patch Capacitor for fan motor 2uF	1
6	464160019	Partition plate/CON 9/12	1
7	4510679	Nut M6 GB6187-86	1
8	455000502	Compressor Capacitor With Screw 25uF (CBB65)	1
10	461010020	Gas Valve 3/8" R410A	1
11	461000011	Liquid Valve 1/4" R410A	1
12	4523707	AXIAL FAN	1
14	204107	Cable clip Nylon	1
15	464180011	Capacitor Support/CON 9/12	1
16	466100017R	Metal Motor 20W 900rpm/Outdoor Unit	1
17	453045000	Motor support	1
18	463600028	Capillary Assy.	1
19	201019	Nut M8	3
20	391498	Wire assy	1
21	460090000R	Compressor Assy./SANYO C-RV133H1D	1
22	469100003	Insulation Felt/ Compressor	1
26	463300376	Discharge Pipe TP2M 7.94*0.8/CON 12 ST R410A	1
27	463300378	Scution Pipe TP2M 9.53*0.8/CON 12 ST R410A	1
28	4526668	R lifter	1
29	464630010	Side Plate Painting Assy./Right/CON 9/12	1
30	4514588	5 Poles terminal block	1
34	464800008	Guard Net Painting Assy. /CON	1
35	462300043	Condenser Assy/CON 12 ST	1
36	4526675	TOP COVER PAINTING	1
37	436358	L. lifter	1
38	4526143	LINKER OF MOTOR SUPPORT ASSY	1

14.13 Outdoor Unit: CSP 9, 12 RC R22

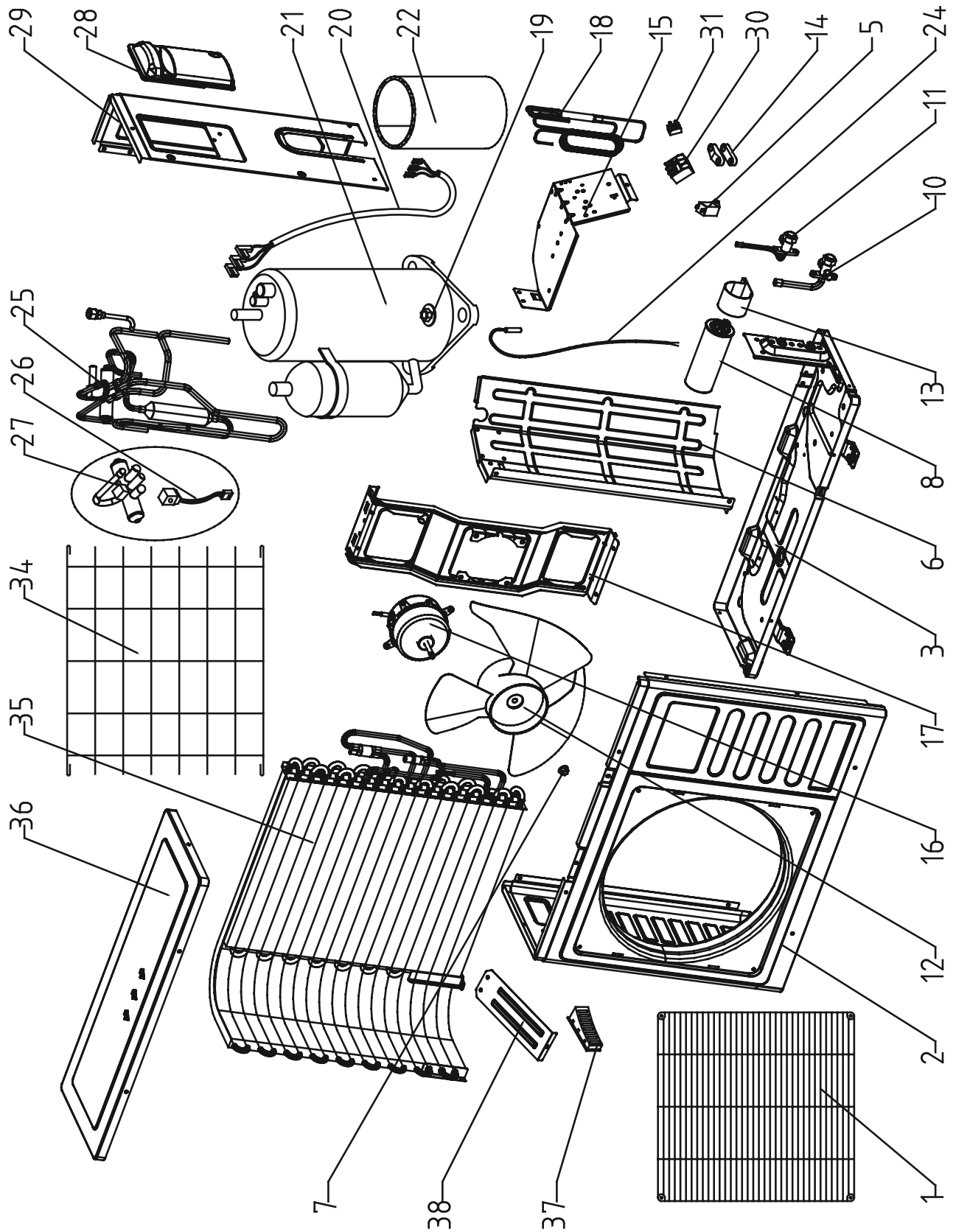

14.14 Outdoor Unit CSP 9 RC R22

No.	Item	Description	Quan.
1	4526481	CON Outdoor Grille	1
2	464660013	Front panel Painting assy/CON 9/12	1
3	464600056	Base Plate Painting Assy./CON SP 9 R22	1
5	455000108	Double patch Capacitor for fan motor 2uF	1
6	4526141	PARTITION PLATE	1
7	4510679	Nut M6 GB6187-86	1
8	455000401	Compressor Capacitor 30uF (CBB65)	1
10	4523587	GAS VALVE	1
11	4523533	Liquid Valve	1
12	4523707	AXIAL FAN	1
13	4518839	Comp. Capacitor Clip	1
14	204107	Cable clip Nylon	1
15	453044500	Pedestal/Control	1
16	466100017R	Metal Motor 20W 900rpm/Outdoor Unit	1
17	4526146	MOTOR SUPPORT ASSY	1
18	4523913	Capillary assy	1
19	201019	Nut M8	3
20	391498	Wire assy	1
21	452982000	Compressor assy PH170X1C-4DZDE3	1
22	469100003	Insulation Felt/ Compressor	1
24	4516637	Out sensor Black	1
25	4526875	4-W vavle welding assy	1
26	4514005	4-W valve coil	1
27	224213	4-W valve	1
28	4526668	R lifter	1
29	4526669	SIDE PANEL PAINTING	1
30	4514588	5 Poles terminal block	1
31	236179	2 Poles terminal block	1
34	464800008	Guard Net Painting Assy. /CON	1
35	4526651	Cond. Assy	1
36	4526675	TOP COVER PAINTING	1
37	436358	L. lifter	1
38	4526143	LINKER OF MOTOR SUPPORT ASSY	1

14.15 Outdoor Unit: CSP 12 RC R22

No.	Item	Description	Quan.
1	4526481	CON Outdoor Grille	1
2	464660013	Front panel Painting assy/CON 9/12	1
3	464600040	Base Painting assy/ CON 12 R410A	1
5	455000108	Double patch Capacitor for fan motor 2uF	1
6	464160019	Partition plate/CON 9/12	1
7	4510679	Nut M6 GB6187-86	1
8	455000502	Compressor Capacitor With Screw 25uF (CBB65)	1
10	461010021	Gas Valve 1/2" R22	1
11	461000013	Liquid Valve 1/4" R22	1
12	4523707	AXIAL FAN	1
14	204107	Cable clip Nylon	1
15	464180011	Capacitor Support/CON 9/12	1
16	466100017R	Metal Motor 20W 900rpm/Outdoor Unit	1
17	453045000	Motor support	1
18	463600030	Capillary Assy. (OD2.6xID1.6x800+450)	1
19	201019	Nut M8	3
20	391498	Wire assy	1
21	460030002R	Compressor Assy/ SANYO C-RV212H51BA	1
22	469100003	Insulation Felt/ Compressor	1
24	4516637	Out sensor Black	1
25	461600038	4-Way Valve Assy./CON12 R22	1
26	4514005	4-W valve coil	1
27	224213	4-W valve	1
28	4526668	R lifter	1
29	464630010	Side Plate Painting Assy./Right/CON 9/12	1
30	4514588	5 Poles terminal block	1
31	236179	2 Poles terminal block	1
34	464800008	Guard Net Painting Assy. /CON	1
35	462300046	Condenser Assy/CON 12 R22	1
36	4526675	TOP COVER PAINTING	1
37	436358	L. lifter	1
38	4526143	LINKER OF MOTOR SUPPORT ASSY	1

14.16 Outdoor Unit: GCN9, 12 RC R410A (class A)

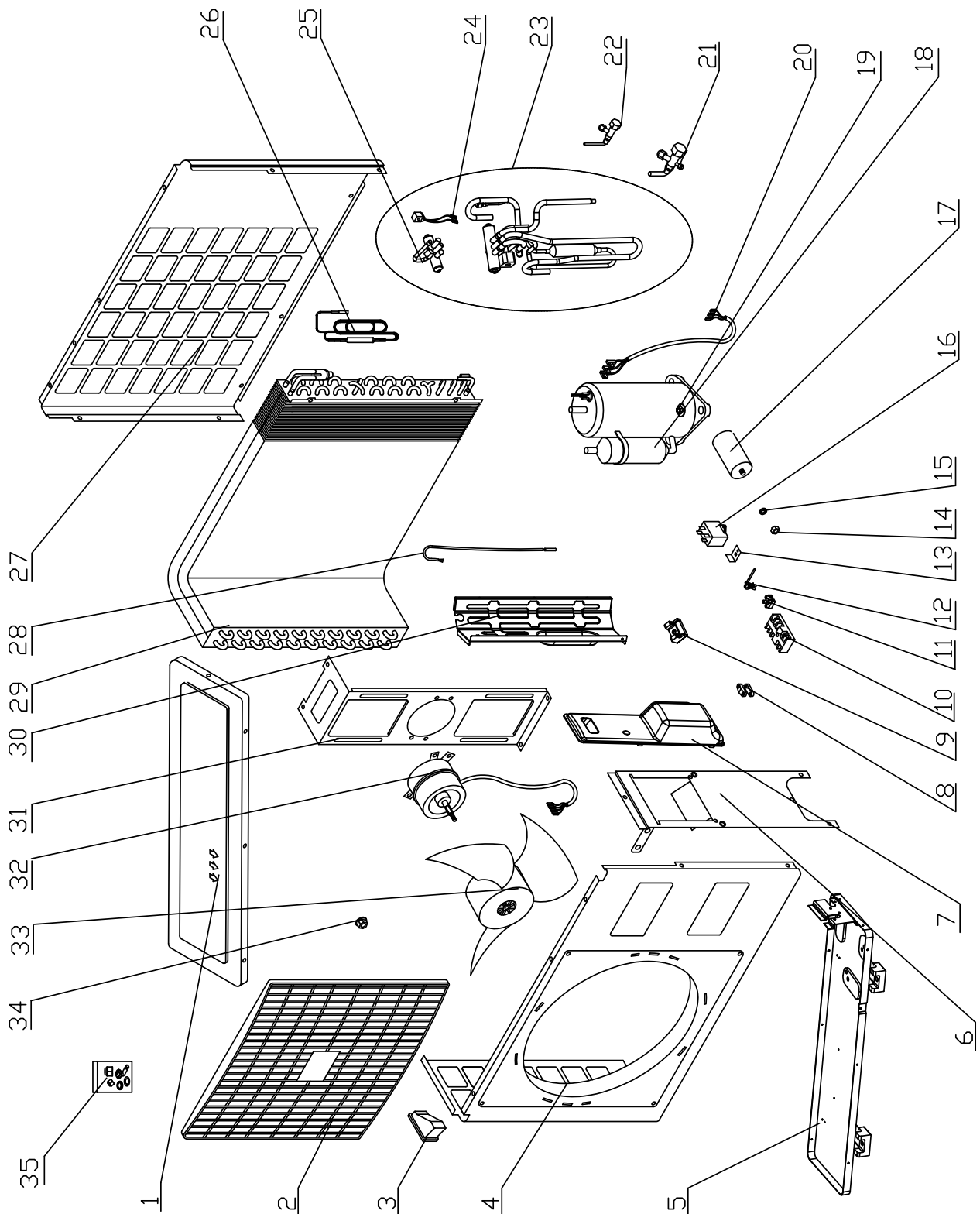

14.17 Outdoor Unit: GCN9 RC R410A (class A)

No.	Item Code	Description	Quantity
1	4516158	Cover panel Painting assy	1
2	4522551	Grille A of GCN	1
3	436358	L. lifter	1
4	4523441	Front panel A Painting assy	1
5	4516907	PAINTING BASE ASSY.	1
6	453086200	Side Plate Painting Assy.	1
7	4516857	BIG SIDE COVER	1
8	204107	Cable clip Nylon	1
9	453070800	Rubber gromet/base plate	4
10	236332	6 Poles terminal block	1
11	236179	2 Poles terminal block	1
12	253046	Clip set PVC	1
13	4518022	Cap. Clip	1
14	201130	Nut M4	1
15	203008	Washer	1
16	455000108	Double patch Capacitor for fan	1
17	455000502	Compressor Capacitor 35uF With Screw	1
18	453090300	Compressor Assy. PA108X1C-4FZ	1
19	452795300	Nut With Flange M6	3
20	391498	Wire assy	1
21	453047000	Low pressure stop valve for R410A	1
22	453046900	High pressure stop valve for R410A	1
23	453091500	4 Way Valve System Assy.	1
24	4520071	4-W valve coil for R410A	1
25	4518951	4-W valve SHF-4H for R410A	1
26	453091600	Single Valve Assy.	1
27	4516156	Rear panel Painting assy	1
28	4516637	Out sensor Black	1
29	453090700	Condenser System Assy.	1
30	464160018	Partition plate/GCZ 9/12	1
31	464860032	Motor Support Assy.	1
32	4522765R	Motor of outdoor (670/750rpm)	1
33	4519251	Axial Fan OD=400	1
34	4519300	Nut M5 L	1
35	453121500	Install. Accessory	1

14.18 Outdoor Unit: GCN12 RC R410A (class A)

No.	Item Code	Description	Quantity
1	4516158	Cover panel Painting assy	1
2	4522551	Grille A of GCN	1
3	436358	L. lifter	1
4	4523441	Front panel A Painting assy	1
5	4523862	Base Painting assy	1
6	453086200	Side Plate Painting Assy.	1
7	4516857	BIG SIDE COVER	1
8	204107	Cable clip Nylon	1
9	453070800	Rubber gromet/base plate	4
10	236332	6 Poles terminal block	1
11	236179	2 Poles terminal block	1
12	253046	Clip set PVC	1
13	4518022	Cap. Clip	1
14	201130	Nut M4	1
15	203008	Washer	1
16	455000108	Double patch Capacitor for fan	1
17	455000504	Compressor Capacitor With Screw	1
18	4526452	Comp. Assy GMCC PA145X2C-4FT	1
19	4510677	Nut With Flange M8 -D=24	3
20	391498	Wire assy	1
21	453047000	Low pressure stop valve for R410A	1
22	453046900	High pressure stop valve for R410A	1
23	453092700	4-Way Valve System Assy.	1
24	4520071	4-W valve coil for R410A	1
25	4518952	4-W valve SHF-7H for R410A	1
26	453092800	Single Valve Assy. 2.6X1.6	1
27	4516156	Rear panel Painting assy	1
28	4516637	Out sensor Black	1
29	453092100	Condenser System Assy.	1
30	464160018	Partition plate/GCZ 9/12	1
31	464860032	Motor Support Assy.	1
32	4522766R	Motor of outdoor (830rpm)	1
33	4519251	Axial Fan OD=400	1
34	4519300	Nut M5 L	1
35	453121500	Install. Accessory	1

14.19 Outdoor Unit: GCN9,12 ST R410A (class A)

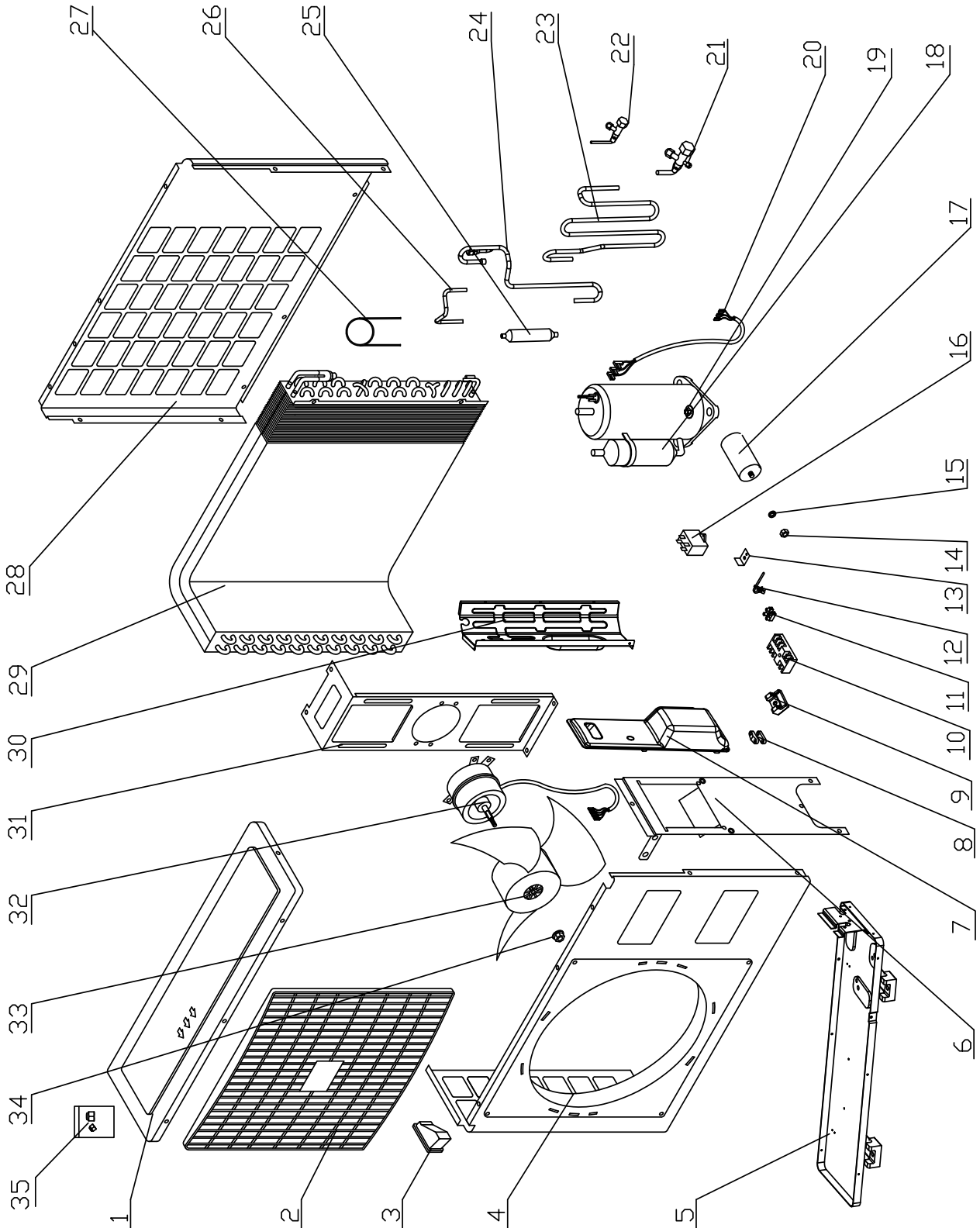

14.20 Outdoor Unit: GCN9 ST R410A (class A)

No.	Item Code	Description	Quantity
1	4516158	Cover panel Painting assy	1
2	4522551	Grille A of GCN	1
3	436358	L. lifter	1
4	4523441	Front panel A Painting assy	1
5	4516907	PAINTING BASE ASSY.	1
6	453086200	Side Plate Painting Assy.	1
7	4516857	BIG SIDE COVER	1
8	204107	Cable clip Nylon	1
9	453070800	Rubber gromet/base plate	4
10	236332	6 Poles terminal block	1
12	253046	Clip set PVC	1
13	4518022	Cap. Clip	1
14	201019	Nut M8	1
15	203008	Washer	1
16	455000108	Double patch Capacitor for fan	1
17	455000502	Compressor Capacitor 35uF With Screw	1
18	453090300	Compressor Assy. PA108X1C-4FZ	1
19	452795300	Nut With Flange M6	3
20	391498	Wire assy	1
21	453047000	Low pressure stop valve for R410A	1
22	453046900	High pressure stop valve for R410A	1
23	453086900	Scution Pipe	1
24	453087000	Discharge Pipe 1	1
25	4526865	Muffler	1
26	453091300	Discharge Pipe 2	1
27	453121700	Capillary 2.6*1.4*900	1
28	464770001	Rear Plate/Left Painting Assy	1
28	464770007	Rear Plate/Right Painting Assy/GCZ 9/12	1
28	464800000	Guard Net/ODU Painting Assy	1
29	453090700	Condenser System Assy.	1
30	464160018	Partition plate/GCZ 9/12	1
31	464860002	Motor Support Assy.	1
32	4522765R	Motor of outdoor (670/750rpm)	1
33	4519251	Axial Fan OD=400	1
34	4519300	Nut M5 L	1
35	453166600	Install. Accessory	1

14.21 Outdoor Unit: GCN12 ST R410A (class A)

No.	Item Code	Description	Quantity
1	4516158	Cover panel Painting assy	1
2	4522551	Grille A of GCN	1
3	436358	L. lifter	1
4	4523441	Front panel A Painting assy	1
5	4523862	Base Painting assy	1
6	453086200	Side Plate Painting Assy.	1
7	4516857	BIG SIDE COVER	1
8	204107	Cable clip Nylon	1
9	453070800	Rubber gromet/base plate	4
10	236332	6 Poles terminal block	1
11	236179	2 Poles terminal block	1
12	253046	Clip set PVC	1
13	4518022	Cap. Clip	1
14	201130	Nut M4	1
15	203008	Washer	1
16	455000108	Double patch Capacitor for fan	1
17	455000504	Compressor Capacitor With Screw	1
18	4526452	Comp. Assy GMCC PA145X2C-4FT	1
19	4510677	Nut With Flange M8 -D=24	3
20	391498	Wire assy	1
21	453047000	Low pressure stop valve for R410A	1
22	453046900	High pressure stop valve for R410A	1
23	453087500	Scution Pipe	1
24	453087600	Discharge Pipe 1	1
25	453091000	Muffler	1
26	453092500	Discharge Pipe 2	1
27	453121600	Capillary 2.6*1.6*900	1
28	4516156	Rear panel Painting assy	1
29	453092100	Condenser System Assy.	1
30	464160018	Partition plate/GCZ 9/12	1
31	464860032	Motor Support Assy.	1
32	4522766R	Motor of outdoor (830rpm)	1
33	4519251	Axial Fan OD=400	1
34	4519300	Nut M5 L	1
35	453166600	Install. Accessory	1

14.22 Outdoor Unit: ONG3-17 RC R410A

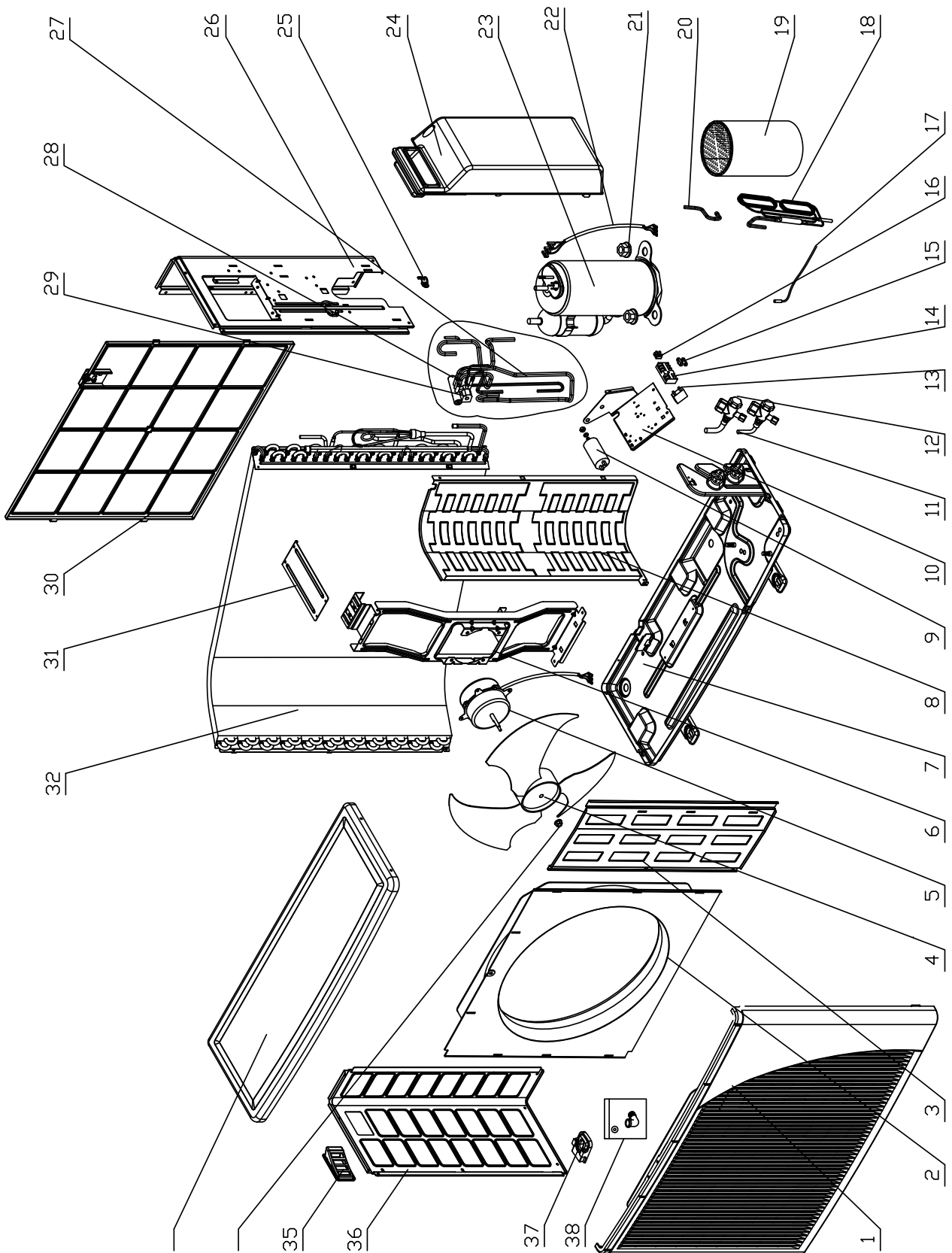

14.23 Outdoor Unit: ONG3-17 RC R410A

No.	Item Code	Item Desc	Quantity
1	433218	Front Panel A	1
2	433221	Air Inlet Ring-420	1
3	464860054	Painting Insulation Plate Assy/ONG	1
4	4519251	Axial Fan OD=400	1
5	4520171R	Fan Motor (910rpm)	1
6	4527203	Motor Support	1
7	464600001	Base Plate Painting Assy.	1
8	4527202	Partition Plate	1
9	455000506	Compressor Capacitor With Screw	1
10	453012700	Electric Panel	1
11	4524176	1/4 Liquid Valve(R410A)	1
12	4524595	1/2 Gas Valve for ONG R410A	1
13	455000001	single patch Capacitor for fan	1
14	4514588	5 Poles terminal block	1
15	204107	Cable clip Nylon	1
16	236179	2 Poles terminal block	1
17	4516637	Out sensor Black	1
18	463600000	Capillary Assy	1
19	469270002	Insulation Rub+Felt/Compress	1
20	463230014	Way Strainer	1
21	4510677	Nut With Flange M8 -D=24	3
22	4519987	Wire assy	1
23	460000000	Compressor Assy./ GMCC PA200X	1
24	433229	Valve Cover	1
26	4519606	Right side panel (painting plate)	1
27	461600001	4-Way Valve Assy.	1
28	4518952	4-W valve SHF-7H for R410A	1
29	4520071	4-W valve coil for R410A	1
30	433228	Back Side Net	1
31	4526298	Bridge	1
32	462300003	Condenser Assy.	1
33	4519614	Painting Top Cover	1
34	4519300	Nut M5 L	1
35	433225	Handle	1
36	4519607	Left Side Panel Painting Plate	1
37	470120001	Rubber Cushion /Base Plate	4
38	453121300	Install. Accessory	1

14.24 Outdoor Unit: ONG3-17 RC R22

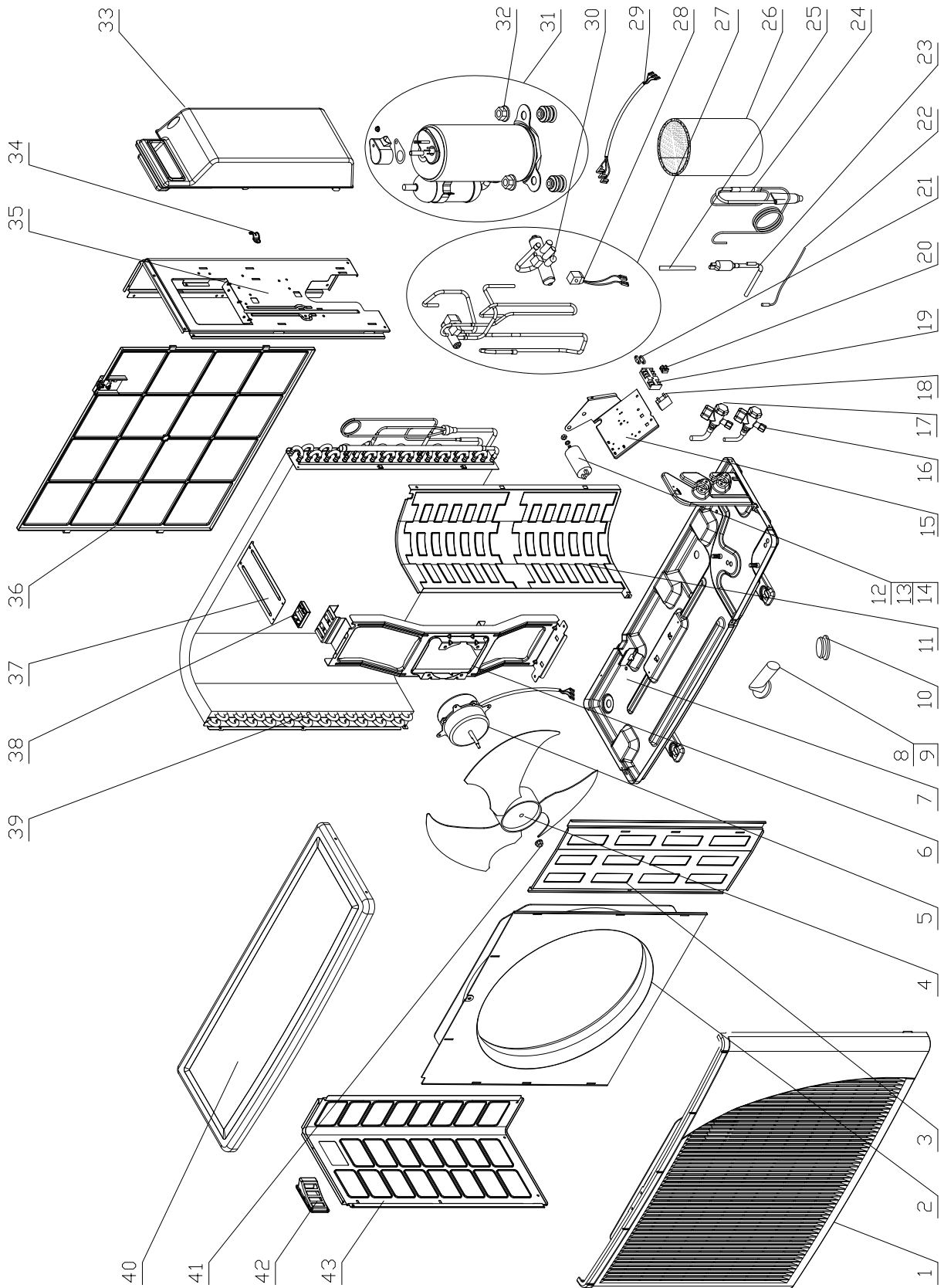

14.25 Outdoor Unit: ONG3-17 RC R22

No.	Item Code	Description	Quantity
1	433218	Front Panel A	1
2	433221	Air Inlet Ring-420	1
3	464860054	Painting Insulation Plate Assy/ONG	1
4	4519251	Axial Fan OD=400	1
5	4520171R	Fan Motor (910rpm)	1
6	4527203	Motor Support	1
7	4520060	Base Painting Assy.	1
8	255015	Washer	1
9	436632	Drain Connector	1
10	4519609	Drain Jam	1
11	433217	Partition Plate	1
12	455000507	Compressor Capacitor With Screw	1
13	203008	Washer	1
14	201019	Nut M8	1
15	453012700	Electric Panel	1
16	4519265	Liquid Valve OD=6.35	1
17	4519266	GAS VALVE OD=12.7	1
18	455000108	Double patch Capacitor for fan	1
19	4514588	5 Poles terminal block	1
20	236179	2 Poles terminal block	1
21	204107	Cable clip Nylon	1
22	4516637	Out sensor Black	1
24	4519898	Capillary Welding Assy.	1
25	4510463	Charge tube T2M ?6.35x0.7	1
26	452987500	Comp. Jacket	1
27	461600007	4-Way Valve Assy.	1
28	4514005	4-W valve coil	1
29	4519987	Wire assy	1
30	224136	4-W valve	1
31	460000002	CompressorAssy./PH330X2CS-4KT4	1
32	4510677	Nut With Flange M8 -D=24	3
33	433229	Valve Cover	1
34	452892900	Wire Clip	1
35	4519606	Right side panel (painting plate)	1
36	433228	Back Side Net	1
37	4526298	Bridge	1
38	452813200	coil stopper	1
39	4519620	Cond. ONG-14,18RC Not Assembly!	1
40	4519614	Painting Top Cover	1
41	4519300	Nut M5 L	1
42	433225	Handle	1
43	4519607	Left Side Panel Painting Plate	1

APPENDIX A

INSTALLATION AND OPERATION MANUAL

- ▶ INSTALLATION MANUAL PRIME SERIES
- ▶ OPERATION MANUAL PRIME SERIES
- ▶ OPERATION MANUAL RC3
- ▶ OPERATION MANUAL RC4