

Airwell

■ *Just feel well*

Mini Flow Logic-II

Design, Installation & Maintenance instruction

R410A HEAT PUMP 50HZ



Airwell
Residential

CONTENTS

1. General Information	03
2. Specification	04
3. Indoor model list	05
4. Refrigerant circuit	06
5. Dimensions	09
6. Wiring diagram	11
7. Capacity table	13
8. Performance curves	25
9. Outdoor installation	27
10. Electric installation	38
11. Trial operation and performance	47
12. Maintenance	58

1. General information

Airwell Flow Logic-II (Mini) adopts is a new generation products with DC inverter technology,high efficiency and energy saving,intelligent control,etc. All indoor units are with EEV to adjust the refrigerant flow, collect the data by the precise temperature.sensor. The indllors adopt the indoors of Flow Logic-II below 48000BTU/h. This system can realize max, 1 to 9.

Features:

1. High efficiency and energy saving
 - 1.1 Precise control, optimum operation
 - a. Simulate pressure control, to realize every indoor unit energy-saving and optimum operation.
 - b. Adopt inveter technology, adjust outdoor total load according to the actual request.
 - 1.2 Indoor individual control, economic running
 - 1.3 Advanced technology, high efficiency, and energy saving
 - a. High efficient scroll compressor
 - b. Precise control EEV
 - c. Excellent piping system design
 - d. Long distance of refrigerant piping
 - 1.4 Inverter operation, temperature sensor technology, reduce power consumption
2. Beautiful and comfortable
 - a. Compact outdoor appearance design
 - b. Perfect cooling and heating, more comfortable
 - c. Super slim design, fit for the decor
3. Healthy and environment friendly
 - a. Adopt environment friendly refrigerant R410a, protect ozone layer against the earth being warmed up
 - b. Intelligent healthy module for removing formaldehyde, easily resolve the decoration pollution
 - c. Strong ultraviolet radiation to kill the bacteria, make indoor air more healthy
4. More convenient
 - a. Flexible control indoors
One outdoor can control multiple indoors at the same time
 - b. Multiple indoor control types
Infrared control, wired control, infrared control + wired control, central control
 - c. Free combination
Due to the different space, select indoor type freely
 - d. Multiple air sending, air return types
5. Easy installation
Super long piping system, free installation

2. Specification









Equivalent HP	3	7	
Model	AWAU-YCV080-H11	AWAU-YCV180-H13	
Nominal cooling capacity(KW)	8.0	18	
Nominal heating capacity(KW)	9.5	20	
Heating capacity at low temp.(KW)	9.0	18.3	
Power source	1PH~, 220V, 50Hz	3N~, 380V, 50Hz	
IP level	IP24	IP24	
Electrical characteristics	Operating/Max. current(A)	11.0/12.0	14.2/17.0
	Operating/Max. consumption(kw)	2.2/3.4	5.5/10.3
	Operating/Max. current(A)	11.4/16.0	15.1/18.4
	Operating/Max. consumption(kw)	2.15/3.4	5.25/11.3
	Power consumption when heating at low temp.(kw)	2.52	5.9
	Output power of outdoor motor(KW)	0.06*1	0.13*2
Exterior dimensions (mm)	948*340*830	948*340*1250	
Weight (Kg)	74/89	120/130	
Exterior colour	ivory white	ivory white	
Compressor type	rotary	scroll	
Compressor model	TNB220FLBM1	ANB42FCHMT	
Oil charge(l)	0.67	1.7	
Oil model	MEL56	FV50S	
Outdoor motor rate(rpm)	840/780/550	920/840/550	
Outdoor airflow (m³/h)	3500	6500	
Refrigerant (R410A) charge (Kg)	2.4	5.0	
Gas piping(mm)	∅ 15.88	∅ 19.05	
Liquid piping(mm)	∅ 9.52	∅ 9.52	
Noise level(dB(A))	55	60	
Max. indoor units	5	9	

Norminal condition: indoor temperature (cooling): 27°CDB/19°CWB, indoor temperature (heating): 20°CDB/14.5°CWB

Outdoor temperature(cooling): 35°CDB/24°CWB, outdoor temperature(heating): 7°CDB/6°CWB

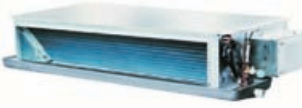
The noise level will be measured in the third octave band limited values in the semi-anechoic chamber, using a Real Time Analyser calibrated sound intensity meter. It is a sound pressure noise level.

3. Indoor model list:

Indoor	<p>4-WAY CASSETTE TYPE / Panel 60x60</p> <p>AWSI-CBV009-N11 AWSI-CBV012-N11 AWSI-CBV016-N11</p> 	
	<p>4-WAY CASSETTE TYPE / Panel 90x90</p> <p>AWSI-CCV024-N11</p>  <p>AWSI-CCV030-N11 AWSI-CCV048-N11</p> 	<p>CONVERTIBLE TYPE</p> <p>AWSI-FAV012-N11 AWSI-FAV024-N11</p> 
	<p>LOW ESP DUCT TYPE</p> <p>AWSI-DAV009-N11</p> 	<p>MED ESP DUCT TYPE</p> <p>AWSI-DBV018-N11 AWSI-DBV028-N11</p>  <p>AWSI-DBV038-N11</p> 
	<p>WALL MOUNTED TYPE</p> <p>AWSI-HAV007-N11 AWSI-HAV009-N11 AWSI-HAV012-N11 AWSI-HAV018-N11</p> 	
	<p>CONSOLE TYPE</p> <p>AWSI-EAV012-N11</p> 	

The information for indoors please refer to the manual of Flow Logic.

4. Refrigerant circuit

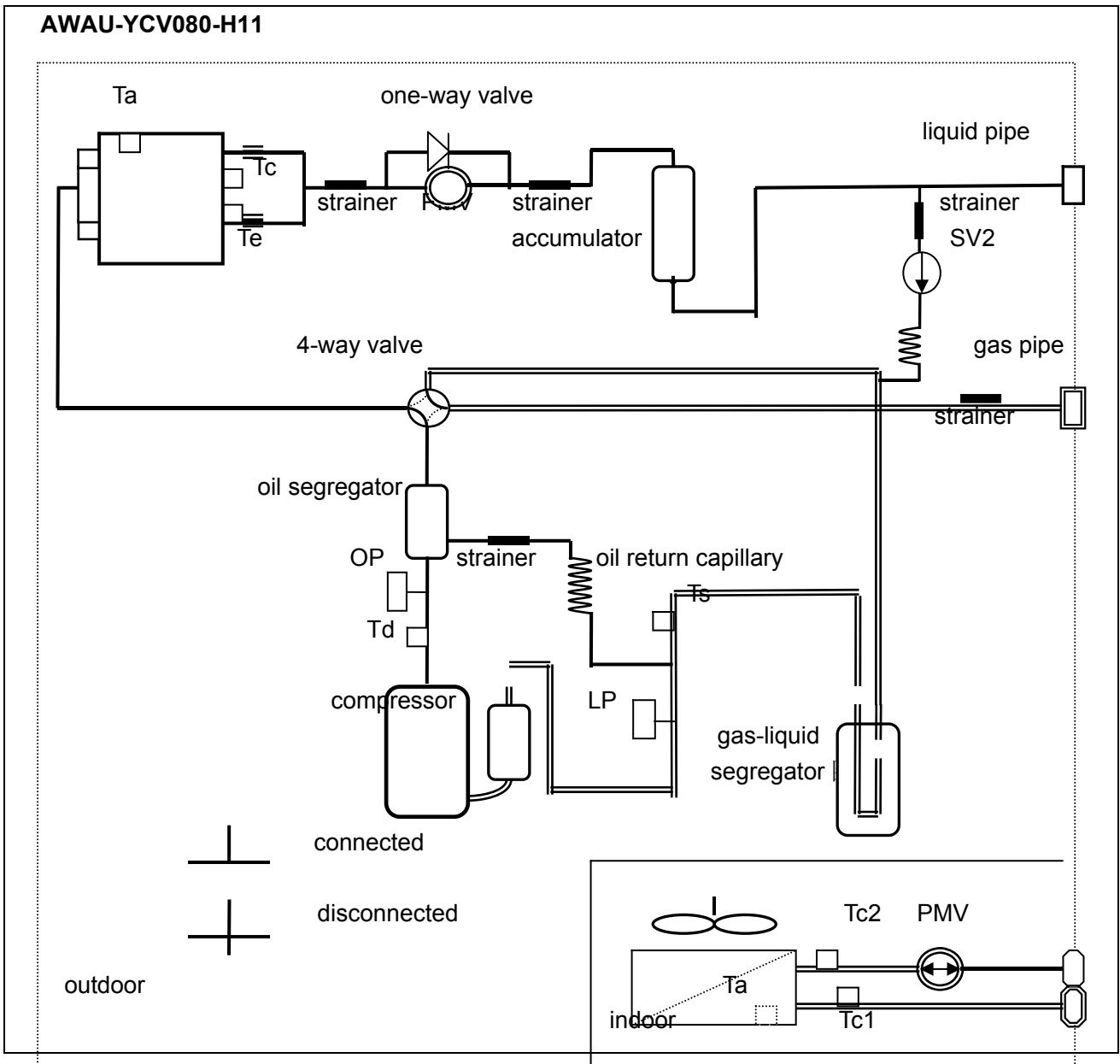

AWAU-YCV180-H13

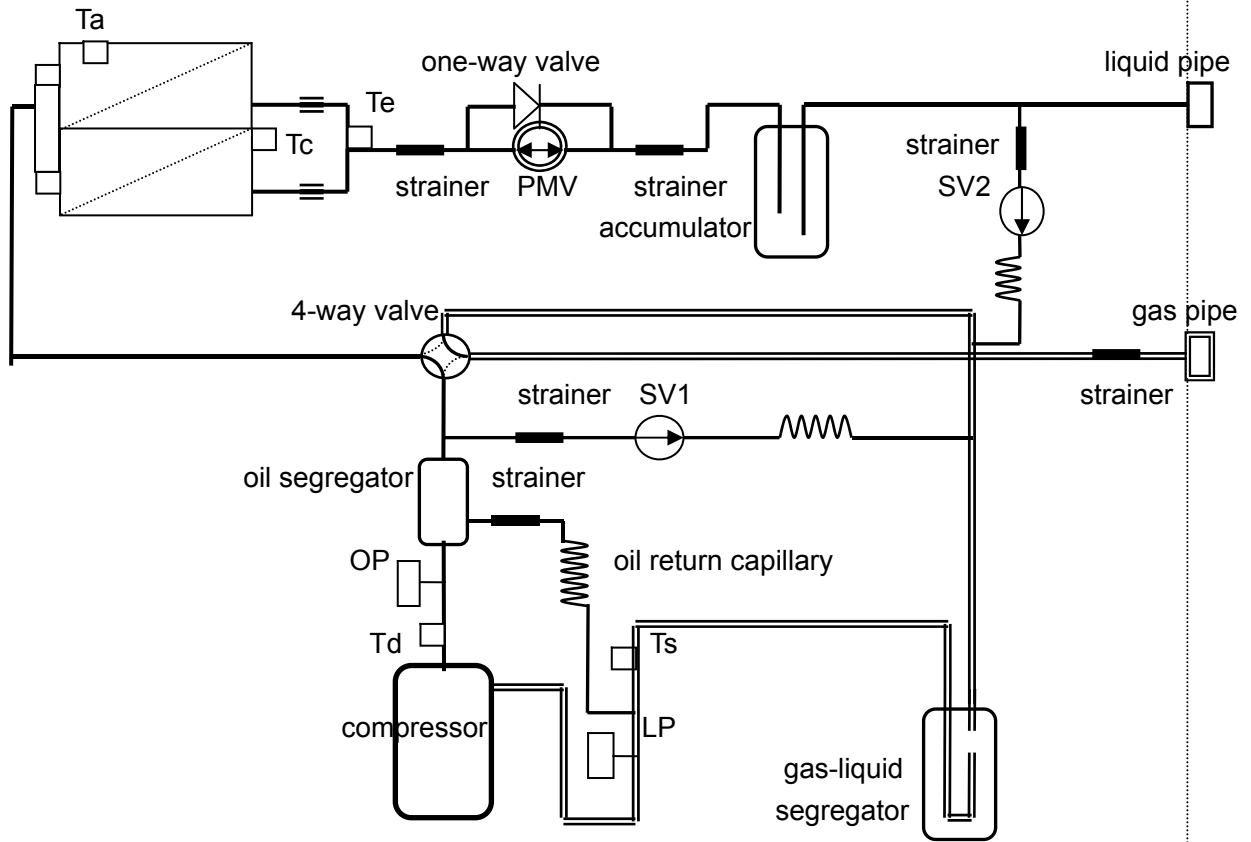

legend

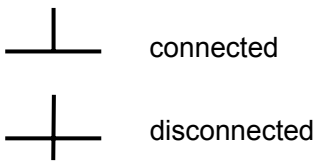

outdoor

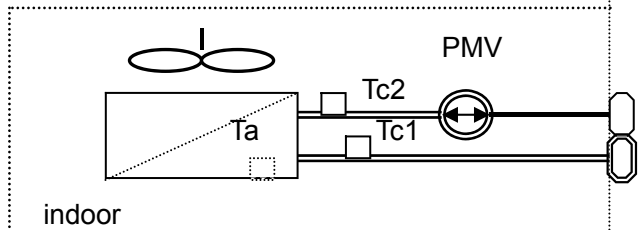

Part name	Sign	Function	Data
Compressor		capacity control, meet indoor load request by adjusting the frequency	resistor of 3-phase coil:0.302 Ω (20℃)
Pressure switch	HP	High pressure protection	4.15Mpa, OFF
	LP	Low pressure protection	0.05 Mpa,OFF
Electronic expansion valve	PMV	in heating,refrigerant flow control	10TON
Solenoid valve	SV1	1. keep balance of high/low pressure when compressor starts up or stops; 2. high/low pressure protection	AC220V, open when power is on; close when power is off
	SV2	refrigerant jet protection when discharging temp. is too high	
4-way valve	4WV	change over between cooling and heating	AC220V,electrified in heating; not electrified in cooling or defrosting
Temp. sensor	Te	check frost condition of outdoor heat exchanger	R(25℃)=10K B(25/50℃)=3741K
	Ts	detect the suction temp. of compressor	
	Tc	check the temp. of main pipe of condenser gas pipe, control PMV1 in heating	
	Ta	detect ambient temp.,set primary setting for fan speed, target pressure and EEV open angle	
	Td	detect the discharging temp. of compressor	R(80℃)=50K B(25/80℃)=4450K
Heater	HEATER	used to heat oil in compressor	40W, 220V

5. Dimensions

AWAU-YCV080-H11

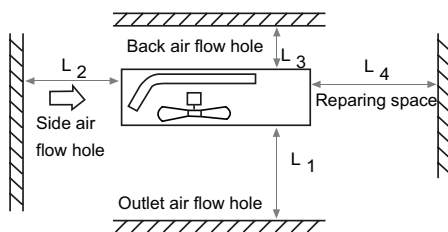
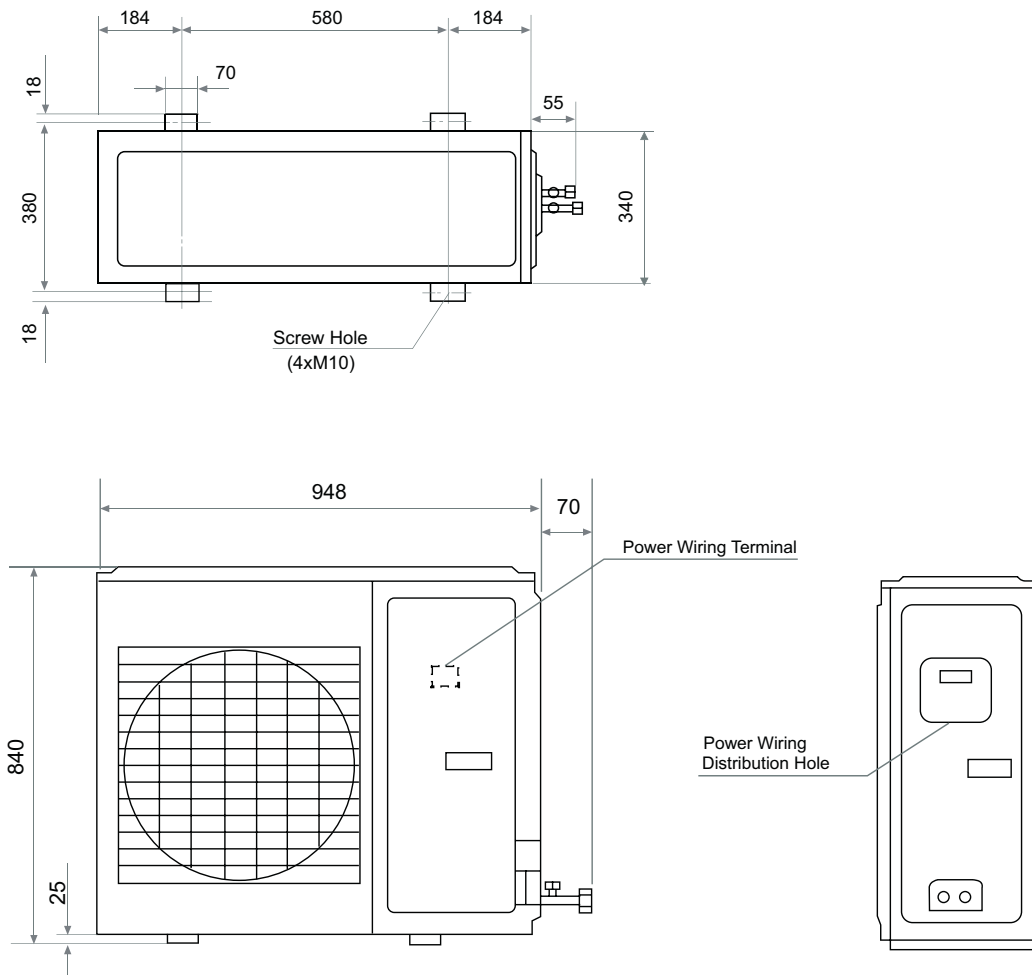

Note:

- (1) Fix the parts with screws
- (2) Don't intake the strong wind directly to the outlet air-flow hole.
- (3) A one meter distance should be kept from the unit top
- (4) Don't block the surroundings of the unit with sundries.

Installation servicing space (at least)		Unit:mm		
Dimension	Installation	I	II	III
L ₁	Leace space	Leace space	Leace space	500
L ₂		300	0	Leace space
L ₃		100	150	100
L ₄		0	0	0

AWAU-YCV180-H13

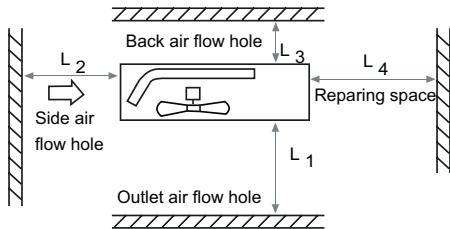
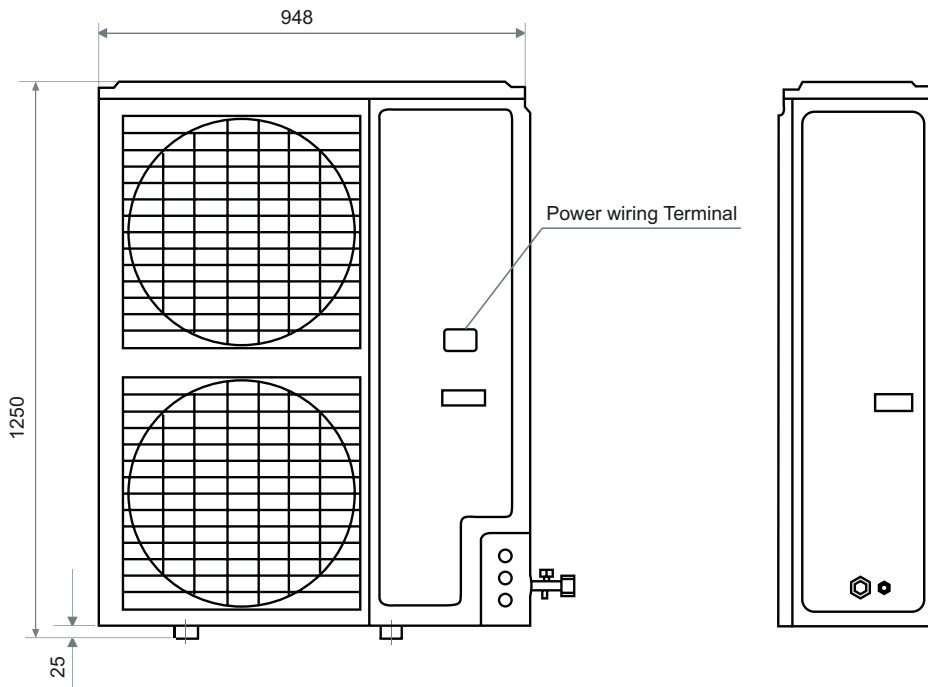
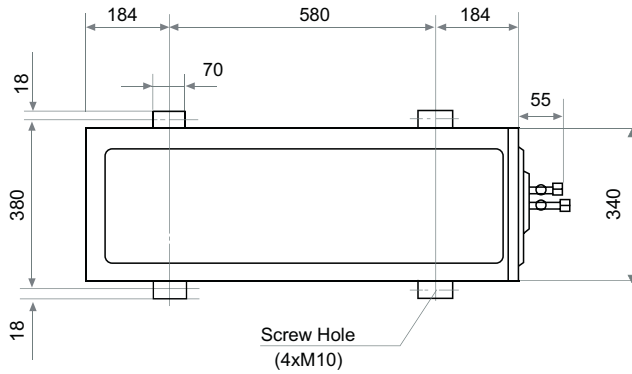

Note:

- (1) Fix the parts with screws
- (2) Don't intake the strong wind directly to the outlet air-flow hole.
- (3) A one meter distance should be kept from the unit top
- (4) Don't block the surroundings of the unit with sundries.

Installation servicing space (at least)			Unit:mm
Installation Dimension	I	II	III
L ₁		Leace space	500
L ₂	300	0	
L ₃	100	150	100
L ₄	0	0	0

6. Wiring diagram AWAU-YCV080-H11

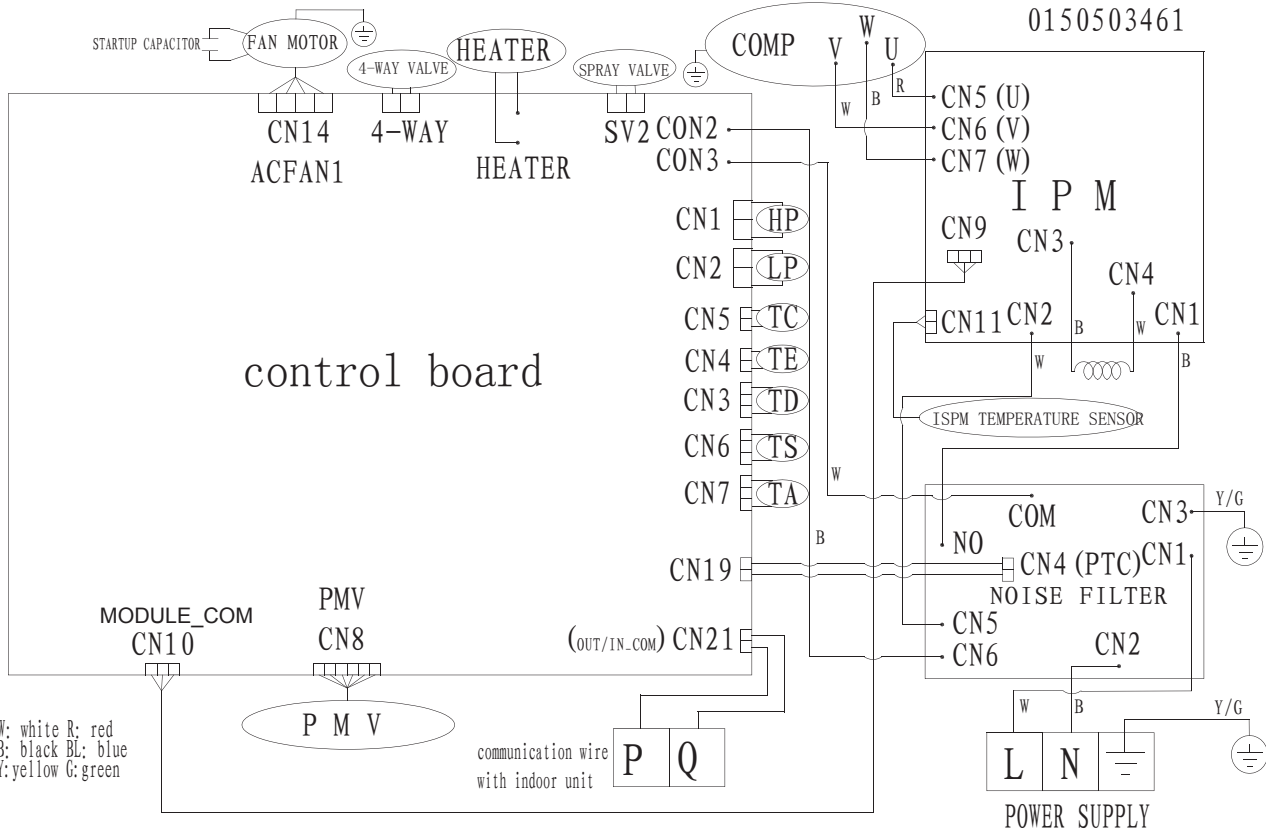

AWAU-YCV080-H13:

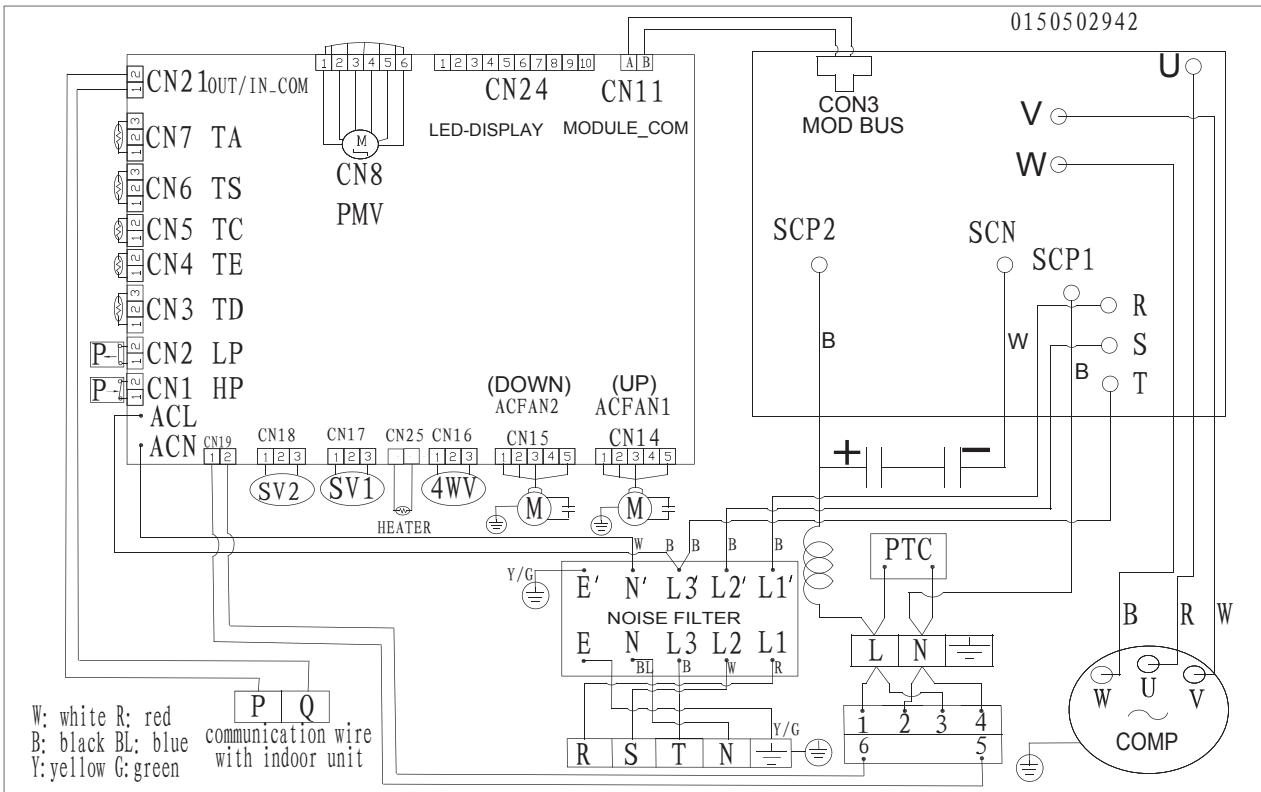

AWAU-YCV180-H13:

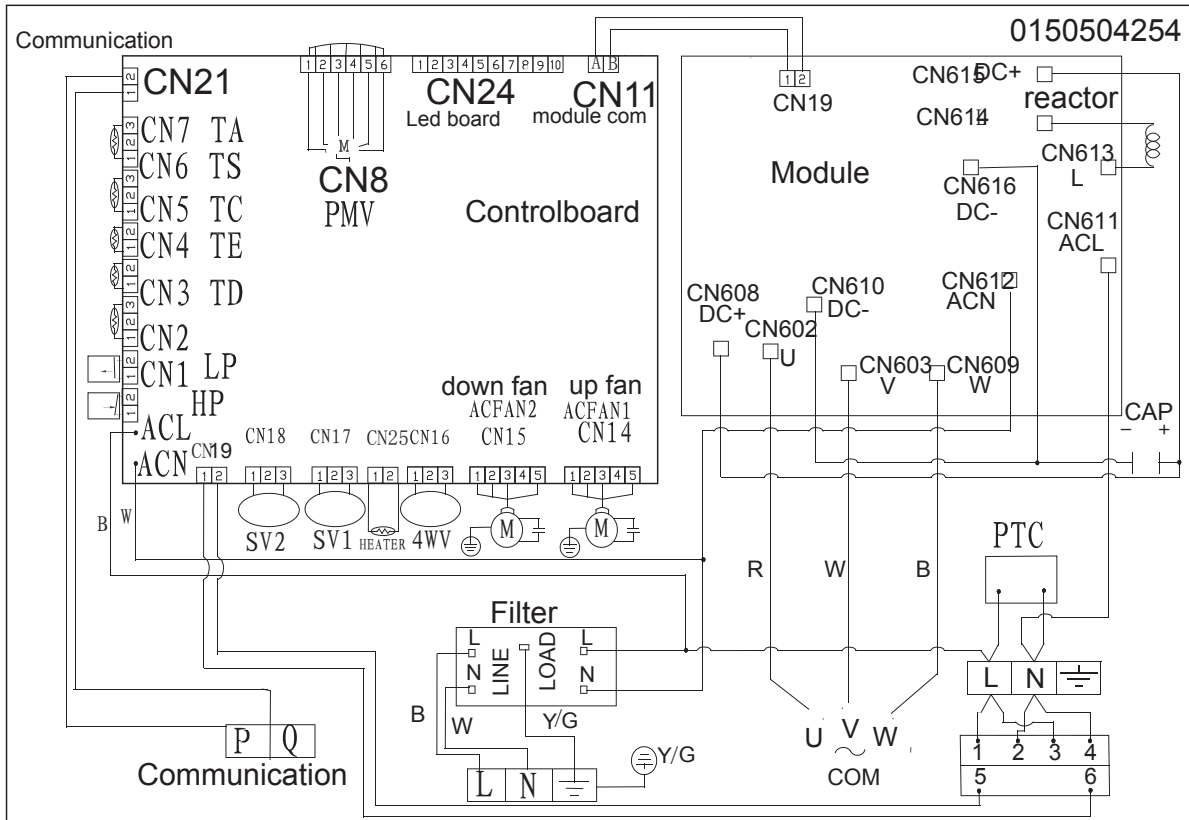

7. Capacity table

AWAU-YCV080-H11 cooling mode

capacity factor	outdoor temp. (°CDB)	indoor temp. (°CWB)													
		14(°C)		16(°C)		18(°C)		19(°C)		20(°C)		22(°C)		24(°C)	
		TC	PI	TC	PI	TC	PI	TC	PI	TC	PI	TC	PI	TC	PI
		KW	KW	KW	KW	KW	KW	KW	KW	KW	KW	KW	KW	KW	KW
130%	5	7.2	0.99	8.5	1.19	9.84	1.40	10.51	1.57	10.9	1.53	11.3	1.40	11.4	1.27
	10	7.2	1.04	8.5	1.25	9.84	1.46	10.51	1.61	10.6	1.54	10.9	1.47	11.1	1.41
	15	7.2	1.09	8.5	1.30	9.84	1.53	10.16	1.69	10.3	1.55	10.5	1.55	10.8	1.56
	20	7.2	1.14	8.5	1.45	9.73	1.75	9.84	1.76	9.9	1.77	10.2	1.78	10.4	1.80
	25	7.2	1.37	8.5	1.74	9.38	1.97	9.49	1.98	9.6	1.99	9.9	2.01	10.1	2.03
	30	7.2	1.61	8.5	2.07	9.06	2.21	9.17	2.21	9.3	2.22	9.5	2.23	9.8	2.31
	35	7.2	1.91	8.5	2.41	8.74	2.43	8.85	2.44	9.0	2.46	9.2	2.48	9.5	2.51
	41	7.2	2.18	8.2	2.60	8.42	2.62	8.53	2.64	8.7	2.65	8.9	2.71	9.2	2.74
	43	7.2	2.36	8.0	2.74	8.21	2.98	8.35	3.04	8.5	3.07	8.7	3.12	9.0	3.16
120%	5	6.7	0.92	7.9	1.09	9.10	1.22	9.66	1.37	10.4	1.48	11.0	1.50	11.2	1.39
	10	6.7	0.95	7.9	1.14	9.10	1.34	9.66	1.44	10.3	1.53	10.7	1.52	10.9	1.46
	15	6.7	0.99	7.9	1.19	9.10	1.40	9.66	1.50	10.2	1.57	10.4	1.55	10.6	1.53
	20	6.7	1.04	7.9	1.29	9.10	1.58	9.66	1.74	9.8	1.75	10.0	1.77	10.2	1.78
	25	6.7	1.22	7.9	1.55	9.10	1.90	9.35	1.97	9.5	1.98	9.7	2.00	9.9	2.02
	30	6.7	1.42	7.9	1.83	8.88	2.19	9.03	2.20	9.2	2.21	9.3	2.23	9.6	2.25
	35	6.7	1.71	7.9	2.16	8.57	2.42	8.71	2.43	8.8	2.44	9.0	2.46	9.2	2.49
	41	6.7	1.97	7.9	2.54	8.25	2.60	8.35	2.60	8.5	2.60	8.7	2.71	8.9	2.71
	43	6.7	2.11	7.9	2.90	8.07	2.93	8.18	2.98	8.3	3.01	8.5	3.09	8.7	3.15
110%	5	6.1	0.82	7.2	0.99	8.32	1.16	8.85	1.25	9.4	1.33	10.8	1.58	11.1	1.49
	10	6.1	0.86	7.2	1.03	8.32	1.21	8.85	1.30	9.4	1.39	10.5	1.57	10.7	1.52
	15	6.1	0.90	7.2	1.08	8.32	1.27	8.85	1.36	9.4	1.46	10.2	1.56	10.4	1.54
	20	6.1	0.94	7.2	1.14	8.32	1.39	8.85	1.53	9.4	1.67	9.8	1.76	10.1	1.77
	25	6.1	1.09	7.2	1.36	8.32	1.67	8.85	1.97	9.2	2.06	9.4	2.08	9.6	2.09
	30	6.1	1.29	7.2	1.62	8.32	1.99	8.85	2.17	8.9	2.20	9.2	2.21	9.4	2.23
	35	6.1	1.52	7.2	1.91	8.32	2.35	8.53	2.41	8.6	2.43	8.8	2.44	9.1	2.47
	41	6.1	1.77	7.2	2.24	8.07	2.63	8.21	2.64	8.3	2.63	8.5	2.68	8.7	2.74
	43	6.1	1.91	7.2	2.38	7.86	2.76	8.04	2.87	8.1	2.76	8.3	2.82	8.5	2.87
100%	5	5.6	0.77	6.6	0.89	7.54	1.05	8.00	1.12	8.6	1.19	9.6	1.35	10.9	1.58
	10	5.6	0.77	6.6	0.93	7.54	1.09	8.00	1.17	8.6	1.25	9.6	1.42	10.5	1.57
	15	5.6	0.81	6.6	0.97	7.54	1.14	8.00	1.22	8.6	1.31	9.6	1.48	10.2	1.56
	20	5.6	0.84	6.6	1.02	7.54	1.21	8.00	1.33	8.6	1.45	9.6	1.71	9.8	1.76
	25	5.6	0.95	6.6	1.19	7.54	1.46	8.00	1.60	8.6	1.74	9.3	1.97	9.5	1.99
	30	5.6	1.13	6.6	1.42	7.54	1.73	8.00	1.90	8.6	2.06	9.0	2.20	9.2	2.22
	35	5.6	1.33	6.6	1.67	7.54	2.04	8.00	2.20	8.5	2.41	8.7	2.43	8.8	2.45
	41	5.6	1.56	6.6	1.94	7.54	2.39	8.00	2.52	8.2	2.64	8.4	2.65	8.5	2.68
	43	5.6	1.70	6.6	2.08	7.54	2.53	8.00	2.76	8.0	2.76	8.2	2.79	8.4	2.82
90%	5	5.0	0.65	5.9	0.79	6.83	0.93	7.26	0.99	7.7	1.06	8.6	1.20	9.5	1.34
	10	5.0	0.69	5.9	0.83	6.83	0.97	7.26	1.04	7.7	1.11	8.6	1.26	9.5	1.41
	15	5.0	0.72	5.9	0.86	6.83	1.01	7.26	1.09	7.7	1.16	8.6	1.31	9.5	1.47
	20	5.0	0.75	5.9	0.90	6.83	1.06	7.26	1.14	7.7	1.25	8.6	1.46	9.5	1.69
	25	5.0	0.83	5.9	1.03	6.83	1.25	7.26	1.37	7.7	1.50	8.6	1.76	9.3	1.97
	30	5.0	0.98	5.9	1.23	6.83	1.49	7.26	1.63	7.7	1.78	8.6	2.10	9.0	2.19
	35	5.0	1.16	5.9	1.44	6.83	1.75	7.26	1.92	7.7	2.10	8.5	2.41	8.7	2.43
	41	5.0	1.35	5.9	1.69	6.83	2.06	7.26	2.12	7.7	2.45	8.2	2.63	8.3	2.65
	43	5.0	1.49	5.9	1.78	6.83	2.19	7.26	2.35	7.7	2.65	8.0	2.74	8.1	2.79
80%	5	4.4	0.70	5.2	0.70	6.05	0.81	6.48	0.87	6.8	0.93	7.6	1.05	8.5	1.17
	10	4.4	0.73	5.2	0.73	6.05	0.85	6.48	0.91	6.8	0.97	7.6	1.10	8.5	1.23
	15	4.4	0.76	5.2	0.76	6.05	0.89	6.48	0.95	6.8	1.02	7.6	1.15	8.5	1.29
	20	4.4	0.80	5.2	0.79	6.05	0.93	6.48	1.00	6.8	1.07	7.6	1.23	8.5	1.48
	25	4.4	0.89	5.2	0.88	6.05	1.07	6.48	1.00	6.8	1.27	7.6	1.48	8.5	1.83
	30	4.4	1.06	5.2	1.05	6.05	1.27	6.48	1.16	6.8	1.50	7.6	1.76	8.5	2.03
	35	4.4	1.24	5.2	1.23	6.05	1.49	6.48	1.63	6.8	1.77	7.6	2.07	8.5	2.40
	41	4.4	1.45	5.2	1.44	6.05	1.74	6.48	1.90	6.8	2.08	7.6	2.43	8.1	2.63
	43	4.4	1.60	5.2	1.56	6.05	1.84	6.48	2.07	6.8	2.29	7.6	2.51	7.7	2.79
70%	5	3.9	0.70	4.6	0.69	5.27	0.70	5.63	0.75	6.0	0.80	6.7	0.91	7.4	0.74
	10	3.9	0.72	4.6	0.72	5.27	0.73	5.63	0.78	6.0	0.84	6.7	0.95	7.4	1.06
	15	3.9	0.76	4.6	0.75	5.27	0.76	5.63	0.82	6.0	0.87	6.7	0.99	7.4	1.11

AWAU-YCV080-H11 cooling mode

capacity factor	outdoor temp. (°CDB)	indoor temp. (°CWB)													
		14(°C)		16(°C)		18(°C)		19(°C)		20(°C)		22(°C)		24(°C)	
		TC	PI	TC	PI	TC	PI	TC	PI	TC	PI	TC	PI	TC	PI
		KW	KW	KW	KW	KW	KW	KW	KW	KW	KW	KW	KW	KW	KW
70%	20	3.9	0.79	4.6	0.79	5.27	0.80	5.63	0.86	6.0	0.92	6.7	1.04	7.4	1.17
	25	3.9	0.89	4.6	0.83	5.27	0.89	5.63	0.97	6.0	1.05	6.7	1.23	7.4	1.41
	30	3.9	1.10	4.6	1.10	5.27	1.06	5.63	1.15	6.0	1.25	6.7	1.45	7.4	1.67
	35	3.9	1.24	4.6	1.24	5.27	1.24	5.63	1.36	6.0	1.47	6.7	1.71	7.4	1.97
	41	3.9	1.45	4.6	1.45	5.27	1.45	5.63	1.56	6.0	1.72	6.7	2.00	7.4	2.31
	43	3.9	1.57	4.6	1.55	5.27	1.60	5.63	1.60	6.0	1.85	6.7	2.18	7.4	2.52
60%	5	3.3	0.69	3.9	0.70	4.53	0.71	4.85	0.64	5.2	0.68	5.7	0.76	6.3	0.85
	10	3.3	0.72	3.9	0.73	4.53	0.74	4.85	0.66	5.2	0.71	5.7	0.80	6.3	0.89
	15	3.3	0.75	3.9	0.76	4.53	0.77	4.85	0.69	5.2	0.74	5.7	0.83	6.3	0.93
	20	3.3	0.79	3.9	0.80	4.53	0.77	4.85	0.72	5.2	0.77	5.7	0.87	6.3	0.98
	25	3.3	0.83	3.9	0.89	4.53	0.86	4.85	0.79	5.2	0.86	5.7	0.99	6.3	1.14
	30	3.3	1.10	3.9	1.05	4.53	1.02	4.85	0.94	5.2	1.02	5.7	1.18	6.3	1.35
	35	3.3	1.24	3.9	1.24	4.53	1.20	4.85	1.11	5.2	1.20	5.7	1.38	6.3	1.59
	41	3.3	1.45	3.9	1.44	4.53	1.39	4.85	1.29	5.2	1.39	5.7	1.62	6.3	1.86
43	3.3	1.55	3.9	1.57	4.53	1.52	4.85	1.43	5.2	1.52	5.7	1.73	6.3	2.02	
50%	5	2.8	0.64	3.3	0.70	3.79	0.70	4.04	0.70	4.3	0.71	4.8	0.70	5.3	0.76
	10	2.8	0.66	3.3	0.72	3.79	0.73	4.04	0.73	4.3	0.74	4.8	0.73	5.3	0.80
	15	2.8	0.69	3.3	0.76	3.79	0.76	4.04	0.76	4.3	0.77	4.8	0.76	5.3	0.83
	20	2.8	0.72	3.3	0.79	3.79	0.80	4.04	0.80	4.3	0.77	4.8	0.80	5.3	0.87
	25	2.8	0.79	3.3	0.89	3.79	0.89	4.04	0.89	4.3	0.86	4.8	0.89	5.3	0.99
	30	2.8	0.94	3.3	1.10	3.79	1.05	4.04	1.05	4.3	1.02	4.8	1.05	5.3	1.18
	35	2.8	1.11	3.3	1.24	3.79	1.24	4.04	1.24	4.3	1.20	4.8	1.24	5.3	1.38
	41	2.8	1.29	3.3	1.45	3.79	1.44	4.04	1.44	4.3	1.39	4.8	1.44	5.3	1.62
43	2.8	1.43	3.3	1.57	3.79	1.57	4.04	1.57	4.3	1.52	4.8	1.57	5.3	1.73	

AWAU-YCV180-H13 cooling mode

capacity factor	outdoor temp. (°CDB)	indoor temp. (°CWB)													
		14(°C)		16(°C)		18(°C)		19(°C)		20(°C)		22(°C)		24(°C)	
		TC	PI	TC	PI	TC	PI	TC	PI	TC	PI	TC	PI	TC	PI
		KW	KW	KW	KW	KW	KW	KW	KW	KW	KW	KW	KW	KW	KW
130%	5	16.3	2.47	19.2	2.98	22.14	3.49	23.65	3.93	24.6	3.84	25.3	3.50	25.7	3.16
	10	16.3	2.59	19.2	3.12	22.14	3.66	23.65	3.93	23.9	3.86	24.5	3.69	25.0	3.51
	15	16.3	2.72	19.2	3.26	22.14	3.82	22.86	3.92	23.2	3.88	23.7	3.87	24.3	3.89
	20	16.3	2.85	19.2	3.62	21.90	4.37	22.14	4.39	22.4	4.41	22.9	4.46	23.5	4.50
	25	16.3	3.42	19.2	4.34	21.11	4.94	21.35	4.96	21.7	4.98	22.2	5.03	22.8	5.08
	30	16.3	4.03	19.2	5.16	20.39	5.53	20.63	5.53	20.9	5.54	21.4	5.58	22.1	5.78
	35	16.3	4.79	19.1	6.02	19.67	6.08	19.91	6.11	20.2	6.15	20.7	6.21	21.3	6.27
	41	16.3	5.45	18.4	6.49	18.96	6.55	19.19	6.59	19.5	6.63	20.0	6.77	20.6	6.84
	43	16.3	5.91	18.0	6.84	18.48	7.03	18.80	7.16	19.1	7.27	19.6	7.28	20.2	7.30
120%	5	15.0	2.31	17.7	2.72	20.47	3.04	21.74	3.42	23.4	3.71	24.8	3.75	25.2	3.49
	10	15.0	2.37	17.7	2.85	20.47	3.34	21.74	3.59	23.1	3.84	24.1	3.81	24.5	3.65
	15	15.0	2.48	17.7	2.98	20.47	3.51	21.74	3.75	22.9	3.93	23.3	3.86	23.8	3.82
	20	15.0	2.59	17.7	3.22	20.47	3.96	21.74	4.35	22.1	4.39	22.5	4.42	23.0	4.46
	25	15.0	3.06	17.7	3.86	20.47	4.75	21.03	4.93	21.3	4.95	21.8	5.00	22.3	5.04
	30	15.0	3.56	17.7	4.59	19.99	5.47	20.31	5.50	20.6	5.53	21.0	5.58	21.5	5.63
	35	15.0	4.28	17.7	5.41	19.27	6.04	19.59	6.07	19.8	6.11	20.3	6.16	20.8	6.22
	41	15.0	4.93	17.7	6.34	18.56	6.49	18.80	6.50	19.1	6.50	19.6	6.77	20.1	6.77
	43	15.0	5.28	17.7	7.09	18.16	7.11	18.40	7.15	18.6	7.21	19.1	7.23	19.7	7.27
110%	5	13.8	2.05	16.3	2.47	18.72	2.89	19.91	3.13	21.2	3.33	24.4	3.95	24.9	3.73
	10	13.8	2.15	16.3	2.59	18.72	3.03	19.91	3.26	21.2	3.49	23.7	3.93	24.1	3.80
	15	13.8	2.24	16.3	2.70	18.72	3.17	19.91	3.39	21.2	3.64	22.9	3.91	23.3	3.86
	20	13.8	2.35	16.3	2.84	18.72	3.49	19.91	3.82	21.2	4.18	22.1	4.39	22.6	4.43
	25	13.8	2.72	16.3	3.41	18.72	4.18	19.91	4.93	20.6	5.15	21.1	5.19	21.6	5.23
	30	13.8	3.22	16.3	4.05	18.72	4.97	19.91	5.42	20.1	5.49	20.6	5.53	21.1	5.58
	35	13.8	3.79	16.3	4.77	18.72	5.86	19.19	6.04	19.4	6.06	19.9	6.11	20.4	6.17
	41	13.8	4.43	16.3	5.60	18.16	6.58	18.48	6.61	18.7	6.57	19.1	6.70	19.7	6.84
	43	13.8	4.78	16.3	5.95	17.68	6.91	18.08	7.18	18.3	6.91	18.7	7.05	19.2	7.18
100%	5	12.5	1.92	14.8	2.22	16.96	2.63	18.00	2.80	19.3	2.98	21.5	3.38	24.5	3.95
	10	12.5	1.93	14.8	2.32	16.96	2.72	18.00	2.93	19.3	3.13	21.5	3.54	23.7	3.93
	15	12.5	2.01	14.8	2.43	16.96	2.85	18.00	3.06	19.3	3.27	21.5	3.71	22.9	3.91
	20	12.5	2.11	14.8	2.54	16.96	3.03	18.00	3.33	19.3	3.63	21.5	4.28	22.1	4.39
	25	12.5	2.39	14.8	2.98	16.96	3.64	18.00	3.99	19.3	4.36	21.0	4.92	21.4	4.96
	30	12.5	2.82	14.8	3.54	16.96	4.32	18.00	4.74	19.3	5.15	20.2	5.49	20.6	5.54
	35	12.5	3.33	14.8	4.17	16.96	5.10	18.00	5.50	19.1	6.02	19.5	6.07	19.9	6.12
	41	12.5	3.89	14.8	4.85	16.96	5.97	18.00	6.29	18.4	6.59	18.8	6.63	19.2	6.70
	43	12.5	4.24	14.8	5.20	16.96	6.32	18.00	6.91	17.9	6.91	18.4	6.98	18.8	7.05
90%	5	11.3	1.64	13.3	1.97	15.37	2.32	16.33	2.48	17.4	2.65	19.4	3.01	21.3	3.36
	10	11.3	1.72	13.3	2.06	15.37	2.42	16.33	2.60	17.4	2.78	19.4	3.15	21.3	3.52
	15	11.3	1.80	13.3	2.15	15.37	2.52	16.33	2.72	17.4	2.91	19.4	3.29	21.3	3.68
	20	11.3	1.88	13.3	2.26	15.37	2.65	16.33	2.86	17.4	3.11	19.4	3.66	21.3	4.24
	25	11.3	2.08	13.3	2.59	15.37	3.14	16.33	3.43	17.4	3.74	19.4	4.39	20.9	4.92
	30	11.3	2.46	13.3	3.07	15.37	3.73	16.33	4.08	17.4	4.44	19.4	5.25	20.2	5.49
	35	11.3	2.89	13.3	3.60	15.37	4.39	16.33	4.81	17.4	5.24	19.1	6.02	19.5	6.06
	41	11.3	3.38	13.3	4.21	15.37	5.14	16.33	5.29	17.4	6.13	18.4	6.59	18.6	6.63
	43	11.3	3.73	13.3	4.46	15.37	5.48	16.33	5.88	17.4	6.63	17.9	6.84	18.2	6.98
80%	5	10.0	1.46	11.8	1.74	13.62	2.02	14.58	2.17	15.4	2.32	17.2	2.63	19.0	2.94
	10	10.0	1.52	11.8	1.82	13.62	2.12	14.58	2.28	15.4	2.43	17.2	2.76	19.0	3.08
	15	10.0	1.58	11.8	1.89	13.62	2.21	14.58	2.38	15.4	2.54	17.2	2.88	19.0	3.22
	20	10.0	1.66	11.8	1.98	13.62	2.32	14.58	2.49	15.4	2.67	17.2	3.08	19.0	3.70
	25	10.0	1.79	11.8	2.21	13.62	2.67	14.58	2.91	15.4	3.16	17.2	3.70	19.0	4.59
	30	10.0	2.12	11.8	2.62	13.62	3.16	14.58	3.46	15.4	3.75	17.2	4.39	19.0	5.08
	35	10.0	2.49	11.8	3.08	13.62	3.73	14.58	4.07	15.4	4.43	17.2	5.18	19.0	5.99
	41	10.0	2.97	11.8	3.59	13.62	4.35	14.58	4.76	15.4	5.20	17.2	6.06	18.2	6.58
	43	10.0	3.42	11.8	3.90	13.62	4.61	14.58	5.17	15.4	5.71	17.2	6.26	17.3	6.98

AWAU-YCV180-H13 cooling mode

capacity factor	outdoor temp. (°CDB)	indoor temp. (°CWB)													
		14(°C)		16(°C)		18(°C)		19(°C)		20(°C)		22(°C)		24(°C)	
		TC	PI	TC	PI	TC	PI	TC	PI	TC	PI	TC	PI	TC	PI
		KW	KW	KW	KW	KW	KW	KW	KW	KW	KW	KW	KW	KW	KW
70%	5	8.8	1.27	10.4	1.50	11.87	1.75	12.66	1.87	13.5	2.01	15.1	2.27	16.6	1.85
	10	8.8	1.32	10.4	1.57	11.87	1.83	12.66	1.96	13.5	2.10	15.1	2.37	16.6	2.65
	15	8.8	1.38	10.4	1.64	11.87	1.91	12.66	2.05	13.5	2.19	15.1	2.48	16.6	2.77
	20	8.8	1.44	10.4	1.71	11.87	2.00	12.66	2.15	13.5	2.30	15.1	2.60	16.6	2.94
	25	8.8	1.51	10.4	1.86	11.87	2.23	12.66	2.43	13.5	2.63	15.1	3.07	16.6	3.52
	30	8.8	1.79	10.4	2.20	11.87	2.65	12.66	2.88	13.5	3.12	15.1	3.64	16.6	4.18
	35	8.8	2.11	10.4	2.59	11.87	3.11	12.66	3.39	13.5	3.67	15.1	4.28	16.6	4.93
	41	8.8	2.45	10.4	2.98	11.87	3.63	12.66	3.89	13.5	4.29	15.1	5.01	16.6	5.78
43	8.8	2.59	10.4	3.12	11.87	4.01	12.66	3.99	13.5	4.62	15.1	5.44	16.6	6.29	
60%	5	7.5	1.08	8.9	1.28	10.19	1.48	10.91	1.60	11.6	1.69	12.9	1.90	14.3	2.12
	10	7.5	1.13	8.9	1.33	10.19	1.55	10.91	1.66	11.6	1.77	12.9	1.99	14.3	2.23
	15	7.5	1.18	8.9	1.39	10.19	1.62	10.91	1.73	11.6	1.84	12.9	2.08	14.3	2.33
	20	7.5	1.22	8.9	1.45	10.19	1.68	10.91	1.81	11.6	1.93	12.9	2.19	14.3	2.44
	25	7.5	1.28	8.9	1.53	10.19	1.83	10.91	1.98	11.6	2.15	12.9	2.48	14.3	2.84
	30	7.5	1.49	8.9	1.82	10.19	2.17	10.91	2.35	11.6	2.54	12.9	2.94	14.3	3.37
	35	7.5	1.75	8.9	2.14	10.19	2.54	10.91	2.76	11.6	2.99	12.9	3.46	14.3	3.97
	41	7.5	2.04	8.9	2.48	10.19	2.96	10.91	3.22	11.6	3.49	12.9	4.04	14.3	4.64
43	7.5	2.21	8.9	2.52	10.19	3.21	10.91	3.57	11.6	3.80	12.9	4.32	14.3	5.05	
50%	5	6.3	0.91	7.4	1.08	8.52	1.22	9.08	1.29	9.6	1.38	10.8	1.57	11.9	1.74
	10	6.3	0.94	7.4	1.11	8.52	1.28	9.08	1.36	9.6	1.45	10.8	1.64	11.9	1.82
	15	6.3	0.98	7.4	1.13	8.52	1.33	9.08	1.42	9.6	1.52	10.8	1.71	11.9	1.90
	20	6.3	1.02	7.4	1.20	8.52	1.39	9.08	1.49	9.6	1.58	10.8	1.79	11.9	1.99
	25	6.3	1.07	7.4	1.25	8.52	1.46	9.08	1.57	9.6	1.70	10.8	1.95	11.9	2.22
	30	6.3	1.22	7.4	1.46	8.52	1.73	9.08	1.87	9.6	2.01	10.8	2.32	11.9	2.63
	35	6.3	1.43	7.4	1.72	8.52	2.04	9.08	2.19	9.6	2.37	10.8	2.72	11.9	3.09
	41	6.3	1.67	7.4	1.88	8.52	2.37	9.08	2.56	9.6	2.76	10.8	3.17	11.9	3.61
43	6.3	1.84	7.4	2.05	8.52	2.57	9.08	2.76	9.6	2.96	10.8	3.44	11.9	3.92	

AWAU-YCV080-H11 heating mode

capacity factor	outdoor temp.		indoor temp. °CDB											
			16.0		18.0		20.0		21.0		22.0		24.0	
	°CDB	°CWB	TC	PI	TC	PI	TC	PI	TC	PI	TC	PI	TC	PI
130	-14.7	-15.0	5.98	1.42	5.98	1.49	5.98	1.57	5.98	1.60	5.98	1.64	5.98	1.72
	-12.6	-13.0	6.28	1.48	6.28	1.56	6.28	1.63	6.28	1.66	6.28	1.70	6.28	1.77
	-10.5	-11.0	6.59	1.55	6.59	1.61	6.59	1.68	6.59	1.71	6.59	1.75	6.59	1.81
	-9.5	-10.0	6.87	1.58	6.87	1.64	6.87	1.70	6.87	1.74	6.87	1.77	6.87	1.84
	-8.5	-9.1	7.14	1.60	7.14	1.66	7.14	1.72	7.14	1.76	7.14	1.79	7.14	1.86
	-7.0	-7.6	7.47	1.64	7.47	1.70	7.47	1.76	7.47	1.79	7.47	1.82	7.47	1.88
	-5.0	-5.6	7.80	1.68	7.80	1.74	7.80	1.80	7.80	1.83	7.80	1.86	7.80	1.92
	-3.0	-3.7	8.11	1.72	8.11	1.78	8.11	1.84	8.11	1.87	8.11	1.89	8.11	1.96
	0.0	-0.7	8.49	1.78	8.49	1.84	8.49	1.89	8.49	1.91	8.49	1.94	8.49	2.00
	3.0	2.2	8.82	1.83	8.82	1.88	8.82	1.93	8.82	1.96	8.82	1.98	8.82	2.03
	5.0	4.1	9.17	1.86	9.17	1.91	9.17	1.96	9.17	1.98	9.17	2.01	9.17	2.05
	7.0	6.0	9.50	1.89	9.50	1.94	9.50	1.98	9.50	2.00	9.50	2.03	9.50	2.07
	9.0	7.9	9.85	1.91	9.85	1.96	9.85	2.00	9.85	2.03	9.85	2.05	9.85	2.09
	11.0	9.8	10.26	1.94	10.26	1.98	10.26	2.03	10.26	2.05	10.26	2.07	10.26	2.11
	13.0	11.8	10.41	1.96	10.41	2.00	10.41	2.05	10.41	2.07	10.41	2.09	10.41	2.13
	15.0	13.7	10.72	1.98	10.72	2.01	10.72	2.07	10.72	2.09	10.72	2.11	10.72	2.15
	19.0	14.2	10.72	2.01	10.72	2.05	10.72	2.09	10.72	2.11	10.72	2.13	10.72	2.09
21.0	15.0	10.72	2.05	10.72	2.09	10.72	2.11	10.72	2.13	10.72	2.15	10.72	2.00	
120	-14.7	-15.0	5.98	1.52	5.98	1.59	5.98	1.66	5.98	1.69	5.98	1.72	5.98	1.80
	-12.6	-13.0	6.28	1.58	6.28	1.65	6.28	1.71	6.28	1.74	6.28	1.77	6.28	1.84
	-10.5	-11.0	6.59	1.64	6.59	1.69	6.59	1.76	6.59	1.79	6.59	1.82	6.59	1.89
	-9.5	-10.0	6.87	1.67	6.87	1.72	6.87	1.78	6.87	1.81	6.87	1.84	6.87	1.91
	-8.5	-9.1	7.14	1.69	7.14	1.74	7.14	1.80	7.14	1.83	7.14	1.86	7.14	1.92
	-7.0	-7.6	7.47	1.72	7.47	1.78	7.47	1.83	7.47	1.86	7.47	1.89	7.47	1.96
	-5.0	-5.6	7.80	1.76	7.80	1.82	7.80	1.87	7.80	1.90	7.80	1.93	7.80	1.98
	-3.0	-3.7	8.11	1.80	8.11	1.85	8.11	1.91	8.11	1.94	8.11	1.96	8.11	2.01
	0.0	-0.7	8.49	1.85	8.49	1.90	8.49	1.96	8.49	1.98	8.49	2.00	8.49	1.94
	3.0	2.2	8.82	1.90	8.82	1.94	8.82	2.00	8.82	2.01	8.82	2.03	8.82	2.09
	5.0	4.1	9.17	1.93	9.17	1.98	9.17	2.01	9.17	2.03	9.17	2.05	9.17	2.11
	7.0	6.0	9.50	1.96	9.50	2.00	9.50	2.03	9.50	2.05	9.50	2.07	9.50	2.13
	9.0	7.9	9.85	1.98	9.85	2.01	9.85	2.05	9.85	2.07	9.85	2.09	9.93	2.15
	11.0	9.8	10.26	2.00	10.26	2.03	10.26	2.07	10.26	2.09	10.26	2.11	9.93	2.11
	13.0	11.8	10.41	2.01	10.41	2.05	10.41	2.09	10.41	2.11	10.41	2.13	9.93	2.03
	15.0	13.7	10.72	2.03	10.72	2.07	10.72	2.11	10.72	2.13	10.67	2.13	9.93	1.96
	19.0	14.2	10.72	2.09	10.72	2.13	10.72	2.15	10.72	2.11	10.67	2.07	9.93	1.94
21.0	15.0	10.72	2.13	10.72	2.09	10.72	2.07	10.72	2.05	10.67	2.00	9.93	1.91	
110	-14.7	-15.0	5.98	1.62	5.98	1.69	5.98	1.74	5.98	1.78	5.98	1.81	5.98	1.87
	-12.6	-13.0	6.28	1.68	6.28	1.74	6.28	1.79	6.28	1.83	6.28	1.86	6.28	1.92
	-10.5	-11.0	6.59	1.73	6.59	1.78	6.59	1.84	6.59	1.87	6.59	1.90	6.59	1.96
	-9.5	-10.0	6.87	1.75	6.87	1.81	6.87	1.86	6.87	1.89	6.87	1.92	6.87	1.98
	-8.5	-9.1	7.14	1.77	7.14	1.83	7.14	1.88	7.14	1.91	7.14	1.94	7.14	2.00
	-7.0	-7.6	7.47	1.80	7.47	1.86	7.47	1.91	7.47	1.93	7.47	1.96	7.47	2.01
	-5.0	-5.6	7.80	1.84	7.80	1.89	7.80	1.94	7.80	1.98	7.80	2.00	7.80	2.03
	-3.0	-3.7	8.11	1.88	8.11	1.93	8.11	1.98	8.11	2.00	8.11	2.03	8.11	2.07
	0.0	-0.7	8.49	1.93	8.49	1.98	8.49	2.01	8.49	2.03	8.49	2.05	8.49	2.11
	3.0	2.2	8.82	1.98	8.82	2.01	8.82	2.05	8.82	2.07	8.82	2.09	8.82	2.13
	5.0	4.1	9.17	2.00	9.17	2.03	9.17	2.07	9.17	2.09	9.17	2.11	9.12	2.13
	7.0	6.0	9.50	2.01	9.50	2.05	9.50	2.09	9.50	2.11	9.50	2.13	9.12	2.03

AWAU-YCV080-H11 heating mode

capacity factor	outdoor temp.		indoor temp. °CDB											
			16.0		18.0		20.0		21.0		22.0		24.0	
	°CDB	°CWB	TC	PI	TC	PI	TC	PI	TC	PI	TC	PI	TC	PI
			KW	KW	KW	KW	KW	KW	KW	KW	KW	KW	KW	KW
	9.0	7.9	9.85	2.03	9.85	2.07	9.85	2.11	9.85	2.13	9.78	2.09	9.12	1.98
	11.0	9.8	10.26	2.05	10.26	2.09	10.26	2.13	10.11	2.15	9.78	2.07	9.12	1.91
	13.0	11.8	10.41	2.07	10.41	2.11	10.41	2.15	10.11	2.07	9.78	2.00	9.12	1.84
	15.0	13.7	10.72	2.09	10.72	2.13	10.46	2.07	10.11	2.00	9.78	1.93	9.12	1.77
	19.0	14.2	10.72	2.13	10.72	2.09	10.46	2.00	10.11	1.91	9.78	1.83	9.12	1.74
	21.0	15.0	10.72	2.09	10.72	2.03	10.46	1.94	10.11	1.84	9.78	1.79	9.12	1.70
100	-14.7	-15.0	5.98	1.72	5.98	1.78	5.98	1.83	5.98	1.87	5.98	1.89	5.98	1.94
	-12.6	-13.0	6.28	1.77	6.28	1.83	6.28	1.88	6.28	1.91	6.28	1.94	6.28	2.00
	-10.5	-11.0	6.59	1.82	6.59	1.87	6.59	1.92	6.59	1.96	6.59	1.98	6.59	2.01
	-9.5	-10.0	6.87	1.84	6.87	1.89	6.87	1.94	6.87	1.96	6.87	2.00	6.87	2.03
	-8.5	-9.1	7.14	1.86	7.14	1.91	7.14	1.96	7.14	1.98	7.14	2.01	7.14	2.05
	-7.0	-7.6	7.47	1.89	7.47	1.94	7.47	1.98	7.47	2.01	7.47	2.03	7.47	2.07
	-5.0	-5.6	7.80	1.92	7.80	1.98	7.80	2.01	7.80	2.03	7.80	2.05	7.80	2.11
	-3.0	-3.7	8.11	1.96	8.11	2.00	8.11	2.03	8.11	2.05	8.11	2.09	8.11	2.13
	0.0	-0.7	8.49	2.00	8.49	2.03	8.49	2.07	8.49	2.09	8.49	2.11	8.26	2.11
	3.0	2.2	8.82	2.03	8.82	2.07	8.82	2.11	8.82	2.13	8.82	2.15	8.26	2.00
	5.0	4.1	9.17	2.05	9.17	2.09	9.17	2.13	9.17	2.15	8.89	2.07	8.26	1.91
	7.0	6.0	9.50	2.07	9.50	2.11	9.50	2.15	9.17	2.07	8.89	2.00	8.26	1.84
	9.0	7.9	9.85	2.09	9.80	2.13	9.50	2.07	9.17	2.00	8.89	1.92	8.26	1.77
	11.0	9.8	10.26	2.11	10.08	2.15	9.50	2.00	9.17	1.93	8.89	1.85	8.26	1.91
	13.0	11.8	10.41	2.13	10.08	2.05	9.50	1.93	9.17	1.85	8.89	1.79	8.26	1.66
	15.0	13.7	10.72	2.13	10.08	2.00	9.50	1.86	9.17	1.79	8.89	1.73	8.26	1.60
19.0	14.2	10.72	2.05	10.08	1.94	9.50	1.81	9.17	1.71	8.89	1.64	8.26	1.51	
21.0	15.0	10.72	2.01	10.08	1.87	9.50	1.74	9.17	1.65	8.89	1.55	8.26	1.45	
90	-14.7	-15.0	5.98	1.82	5.98	1.87	5.98	1.93	5.98	1.96	5.98	1.98	5.98	2.01
	-12.6	-13.0	6.28	1.87	6.28	1.92	6.28	1.96	6.28	2.00	6.28	2.00	6.28	2.05
	-10.5	-11.0	6.59	1.91	6.59	1.96	6.59	2.00	6.59	2.03	6.59	2.03	6.59	2.07
	-9.5	-10.0	6.87	1.93	6.87	1.98	6.87	2.03	6.87	2.05	6.87	2.05	6.87	2.11
	-8.5	-9.1	7.14	1.94	7.14	2.00	7.14	2.05	7.14	2.07	7.14	2.07	7.14	2.13
	-7.0	-7.6	7.47	1.98	7.47	2.01	7.47	2.07	7.47	2.09	7.47	2.11	7.47	2.15
	-5.0	-5.6	7.80	2.00	7.80	2.03	7.80	2.09	7.80	2.11	7.80	2.13	7.45	2.09
	-3.0	-3.7	8.11	2.03	8.11	2.07	8.11	2.11	8.11	2.13	8.11	2.15	7.45	2.03
	0.0	-0.7	8.49	2.07	8.49	2.11	8.49	2.15	8.26	2.09	7.98	2.05	7.45	1.84
	3.0	2.2	8.82	2.11	9.07	2.13	8.54	2.05	8.26	2.00	7.98	1.91	7.45	1.76
	5.0	4.1	9.17	2.13	9.07	2.13	8.54	1.98	8.26	1.91	7.98	1.84	7.45	1.70
	7.0	6.0	9.50	2.15	9.07	2.05	8.54	1.91	8.26	1.84	7.98	1.77	7.45	1.64
	9.0	7.9	9.63	2.11	9.07	1.98	8.54	1.84	8.26	1.77	7.98	1.71	7.45	1.58
	11.0	9.8	9.63	2.03	9.07	1.90	8.54	1.77	8.26	1.71	7.98	1.65	7.45	1.53
	13.0	11.8	9.63	1.96	9.07	1.83	8.54	1.71	8.26	1.66	7.98	1.60	7.45	1.48
	15.0	13.7	9.63	1.89	9.07	1.77	8.54	1.66	8.26	1.60	7.98	1.55	7.45	1.43
19.0	14.2	9.63	1.83	9.07	1.72	8.54	1.61	8.26	1.54	7.98	1.48	7.45	1.36	
21.0	15.0	9.63	1.74	9.07	1.62	8.54	1.56	8.26	1.47	7.98	1.39	7.45	1.31	
	-14.7	-15.0	5.98	1.92	5.98	1.98	5.98	2.01	5.98	2.03	5.98	2.05	5.98	2.09
	-12.6	-13.0	6.28	1.96	6.28	2.01	6.28	2.05	6.28	2.07	6.28	2.09	6.28	2.13
	-10.5	-11.0	6.59	2.00	6.59	2.03	6.59	2.07	6.59	2.09	6.59	2.13	6.61	2.13
	-9.5	-10.0	6.87	2.01	6.87	2.05	6.87	2.09	6.87	2.11	6.87	2.13	6.61	2.07
	-8.5	-9.1	7.14	2.03	7.14	2.07	7.14	2.11	7.14	2.13	7.14	2.15	6.61	2.00
	-7.0	-7.6	7.47	2.05	7.47	2.09	7.47	2.13	7.47	2.15	7.09	2.09	6.61	1.94

AWAU-YCV080-H11 heating mode

capacity factor	outdoor temp.		indoor temp. °CDB											
			16.0		18.0		20.0		21.0		22.0		24.0	
	°CDB	°CWB	TC	PI	TC	PI	TC	PI	TC	PI	TC	PI	TC	PI
			KW	KW	KW	KW	KW	KW	KW	KW	KW	KW	KW	KW
80	-5.0	-5.6	7.80	2.09	7.80	2.11	7.80	2.15	7.35	2.07	7.09	2.00	6.61	1.84
	-3.0	-3.7	8.11	2.11	8.11	2.15	7.60	2.05	7.35	1.98	7.09	1.91	6.61	1.76
	0.0	-0.7	8.49	2.15	8.06	2.03	7.60	1.92	7.35	1.85	7.09	1.78	6.61	1.65
	3.0	2.2	8.56	2.07	8.06	1.94	7.60	1.81	7.35	1.74	7.09	1.68	6.61	1.56
	5.0	4.1	8.56	2.00	8.06	1.86	7.60	1.73	7.35	1.68	7.09	1.62	6.61	1.50
	7.0	6.0	8.56	1.91	8.06	1.79	7.60	1.68	7.35	1.62	7.09	1.56	6.61	1.44
	9.0	7.9	8.56	1.84	8.06	1.73	7.60	1.62	7.35	1.56	7.09	1.51	6.61	1.39
	11.0	9.8	8.56	1.78	8.06	1.67	7.60	1.56	7.35	1.51	7.09	1.45	6.61	1.36
	13.0	11.8	8.56	1.72	8.06	1.61	7.60	1.51	7.35	1.45	7.09	1.40	6.61	1.31
	15.0	13.7	8.56	1.67	8.06	1.56	7.60	1.46	7.35	1.41	7.09	1.37	6.61	1.27
	19.0	14.2	8.56	1.61	8.06	1.51	7.60	1.42	7.35	1.35	7.09	1.31	6.61	1.21
	21.0	15.0	8.56	1.55	8.06	1.46	7.60	1.36	7.35	1.29	7.09	1.24	6.61	1.16
70	-14.7	-15.0	5.98	2.01	5.98	2.05	5.98	2.11	5.98	2.13	5.98	2.15	5.80	2.07
	-12.6	-13.0	6.28	2.05	6.28	2.09	6.28	2.13	6.28	2.15	6.21	2.09	5.80	1.96
	-10.5	-11.0	6.59	2.07	6.59	2.13	6.64	2.13	6.41	2.03	6.21	2.00	5.80	1.85
	-9.5	-10.0	6.87	2.09	6.87	2.13	6.64	2.07	6.41	2.00	6.21	1.94	5.80	1.78
	-8.5	-9.1	7.14	2.11	7.14	2.15	6.64	2.01	6.41	1.94	6.21	1.88	5.80	1.74
	-7.0	-7.6	7.47	2.13	7.07	2.07	6.64	1.96	6.41	1.88	6.21	1.81	5.80	1.68
	-5.0	-5.6	7.50	2.13	7.07	2.00	6.64	1.85	6.41	1.79	6.21	1.73	5.80	1.60
	-3.0	-3.7	7.50	2.03	7.07	1.90	6.64	1.77	6.41	1.71	6.21	1.65	5.80	1.53
	0.0	-0.7	7.50	1.89	7.07	1.77	6.64	1.66	6.41	1.60	6.21	1.55	5.80	1.43
	3.0	2.2	7.50	1.78	7.07	1.68	6.64	1.56	6.41	1.51	6.21	1.45	5.80	1.36
	5.0	4.1	7.50	1.71	7.07	1.61	6.64	1.50	6.41	1.45	6.21	1.40	5.80	1.31
	7.0	6.0	7.50	1.65	7.07	1.55	6.64	1.45	6.41	1.40	6.21	1.36	5.80	1.26
	9.0	7.9	7.50	1.60	7.07	1.50	6.64	1.40	6.41	1.36	6.21	1.31	5.80	1.22
	11.0	9.8	7.50	1.54	7.07	1.44	6.64	1.36	6.41	1.31	6.21	1.27	5.80	1.18
13.0	11.8	7.50	1.49	7.07	1.40	6.64	1.31	6.41	1.27	6.21	1.23	5.80	1.14	
15.0	13.7	7.50	1.44	7.07	1.36	6.64	1.28	6.41	1.23	6.21	1.19	5.80	1.11	
19.0	14.2	7.50	1.40	7.07	1.30	6.64	1.23	6.41	1.21	6.21	1.14	5.80	1.08	
21.0	15.0	7.50	1.33	7.07	1.22	6.64	1.16	6.41	1.12	6.21	1.08	5.80	1.01	
60	-14.7	-15.0	5.98	2.13	5.98	2.15	5.67	2.03	5.52	1.94	5.32	1.87	4.94	1.73
	-12.6	-13.0	6.28	2.15	6.05	2.03	5.67	1.90	5.52	1.83	5.32	1.77	4.94	1.64
	-10.5	-11.0	6.41	2.03	6.05	1.94	5.67	1.80	5.52	1.73	5.32	1.68	4.94	1.55
	-9.5	-10.0	6.41	2.00	6.05	1.87	5.67	1.74	5.52	1.69	5.32	1.63	4.94	1.51
	-8.5	-9.1	6.41	1.94	6.05	1.83	5.67	1.71	5.52	1.65	5.32	1.59	4.94	1.47
	-7.0	-7.6	6.41	1.88	6.05	1.76	5.67	1.65	5.52	1.59	5.32	1.55	4.94	1.42
	-5.0	-5.6	6.41	1.79	6.05	1.68	5.67	1.57	5.52	1.51	5.32	1.45	4.94	1.36
	-3.0	-3.7	6.41	1.72	6.05	1.60	5.67	1.50	5.52	1.45	5.32	1.40	4.94	1.30
	0.0	-0.7	6.41	1.60	6.05	1.50	5.67	1.41	5.52	1.36	5.32	1.31	4.94	1.22
	3.0	2.2	6.41	1.50	6.05	1.42	5.67	1.33	5.52	1.28	5.32	1.24	4.94	1.16
	5.0	4.1	6.41	1.45	6.05	1.37	5.67	1.28	5.52	1.24	5.32	1.20	4.94	1.12
	7.0	6.0	6.41	1.40	6.05	1.32	5.67	1.24	5.52	1.20	5.32	1.16	4.94	1.08
	9.0	7.9	6.41	1.36	6.05	1.28	5.67	1.20	5.52	1.16	5.32	1.12	4.94	1.05
	11.0	9.8	6.41	1.31	6.05	1.23	5.67	1.16	5.52	1.12	5.32	1.09	4.94	1.02
	13.0	11.8	6.41	1.27	6.05	1.19	5.67	1.12	5.52	1.09	5.32	1.06	4.94	0.99
	15.0	13.7	6.41	1.23	6.05	1.16	5.67	1.09	5.52	1.06	5.32	1.03	4.94	0.96
19.0	14.2	6.41	1.18	6.05	1.12	5.67	1.04	5.52	1.00	5.32	0.97	4.94	0.92	
21.0	15.0	6.41	1.12	6.05	1.07	5.67	1.00	5.52	0.97	5.32	0.94	4.94	0.87	

AWAU-YCV080-H11 heating mode

capacity factor	outdoor temp.		indoor temp. °CDB											
			16.0		18.0		20.0		21.0		22.0		24.0	
	°CDB	°CWB	TC	PI	TC	PI	TC	PI	TC	PI	TC	PI	TC	PI
50	-14.7	-15.0	5.35	1.88	5.04	1.76	4.74	1.65	4.59	1.59	4.43	1.54	4.13	1.42
	-12.6	-13.0	5.35	1.77	5.04	1.67	4.74	1.56	4.59	1.51	4.43	1.45	4.13	1.36
	-10.5	-11.0	5.35	1.68	5.04	1.58	4.74	1.48	4.59	1.43	4.43	1.38	4.13	1.28
	-9.5	-10.0	5.35	1.64	5.04	1.53	4.74	1.44	4.59	1.39	4.43	1.35	4.13	1.25
	-8.5	-9.1	5.35	1.60	5.04	1.50	4.74	1.40	4.59	1.36	4.43	1.31	4.13	1.22
	-7.0	-7.6	5.35	1.54	5.04	1.44	4.74	1.36	4.59	1.31	4.43	1.27	4.13	1.18
	-5.0	-5.6	5.35	1.47	5.04	1.38	4.74	1.29	4.59	1.25	4.43	1.21	4.13	1.13
	-3.0	-3.7	5.35	1.40	5.04	1.33	4.74	1.24	4.59	1.20	4.43	1.16	4.13	1.08
	0.0	-0.7	5.35	1.32	5.04	1.25	4.74	1.17	4.59	1.13	4.43	1.10	4.13	1.03
	3.0	2.2	5.35	1.25	5.04	1.18	4.74	1.11	4.59	1.08	4.43	1.04	4.13	0.97
	5.0	4.1	5.35	1.20	5.04	1.14	4.74	1.08	4.59	1.04	4.43	1.01	4.13	0.95
	7.0	6.0	5.35	1.16	5.04	1.10	4.74	1.04	4.59	1.01	4.43	0.98	4.13	0.91
	9.0	7.9	5.35	1.13	5.04	1.07	4.74	1.01	4.59	0.98	4.43	0.95	4.13	0.89
	11.0	9.8	5.35	1.09	5.04	1.04	4.74	0.98	4.59	0.95	4.43	0.92	4.13	0.86
	13.0	11.8	5.35	1.06	5.04	1.00	4.74	0.95	4.59	0.92	4.43	0.89	4.13	0.83
	15.0	13.7	5.35	1.03	5.04	0.98	4.74	0.92	4.59	0.90	4.43	0.87	4.13	0.81
19.0	14.2	5.35	1.00	5.04	0.94	4.74	0.87	4.59	0.85	4.43	0.83	4.13	0.79	
21.0	15.0	5.35	0.96	5.04	0.87	4.74	0.83	4.59	0.82	4.43	0.79	4.13	0.76	

AWAU-YCV180-H13 heating mode

capacity factor	outdoor temp.		indoor temp. °CDB											
			16.0		18.0		20.0		21.0		22.0		24.0	
	°CDB	°CWB	TC	PI	TC	PI	TC	PI	TC	PI	TC	PI	TC	PI
130	-14.7	-15.0	12.76	3.39	12.76	3.59	12.76	3.79	12.70	3.89	12.70	3.99	12.70	4.19
	-12.6	-13.0	13.40	3.47	13.40	3.65	13.40	3.83	13.40	3.92	13.40	4.01	13.40	4.19
	-10.5	-11.0	14.09	3.65	14.09	3.82	14.09	3.99	14.09	4.07	14.09	4.16	14.09	4.32
	-9.5	-10.0	14.48	3.73	14.48	3.90	14.48	4.06	14.48	4.15	14.48	4.23	14.48	4.40
	-8.5	-9.1	14.79	3.80	14.79	3.96	14.79	4.12	14.79	4.20	14.79	4.28	14.79	4.45
	-7.0	-7.6	15.36	3.91	15.36	4.06	15.36	4.22	15.36	4.32	15.36	4.36	15.36	4.53
	-5.0	-5.6	16.00	4.04	16.00	4.19	16.00	4.32	16.00	4.40	16.00	4.49	16.00	4.62
	-3.0	-3.7	16.63	4.16	16.63	4.28	16.63	4.45	16.63	4.53	16.63	4.57	16.63	4.74
	0.0	-0.7	17.71	4.32	17.71	4.45	17.71	4.57	17.71	4.66	17.71	4.70	17.71	4.83
	3.0	2.2	18.60	4.45	18.60	4.57	18.60	4.70	18.60	4.74	18.60	4.83	18.60	4.95
	5.0	4.1	19.36	4.53	19.36	4.66	19.36	4.78	19.36	4.83	19.36	4.91	19.36	5.00
	7.0	6.0	20.00	4.62	20.00	4.74	20.00	4.83	20.00	4.91	20.00	4.95	20.00	5.08
	9.0	7.9	20.70	4.66	20.63	4.78	20.63	4.91	20.63	4.95	20.63	5.00	20.63	5.12
	11.0	9.8	21.33	4.74	21.33	4.83	21.33	4.95	21.33	5.00	21.33	5.08	21.33	5.17
	13.0	11.8	22.03	4.78	22.03	4.91	22.03	5.00	22.03	5.08	22.03	5.12	22.03	5.21
	15.0	13.7	22.67	4.87	22.67	4.95	22.67	5.04	22.67	5.12	22.67	5.17	22.67	5.17
	19.0	14.2	22.67	4.91	22.67	5.01	22.67	5.09	22.67	5.17	22.67	5.21	22.67	5.06
21.0	15.0	22.67	4.95	22.67	5.06	22.67	5.13	22.67	5.20	22.67	5.13	22.67	5.01	
120	-14.7	-15.0	12.76	3.53	12.70	3.70	12.70	3.88	12.70	3.97	12.70	4.06	12.70	4.23
	-12.6	-13.0	13.40	3.71	13.40	3.88	13.40	4.05	13.40	4.13	13.40	4.22	13.40	4.40
	-10.5	-11.0	14.09	3.88	14.09	4.04	14.09	4.19	14.09	4.28	14.09	4.36	14.09	4.53
	-9.5	-10.0	14.48	3.95	14.48	4.11	14.48	4.28	14.48	4.32	14.48	4.40	14.48	4.57
	-8.5	-9.1	14.79	4.02	14.79	4.17	14.79	4.32	14.79	4.40	14.79	4.49	14.79	4.62
	-7.0	-7.6	15.36	4.12	15.36	4.28	15.36	4.40	15.36	4.49	15.36	4.53	15.36	4.70
	-5.0	-5.6	16.00	4.23	16.00	4.36	16.00	4.53	16.00	4.57	16.00	4.66	16.00	4.78
	-3.0	-3.7	16.63	4.36	16.63	4.49	16.63	4.62	16.63	4.66	16.63	4.74	16.63	4.87
	0.0	-0.7	17.71	4.49	17.71	4.62	17.71	4.74	17.71	4.78	17.71	4.87	17.71	5.00
	3.0	2.2	18.60	4.62	18.60	4.74	18.60	4.87	18.60	4.91	18.60	4.95	18.60	5.08
	5.0	4.1	19.36	4.70	19.36	4.78	19.36	4.91	19.36	4.95	19.36	5.04	19.36	5.12
	7.0	6.0	20.00	4.74	20.00	4.87	20.00	5.00	20.00	5.04	20.00	5.08	20.00	5.21
	9.0	7.9	20.63	4.83	20.63	4.91	20.63	5.04	20.63	5.08	20.63	5.12	20.63	5.25
	11.0	9.8	21.33	4.87	21.33	5.00	21.33	5.08	21.33	5.12	21.33	5.17	20.89	5.08
	13.0	11.8	22.03	4.95	22.03	5.04	22.03	5.12	22.03	5.17	22.03	5.25	20.89	4.91
	15.0	13.7	22.67	5.00	22.67	5.08	22.67	5.17	22.67	5.21	22.67	5.12	20.89	4.70
	19.0	14.2	22.67	5.04	22.67	5.12	22.67	5.17	22.67	5.16	22.67	5.04	20.89	4.59
21.0	15.0	22.67	5.09	22.67	5.16	22.67	5.20	22.67	5.12	22.67	4.88	20.89	4.50	
110	-14.7	-15.0	12.70	3.79	12.70	3.95	12.70	4.11	12.70	4.19	12.70	4.28	12.70	4.45
	-12.6	-13.0	13.40	3.96	13.40	4.11	13.40	4.28	13.40	4.36	13.40	4.40	13.40	4.57
	-10.5	-11.0	14.09	4.11	14.09	4.23	14.09	4.40	14.09	4.49	14.09	4.53	14.09	4.70
	-9.5	-10.0	14.48	4.18	14.48	4.32	14.48	4.45	14.48	4.53	14.48	4.62	14.48	4.74
	-8.5	-9.1	14.79	4.23	14.79	4.36	14.79	4.53	14.79	4.57	14.79	4.66	14.79	4.78
	-7.0	-7.6	15.36	4.32	15.36	4.45	15.36	4.57	15.36	4.66	15.36	4.74	15.36	4.87
	-5.0	-5.6	16.00	4.45	16.00	4.57	16.00	4.70	16.00	4.74	16.00	4.83	16.00	4.95
	-3.0	-3.7	16.63	4.53	16.63	4.66	16.63	4.78	16.63	4.83	16.63	4.91	16.63	5.00
	0.0	-0.7	17.71	4.66	17.65	4.78	17.65	4.91	17.65	4.95	17.65	5.00	17.65	5.12
	3.0	2.2	18.60	4.78	18.60	4.91	18.60	5.00	18.60	5.04	18.60	5.12	18.60	5.21
	5.0	4.1	19.36	4.87	19.36	4.95	19.36	5.04	19.36	5.12	19.36	5.17	19.17	5.21
	7.0	6.0	20.00	4.91	20.00	5.00	20.00	5.12	20.00	5.17	20.00	5.21	19.17	5.00
	9.0	7.9	20.63	5.00	20.63	5.08	20.63	5.17	20.63	5.21	20.51	5.21	19.17	4.78
	11.0	9.8	21.33	5.04	21.33	5.12	21.33	5.21	21.27	5.21	20.51	5.00	19.17	4.62
13.0	11.8	22.03	5.08	22.03	5.17	22.03	5.17	21.27	5.00	20.51	4.78	19.17	4.45	

AWAU-YCV180-H13 heating mode

capacity factor	outdoor temp.		indoor temp. °CDB												
			16.0		18.0		20.0		21.0		22.0		24.0		
	°CDB	°CWB	TC	PI	TC	PI	TC	PI	TC	PI	TC	PI	TC	PI	
			KW	KW	KW	KW	KW	KW	KW	KW	KW	KW	KW	KW	KW
	15.0	13.7	22.67	5.12	22.67	5.21	22.03	5.00	21.27	4.83	20.51	4.62	19.17	4.28	
	19.0	14.2	22.67	4.79	22.67	5.16	22.03	4.83	21.27	4.63	20.51	4.46	19.17	4.14	
	21.0	15.0	22.67	4.83	22.67	5.01	22.03	4.58	21.27	4.49	20.51	4.34	19.17	4.08	
100	-14.7	-15.0	12.70	4.05	12.70	4.20	12.70	4.36	12.70	4.40	12.70	4.49	12.70	4.66	
	-12.6	-13.0	13.40	4.20	13.40	4.36	13.40	4.49	13.40	4.53	13.40	4.62	13.40	4.74	
	-10.5	-11.0	14.09	4.36	14.09	4.49	14.09	4.62	14.09	4.66	14.09	4.74	14.09	4.87	
	-9.5	-10.0	14.48	4.40	14.48	4.53	14.48	4.66	14.48	4.74	14.48	4.78	14.48	4.91	
	-8.5	-9.1	14.79	4.45	14.79	4.57	14.79	4.70	14.79	4.78	14.79	4.83	14.79	4.95	
	-7.0	-7.6	15.36	4.53	15.36	4.66	15.36	4.78	15.36	4.83	15.36	4.91	15.36	5.04	
	-5.0	-5.6	16.00	4.66	16.00	4.74	16.00	4.87	16.00	4.91	16.00	5.00	16.00	5.08	
	-3.0	-3.7	16.63	4.74	16.63	4.83	16.63	4.95	16.63	5.00	16.63	5.04	16.63	5.17	
	0.0	-0.7	17.65	4.87	17.65	4.95	17.65	5.04	17.65	5.12	17.65	5.17	17.46	5.25	
	3.0	2.2	18.60	4.95	18.60	5.04	18.60	5.17	18.60	5.21	18.60	5.25	17.46	4.91	
	5.0	4.1	19.36	5.00	19.36	5.12	19.36	5.21	19.36	5.25	18.73	5.08	17.46	4.70	
	7.0	6.0	20.00	5.08	20.00	5.17	20.00	5.25	19.36	5.04	18.73	4.87	17.46	4.49	
	9.0	7.9	20.63	5.12	20.63	5.21	20.00	5.04	19.36	4.87	18.73	4.66	17.46	4.32	
	11.0	9.8	21.33	5.17	21.27	5.21	20.00	4.83	19.36	4.66	18.73	4.49	17.46	4.15	
	13.0	11.8	22.03	5.21	21.27	5.00	20.00	4.66	19.36	4.49	18.73	4.32	17.46	4.00	
	15.0	13.7	22.54	5.12	21.27	4.83	20.00	4.49	19.36	4.32	18.73	4.17	17.46	3.86	
	19.0	14.2	22.54	4.99	21.27	4.66	20.00	4.38	19.36	4.14	18.73	4.01	17.46	3.75	
	21.0	15.0	22.54	4.83	21.27	4.46	20.00	4.21	19.36	4.08	18.73	3.89	17.46	3.67	
	90	-14.7	-15.0	12.70	4.32	12.70	4.45	12.70	4.57	12.70	4.66	12.70	4.70	12.70	4.83
		-12.6	-13.0	13.40	4.45	13.40	4.57	13.40	4.70	13.40	4.74	13.40	4.83	13.40	4.95
-10.5		-11.0	14.09	4.57	14.09	4.70	14.09	4.83	14.09	4.87	14.09	4.91	14.09	5.04	
-9.5		-10.0	14.48	4.62	14.48	4.74	14.48	4.87	14.48	4.91	14.48	4.95	14.48	5.08	
-8.5		-9.1	14.79	4.66	14.79	4.78	14.79	4.91	14.79	4.95	14.79	5.00	14.79	5.12	
-7.0		-7.6	15.36	4.74	15.36	4.87	15.36	4.95	15.36	5.04	15.36	5.08	15.30	5.17	
-5.0		-5.6	16.00	4.83	16.00	4.95	16.00	5.04	16.00	5.08	16.00	5.17	15.62	5.25	
-3.0		-3.7	16.63	4.91	16.63	5.04	16.63	5.12	16.63	5.17	16.63	5.21	15.62	5.04	
0.0		-0.7	17.65	5.04	17.65	5.12	17.65	5.21	17.33	5.25	16.82	5.04	15.62	4.66	
3.0		2.2	18.60	5.12	18.60	5.21	17.97	5.08	17.33	4.91	16.82	4.70	15.62	4.36	
5.0		4.1	19.36	5.17	19.24	5.21	17.97	4.87	17.33	4.70	16.82	4.49	15.62	4.17	
7.0		6.0	20.00	5.21	19.24	5.00	17.97	4.66	17.33	4.49	16.82	4.32	15.62	4.00	
9.0		7.9	20.32	5.12	19.24	4.78	17.97	4.49	17.33	4.32	16.82	4.16	15.62	3.85	
11.0		9.8	20.32	4.91	19.24	4.62	17.97	4.32	17.33	4.15	16.82	4.00	15.62	3.71	
13.0		11.8	20.32	4.74	19.24	4.45	17.97	4.14	17.33	3.99	16.82	3.85	15.62	3.57	
15.0		13.7	20.32	4.57	19.24	4.28	17.97	3.99	17.33	3.86	16.82	3.72	15.62	3.45	
19.0		14.2	20.32	4.46	19.24	4.16	17.97	3.87	17.33	3.74	16.82	3.59	15.62	3.33	
21.0		15.0	20.32	4.30	19.24	4.00	17.97	3.80	17.33	3.62	16.82	3.46	15.62	3.19	
80		-14.7	-15.0	12.70	4.57	12.70	4.70	12.70	4.83	12.70	4.87	12.70	4.91	12.70	5.04
		-12.6	-13.0	13.40	4.70	13.40	4.78	13.40	4.91	13.40	4.95	13.40	5.04	13.40	5.12
	-10.5	-11.0	14.09	4.78	14.09	4.91	14.09	5.00	14.09	5.08	14.09	5.12	13.97	5.21	
	-9.5	-10.0	14.48	4.87	14.48	4.95	14.48	5.04	14.48	5.12	14.48	5.17	13.97	5.25	
	-8.5	-9.1	14.79	4.91	14.79	5.00	14.79	5.08	14.79	5.17	14.79	5.21	13.97	5.17	
	-7.0	-7.6	15.36	4.95	15.36	5.04	15.30	5.17	15.30	5.21	14.98	5.25	13.97	4.91	
	-5.0	-5.6	16.00	5.04	16.00	5.12	16.00	5.21	15.43	5.25	14.98	5.04	13.97	4.66	
	-3.0	-3.7	16.63	5.12	16.63	5.21	16.00	5.17	15.43	4.95	14.98	4.78	13.97	4.40	
	0.0	-0.7	17.65	5.21	17.02	5.12	16.00	4.78	15.43	4.62	14.98	4.40	13.97	4.09	
	3.0	2.2	17.97	5.08	17.02	4.78	16.00	4.45	15.43	4.28	14.98	4.13	13.97	3.83	
	5.0	4.1	17.97	4.87	17.02	4.57	16.00	4.28	15.43	4.11	14.98	3.96	13.97	3.67	
	7.0	6.0	17.97	4.66	17.02	4.36	16.00	4.09	15.43	3.95	14.98	3.81	13.97	3.53	

AWAU-YCV180-H13 heating mode

capacity factor	outdoor temp.		indoor temp. °CDB											
			16.0		18.0		20.0		21.0		22.0		24.0	
	°CDB	°CWB	TC	PI	TC	PI	TC	PI	TC	PI	TC	PI	TC	PI
	9.0	7.9	17.97	4.49	17.02	4.20	16.00	3.93	15.43	3.79	14.98	3.66	13.97	3.40
	11.0	9.8	17.97	4.32	17.02	4.05	16.00	3.79	15.43	3.66	14.98	3.53	13.97	3.28
	13.0	11.8	17.97	4.15	17.02	3.90	16.00	3.65	15.43	3.52	14.98	3.40	13.97	3.16
	15.0	13.7	17.97	4.01	17.02	3.73	16.00	3.52	15.43	3.40	14.98	3.29	13.97	3.06
	19.0	14.2	17.97	3.87	17.02	3.66	16.00	3.38	15.43	3.28	14.98	3.15	13.97	2.99
	21.0	15.0	17.97	3.76	17.02	3.50	16.00	3.29	15.43	3.17	14.98	3.04	13.97	2.83
70	-14.7	-15.0	12.70	4.83	12.70	4.95	12.70	5.04	12.70	5.08	12.70	5.12	12.19	5.25
	-12.6	-13.0	13.40	4.95	13.40	5.04	13.40	5.12	13.40	5.17	13.08	5.25	12.19	5.04
	-10.5	-11.0	14.09	5.04	14.09	5.12	14.03	5.21	13.52	5.25	13.08	5.08	12.19	4.70
	-9.5	-10.0	14.48	5.08	14.48	5.17	14.03	5.25	13.52	5.12	13.08	4.91	12.19	4.53
	-8.5	-9.1	14.79	5.12	14.79	5.21	14.03	5.17	13.52	5.00	13.08	4.78	12.19	4.45
	-7.0	-7.6	15.30	5.17	14.92	5.25	14.03	4.95	13.52	4.74	13.08	4.57	12.19	4.23
	-5.0	-5.6	15.81	5.25	14.92	5.00	14.03	4.66	13.52	4.49	13.08	4.32	12.19	4.01
	-3.0	-3.7	15.81	5.08	14.92	4.74	14.03	4.45	13.52	4.28	13.08	4.12	12.19	3.81
	0.0	-0.7	15.81	4.70	14.92	4.40	14.03	4.11	13.52	3.97	13.08	3.82	12.19	3.55
	3.0	2.2	15.81	4.40	14.92	4.11	14.03	3.84	13.52	3.71	13.08	3.58	12.19	3.32
	5.0	4.1	15.81	4.20	14.92	3.94	14.03	3.69	13.52	3.56	13.08	3.44	12.19	3.20
	7.0	6.0	15.81	4.03	14.92	3.79	14.03	3.54	13.52	3.43	13.08	3.31	12.19	3.08
	9.0	7.9	15.81	3.88	14.92	3.64	14.03	3.41	13.52	3.30	13.08	3.19	12.19	2.97
	11.0	9.8	15.81	3.73	14.92	3.51	14.03	3.29	13.52	3.18	13.08	3.05	12.19	2.87
	13.0	11.8	15.81	3.60	14.92	3.38	14.03	3.18	13.52	3.07	13.08	2.97	12.19	2.77
15.0	13.7	15.81	3.48	14.92	3.27	14.03	3.07	13.52	2.97	13.08	2.87	12.19	2.68	
19.0	14.2	15.81	3.30	14.92	3.18	14.03	2.99	13.52	2.84	13.08	2.71	12.19	2.57	
21.0	15.0	15.81	3.18	14.92	3.03	14.03	2.85	13.52	2.70	13.08	2.58	12.19	2.43	
60	-14.7	-15.0	12.70	5.08	12.70	5.17	12.00	5.25	11.62	5.08	11.24	4.91	10.48	4.53
	-12.6	-13.0	13.40	5.17	12.76	5.25	12.00	4.91	11.62	4.74	11.24	4.57	10.48	4.23
	-10.5	-11.0	13.52	5.25	12.76	4.95	12.00	4.62	11.62	4.45	11.24	4.28	10.48	3.96
	-9.5	-10.0	13.52	5.12	12.76	4.78	12.00	4.49	11.62	4.32	11.24	4.15	10.48	3.84
	-8.5	-9.1	13.52	5.00	12.76	4.66	12.00	4.36	11.62	4.20	11.24	4.04	10.48	3.75
	-7.0	-7.6	13.52	4.74	12.76	4.45	12.00	4.16	11.62	4.01	11.24	3.87	10.48	3.59
	-5.0	-5.6	13.52	4.49	12.76	4.21	12.00	3.94	11.62	3.80	11.24	3.67	10.48	3.40
	-3.0	-3.7	13.52	4.28	12.76	4.01	12.00	3.75	11.62	3.62	11.24	3.49	10.48	3.25
	0.0	-0.7	13.52	3.96	12.76	3.72	12.00	3.48	11.62	3.37	11.24	3.26	10.48	3.03
	3.0	2.2	13.52	3.71	12.76	3.48	12.00	3.27	11.62	3.16	11.24	3.06	10.48	2.85
	5.0	4.1	13.52	3.56	12.76	3.35	12.00	3.14	11.62	3.04	11.24	2.94	10.48	2.74
	7.0	6.0	13.52	3.42	12.76	3.22	12.00	3.03	11.62	2.93	11.24	2.83	10.48	2.64
	9.0	7.9	13.52	3.30	12.76	3.11	12.00	2.92	11.62	2.83	11.24	2.74	10.48	2.55
	11.0	9.8	13.52	3.18	12.76	3.00	12.00	2.82	11.62	2.73	11.24	2.64	10.48	2.47
	13.0	11.8	13.52	3.07	12.76	2.90	12.00	2.72	11.62	2.64	11.24	2.56	10.48	2.39
15.0	13.7	13.52	2.97	12.76	2.80	12.00	2.64	11.62	2.56	11.24	2.48	10.48	2.32	
19.0	14.2	13.52	2.89	12.76	2.67	12.00	2.56	11.62	2.48	11.24	2.39	10.48	2.22	
21.0	15.0	13.52	2.77	12.76	2.59	12.00	2.45	11.62	2.40	11.24	2.31	10.48	2.13	
50	-14.7	-15.0	11.30	4.91	10.67	4.62	10.03	4.32	9.65	4.16	9.33	4.01	8.70	3.71
	-12.6	-13.0	11.30	4.62	10.67	4.32	10.03	4.02	9.65	3.89	9.33	3.75	8.70	3.48
	-10.5	-11.0	11.30	4.32	10.67	4.04	10.03	3.78	9.65	3.65	9.33	3.52	8.70	3.27
	-9.5	-10.0	11.30	4.17	10.67	3.92	10.03	3.67	9.65	3.54	9.33	3.42	8.70	3.18
	-8.5	-9.1	11.30	4.06	10.67	3.81	10.03	3.57	9.65	3.45	9.33	3.33	8.70	3.10
	-7.0	-7.6	11.30	3.90	10.67	3.66	10.03	3.43	9.65	3.31	9.33	3.20	8.70	2.98
	-5.0	-5.6	11.30	3.69	10.67	3.47	10.03	3.25	9.65	3.15	9.33	3.04	8.70	2.83
	-3.0	-3.7	11.30	3.51	10.67	3.31	10.03	3.10	9.65	3.00	9.33	2.90	8.70	2.71
	0.0	-0.7	11.30	3.27	10.67	3.08	10.03	2.90	9.65	2.81	9.33	2.71	8.70	2.54

AWAU-YCV180-H13 heating mode

capacity factor	outdoor temp.		indoor temp. °CDB											
			16.0		18.0		20.0		21.0		22.0		24.0	
	°CDB	°CWB	TC	PI	TC	PI	TC	PI	TC	PI	TC	PI	TC	PI
	3.0	2.2	11.30	3.07	10.67	2.90	10.03	2.73	9.65	2.64	9.33	2.56	8.70	2.39
	5.0	4.1	11.30	2.96	10.67	2.79	10.03	2.63	9.65	2.54	9.33	2.42	8.70	2.31
	7.0	6.0	11.30	2.85	10.67	2.69	10.03	2.53	9.65	2.46	9.33	2.38	8.70	2.23
	9.0	7.9	11.30	2.75	10.67	2.60	10.03	2.45	9.65	2.38	9.33	2.30	8.70	2.16
	11.0	9.8	11.30	2.65	10.67	2.51	10.03	2.37	9.65	2.30	9.33	2.23	8.70	2.09
	13.0	11.8	11.30	2.57	10.67	2.43	10.03	2.29	9.65	2.23	9.33	2.16	8.70	2.03
	15.0	13.7	11.30	2.49	10.67	2.36	10.03	2.23	9.65	2.16	9.33	2.10	8.70	1.97
	19.0	14.2	11.30	2.41	10.67	2.27	10.03	2.15	9.65	2.07	9.33	2.03	8.70	1.89
	21.0	15.0	11.30	2.25	10.67	2.20	10.03	2.09	9.65	1.98	9.33	1.95	8.70	1.81

8. Performance curves

8.1 Running range

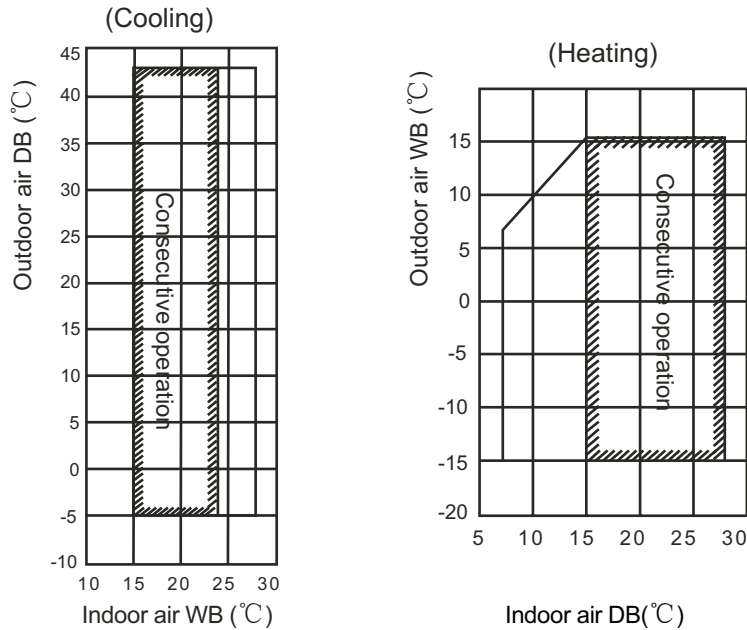

8.2 Calculation method

(1) Calculation method of refrigerating capacity---Refrigerating capacity to be known

=Refrigerating capacity x (A x B x C x D x E) W

A. Capacity compensation value of indoor air wet-bulb temperature condition

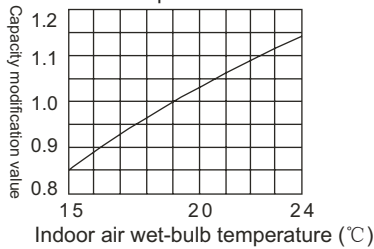

B. Capacity compensation value of outdoor air dry-bulb temperature condition

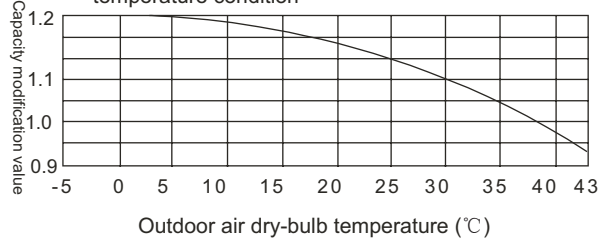

C. Fall of refrigerant pipe of indoor and outdoor unit, capacity compensation value of pipe length

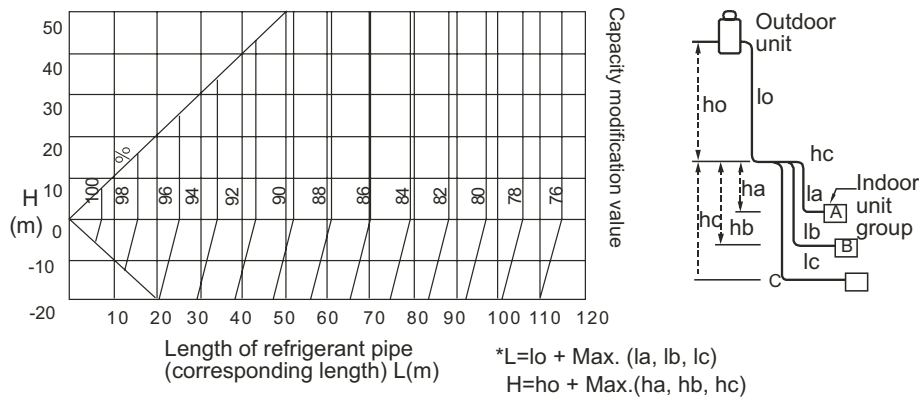

D. Capacity modification value under airflow variation rate of indoor unit group (only for duct unit)

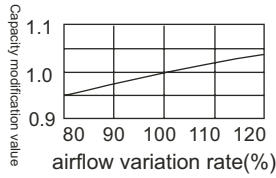

E. Capacity compensation suitable for total capacity of indoor unit group (cooling)

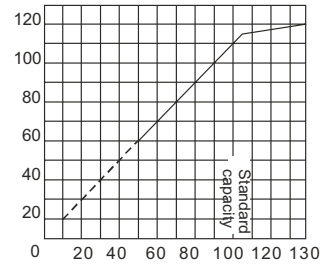

Total capacity of indoor unit group(%)

(2) Calculation method of heating capacity---Heating capacity to be known

= Heating capacityx (A x B x C x D x E x F) W

A. Capacity modification under indoor air dry-bulb temperature condition

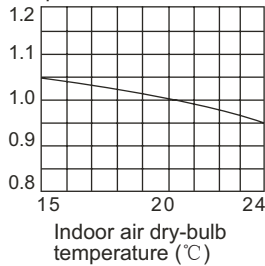

B. Capacity modification under outdoor air wet-bulb temperature condition

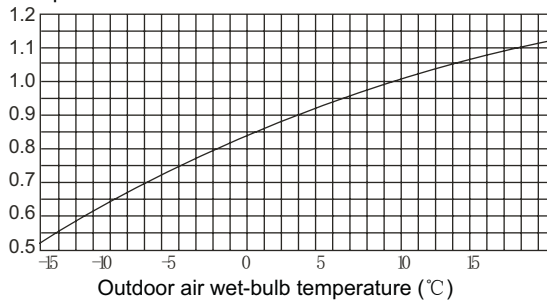

C. Capacity modification value under airflow variation rate of indoor unit group

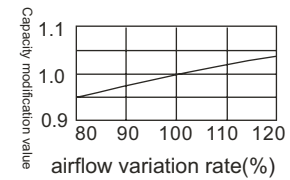

D. Fall of refrigerant pipe of indoor and outdoor unit, capacity compensation value of pipe length

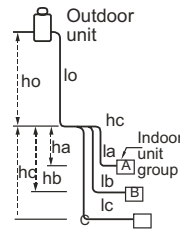
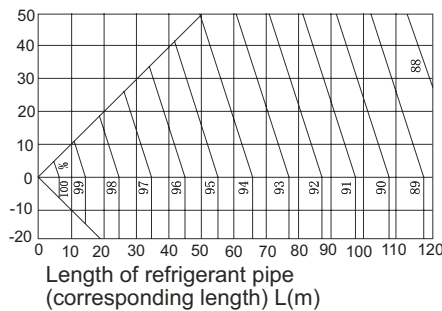

$$*L = lo + \text{Max.}(la, lb, lc)$$

$$H = ho + \text{Max.}(ha, hb, hc)$$

E. Capacity compensation suitable for total capacity of indoor unit group (heating)

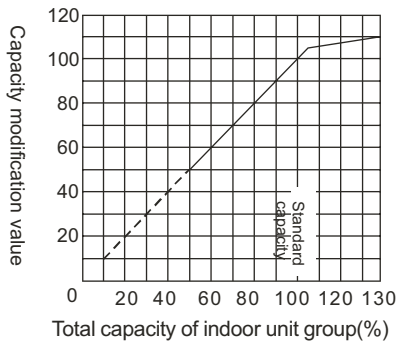

F. Capacity compensation value for defrost capability of outdoor heat exchanger

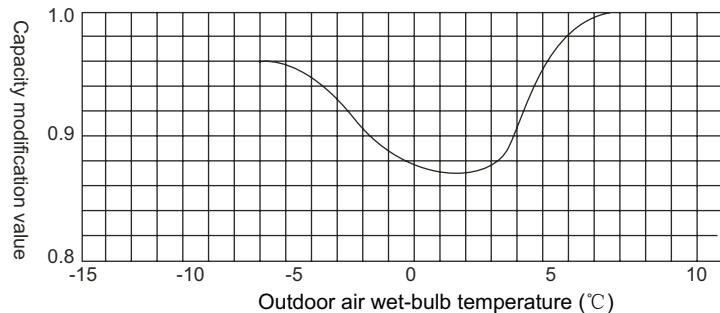

(3) Calculation method of refrigerating capacity---Only one indoor unit running

$$\text{Outdoor modified capacity with a single indoor running} = \text{outdoor modified capacity} * \frac{\text{standby indoor nominal capacity}}{\text{Indoor total nominal capacity}}$$

(Outdoor modified capacity: heating or cooling capacity after modify item 1 and 2)

9. Outdoor installation

9.1 Installation cautions

SAFETY PRECAUTIONS

Please read these "Safety Precautions" firstly then accurately execute the installation work.

Though the precautionary points indicated herein are divided under two headings, "WARNING" and "CAUTION", those points which are related to the strong possibility of an installation done in error resulting in death or serious injury are listed in the "WARNING" section. However, there is also a possibility of serious consequences in relationship to the points listed in the "CAUTION" section as well. In either case, important safety related information is indicated, so by all means, properly observe all that is mentioned.

After completing the installation, along with confirming that no abnormalities were seen from the operation tests, please

explain operating methods as well as maintenance methods to the user (customer) of this equipment, based on the owner's manual.

Moreover, ask the customer to keep this sheet together with the owner's manual.

WARNING

This system should be applied to places of office, restaurant, residence and the like. Application to inferior environment such as engineering shop could cause equipment malfunction.

Please entrust installation to either the company which sold you the equipment or to a professional contractor. Defects from improper installations can be the cause of water leakage, electric shocks and fires.

Execute the installation accurately, based on following the installation manual. Again, improper installations can result in water leakage, electric shocks and fires.

When a large air-conditioning system is installed to a small room, it is necessary to have a prior planned countermeasure for the rare case of a refrigerant leakage, to prevent the exceeding of threshold concentration. In regards to preparing this countermeasure, consult with the company from which you purchased the equipment, and make the installation accordingly. In the rare event that a refrigerant leakage and exceeding of threshold concentration does occur, there is the danger of a resultant oxygen deficiency accident.

For installation, confirm that the installation site can sufficiently support heavy weight. When strength is insufficient, injury can result from a falling of the unit.

Execute the prescribed installation construction to prepare for earthquakes and the strong winds of typhoons and hurricanes, etc. Improper installations can result in accidents due to a violent falling over of the unit.

For electrical work, please see that a licensed electrician executes the work while following the safety standards related to electrical equipment, and local regulations as well as the installation instructions, and that only exclusive

use circuits are used. Insufficient power source circuit capacity and defective installment execution can be the cause of electric shocks and fires.

Accurately connect wiring using the proper cable, and insure that the external force of the cable is not conducted to the terminal connection part, through properly securing it. Improper connection or securing can result in heat generation or fire.

Take care that wiring does not rise upward, and accurately install the lid/service panel. Its improper installation can also result in heat generation or fire.

When setting up or moving the location of the air conditioner, do not mix air etc. or anything other than the designated refrigerant (please see nameplate) within the refrigeration cycle.

Rupture and injury caused by abnormal high pressure can result from such mixing.

Always use accessory parts and authorized parts for installation construction. Using parts not authorized by this company can result in water leakage, electric shock, fire and refrigerant leakage.

CAUTION

Execute proper grounding. Do not connect the ground wire to a gas pipe, water pipe, lightening rod or a telephone ground wire.

Improper placement of ground wires can result in electric shock.

The installation of an earth leakage breaker is necessary depending on the established location of the unit.

Not installing an earth leakage breaker may result in electric shock.

Do not install the unit where there is a concern about leakage of combustible gas. The rare event of leaked gas collecting around the unit could result in an outbreak of fire.

For the drain pipe, follow the installation manual to insure that it allows proper drainage and thermally insulate it to prevent condensation. Inadequate plumbing can result in water leakage and water damage to interior items.

9.2 Refrigerant piping

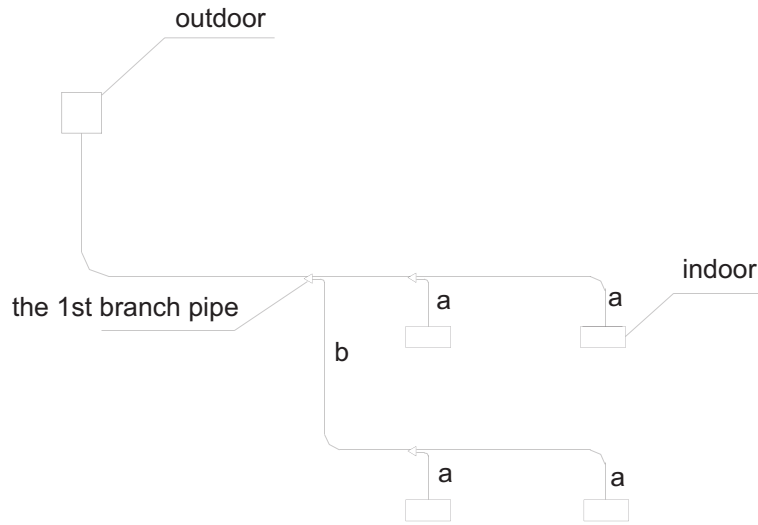

a. Pipe "a" diameter (between indoor and branch pipe) (depends on indoor pipe)

Indoor(*100W)	Gas pipe	Liquid pipe
22~28	∅9.52	∅6.35
36~56	∅12.7	∅6.35
71	∅15.88	∅9.52

b. Pipe "b" diameter (between branch pipes)

The branch pipe diameter depends on the total capacity of indoors connected with it. If indoor capacity is more than outdoor capacity, it is confirmed by the outdoor capacity.

Total indoor capacity after the branch pipe(100W)	Gas pipe	Liquid pipe
less than 101	∅15.88	∅9.52
not less than 101	∅19.05	∅9.52

c. Pipe "c" diameter (main pipe, between outdoor gather pipe and the first branch pipe)

Model	Gas pipe side		Liquid pipe side	
	Diameter	Connecting method	Diameter	Connecting method
AWAU-YCV080-H1	∅15.88	Flared joint	∅9.52	Flared joint
AWAU-YCV180-H13	∅19.05		∅9.52	

d. Copper pipe selection:

hardness	softness				Half-hardness			
Outer diameter	∅6.35	∅9.52	∅12.7	∅15.88	∅19.05	∅22.22	∅25.24	∅28.58
Min. thickness	0.8	0.8	1.0	1.0	1.0	1.1	1.2	1.4

Note: If the copper pipe with outer diameter 19.05 is coil pipe, the thickness should be over 1.1.

9.3 Allowable pipe length and drop

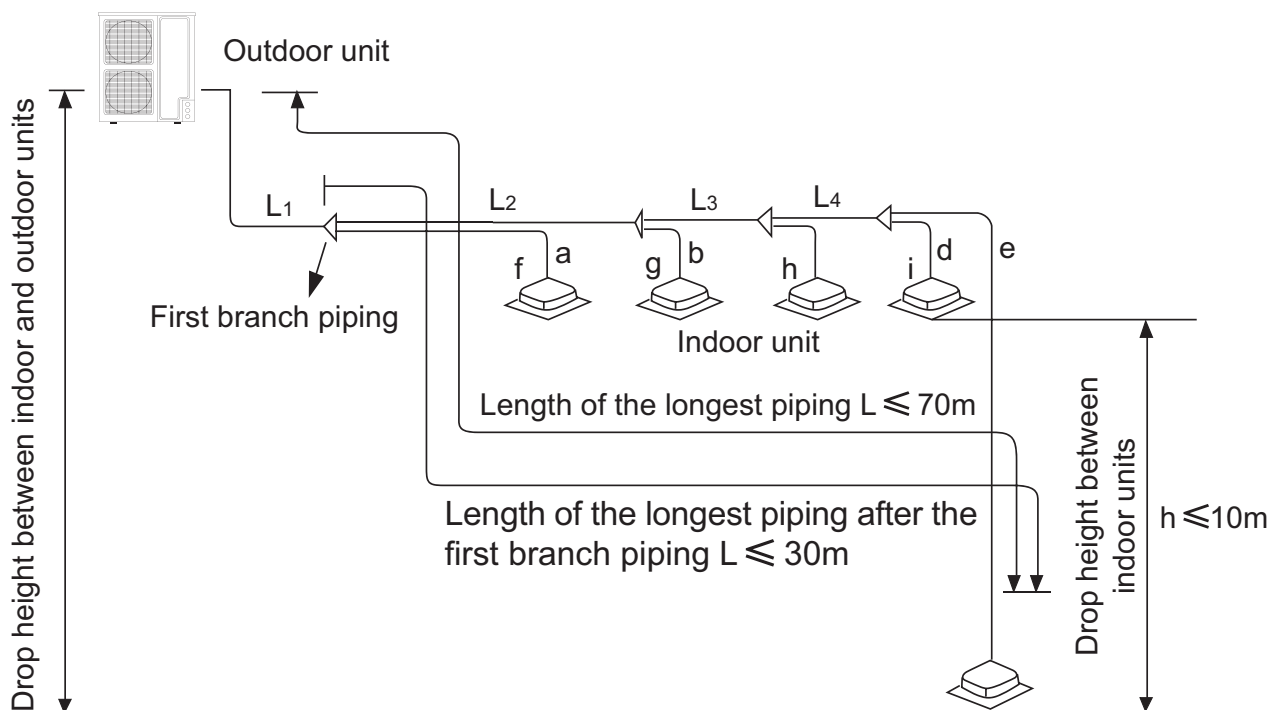

AWAU-YCV080-H11:

		allowable value	Piping part	
Length	Total length of piping (actual length)	50m	$L1+L2+a+b+c$	
	Longest piping L	Actual length	35m	$L1+L2+c$
	Max. pipe length from 1 st branch pipe to indoor	15m	$L2+c$	
Drop	Drop between indoor and outdoor unit H	Outdoor is upper	30m	---
		Outdoor is lower	20m	---
	Drop between indoor units h	10m	---	

AWAU-YCV180-H13

		allowable value	Piping part	
	Total length of piping (actual length)	100m	$L1+L2+L3+L4+a+b+c+d+e$	
	Longest piping L	Actual length	70m	$L1+L2+L3+L4+e$
	Max. pipe length from 1 st branch pipe to indoor	30m	$L2+L3+L4+e$	
Drop	Drop between indoor and outdoor unit H	Outdoor is upper	30m	---
		Outdoor is lower	20m	---
	Drop between indoor units h	10m	---	

9.4 Branch pipe dimension

unit: mm, ID: inner diameter; OD: outer diameter

	Side	Gas side	Changing pipe
TAU335	Gas Pipe		
	Liquid Pipe		

Branch pipe selection:

total indoor capacity(100W)	model(optional)
less than 335	TAU335

Note:

1. When connecting the pipe and the outdoor, please pay attention to the outdoor pipe dimension.
2. When adjusting the diameter among pipes and among the units, please must execute at the branch pipe side.
3. When welding with hard solder, please must blow nitrogen. If not, a number of oxide will be produced and cause heavy damage. Besides, to prevent water and dust into the pipe, please make the brim as outer roll.

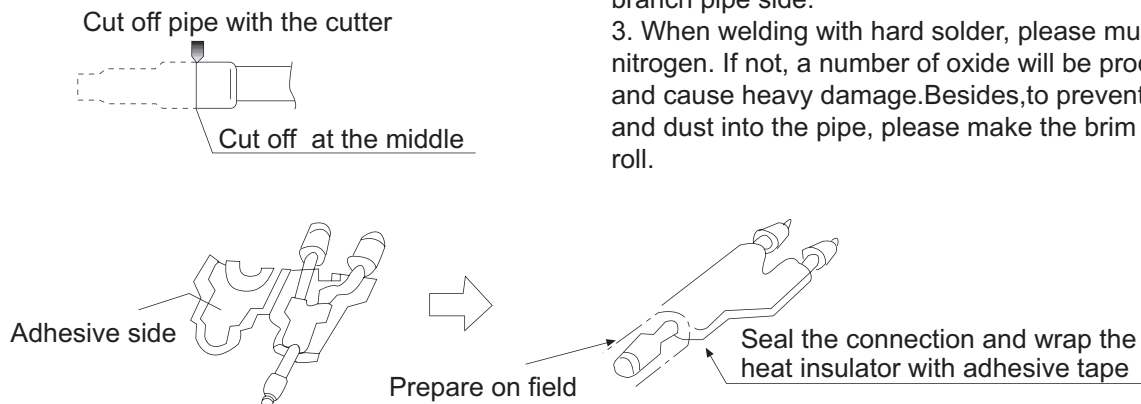

9.5 Piping installation

Important

- Please don't let the pipe and the parts in the unit collide each other.
- When connecting the pipes, close the valves fully.
- Protect the pipe end against the water, impurity into the pipes (welding after being flat, or being sealed with adhesive tape).
- Bend the pipe as large semi-diameter as possible(over 4 times of the pipe diameter).
- The connection between outdoor liquid pipe and the distributing pipe is flared type. Please expand the pipe with the special tool for R410A after installing the expanding nut. But if the projecting pipe length has been adjusted with the copper pipe gauge, you can use the original tool to expand the pipe.
- Since the unit is with R410A, the expanding oil is ester oil, not the mineral oil.
- When connecting the expanding pipe, fasten the pipes with double-spanner. The torque refers to the former info.

Expanding pipe:A(mm)		Projecting length of pipe to be expanded:B(mm)	when it is hard pipe	
pipe outer diameter	A 0 -0.4		special tool for R410A	the former tool
∅6.35	9.1	0-0.5	1.0-1.5	
∅9.52	13.2			
∅12.7	16.6			
∅15.88	19.7			

- The outdoor gas pipe and the refrigerant distributing pipe, as well the refrigerant distributing pipe and the branch pipe should be welded with hard solder.
- Weld the pipe at the same time charge the nitrogen. Or it will cause a number of impurity (a film of oxidation) to clog the capillary and the expansion valve, further cause the deadly failure.

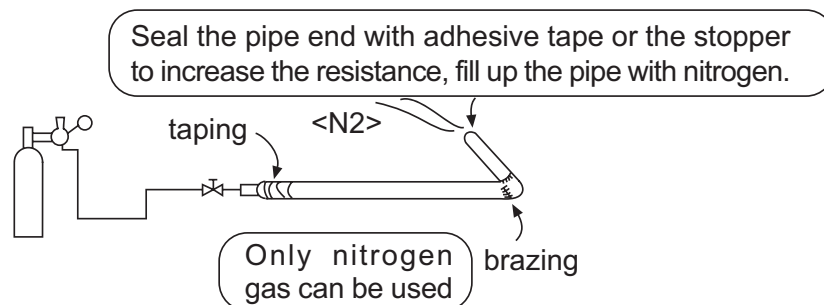

- Protect the pipe end against the water, impurity into the pipes (welding after being flat, or being sealed with adhesive tape).

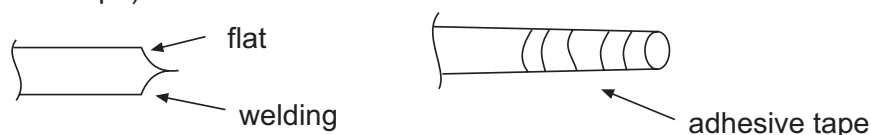

- The refrigerant pipe should be clean. The nitrogen should flow under the pressure of about 0.2Mpa and when charging the nitrogen, stop up the end of the pipe by hand to enhance the pressure in the pipe, then loose the hand (meanwhile stop up the other end).

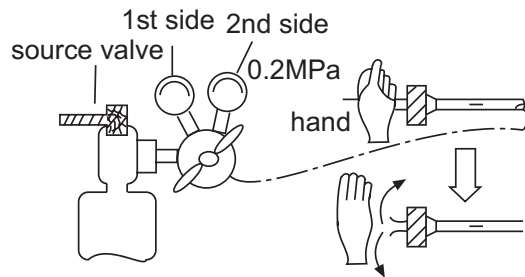

- When connecting the pipes, close the valves fully.
- When welding the valve and the pipes, use the wet cloth to cool down the valve and the pipes.

9.6 Leakage test

1. The outdoor unit has been executed the leakage test in the factory. After connecting the distributing pipe, execute the leakage test from the outdoor check valve and the indoor. Besides, while testing, the valves should be close.

2. Refer to the below figure to charge the nitrogen into the unit to take a test. Never use the chlorin, oxygen, flammable gas in the leakage test. Apply pressure both on the gas pipe and the liquid pipe.

3. Apply the pressure step by step to the target pressure.

a. Apply the pressure to 0.5MPa for more than 5 minutes, confirm if pressure goes down.

b. Apply the pressure to 1.5MPa for more than 5 minutes, confirm if pressure goes down.

c. Apply the pressure to the target pressure (4.0MPa), record the temp. and the pressure.

d. Leave it at 4.0MPa for over 1 day, if pressure does not go down, the test is passed. Meanwhile, when the temp. changes for 1degree, pressure will change 0.01MPa as well. Correct the pressure.

e. After confirmation of a~d, if pressure goes down, there is leakage. Check the brazing position, flared position by laying on the soap. modify the leakage point and take another leakage test.

4. After leakage test, must execute the evacuation.

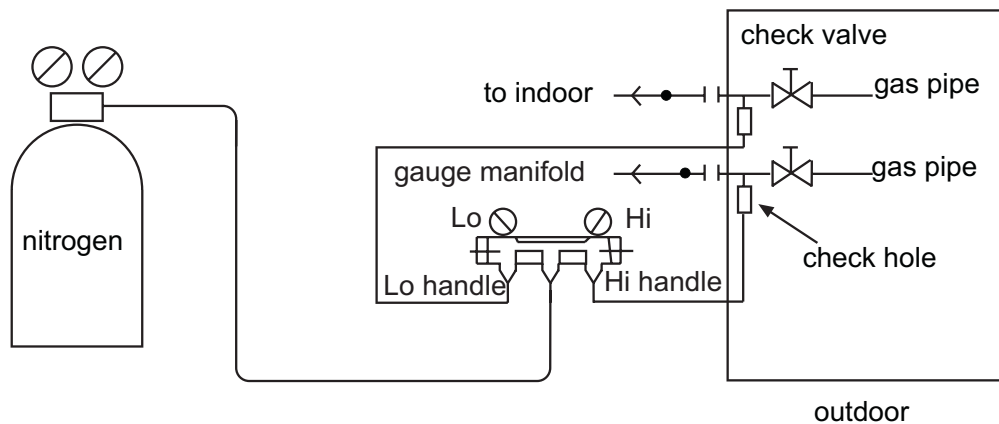

9.7 Evacuation

Evacuate at the check valve of liquid stop valve and both sides of the gas stop valve.

Operation procedure:

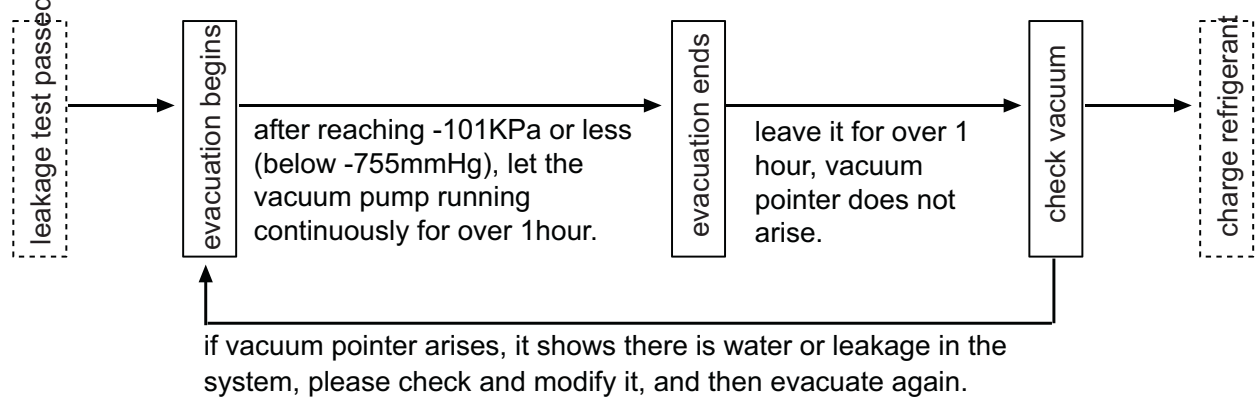

Because the unit is with refrigerant R410A, the below issues should be paid attention:

- To prevent the different oil into the pipe, please use the special tool for R410A, especially for gauge manifold and charging hose.
- To prevent the compressor oil into the refrigerant cycle, please use the anti-counter-flow adapter.

D. Check valve operation

Open/close method:

- Take down the valve cap.
- Turn the liquid stop valve and the gas stop valve with hexangular spanner until it stops. If opening the valve strongly, the valve will be damaged.
- Tighten the valve cap.

Tighten torque as the table below:

Tighten torque N.m			
	shaft (valve body)	cap (cover)	T-shape nut (check joint)
for gas pipe	less than 7	less than 30	13
for liquid pipe	7.85 (MAX15.7)	29.4 (MAX39.2)	8.8 (MAX14.7)

9.8 Additional refrigerant charging

Charge the additional refrigerant as liquid state with the gauge.

If the additional refrigerant can not be charged totally when the outdoor stops, charge it at the trial mode. If the unit runs for a long period in the state of lack of refrigerant, compressor will occur failure. (the charging must be finished within 30 minutes especially when the unit is running, meanwhile charging the refrigerant).

- A. Charging amount when out of factory excludes the refrigerant in the pipe.
 B. The unit only is charged the standard volume of refrigerant (distributing pipe length is 0m). Additional charging amount=actual length of liquid pipe x additional amount per meter liquid pipe
 Additional charging amount= $L1*0.35+L2*0.25+L3*0.17+L4*0.11+L5*0.054+L6*0.022$
 L1: total length of 22.22 liquid pipe L2: total length of 19.05 liquid pipe
 L3: total length of 15.88 liquid pipe L4: total length of 12.7 liquid pipe
 L5: total length of 9.52 liquid pipe L6:total length of 6.35 liquid pipe

C. Refrigerant charging and additional charging

Model	additional refrigerant charging per meter(kg/m)						charge when out of factory
	Ø22.22	Ø19.05	Ø15.88	Ø12.7	Ø9.52	Ø6.35	
AWAU-YCV080-H11	0.35	0.25	0.17	0.11	0.054	0.022	2.4kg
AWAU-YCV180-H13							5.0kg

Refrigerant charging amount when out of factory excludes that in the distributing pipe.

Note:

- To prevent the different oil into the pipe, please use the special tool for R410A, especially for gauge manifold and charging hose.
- Mark the refrigerant type in different colour on the tank. R410A is pink.
- Must not use the charging cylinder, because the R410A will change when transferring to the cylinder.
- When charging refrigerant, the refrigerant should be taken out from the tank as liquid state.
- Mark the counted refrigerant volume due to the distributing pipe length on the label.

Fix the refrigerant pipe

- In operation, the pipe will vibrate and expand or shrink. If not being fixed, the refrigerant will focus on one part to cause the broken pipe.
- To prevent the central stress, fix the pipe for every 2-3m.

Heat insulation

- Gas pipe and liquid pipe should be heat insulated separately.
- The material for gas pipe should endure the high temperature over 120degree. That for liquid pipe should be over 70degree.
- The material thickness should be over 10mm, when ambient temp. is 30degree, and the relative humidity is over 80%, the material thickness should be over 15mm.
- he material should cling the pipe closely without gap, then be wrapped with adhesive tape. The connection wire can not be put together with the heat insulation material and should be far at least 20cm.

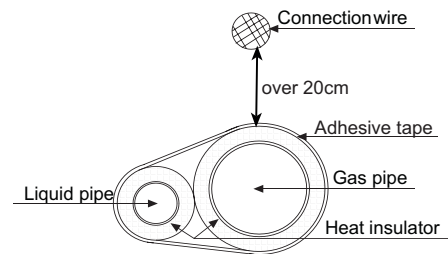

9.9 Requestment of copper pipe specs and thickness

Exterior diameter(mm)	Pipe thickness(mm)	Remarks
6.35	more than 0.8	coil pipe
9.52	more than 0.8	
12.7	more than 1.0	
15.88	more than 1.0	
19.05	more than 1.0(straight pipe)	more than 1.0 (coil pipe)
22.22	more than 1.0	straight pipe
25.4	more than 1.0	
28.58	more than 1.0	
31.8	more than 1.1	
34.9	more than 1.3	
38.1	more than 1.4	
41.8	more than 1.5	

9.10 Utilized tool comparison for R22 and R410A

TOOL	PURPOSE	R22	R410A	REASON
knife	cut the pipe	○	○	
expander	enlarge the pipe	○	×	for R410A, must enlarge the projecting pipe
spanner	fasten the flare nut	○	×	standard torque of 1/2, 5/8 pipe is larger
flare tool	flare the pipe	○	○	
pipe bender	bend the pipe	○	○	
pressure gauge	used in leakage test	○	×	leakage test pressure is higher
welding torch	brazing the pipe	○	○	
gauge manifold	evacuation device	○	×	different pressure from R22: max.: HP5.3Mpa min.:3.5Mpa
charging hose	charging refrigerant	○	×	
vacuum pump with one-way stop valve	evacuation device	○	×	must ensure oil in vacuum pump an not flow into the unit when pump stops
charging cylinder	charging refrigerant	○	×	R410A can not be charged as gas state
electronic charging scale	charging refrigerant	○	○	
leakage detector	leakage detecting	○	×	can not use freon detector (CFCs or HCFCs), R410A excludes Cl. Use the hydrogen detector (or R134a detector)

Note: The pipes of R410A connection with the same diameter can not be welded with the flared joints. You must expand the diameter of pipe joint, then weld the connecting pipe.

9.11.1 Before trial running

Make sure the following works have been finished according to the installation manual.

- a. Piping work
- b. Wiring work
- c. Leakage check
- d. Evacuate work
- e. Additional refrigerant charging
- f. Also check if the indoor works have been finished

Note: Recommend that the unit has been electrified for 12 hours for compressor protection. When the unit starts up again, the indoor will start up 5 minutes later after compressor starts up.

9.11.2 Trial running

After checking the above works are finished, operate the unit normally and check the following items:

- a. Make sure the indoor and the outdoor are operating normally;
- b. Operate indoor unit one by one and make sure the corresponding outdoor unit is also running well;
- c. Check if the proper temperature air is blowing out from indoor unit;
- d. Check if the fan speed can be adjusted properly by the controller

Note:

1. Heating and cooling mode can be operated under the correct temperature range.
2. If a knocking noise can be heard from the compressor, stop the unit immediately and then energize the crankcase heater to get enough long time before restarting the unit.
3. Once stopping, the compressor will not run right now only after the unit has stopped for 3 minutes, which can protect the compressor.
4. In the quiet running at night mode, the outdoor fan will be at low speed. But this is not a malfunction.

9.11.3 Check after trial running

Perform the following inspections after the trial running is finished:

1. Record the field setting
2. Record the installation data: pipe length, height difference, charge amount, etc..

10. Electric installation

Warning :In European Market :local 3 phase isolator (power switch) must be fitted locally to the unit (Legal requirement for EU).

For other area, pls. comply with local regulation requirement.

Electric wiring should be executed by the specialized well-trained person.

Warnings:

- A. Do not take the other wire except for copper wire as the power cable.
- B. All indoor/outdoor units must be connected with the earthing wire of power cable. The earthing wire can not be connected onto the earthing wire of coal gas pipe, water pipe, lightning rod, or telephone. Or the electric shock or fire will occur.
- C. Must install the leakage breaker and the over current breaker, or electric shock will occur.
- D. Before finishing electric installation, do not electrify the unit.
- E. Indoor and outdoor use their individual power source. All indoors use one power source.
- F. The communication wire and the power cable must be individual and can not use one multi-core cable, or the communication wire will be interfered to cause abnormal.

Note: When one wired controller controls multiple indoors, the connected indoor units must use the common phase of power source, or the communication will be abnormal. For example, the power source is L1,L2,L3,and N, all the indoor units must use L1/N or L2/N or L3/N.

1. Wiring system

(1) Power wiring figure

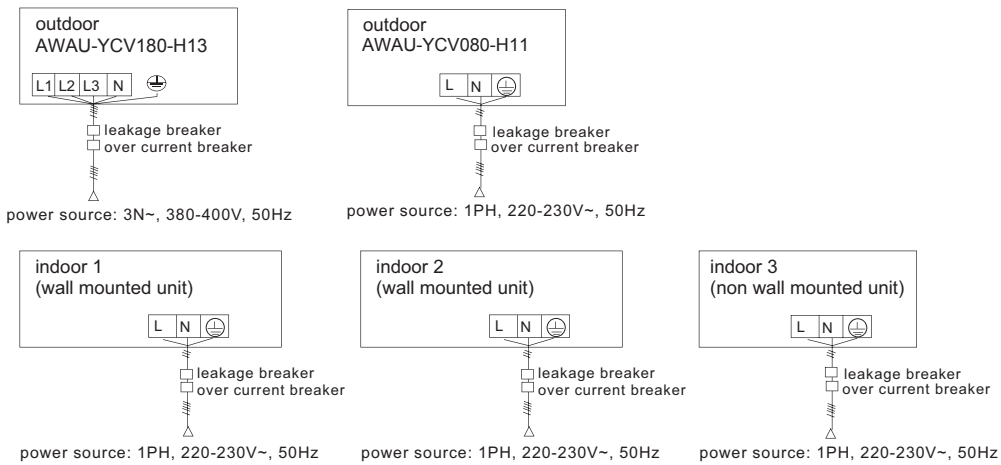

(2) Communication wiring figure

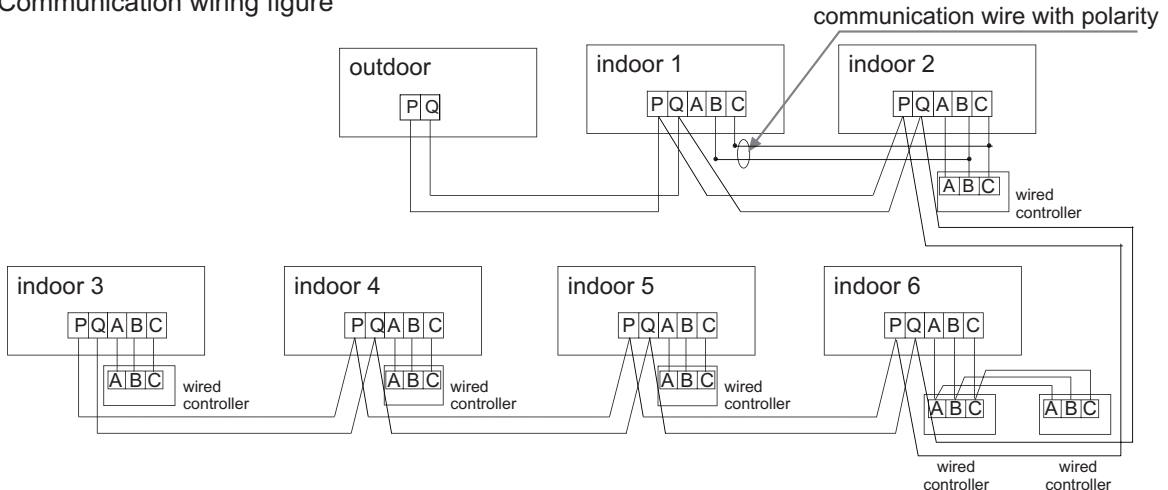

The outdoor and all indoor units are in parallel through 2 non-polar wires.

Three wiring methods between wired controller and indoor unit:

A. 1 to multi (group control): one wired controller controls 2~16 indoors, as shown in above figure, indoor 1~indoor 2: indoor 2 is wired control master unit, the others are wired control slave units. Wired controller and the master indoor (directly connected to wired controller) is connected by 3 polar wires; the other indoors and the master indoors are connected by 2 polar wires.

B. 1 to 1 (one wired controller controls one indoor): as shown in above figure, indoor 3~ indoor 4, indoor and wired controller are connected by 3 polar wires.

C. 2 to 1 (two wired controller controls one indoor): as shown in above figure, indoor 6. Either of wired controllers can be set as master wired controller, and the other is slave wired controller. Master/slave wired controller, and master/indoor are connected by 3 polar wires.

When indoor is controlled by remote controller, refer to the "wired control master unit/wired control slave unit/remote control unit table".A, B, C on signal terminal block need not wires and not connect the wired controller.

2. Specs for power cable and communication wire

(1) Outdoor power source and power cable

item model		power source	power cable section (mm ²)	circuit breaker (A)	rated current of residual current circuit breaker(A) leakage current (mA) response time(s)	earthing wire	
						section (mm ²)	screw
individual power	YCV080-H11	1PH~, 220-230V, 50Hz	4	40	40A 30mA below 0.1S	3.5	M5
	YCV180-H13	3N~, 380-400V, 50Hz	4	60	40A 30mA below 0.1S	3.5	M5

- Power cable must be fixed firmly.
- Each outdoor must be earthed well.
- When power cable exceeds the range, thicken it appropriately.

(2) Indoor power source, communication wire between indoor and outdoor, among indoors

indoor total current (A)	power cable section (mm ²)	wire length (m)	rated current of overcurrent breaker(A)	rated current of residual current circuit breaker(A) leakage current (mA) response time(s)	communication wire section	
					outdoor/indoor (mm ²)	indoor/indoor (mm ²)
< 10	2	23	20	20A, 30mA, below 0.1s	2-core * (0.75-2.0mm ²) shielded wire	
≥ 10 and < 15	3.5	24	30	30A, 30mA, below 0.1s		
≥ 15 and < 22	5.5	27	40	40A, 30mA, below 0.1s		
≥ 22 and < 27	10	42	50	50A, 30mA, below 0.1s		

- Power cable and communication wire must be fixed firmly.
- Each indoor must be earthed well.
- When power cable exceeds the range, thicken it appropriately.
- Shielded layer of communication wires must be connected together and be earthed at single point.
- Communication wire total length cannot exceed 1000m.

(3) Communication wire for wired controller

wire length(m)	wire spec	wire length(m)	wire spec
< 100	0.3mm ² × (3-core) shielded wire	*300 and <400	1.25mm ² × (3-core) shielded wire
≥ 100 and <200	0.5mm ² × (3-core) shielded wire	*400 and <600	2mm ² × (3-core) shielded wire
≥ 200 and <300	0.75mm ² × (3-core) shielded wire		

- a. Shielded layer of communication wire must be earthed at one end.
- b. The total length cannot exceed 600m.

(4) Control type and the switchover

- a) Indoor unit can be controlled by wired controller or remote controller.
- b) When installation, the installer must set the unit due to the control type and wiring type.

Switchover between wired control master/slave unit /remote control unit, set when installation:

control type socket /dip switch	wired control master unit	wired control slave unit	remote control
CN23	short connected	disconnected	disconnected
CN30	short connected	short connected	disconnected
CN21	blank	blank	to remote receiver
SW08-[6]	ON	ON	OFF
signal terminal block	A,B,C to wired controller	B,C to wired controller	A,B,C not to wired controller

Note:

1. In the above figure, the state in the frame is set when out of factory.
2. The indoor controlled by master/slave wired controller and the indoor controlled by individual wired controller are all wired controlled master indoor.
3. The remote receiver is equipped with a wire which can be inserted in CN21.

3. Note: For the indoor unit controlled by wired controller, if indoor unit is with the remote receiver, MUST pull out the white wire from the remote receiver connector.

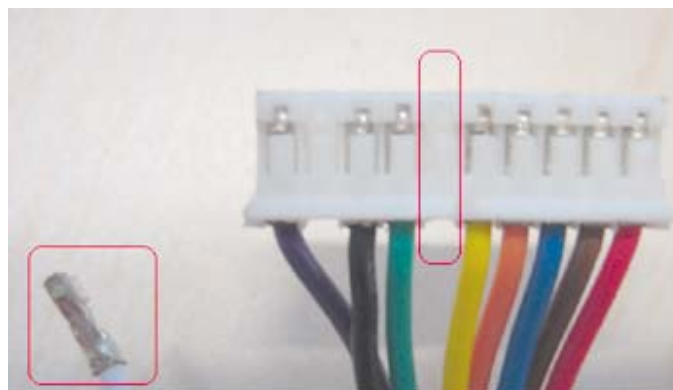

4. Note: Correct procedure to shut off the unit: switch off the unit by the controller, then cut off the power source. FORBIDDEN to cut off the power directly!
5. All the indoor EEVs are at open state which are set out of factory.

3. Indoor central control address setting method

No.	setting type	setting method	remarks
1	Set by hand	1.SW02 on indoor PCB is ON (upper); 2. The detailed position refers to the below table.	set on field
2	Set by wired controller	1. SW02 on indoor PCB is OFF(down), set when out of factory. 2. Press "FILTER" on wired controller continuously for 10 seconds into central control setting mode, and select the indoor central control address by "TEMP+/-". 3. Temp. area indicates: system address+XX, press "TEMP+/-", the unit number will change "00~3F" (00 is No.1, 3F is No.64), and the initialization is 00. 4. After selecting the number, press "SET" to save it; if pressing other buttons or no pressing within 15 seconds, it will quit automatically and keep the former setting.	set on field

Indoor central control address table (set by hand)

SW02								central control address	SW02								central control address	SW02								central control address
1	2	3	4	5	6	7	8	1	1	2	3	4	5	6	7	8	1	1	2	3	4	5	6	7	8	1
1	0	0	0	0	0	0	0	1	1	0	0	1	0	1	1	0	23	1	0	1	0	1	0	1	1	44
1	0	0	0	0	0	0	1	2	1	0	0	1	0	1	1	1	24	1	0	1	0	1	1	0	0	45
1	0	0	0	0	0	1	0	3	1	0	0	1	1	0	0	0	25	1	0	1	0	1	1	0	1	46
1	0	0	0	0	0	1	1	4	1	0	0	1	1	0	0	1	26	1	0	1	0	1	1	1	0	47
1	0	0	0	0	1	0	0	5	1	0	0	1	1	0	1	0	27	1	0	1	0	1	1	1	1	48
1	0	0	0	0	1	0	1		1	0	0	1	1	0	1	1	28	1	0	1	1	0	0	0	0	49
1	0	0	0	0	1	1	0	7	1	0	0	1	1	1	0	0	29	1	0	1	1	0	0	0	1	50
1	0	0	0	0	1	1	1	8	1	0	0	1	1	1	0	1	30	1	0	1	1	0	0	1	0	51
1	0	0	0	1	0	0	0	9	1	0	0	1	1	1	1	0	31	1	0	1	1	0	0	1	1	52
1	0	0	0	1	0	0	1	10	1	0	0	1	1	1	1	1	32	1	0	1	1	0	1	0	0	53
1	0	0	0	1	0	1	0	11	1	0	1	0	0	0	0	0	33	1	0	1	1	0	1	0	1	54
1	0	0	0	1	0	1	1	12	1	0	1	0	0	0	0	1	34	1	0	1	1	0	1	1	0	55
1	0	0	0	1	1	0	0	13	1	0	1	0	0	0	1	0	35	1	0	1	1	0	1	1	1	56
1	0	0	0	1	1	0	1	14	1	0	1	0	0	0	1	1	36	1	0	1	1	1	0	0	0	57
1	0	0	0	1	1	1	0	15	1	0	1	0	0	1	0	0	37	1	0	1	1	1	0	0	1	58
1	0	0	0	1	1	1	1	16	1	0	1	0	0	1	0	1	38	1	0	1	1	1	0	1	0	59
1	0	0	1	0	0	0	0	17	1	0	1	0	0	1	1	0	39	1	0	1	1	1	0	1	1	60
1	0	0	1	0	0	0	1	18	1	0	1	0	0	1	1	1	40	1	0	1	1	1	1	0	0	61
1	0	0	1	0	0	1	0	19	1	0	1	0	1	0	0	0	41	1	0	1	1	1	1	0	1	62
1	0	0	1	0	0	1	1	20	1	0	1	0	1	0	0	1	42	1	0	1	1	1	1	1	0	63
1	0	0	1	0	1	0	0	21	1	0	1	0	1	0	1	0	43	1	0	1	1	1	1	1	1	64
1	0	0	1	0	1	0	1	22																		

Communication address between indoor and outdoor setting by hand:

1st, 2nd bit of SW03 are ON, the latter six bits can confirm the communication address, the address setting refers to the "central control address setting table". For example, the communication address is 8, the dip switch of SW03 is 11000111.

4. Indoor control type selection

indoor PCB	wired control master unit	wired control slave unit	remote control	remarks
CN23	short connected	disconnected	disconnected	1.The communication address between master/slave wired controller and the outdoor is different. 2. If central control is necessary, all indoor central control addresses in one group are identical, while the indoor address in different groups is different too.
CN30	short connected	short connected	disconnected	
CN21	blank	blank	to remote receiver	
SW08-[6]	ON	ON	OFF	
SW01 [1]-[4]	"0"	1~15 (different dialing setting on SW01 for the slave units in one group)	"0"	
signal terminal block	A,B,C to wired controller	B,C to wired controller	A,B,C not to wired controller	

Note: In the above figure, the state in the frame is set when out of factory.

5.Setting state and the function definition of PCB and wired controller when out of factory

item	parts	state	function	
indoor PCB	dip switch	SW01 [1]-[4]	at "0" 1. When one wired controller controls one indoor, multiple wired controllers control one indoor, or indoor is controlled by remote controller, the switch needs not be changed. 2. When one wired controller controls multiple indoors, the switch of master unit is 0, while the slave units are at the position from 1 to 15.	
		SW02	all at "OFF" 1. When setting central controlled address by wired controller, it need not change. 2. When setting central controlled address by hand, refers to the setting table 1.	
		SW03	all at "OFF" When setting communication address between indoor and outdoor automatically, it needs not change. When setting by hand or by wired controller, refers to the setting table2.	
	jumper	CN23	connected	When being controlled by wired controller, it is connected; when being controlled by remote controller, it is disconnected.
		CN25	disconnected	tested in the factory
		CN26	disconnected	output in series, connected to testing device.
		CN27	disconnected	connected after being powered on, indoor EEV opens 2 minutes fully.
		CN28	disconnected	connected after being powered on, indoor in time shorting function

item	parts	state	function			
indoor PCB	jumper	CN29	disconnected connected after being powered on, indoor EEV closes 2 minutes fully.			
		CN30	connected When being controlled by wired controller, it is connected; when being controlled by remote controller, it is disconnected.			
		CN31	disconnected indoor trial operation			
		CN35	disconnected for wiring the program			
		CN36	disconnected for wiring the program			
	dip switch	SW07 -[5]	ON	Air inlet temp. TA compensation value		
				SW07-[5]	SW07-[4]	TA correction value
				OFF	OFF	12*
		SW07 -[4]	ON	OFF	ON	8*
				ON	OFF	4*
				ON	ON	0*(out of factory)
	SW08 -[1]	ON	ON: change high/mid/low fan speed; OFF: the fixed fan speed(for duct type).			
	SW08 -[6]	ON	ON: be controlled by wired controller; OFF: be controlled by remote controller			
	indicator	LED1	red	indicator of communication with wired controller. Shows indoor sending signal to wired controller		
		LED2	green	indicator of communication with wired controller. Shows indoor receiving signal from wired controller		
				LED1, LED2 used in combination. If communication between wired controller and indoor is normal, LED1, LED2 will flash regularly. If there is slave wired controller, FQY of LED1 of slave controller will be low.		
		LED3	red	indicator of communication with outdoor. Shows indoor sending signal to outdoor		
		LED4	green	indicator of communication with outdoor. Shows indoor receiving signal to outdoor		
				LED3, LED4 used in combination. If communication between indoor and outdoor is normal, LED1, LED2 will flash regularly. FQY of red LED is lower than that of green LED.		
	LED5	failure	in normal state, it is OFF. Confirm the failure due to the indicator flashes times			
	LED6	yellow	in normal state, it is OFF. Indicate when EEV is open/close fully.			

Wired controller:

new	old	selection item	state	function description
D9	J02	changeover of controller type	0	set as simple controller
			1	set as standard controller
D12	J06	selection of room temp. sensor	0	use room temp. sensor on wired controller
			1	not use room temp. sensor on wired controller
D15	J07	auto restart	0	without auto restart
			1	with auto restart
D14	J03	selection of room temp. display	0	display room temp.
			1	not display room temp.

new	old	selection item	state	function description
SW[1]	SW20-[1]	changeover of master/slave controller	ON	set as slave controller
			OFF	set as master controller
SW[2]	SW20-[2]	°C or °F	ON	°F
			OFF	°C
JP8	D1	shorten time function	0	indoor shorting time
			1	without shorten time
JP7	D2	compulsory defrost	0	send to compulsory defrost signal
			1	normal operation

Note: 1. D1, D2 are the diode, if the two terminals are disconnected, the state is "1"; if the two terminals are connected with a jumper, the state is "0".

2. Only when two controllers control one indoor unit, one of wired controllers can be set as slave controller, and set SW20-[1] as ON, the others keep the state when out of factory, set SW20-[1] as OFF.

3. The old type: there are resistors of J03 and J06 beside the dip switch.

6. Method of installation and trial run

1. Function explanation of switch SW01, SW02. We can know the number of some parameters by using testing device, but must be connected to the testing device.

which is not in the control board. The testing device must be bought from the manufacturer.

SW01	SW02	Display of numeral pipe light with seven segments
0	0	Checking code of outdoor unit Display: --- When no checking code When total capacity of indoor units exceeds 130% of rated capacity of outdoor unit, display: F F F
	1	Operation mode of outdoor units: Cooling: -C, Heating: -H, Defrosting: -J
	2	No used
	4	Target of operating frequency of compressor (Decimal number):
	5	Actual operating frequency of compressor (Decimal number):
	6	Indoor units connected (Decimal number):
	7-15	No used
1	0	Sensor TD Air Discharge value (*)(decimal number):
	1	Sensor TA Environment temp. value (*)(decimal number):
	2	Sensor TS Air suction value (*) (decimal number):
	3	Sensor TE Defrost value (*)(decimal number):
	4	Sensor TC middle part of Condenser value (*) (decimal number):
	5	No used
	6	No used
	7	Opening of outdoor unit PMV (decimal number):
	8	Magnet valve SV2: ON:1 OFF: 0
	9	Magnet valve SV1: ON:1 OFF: 0
	10	Current value of compressor when operating(decimal number)
	11	Blower fan mode of outdoor Low speed: -1 Medium speed:-2 High speed:-3
	12	Total current value of outdoor when operating(decimal number)
	13	On position of 4-way valve display: ON: 1, OFF: 0
14	No used	
2	0-11	No used
3	0-8	No used
4	0-15	No used
5	0-15	Indoor unit capacity (Pi): CODE : 0.8 denote 0.8(pi) ; 1 denote 1(pi) ; 1.2 denote 1.2(pi) ; 1.5 denote 1.5(pi) ; 2 denote 2(pi) ; 2.5 denote 2.5(pi) ; 3 denote 3(pi) ; 4 denote 4(pi) ;

SW01	SW02	Display of numeral pipe light with seven segments
6	0-15	Required capacity of indoor unit (Decimal number): indoor S-CODE
7	0-15	Opening of indoor unit PMV (Decimal number):
8	0-15	No used
9	1-16	Sensor temperature (*) of indoor unit TA (Decimal number): -26.0~67.0*
10	1-16	Sensor temperature (*) of indoor unit TC1 (Decimal number): -26.0~100.0*
11	1-16	Sensor temperature (*) of indoor unit TC2 (Decimal number): -26.0~100.0*
12	1-16	No used
13	1-16	No used

2. START-STOP-UP-DOWN functions on outdoor PCB

Press "START" FOR 5 seconds to enter the setting mode of up/down frequency. By pressing "UP" and "DOWN" increase or decrease frequency. Press "STOP" for 5 seconds to quit the up/down frequency mode, then enter the normal frequency control. In the course, the frequency decreasing will be limited by current, discharging, or suction.

Besides, you can realize the compulsory cooling or heating by there buttons:

1) Press "START",in the same time, press DOWN for 8 seconds to enter or quit compulsory cooling operation.

1: fixed standard open angle 480

2: fixed running frequency 50HZ

3: fixed outdoor fan motor at high speed

2) Press "STOP", in the same time, press UP for 8 seconds to enter or quit compulsory heating operation.

1: fixed standard open angle 120

2: fixed running frequency 50HZ

3: fixed outdoor fan motor at high speed

11. Trial operation and the performance

3-minute delay function

If starting up the unit after being powered off, the compressor will run about 3 minutes later against being damaged.

Cooling/heating operation

Indoor units can be controlled individually, but cannot run in cool and heat mode at the same time. If the cool mode and the heat mode are existing simultaneously, the unit set latter will be standby, and the unit set earlier will run normally. If the A/C manager sets the unit at cooling or heating mode fixedly, the unit can not run at the other modes.

Defrosting in heating mode

In heating mode, outdoor defrosting will affect the heating efficiency. The unit will defrost for about 2~10 minutes automatically, at this time, the condensate will flow from outdoor, also in defrosting, the vapour will appear at outdoor, which is normal. Indoor motor will run at low speed or stop, and outdoor motor will stop.

The unit operation condition

To use the unit properly, please operate the unit under the allowed condition range.

If operating beyond the range, the protection device will act.

The relative humidity should be lower than 80%. If the unit runs at the humidity over 80% for a long period, the dew on the unit will drop down and the vapour will be blowed from air outlet.

Protection device (such as high pressure switch)

High pressure switch is the device which can stop the unit automatically when the unit runs abnormally.

When the high pressure switch acts, the cooling/heating mode will stop but the running LED on wired controller will be light still. The wired controller will display failure code.

When the following cases occur, the protection device will act:

In cooling mode, air outlet and air inlet of outdoor are clogged.

In heating mode, indoor filter is stucked with duct; indoor air outlet is clogged.

When protection device acts, please cut off the power source and re-start up after eliminating the trouble.

When power is failure

When power is failure in running, all the operations will stop.

After being electrified again, if with re-satrt up function, the unit can resume to the state before power off automatically; if without re-satrt up function, the unti needs to be switched on again.

When abnormal occurs in running because of the thunder, the lightning, the interference of car or radio, etc, please cut off the power source, after eliminating the failure, press "ON/OFF" button to start up the unit.

Heating capacity

The heating mode adopts the heat pump type that absorbs outdoor heat energy and releases into indoor. So if outdoor temperature goes down, the heating capacity will decrease.

1. System marks

On the condition that multi MRV II systems are installed, in order to confirm the relationship between outdoor and indoor, please make marks on outdoor electric control box cover to indicate the connected indoor unit. As the below figure:

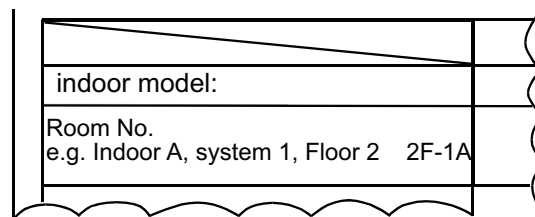

2. Trial operation sequence

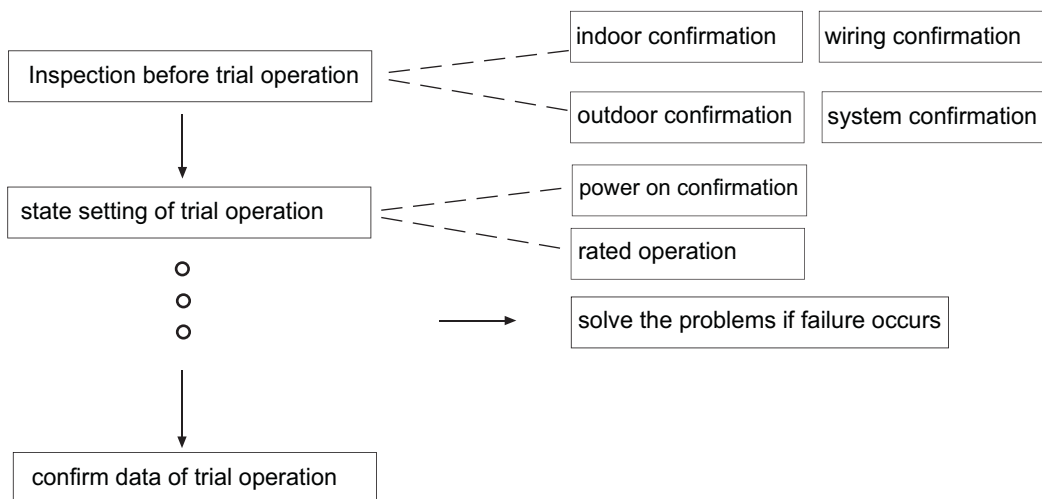

3. Inspection before trial operation

Before inspection, confirm the state of indoor and outdoor to avoid the trial failure because of the incorrect installation.

3.1 Indoor unit confirmation

No.	inspection items	results
1	If indoor unit is in good condition, and if the electric box position is in accordance with the state when out of factory, also if it is fixed firmly.	
2	If indoor wiring is correct. If the connecting terminal of the fan motor, swing motor and water pump is connected well. If the sensor is in good condition and it is at the proper place.	
3	If the dip switch of indoor unit is set correctly. If the indoor address, central controller address, wired controller address and its other selection are correct.	
4	If the wire sequence of wired controller is correct.	
5	Before being electrified, measure the resistors among live wire, neutral wire and earthing point on the terminal block with the 500V ohmmeter. The resistor must be over 1 M Ohm.	

3.2 Outdoor unit confirmation

No.	inspection items	results
1	If outdoor unit is in good condition, and if the electric box is fixed firmly.	
2	If outdoor wiring is correct. If the wires are broken.	
3	If the dip switch of outdoor unit is set correctly. If the outdoor address is correct. The master unit No. must be No.1, and the other units can be No. 2, No.3. If there are multiple outdoors, before being electrified, the master unit SW4-5 is set as "searching outdoor".	

3.3 Wiring confirmation

No.	inspection items	results
1	If outdoor power cable is fixed at correct position. And if the power cable is in compliance with the requirement.	
2	If indoor power cable is fixed at correct position. And if the power cable is in compliance with the requirement.	
3	Check the indoor power wiring to prevent that one of indoors has already powered down, all the other indoors and outdoors in one system are normally running. Indoors in one system should adopt one power supply.	
4	If the communication wire between outdoors complies with requirement, and A, B, C must be corresponding, or the PCB will be damaged.	
5	If the communication wire between indoor and outdoor complies with requirement, and the communication wires do not care the phase sequence, but the shielded wire is needed. The shielded layer among indoors must be continuous. The communication wire of the whole system must be earthed at the farthest shielded wires of indoor and outdoor.	
6	If the communication wire between indoor and wired controller complies with requirement, and A, B, C must be corresponding, or the wired controller will be abnormal.	
7	The distance between high voltage and low voltage of the power cable and the communication wire must be over 50mm. Or communication failure will occur.	

3.4 System confirmation

liquid pipe diameter	standard additional charging amount(kg/m)	total length of liquid pipe (mm)	every liquid pipe additional charging amount(kg)
∅ 6.35	6.35	=	
∅ 9.52	9.52	=	
∅ 12.7	12.7	=	
∅ 15.88	15.88	=	
∅ 19.05	19.05	=	
∅ 22.22	22.22	=	
		total additional charging amount	

Note: Check if outdoor stop valve has been open fully. When there is only master unit, please confirm if the oil pipe stop valve has been close fully.

4. State setting of trial operation

4.1 Confirm being electrified

Indoor and outdoor are electrified respectively and then check as the following table:

No.	inspection items	results
1	If outdoor PCB is electrified; if the communication indicator flashes.	
2	If indoor communication indicator flashes.	
3	Check the indoor running parameters are correct after outdoor is connected the testing board and the testing software, such as the sensor characteristic, the EEV open angle, etc.	

5. Trial operation

Generally, confirm all the indoors one by one. Please set the other indoors at STOP state.

(1) Main power supply and preliminary confirmation

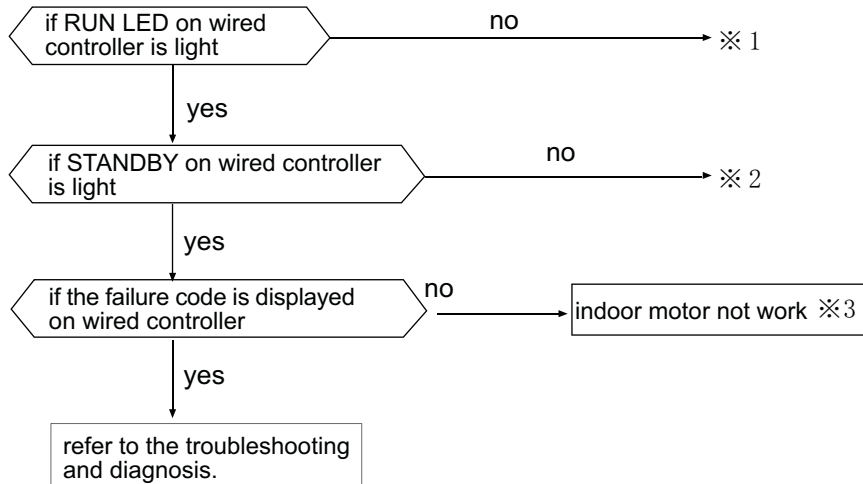

(2) Motor operation confirmation

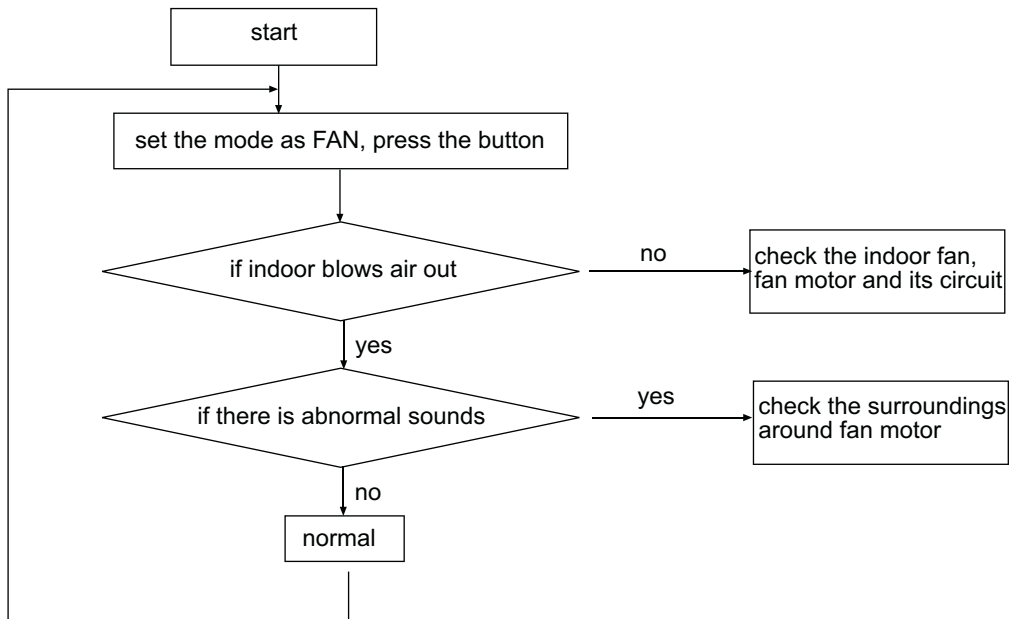

(3) Cooling operation confirmation

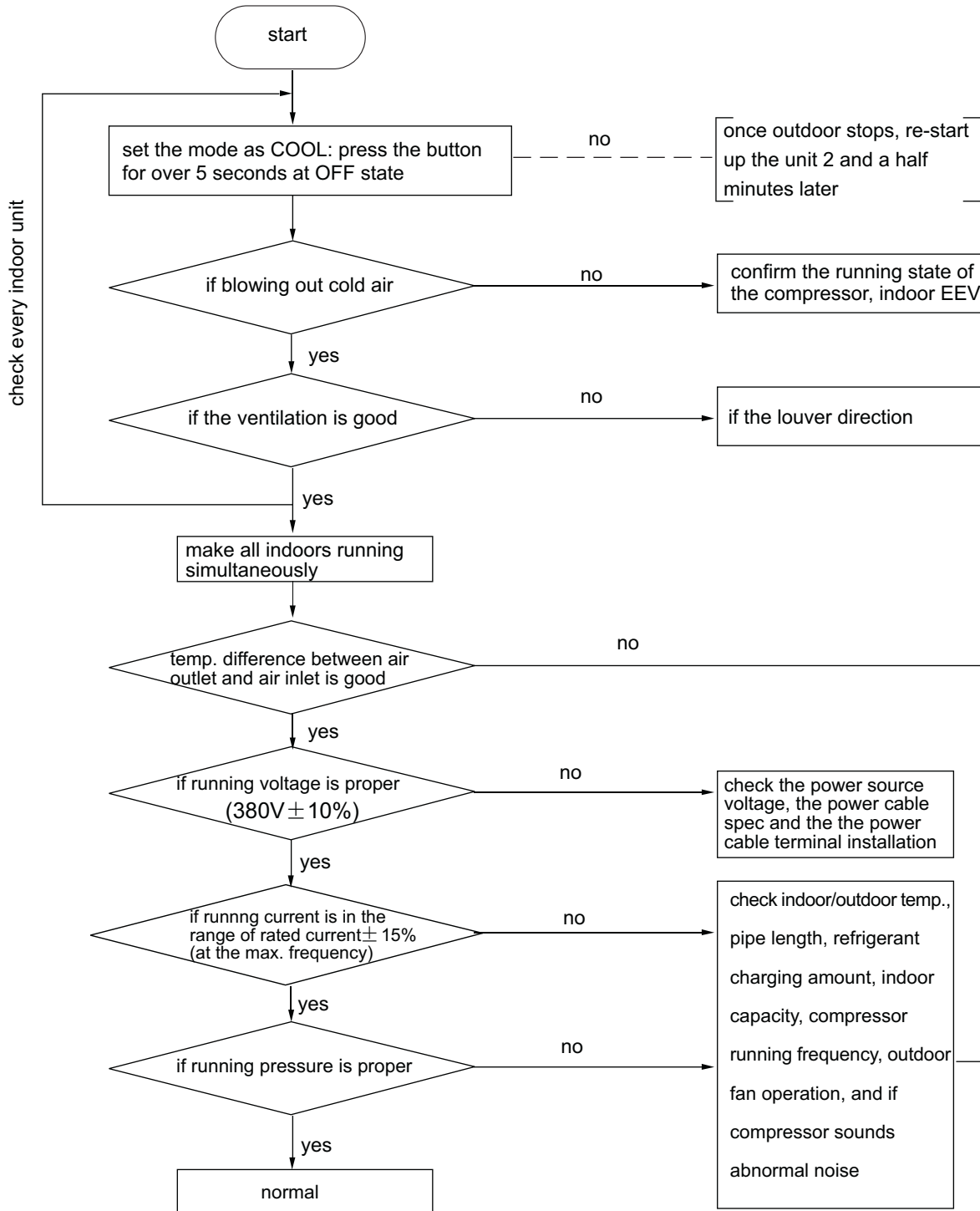

(4) Heating operation confirmation

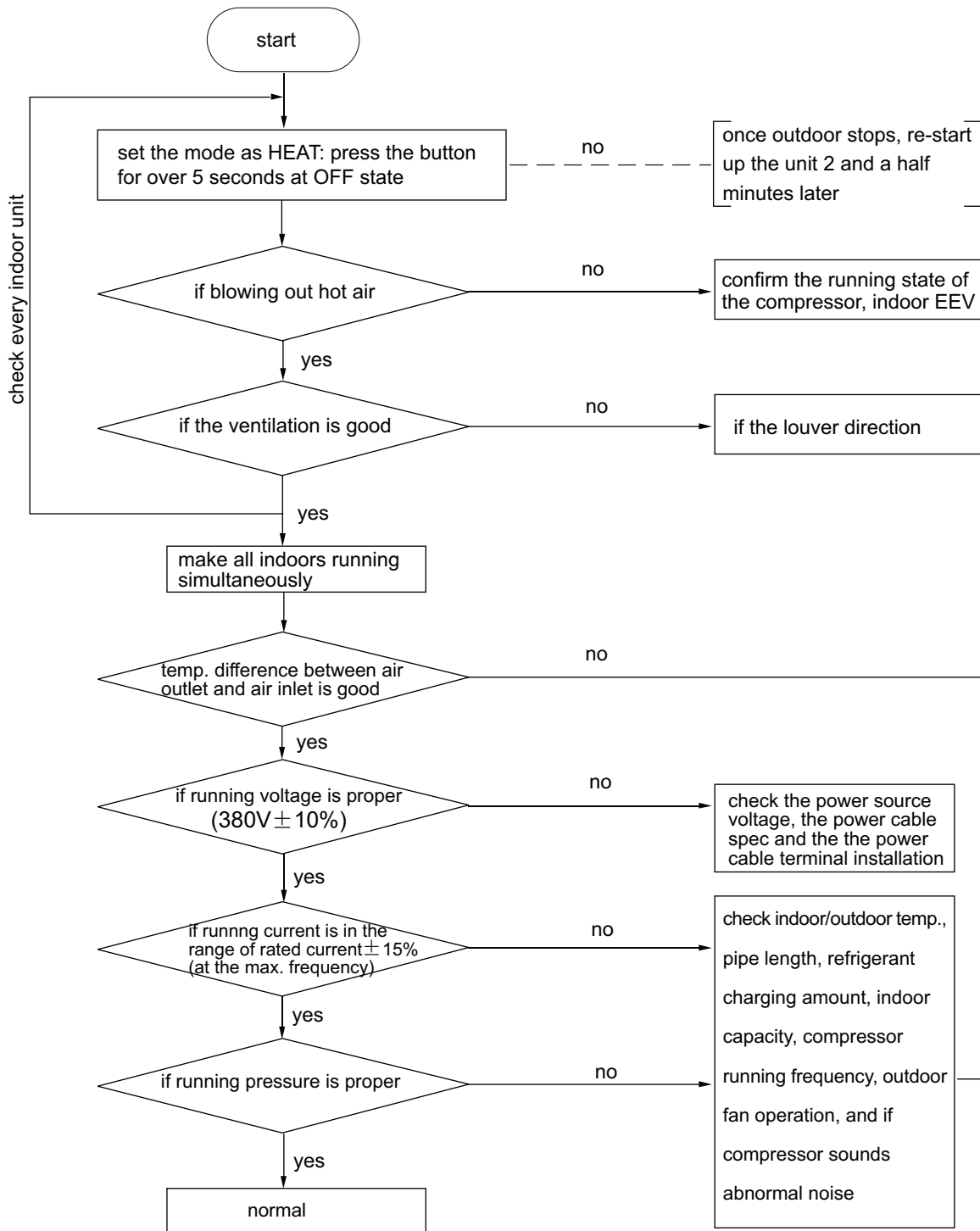

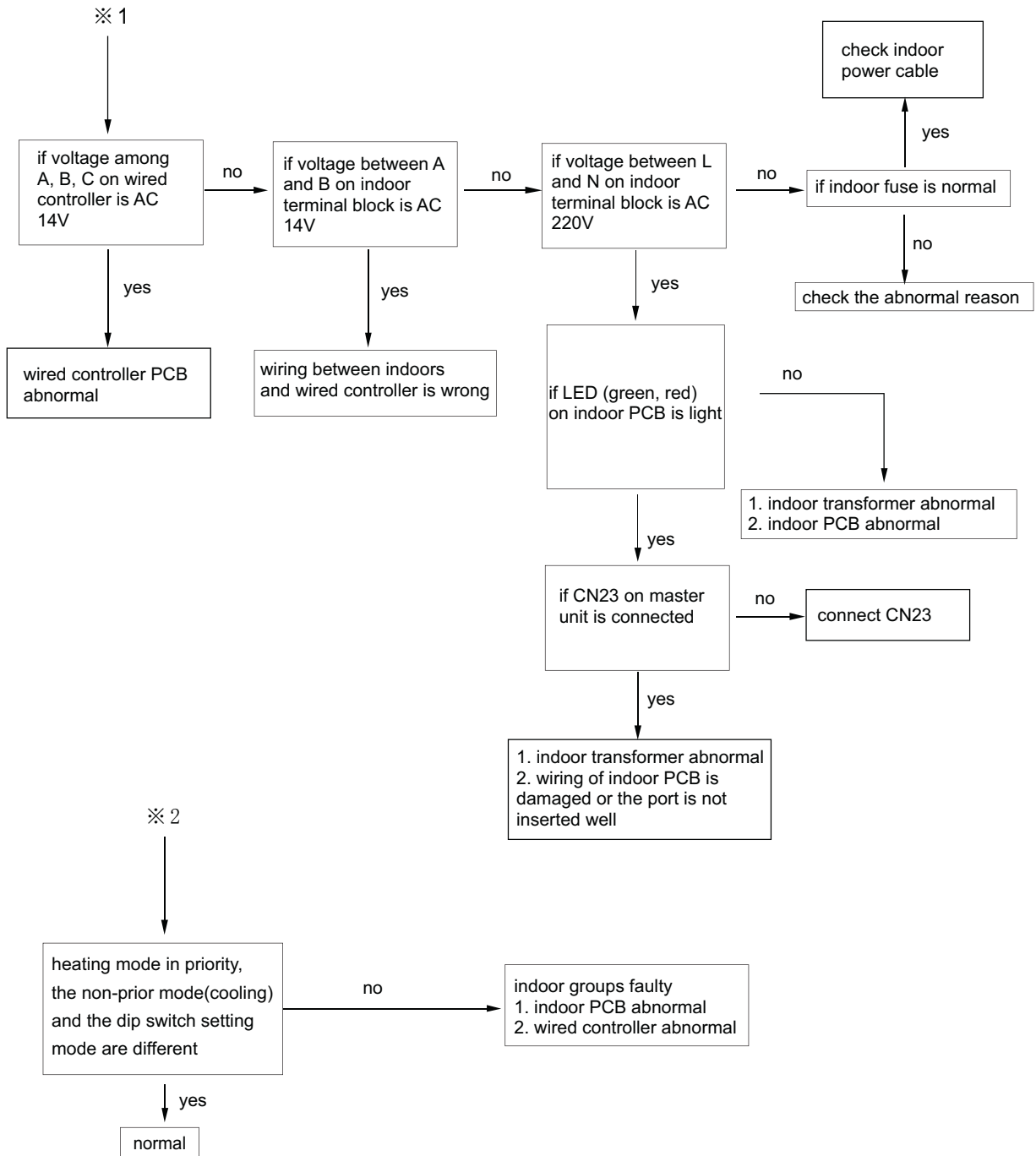

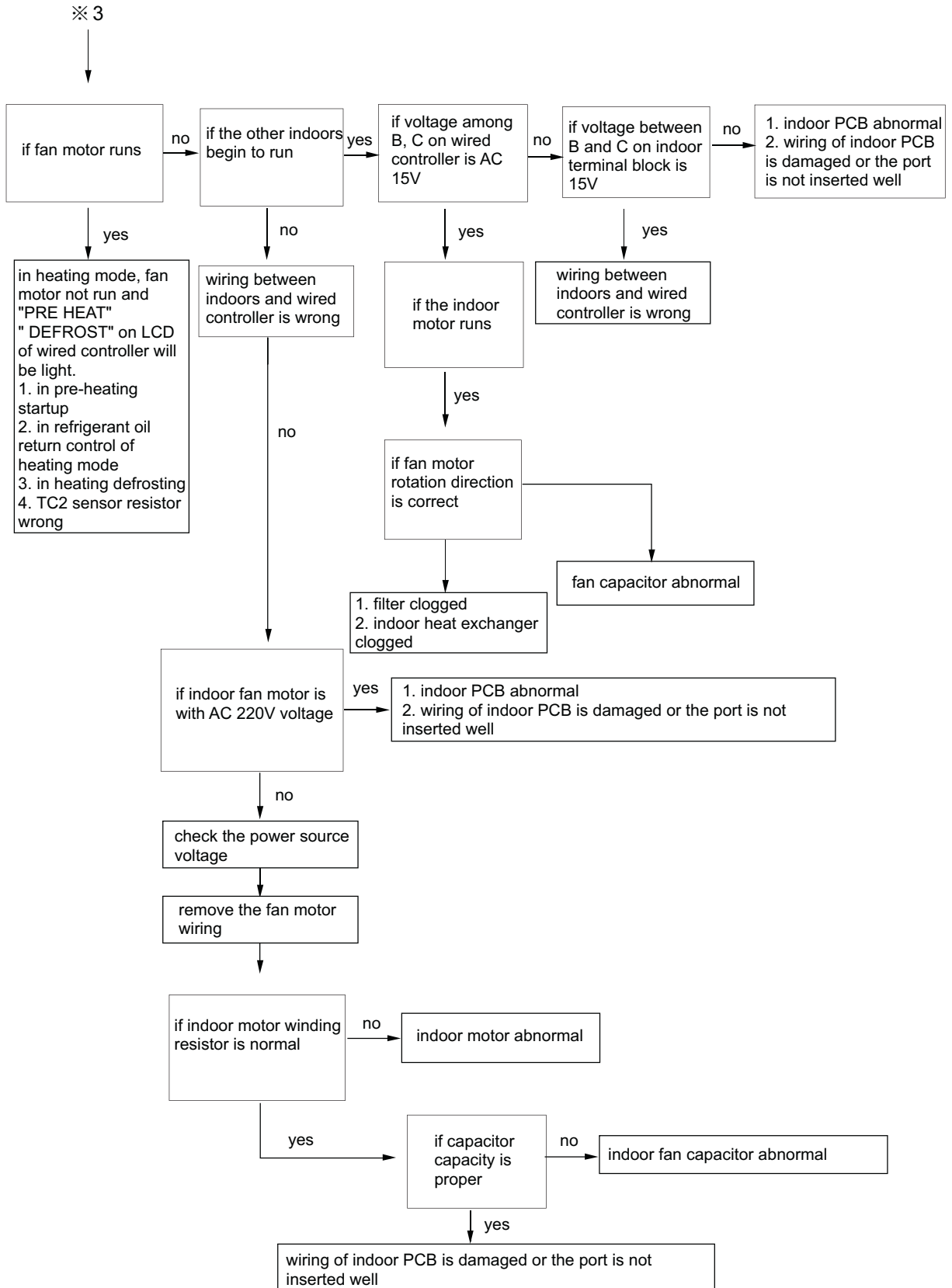

Note 1: Temp. difference between air inlet and air outlet Standard

A. In cooling mode, after running for at least 30 minutes, it is normal that the temp. difference between air inlet and air outlet is over 10°C, (at max. frequency)

B. In heating mode, after running for at least 30 minutes, it is normal that the temp. difference between air inlet and air outlet is over 14°C, (at max. frequency).

Note 2: Running current standard

It is normal that the running current is in the range of rated current $\pm 15\%$ (at max. frequency) . The current will be different for the below condition:

if more than the rated current: high indoor/outdoor temp. ; outdoor bad ventilation (cooling mode), indoor bad ventilation (heating mode).

if lower than rated current: low indoor/outdoor temp.; refrigerant leakage (lack of refrigerant).

Note 3: Running pressure standard

cooling (at max. frequency)	high pressure 2.0~3.5MPa	indoor 18~32°C
	low pressure 0.6~1.0MPa	outdoor 25~35°C
heating (at max. frequency)	high pressure 2.2~2.8MPa	indoor 15~25°C
	low pressure 0.3~0.8MPa	outdoor 5~10°C

The above value is measured after running for 15 minutes (ambient temp. is DB°C)

High/low pressure changing trend due to the running condition:

Cooling/heating:

indoor temp. goes up---high/low pressure goes up

indoor temp. goes down---high/low pressure goes down

outdoor temp. goes up---high/low pressure goes up

outdoor temp. goes down---high/low pressure goes down

12. Maintenance

Outdoor failure code list

failure code	failure	description
1	defrosting temp. sensor Te failure	the sensor is in open circuit or short circuit for 30 seconds, resumable and keep well if no alarm within 3 minutes
2	ambient temp. sensor Ta failure	the sensor is in open circuit or short circuit for 30 seconds, resumable and keep well if no alarm within 3 minutes
3	suction temp. sensor Ts failure	the sensor is in open circuit or short circuit for 30 seconds, resumable and keep well if no alarm within 3 minutes
4	discharging temp. sensor Td failure	the sensor is in open circuit or short circuit for 30 seconds, resumable and keep well if no alarm within 3 minutes (ignore discharging sensor failure within 3 minutes after compressor is running)
5	coil temp. sensor Tc failure	the sensor is in open circuit or short circuit for 30 seconds, resumable and keep well if no alarm within 3 minutes
10	EEPROM failure	read/write EEPROM data incorrectly, and flash for 10 times, non-resumable
11	discharging temp. Td protection	after compressor begins to soft start up, Td sensor is over 120degree for 10 seconds, compressor stops and alarms in 5 seconds; 3 minutes later, resumable.
13	high pressure switch failure	high pressure switch acts, failure code will disappear after it is solved 3 minutes later
14	low pressure switch failure	low pressure switch acts, failure code will disappear after it is solved 3 minutes later
16	suction temperature Ts protection	Ts is over 40degree for 10 minutes continuously when compressor is running, resumable 3 minutes later
20	communication with power module failure	not receive the signal from power module board for 15 seconds continuously or data received incorrect, once data is correct, resumable automatically, and without 3-minute failure display
21	ACII current of compressor protection	after current protection acts and the unit stops, indicator will flash 21 times and digital tube also displays 21, 3 minutes later, failure will resumable. If the current failure alarms for 30 minutes and has been confirmed for 3 times, the code will display on digital tube, non-resumable. The former 2 failures will not be sent to indoor
22	communication with indoor failure	can not find any indoor in 10 seconds or the data is incorrect, digital tube will display 22. After receiving correct information, resume automatically
23	IPM failure	module occurs failure and keep for 3 minutes
24	Fin over heat/IPM temperature too high	
25	Over current at acceleration state (Hardware trip)	
26	Over current at steady state (Hardware trip)	
27	Over current at deceleration state (Hardware trip)	
28	DC Bus under voltage	
29	DC Bus over voltage	
30	Over current at acceleration state (Software trip)	
31	Over load trip	
32	Over current at steady state (Software trip)	

failure code	failure	description
33	Over current at deceleration state (Software trip)	module occurs failure and keep for 3 minutes
34	Compressor is not connected	
35	Communication loss time out	
36	switch over failure (occurs 4 times continuously at interval of 10 seconds)	
37	out of step	
38	reset	
39	the other abnormal(sensor in open circuit or short circuit, or acceleration from 8 to 20Hz failure)	
40	current detecting failure(not less than 40Hz, DC current less than 1.4A)	
g	not mentioned failure above	

Indoor failure code list

indication on wired controller	flash times of LED5 on indoor PCB/timer LED on remote receiver	flash times of health LED on remote receiver	failure code definition
01	1	--	indoor ambient temp. sensor Ta failure
02	2	--	indoor coil temp. sensor Tc1 failure
03	3	--	indoor coil temp. sensor Tc2 failure
04	4	--	indoor TES sensor failure
05	5	--	indoor EEPROM failure
06	6	--	communication between indoor and outdoor failure
07	7	--	communication between indoor and wired controller failure
08	8	--	indoor drainage failure
09	9	--	indoor repeated address
0A	10	--	indoor repeated central control address
0C	12	--	failure when PCB detects AC current at piont 0(power cable or power source circuit on PCB failure)□
20~87	20	--	outdoor corresponding failure
--	--	1	wall mounted unit P/G motor failure
--	--	2	EEPROM of wall mounted unit board A failure
--	--	3	communication between wall mounted board A and wired controller failure
--	--	4	serial communication failure between wall mounted board A and B
--	--	5	set modes of wall mounted board A and B conflict

Note: When indoor units occur abnormal modes, the earlier entering mode will be prior, and the latter operated unit will be standby. If the unit is remote control type, the buzzer will sound twice, and the sent signal will not be received. It is not failure.

Troubleshooting:

1.Communication failure

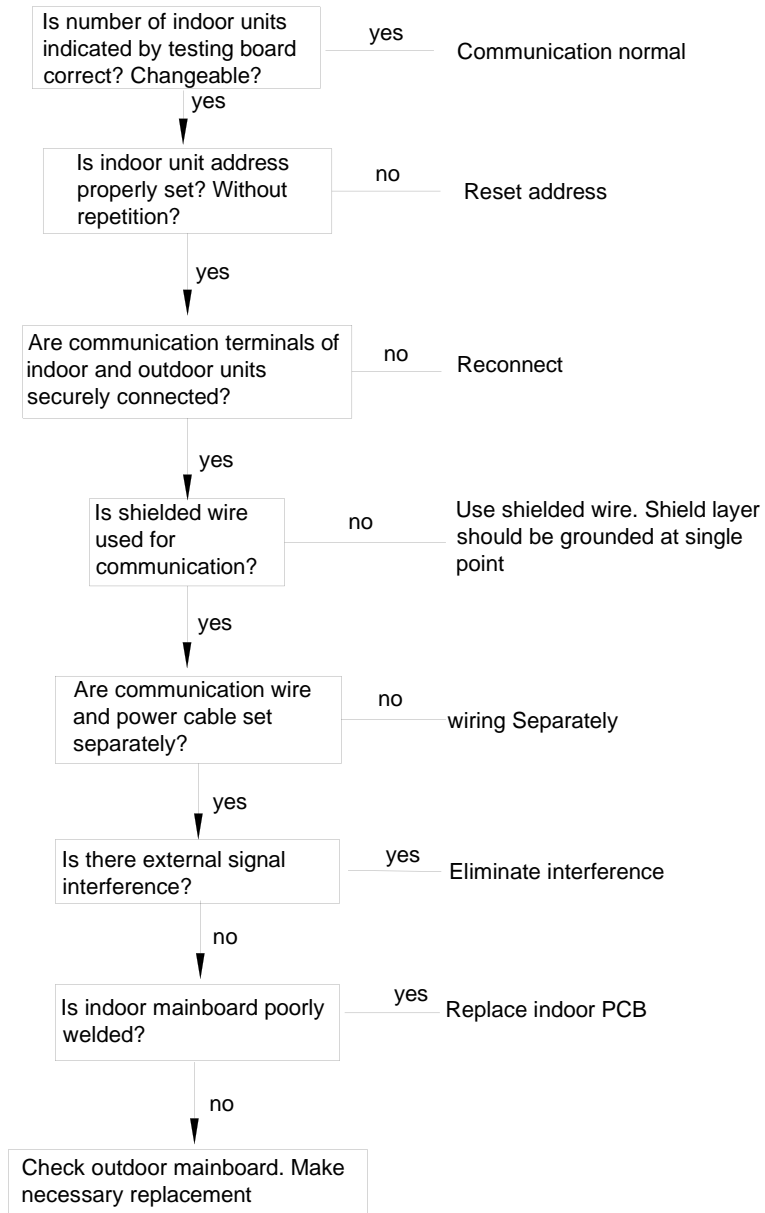

2.Sensor failure

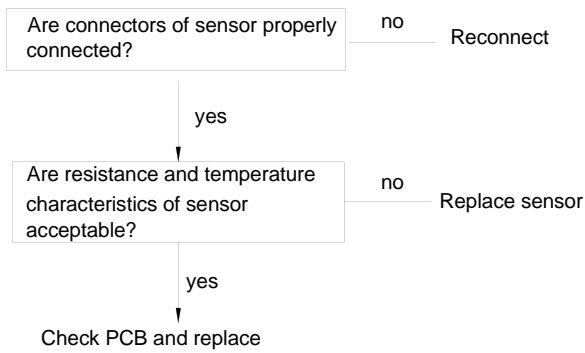

3.EEPROM failure

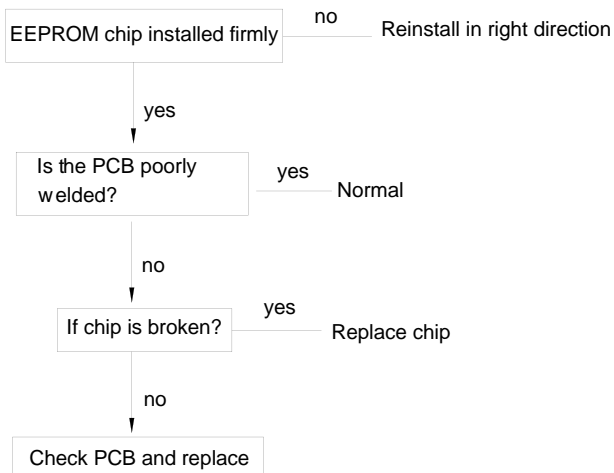

4. Over current protection

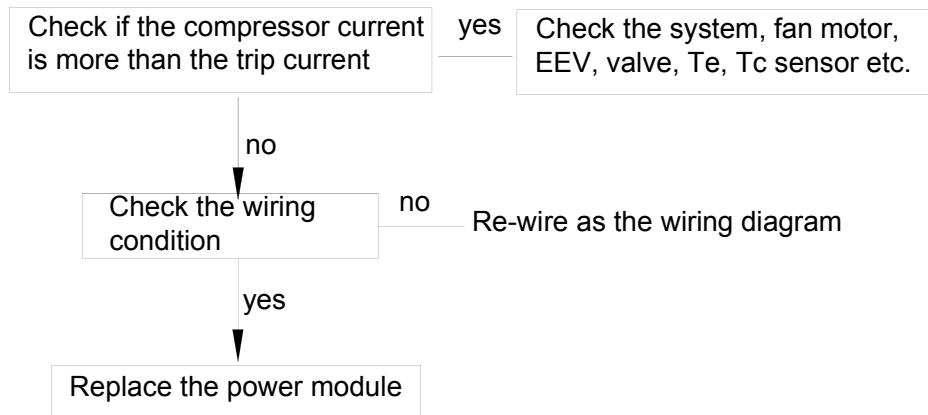

5. Discharging temperature protection

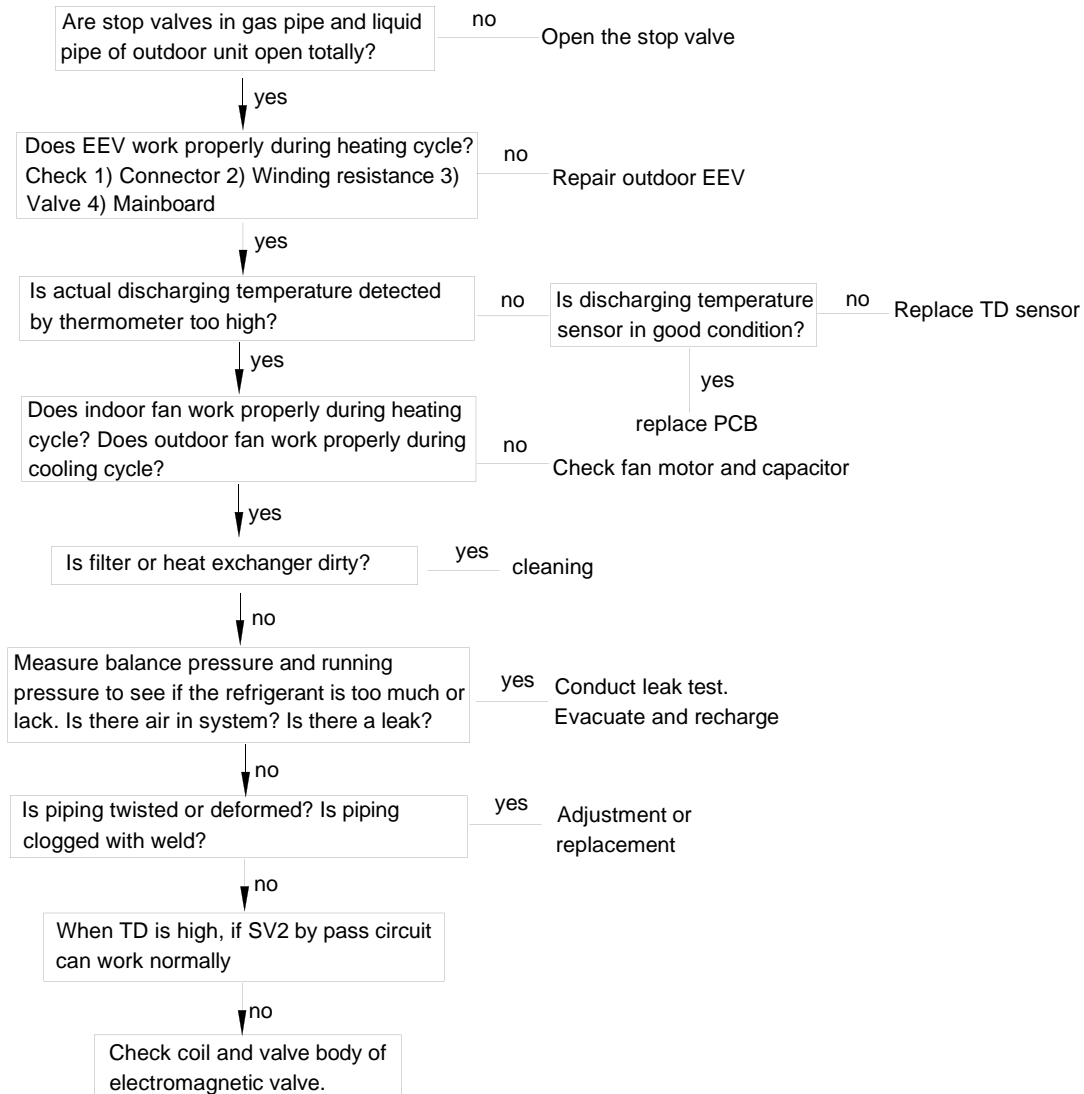

6. High pressure overhigh protection

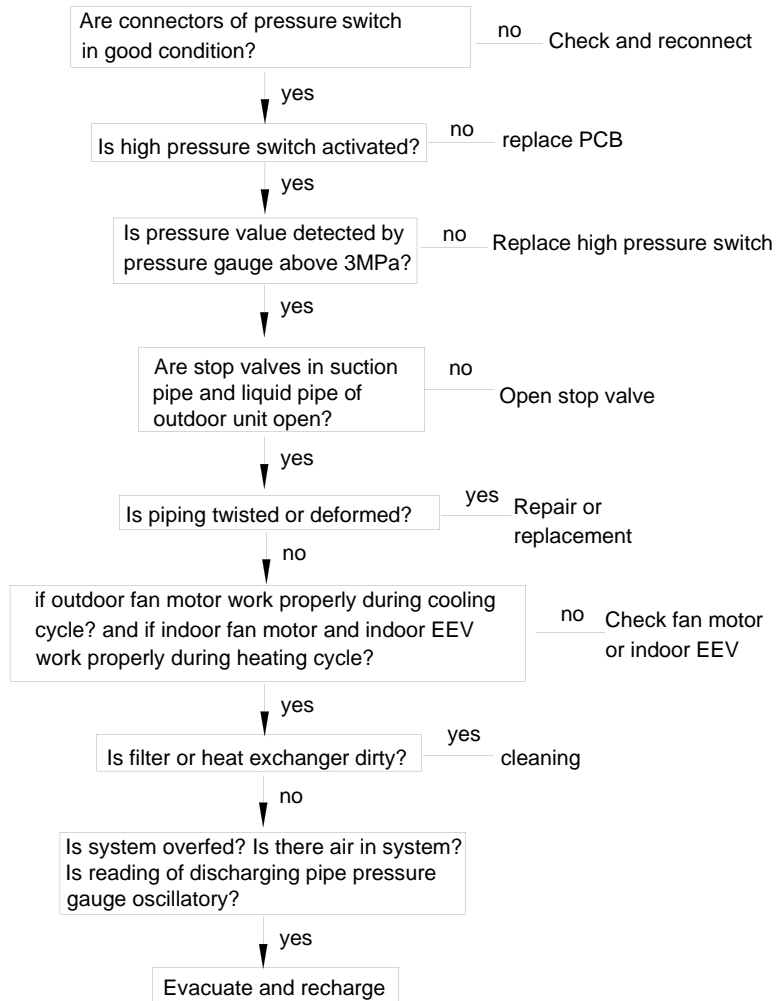

7. Low pressure too low protection

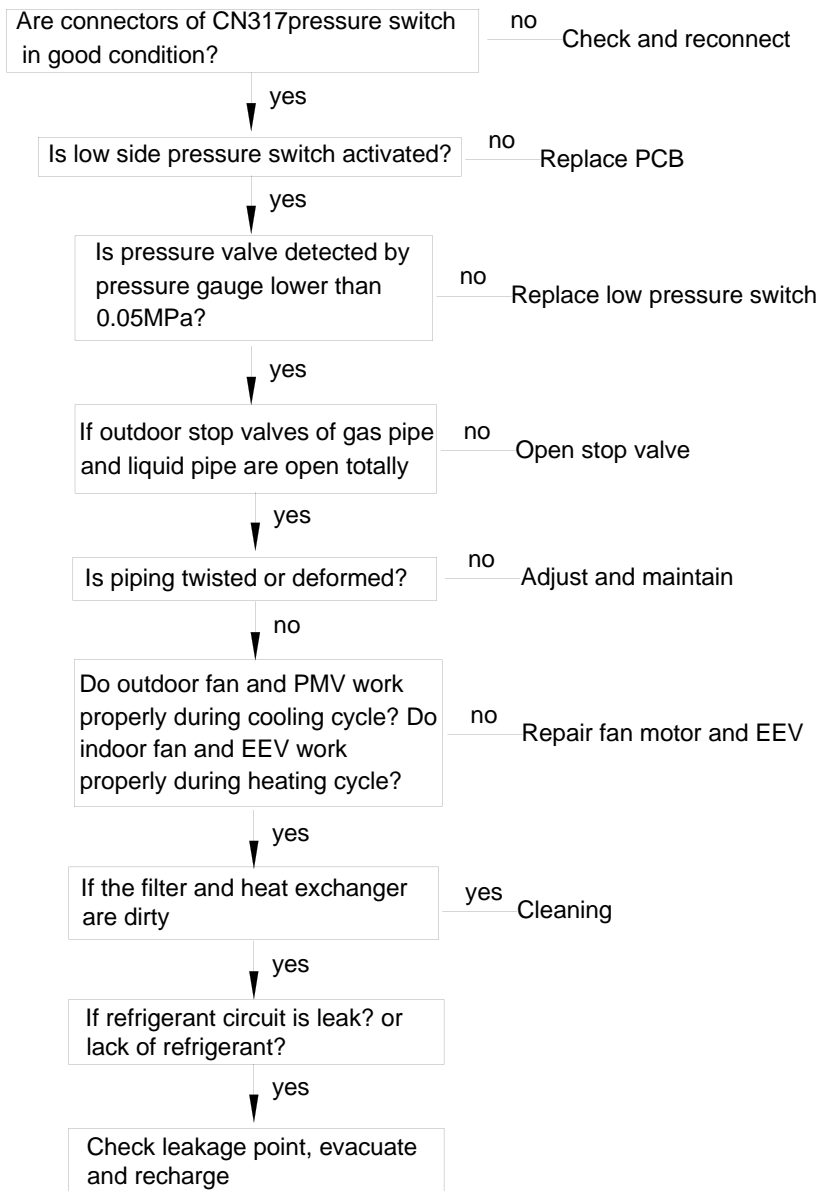

8. Suction temperature protection

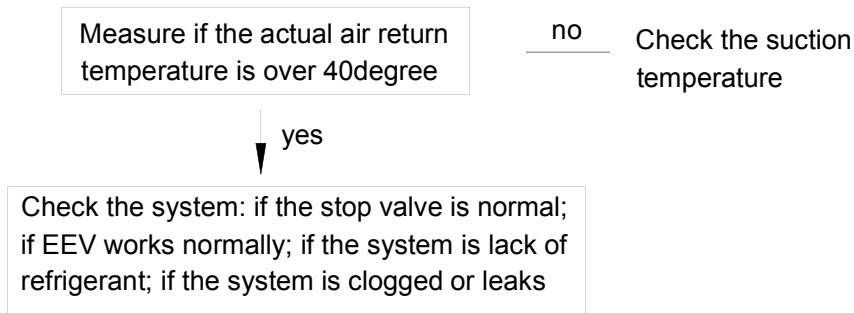

9. Communication with power module failure

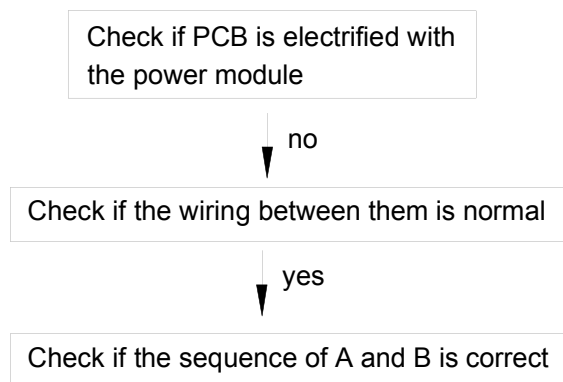

10. Failure code from 24 to 27, from 30 to 40

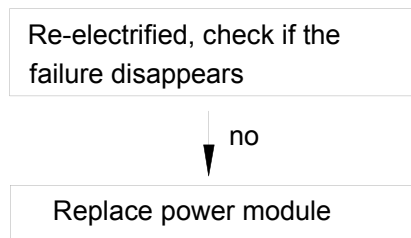

11. Failure code 28 and 29: Check if the voltage input is in the range of $380V \pm 15\%$. Then check if the wiring connection is proper, such as if the terminal of power module is inserted firmly, PTC control wire is normal.

Sensor characteristic

1. Temp. sensor characteristic

No.	sensor type	characteristic
1	indoor coil/ outdoor suction/ oil temp./ defrost/ ambient temp. sensor	R(25°C)=10K Ω B(25°C/50°C)=3700K
2	wired controller ambient temp./indoor ambient temp. sensor	R(25°C)=23K Ω B(25°C/50°C)=4200K
3	outdoor discharging temp. sensor	R(80°C)=50K Ω B(25°C/80°C)=4450K

Herein, the sensor typical resistor is as follows:

(1) R(25°C)=10K Ω B(25°C/50°C)=3700K

temp. sensor			
temp.(°C)	resistor(KΩ)	temp.(°C)	resistor(KΩ)
- 10	51.8	60	2.660
- 5	39.55	65	2.223
0	30.88	70	1.912
5	24.30	75	1.630
10	19.20	80	1.395
15	15.38	85	1.200
20	12.36	90	1.035
25	10.00	95	0.8967
30	8.141	100	0.7796
35	6.668	105	0.6802
40	5.492	110	0.5955
45	4.549	- 15	66.53
50	3.788	- 20	87.42
55	3.170	-25	116.0

(2) $R(25\text{ }^\circ\text{C})=23\text{K } \Omega$ $B(25\text{ }^\circ\text{C}/50\text{ }^\circ\text{C})=4200\text{K}$

temp. sensor			
temp.($^\circ\text{C}$)	resistor($\text{K}\Omega$)	temp.($^\circ\text{C}$)	resistor($\text{K}\Omega$)
- 10	139.5	60	5.243
- 5	105.3	65	4.336
0	80.14	70	3.603
5	61.51	75	3.008
10	47.58	80	2.522
15	35.36	- 20	251.8
20	27.93	- 19	235.9
25	23.00	- 18	223.1
30	18.30	- 17	210.1
35	14.65	- 16	197.9
40	11.79	- 15	186.5
45	9.556	- 14	176.9
50	7.780	- 13	165.9
55	6.371	- 12	156.5

(3) $R(80\text{ }^\circ\text{C})=50\text{K } \Omega$ $B(25\text{ }^\circ\text{C}/80\text{ }^\circ\text{C})=4450\text{K}$

temp. sensor			
temp.($^\circ\text{C}$)	resistor($\text{K}\Omega$)	temp.($^\circ\text{C}$)	resistor($\text{K}\Omega$)
15	878.5	85	41.5
20	621.4	90	34.8
25	599.9	95	29.6
30	398.6	100	25.0
40	246.4	105	21.7
50	160.4	110	18.7
60	105.3	115	16.0
70	72.1	120	13.8
75	59.5	125	11.9
80	49.3	130	10.3