

Central Controller Operation & Installation Manual

RWV06

CONTENT

Function introduction of central controller.....	1
Part info for central controller	2
Page & Key Explanation.....	4
Address Setting When Using Central Controller	6
System structure chart.....	12
Function Operation	14
Installation	35

- Please read this operation manual before using the air conditioner.
- Please keep this manual carefully and safely.

Function introduction of central controller

1. RWV06 can control VRF and SuperMatch (including single split and multi split). 256 indoor units can be controlled when used with VRF and 128 indoor units when with single split & supermatch.

① When controlling VRF, RWV06 should be used together with ADV01.

One ADV01 is connected with one system of VRF firstly and then all IGU05s are hand in hand connected to RWV06.

How to choose VRF: System Settings-Local-Type Select-VRF.

② When RWV06 controls the SuperMatch series, each indoor unit requires one YCJ-A002 as the adapter. The YCJ-A002 adapters are connected with RWV06 hand in hand.

How to choose multi: System settings — Local – Type Select– Single

2. Main functions of central controller

① Monitoring and controlling indoor running state such as ON/OFF, Mode, Fan, Set temp. and error code.

② Zone setting, editing and deleting.

③ Realizing ON/OFF, mode, fan, temperature setting for single/zone/all indoor unit(s).

④ Checking indoor unit detailed information such as real temperature, coil temperature, error code.

⑤ For VRF, three kinds of controlling mode: LIFO, Central & Force can be selected for indoor units; while only Force & LIFO mode can be selected for single split unit.

LIFO: the indoor unit will execute the last order send by central controller, wired controller or remote controller. For example, if firstly sending low speed fan order by central controller and then sending high speed fan order by wired controller, the indoor unit will execute high fan.

Central: central controller enjoys all functions while wired & remote controller can only control ON/OFF of indoor units.

Force: central controller enjoys all functions while wired & remote controller cannot control indoor units.

⑥ Receiving outer signal input: when receiving outer fire alarm signal, central controller will turn all indoor units off.

⑦ Weekly timer setting. Weekly timer for one or some or all units can be set and can run in cycle.

Part info for central controller

ON/OFF key:

Press the ON/OFF key for 2-3 seconds to turn on the controller after powering on. Keep pressing the ON/OFF key for 5 seconds to turn off.

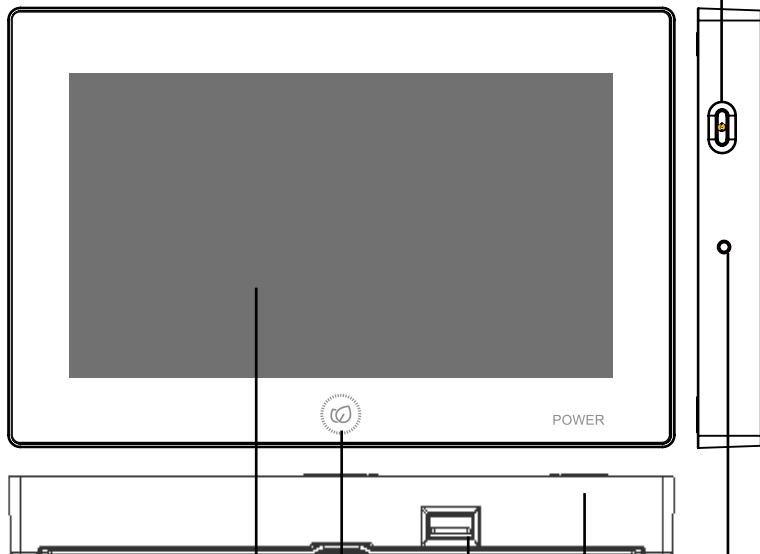

Display/touch screen:

Display and operation area.

USB:

Reserved

Screensaver key:

Press to turn off screen light and press again to turn on.

Power light:

Power light will be on after powering on.

Reset key:

Press to reboot central controller.

Part info for central controller

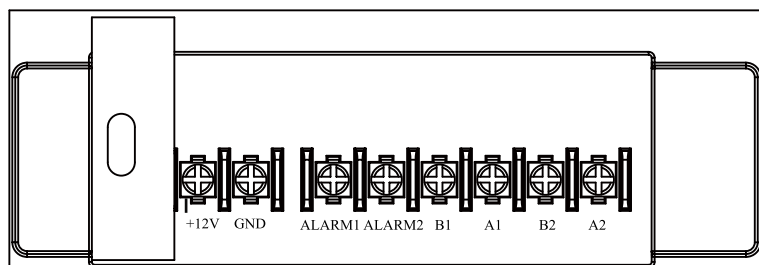
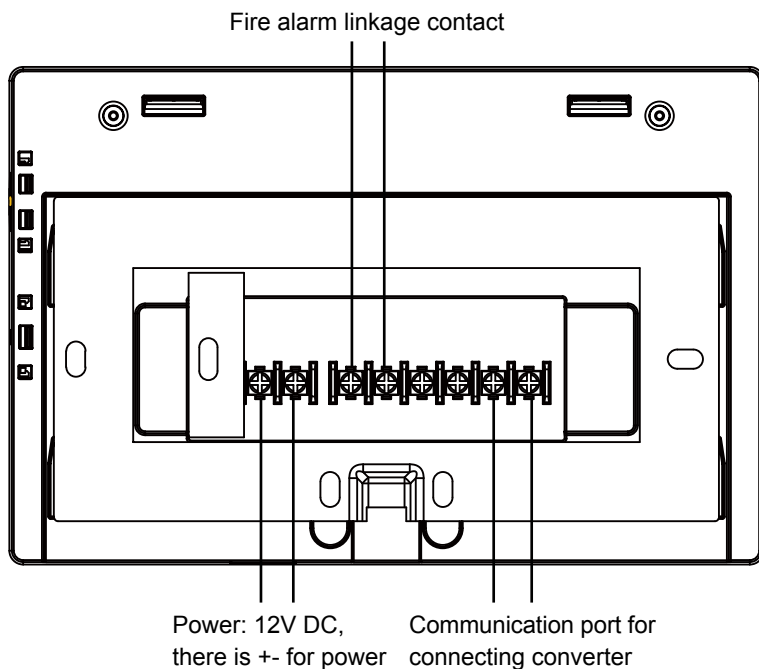





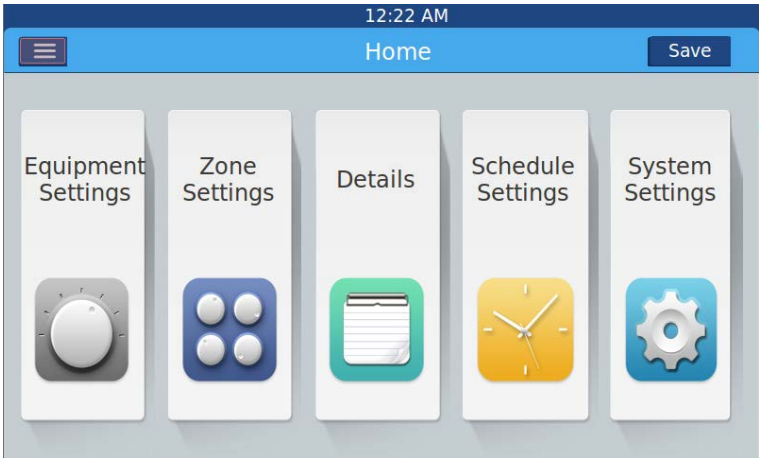

Power (12V, GND): 12V DC, please pay attention to +-of power.
Fire alarm linkage contact (ALARM1, ALARM2): AC works normally when closed and all AC turned off when open circuit.
B1, A1: Reserved
Communication port (B2, A2): It is used for connecting converter, please pay attention to +-. A2 should be connected to 485+ while B2 485-.

Page & Key Explanation



After turning on central controller, home page will show as above and detailed menu is as following:

Menu/icon	Function
<p>AC detailed menu</p> 	<p>POP will show after click the icon:</p> <ul style="list-style-type: none">  Online AC qty: indicating indoor unit quantity in good communication.  Offline AC qty: indicating indoor unit quantity in good communication previously and then in bad communicaiton  AC qty set in timer: indicating AC quantity set timer function  Error AC qty: indicating AC quantity in malfunction.
<p>Equipment Settings</p> 	<p>Press to enter equipment setting interface and do settings as follows:</p> <p>Display all AC list and condition information. Turning page for more information</p> <p>AC mode can be checked and adjusted according to zone/group. And application range can be selected and it can realize All on/All off function.</p>

Page & Key Explanation

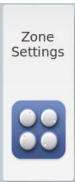
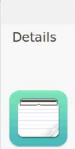
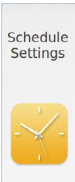
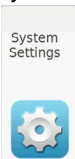
Menu/icon	Function
<p>Zone Settings</p> 	<p>Press to enter Zone Settings interface and do settings as follows: Add/delete group, choose AC, edit group name.</p>
<p>Details</p> 	<p>Click to enter details interface, in which, the following information can be seen: AC condition/mode condition, error code, running time & parameters.</p>
<p>Schedule Settings</p> 	<p>Click to enter schedule settings interface, the following setting can be operated: After entering, it will display all schedule settings lists. One or multi days in a week can be chosen for timing setting. Timer on/off, temperature, mode, fan, temperature range(16-30°C), etc.</p>
<p>System Settings</p> 	<p>Click to enter the interface, and the following setting can be operated: It includes Extra, Energy, Password and Local settings. After clicking icon, relevant operations can be done.</p>

Address Setting When Using Central Controller

When applying central controller, it is required to set address by dip switch for easy checking and maintenance.

When controlling VRF

For every system of AC, address starts from No. 1 to last indoor unit of the system. If totally 20 indoor units are connected in one system, address should be 1-20; if 50 in one system, address should be 1-50; the biggest address is 64.

Note: every indoor address starts from 1.

1. Indoor address setting

The address used in central control or energy system								Central address
SW03								
(1)	(2)	(3)	(4)	(5)	(6)	(7)	(8)	
1	0	0	0	0	0	0	0	Central address=1
1	0	0	0	0	0	0	1	Central address=2
1	0	0	0	0	0	1	0	Central address=3
1	0	0	0	0	0	1	1	Central address=4
1	0	0	0	0	1	0	0	Central address=5
1	0	0	0	0	1	0	1	Central address=6
1	0	0	0	0	1	1	0	Central address=7
1	0	0	0	0	1	1	1	Central address=8
1	0	0	0	1	0	0	0	Central address=9
1	0	0	0	1	0	0	1	Central address=10
1	0	0	0	1	0	1	0	Central address=11
1	0	0	0	1	0	1	1	Central address=12
1	0	0	0	1	1	0	0	Central address=13
1	0	0	0	1	1	0	1	Central address=14
1	0	0	0	1	1	1	0	Central address=15
1	0	0	0	1	1	1	1	Central address=16
1	0	0	1	0	0	0	0	Central address=17
1	0	0	1	0	0	0	1	Central address=18
1	0	0	1	0	0	1	0	Central address=19

Address Setting When Using Central Controller

The address used in central control or energy system								
SW03								Central address
(1)	(2)	(3)	(4)	(5)	(6)	(7)	(8)	
1	0	0	1	0	0	1	1	Central address=20
1	0	0	1	0	1	0	0	Central address=21
1	0	0	1	0	1	0	1	Central address=22
1	0	0	1	0	1	1	0	Central address=23
1	0	0	1	0	1	1	1	Central address=24
1	0	0	1	1	0	0	0	Central address=25
1	0	0	1	1	0	0	1	Central address=26
1	0	0	1	1	0	1	0	Central address=27
1	0	0	1	1	0	1	1	Central address=28
1	0	0	1	1	1	0	0	Central address=29
1	0	0	1	1	1	0	1	Central address=30
1	0	0	1	1	1	1	0	Central address=31
1	0	0	1	1	1	1	1	Central address=32
1	0	1	0	0	0	0	0	Central address=33
1	0	1	0	0	0	0	1	Central address=34
1	0	1	0	0	0	1	0	Central address=35
1	0	1	0	0	0	1	1	Central address=36
1	0	1	0	0	1	0	0	Central address=37
1	0	1	0	0	1	0	1	Central address=38
1	0	1	0	0	1	1	0	Central address=39
1	0	1	0	0	1	1	1	Central address=40
1	0	1	0	1	0	0	0	Central address=41
1	0	1	0	1	0	0	1	Central address=42
1	0	1	0	1	0	1	0	Central address=43
1	0	1	0	1	0	1	1	Central address=44
1	0	1	0	1	1	0	0	Central address=45
1	0	1	0	1	1	0	1	Central address=46
1	0	1	0	1	1	1	0	Central address=47

Address Setting When Using Central Controller

The address used in central control or energy system									
SW03								Central address	
(1)	(2)	(3)	(4)	(5)	(6)	(7)	(8)		
1	0	1	0	1	1	1	1	Central address=48	
1	0	1	1	0	0	0	0	Central address=49	
1	0	1	1	0	0	0	1	Central address=50	
1	0	1	1	0	0	1	0	Central address=51	
1	0	1	1	0	0	1	1	Central address=52	
1	0	1	1	0	1	0	0	Central address=53	
1	0	1	1	0	1	0	1	Central address=54	
1	0	1	1	0	1	1	0	Central address=55	
1	0	1	1	0	1	1	1	Central address=56	
1	0	1	1	1	0	0	0	Central address=57	
1	0	1	1	1	0	0	1	Central address=58	
1	0	1	1	1	0	1	0	Central address=59	
1	0	1	1	1	0	1	1	Central address=60	
1	0	1	1	1	1	0	0	Central address=61	
1	0	1	1	1	1	0	1	Central address=62	
1	0	1	1	1	1	1	0	Central address=63	
1	0	1	1	1	1	1	1	Central address=64	
	0		No need to add 64 to central address						Stay as 0
	1		Add 64 to central address						
0			Central address set by wired controller is available						
1			Central address set by wired controller is unavailable						Stay as 1

Address Setting When Using Central Controller

2. Converter address setting

1	2	3	4	5	6	7	8	Converter address
-	-	0	0	0	0	0	0	1
-	-	0	0	0	0	0	1	2
-	-	0	0	0	0	1	0	3
-	-	0	0	0	0	1	1	4
-	-	0	0	0	1	0	0	5
-	-	0	0	0	1	0	1	6
-	-	0	0	0	1	1	0	7
-	-	0	0	0	1	1	1	8
-	-	0	0	1	0	0	0	9
-	-	0	0	1	0	0	1	10
-	-	0	0	1	0	1	0	11
-	-	0	0	1	0	1	1	12
-	-	0	0	1	1	0	0	13
-	-	0	0	1	1	0	1	14
-	-	0	0	1	1	1	0	15
-	-	0	0	1	1	1	1	16
-	-	0	1	0	0	0	0	17
-	-	0	1	0	0	0	1	18
-	-	0	1	0	0	1	0	19
-	-	0	1	0	0	1	1	20
-	-	0	1	0	1	0	0	21
-	-	0	1	0	1	0	1	22
-	-	0	1	0	1	1	0	23
-	-	0	1	0	1	1	1	24
-	-	0	1	1	0	0	0	25
-	-	0	1	1	0	0	1	26
-	-	0	1	1	0	1	0	27
-	-	0	1	1	0	1	1	28
-	-	0	1	1	1	0	0	Reserved

Address Setting When Using Central Controller

1	2	3	4	5	6	7	8	Converter address
-	-	0	1	1	1	0	1	Reserved
-	-	0	1	1	1	1	0	Reserved
-	-	0	1	1	1	1	1	Reserved
-	-	--	-	-	-	-	-	Reserved
-	-	-	-	-	--	-	-	Reserved

If one indoor unit is connected to ADV01 addressed as No. 1, and its central address is No. 6, the indoor code displayed on central controller is 1-6; if one indoor unit is connected to ADV01 addressed as No. 5, and its central address is No. 20, the indoor code displayed on central controller is 5-20.

Note: when controlling VRF, the RWV06 can control max. 28 ADV01 and max. 256 indoor units. If ADV01 is more than 28 while indoor quantity is less than 256, another RWV06 is needed because ADV01 exceeds 28; If ADV01 is less than 28 while indoor quantity is more than 256, another RWV06 is needed because indoor quantity exceeds 256.

When controlling single or multi split

One indoor unit needs one converter YCJ-A002, YCJ-A002 addressing as follows:

SW01								Definition
[8]	[7]	[6]	[5]	[4]	[3]	[2]	[1]	
0	--	--	--	--	--	--	--	Single mode
1	--	--	--	--	--	--	--	Twin units shifting mode
--	0	0	--	--	--	--	--	Shifting time 1—8 hours
--	0	1	--	--	--	--	--	Shifting time 2—10 hours
--	1	0	--	--	--	--	--	Shifting time 3—12 hours
--	1	1	--	--	--	--	--	Shifting time 4—14 hours
--	--	--	0	--	--	--	--	Twin units running mode when room temp. $\geq 26^{\circ}\text{C}$
--	--	--	1	--	--	--	--	Twin units running mode when room temp. $\geq 24^{\circ}\text{C}$

Address Setting When Using Central Controller

SW01								Definition
[8]	[7]	[6]	[5]	[4]	[3]	[2]	[1]	
--	--	--	--	0	0	0	0	Central address in twin shifting mode=1
--	--	--	--	0	0	0	1	Central address in twin shifting mode=2
----								----
--	--	--	--	1	1	1	0	Central address in twin shifting mode=15
--	--	--	--	1	1	1	1	Central address in twin shifting mode=16
--	0	0	0	0	0	0	0	Central address=1
--	0	0	0	0	0	0	1	Central address =2
----								----
--	1	1	1	1	1	1	0	Central address =127
--	1	1	1	1	1	1	1	Central address=128

RWV06 can control at most 128 indoor units when controlling single or multi split.

System structure chart

1. System structure chart when controlling VRF:

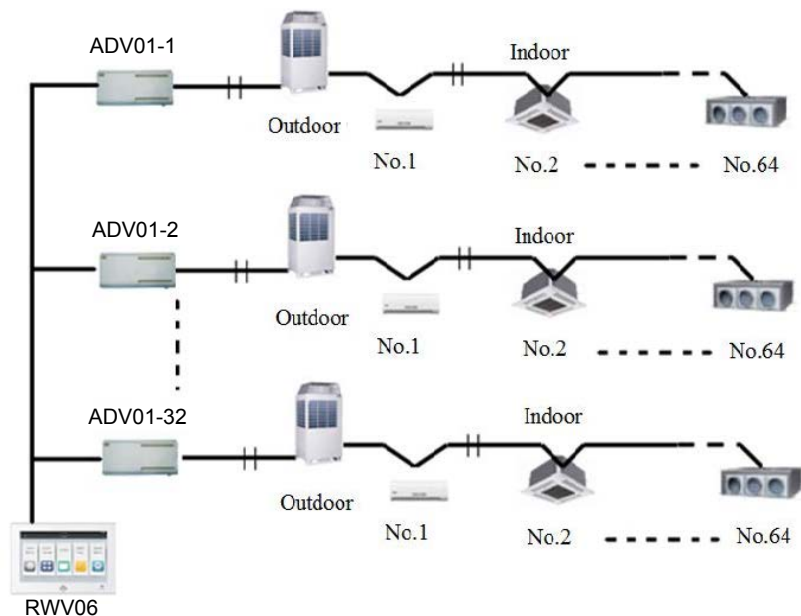

One ADV01 is needed for one AC system, and max. 28 ADV01 can be connected to one RWW06. When indoor unit total quantity is less than 256, the ADV01 quantity connected to one RWW06 cannot exceed 28; When ADV01 quantity is less than 28, the connected indoor quantity cannot exceed 256.

System structure chart

2. System structure chart when controlling single split:

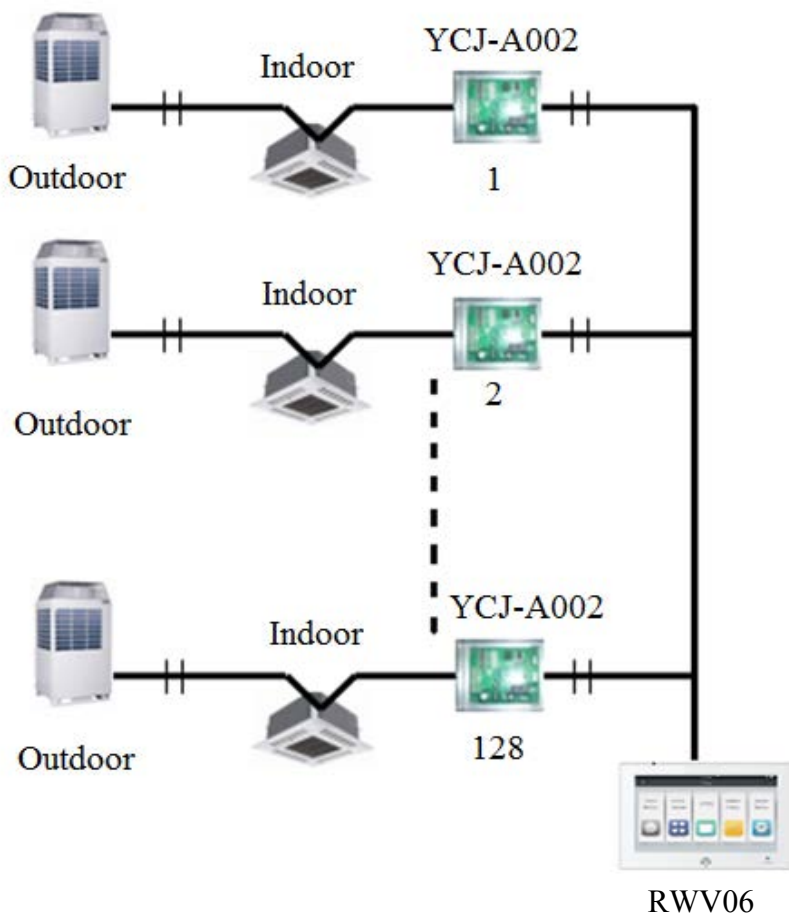

One YCJ-A002 is needed for every indoor unit. Max. 128 YCJ-A002 (as well as max. 128 indoor units) can be connected.

Function Operation

Equipment Settings

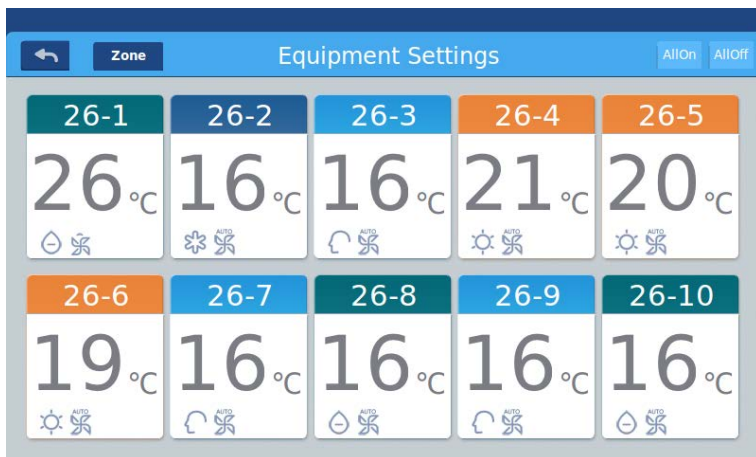

Picture 1

Press the “Equipment Settings” key on home page to enter the display interface as shown in picture 1.

 is the return button. This button is always presented in the column, press this button to return to the last page.

Zone means you can view air-conditioners as grouping established. Press “Zone” button to pop out all the air-conditioner grouped in pop window. If air-conditioners have not been grouped before, it will show all air-conditioners.

Function Operation

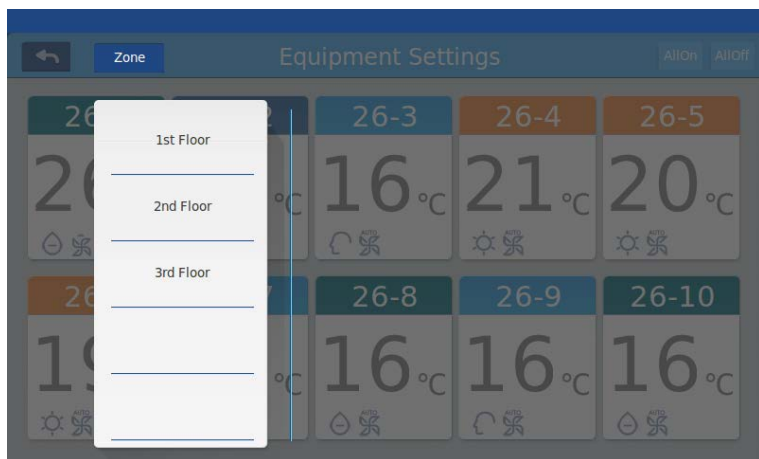

Picture 2

For example: Press the 3rd floor in picture2, it will show all indoor units on the 3rd floor, as shown in picture3.

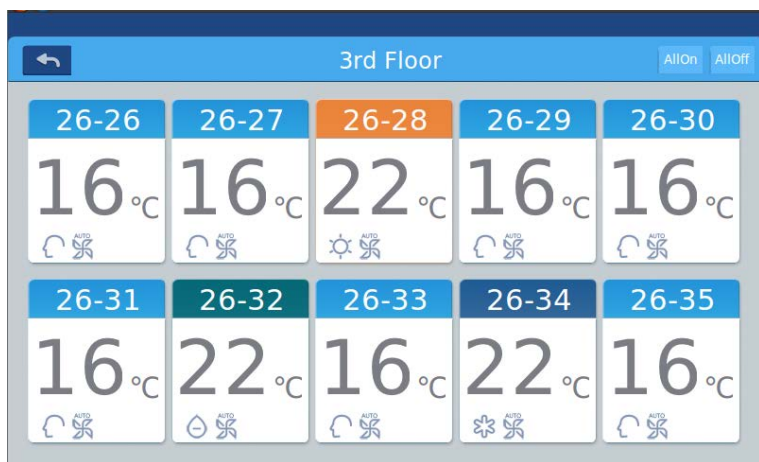

Picture 3

Function Operation

AllOn AllOff is the All on/All off button. If it is displaying all indoor units, then the All on/All off button is used to control all indoor units; if it is displaying the indoor units of one group, then the All on/All off button is used to control the indoor units in this group.

Each grid represents an indoor unit in the air-conditioner display area, and each page can display 10 indoor units. Slide around the screen to turn pages on the screen. Indoor unit is shown as picture 4.

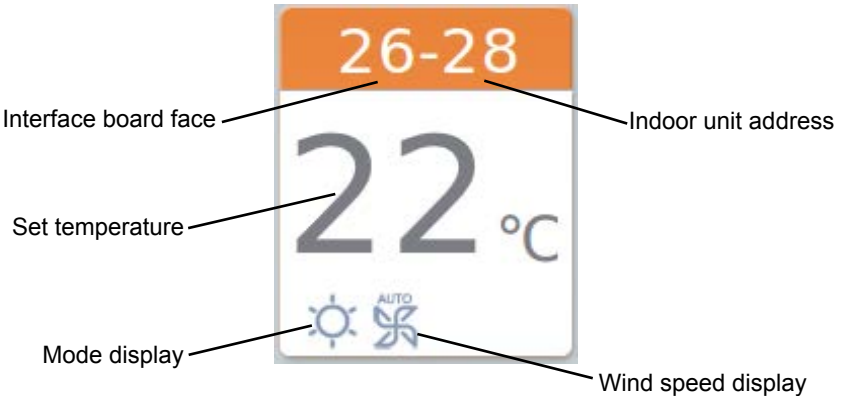

Picture 4

Record: The colors of upper part of the icon represents the operation modes, different mode uses different color to distinguish from each other.

Heating Mode--orange;Cooling Mode--blue; Dry mode--aqua;

Fan mode--wathet;Intelligent Mode--wathet.

Function Operation

Press single air-conditioner icon to enter the air-conditioner setting interface, as shown in picture5

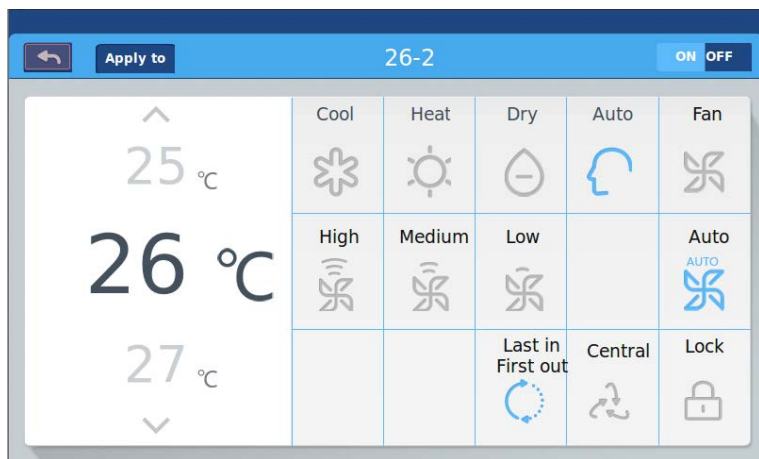

Picture 5

Setting interface:

Temperature setting: By sliding up/down the temperature selection area, you can change the setting temperature. It can be changed by pressing arrow \wedge / \vee too, press once to adjust it one time.

Record: In wind mode, the temperature will be gray and can't be changed.

Set Mode: Press the corresponding mode icon, the setting is successful if the icon is lighted up. Only one mode can be chosen.













Set Wind Speed: Press the corresponding wind speed icon, the setting is successful if the icon is lighted up. Only one wind speed can be chosen.

Record: If you choose the fan mode, you can't choose the automatic wind speed any more.

Set control mode: Last in first out/Central control/Locked, choose one from these three control mode and the icon will be lighted up.

Function Operation

Icon Instruction:

 Cooling Mode	 Last in first out
 Heating Mode	 Central Control
 Dry Mode	 Locked
 Intelligent Mode	 Low Speed
 Wind Mode	 Automatically
 High Speed	 Medium Speed

Function Operation

Batch change the air-conditioner mode setting: After setting one air-conditioner, press **Apply to** and pop window will pop out as shown in picture 6.

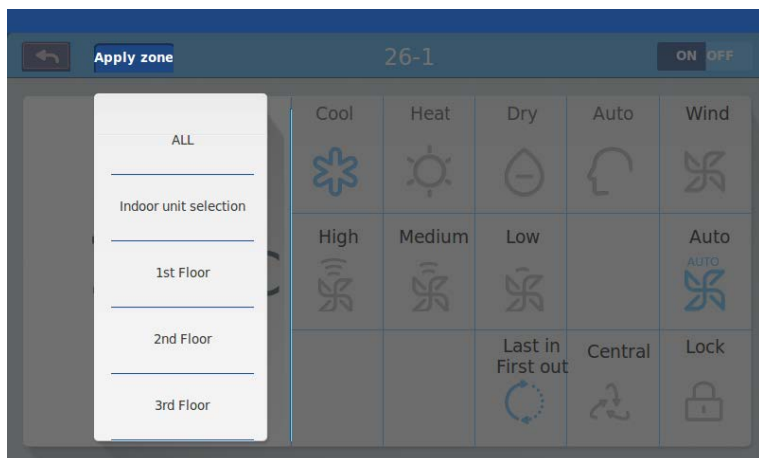

Picture 6

If you choose “All”, then all indoor units will operate as ordered.

If you choose “indoor unit selection”, then the page will turn to interface displaying all indoor units, press the indoor unit icons to choose the indoor units (the chosen ones will turn to dark color), they will operate as ordered.

As shown in picture 6, “1st Floor ” “2nd Floor” “3rd Floor” are three parted area, choose one area and all indoor units in this area will operate as ordered.

Change the name of the air-conditioner: as shown in picture 7, press the air-conditioner number 26-1, then it will display the textbox “please input device name” and click the blank text box to pop out the keyboard. After typing in the name, press “ENTER” to take back the keyboard, then setting name is finished. The longest name can be 12 English letters.

Function Operation

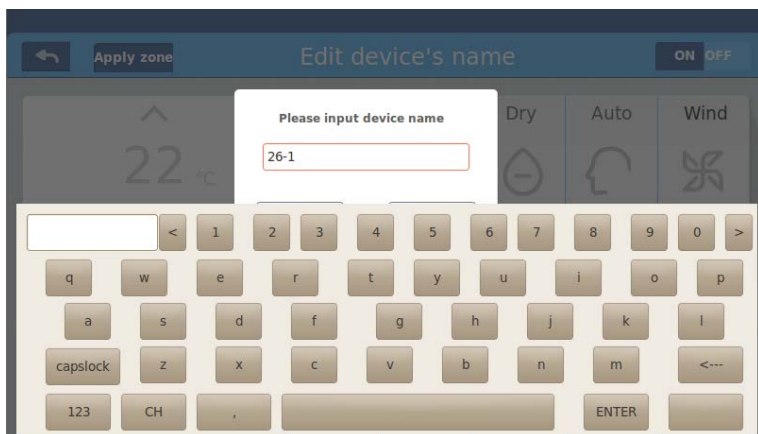

Picture 7

Such as changing the name to “10-16 general manager office”, after changing it will be displayed in center, when you return to the last layer, the corresponding air-conditioner icon name will also be refreshed.

Zone Settings



Picture 1

Function Operation

Press zone settings on the homepage to enter the zone setting interface, as shown in picture1.

It will display setting groups and adding new group button on the left. It will only display adding new group button initially. It will display those air-conditioners which can be grouped. It will display all air-conditioners initially.

Adding new group: press  to pop out the window as shown in picture 2

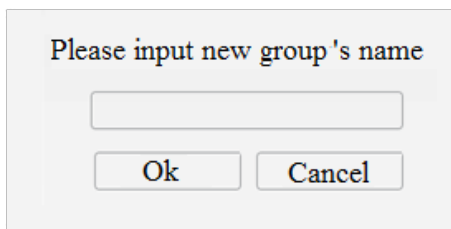

Please input new group's name

Ok Cancel

Picture 2

Click the blank text box, enter the group name (up to 12 English letters) by the keyboard, and press the "ENTER" button of the keyboard after entering. Press OK key in the pop window to enter the interface as shown in picture3.

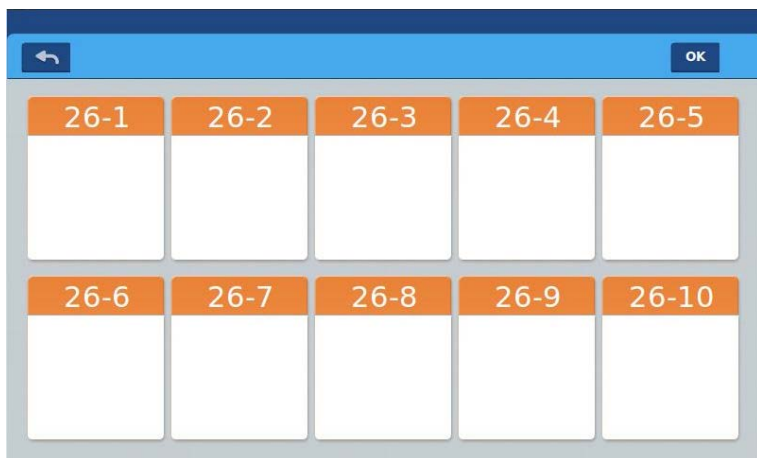

26-1	26-2	26-3	26-4	26-5
<input type="text"/>	<input type="text"/>	<input type="text"/>	<input type="text"/>	<input type="text"/>
26-6	26-7	26-8	26-9	26-10
<input type="text"/>	<input type="text"/>	<input type="text"/>	<input type="text"/>	<input type="text"/>

Picture 3

Function Operation

This interface displays air-conditioner numbers, click to choose those air-conditioners need to be added to grouping. It will turn to blue after being selection, click again to cancel the selection.

For example: choose indoor units 26-1,26-2, it will display as shown in picture 4.

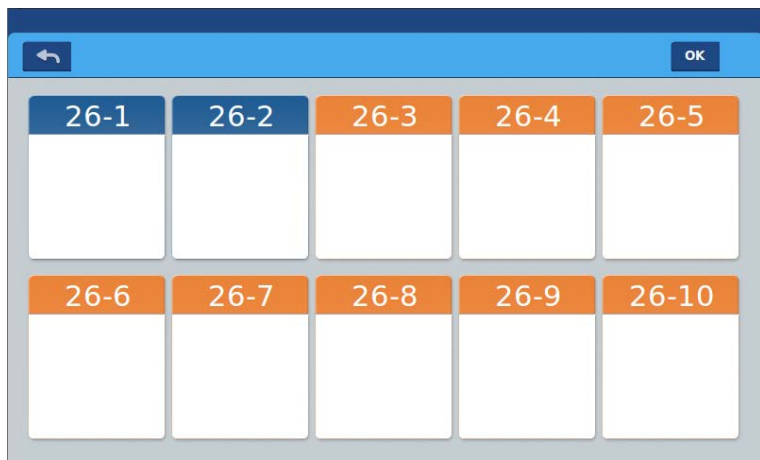

Picture 4

After choosing the air-conditioners, press OK key at the top-right corner, then the grouping is finished, it will create a new group on the left. Click the group name on the left, the background will be highlighted, as these indoor units of the 1st floor area shown in picture 5.

Press  to return to the last layer when grouping air-conditioners.

Function Operation

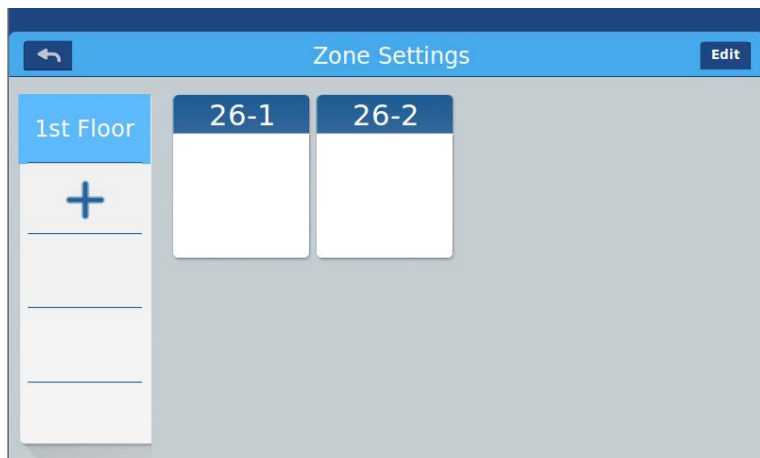

Picture 5

In picture5, choose one group and then click **Edit** button, it will pop out the pop window and it has three lines, as shown in picture6:

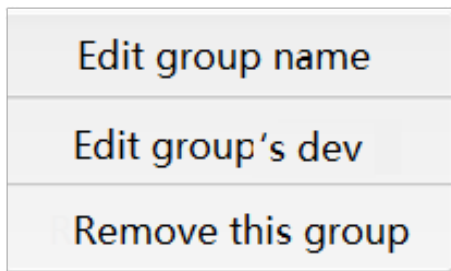

Picture 6

Edit group name: press the key to pop out the pop window of changing the group's name.

Edit group's dev: press the key to pop out the list of indoor units to edit the group's dev.

Remove this group: pop out "to remove this group?" and press OK to delete the group, indoor units will come to "ungrouped", press "cancel" to come back to picture 5.

Function Operation

Details

Press details button on homepage to enter detailed information interface as shown in picture1.



The screenshot shows a mobile application interface titled "Details". At the top left is a back arrow icon, and at the top right is a "Clear" button. Below the title is a table with 10 columns: Unit No., User Name, Device Addr, Ambient Temp., Mode, Fan Speed, Gas Pipe Temp., Liquid Pipe Temp., Running Time, and Error Code. The table contains 8 rows of data. A vertical scrollbar is visible on the right side of the table.

Unit No.	User Name	Device Addr	Ambient Temp.	Mode	Fan Speed	Gas Pipe Temp.	Liquid Pipe Temp.	Running Time	Error Code
001	26-1	26-1	20	Heat	Auto	25	25	0:18	0
002	26-2	26-2	20	Auto	Auto	25	25	0:59	0
003	26-3	26-3	20	Heat	Auto	25	25	0:12	0
004	26-4	26-4	20	Auto	Auto	25	25	0:12	0
005	26-5	26-5	20	Auto	Auto	25	25	0:12	0
006	26-6	26-6	20	Auto	Auto	25	25	0:12	0
007	26-7	26-7	20	Cool	Auto	25	25	0:12	0
008	26-8	26-8	20	Auto	Auto	25	25	0:12	0

Picture 1

Vertical axis displays the name of the air-conditioner according to the order of the unit numbers, horizontal axis displays user name, air-conditioner number, setting temperature, setting mode, setting wind speed, gas pipe temperature, liquid pipe temperature, operating time and faults information.

The progress bar is on the right and slide up and down within the progress bar to see all machine details.

Clicking **Clear** to pop out password input window. Inputting password and click "Ok", all current date(except running time) will be cleared. If clicking "Cancel", it will return to previous page.

Function Operation

Schedule Settings

Choose Schedule Settings on the homepage to enter the initial schedule setting interface as shown in picture 1.

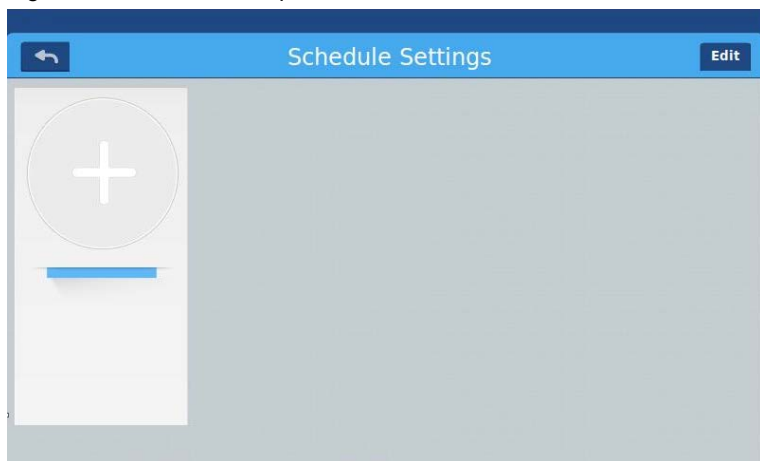

Picture 1

Press  to add new schedule settings. Press this button to enter the setting interface, as shown in picture 2, "On" shows when the machine starts up and "Off" shows when the machine shuts down.

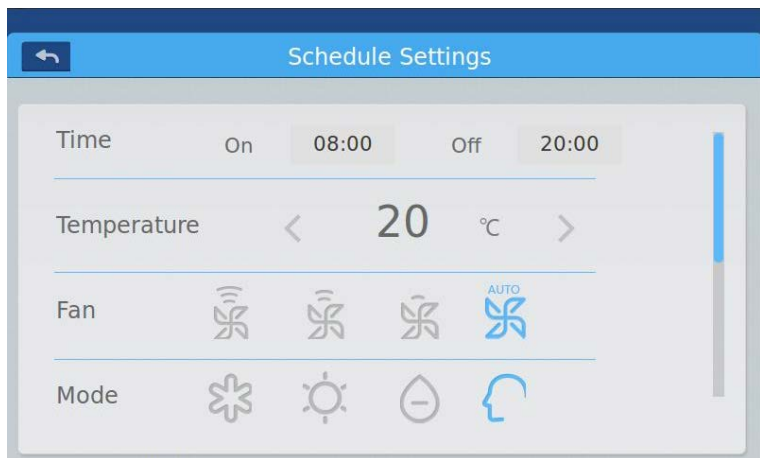

Picture 2

Function Operation

Click the time text (such as 08:00 in picture 2) to pop out the window

Time set	
11	17
12	18
01	19

choose the time of startup. Then set the temperature, wind speed and mode. Slide down and set the area applied to and weekly in the interface as shown in picture3.

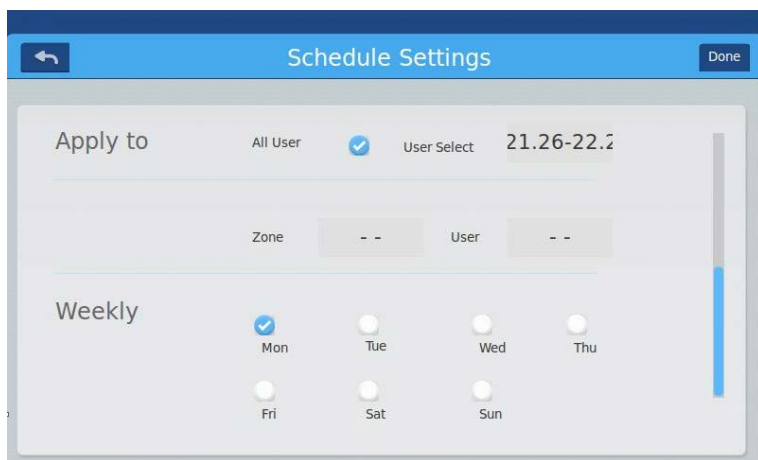

Picture 3

Click "Done" key after setting.

Apply Zone Settings:

For setting all users: Click to select all users

For setting individual user: Click the user selection textbox after all users to pop out the POP window, it will display all users, as shown in picture 4.

Function Operation

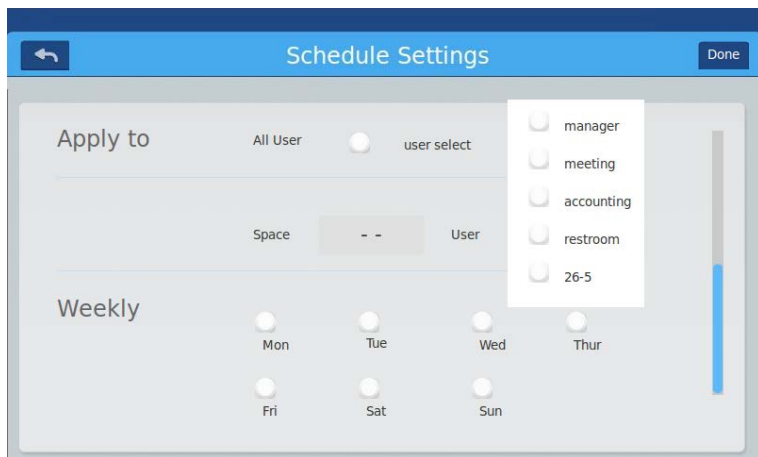

Picture 4

Click the frame before the user's indoor unit which you want to set, it will show a hook after selection.

Zone setting: click the zone to pop out the pop window as shown in picture 5, choosing it by clicking the frame before the area.

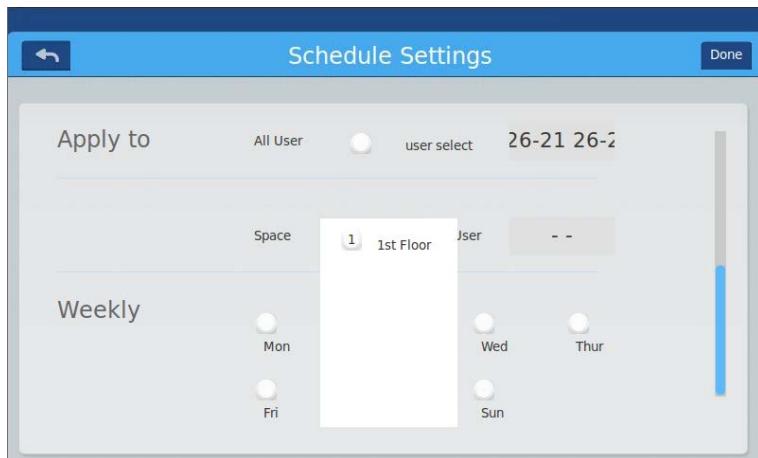

Picture 5

Function Operation

For setting individual indoor units of one area: Choose the area first and then click the user selection textbox on the right, it will pop out the pop window as shown in picture 6.

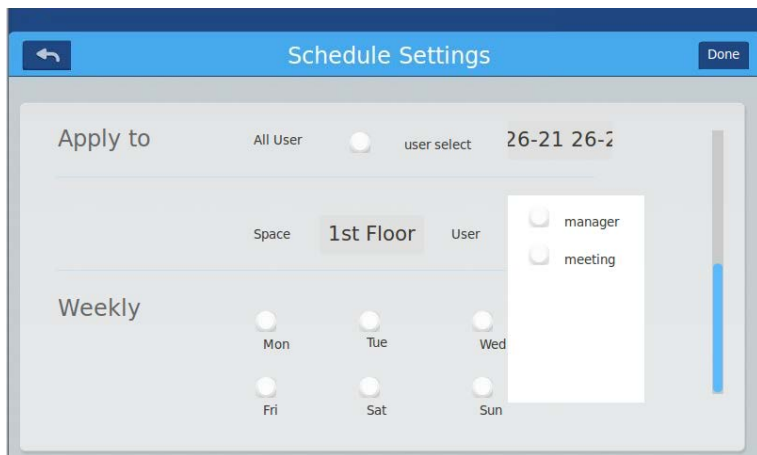

Picture 6

Select those indoor units which you want to choose by clicking the frame before them, it will show hook after selection.

After setting the apply area, click blank area and pull-down lists will close.

Weekly:

From Monday to Sunday, it will show a hook after click, it will operate the schedule on the day you have chosen, it will circulate weekly.

It will display the setting schedule as shown in picture 7, ON/OFF time will be shown below the dial plate, press the dial to enter the picture 2, you can adjust the setting time, fan speed and mode.

Function Operation

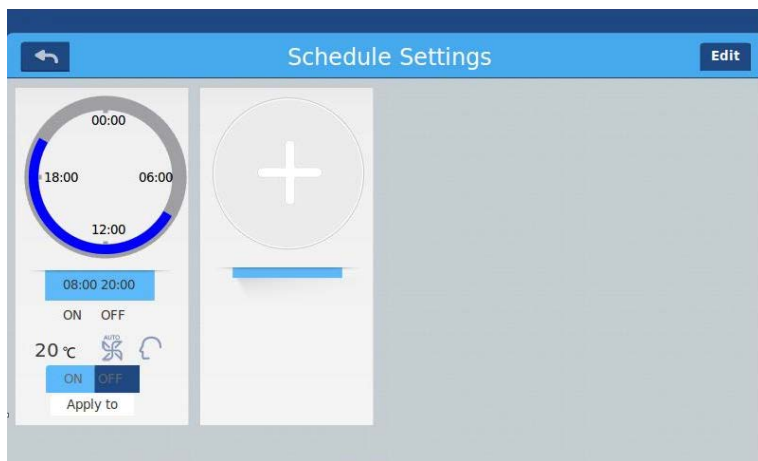

Picture 7

“On/Off”: setting the startup/shutdown of the schedule template.

Check the applied air-conditioners: click the “Apply to” below the schedule setting template, and you can check which indoor units are applied by the schedule setting template as shown in picture 8.

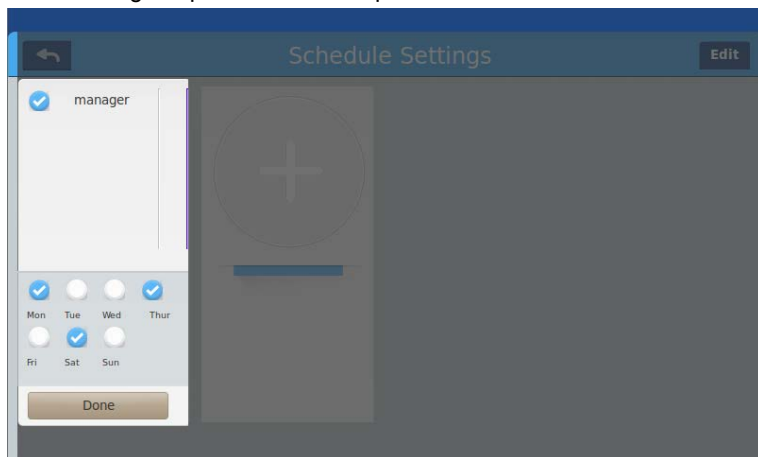

Picture 8

It displays the indoor units above. If there are too many indoor units, you can slide up and down to check them. It displays the weekly cycle settings below.

Function Operation

system settings

It need password to enter setting page. Click “system settings” button on the home page, you will see the picture1 below.

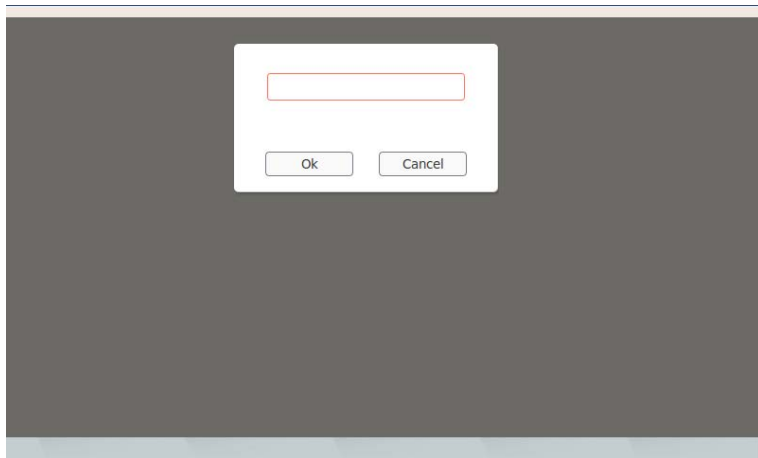

Picture 1

Click OK key enter system settings page after inputting password. System setting page includes 4 contents, as picture 2.

Extra

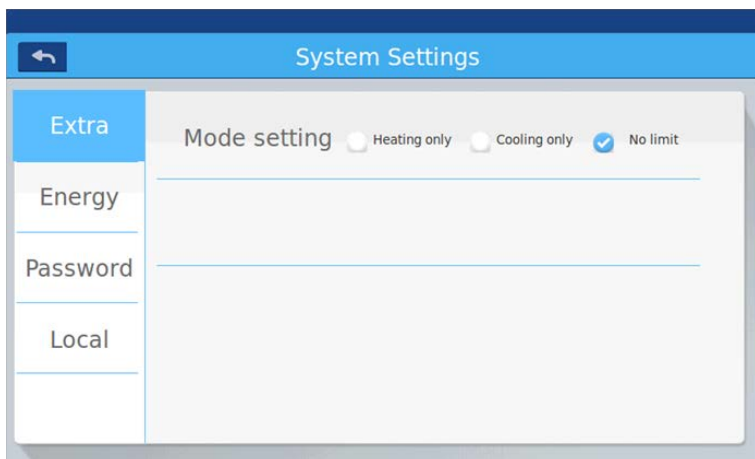

Picture 2

Function Operation

Mode setting: Click to choose model setting. It will show if you pitch on. Default is no limit.

Energy

As picture 3, 4

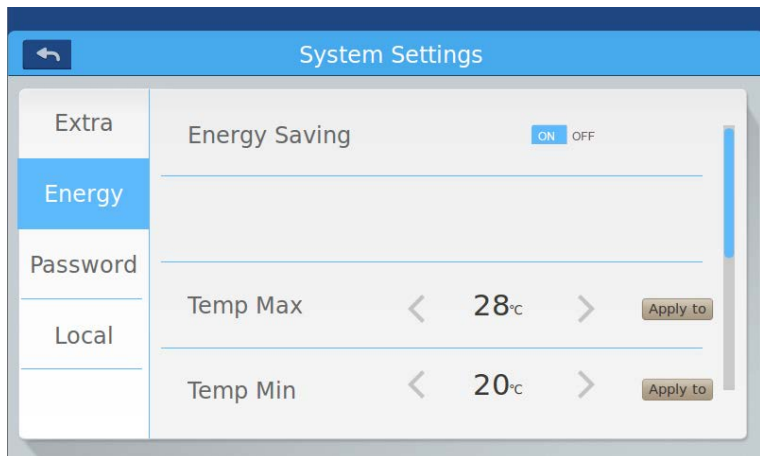

Picture 3

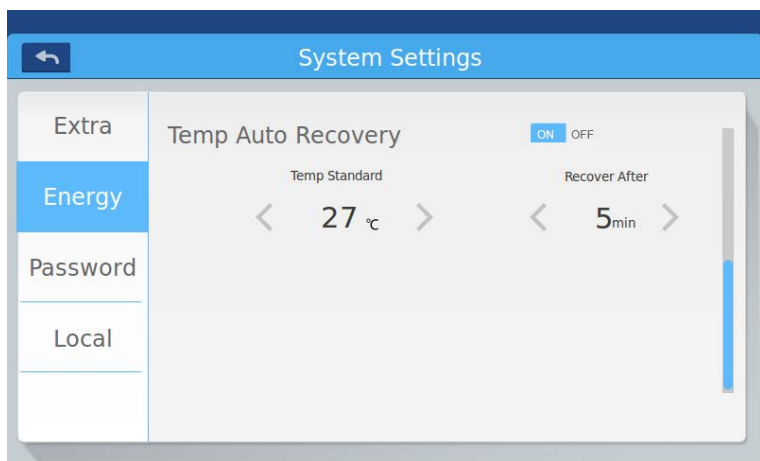

Picture 4

Function Operation

Energy Saving: You can set saving function through the button ON OFF . Default is "ON".

Temperature maximum setting: You can turn up or down the maximum temperature through operating or . After setting, Click , you will see a pop window what you can choose "apply to all zone" or "apply to one zone". The upper limit and lower limit of temperature take effect only when temperature limit are applied to zone. (when remove temperature upper limit of one zone, need to set upper limit 30 and lower limit 16)

Temperature minimum setting: same as above.

Temp Auto Recovery: You can set the function through the button ON OFF . you can operate or to set standard temperature and then recovery time.

Password

As picture 5

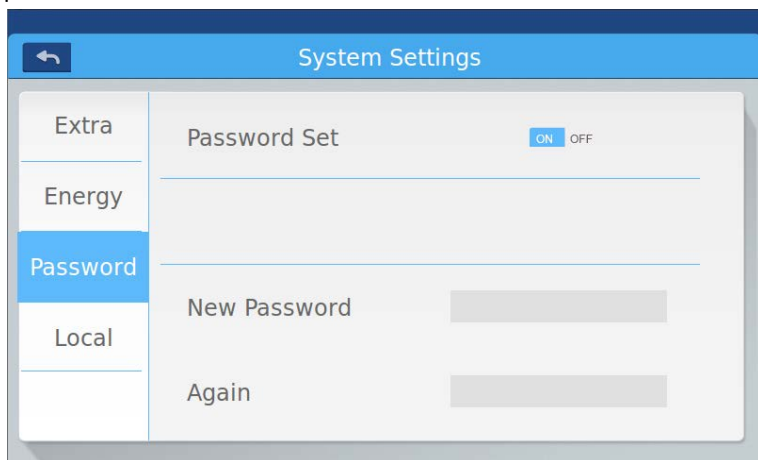

Picture 5

Password setting: You can choose ON OFF to decide if password is necessary.

Input/confirm new password: Input the password (length 4-10) twice. It will remind "update password ok", the new password will come into effect when you leave this page. Otherwise it will remind "update password fail".

Remark: default password is 12345.

Function Operation

Local setting

As picture 6 and picture 7.

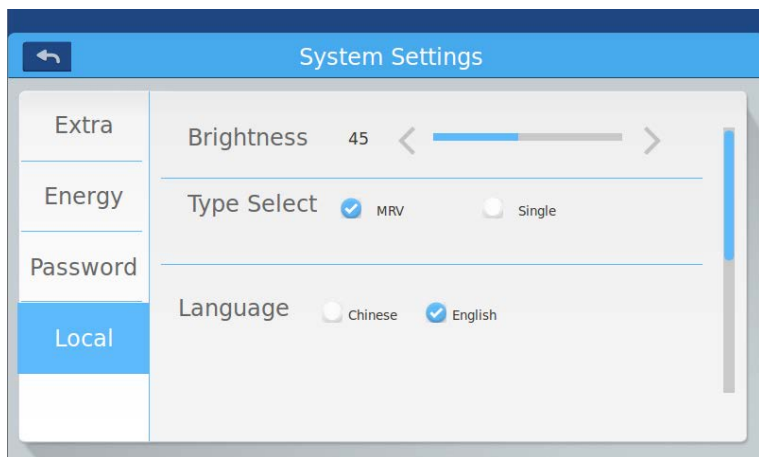

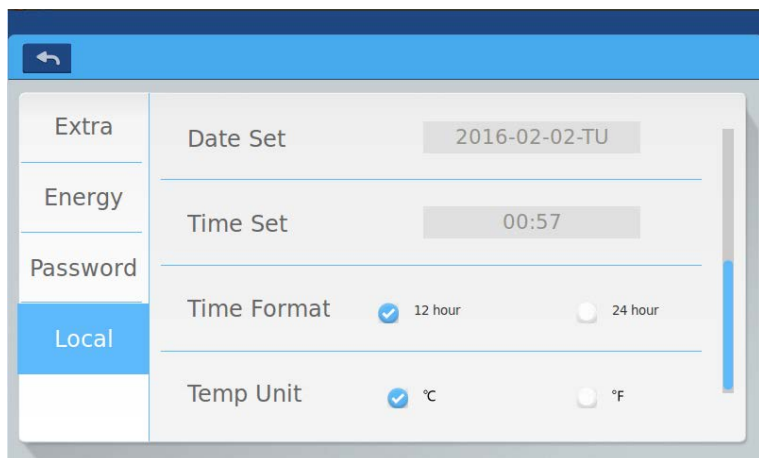

Picture 6



Picture 7

Function Operation

Brightness setting: You can turn up or down through the button  and .

Type selection: Choose your unit model. It will show  after you pitch on the unit type.

Language selection: Choose language. It will show  after you pitch on the language.

Date and week setting: It will show a date pop window after you click the date

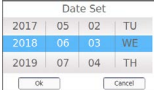
box; you can choose the date and week through .

Time setting: It will show a time pop window after you click the timebox, you

can choose the time through .

Time format: It will show  after you pitch on the time format.

Temperature unit: It will show  after you pitch on the temp. unit.

Remarks:

- ① When there is change on device name, zone settings, schedule settings, system settings, press “Save” on the top right corner of home page.
- ② The auto-recovery temperature valve can only be set between upper limit and lower limit.
- ③ When set zone, indoor units quantity in one zone cannot exceed 64.
- ④ In the interface of Equipment setting, Zone settings and Schedule settings, turn page to right or left is available.
- ⑤ When choose VRF in System settings,HRV can be controlled, 485 terminal of HRV together with ADV01 are hand in hand connected to RWV06, SW903_2,3 is used to set address, 00~11 stands for indoor unit 1~4, total amount of HRV and VRF indoor units cannot exceed 256.
- ⑥ For HRV, only single control and AllOn/AllOff are available, zone setting and schedule setting is not available.

Installation

Installation dimension

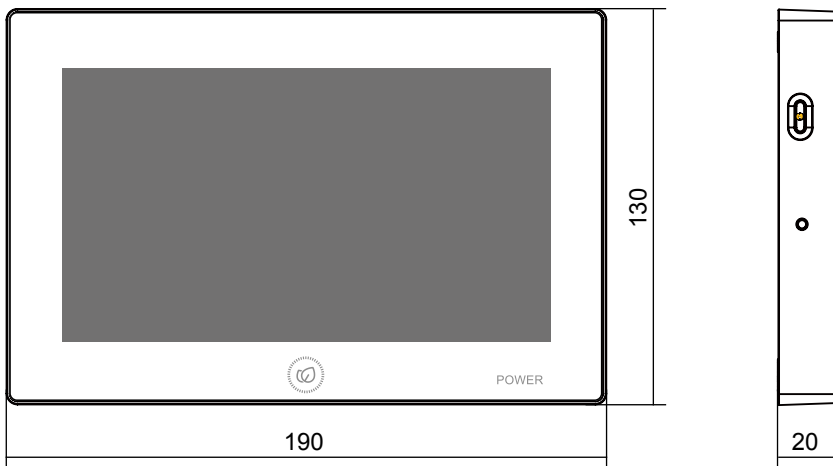

Wiring diagram

Wiring diagram between central controller and converter board (ADV01).

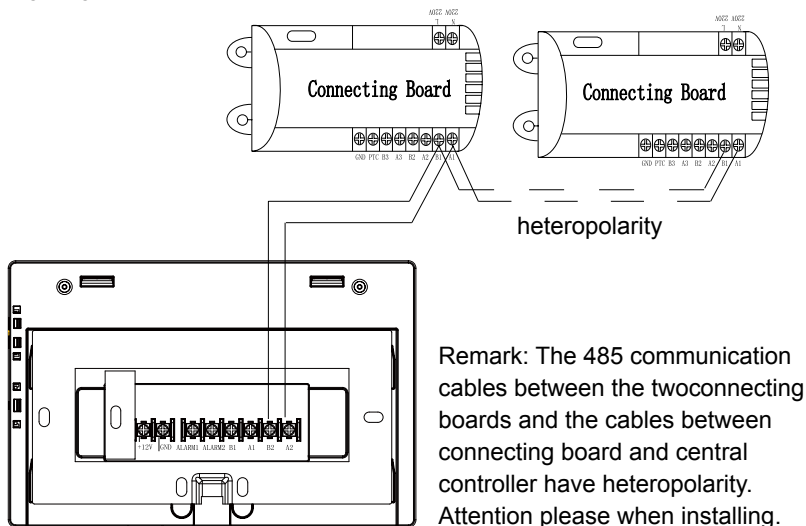

Installation

Installation dimension

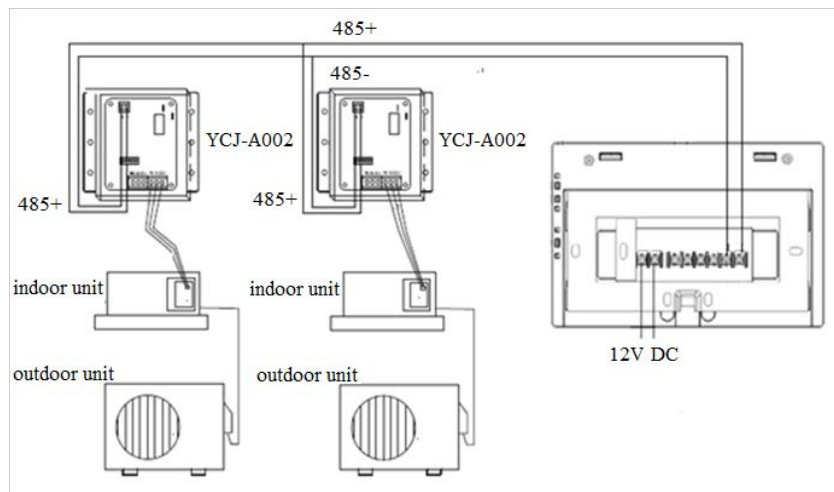

Wiring standards

All of the communication cables between each module and terminal module to the central controller are double core shielded twisted-pair cable. Specific wiring as the table below.

The length of signal line	Wiring dimension
≤ 100	$0.3 \text{ mm}^2 \times 2$
$100 < x \leq 200$	$0.5 \text{ mm}^2 \times 2$
$200 < x \leq 300$	$0.75 \text{ mm}^2 \times 2$
$300 < x \leq 400$	$1.25 \times 2 \text{ mm}^2 \times 2$
$400 < x \leq 500$	$2 \times 2 \text{ mm}^2 \times 2$

Installation

Installation condition

Don't install in the place where it is easy to produce noise.

It will be unavailable if it is installed near to the computer, auto-door, elevator, or other equipments what can produce noise.

Don't install in the place where it is wet or shake violent.

It will cause failure if you install in the place where is very wet or shake violent.

Don't install in the place where it is by direct sunlight or near to the heat.

It will cause failure if you install in the place by direct sunlight or near to the heat.

First, fix the rack on the cassette on the wall. Use A and B two holes if it is 120 cassette, use A and C two holes if it is 86 cassette.

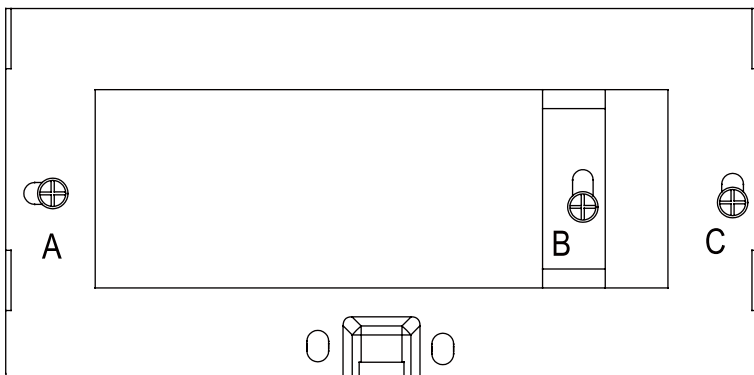

There are two pothooks on each side of the rack. There are four recesses corresponding with the pothooks on the back of the central controller.

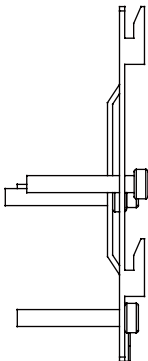

Installation

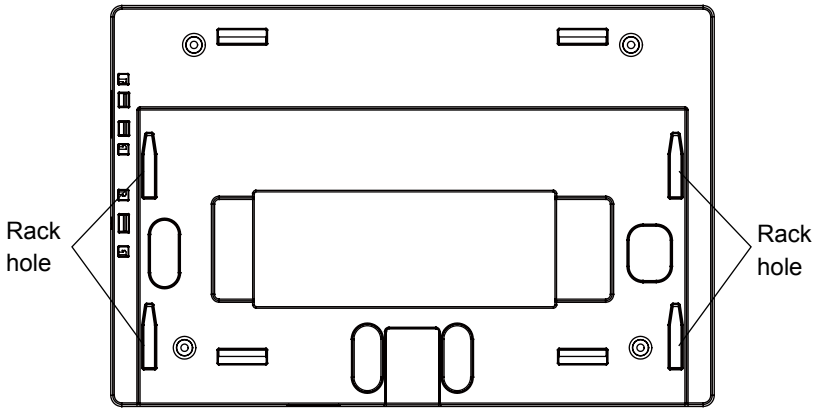

The installation of power adapter

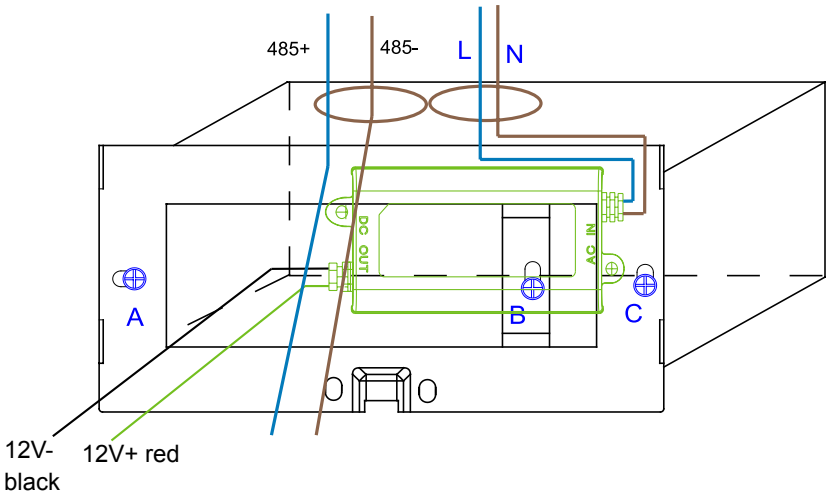

Put the power adapter into the cassette and fix the rack. Put the line of secondary power adapter and the 485 line of converter board out of the rack, and set on the central controller. Then fix the central controller on the rack.

Installation

Wiring between power adapter and central controller

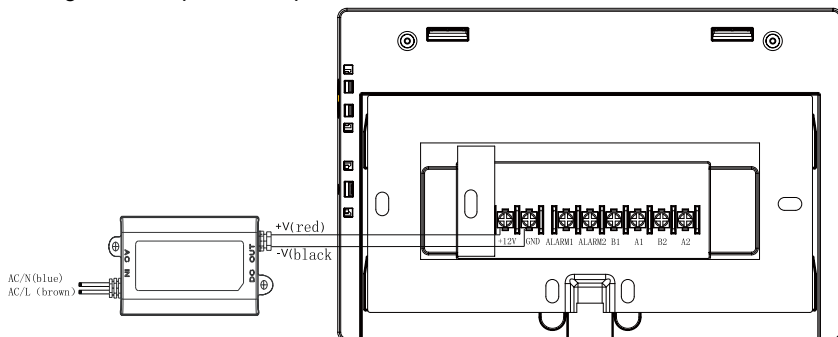

After connection, put the central controller on the rack

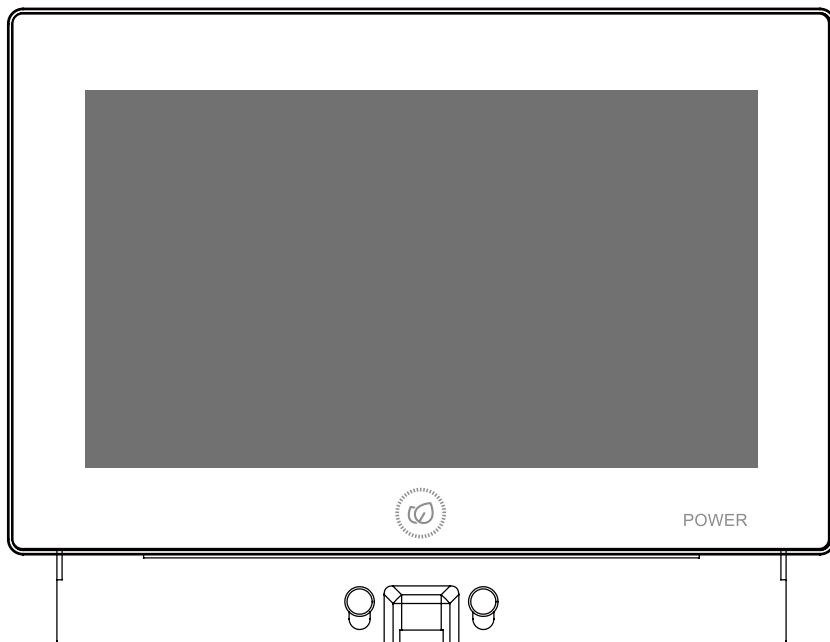

Aim the central controller recesses at pothook, and fix from top to bottom. Then the installation is complete.

