

Installation and maintenance manual
Manuel d'installation et de maintenance
Installations- und Wartungshandbuch
Manuale di installazione e di manutenzione
Manual de instalación y de mantenimiento

Aqu@Scop HT Split

12-6 ÷ 18-9



English

Français

Deutsch

Italiano

Español



12
↓
17.9kW



Air-water Heat Pump

Pompe à Chaleur air-eau

Wärmepumpe Luft-Wasser

Pompa di Calore aria-acqua

Bomba de Calor aire-agua

IOM PAC HT S 01-N-4GB

Part number / Code / Teil Nummer / Codice / Código : **3990662GB**

Supersedes / Annule et remplace / Annulliert und ersetzt /

Annulla e sostituisce / Anula y sustituye : **IOM PAC HT S 01-N-3GB**



INSTALLATION INSTRUCTION

NOTICE D'INSTALLATION

INSTALLATIONSHANDBUCH

ISTRUZIONI INSTALLAZIONE

INSTRUCCIONES DE INSTALACIÓN

English

Français

Deutsch

Italiano

Español

CONTENTS

1. GENERAL RECOMMENDATIONS	3
1.1. SAFETY DIRECTIONS	3
1.2. WARNING.....	3
1.3. EQUIPEMENT SAFETY DATA	4
2. INSPECTION AND STORAGE	5
3. WARRANTY	5
4. CONTENTS OF PACKAGE	5
5. PRODUCT PRESENTATION	5
6. ACCESSORIES	6
7. DIMENSIONS	6
8. HANDLING	6
8.1. OUTDOOR UNIT.....	6
8.2. INDOOR UNIT	7
8.3. NET WEIGHT.....	7
9. TECHNICAL SPECIFICATIONS	7
9.1. PHYSICAL CHARACTERISTICS	7
9.2. ELECTRICAL CHARACTERISTICS	8
9.3. OPERATING LIMITS	8
9.4. THERMODYNAMIC DOMESTIC HOT WATER PRODUCTION.....	9
10. REFRIGERATION AND HYDRAULIC DIAGRAM	10
11. INSTALLATION	10
11.1. OUTDOOR UNIT.....	10
11.2. INDOOR UNIT	12
12. HYDRAULIC LINKS	13
12.1. GENERAL RECOMMENDATIONS	13
12.2. STANDARD CIRCUITS.....	14
12.3. WATER TREATMENT WARNING.....	20
12.4. CONNECTION TO THE CENTRAL HEATING LOOP	20
12.5. HEAT INSULATION.....	20
12.6. FILLING THE SYSTEM WITH WATER.....	21
12.7. SAFETY VALVE DRAIN CONNECTION	21
12.8. ELECTRONIC FLOW METER	21
12.9. WATER FLOW REGULATION	21
13. REFRIGERANT CONNECTIONS	22
13.1. PIPE LINKS TO BE CREATED ON SITE	22
13.2. PIPE INSULATION (NOT SUPPLIED)	23
13.3. VACUUM OF COOLING PIPES AND INDOOR UNIT	23
14. WIRING DIAGRAM AND LEGEND	24
14.1. WIRING DIAGRAM.....	24
14.2. LEGEND	24
15. ELECTRICAL CONNECTIONS	27
15.1. PHASE SEQUENCE AND CUT-OUT CONTROLLER	27
15.2. PROGRESSIVE START-UP	28
15.3. CONNECTIONS.....	29
16. DOMESTIC HOT WATER	31
16.1. CONNECTION TO THE CENTRAL HEATING LOOP	31
16.2. DOMESTIC HOT WATER PRODUCTION MODES.....	32
16.3. DOMESTIC HOT WATER HEATING FUNCTION ACTIVATION	32
17. IN-LINE ELECTRIC HEATER	33
17.1. ELECTRICAL CONNECTIONS	33
17.2. OPERATING MODE	33
17.3. ELECTRIC HEATER FUNCTION ACTIVATION.....	33
18. BOILER RELIEF	34
18.1. ELECTRICAL CONNECTIONS	34
18.2. OPERATING MODES.....	34
18.3. BOILER RELIEF FUNCTION ACTIVATION	34
19. DUAL ZONE	35
19.1. ELECTRICAL CONNECTIONS	35
19.2. ACTIVATING THE DUAL ZONE FUNCTION	35
19.3. AMBIENCE TERMINAL	35
20. COMMISSIONING	36
20.1. PRE-START CHECK LIST	36
21. STARTING THE APPLIANCE	37
21.1. USER INTERFACE	37
21.2. SIMPLIFIED START-UP PROCEDURE	39
21.3. OPERATING CHECK LIST.....	44
22. FINAL TASKS	45
23. IN CASE OF WARRANTY - MATERIAL RETURN PROCEDURE	45
24. ORDERING SERVICE AND SPARE PARTS ORDER	45
25. MAINTENANCE	46
25.1. SERVICING CHECKLIST	46
25.2. INDOOR UNIT CLEANING.....	47
25.3. OUTDOOR UNIT REFRIGERANT CHARGE RECOVERY	47
26. ALARM LIST AVAILABLE ON THE AQU@SCOP HT SPLIT DISPLAY	48
27. FAULTY DIAGNOSIS GUIDE	55



POWER SUPPLY MUST BE SWITCHED OFF BEFORE STARTING WORK IN THE ELECTRIC CONTROL BOX

1. GENERAL RECOMMENDATIONS

Please read the following safety precautions very carefully before installing the unit.

1.1. SAFETY DIRECTIONS

Follow the safety rules in forces when you are working on your appliance.

The installation, commissioning and maintenance of these units should be performed by qualified personnel having a good knowledge of standards and local regulations, as well as experience of this type of equipment.

This appliance has not been designed for use by persons (including children) with reduced physical, sensorial or mental faculties or by persons without any experience or knowledge of heating systems, unless they act under the safety and supervision of a responsible person or have received prior training concerning the use of the appliance.

Children should be supervised to ensure that they do not play with the appliance.

The unit should be handled using lifting and handling equipment appropriate to the unit's size and weight.

Any wiring produced on site must comply with the corresponding national electrical regulations.

Make sure that the power supply and its frequency are adapted to the required electric current of operation, taking into account specific conditions of the location and the current required for any other appliance connected to the same circuit.

The unit must be EARTHED to avoid any risks caused by insulation defects.

It is forbidden to start any work on the electrical components if water or high humidity is present on the installation site.

1.2. WARNING

Cutoff power supply before starting to work on the appliance.

When making the hydraulic connections, ensure that no impurities are introduced into the pipe work.

The manufacturer declines any responsibility and the warranty becomes void if these instructions are not respected.

If you meet a problem, please call the Technical Department of your area.

If possible, assemble the compulsory or optional accessories before placing the appliance on its final location. (see instructions provided with each accessory).

In order to become fully familiar with the appliance, we suggest to read also our Technical Instructions.

The information contained in these Instructions are subject to modification without advance notice.

1.3. EQUIPEMENT SAFETY DATA

Safety Data	R407C
Toxicity	Low
In contact with skin	Liquid splashes or sprays may cause freeze burns. Unlikely to be hazardous by skin absorption. However, R407C may be slightly irritant and, if liquid, it has a strong degreasing effect. Flush contaminated skin areas with running water. If it comes into contact with fabrics, the liquid refrigerant will cause them to freeze and adhere to the skin. Carefully remove the contaminated clothing since it might adhere to the skin and cause freeze burns. Contact a doctor if the affected skin areas are reddened or irritated.
In contact with eyes	Vapours have no effect. Liquid splashes or sprays may cause freeze burns. In these cases rinse your eyes with running water or with a solution for eye lavages for at least 10 minutes. Immediately contact a doctor.
Ingestion	Very unlikely to occur. If this should be the case, it may cause freeze burns. Never induce vomiting. Keep the patient awake. Make him rinse his mouth with running water and make him drink about 1/4 of a litre. Immediately contact a doctor.
Inhalation	R407C: High concentration levels of its vapours in the air can produce an anaesthetic effect, including the loss of consciousness. Particularly severe exposures may cause heart arrhythmia and sometimes prove to be also fatal. At high concentrations there is a danger of asphyxia due to a reduced oxygen content in the atmosphere. In these cases take the patient to the open air, in a cool place and keep him at rest. Administer oxygen, if required. Apply artificial respiration if breathing has ceased or if it has become irregular. In case of heart failure immediately apply cardiac massage. Immediately contact a doctor.
Further Medical Advice	A symptomatic and supportive therapy is generally suitable. A heart sensitisation has been observed in some cases, as a result of exposures to particularly high concentrations. In the presence of catecholamines (such as for example adrenaline) in the blood flow, it has increased the irregularity of the cardiac rhythm and then caused the heart failure.
Long-term exposure	R407C: A lifetime study which has been conducted on the effects inhalation may have on rats at 50,000 ppm has shown the onset of benign tumours of the testicle. These remarks suggest that there is no danger for human beings if they are exposed to concentrations below the occupational limits or equal to them.
Occupational exposure limits	R407C: Recommended limits: 1,000 ppm v/v 8 hours TWA.
Stability	R407C: Not specified.
Conditions to avoid	Use in the presence of exposed flames, red heat surfaces and high humidity levels.
Hazardous reactions	Possibility of violent reactions with sodium, potassium, barium and other alkaline substances. Incompatible materials: magnesium and all the alloys containing over 2% of magnesium.
Hazardous decomposition products	R407 C: Halogen acids deriving from thermal decomposition and hydrolysis.
General precautions	Avoid the inhalation of high concentrations of vapours. The concentration in the atmosphere shall be kept at the minimum value and anyway below the occupational limits. Since vapours are heavier than air and they tend to stagnate and to build up in closed areas, any opening for ventilation shall be made at the lowest level.
Breathing protection	In case of doubt about the actual concentration, wear breathing apparatus. It should be self-contained and approved by the bodies for safety protection.
Storage Preservation	Refrigerant containers shall be stored in a cool place, away from fire risk, direct sunlight and all heat sources, such as radiators. The maximum temperature shall never exceed 45°C in the storage place.
Protection clothes	Wear boots, safety gloves and glasses or masks for facial protection.
Behaviour in case of leaks or escapes	Never forget to wear protection clothes and breathing apparatus. Isolate the source of the leakage, provided that this operation may be performed in safety conditions. Any small quantity of refrigerant which may have escaped in its liquid state may evaporate provided that the room is well ventilated. In case of a large leakage, ventilate the room immediately. Stop the leakage with sand, earth or any suitable absorbing material. Prevent the liquid refrigerant from flowing into drains, sewers, foundations or absorbing wells since its vapours may create an asphyxiating atmosphere.
Disposal	The best procedure involves recovery and recycle. If this is not possible, the refrigerant shall be given to a plant which is well equipped to destroy and neutralise any acid and toxic by-product which may derive from its disposal.
Combustibility features	R407C: Non flammable in the atmosphere.
Containers	If they are exposed to the fire, they shall be constantly cooled down by water sprays. Containers may explode if they are overheated.
Behaviour in case of fire	In case of fire wear protection clothes and self-contained breathing apparatus.

2. INSPECTION AND STORAGE

At the time of receiving the equipment carefully cross check all the elements against the shipping documents in order to ensure that all the crates and boxes have been received. Inspect all the units for any visible or hidden damage.

In the event of shipping damage, write precise details of the damage on the shipper's delivery note and send immediately a registered letter to the shipper within 48 hours, clearly stating the damage caused. Forward a copy of this letter to the manufacturer or his representative.

Never store or transport the unit upside down. It must be stored indoors, completely protected from rain, snow etc. The unit must not be damaged by changes in the weather (high and low temperatures). Excessively high temperatures (above 60 °C) can harm certain plastic materials and cause permanent damage. Moreover, the performance of certain electrical or electronic components can be impaired.

3. WARRANTY

The units are delivered fully assembled and tested.

Any modification to the units without the manufacturer's prior approval, shall automatically render the warranty null and void.

The following conditions must be respected in order to maintain the validity of the warranty:

- Commissioning shall be performed by specialised technicians from technical services approved by the manufacturer.
- Maintenance shall be performed by technicians trained for this purpose.
- Only Original Equipment spare parts shall be used.
- All the operations listed in the present manual shall be performed within the required time limits.



THE WARRANTY SHALL BE NULL AND VOID IN THE EVENT OF NON-COMPLIANCE WITH ANY OF THE ABOVE CONDITIONS.

4. CONTENTS OF PACKAGE

OUTDOOR UNIT

- 1 **HEAT Pump Aqu@Scop HT Split outdoor unit**
- 1 Documentation pouch
- 4 Anti-vibration pads

INDOOR UNIT

- 1 **HEAT Pump Aqu@Scop HT Split indoor unit**
- Documentation pouch
- 1 Water filter kit
- 1 stop cock

5. PRODUCT PRESENTATION

This range of air/water **Aqu@Scop HT Split** (High Temperature) appliances offers the special feature of producing hot water at 65° C at outdoor temperatures between 0° C and -20° C, while guaranteeing a high COP.

Between 0°C and +42°C, the temperature of the hot water produced varies between 65°C and 55°C for the Heating mode and is maintained at 60°C for the Domestic Hot Water (DHW) mode.

Consequently, this **Aqu@Scop HT Split** system is ideally suited to replace a traditional hot water boiler in producing DHW without alterations to the rest of the system.

This technology uses two-stage compressors connected to a patented refrigeration circuit.

This technology ensures remarkably accurate "capacity supplied/heating needs" matching due to its ability to run each compressor independently. Depending on the demand for heating capacity and the operating temperature of heat emitters (i.e. radiators, etc.) the **Aqu@Scop HT Split** regulator selects either the small or large compressor to operate on its own or in a two-stage mode.

6. ACCESSORIES

- Set of stop cocks with pressure tap
 - Set of 2 flexible pipes (length 1 m)
 - Hydraulic connection kit
 - Sludge pot (decanting filter)
 - Domestic hot water tank (300l)
 - Domestic hot water plate exchanger kits for:
 - ✓ Wall-mounted electric tank (DHW outflow via the bottom)
 - ✓ Floor-mounted electric tank (DHW outflow via the top)
 - Directional valve to be linked to the:
 - ✓ Domestic Hot Water function.
 - ✓ Boiler substitution function
 - ✓ Swimming pool function (with temperature probe kit)
 - 140 litre buffer tank
 - Anti-vibration pads (Anti-vibration mountings)
 - 6kW in-line electric heater
 - Dual zone Under-floor / Radiator heating kit (modulating valve + electric control box + temperature probe)
 - Dual zone management kit for existing valve (electric control box + temperature probe)
 - Wired programmable ambience terminal
 - Wireless programmable ambience terminal
- } Accessory recommended for an optimal functioning**

7. DIMENSIONS

SEE APPENDIX

8. HANDLING

8.1. OUTDOOR UNIT

Take care to avoid any rough handling or impacts when unloading and moving the appliance. Only push or pull the appliance by its base. Place a safety wedge between the unit base and the fork lift truck to avoid damaging the unit's structure and casing.

The handles present on the appliance's panels are intended for the removal/refitting of the latter and must not be used for handling the complete appliance (too heavy to be supported by the panels).

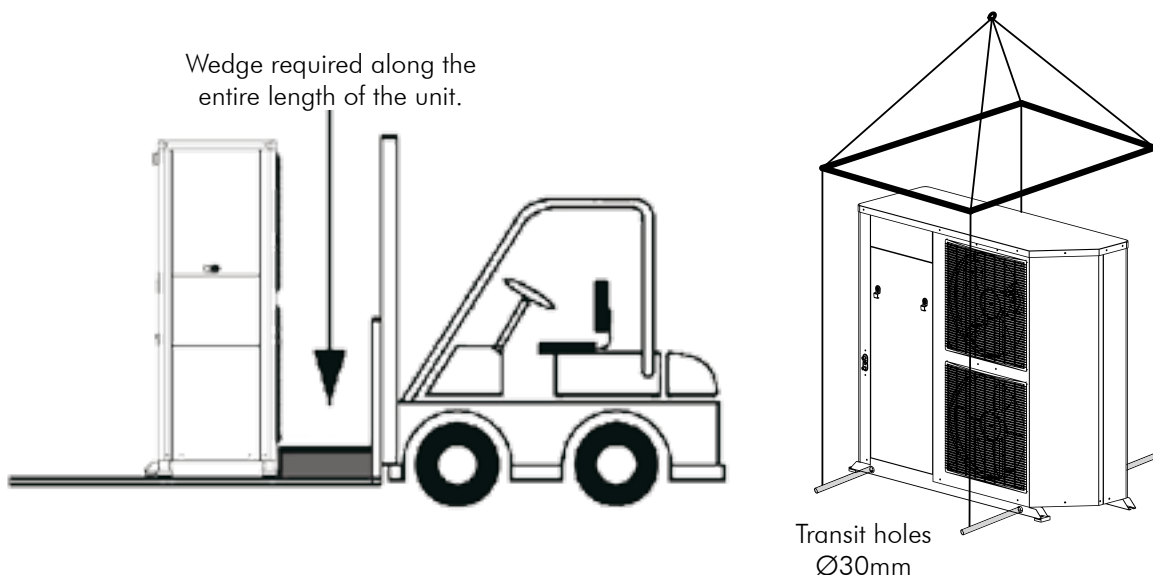

8.2. INDOOR UNIT



NEVER USE THE REFRIGERATING PIPES TO MOVE THE UNIT.

8.3. NET WEIGHT

OUTDOOR UNIT		
12-6	14-7	18-9
184	209	213

INDOOR UNIT	
12-6 / 14-7	18-9
28	30



9. TECHNICAL SPECIFICATIONS

9.1. PHYSICAL CHARACTERISTICS

9.1.1. OUTDOOR UNIT

			12-6	14-7	18-9
REFRIGERANT					
Type			R407C		
Factory charge for links between 0 and 20 metres		g	SEE NAME PLATE		
Additional charge between 20 and 45 metres		g/m	SEE APPENDIX		
LINKING PIPES					
links between 0 and 25 metres	Suction (gas) pipe	inches	5/8		
	Liquid pipe	inches	3/8		
links between 0 and 45 metres	Suction (gas) pipe	inches	3/4		
	Liquid pipe	inches	1/2		
FANS					
Fans (x2)			206W - 700tr/mn - 6000m ³ /h		
ACOUSTIC PRESSURE					
Acoustic pressure – outdoor unit		dB(A)	65	65	65

This equipment contains fluorinated gas with greenhouse gas effects covered by the Kyoto agreement.

9.1.2. INDOOR UNIT

			12-6 / 14-7 *	18-9
LINKING PIPES				
Gas		inches	5/8	
Liquid		inches	3/8	
HYDRAULIC LINKS				
Inlet water		gas	1" Female / Rotating nut	
Outlet water		gas	1" Female / Rotating nut	
WATER FLOW				
Nominal		l/h	1030 / 1230	1480
Minimum		l/h	880 / 1050	1260
Maximum		l/h	1170 / 1390	1670
ACOUSTIC PRESSURE				
Acoustic pressure- indoor unit		dB(A)	41	41

* Outdoor unit common to Indoor units 12-6 and 14-7

9.2. ELECTRICAL CHARACTERISTICS

9.2.1. OUTDOOR UNIT

		12-6	14-7	18-9
SUPPLY VOLTAGE		400V / 3 Ph / 50Hz		
Start-up current draw with limiter	A	< 60		
Maximum current				
Only outdoor unit	A	12.2	13.2	15.2
Outdoor unit + indoor unit + accessories*	A	15.5	16.5	18.5
SUPPLY VOLTAGE		230V / 1 Ph / 50Hz		
Start-up current draw with limiter	A	< 45		
Maximum current				
Only outdoor unit	A	25.7	27.2	/
Outdoor unit + indoor unit + accessories*	A	29	30.5	/

* Depending on the installation configuration, the power supply to the Indoor unit can either be separate or routed via the Outdoor unit (single master unit circuit protection).

9.2.2. INDOOR UNIT

		12-6 / 14-7	18-9
SUPPLY VOLTAGE		230V / 1 Ph / 50Hz	
Maximum current			
Only indoor unit	A	1.8	
Indoor unit + accessories	A	3.3	

9.3. OPERATING LIMITS

Aqu@Scop HT Split appliances are equipped with a 2-stage output system with a ratio of 1:2.

When heating needs are low and when the required outlet water temperature is below 55° C, only the first stage is used at reduced capacity until the temperature balance point is reached. In other cases, the **Aqu@Scop HT Split** operates at full capacity to supply heating needs until the chosen balance point is reached.

The outlet water temperature is automatically adjusted to the water rule (heating curve) up to a maximum temperature of 65° C.

SINGLE /TWO STAGE OPERATING LIMITATIONS

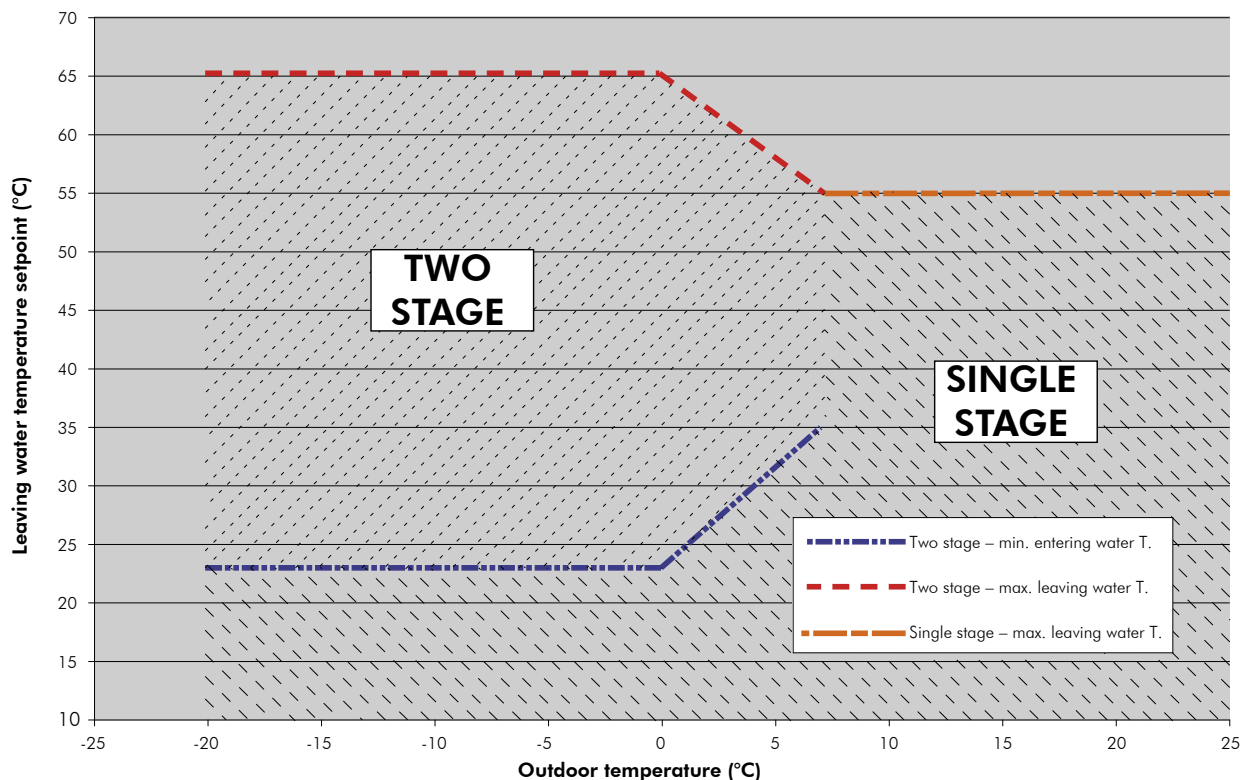

9.4. THERMODYNAMIC DOMESTIC HOT WATER PRODUCTION

9.4.1. PERFORMANCE

		12-6			
Configuration		C2 Compressor		C1+C2 Compressor	
Outdoor temp.	°C	40	7	0	-10
PAC max. outlet temp.	°C	60	60	65	65
Average capacity	kW	9	5.5	10.6	9.3
DHW temperature	°C	56	58	58	58
Time [min] Initial temperature: 15°C	min	97	163	85	98
Time [min] Initial temperature: 35°C	min	49	87	45	53

		14-7			
Configuration		C2 Compressor		C1+C2 Compressor	
Outdoor temp.	°C	40	7	0	-10
PAC max. outlet temp.	°C	60	60	65	65
Average capacity	kW	11	7.1	13.6	12
DHW temperature	°C	54	57	56	57
Time [min] Initial temperature: 15°C	min	72	124	63	73
Time [min] Initial temperature: 35°C	min	35	65	32	38

		18-9			
Configuration		C2 Compressor		C1+C2 Compressor	
Outdoor temp.	°C	40	7	0	-10
PAC max. outlet temp.	°C	60	60	65	65
Average capacity	kW	13.3	8.3	16	14.1
DHW temperature	°C	53	56	55	56
Time [min] Initial temperature: 15°C	min	60	103	52	61
Time [min] Initial temperature: 35°C	min	28	53	26	31

Tank capacity: 300l



The above performance figures are stated for a system with the Domestic Hot Water tank accessory.

The tank is equipped with a 2.5kW back-up heating element for single or three phase connection. The performances obtained and stated in the above table are without back-up heating. For higher domestic hot water temperatures or for Legionnaires disease protection treatment, the use of the back-up electric heating resistances is required.

9.4.2. PRESSURE LOSS

DHW TANK 300l

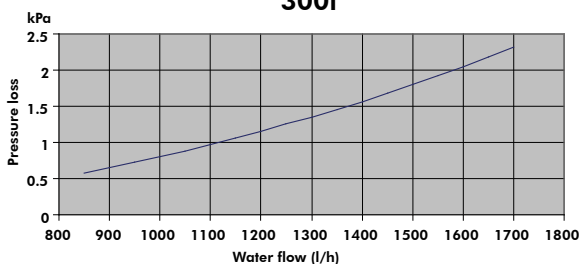

3-WAY-VALVE HEATING/DHW

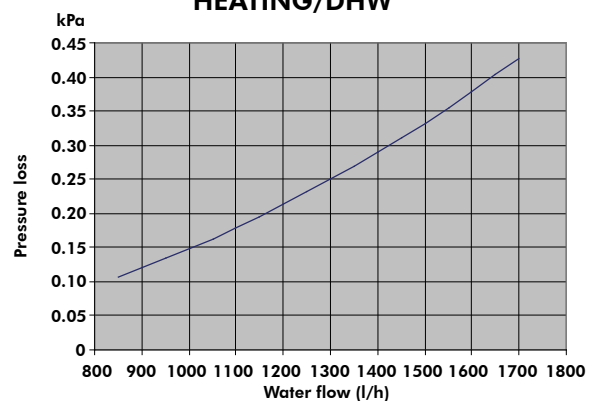

10. REFRIGERATION AND HYDRAULIC DIAGRAM

SEE APPENDIX

11. INSTALLATION



The unit is not designed to withstand weights or stresses from adjacent equipment, pipe work or constructions. Any foreign weight or stress on the unit structure could lead to a malfunction or a collapse with dangerous consequences for personnel and property. In such an event, the warranty shall be null and void.

11.1. OUTDOOR UNIT

11.1.1. SITING THE INSTALLATION

The outdoor unit must be installed outdoors with sufficient surrounding clearance to enable unobstructed air circulation through the appliance and access for maintenance work.

11.1.1.1. PREVAILING WIND

In the case of the unit being sited in areas exposed to high winds, you must avoid the wind hitting the fan blowing surface areas directly to avoid any risk of recycling cooled air. Exchanger fan operation can be disrupted by strong winds, which can cause de-icing problems and fan malfunctions.



Unit operation depends on air temperature. Any recycling of air extracted by the fan lowers the air intake temperature across the exchanger fins and alters the standard operating conditions.

The arrows show the direction of air circulation through the appliance. (Refer to Fig. § Floor location).

11.1.1.2. CONDENSATE WATER MANAGEMENT

Depending on temperature and outdoor air humidity conditions, water vapour contained in the air can condense on the finned heat exchanger and even form ice under low outdoor temperature conditions (around $< 5^{\circ}\text{C}$). This condensate water and defrosted water runs off via outlets provided under the exchanger. To aid water run-off and avoid frozen water remaining in the appliance in winter, we recommend that it is mounted at a height of around 10cm off the ground by installing the ant-vibration mounting kit. In this way, condensate and defrosted water can run off freely and be absorbed into the ground or channelled to a basin built under the appliance in order to protect the environment.

In areas where outdoor temperatures fall below 1°C , the system can be equipped with a condensate anti-freeze protection system (e.g. a heated pipe sheath, Not supplied).

11.1.1.3. HOW TO REDUCE NOISE POLLUTION

In order to contain noise levels, we equip our appliances with quiet fans and encase the technical compartment in sound-proofed panels. However, noise levels can be reduced even further by following a few installation precautions:

- Do not install the appliance near a bedroom window. Avoid locating the appliance in a corner (increased reverberated noise).
- Install the rubber pads supplied or anti-vibration pads (available as an option) under the appliance.
- Do not join the concrete slab supporting the appliance to the structure of the dwelling (structure-borne noise transmission).

11.1.2. CLEARANCE

When choosing the location for the appliance, take care to leave sufficient free clearance on all sides to ensure easy access for maintenance work. The minimum free clearance dimensions indicated must be observed to ensure both proper system operation and allow access for maintenance and cleaning.

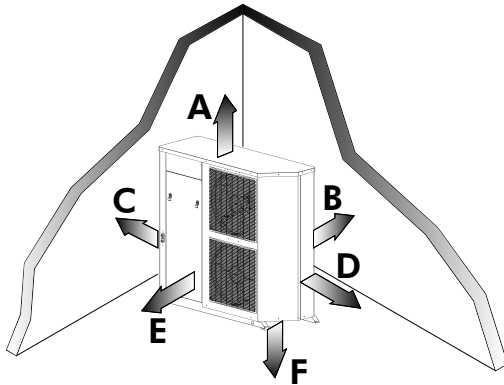

REF.	DIMENSION
A	800mm
B	500mm
C	500mm
D	400mm
E	800mm
F	100mm

11.1.3. ATTACHEMENT TO THE GROUND

The appliance must be sited on a level and solid floor and preferably on a masonry surface.

Unit mounting measurements are shown on the drawing opposite. A slope of 1 cm/m should be created to assist rainwater drainage.

Vibration dampers must be fitted during installation to overcome any risks of vibration being transmitted due to direct contact with a rigid support surface.

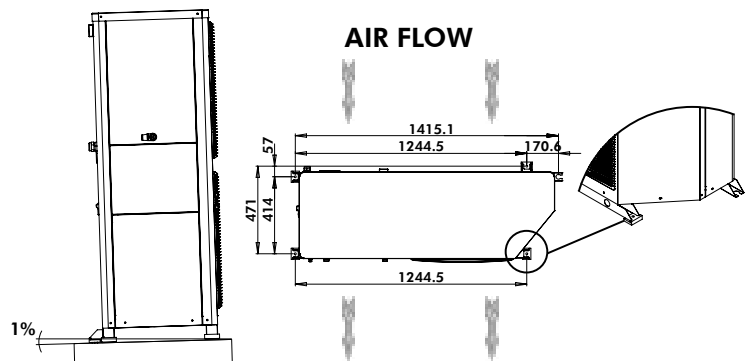

THE UNIT MUST NEVER BE INSTALLED ON A WALL BRACKET.

11.1.3.1. MOUNTING WITH ANTI-VIBRATION SUPPORTS

ANGLED FEET

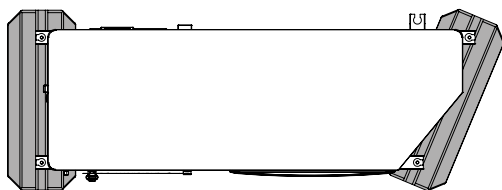
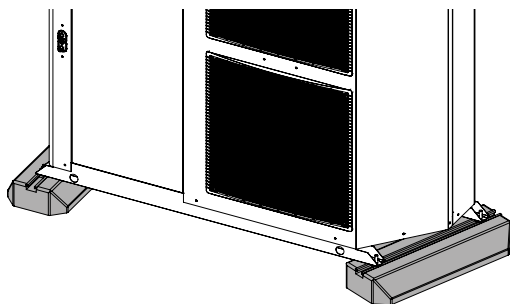

PARALLEL FEET

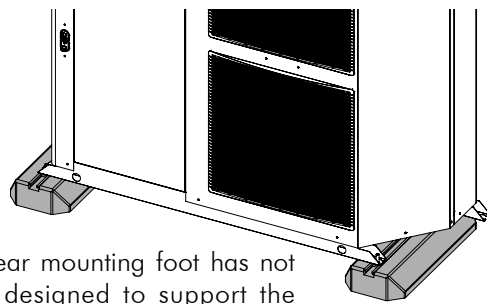

THE REAR FOOT MUST BE USED IN ACCORDANCE WITH THE ASSEMBLY ILLUSTRATED BELOW.

11.2. INDOOR UNIT

11.2.1. SITING THE INSTALLATION

The unit has been designed for indoor applications and must be sited in a location protected from bad weather and without any risk of freezing during winter months. The premises must be clean, dry and properly ventilated.

If there is a possibility of the indoor temperature falling below 1°C, you must take every precaution to provide anti-freeze protection for the hydraulic circuit (addition of mono-propylene glycol).

When choosing the location for the appliance, take care to leave sufficient free clearance all around to ensure easy access for maintenance work. These minimum free clearance dimensions around the appliance should be maintained in order to provide access to the unit.

11.2.2. CLEARANCE

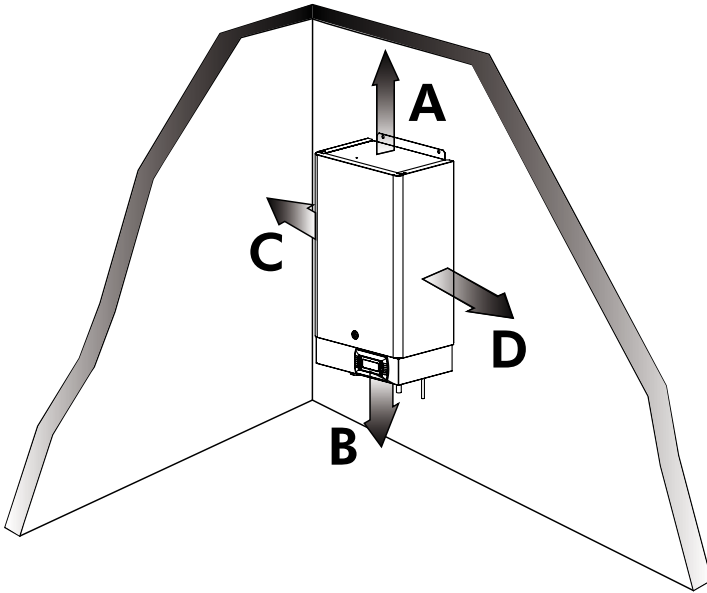

REF.	DIMENSION
A	150
B	1160
C	100
D	100

11.2.3. WALL-MOUNTING

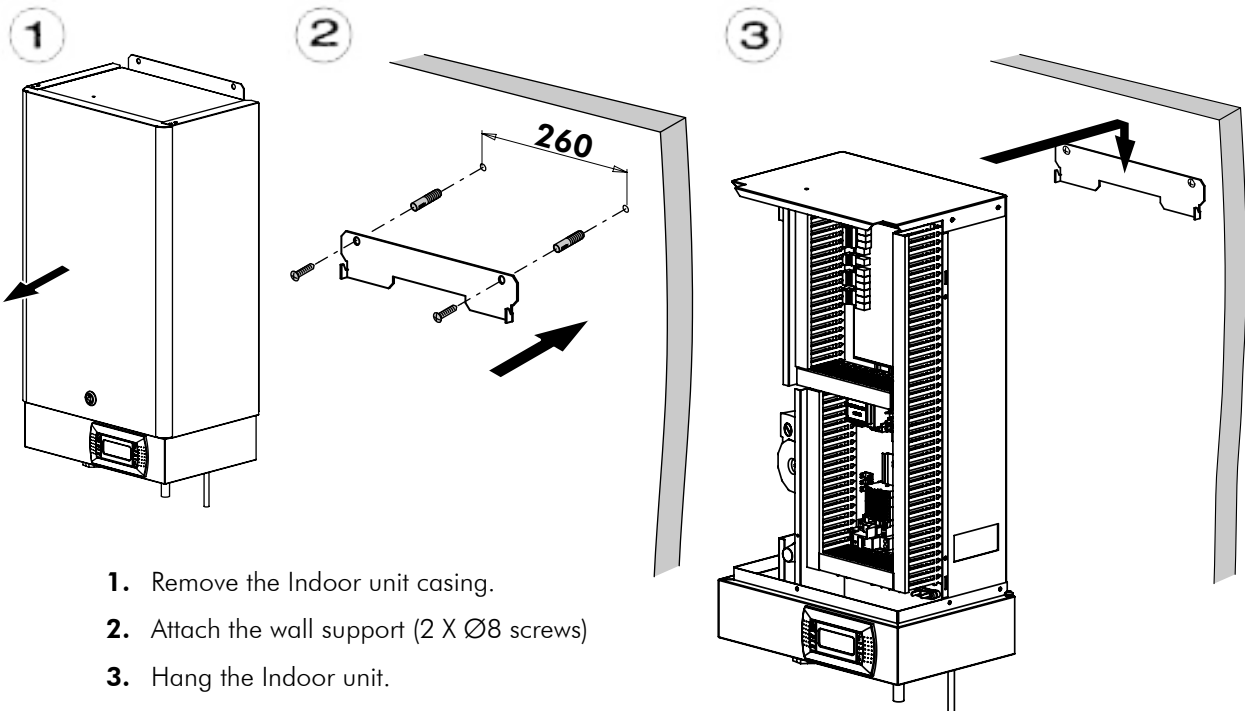

1. Remove the Indoor unit casing.
2. Attach the wall support (2 X Ø8 screws)
3. Hang the Indoor unit.



NEVER USE THE REFRIGERATING PIPES TO MOVE THE UNIT.

12. HYDRAULIC LINKS

When choosing and installing water pipes, you must consult and observe all current local standards, regulations and instructions.

12.1. GENERAL RECOMMENDATIONS

You must design the pipe network with the minimum number of bends and keep the number of changes in height to the strict minimum. This will reduce installation costs and ensure optimum system performance. The pipe network must include:

- A vibration elimination system (e.g.: link hoses available as an accessory) on all pipes connected to the appliance in order to reduce vibrations and noise transmitted to the building fabric.
- Stop cocks to isolate the hydraulic circuit during maintenance.
- Manual or automatic bleed valves at the highest point on the water circuit.
- A suitable system for maintaining water pressure in the circuit (expansion tank).
- The installation of thermometers and pressure gauges on the heat exchanger inlet and outlet to facilitate day-to-day controls and system maintenance.

12.1.1. ANTI-CLOGGING PROTECTION

To avoid any risk of foreign bodies entering the appliance and to guarantee operating performance, WE STRONGLY RECOMMEND THAT YOU INSTALL THE WATER FILTER ACCESSORY on the Indoor unit inlet pipe.

When installing **Aqu@Scop HT Split** appliances in existing water circuits, a sludge trap and a removable mesh filter should be installed upstream of the appliance.

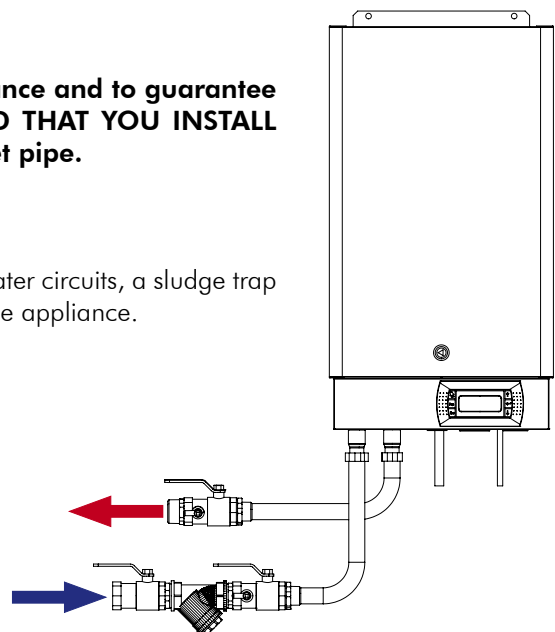

12.1.2. MINIMUM HEATED WATER VOLUME REQUIREMENTS – BUFFER TANK.

To ensure that the system operates correctly you must use suitably sized and properly routed pipes for the hydraulic links between the Heat pump and the mains network.

The volume of water contained in the installation must be sufficient to avoid any possibility of the compressor "short cycling", and to guarantee adequate compressor running times in order to provide optimum service life and to ensure that de-icing cycles are performed properly. To ensure the **Aqu@Scop HT Split** functions efficiently, available installation water volume must be:



200l < available water volume < 250l

When water circulation through heat emitters can be interrupted (thermostatic radiator valves closed) or the heating supply halted, you must ensure that:

- The heat pump maintains its nominal water flow,
- The heat pump operates in a loop with a minimum available volume of 200 litres.

The use of a 3-speed circulation pump enables water flow through the appliance to be adapted to pressure losses in the system. (Pump supplied set on Max position).

12.2. STANDARD CIRCUITS

12.2.1. AQU@SCOP HT SPLIT ONLY

Layout 1: Application without room by room regulation

This layout is recommended when the **Aqu@Scop HT Split** water flow is continuous and close to the nominal value (**no thermostatic valves**).

The buffer tank (2) provides extra circulating water volume to maintain the minimum volume.

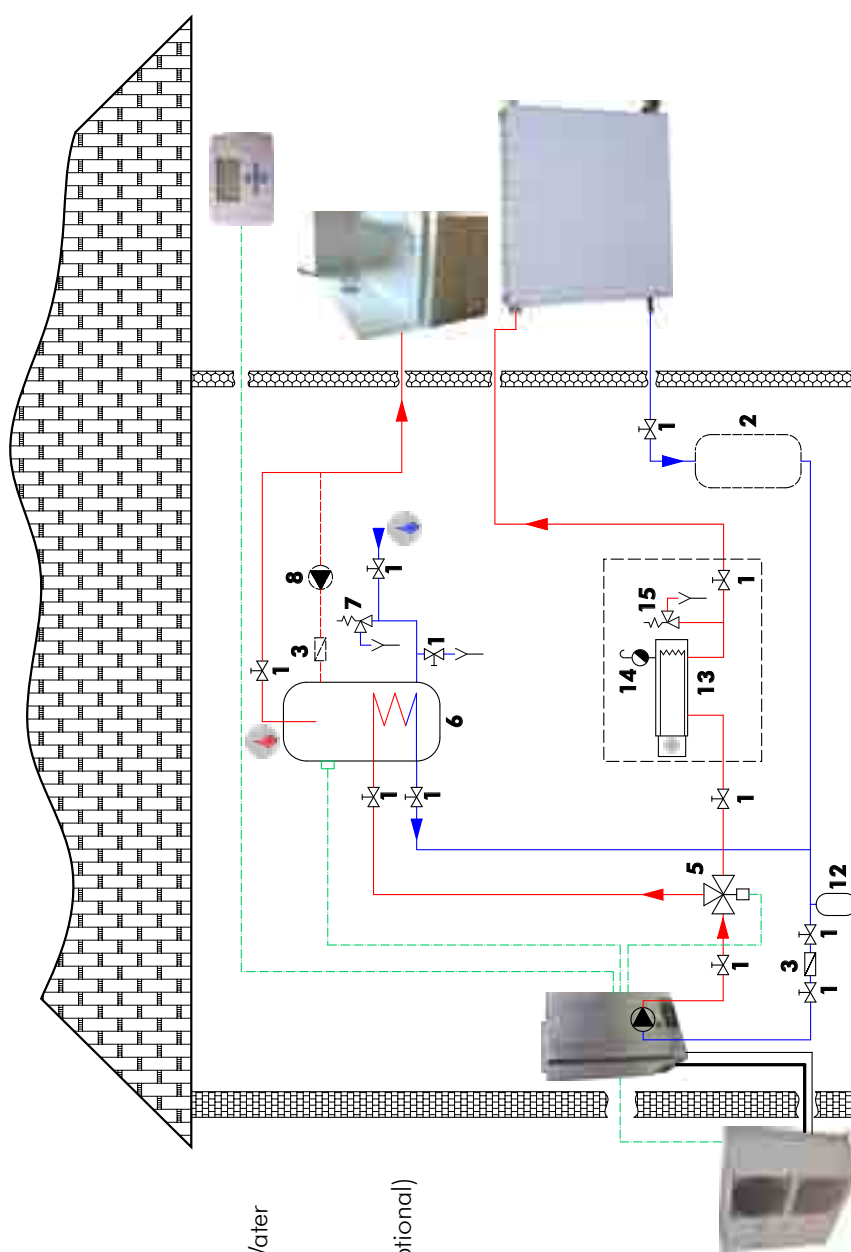

1. Stop cocks
2. Buffer tank (optional)
3. Filter or sludge trap
4. Relief valve
5. 3-way valve – Domestic Hot Water
6. Domestic Hot Water tank
7. Safety devices
8. Recycling circulation pump (optional)
12. Expansion tank
13. In-line heater
14. Bleed
15. Safety valve

Layout 2: Application with room by room regulation

This layout is recommended for heating installations with wide operating water flow variations (radiator thermostatic valves present in the system). We strongly recommend including the buffer tank (2) as it guarantees that the heating loop capacity is higher than the minimum volume when the maximum number of thermostatic valves are closed.

The flow regulating valve (11) is used to balance the flow in heating mode and domestic hot water production mode to always ensure optimum **Aqu@Scop HT Split** operation.

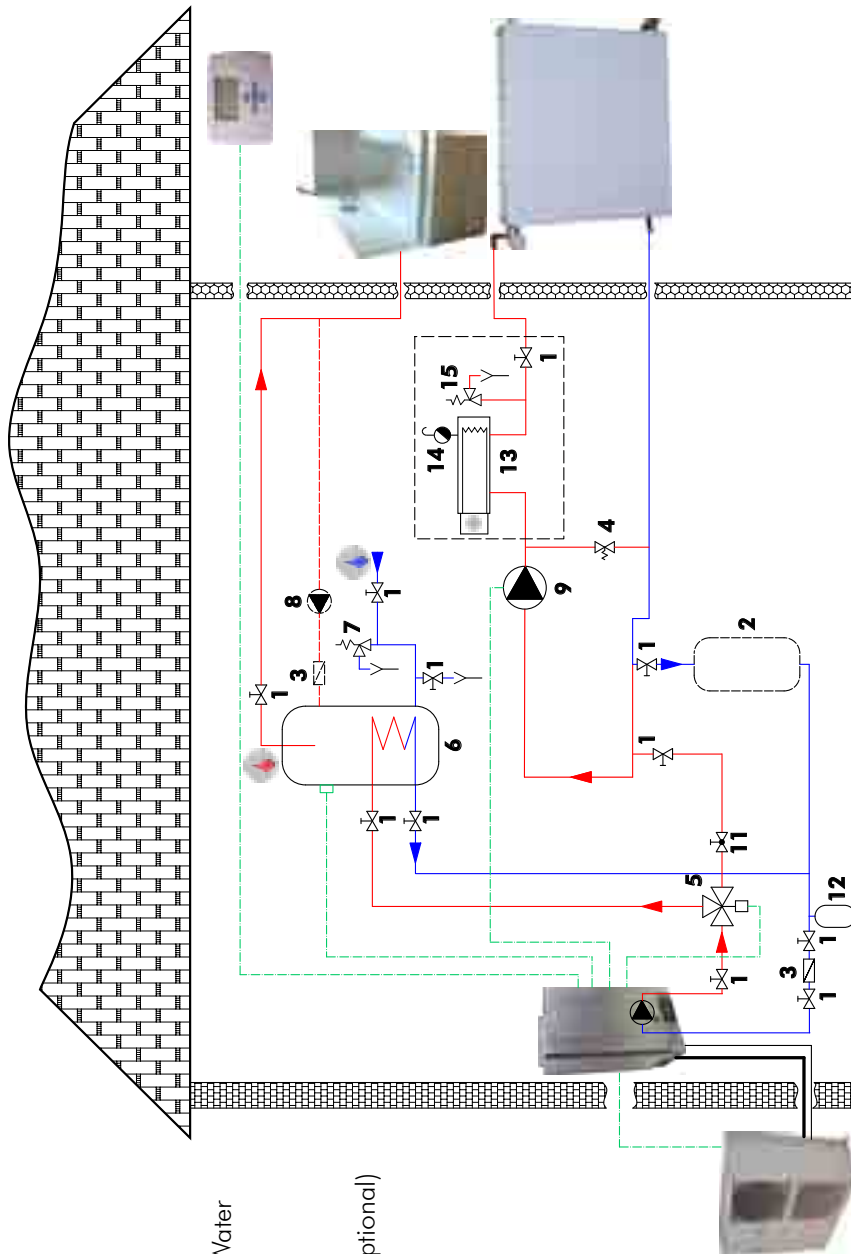

1. Stop cocks
2. Buffer tank (optional)
3. Filter or sludge trap
4. Relief valve
5. 3-way valve – Domestic Hot Water
6. Domestic Hot Water tank
7. Safety devices
8. Recycling circulation pump (optional)
9. Circulation pump
11. Flow regulating valve
12. Expansion tank
13. In-line heater
14. Bleed
15. Safety valve

Layout 3: Application with room by room regulation

This layout is also recommended for heating installations with wide operating water flow variations (radiator thermostatic valves present in the system). Minimum system volume is guaranteed by a mixing tank (10). Take care when calculating the volume of water in the installation and only take account of 50% of the mixing tank's volume.

Example: For a useful volume of 100 litres the actual mixing tank volume will be 200 litres.

The flow regulating valve (11) is used to balance the flow in heating mode and domestic hot water production mode to always ensure optimum **Aqu@Scop HT Split** operation.

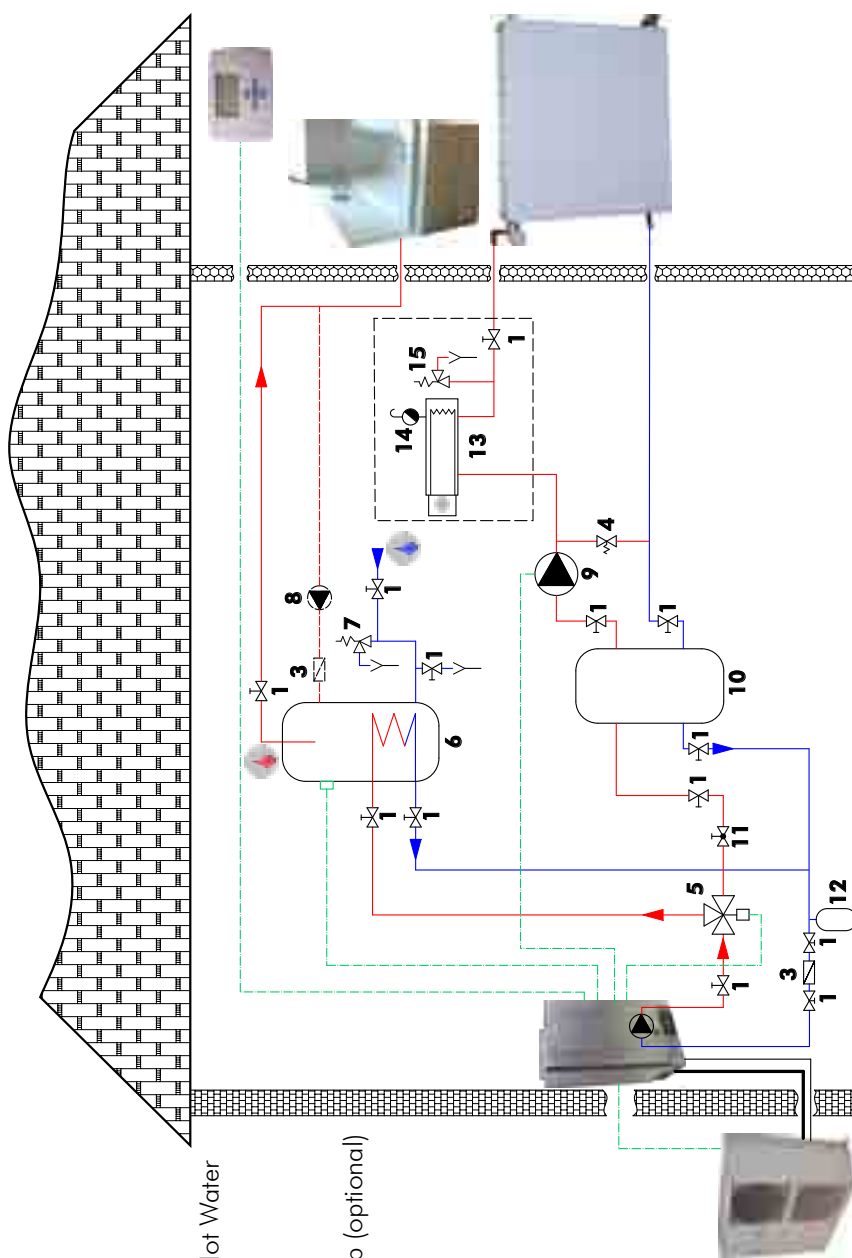

- 1. Stop cocks
- 3. Filter or sludge trap
- 4. Relief valve
- 5. 3-way valve – Domestic Hot Water
- 6. Domestic Hot Water tank
- 7. Safety devices
- 8. Recycling circulation pump (optional)
- 9. Circulation pump
- 10. Mixing tank
- 11. Flow regulating valve
- 12. Expansion tank
- 13. In-line heater
- 14. Bleed
- 15. Safety valve

Layout 4: Domestic Hot Water (DHW) production by way of the plate exchanger kit for fitment on the existing DHW tank

Example for a wall-mounted tank (DHW outflow via the bottom)

A different kit is required for a floor-mounted tank (DHW outflow via the top). Please refer to the corresponding documentation.

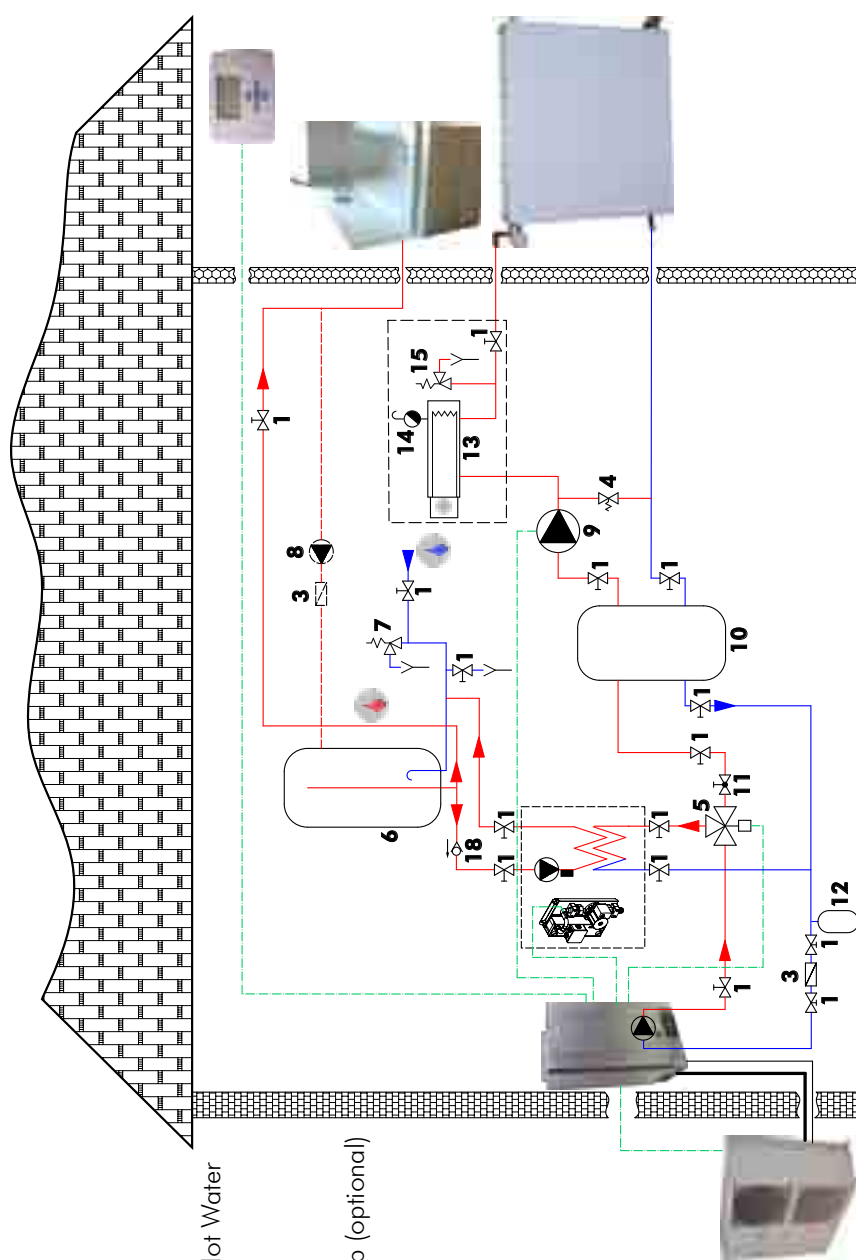

- 1. Stop cocks
- 3. Filter or sludge trap
- 4. Relief valve
- 5. 3-way valve – Domestic Hot Water
- 6. Domestic Hot Water tank
- 7. Safety devices
- 8. Recycling circulation pump (optional)
- 9. Circulation pump
- 10. Mixing tank
- 11. Flow regulating valve
- 12. Expansion tank
- 13. In-line heater
- 14. Bleed
- 15. Safety valve
- 18. Non-return valve

12.2.2. AQU@SCOP HT SPLIT AS A BOILER SUBSTITUTE

We recommend the fitting of a zone valve to avoid heat losses via the boiler when the **Aqu@Scop HT Split** is working on its own.

All system devices should be of a suitable size to limit pressure losses.

Water flow within the heating circuit is normally driven by the circulation pump already present in the installation (recommended solution) or by the **Aqu@Scop HT Split's** circulation pump. In this case, you must ensure that the circulation pump generates sufficient water pressure.

There is no need to replace the existing buffer tank on the circuit to take account of the small volume of water added by the presence of the **Aqu@Scop HT Split**.

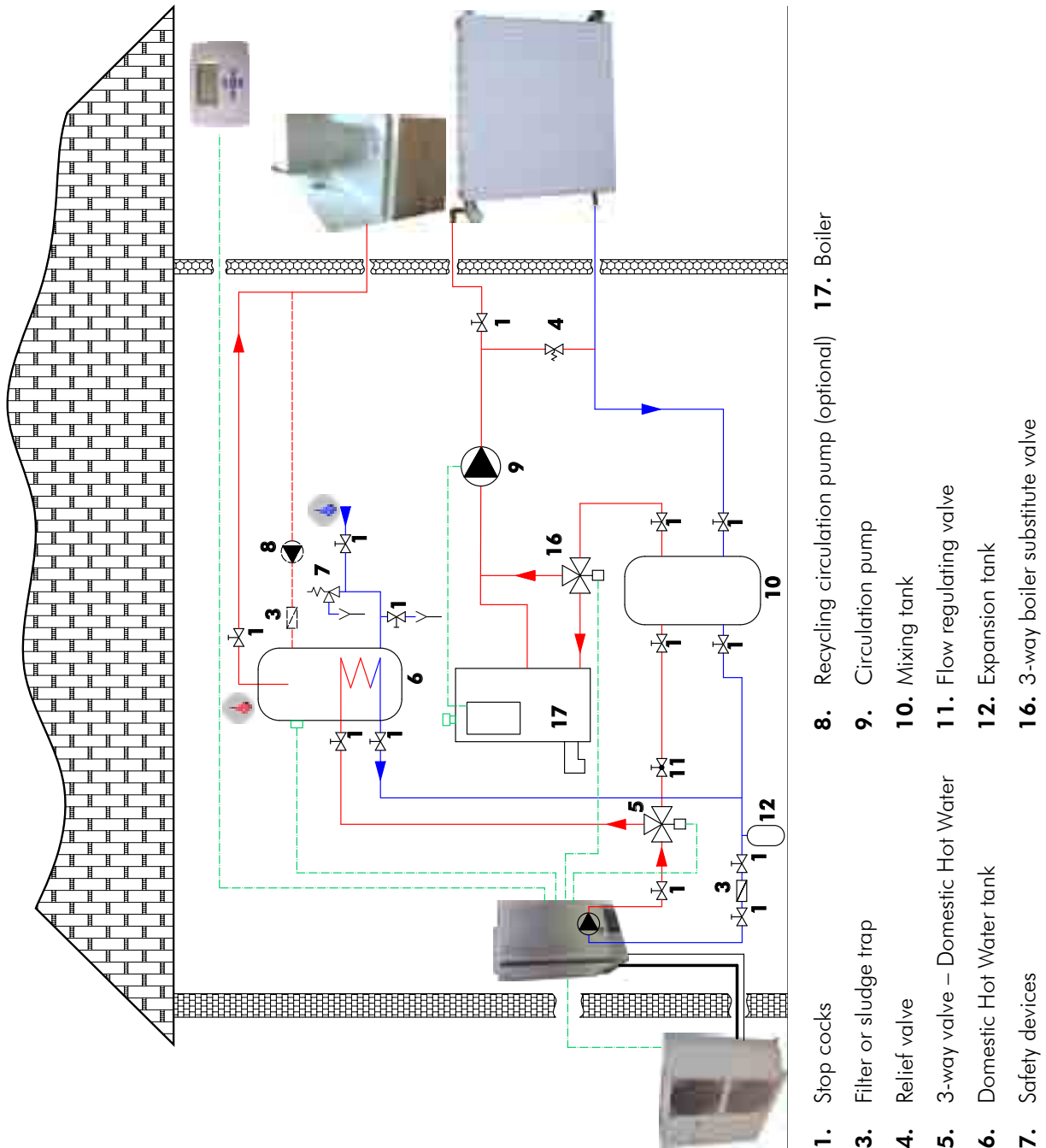

IMPORTANT: the hydraulic kit available as an option enables you to prepare the circuit for connection to the **Aqu@Scop HT Split** in accordance with our recommendations. The hydraulic kit is available with or without zone valves.

DO NOT FIT A BOILER SUBSTITUTE VALVE



- WALL-MOUNTED GAS-FIRED BOILER with domestic hot water production and a single circulation pump used for both heating and domestic hot water.
- BOILER with a circulation pump.

12.2.3. AQU@SCOP HT SPLIT – DUAL ZONE INSTALLATION (UNDER-FLOOR HEATING + RADIATORS)

The **Aqu@Scop HT Split** manages a radiator zone (high temperature, zone 2) and an under-floor heating zone (low temperature, zone 1) by way of an under-floor temperature outlet probe, a modulating 3-way valve (230V 3 phase motor) and a water circulation pump for each zone.

Each zone can be controlled by a dedicated ambience terminal, which then enables the **Aqu@Scop HT Split** to manage 2 independent water laws. When the radiators zone is not in operation, the **Aqu@Scop HT Split** switches over automatically to the under-floor heating water law, and thereby optimises the seasonal COP for the entire installation.

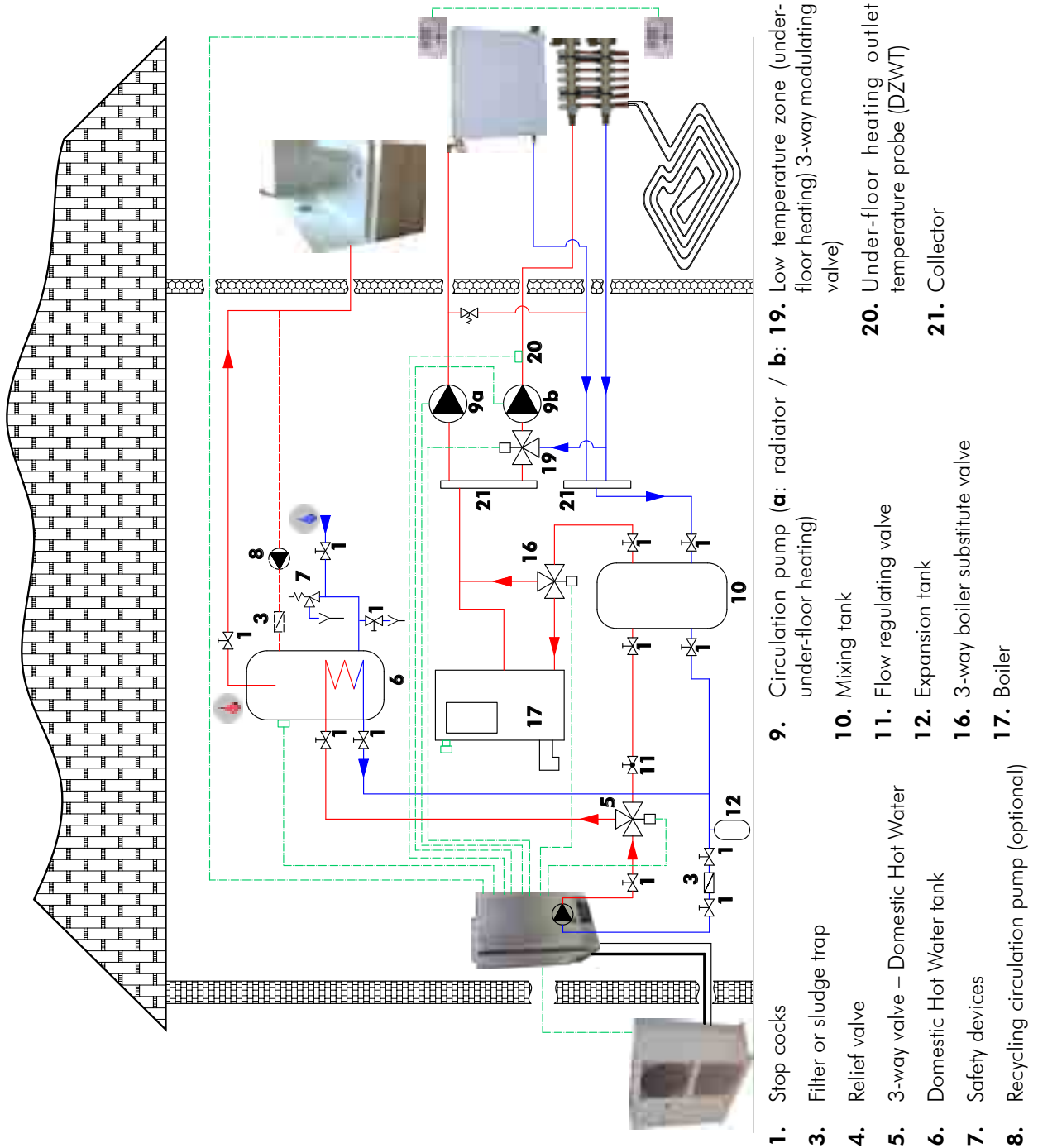

12.3. WATER TREATMENT WARNING

Using untreated or inadequately treated water in this appliance can lead to a build-up of limescale, algae or sludge deposits and cause corrosion and erosion. As the manufacturer is not aware of the components used in the hydraulic network, or of the quality of water used, the installer or the owner should contact a specialised water treatment company. This issue is particularly important and every care should be taken to ensure that circuit water is properly treated in order to avoid problems associated with incorrect water distribution. A clogged water network will systematically lead to premature wear of the appliance's components.

12.4. CONNECTION TO THE CENTRAL HEATING LOOP

You must check water tightness and the cleanliness of the installation before connecting the **Aqu@Scop HT Split**.

For the **Aqu@Scop HT Split**'s WATER INLET and OUTLET connections, you must install manual stop cocks with the same diameter as the main pipe work. This will enable maintenance work to be carried out on the **Aqu@Scop HT Split** without having to bleed the entire system.

A link valve with pressure tap kit is available.

The **Aqu@Scop HT Split** must be protected by a water filter. When connecting this device to the **Aqu@Scop HT Split**, take care to keep the water filter sieve pointing downwards. A sludge trap should be fitted in the event of high sludge build-ups.



AN EXPANSION TANK ADAPTED TO THE VOLUME OF WATER IN THE INSTALLATION MUST BE INSTALLED.

It is important to ensure that the mains water supply pressure is sufficient to fill the installation.



THE MANUFACTURER'S WARRANTY IS VOID IF THE FILTER SUPPLIED WITH THE Aqu@Scop HT Split IS NOT INSTALLED TO PROTECT THE APPLIANCE

WARNING!

Take care not to damage the hydraulic pipe links by applying too much tightening pressure. Use a second wrench to compensate for the tightening torque.

You should always use a counter-wrench for tightening valves.

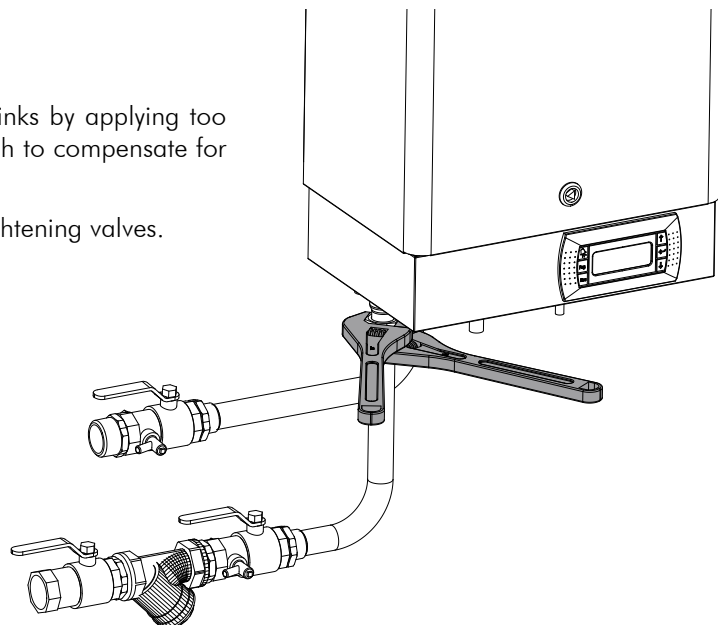

12.5. HEAT INSULATION

To guarantee proper energy efficiency and compliance with current standards, water pipes passing through uninhabited zones should be properly lagged to retain heat.

To achieve correct insulation with conductivity of 0.04 W/mK, lag the pipes with insulating material with a radial thickness between 25mm and 30 mm.

12.6. FILLING THE SYSTEM WITH WATER

Once the installation is complete and after having clean and rinsed out the circuit network, you must fill the water circuit in accordance with current professional standards until you obtain the service pressure which will be:

0.5 bar < P. service < 2.5 bars.

The **Aqu@Scop HT Split** is equipped with an electronic water pressure sensor. This can be viewed on the main P1 screen on the display, as well as on the Maintenance screens.

The water supply should come either from the mains network or from the Heat Pump or from any other point on the installation.

Check that the automatic bleed valve operates correctly.

You must completely bleed the circuit of all air to ensure efficient operation.

Close the inlet water valve once the hydraulic circuit is filled correctly.

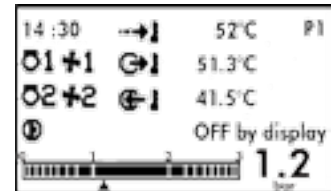

12.7. SAFETY VALVE DRAIN CONNECTION

The safety valve is equipped with a drain pipe. In the event of abnormally high heating circuit pressure (overheating, inadequate expansion tank water volume, faulty expansion tank, continuous filling...), water can be drained off via the valve. At the time of installation, you must ensure that these water discharges present no risk to the user. If necessary, connect the drain pipe to the waste water network via a siphon incorporating an opening to view proper water drainage.

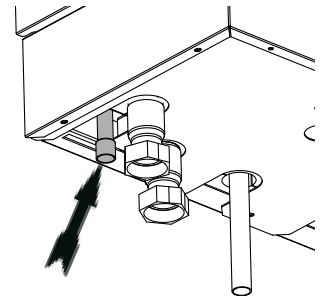

12.8. ELECTRONIC FLOW METER

The condenser water circuit is equipped with a vortex effect electronic flow meter. This device provides real-time readings of the installation's water flow and reassurance that this flow is adequate before starting the unit.

The appliance is also equipped with a group of safety devices including a valve set at 3 bars, and a manual relief valve.

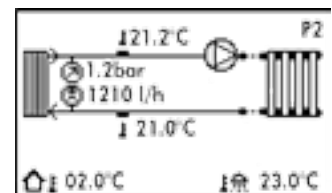

12.9. WATER FLOW REGULATION

Water flow can be viewed on screen P2 as well as on the Maintenance screens.

In relation to circuit pressure losses, use the water circulation pump speed selector to adjust the flow on the unit to correspond as closely as possible to the recommended nominal flow (Refer to the § **PHYSICAL CHARACTERISTICS**, page 7)

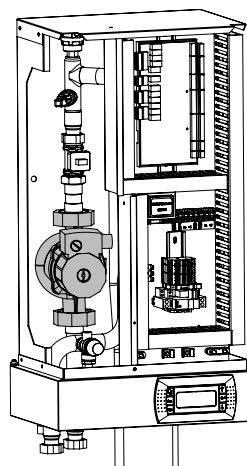

13. REFRIGERANT CONNECTIONS

13.1. PIPE LINKS TO BE CREATED ON SITE

This work must be performed by qualified personnel in accordance with the best heating and air conditioning engineering practices (brazing, vacuum draining, filling, etc.).

- Only use refrigeration quality copper pipe.
- Use anti-vibration collars for attaching pipe work to the walls.
- To avoid the introduction of foreign bodies into the pipes (dust, filings, etc.) always fit the pipes with end caps before handling or work.
- Carefully unwind pipe coils in the opposite direction to the spirals and take care to avoid creating folds or twists.

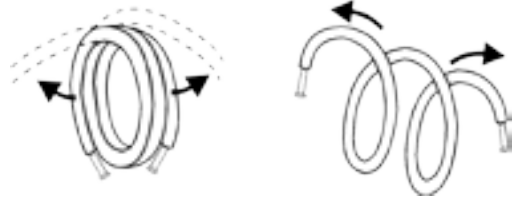

13.1.1. REFRIGERATION PIPE BENDING

The bending radius of the pipes should be equal to or more than 3,5 times de outside diameter of the pipe.

Do not bend the pipes consecutively more than three times and do not make more than 12 bends over the complete length of the link.

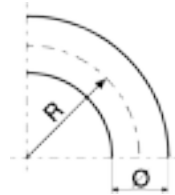

13.1.2. LINK PIPE LENGTHS

Aqu@Scop HT Split appliance is factory-charged with refrigerant for link pipe lengths of up to 20m. By observing the additional charge chart (Refer to the § **REFRIGERANT CONNECTIONS**, appendix VII) this length can be increased to 45m.

Aqu@Scop HT Split appliance can operate with a maximum height difference of 15m between modules.

13.1.3. PIPE BRAZING

Pipes must only be cut with a pipe cutter (no filings) and then de-burred and scoured before brazing.

You are advised to remove all grommets and protect the bodywork before starting any brazing work to avoid damaging the paintwork.

To avoid introducing any scale deposits inside the pipes we recommend that brazing is performed in a dry nitrogen atmosphere by using the 1/4" take-offs on the refrigerant stop cocks. One take-off is used to introduce the nitrogen and the other serves as a vent.

The solder must contain at least 5% silver.



On the Indoor unit, we recommend that you braze the pipe links before making the electrical wiring connections.

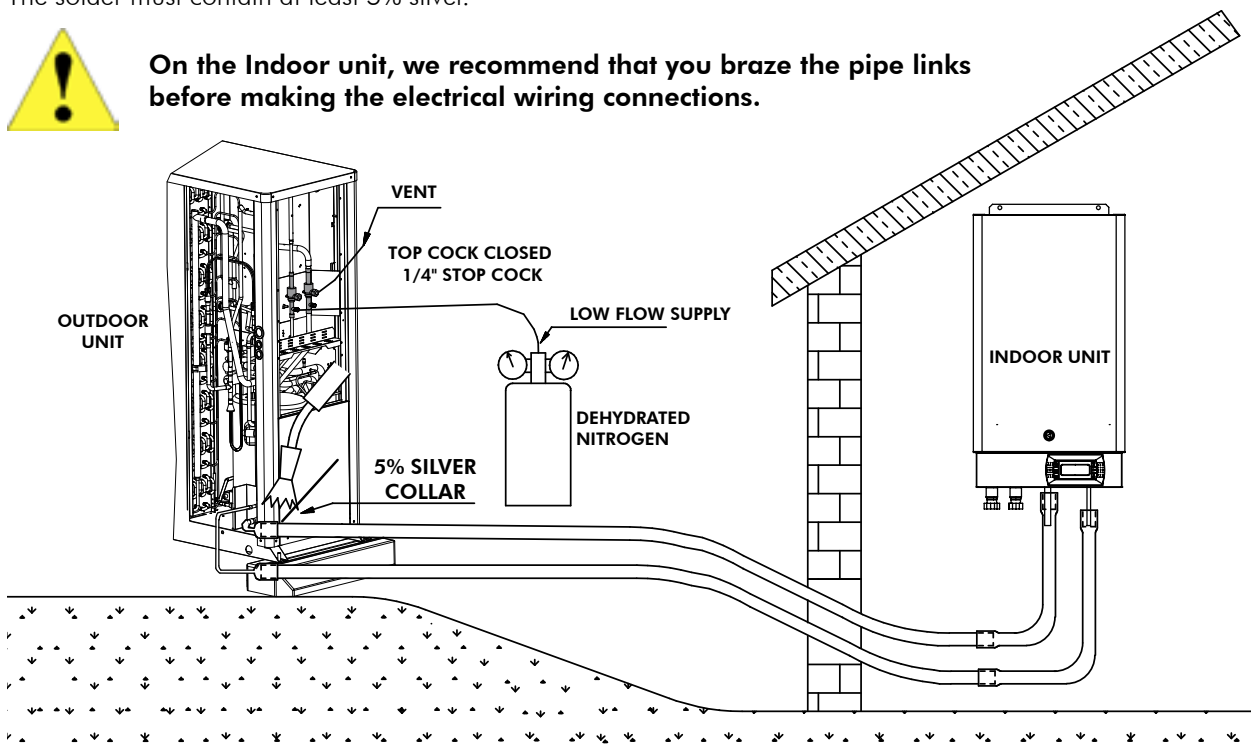

13.2. PIPE INSULATION (NOT SUPPLIED)

In order to avoid heat exchange with the ambient air, we recommend you insulate the pipe links between the Outdoor and Indoor units.

The temperature in the gas pipe can exceed 100°C, while the liquid pipe temperatures are close to water inlet temperatures.

Therefore, it is very important to insulate these pipes with quality lagging compliant with EN ISO 8497 standards (thermal conductivity $\lambda < 0.040$ W/m.K). Furthermore, all pipe links should be protected by lagging of adequate thickness.

In practice, we recommend an insulation thickness of 9mm for the liquid pipe and 13mm for the gas pipe (thermal conductivity $\lambda < 0.040$ W/m.K).

Example on the gas pipe:

- For a temperature difference between the fluid and the ambient air of 100K,
- with 13mm thick insulation (thermal conductivity $\lambda < 0.040$ W/m.K),
- the heat loss is 18.7 W/m.

13.3. VACUUM OF COOLING PIPES AND INDOOR UNIT



Only the outdoor unit is charged with refrigerant fluid. The indoor unit contains a small quantity of a neutral gas. This is the reason it is imperative to vacuum the linking pipes and the indoor unit and **always leave both the stop cocks on the outdoor modules in the closed position.**

You should use a set of pressure gauges or a manifold to carry out this operation.

1. **Keep the Outdoor Unit ball valves closed.**
2. Connect the end hoses to the ¼" take-off situated on the caged-ball valves (one hose on the liquid circuit stop cock and one hose on the gas circuit stop cock). Connect the vacuum pump to the main hose.
3. Open all the valves on the set of pressure gauges. Start the vacuum pump and check that the indicator needle drops to - 0.2 mm Hg. Then leave the pump to run for at least 15 minutes.
4. Before removing the vacuum pump, you must check that the vacuum indicator remains stable for at least five minutes.
5. Isolate the pump by closing the valves on the set of pressure gauges. Then stop the vacuum pump.
6. Open the 2 caged-ball valves.
7. In the case where one of the refrigeration links is 20m higher than the other, you must add an additional refrigerant fluid charge (Refer to the § **REFRIGERANT CONNECTIONS**, appendix VII).
8. To guarantee the tightness of the caged-ball valves, remember to refit the caps once the work is completed.
9. Check tightness of the pipe links. Use an electronic leak detector or a soapy sponge.

14. WIRING DIAGRAM AND LEGEND

14.1. WIRING DIAGRAM

SEE APPENDIX



14.2. LEGEND

N 791

SE 4162	indoor unit 12-6/14-7/18-9	Control	1-Phase	230V +/-10% 50Hz
SE 4163	outdoor unit 12-6	Power	1-Phase	230V +/-10% 50Hz
SE 4164	outdoor unit 12-6	Control	1-Phase	230V +/-10% 50Hz
SE 4165	outdoor unit 14-7	Power	1-Phase	230V +/-10% 50Hz
SE 4166	outdoor unit 14-7	Control	1-Phase	230V +/-10% 50Hz
SE 4167	outdoor unit 12-6/14-7	Power	3-Phases	3N~400V +/-10% 50Hz
SE 4168	outdoor unit 12-6	Control	3-Phases	3N~400V +/-10% 50Hz
SE 4169	outdoor unit 14-7	Control	3-Phases	3N~400V +/-10% 50Hz
SE 4170	outdoor unit 18-9	Power	3-Phases	3N~400V +/-10% 50Hz
SE 4171	outdoor unit 18-9	Control	3-Phases	3N~400V +/-10% 50Hz

14.2.1. POWER SUPPLY

Terminal connections:

OUTDOOR UNIT		INDOOR UNIT
230V +/-10% 50Hz	3N~400V +/-10% 50Hz	Connection to the FFG fuse holder and the earth terminal
➤ L : phase	➤ L1 (L1) : phase	
➤ N : neutral	➤ L2 (L2) : phase	
➤  : ground	➤ L3 (L3) : phase	
	➤ N (N) : neutral	
	➤  : ground	

The appliance's electrical installation and wiring must comply with the country's current standards.

14.2.2. WIRING DIAGRAM KEY DESCRIPTIONS

14.2.2.1. OUTDOOR UNIT

FT1/2 : M1/2 compressors thermo-magnetic relay (three phase models)

FF1/2 : M1/2 compressors protection fuse carrier (single phase models)

KM1/2 : M1/2 compressors power contactor or relay

M1/2 : Compressors

CM1/2 : M1/2 compressors capacitors (single phase models)

AS1/2 : "Soft START" starter

R1/2 : Sump resistance

OF1/2 : Air exchanger fan motor

KOF1 : OF1 fan motor relay

FOF1/2 : OF1/2 motors internal safety

COF1/2 : OF1/2 motors capacitors

CF : OF1/2 fan motor variator

FFC : Control circuit protection fuse carrier

KA1 : Phase sequence and cut-out control module (three phase models)

μPC : Controller

FT1/2 : Thermo-magnetic relays ancillary contacts for M1/2 compressors

HP : Automatic reset high pressure switch

EEV : Electronic pressure relief valve

IHP : Intermediate high pressure switch

DHP : De-icing high pressure switch

RV : 4-way cycle changeover valves

ISV : Injection valve

DRV : De-icing valve

ESV : Oil equalization valve

EP : Pressure transducer (evaporation pressure)

OCT : De-icing temperature probe (evaporator inlet)

CDT : High discharge temperature

CST : Evaporation temperature probe

14.2.2.2. INDOOR UNIT

FFG : Main fuse holder

FFT : T1 transformer protection fuse (24V secondary circuit)

T1 : Ambience terminal 230/24V power supply transformer

WFL : Flow meter (water flow measurement)

WPR : Water pressure sensor

MP : Water pump

KMP : MP water pump relay

EWI : Inlet water temperature probe

LWT : Outlet water temperature probe

14.2.2.3. OPTIONS

DZ WP/2 : Dual zone water pumps

DZ MV : Dual zone mixer valve

SP V : Swimming pool 3-way valve

AEH1 : Backup electric heating (Stage 1)

AEH2 : Backup electric heating (Stage 2)

BOILER : Hot water boiler (ON dry switch)

DHW WP : Domestic Hot Water circulation pump (kit with plate exchanger)

DHW V : Domestic Hot Water 3-way valve

DHW EH : Domestic Hot Water tank electric heating resistance

BR V : Substitute Boiler 3-way valve

DZWT : Dual zone water temperature probe (Under-floor heating outlet)

DHWT : Domestic hot water temperature probe

SPWT : Swimming pool water temperature probe

ON/OFF : Remote ON/OFF switch (Summer/Winter parameter settings)

DAY/NIGHT : Off-peak hours electricity contact (DHW)

EMH : Backup heating switch (electric heater and boiler substitution)

14.2.3. CONTACTOR FUSE RATINGS, NOMINAL CURRENTS SETTINGS (CLASS AC3/AC1)

14.2.3.1. OUTDOOR UNIT

Supply voltages	3N~400V +/-10% 50Hz		
	12-6	14-7	18-9
Only outdoor unit General protection fuse rating (not supplied) aM type (1)	16A	16A	20A
Outdoor unit + indoor unit + accessories General protection fuse rating (not supplied) aM type (1) (2)	16A	20A	20A
Fuse ratings			
FFC aM type	4A	4A	4A
Thermo-magnetic cut-out switch			
FT1 Plage	9 - 14A	9 - 14A	9 - 14A
Réglage	10A	11A	13A
FT2 Plage	4 - 6.3A	4 - 6.3A	4 - 6.3A
Réglage	4.2A	5.1A	6.3A
Contactors			
K1	12A	12A	/
K2	9A	9A	9A

Supply voltages	230V +/-10% 50Hz	
	12-6	14-7
Only outdoor unit General protection fuse rating (not supplied) aM type (1)	32A	32A
Outdoor unit + indoor unit + accessories General protection fuse rating (not supplied) aM type (1) (2)	32A	32A
Fuse ratings		
FF1 aM type	25A	25A
FF2 aM type	12A	16A
FFC aM type	4A	4A
Contactors		
K2	12A	/

(1) These values are provided for information purposes only and must be checked and adjusted in relation to currently applicable standards. They vary depending on the type of installation and the choice of conductors.

(2) Depending on the installation configuration, the power supply to the Indoor unit can either be separate or routed via the Outdoor unit (single master unit circuit protection).

14.2.3.2. INDOOR UNIT

Supply voltages	230V +/-10% 50Hz	
	12-6 / 14-7	18-9
Fuse ratings		
FFG gG type	4A	
FFT T type	1.6A	



This 4A (gG) protection fuse corresponds to the appliance's own consumption, plus the consumption of the various accessories available. Change the fuse rating if the consumption exceeds 4A (installation of additional pumps for example).

15. ELECTRICAL CONNECTIONS

WARNING



Before carrying out any work on the equipment, make sure that the electrical power supply is disconnected and that there is no possibility of the unit being started inadvertently. Non-compliance with the above instructions can lead to injury or death by electrocution.

The electrical installation must be performed by a fully qualified electrician, and in accordance with local electrical standards and the wiring diagram corresponding to the unit model.

Any modification performed without our prior authorisation may result in the unit's warranty being declared null and void.

The power supply cable section must be sufficient to provide the appropriate voltage to the unit's power supply terminals, both at start-up and under full load operating conditions.

The use of under-sized power supply cables can lead to major losses of around 100W to 200W.

The power supply cable shall be selected in accordance with the following criteria:

1. Power supply cable length.
2. Maximum unit starting current draw – the cables shall supply the appropriate voltage to the unit terminals for starting.
3. Power supply cables' installation mode.
4. Cables' capacity to transport the total system current draw.

Short circuit protection shall be provided. This protection shall comprise fuses or circuit breakers with high breaking capacity, mounted on the distribution board.

If the planned installation includes an ambience terminal, the latter must be connected with shielded cable which must not run through the same conduits as the power supply cables, as the possible voltage generated could cause a unit operating fault.

15.1. PHASE SEQUENCE AND CUT-OUT CONTROLLER

VERY IMPORTANT:

3N~400V-50HZ

The outdoor unit is equipped as standard with a phase sequence and cut-out controller located in the electrical box.

THE LED's INDICATE THE FOLLOWING CONDITIONS:

Green LED = 1

Yellow LED = 1

Power ON

The compressor rotation direction is correct.

Green LED = 1

Yellow LED = 0

Phase inversion or phase absent (L1)

The compressor and the fans do not start.

Green LED = 0

Yellow LED = 0

Phase absent (L2 or L3)

The compressor and the fans do not start.

15.2. PROGRESSIVE START-UP

3N~400V-50HZ

The **Aqu@Scop HT Split** 18-9 is equipped with a progressive starter (soft start) for the C1 compressor. The starter is situated in the electrical box of the outdoor unit and marked "AS1".

It is important to check the following settings:

- Start slope 1 s
- Stop slope 0 s
- Minimum starting voltage 60%

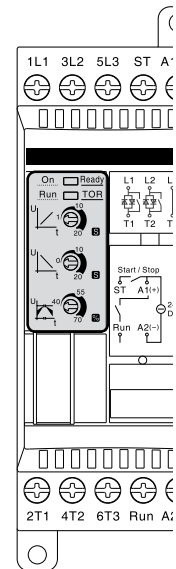
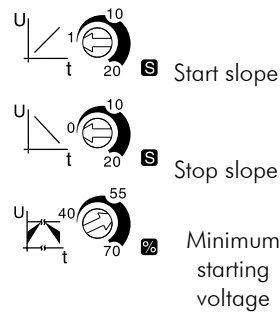

230V +/-10% 50Hz

IMPORTANT :

The compressors are equipped with a soft starter. The starter is situated in the electrical box of the outdoor unit and marked "AS1/2".

THE LED's INDICATE THE FOLLOWING CONDITIONS:

Green diode	Red diode	Meaning	Recommended action	Comments
On	Off	No fault		
Off	Off	No supply voltage present at starter terminals.	Check the power supply to the PAC. Check the condition of the 230V protection fuse. Replace the fuse if it has melted.	
Flashing	Off	Insufficient supply voltage (compressor stopped).	Measure the compressor starter supply voltage at rest. Cut the power supply to the PAC and check whether or not the fault reappears. Refer to the following cause in the event of repeated failure.	
		Defective starter power supply component.	Cut the power supply to the PAC. If the fault persists, replace the starter.	
On	Flashing twice ■ ■	Insufficient compressor starting voltage (<190V).	Check the mains supply voltage at rest. Contact the electricity supplier if < 207V. With the compressor running, check the mains supply voltage and the starter output voltage. In the event of major voltage drop, check the diameter of the PAC power supply cable. As a last resort, contact the electricity supplier.	The alarm resets itself automatically after 5 min. If the fault re-occurs during the next start-up procedure, the compressor seizes and the power supply has to be disconnected to reset it.
On	Flashing 3 times ■ ■ ■	Excessive compressor starting current.	Force the compressor to start several times and check whether it is a one-off or recurring fault.	The alarm resets itself automatically after 5 min. If the fault re-occurs during the next start-up procedure, the compressor seizes and the power supply has to be disconnected to reset it.
			If the fault persists, when the compressor is running, check for normal current draw. In the event of excessively-high current draw, replace the compressor.	
			Starter fault. Replace the starter.	
On	Flashing 4 times ■ ■ ■ ■	Starter internal condenser	Replace the starter.	
On	Flashing 5 times ■ ■ ■ ■ ■	Incomplete or defective compressor starting sequence	Force the compressor to start several times and check whether it is a one-off or recurring fault.	The alarm resets itself automatically after 5 min. If the fault re-occurs during the next start-up procedure, the compressor seizes and the power supply has to be disconnected to reset it.
			In the event of a persistent fault, check the compressor power supply cable.	

15.3. CONNECTIONS

Remove the inspection cover to gain access to the electrical connection box.

Pass the power supply cable through the cable passage provided on the appliance.

Install end fittings suitable for the cable section to ensure a good contact. Make the connections as shown.

15.3.1. MAINS POWER SUPPLY

15.3.1.1. INDOOR UNIT

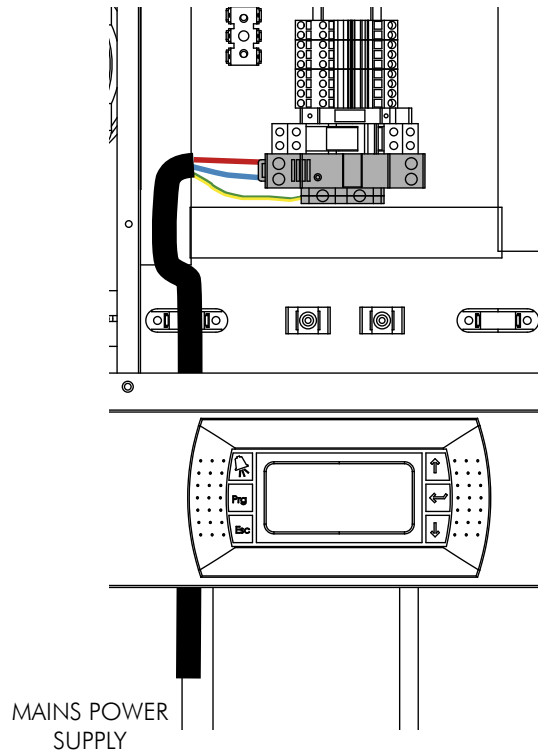
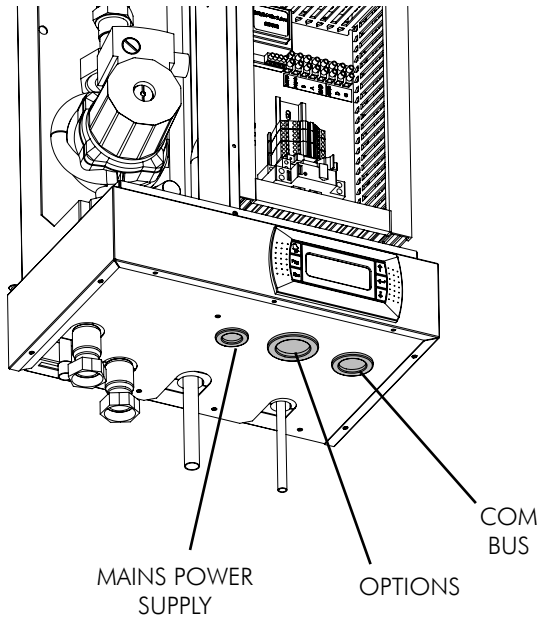

15.3.1.2. OUTDOOR UNIT

A circuit breaker or fuse holder (not supplied) must be installed on the main power supply of the unit in accordance with the circuit diagram; for the ratings, refer to the electrical specifications.

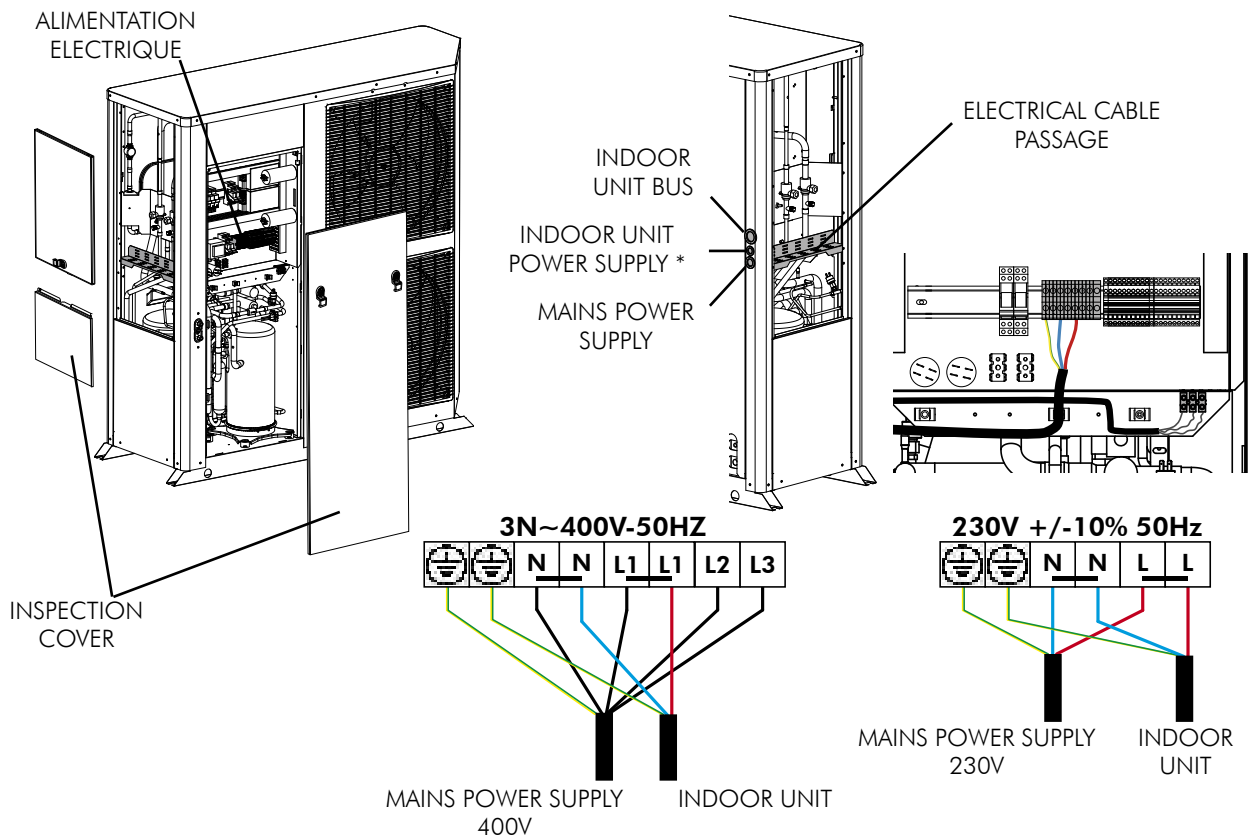

* Depending on the installation configuration, the power supply to the Indoor unit can either be separate or routed via the Outdoor unit (single master unit circuit protection).

15.3.2. AMBIENCE TERMINAL

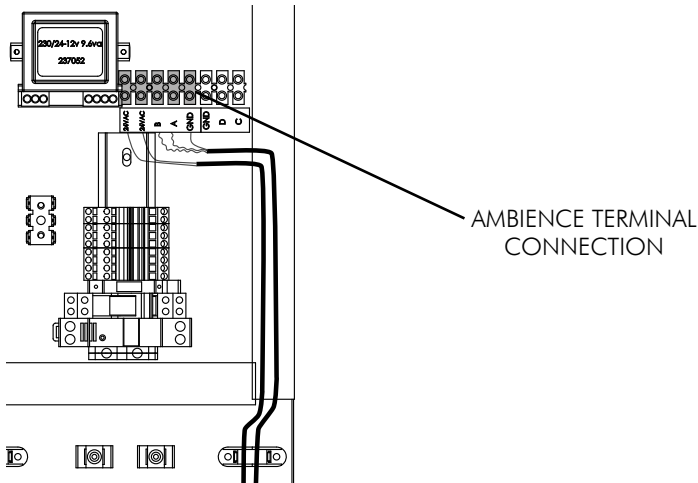

2 separate cables for power supply (24V) and communication (A-B-GND).

Power supply 24V:

Single pair cable: 1 mm²

Communication:

Shielded twisted single pair cable with screen 0.33 mm² to 0.5mm² (AWG 20/22)

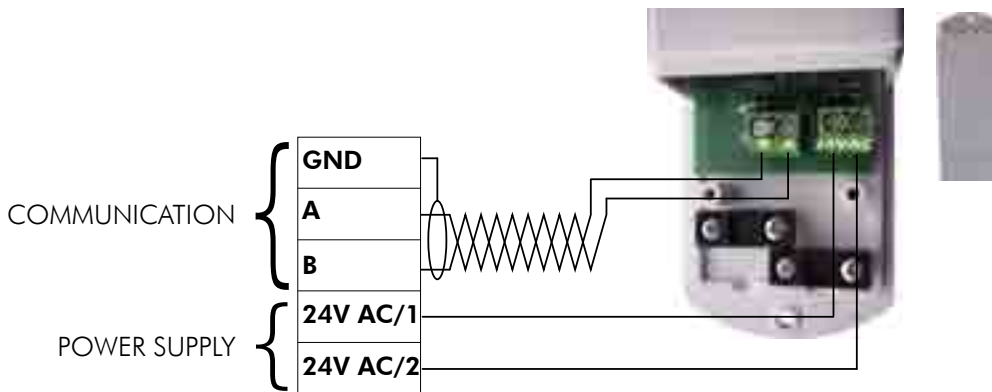
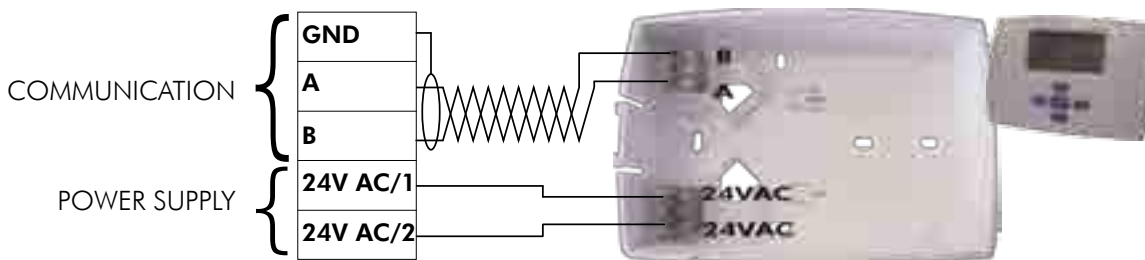

15.3.3. INTERCONNECTION

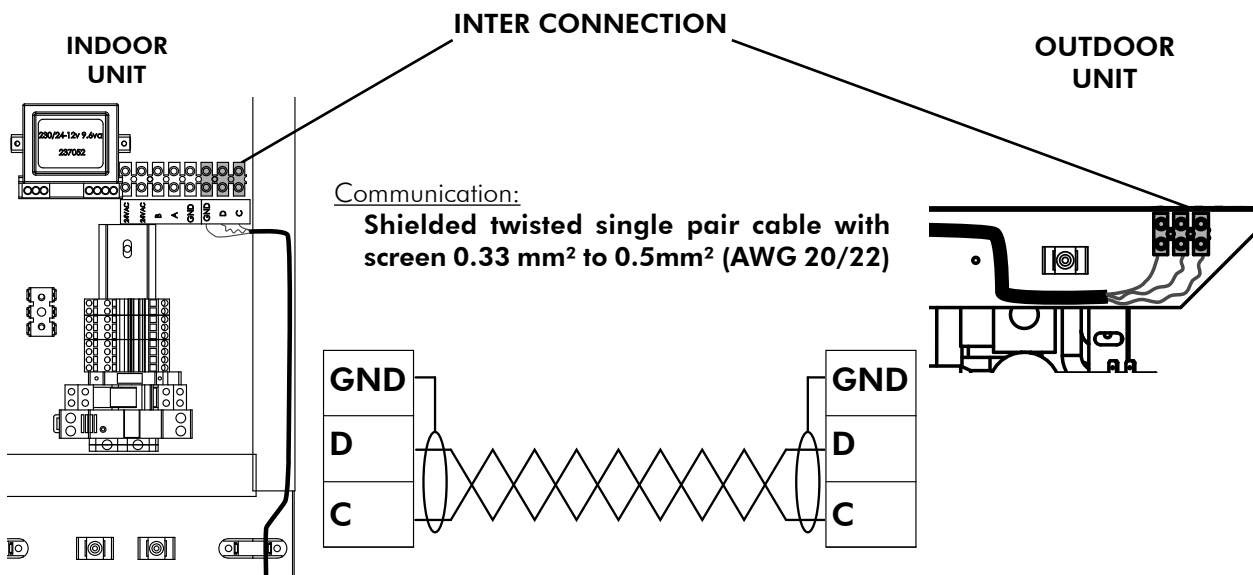

16. DOMESTIC HOT WATER

16.1. CONNECTION TO THE CENTRAL HEATING LOOP

An On-Off 3-way valve directs hot water produced by the **Aqu@Scop HT Split** to either the heating circuit or the domestic hot water tank. Hydraulic connections must be made in accordance with the circuit layout diagrams provided.

Warning: You must ensure that the 3-way valve orifices (marked A, B and AB) are connected correctly to the circuit in order for the valve to operate in accordance with the electrical diagram provided.

16.1.1. 3-WAY HEATING / DOMESTIC HOT WATER VALVE

Fit the valve in accordance with the flow direction marks etched on the valve.

THE CONNECTIONS MUST CORRESPOND EXACTLY WITH THE FLOW DIRECTIONS INDICATED ON THE LAYOUT DIAGRAM FOR THE TYPE OF INSTALLATION.

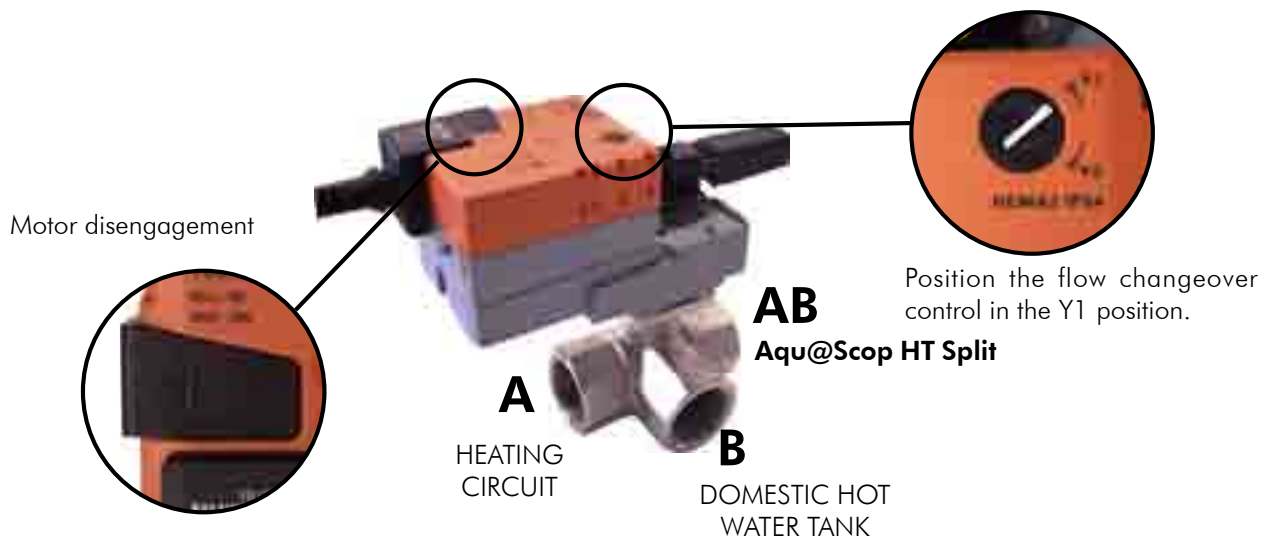

16.1.1.1. ELECTRICAL CONNECTIONS

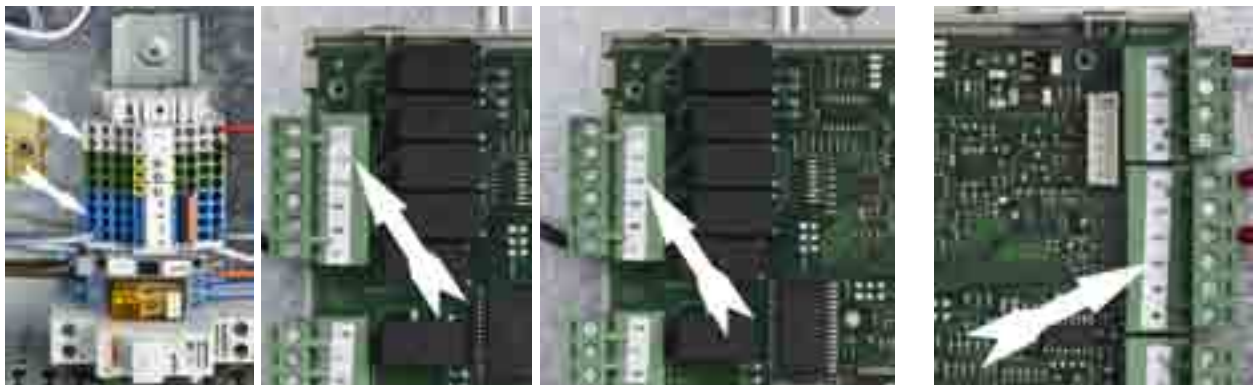
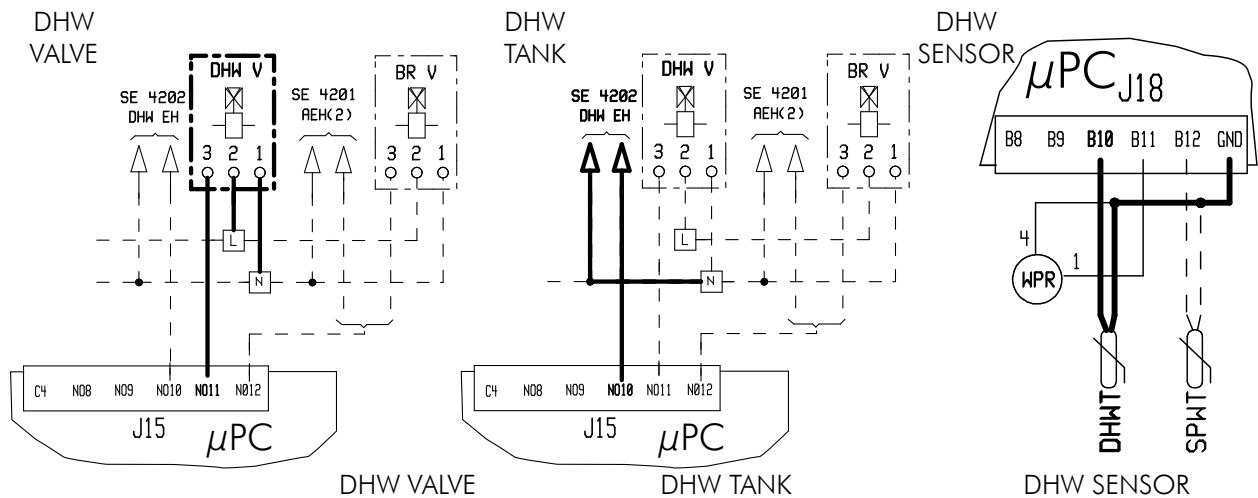

16.2. DOMESTIC HOT WATER PRODUCTION MODES

The **Aqu@Scop HT Split** controller manages domestic hot water production in accordance with the following operating modes:

- **PERMANENT COMFORT MODE**
Domestic hot water production has priority over heating except when the ambience temperature / set temperature difference is greater than 2° C (Maximum one hour).
Example: Set temperature = 20°C, Ambience < 18°C
- **ECONOMY MODE**
Domestic hot water is produced during off-peak hours (dry contact) or in accordance with times programmed in the controller.
Option: Possibility to restart domestic hot water production outside off-peak hours if the water temperature has reached a programmable minimum temperature.
- **IMMEDIATE DOMESTIC HOT WATER PRODUCTION**
The **Aqu@Scop HT Split** 's regulator enables domestic hot water production to be forced as required. At the end of the cycle, the system returns to its usual operating mode.

The Legionnaires' Disease protection treatment managed by the **Aqu@Scop HT Split** 's controller is fully programmable (frequency, temperature threshold, treatment length).

The PERMANENT COMFORT and ECONOMY modes place priority on thermodynamic heating. In the event of excessive demand for Domestic Hot Water Temperature that does not permit the compressor(s) to operate, the backup electric heating function is activated. In order to achieve energy savings, it is important to use the lowest possible set temperature points.

We recommend:



Eco set temperature < Comfort set temperature < 53°C

16.3. DOMESTIC HOT WATER HEATING FUNCTION ACTIVATION

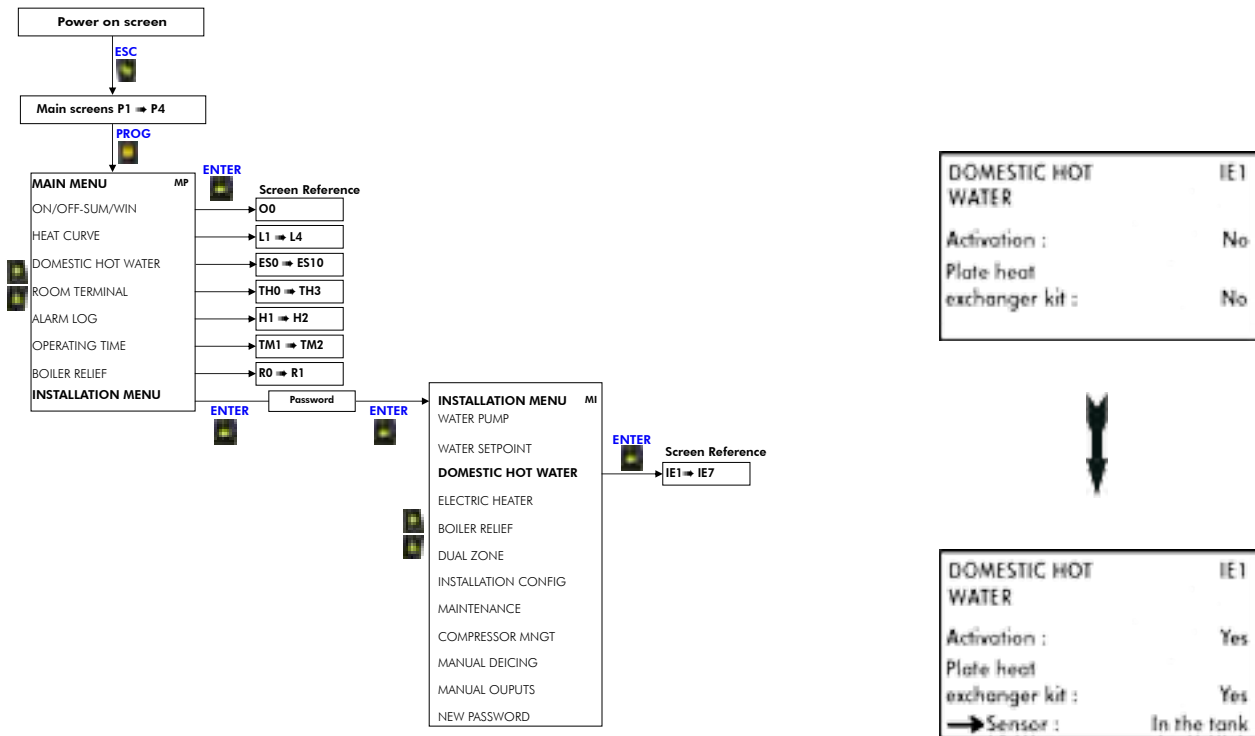

17. IN-LINE ELECTRIC HEATER

17.1. ELECTRICAL CONNECTIONS

SEE APPENDIX

17.2. OPERATING MODE

Operating parameters for these modes can be set via the display on the **Aqu@Scop HT Split**.

17.2.1. BOOST MODE

The backup electric heating offers additional capacity when the demand for heating is higher than the capacity of the **Aqu@Scop HT Split**. The aim is to maintain occupant comfort, while favouring thermodynamic operation for optimised performance.

The resistances are only activated below a certain outdoor temperature (values can be set for Stage 1, AEH1 and Stage 1+2, AEH1+AEH2) and only if the **Aqu@Scop HT Split** regulation system detects a lack of capacity in compressor only mode (check on water temperature and ambient temperature).

Activation of the EMH Back-up switch on the heater switches the **Aqu@Scop HT Split** into Back-up mode.

17.2.2. BACK-UP MODE

As opposed to Booster mode, this mode operates only when the user activates the EMH Back-up switch (this supposes an alarm on the **Aqu@Scop HT Split**). Outdoor temperature conditions are overridden and priority is no longer given to the thermodynamic mode but to the heating resistances that are nevertheless still controlled by the **Aqu@Scop HT Split**.

17.3. ELECTRIC HEATER FUNCTION ACTIVATION

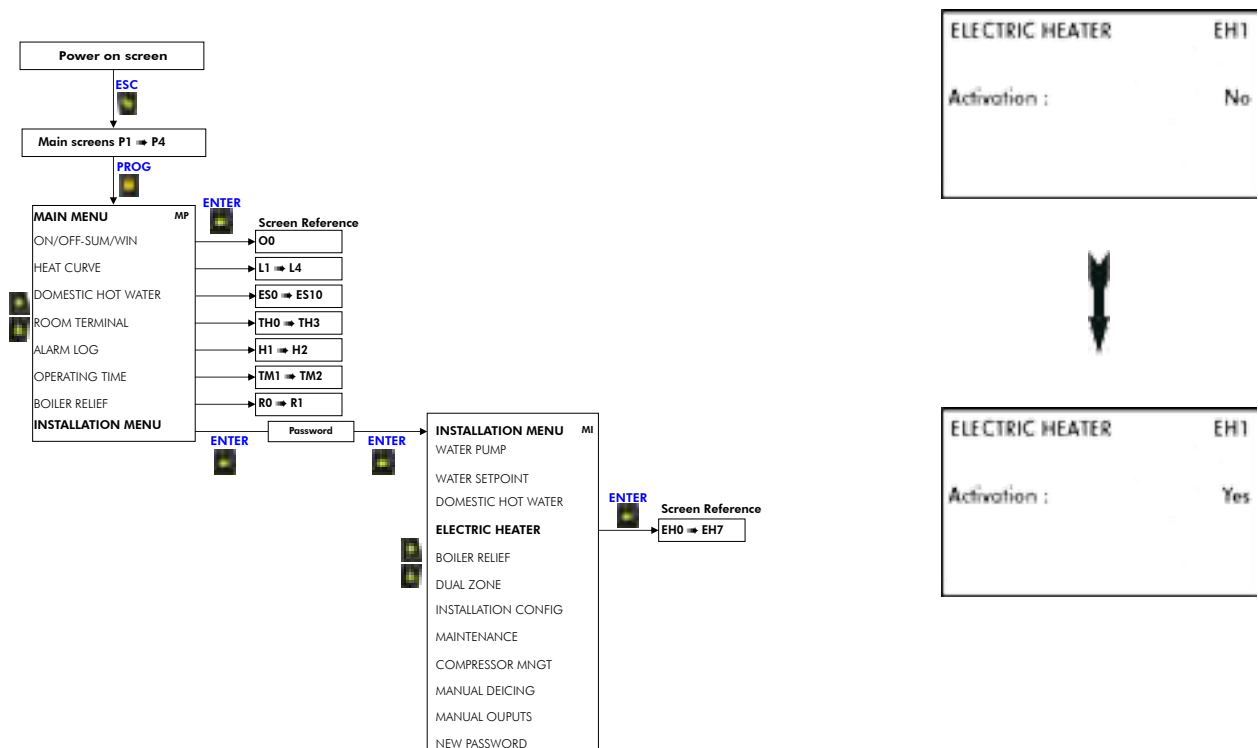

18. BOILER RELIEF

18.1. ELECTRICAL CONNECTIONS

The boiler relief function uses the digital outputs of the in-line electric heater function to control the hot water boiler ON/OFF switch (Boiler dry contact switch) as well as a 3-way valve output (230V BRV). A switch should be wired to the ICS input to ensure operation in Back-up mode.

18.2. OPERATING MODES

Operating parameters for these modes can be set via the display on the **Aqu@Scop HT Split**.

18.2.1. BOOST MODE

Hot water boiler operation is only authorised below a certain set outdoor temperature value and the appliance can also be placed in forced shutdown mode below a different outdoor temperature value. Just as the electric heater, the **Aqu@Scop HT Split** continuously checks the water temperature and the ambient temperature to optimise compressor operation and to only start the hot water boiler when absolutely necessary.

The **Aqu@Scop HT Split** can also be set to manage a heat curve on the hot water boiler higher than the temperature set for the appliance (65° C maximum).

18.2.2. BACK-UP MODE

Activation of the EMH switch (to be wired by the installer) or the Back-up parameter, via the "Boiler Relief" tab on the main menu of the **Aqu@Scop HT Split** display, switches the system into Back-up mode and both outdoor temperature and ambient temperature conditions are overridden.



We strongly recommend the installation of the ambience terminal for effective operation of the Boiler Relief function. In the absence of an ambience terminal the Aqu@Scop HT Split will be unable to optimise hot water boiler operation and this will lead to unnecessary energy consumption.

18.3. BOILER RELIEF FUNCTION ACTIVATION

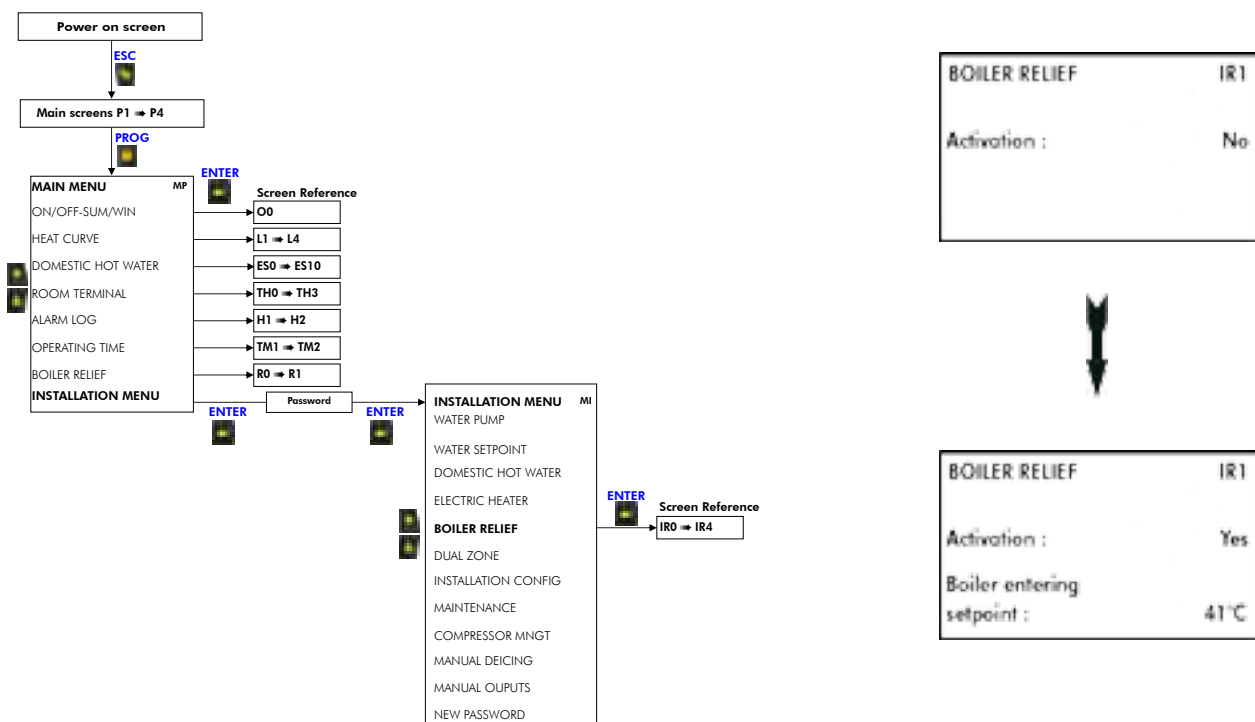

19. DUAL ZONE

19.1. ELECTRICAL CONNECTIONS

SEE APPENDIX

19.2. ACTIVATING THE DUAL ZONE FUNCTION

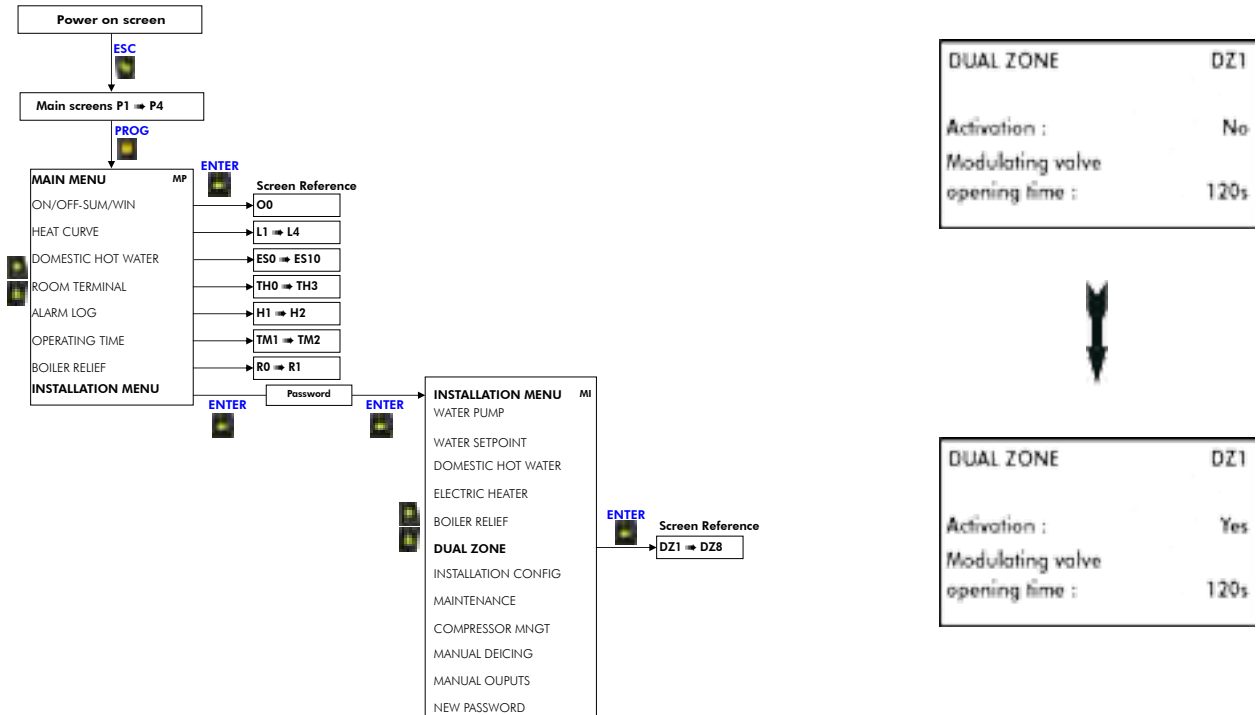

You MUST install one room terminal per zone.

You must specify the type of emitter for each zone. Zone 1 corresponds to the low temperature zone. Setting the **Aqu@Scop HT Split** controls the water output temperature using the **DZMV** modulating valve and the **DZWT** temperature sensor.

19.3. AMBIENCE TERMINAL

The double zone function requires the use of one ambience terminal per zone. You must specify one address per ambience terminal.



- Zone 1 : Address 1
- Zone 2 : Address 2



CHANGING THE AMBIENCE TERMINAL ADDRESS FOR ZONE 2.

See the communicating ambience terminal's installation manual (IOM WATTS 01-N-2ALL).

ZONE CONFIG.	DZ3
ROOM TERMINAL	
Zone1 :	Yes
Zone2 :	Yes

HEAT APPLICATION	DZ4
Zone1 Floor heating	Zone2 Radiators
	

20. COMMISSIONING

20.1. PRE-START CHECK LIST

Before commissioning the system, you must carry out a certain number of installation checks to ensure that the appliance will operate in the best possible conditions. The following list of checks is not exhaustive and only serves as a minimum reference guide.

20.1.1. VISUAL CHECK

1. Check free clearances around the unit, including the exchanger air intake and outlet, and access for maintenance work.
2. Comply with the free clearance dimensions around the domestic hot water tank.
3. Check unit assembly in accordance with specifications.
4. Check presence and tightness of all screws and bolts.
5. Check the position of the rubber anti-vibration pads or the vibration-absorbing supports.
6. Check that the unit is level and that condensates drain freely away from the unit.
7. Check that there is no possibility of blown air being recycled through the fans due to wind exposure.
8. In arduous climates (sub-zero temperature, snow, high humidity), check that the appliance is raised 10 cm off ground.
9. Check that the ambience terminal is located correctly (frequently occupied area, 1.5 m above ground level, etc.).
10. For refrigerant leaks in connections and components.

20.1.2. ELECTRICAL CHECK

1. Electrical installation has been carried out according to unit wiring diagram and the Supply Authority Regulations.
2. Size fuses or circuit breaker has been installed at the main power supply.
3. Supply voltages as specified on unit wiring diagram.
4. Check the tightness of wire to component connections.
5. the cables and wires are clear of or protected from pipework and sharp edges.
6. Check the electrical grounding of the appliance.

20.1.3. HYDRAULIC CHECK

1. Check that the external water circuit components (pumps, user equipment, filters, expansion tank and reservoir if supplied) have been correctly installed in accordance with the manufacturer's recommendations and that the water inlet and outlet connections are correct.
2. Check the presence, direction and position of the **water filter** upstream of the appliance. Rinse the filter after the first 2 hours of operation.
3. Check that the water quality complies with stated standards.
4. Check that the hydraulic circuit is filled correctly and that the fluid flows freely without any signs of leaks or air bubbles.
5. Adjust the water flow in order to comply with the specifications. (Refer to the § **WATER FLOW REGULATION**, page 21)
6. Check the presence and position of the stop cocks to isolate the appliance for maintenance.
7. Check the presence of the air bleed valve.
8. Check protection against freezing (heat isolation, antifreeze percentage if required...).
9. Check that the bleed valve in the appliance has been opened.

21. STARTING THE APPLIANCE

After checking all the electrical connections and making any rectifications as required, proceed with starting up the installation.

21.1. USER INTERFACE

The terminal is a 6-button, 8-line x 22-character LCD model, which can display text in various sizes and icons.



21.1.1. KEYPAD

ALARM  : When you press the Alarm key (the red bell is apparent if an alarm is active), the first active alarm is displayed on the screen and the screen buzzer is switched off (if active). Use the UP/DOWN keys to view all the active alarms. Press the Alarm key a second time to cancel all alarms that can be cancelled in this manner. Alarms that remain active are still displayed. If no alarm is active, pressing the key returns the system to the "NO ALARM ACTIVE" screen.

ESC  : Moves to previous level in the menu arborescence. Press this to change an analogue or integer variable, such as 34.5 for example (as opposed to a digital variable such as Yes/No), to cancel the current change and return to the previous menu. This function is very important if a parameter is changed by mistake.

PROG  : From any screen, this key returns to the main menu. Just as the ESCAPE key, this key cancels the current change.



UP/DOWN   : These keys have several functions:

In a menu, they enable you to scroll through the list of available selections. When the cursor is placed in the top left hand corner of the screen it is possible to scroll through the screens available in this arborescence. Finally, these keys enable you to change the value of a parameter when the cursor is placed on the parameter in question.

ENTER  : On those screens where it is possible to change one or several parameters, the first press on the key moves the cursor to the first parameter on the screen. A second press validates the current parameter and the cursor scrolls to the following parameter until it returns to the upper left hand corner.

21.1.2. BACKLIGHTING

All the screen keys are backlit.

The ALARM key diode lights up when at least one alarm is active. The  key is lit when you are in the main menu or in one of its sub-menus. The , ,  and  keys light up along with the display backlighting. If no key is pressed during a 5 minute period, the display automatically reverts to the first main screen (P1) and all backlighting is switched off.

21.1.3. MENUS

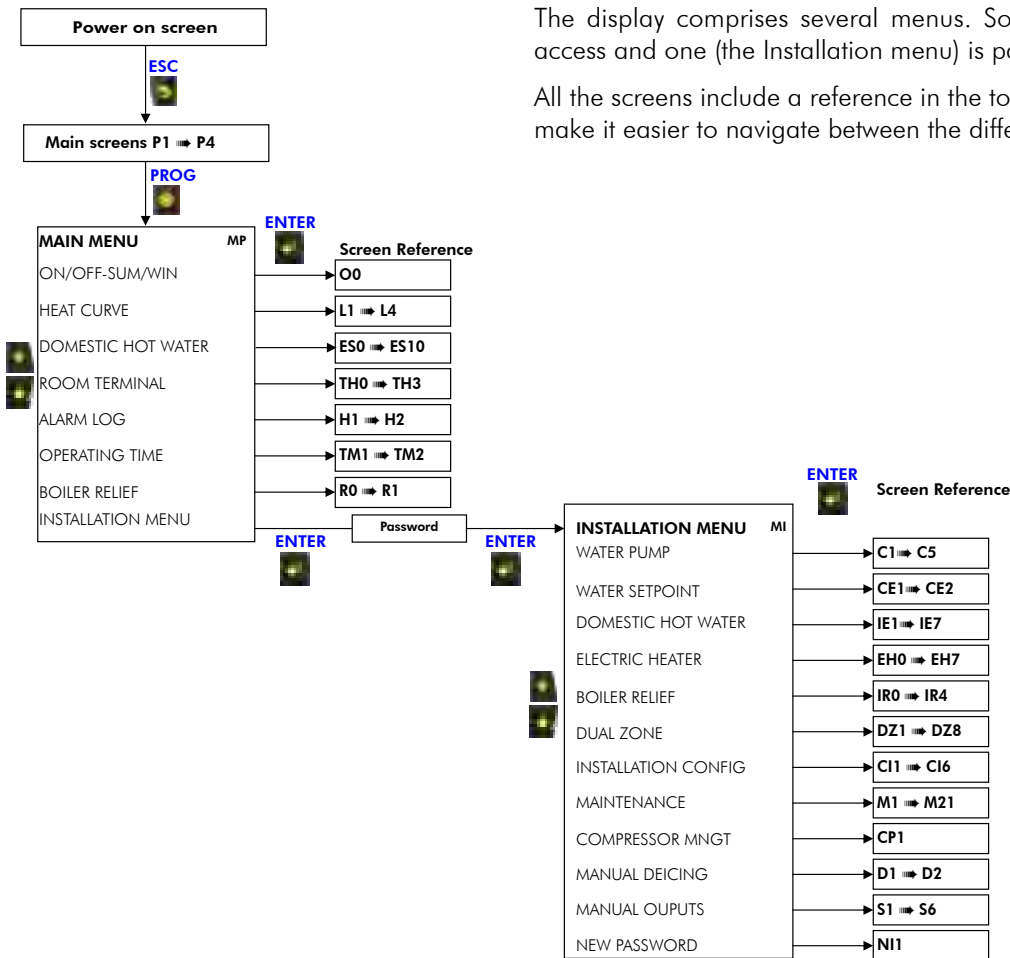

The display comprises several menus. Some have unrestricted access and one (the Installation menu) is password protected.

All the screens include a reference in the top right hand corner to make it easier to navigate between the different menus.

21.1.4. ICONS

P1		Outlet water set temperature, calculated from the heat curve parameters, the outdoor temperature, the ambience set temperature and the variance between the set and the ambience temperature.
		Compressor 1 (large) in operation - Flashing => Compressor in time delay
		Compressor 2 (small) in operation- Flashing => Compressor in time delay
		Fan 1 (upper) in operation
		Fan 2 (lower) in operation
		Outlet water temperature
		Inlet (return) water temperature
		Aqu@Scop HT Split in Summer mode
		Flashing: Countdown for de-icing Fixed on: De-icing in progress
P3		Circulation pump in operation
		Instantaneous outdoor temperature
		Reference outdoor temperature used by the Aqu@Scop HT Split (upper fan special management)
		Evaporator inlet temperature (used for calculating the length of the de-icing time period).
		Domestic hot water temperature (when the option is installed)
		Aqu@Scop HT Split in domestic hot water production mode (flashing)
		Electric heater Stage 1 in operation (flashing)
		Electric heater Stage 2 in operation (flashing)
	Hot water boiler in operation (flashing)	

21.2. SIMPLIFIED START-UP PROCEDURE

21.2.1. MAIN SCREENS

On the **Aqu@Scop HT Split** display, after having checked the coherence of the temperature probes on the main screens **P1**, **P2** and **P3**, as well as effective communication with the ambience terminal, it is advisable to set the heat curve parameters before starting the **Aqu@Scop HT Split**. The main screen **P1** is accessible by pressing the key  several times. The main screen **P1** also appears after 5 minutes of display inactivity.

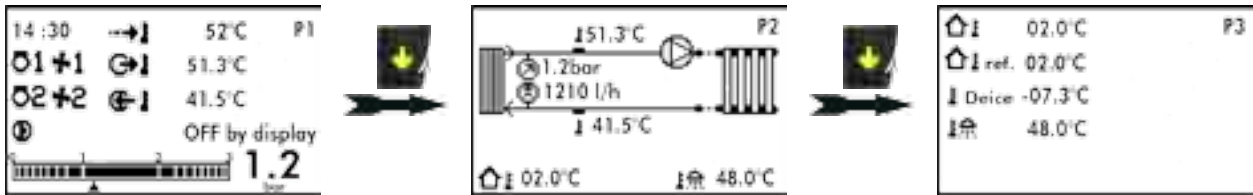

21.2.2. INSTALLATION CONFIGURATION

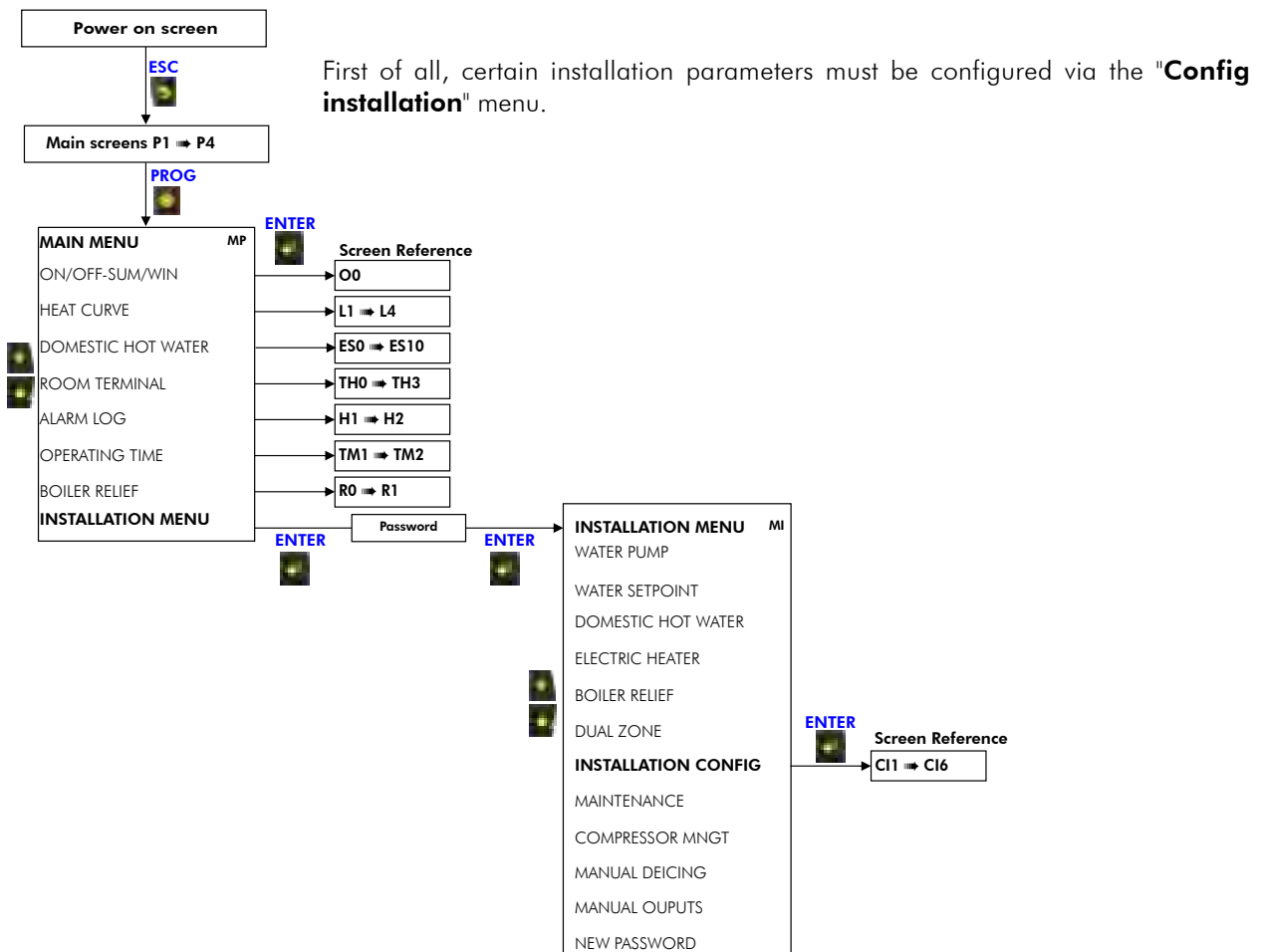

C11 Configuration of the type of heating emitter: radiators or under-floor heating. Changing this parameter automatically leads to changes in the water law parameters. It is very important to configure this parameter before making any alterations whatsoever to the water law parameters and before starting the **Aqu@Scop HT Split** for the first time.

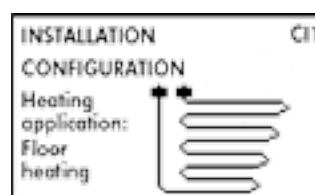
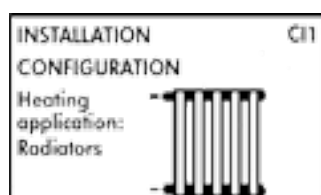

C12 Outdoor temperature probe. This probe should not be installed remotely.



C13 Ambience terminal Activation/deactivation (Default setting: activated). The temperature differential parameters in relation to the set ambient temperature control the starting and stopping of the **Aqu@Scop HT Split** in terms of ambient temperature (even though the water law is also managed by ambient temperature conditions). As a default setting, the PAC will stop at the set ambient temperature + 1°C and restart at the set ambient temperature + 0.5°C (this enables the installation to anticipate any drop in ambient temperature and avoid excessive temperature fluctuations).

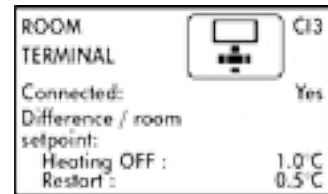
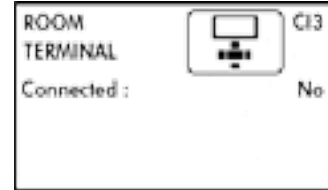

C14 Configuration of the remote all or nothing ON/OFF input. Refer to the Indoor unit wiring diagram.

In ON/OFF configuration, this input enables the **Aqu@Scop HT Split** to be stopped completely. When the boiler substitution function is activated, switching to OFF automatically activates the boiler. It is possible to configure this input as Normally Open or Closed (Default setting: NO).

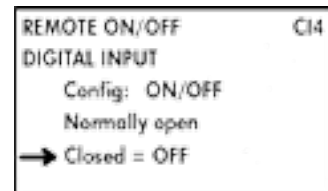

In SUMMER/WINTER configuration, this input stops the Heating function while maintaining the DHW function active (equivalent to the ambience terminal switching to OFF). NO (Normally Open) or NC (Normally Closed) configuration is also possible.

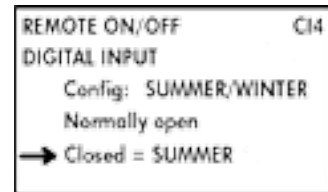



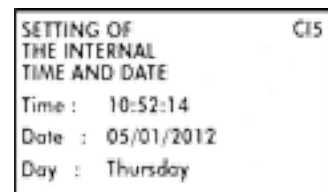

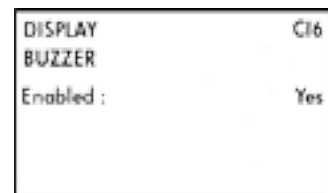

C15 Refer to the § **INDOOR UNIT TIME AND DATE VERIFICATION**, page 42.



C16 Display buzzer authorisation in the event of an alarm (Default setting: authorised).



21.2.3. HEAT CURVE PARAMETERS

On the main menu (key ) , use the  /  arrows to highlight the "HEAT CURVE" menu. Validate this selection with the  key. This moves the display to the **L1** screen. Use the  and  /  keys to set the following parameters:

Screen L1

HEAT CURVE	L1
Altitude :	0.0 km
Base outdoor temperature :	-07°C
Correction Coef. :	0.8

Altitude: Installation site altitude, in km (e.g. 0.5km equals 500m. Default setting: 0).

Base outd. T.: Typical outdoor temperature for the installation region (Default setting: -7°C).

Corr. Coef.: Correction Coefficient for the base of the slope. This is a simple way of changing the water set temperature (Default setting: 0.8).

RADIATOR HEAT CURVE PARAMETERS

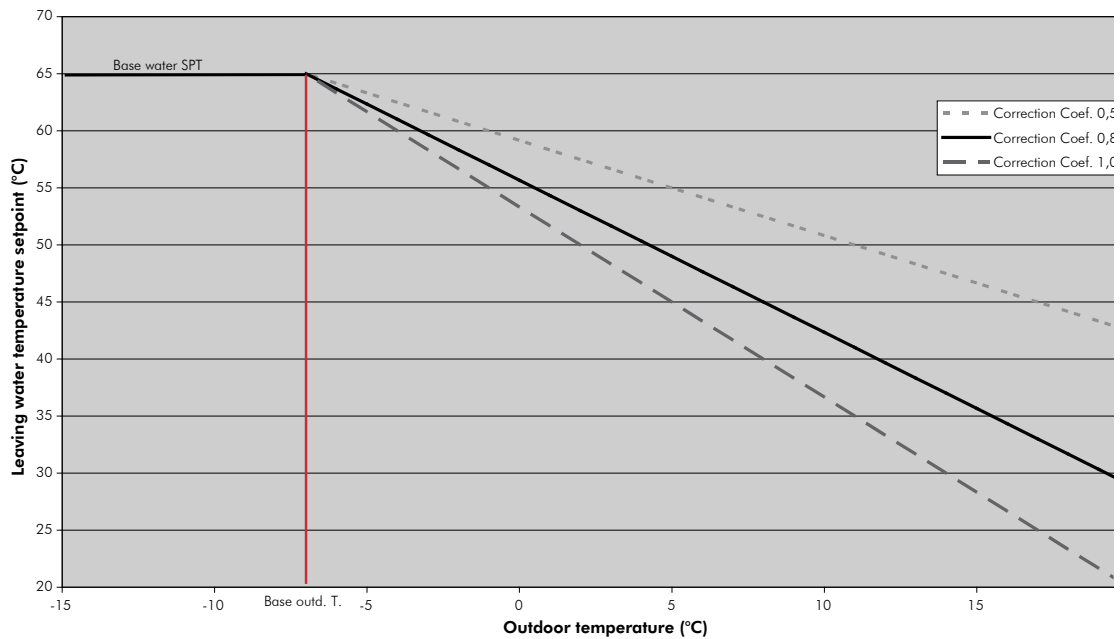

Screen L2

HEAT CURVE	L2
Heat loss at base outdoor temperature :	12.9kW
Water outlet at -7°C outdoor :	65°C

Losses at base Outdoor Temp : Estimated heat loss for the dwelling for an ambient temperature of 20°C and a base outdoor temperature (e.g. -7°C). This parameter is used to calculate the outdoor temperature that triggers the change from small compressor mode to two-stage compressor mode. This value is capped at the maximum capacity of the **Aqu@Scop HT Split** model in question for this same outdoor temperature (Default value = Maximum value).

Water outlet temperature at -07°C Outdoor temperature : Outlet water temperature required at the base outdoor temperature (-7°C for example) to have an ambient temperature of 20°C (Default setting: 65°C).

Screen L3

Outdoor temperature balance point	L3
DEFAULT	
$C2(\text{small}) / C1 + C2$	
06.0°C	

Information screen for the outdoor temperature calculated automatically by the **Aqu@Scop HT Split** . With the preceding default parameters, the value of 5.4° C means that below an outdoor temperature of 5.4° C the **Aqu@Scop HT Split** will start the large compressor or the two-stage compressor. Above 5.4° C the **Aqu@Scop HT Split** will start the small compressor.

Screen L4

Outdoor temperature balance point	L4
AUTOMATIC	
$C2(\text{small}) / C1 + C2$	
06.0°C	
Reset:	No

The value of the outdoor balance temperature displayed on **L4** is the one updated by the **Aqu@Scop HT Split** after running for some time, in the event that the **Aqu@Scop HT Split** detects a lack of capacity with the small compressor.

Zero reset: This is required in the event of changes to the heat curve parameters in order for the **Aqu@Scop HT Split** to register these changes. The parameter on screen **L3** is then recopied into screen **L4**.

21.2.4. VERIFICATION OF COMMUNICATION WITH THE COMMUNICATING AMBIENCE TERMINAL

Screen TH1

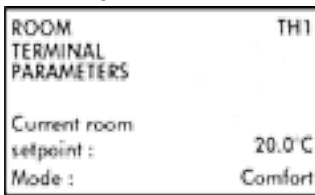

By default, the ambience terminal is declared in the regulator. This means that an alarm will be visible on the screen of the **Aqu@Scop HT Split** a few seconds after the power supply is switched on, if the terminal is not connected. Proper terminal operation can be checked on screens **TH1** to **TH3**.

Screen TH0



All the terminal parameters are accessible via the "**Ambience Terminal**" menu in the main menu (key).

Screens: TH0 to TH3.

The screen **TH0** appears when the terminal is deactivated (installation menu) or disconnected. This screen provides access to a set temperature to facilitate the inputting of water law offset values.

21.2.5. COMPRESSOR SUMP HEATER FUNCTION ACTIVATION

After the first power ON (compressors OFF), **and for any outdoor air temperature**, manually switch ON the compressor sump heaters.

Before starting the compressors, the sump heaters must be powered On for at least 2 hours in order to evaporate any liquid refrigerant that could be in the compressors to ensure their lubrication at the first start-up.

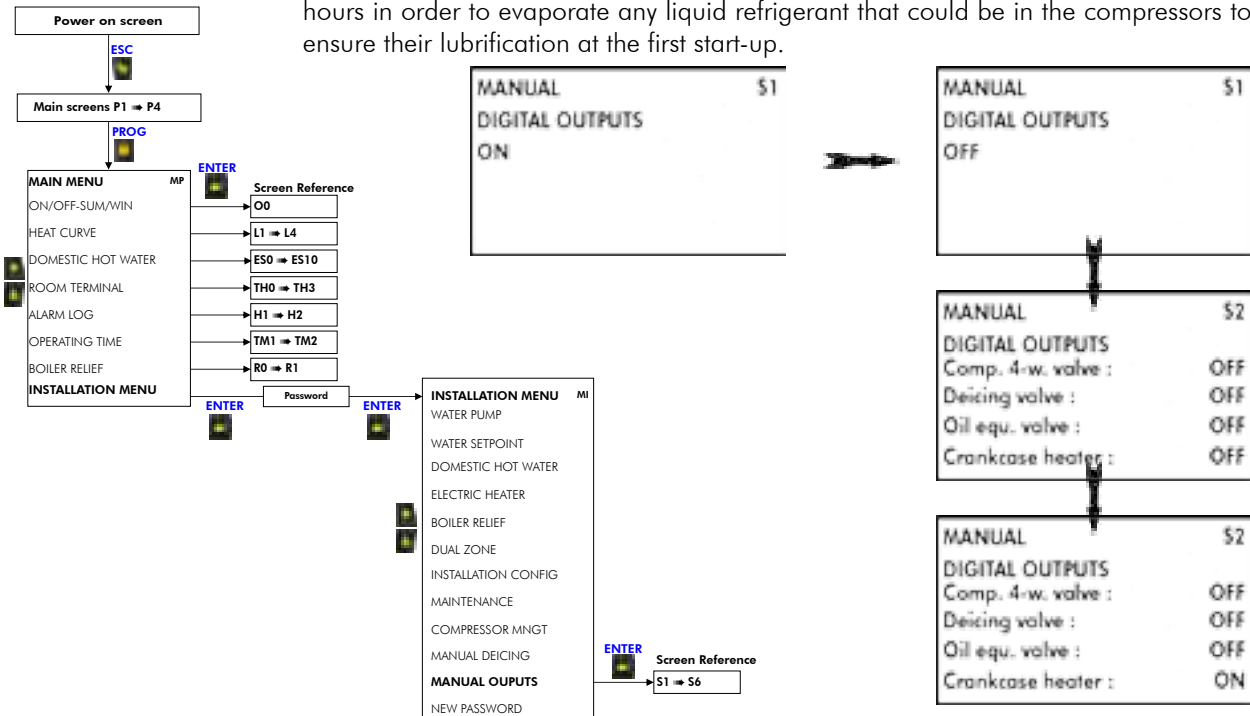

21.2.6. INDOOR UNIT TIME AND DATE VERIFICATION

The time and the date are used to manage the:

- Alarm log.
- The DHW Legionnaires Disease protection function.

When a communicating ambience terminal is connected to the **Aqu@Scop HT Split**, the time is automatically updated in the Indoor unit's regulator. The date is managed solely by the regulator. At commissioning, check:

- The date, screen **P4**. Update as required in the "**Config installation**" CI5 menu.
- The time (screen **P4**) if no ambient terminal is connected. Update as required in the "**Config installation**" CI5 menu.





21.2.7. AQU@SCOP HT SPLIT ON/OFF SETTINGS

In order to start, the **Aqu@Scop HT Split** must always be **ON** at the level of the appliance's display. In addition, the ambience terminal must be in demand mode (when it is connected). To force the terminal to enter demand mode, change it to Comfort mode ☀ with an ambience temperature set at 30° C.

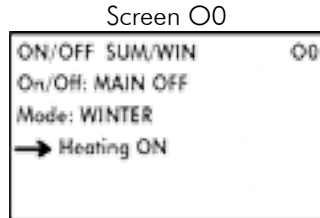

The appliance **OFF** function will always have priority and therefore you will never be able to start the **Aqu@Scop HT Split** in this mode.



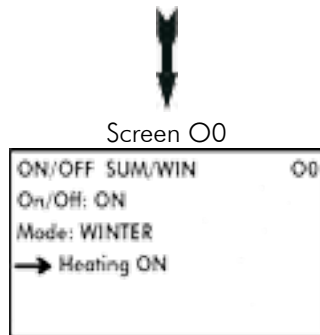



From the main menu, use the  /  arrows to highlight the "**ON/OFF-SUMMER/WINTER**" menu. Validate this selection by pressing the  key. The display moves to the **00** screen.



Press the  key twice to move the cursor to the **GENERAL OFF** parameter.

Use the  /  arrows to change this parameter to **ON**.

Press  to validate and then on the key  ..

If the ambience terminal is in demand mode, and if no alarm is active and the water temperature condition permits (inlet water  at least 7° C below set temperature ), the **Aqu@Scop HT Split** will start operating.

Normal **Aqu@Scop HT Split** operation is guaranteed with an appliance inlet (system return) water temperature above 20° C.

21.3. OPERATING CHECK LIST

21.3.1. GENERAL

Check for any unusual noises or vibration in the running components, particularly the fan drive system.

21.3.2. PHASE ROTATION PROTECTION

If the phase of the power supply are not correct, the phase rotation protection device will prevent the machine from starting.

21.3.3. ELECTRICAL

21.3.3.1. OPERATING VOLTAGE:

Recheck voltage at unit supply terminals.

21.3.3.2. CONTROL

1. Verify all sensor inputs, using the controller display.

21.3.4. FAN & DRIVE

1. Check that the fans rotate freely, in a balanced manner without any rubbing.

21.3.5. COMPRESSOR AND REFRIGERATION SYSTEM

1. Checking operation: Start the **Aqu@Scop HT Split** . Check for any abnormal noises or vibrations.
2. After a few minutes operation, the evaporator outlet superheating should be:

- ✓ 3K (± 1 K) with C2 compressor operating on its own,
- ✓ 5K (± 1 K) with C1 + C2 compressors or C1 operating on its own. (*)

* These checks can be performed at the time of commissioning with the help of qualified technical personnel.

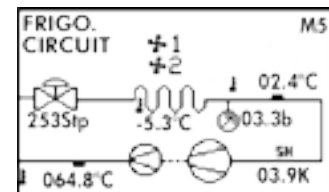

21.3.6. FINAL CHECK

1. All panels and fan guards are in place and secured.
2. Unit clean and free of remainder installation material.

22. FINAL TASKS

Place the plugs back on the valves and check that they are properly tightened.

If needed, fix the cables and the pipes on the wall with clamping collars.

Operate the **Aqu@Scop HT Split** in the presence of the user and explain all functions.

Take care

It is not the manufacturer's policy to make recommendations in terms of water treatment (please contact a specialised water treatment company).

However, given the critical nature of this subject, particular care should be taken to ensure that, if treatment is required, it works effectively.

Using untreated or unsuitable water leads to excessive clogging inside the plate heat exchangers (earth and mud deposits, corrosion, etc.) with major consequences on the thermal efficiency of the unit and irreversible damage to the equipment.

The manufacturer and its representative decline all responsibility in the event of untreated or incorrectly treated water being used.

23. IN CASE OF WARRANTY - MATERIAL RETURN PROCEDURE

Material must not be returned without permission of our After Sales Department.

To return the material, contact your nearest sales office and ask for a "return form". The return form shall be sent with the returned material and shall contain all necessary information concerning the problem encountered.

The return of the part is not an order for replacement. Therefore, a purchase order must be entered through your nearest distributor or regional sales office. The order should include part name, part number, model number and serial number of the unit involved.

Following our personal inspection of the returned part, and if it is determined that the failure is due to faulty material or workmanship, and in warranty, credit will be issued on customer's purchase order. All parts shall be returned to our factory, transportation charges prepaid.

24. ORDERING SERVICE AND SPARE PARTS ORDER

The part number, the order confirmation and the unit serial number indicated on the name plate must be provided whenever service works or spare parts are ordered.

For any spare part order, indicate the date of unit installation and date of failure. Use the part number provided by our service spare parts, if it not available, provide full description of the part required.

25. MAINTENANCE

The user is responsible for ensuring that the unit is in perfect working order and that the technical installation and **minimum annual maintenance** operations have been performed by a qualified technician in accordance with the procedures described in the present manual.



Some alarms can only be cancelled by switching the **Aqu@Scop HT Split** to **OFF**.

Generally, an alarm means that there is an anomaly present on the appliance. We **strongly** recommend that you refrain from repeatedly resetting an alarm without rectifying its cause in order to avoid the risk of **causing irrevocable damage** to one or several components.

Depending on actual operational constraints and regulatory changes, the installer might recommend increased maintenance operations and more frequent inspections.

WARNING : Isolate unit from power supply before working on unit.

25.1. SERVICING CHECKLIST

Carry out a visual inspection of the complete installation in service.

25.1.1. OUTDOOR UNIT

1. Clean the outer panels.
2. Remove the panels.
3. Check that the insulation is not damaged. Repair as required.

25.1.2. CONDENSATE RECOVERY TRAY

1. Check that the drainage orifices are not blocked.
2. Eliminate all accumulated dirt.
3. Check that no traces of rust are present.

25.1.3. REFRIGERATION CIRCUIT

1. Check the absence of gas leaks.



A control of gas leaks absence should be performed on this device **at least once a year, by a qualified technician**. Referred to national requirements for the frequency of such controls.

2. Check that the copper tubes or the capillary tubes do not rub against any metal or vibrate.
3. Check that the compressors do not generate any abnormal noises or vibrations.
4. Check the compressor discharge temperature.
5. Check that the crankcase heater is energised during the OFF cycle. (Switch on manually if necessary)

25.1.4. FIN EXCHANGER

1. Clean the heat exchanger using a special product for aluminium-copper heat exchangers, and rinse with water. Do not use hot water or steam, as this could cause the pressure of the refrigerant to rise.
2. Check for signs of wear on the fan bearings.
3. Verify the condition of the fans and the motors.

25.1.5. ELECTRICAL EQUIPMENT

Les interventions dans les boîtiers électriques sont réalisées par des techniciens habilités.

1. Check that the main power supply cable is not damaged or altered in such a way as to affect the insulation.
2. Check that the interconnecting cables between the two units are not damaged or altered, and that they are correctly connected.
3. Check the tightness of the screw terminals.
4. Check the general tightness of all cable connections.
5. Perform a visual check of the condition of the contacts.
6. Inspect the relay contact surfaces and the contractors and replace them if necessary.
7. Check nominal current draw and the condition of the fuses.
8. Clean the control box with compressed air to remove any build-ups of dust or dirt.
9. Check the earth grounding connection.

25.1.6. PROTECTION DEVICES

1. Check the proper operation of the high pressure protection devices.

25.1.7. HYDRAULIC CIRCUIT

1. Check that the hydraulic circuit is filled correctly and that the fluid circulates freely without any sign of leaks or air bubbles.
2. Inspect filter cleanliness.
3. Check water pressure and flow.

25.2. INDOOR UNIT CLEANING

Clean the aluminium panels with a micro-fibre cloth and water or a special aluminium cleaning product.

25.3. OUTDOOR UNIT REFRIGERANT CHARGE RECOVERY

In the event of having to store the entire refrigerant charge contained in the Outdoor unit (in the case of work on pipe links between the Indoor and Outdoor units, moving the Outdoor unit...), the charge recovery procedure (pump down procedure) is available in the Maintenance menu. All the details and steps to follow are described on the various "RC" screens. Once the procedure has been completed, almost all the refrigerant charge will be stored in the Outdoor unit.



CAUTION

BEFORE CARRYING OUT ANY OPERATION ON THE EQUIPMENT, CHECK THAT THE ELECTRICAL POWER SUPPLY IS SWITCHED OFF AND THAT IT CANNOT BE SWITCHED ON INADVERTENTLY.

IT IS RECOMMENDED THAT THE DISCONNECT SWITCH BE PADLOCKED

26. ALARM LIST AVAILABLE ON THE AQU@SCOP HT SPLIT DISPLAY



Software version: 6.0

Some terms may differ depending on the software version.

Ref.	Alarm description	AQU@SCOP HT SPLIT action	Alarm cancellation	Time delay	Possible cause(s)	Recommended action(s)
AL01	Entering water temperature sensor disconnected or damaged	Complete shutdown	Manual	10 s	Disconnected or faulty sensor	Check the probe wiring, replace the probe if faulty.
AL02	Leaving water temperature sensor disconnected or damaged	Complete shutdown	Manual	10 s		
AL03	Outdoor temperature sensor disconnected or damaged	Complete shutdown	Manual	10 s		
AL04	Domestic hot water temperature sensor disconnected or damaged	DHW function stopped.	Manual	10 s		
AL05	Deicing temperature sensor (coil bend) disconnected or damaged	Thermodynamic function stopped completely.	Manual	10 s		
AL06	Lack of water flow, freezing risk	Complete stoppage and forced water circulation pump operation during stoppage	Manual	30s after start of circulation pump	Seized water pump Clogged water filter. Water flow too low or air in the system	Check water pump operation Clean the filter. Check the PAC's temperature difference in operation. Increase the flow (change the water pump speed)
AL07	Double zone temperature sensor disconnected or damaged	Radiator zone stoppage, under-floor heating water law, modulating valve 100% open.	Manual	10 s	Probe disconnected or faulty.	Check the probe wiring, replace the probe if faulty.
AL08	Outdoor fans fault	Thermodynamic function stopped completely.	Manual	None	Internal temperature protection cut-out in one of the fans	Reset the alarm after allowing the motors to cool. Check which fan is overheating. Replace the defective fan.
AL09	Compressor 1 / big overload	Automatic changeover to C2 compressor <u>WARNING: De-icing impossible.</u>	Manual (AQU@SCOP HT Split OFF via keypad)	None	Thermo-magnetic circuit breaker tripped (three phase)	Reset the circuit breaker. Check that the setting corresponds to specifications

Ref.	Alarm description	AQU@SCOP HT SPLIT action	Alarm cancellation	Time delay	Possible cause(s)	Recommended action(s)
AL10	Compressor 2 / small overload	Automatic changeover to C1 compressor	Manual (AQU@SCOP HT Split OFF via keypad)	None	Thermo-magnetic circuit breaker tripped (three phase)	Reset the circuit breaker. Check that the setting corresponds to specifications
AL11	High pressure lockout	Complete thermodynamic function stoppage (no manual reset).	Manual (AQU@SCOP HT Split OFF via keypad) after at least 2 minutes stoppage	None	Refer to the fault diagnosis guide in the Installation and Maintenance Manual Water flow too low or air in the system	Refer to the fault diagnosis guide in the Installation and Maintenance Manual Re-establish nominal water flow or bleed the system
AL12	Low pressure lockout	Complete thermodynamic function stoppage (no manual reset).	Manual (AQU@SCOP HT Split OFF via keypad) after at least 2 minutes stoppage	60 s after compressor start-up	Refer to the fault diagnosis guide in the Installation and Maintenance Manual Coil blocked Incomplete de-icing (lack of refrigerant charge)	Refer to the fault diagnosis guide in the Installation and Maintenance Manual Clean the finned coil Check the amount of refrigerant charge
AL13	Internal clock of the controller faulty.	Information	Manual	None	Defective internal regulator clock.	Confirm the problem by switching the mains power on several times. Replace the Indoor unit regulator.
AL14	Both compressor alarm, unit stopped	Complete thermodynamic function stoppage	Manual (AQU@SCOP HT Split OFF via keypad)	None	Both compressors in Alarm mode	Find the cause of the alarm for each compressor
AL16	Comm. loss PAC HT / room terminal, heating forced.	Switchover to forced Heating mode by changing the adjustable ambient temperature (Default setting: 20° C)	Manual	Variable depending on the cause of the problem (clean trip or trip due to electrical interference)	Ambiance terminal is not connected One of the communication cables is disconnected Too much interference on the communication bus	Deactivate it via the AQU@SCOP HT Split keypad Check the connections on the AQU@SCOP HT Split and the terminal as well as the polarities (A and B)
AL17	Phase inversion or one phase missing	Complete shutdown	Manual	None	Power supply fault detection by the phase controller (three phase)	Use shielded cable as recommended Two phases have been inverted or one phase is missing. Refer to the Installation and Maintenance Manual
AL18	Deicing required, compressor 1 / big not available	Complete shutdown	Auto. If outdoor conditions permit natural de-icing	None	There is a fault on the large C1 compressor at a time when it is required by the AQU@SCOP HT Split for de-icing	Rectify the fault on the C1 compressor

Ref.	Alarm description	AQU@SCOP HT SPLIT action	Alarm cancellation	Time delay	Possible cause(s)	Recommended action(s)
AL20	Deicing by evaporating pressure < 0.6bar	De-icing	Automatic after 30 min. compressor operation. D	Variable	Outdoor temperature or De-icing probe defective but undetected. Evaporation pressure sensor defective but undetected. Outdoor temperature too low for Aqu@Scop HT Split operation.	Check the values recorded by the Outdoor and De-icing temperature probes. Replace the probe if necessary. Check the evaporation pressure value in operation. Replace the sensor if necessary.
AL21	2 deicings by evaporating pressure < 0.6bar in 30 minutes	Thermodynamic function stopped completely.			Refrigerant leak. Ineffective de-icing, exchanger blocked. Outdoor temperature too low for Aqu@Scop HT Split operation.	Checked for leaks. Check the refrigerant charge. Clean the fin exchanger.
AL22	Deicing ended abnormally by maximum duration	De-icing stopped	Auto. Alarm displayed for 10 minutes for information purposes	None	De-icing has lasted over 10 minutes. This is abnormal as de-icing usually takes between 3 and 4 minutes	Monitor the appliance to see if this fault is a one-off occurrence, if not, check all possible causes of poor de-icing (lack of refrigerant charge)
AL23	Deicing ended abnormally by leaving water temp. < 10°C	De-icing stopped	Auto. Alarm displayed for 10 minutes for information purposes	None	Outlet water temperature during de-icing has fallen below 10° C	Check that there is sufficient water volume in the system, as recommended in the Installation and Maintenance Manual
AL25	Discharge temperature too high	Thermodynamic function stopped completely.	Manual	None	Cut out by the N°2 compressor outlet temperature probe	Monitor to determine whether this fault is a one-off incident. If not, check the overheating value on the display (may be too high in the event of outflow being cut off).
AL27	Deicing valve failure	Thermodynamic function stopped completely.	Manual (Aqu@Scop HT Split OFF via keypad)	90 s	De-icing valve fault detected automatically by the control system. Valve disconnected, inverted or blocked	Check valve wiring. Activate the Manual controller outputs and check that the valve operates. Replace the valve if the slide is blocked or the coil is burnt out

Ref.	Alarm description	AQU@SCOP HT SPLIT action	Alarm cancellation	Time delay	Possible cause(s)	Recommended action(s)
AL28	Compressor 1 alarm by controller, 2 successive AL34	Automatic changeover to C2 compressor WARNING: De-icing impossible.	Manual (AQU@SCop HT Split OFF via keypad)	90 s	Fault detected automatically by the system management (e.g. when the Temp. difference is too low, indicating that the compressor has not started)	Refer to fault diagnosis guide in the Installation and Maintenance Manual Probable cause: Faulty single phase soft starter, compressor protection fuse melted, excessively low supply voltage or phase missing on the compressor.
AL29	Compressor 2 alarm by controller, 2 successive AL35	Automatic changeover to C1 compressor	Manual (AQU@SCop HT Split OFF via keypad)	90 s	Zero temperature difference during de-icing due to C1 compressor not starting or non activation of the compressor changeover valve. Impossible to determine the cause of the blockage in compressor C1 with certainty	Check that C1 is operating correctly.
AL30	Deicing problem - Compressor 1 or compressor valve	Automatic changeover to C2 compressor	Manual (AQU@SCop HT Split OFF via keypad)	90 s	Alarm generated by the intermediate pressostat. Compressor changeover valve disconnected, blocked or coil burnt out	Check the compressor changeover valve wiring. Activate the Manual controller outputs and check that the valve operates. Replace the valve if the slide is blocked or the coil is burnt out
AL31	Compressor reversing valve failure	Automatic changeover to C2 compressor	Manual (AQU@SCop HT Split OFF via keypad)	10 s	Auto detection by checking whether the water temperature probes are inverted.	Check the compressor changeover valve wiring. Activate the Manual controller outputs and check that the valve operates. Replace the valve if the slide is blocked or the coil is burnt out
AL32	Entering/leaving water sensors reversed	Complete shutdown	Manual (AQU@SCop HT Split OFF via keypad)	90 s	Insufficient water flow in the circuit, flow too low for proper AQU@SCop HT Split operation	Invert the probes at the level of the regulator. Check the probe values when the compressor(s)is/are running.
AL33	$\Delta T > 20^{\circ}\text{C}$, low water flow	Complete thermodynamic function stoppage	Manual (AQU@SCop HT Split OFF via keypad)	90 s	Fault detected automatically by the system management (e.g. when the Temp. difference is too low, indicating that the compressor has not started)	Check that the water flow in the system is always adequate (presence of thermostatic radiator valves) Clean the inlet water filter on the AQU@SCop HT Split
AL34	Compressor 1 alarm by controller (water $\Delta T < 1^{\circ}\text{C}$)	Complete shutdown during 7 minutes. 2 cut-outs  AL28	Automatic	90 s		Refer to fault diagnosis guide in the Installation and Maintenance Manual
AL35	Compressor 2 alarm by controller (water $\Delta T < 1^{\circ}\text{C}$)	Complete shutdown during 7 minutes. 2 cut-outs  AL29	Automatic	90 s		Probable cause: Faulty single phase soft starter, compressor protection fuse melted, excessively low supply voltage or phase missing on the compressor

Ref.	Alarm description	AQU@ScOP HT SPLIT action	Alarm cancellation	Time delay	Possible cause(s)	Recommended action(s)
INF36	--Information-- Backup heater Boiler/ Electric heater enabled	Information	Stop backup mode	None	Activation of the EMH digital input of the controller or backup mode through the display for boiler relief	
AL39	Water pressure < 0.5bar in the heating circuit	Information	Pressure > 1 bar for 5s.	10 s	Insufficient water pressure in the Heating circuit.	Add water to the heating circuit. Check proper expansion tank operation. Check for leaks on the Heating network.
AL40	No communication with the outdoor unit	Complete thermodynamic function stoppage	Manual and Com OK for 22s.	22s	Incorrect wiring. Communication bus cable cut. Unshielded cable. Outdoor unit not auto-detected.	Check bus connections at both ends. Check the condition of the bus cable Install shielded cable. Check the wiring of the Outdoor unit probes.
AL41	¹ Aqu@ScOP HT Split unit not recognized on the communication bus	Information	Automatic	None	Probes B1 to B4, B8 and B9 partially or totally disconnected on the unit in question.	Check the probe values on the display and check the probe connections.
AL42	Indoor/outdoor units software versions incompatible	Complete thermodynamic function stoppage	Power supply cut.	None	Different versions for Indoor and Outdoor units.	Update the programme for both units.
AL43	No Aqu@ScOP HT Split model detected Split or Monobloc	Complete stoppage.	Power supply cut.	None	Probes B1 to B4, B8 and B9 partially or totally disconnected on the unit in question. Probes B1 to B4, B8 and B9 partially or totally disconnected on the unit in question => incorrect model detection	Check the probe values on the display and check the probe connections. Check the probe values on the display and check the probe connections.
AL44	Aqu@ScOP HT Split model modified for the indoor unit	Information		None	μ PC replaced by that of another Aqu@ScOP HT Split (Split Indoor/Outdoor /Monobloc) Programme taken from another Aqu@ScOP HT Split (Split Indoor/Outdoor/Monobloc)	Confirm once the situation is understood.

Ref.	Alarm description	AQU@SCOP HT SPLIT action	Alarm cancellation	Time delay	Possible cause(s)	Recommended action(s)
AL45	Aqu@ScOP HT Split model modified for the outdoor unit	Information		None	Probes B1 to B4, B8 and B9 partially or totally disconnected on the unit in question => incorrect model detection µPC replaced by that of another Aqu@ScOP HT (Split Indoor/Outdoor /Monobloc) Programme taken from another Aqu@ScOP HT (Split Indoor/Outdoor/Monobloc).	Check the probe values on the display and check the probe connections. Confirm once the situation is understood.
AL46	Size modified for the outdoor unit	Information		None	Modification of the wiring of the analogue inputs B5 and B12 of the Outdoor unit configuration. Programme or µPC replaced by another Outdoor unit.	Check the status and the wiring of B5 and B12 Confirm once the situation is understood.
AL47	Different indoor and outdoor unit sizes	Information		None	Different Indoor and Outdoor unit sizes.	Check the sizes and their correspondence on the makers plates. Check the status and the wiring of inputs B5 and B12 on the Outdoor unit.
AL48	Water flow meter disconnected or damaged	Complete stoppage.	Manual	10 s	Flow meter disconnected or faulty. Faulty 0-5V supply.	Check the wiring of the flow meter, replace the flow meter if it is faulty. Measure the 0-5V voltage.
AL49	Water pressure sensor disconnected or damaged	Information	Manual	10 ss	Water pressure sensor disconnected or damaged. Faulty 0-5V supply.	Check the sensor wiring, replace the sensor if it is faulty. Measure the 0-5V voltage.
AL50	Compressor discharge sensor disconnected or damaged	Complete thermodynamic function stoppage	Manual	10 s	Probe disconnected or damaged.	Check the probe wiring, replace the probe if it is faulty.
AL51	Evaporating temperature sensor disconnected or damaged	Complete thermodynamic function stoppage	Manual	10 s	Probe disconnected or damaged.	Check the probe wiring, replace the probe if it is faulty.

Ref.	Alarm description	AQU@SCOP HT SPLIT action	Alarm cancellation	Time delay	Possible cause(s)	Recommended action(s)
AL52	Evaporating pressure sensor disconnected or damaged	Complete thermodynamic function stoppage	Manual	10 s	Transducer disconnected or damaged.	Check the transducer wiring, replace the transducer if it is faulty.
INF56	Software updated or new controller in the indoor unit	Information	Manual	None	Programme update or μ PC replaced in the Indoor unit.	Confirm once the situation is understood.
INF57	Software updated or new controller in the outdoor unit	Information	Manual	None	Programme update or μ PC replaced in the Outdoor unit.	Confirm once the situation is understood.
INF58	No indoor unit size in controller memory	Information	Manual	None	Programme update or μ PC replaced in the Indoor unit.	Check the size of the Indoor unit on the makers plate. Key in the details and then confirm
AL59	Swimming pool sensor disconnected or damaged	Swimming pool function stopped.	Manual	10 s	Probe disconnected or damaged.	Check the probe wiring, replace the probe if it is faulty.
AL76	PAC HT stopped by outdoor temperature too high	Complete thermodynamic function stoppage	Automatic	None	Outdoor temperature too high (> 40°C) for Heating or DHW operation.	Wait until the outdoor temperature drops (restart value visible on the alarm screen).

General comments:

- If you have a doubt about a **Aqu@Scop HT Split** component, use the Manual activation function for the outputs (all the all or nothing outputs excluding the compressors) via the "INSTALLATION" menu on the appliances display. Use a voltmeter to check that the regulator output is activated (230V) and that the component is question is also activated.
- The **Aqu@Scop HT Split** retains a very comprehensive log of alarms, i.e. the 150 last alarms, as well as temperature probe values (water inlet and outlet, outdoor and outdoor battery) when the alarm appears. You can access this log from the main menu (sub-menu "Alarm log"). Press the ENTER () key to switch back and forth between the log screen and the probes screen.

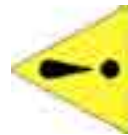
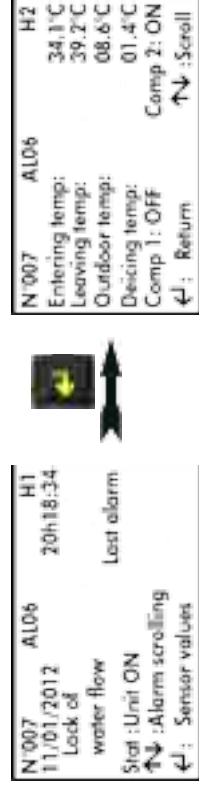

Generally, an alarm means that there is an anomaly with the appliance. We strongly **advise against** repeatedly resetting an alarm at the risk of causing **irreparable damage** to one or several components.

27. FAULTY DIAGNOSIS GUIDE

Simple diagnosis advice. In the event of a breakdown, you should contact your local after sales department for confirmation and assistance.

Compressor does not start		
Problem symptoms	Probable cause	Recommended action
Power is present at the compressor terminal but the motor does not rotate	Motor burnt out	Replace the compressor
Motor contactor inoperable	Coil burnt out or contacts broken	Repair or replace the contactor
No current upstream of the motor contactor	Circuit breaker tripped	Check the fuses / thermo-magnetic circuit breakers and electrical connections
Current upstream of the fuse, but not on the contactor side	Fuse blown or thermo-magnetic circuit breaker tripped	Replace the fuse. Reset the thermo-magnetic circuit breaker Check current values
Low voltage measured on voltmeter	Voltage too low	Contact your electricity supplier
No power supply to contactor coil	Regulation open circuit	Use the appliance display to check that the system is actually calling for compressor operation
Compressor operates but current draw is abnormally high	Compressor damaged	Replace the compressor
"Growling" compressor motor	Excessive output pressure Abnormally low voltage on start-up in single phase	Check the supply voltage. Refer to the single phase soft start faults chart Check the controller control relays and their wiring (refer to wiring diagrams)

Compressor stops.		
Problem symptoms	Probable cause	Recommended action
HP pressostat triggered	Excessively high outlet pressure	Refer to instructions provided for "high outlet pressure"
Discharge thermostat triggered	Lack of refrigerant fluid	Repair the leak. Add refrigerant fluid or completely replace the charge
	Abnormal Compressor superheat	Set the superheat on the expansion valve
	Defective de-icing	Check proper de-icing operation
Inlet pressure too low	Dryer filter blocked	Replace dryer filter
	Lack of refrigerant fluid	Repair the leak. Add refrigerant fluid or completely replace the charge
	Faulty expansion valve	Replace the expansion valve
	Abnormal icing up of finned exchanger	Check proper operation of de-icing function
Dryer filter iced up	Blocked dryer filter	Replace the dryer filter

Compressor lubrication problem		
Problem symptoms	Probable cause	Recommended action
Noisy compressor	Fault in oil equalisation system	Check operation of the oil equalisation valve. Contact your After Sales Service

Excessively high discharge pressure		
Problem symptoms	Probable cause	Recommended action
Major difference between condensing and water outlet temperatures	Presence of incondensable matter in the system or excessive refrigerant fluid charge Presence of air in water circuit	Bleed the incondensable matter and drain off the excess refrigerant fluid Bleed the air from the circuit
High output pressure and very high water ΔT	Insufficient water flow	Flow meter control Ensure that there is an adequate water flow through the entire system

Excessively high inlet pressure		
Problem symptoms	Probable cause	Recommended action
Presence of liquid in the intake line	Expansion valve open too far	Check the overheating value on the display. Check the position of the pressure sensor and the evaporation temperature probe. Check the values present on the display.
Refrigerant fluid flow back towards the compressor, irrespective of the expansion valve setting	Expansion valve blocked in open position	Inspect the electronic regulator wiring on the Outdoor unit regulator. Replace the regulator if it does not react when mains power is switched on to the unit.

Excessively low inlet pressure		
Problems - symptoms	Probable cause	Recommended action
Excessive pressure loss across the dryer filter	Clogged dryer filter	Replace the dryer filter
Refrigerant does not pass through the electronic pressure relief valve, irrespective of the regulator settings.	The electronic pressure relief valve is faulty.	Replace the electronic pressure relief valve.
	The electronic pressure relief valve is disconnected from the Outdoor unit's regulator	Reconnect the electronic pressure relief valve wiring.
Loss of power	Expansion valve blocked	Replace the expansion valve
	Lack of refrigerant fluid	Repair the leak. Add refrigerant fluid or completely replace the charge
	Evaporator blocked	Clean the finned evaporator
	Insufficient air flow	Check proper operation of the fan/motor units
	Defective de-icing	Check proper operation of de-icing function

APPENDIX
ANNEXE
ANLAGE
ALLEGATO
ANEXO

APPENDIX

DIMENSIONS	III
REFRIGERATION AND HYDRAULIC LINKS DIAGRAM	V
REFRIGERANT CONNECTIONS	VII
WATER FLOW CALCULATION GRAPH	VIII
WIRING DIAGRAM	IX
AQU@SCOP HT SPLIT 12-6 230V +/-10% 50HZ.....	X
AQU@SCOP HT SPLIT 14-7 230V +/-10% 50HZ.....	XII
AQU@SCOP HT SPLIT 12-6 3N~400V +/-10% 50HZ.....	XIV
AQU@SCOP HT SPLIT 14-7 3N~400V +/-10% 50HZ.....	XV
AQU@SCOP HT SPLIT 12-6 / 14-7 3N~400V +/-10% 50HZ.....	XVI
AQU@SCOP HT SPLIT 18-9 3N~400V +/-10% 50HZ.....	XVII
AQU@SCOP HT SPLIT INDOOR UNIT.....	XIX
DOMESTIC HOT WATER TANK	XX
ADDITIONAL ELECTRIC HEATER	XX

ANNEXE

DIMENSIONS	III
SCHEMA FRIGORIFIQUE ET HYDRAULIQUE	V
RACCORDEMENTS FRIGORIFIQUES	VII
ABAQUE DE CALCUL DE DEBIT D'EAU	VIII
SCHEMAS ELECTRIQUES	IX
AQU@SCOP HT SPLIT 12-6 230V +/-10% 50HZ.....	X
AQU@SCOP HT SPLIT 14-7 230V +/-10% 50HZ.....	XII
AQU@SCOP HT SPLIT 12-6 3N~400V +/-10% 50HZ.....	XIV
AQU@SCOP HT SPLIT 14-7 3N~400V +/-10% 50HZ.....	XV
AQU@SCOP HT SPLIT 12-6 / 14-7 3N~400V +/-10% 50HZ.....	XVI
AQU@SCOP HT SPLIT 18-9 3N~400V +/-10% 50HZ.....	XVII
AQU@SCOP HT SPLIT INDOOR UNIT.....	XIX
BALLON D'EAU CHAUDE SANITAIRE	XX
CHAUFFAGE ELECTRIQUE ADDITIONNEL.....	XX

ANLAGE

ABMESSUNGEN	III
KÜHL- UND HYDRAULIKDIAGRAMM	V
KÄLTETECHNISCHANSCHLÜSSE	VII
BERECHNUNGSKURVE DER WASSERDURCHFLUSSMENGE	VIII
STROMLAUFPLANS	IX
AQU@SCOP HT SPLIT 12-6 230V +/-10% 50HZ.....	X
AQU@SCOP HT SPLIT 14-7 230V +/-10% 50HZ.....	XII
AQU@SCOP HT SPLIT 12-6 3N~400V +/-10% 50HZ.....	XIV
AQU@SCOP HT SPLIT 14-7 3N~400V +/-10% 50HZ.....	XV
AQU@SCOP HT SPLIT 12-6 / 14-7 3N~400V +/-10% 50HZ.....	XVI
AQU@SCOP HT SPLIT 18-9 3N~400V +/-10% 50HZ.....	XVII
AQU@SCOP HT SPLIT INDOOR UNIT.....	XIX
BRAUCHWASSERVERSORGUNG	XX
ZUSÄTZLICHE ELEKTROHEIZUNG	XX

ALLEGATO

DIMENSIONI	III
SCHEMA FRIGORIFERO ED IDRAULICO	V
COLLEGAMENTI FRIGORIFERI	VII
ABACO DI CALCOLO DELLA PORTATA DELL'ACQUA	VIII
SCHEMA ELETRICO	IX
AQU@SCOP HT SPLIT 12-6 230V +/-10% 50HZ.....	X
AQU@SCOP HT SPLIT 14-7 230V +/-10% 50HZ.....	XII
AQU@SCOP HT SPLIT 12-6 3N~400V +/-10% 50HZ.....	XIV
AQU@SCOP HT SPLIT 14-7 3N~400V +/-10% 50HZ.....	XV
AQU@SCOP HT SPLIT 12-6 / 14-7 3N~400V +/-10% 50HZ.....	XVI
AQU@SCOP HT SPLIT 18-9 3N~400V +/-10% 50HZ.....	XVII
AQU@SCOP HT SPLIT INDOOR UNIT.....	XIX
PALLA DI ACQUA CALDA SANITARIA	XX
RESISTENZE ELETTRICHE ADDIZIONALE	XX

ANEXO

DIMENSIONES	III
ESQUEMA FRIGORÍFICO E HIDRÁULICO	V
CONEXIONES FRIGORÍFICA	VII
ÁBACO DE CÁLCULO DE CAUDAL DE AGUA	VIII
ESQUEMA ELECTRICO	IX
AQU@SCOP HT SPLIT 12-6 230V +/-10% 50HZ.....	X
AQU@SCOP HT SPLIT 14-7 230V +/-10% 50HZ.....	XII
AQU@SCOP HT SPLIT 12-6 3N~400V +/-10% 50HZ.....	XIV
AQU@SCOP HT SPLIT 14-7 3N~400V +/-10% 50HZ.....	XV
AQU@SCOP HT SPLIT 12-6 / 14-7 3N~400V +/-10% 50HZ.....	XVI
AQU@SCOP HT SPLIT 18-9 3N~400V +/-10% 50HZ.....	XVII
AQU@SCOP HT SPLIT INDOOR UNIT.....	XIX
ACUMULADOR DE AGUA CALIENTE SANITARIA.....	XX
CALEFACCION ELECTRICA ADICIONAL	X

DIMENSIONS
 DIMENSIONS
 ABMESSUNGEN
 DIMENSIONI
 DIMENSIONES

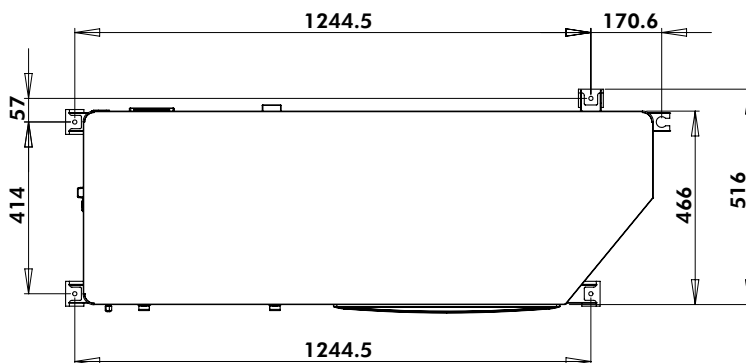
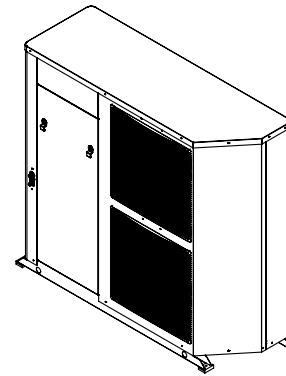
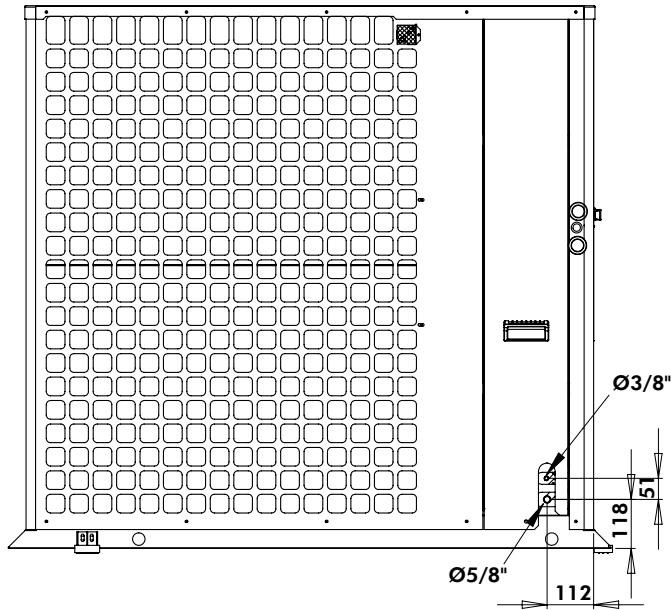
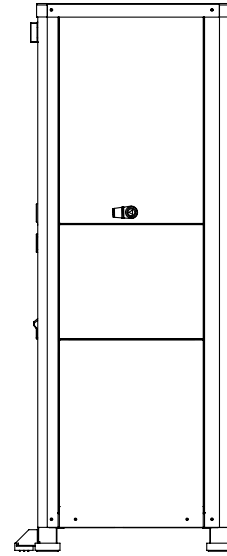
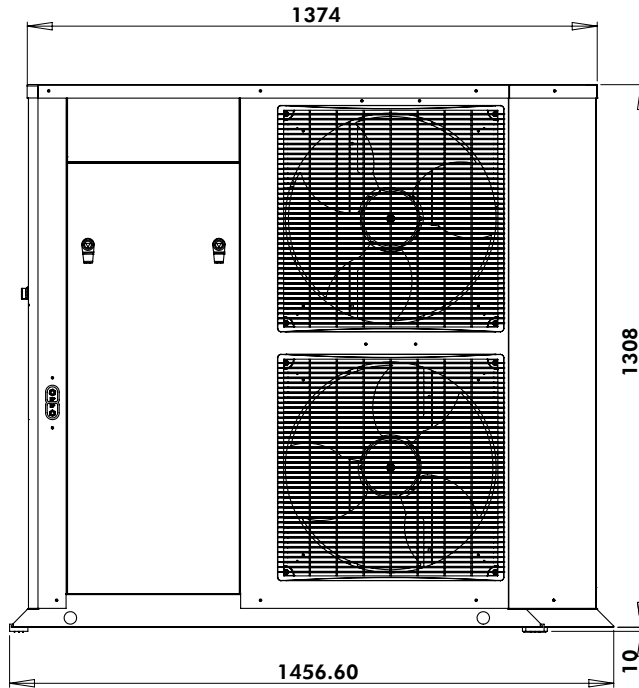

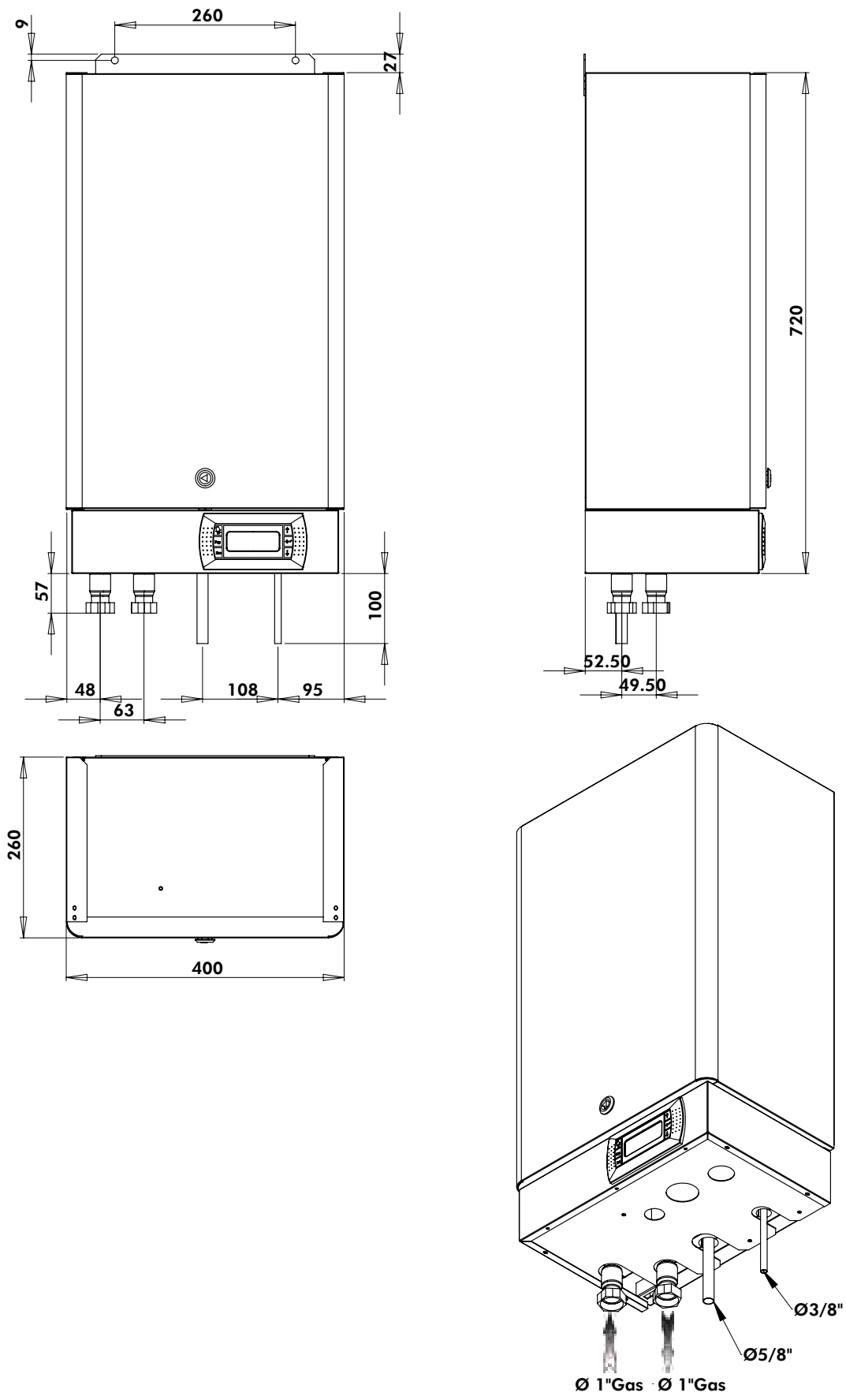

**REFRIGERATION AND HYDRAULIC LINKS DIAGRAM
SCHEMA FRIGORIFIQUE ET HYDRAULIQUE
KÜHL- UND HYDRAULIKDIAGRAMM
SCHEMA FRIGORIFERO ED IDRAULICO
ESQUEMA FRIGORÍFICO E HIDRÁULICO**

1 Large compressor
2 Small compressor
3 Plate heat exchangers. Counter-current heating
4 Liquid tank
5 Plate heat exchangers. economiser
6 Finned heat exchanger and fans
7 Circulation pump
8 Oil separator
9 Dehydrator filter
10 Liquid warning light
11 Non-return valve
12 Automatic bleed
13 Flowmeter
V1 Four-way valve
V2 Four-way valve
V3 Injection electrovalve
V4 Electrovalve
V5 Injection expansion valve
V6 Electronic expansion valve
V7 Safety valve (3 bar)
P1 High Pressure safety pressostat
P2 High Pressure pressostat
P3 Defrost system high pressure control pressostat
P4 Evaporation pressure probe
P5 Water pressure probe
P Pressure take-off
CDT Outlet temperature probe
CST Evaporation temperature probe
LWT Water temperature probe (outlet)
EWT Water temperature probe (inlet)
OCT Outdoor coil temperature probe
OAT Outdoor air temperature probe

1 Gros compresseur
2 Petit compresseur
3 Echangeur à plaques Contre courant chauffage
4 Réservoir liquide
5 Echangeur à plaques. économiseur
6 Echangeur à ailettes et ventilateurs
7 Circulateur
8 Séparateur d'huile
9 Filtre déshydrateur
10 Voyant liquide
11 Clapet anti-retour
12 Purgeur automatique
13 Débitmètre
V1 Vanne 4 voies
V2 Vanne 4 voies
V3 Electrovanne d'injection
V4 Electrovanne
V5 Détendeur d'injection
V6 Détendeur électronique
V7 Soupape sécurité (3 bar)
P1 Pressostat sécurité haute pression
P2 Pressostat haute pression intermédiaire
P3 Pressostat contrôle haute pression dégivrage
P4 Capteur de pression d'évaporation
P5 Capteur de pression d'eau
P Prise de pression
CDT Sonde de température de refoulement
CST Sonde de température d'évaporation
LWT Sonde de température d'eau (sortie)
EWT Sonde de température d'eau (entrée)
OCT Sonde contrôle de condensation
OAT Sonde de température d'air extérieure

1 Kompressor Niederdruck
2 Kompressor Hochdruck
3 Plattenwärmeaustauscher. Gegenstrom Heizung
4 Flüssigkeitsbehälter
5 Plattenwärmeaustauscher. economiser
6 Lamellenwärmetauscher und Ventilatoren
7 Umlaufpumpe
8 Olabscheider
9 Filtertrockner
10 Anzeigelampe Flüssigkeit
11 Rückschlagklappe
12 Automatischer Ablasshahn
13 Durchflussmesser
V1 Vierwegventil
V2 Vierwegventil
V3 Injektionelektroventil
V4 Elektroventil
V5 Expansionsventil Injektion
V6 Elektronisches Minderventil
V7 Sicherheitsventil (3 Bar)
P1 Hochdruck-Sicherheitspressostat
P2 Hochdruck-Pressostat
P3 Hochdruckkontrollpressostat Abtauen
P4 Verdampfungsdrucksensor
P5 Wasserdrucksensor
P Druckanschluss
CDT Fördertemperatursensor
CST Verdampfungsstempersensor
LWT Wassertemperaturfühler (Austritt)
EWT Wassertemperaturfühler (Eintritt)
OCT Messfühler Verflüssigungskontrolle
OAT Lufttemperaturfühler

1 Compresor baja presión
2 Compresor alta presión
3 Scambiatori di calore a piastre Contracorriente calefacción
4 Depósito líquido
5 Scambiatori di calore a piastre economizzatore
6 Intercambiador de aletas y ventiladores
7 Circulador
8 Separatore d'olio
9 Filtro deshidratador
10 Spia liquido
11 Valvola antirritorno
12 Purgador automático
13 Flussometro
V1 Valvola a quattro vie
V2 Valvola a quattro vie
V3 Elettrovalvola di iniezioni
V4 Elettrovalvola
V5 Válvula de expansión de iniezioni
V6 Riduttore di pressione elettronico
V7 Válvula de seguridad (3 bares)
P1 Presostato de seguridad alta presión
P2 Presostato alta presión
P3 Presostato de control alta presión descongelación
P4 Sensore di pressione dell'evaporazione
P5 Sensore di pressione dell'acqua
P Presa di pressione
CDT Sonda di temperatura di espulsione
CST Sonda di temperatura di evaporazione
LWT Sonda de temperatura de agua (salida)
EWT Sonda de temperatura de agua (entrada)
OCT Sonda controllo di condensazione
OAT Sonda de temperatura de aire

1 Compresore bassa pressione
2 Compresore alta pressione
3 Intercambiador térmico de placas Contracorriente riscaldamento
4 Serbatoio liquido
5 Intercambiador térmico de placas economizador
6 Scambiatore ad alette e ventilatori
7 Circolatore
8 Separador de aceite
9 Filtro disidratante
10 Indicador luminoso líquido
11 Válvula antirretorno
12 Valvola di scarico automatica
13 Flujómetro
V1 Válvula de cuatro vías
V2 Válvula de cuatro vías
V3 Electroválvula de inyección
V4 Electroválvula
V5 Valvola d'espansione de inyección
V6 Reductor electrónico
V7 Valvola di sicurezza (3 bar)
P1 Pressostato sicurezza alta pressione
P2 Pressostato alta pressione
P3 Pressostato controllo alta pressione sbrinamento
P4 Captador de presión de evaporación
P5 Captador de presión de agua
P Toma de presión
CDT Sonda de temperatura de descarga
CST Sonda de temperatura de evaporación
LWT Sonda di temperatura acqua (uscita)
EWT Sonda di temperatura acqua (ingresso)
OCT Sonda de control de condensación
OAT Sonda di temperatura aria

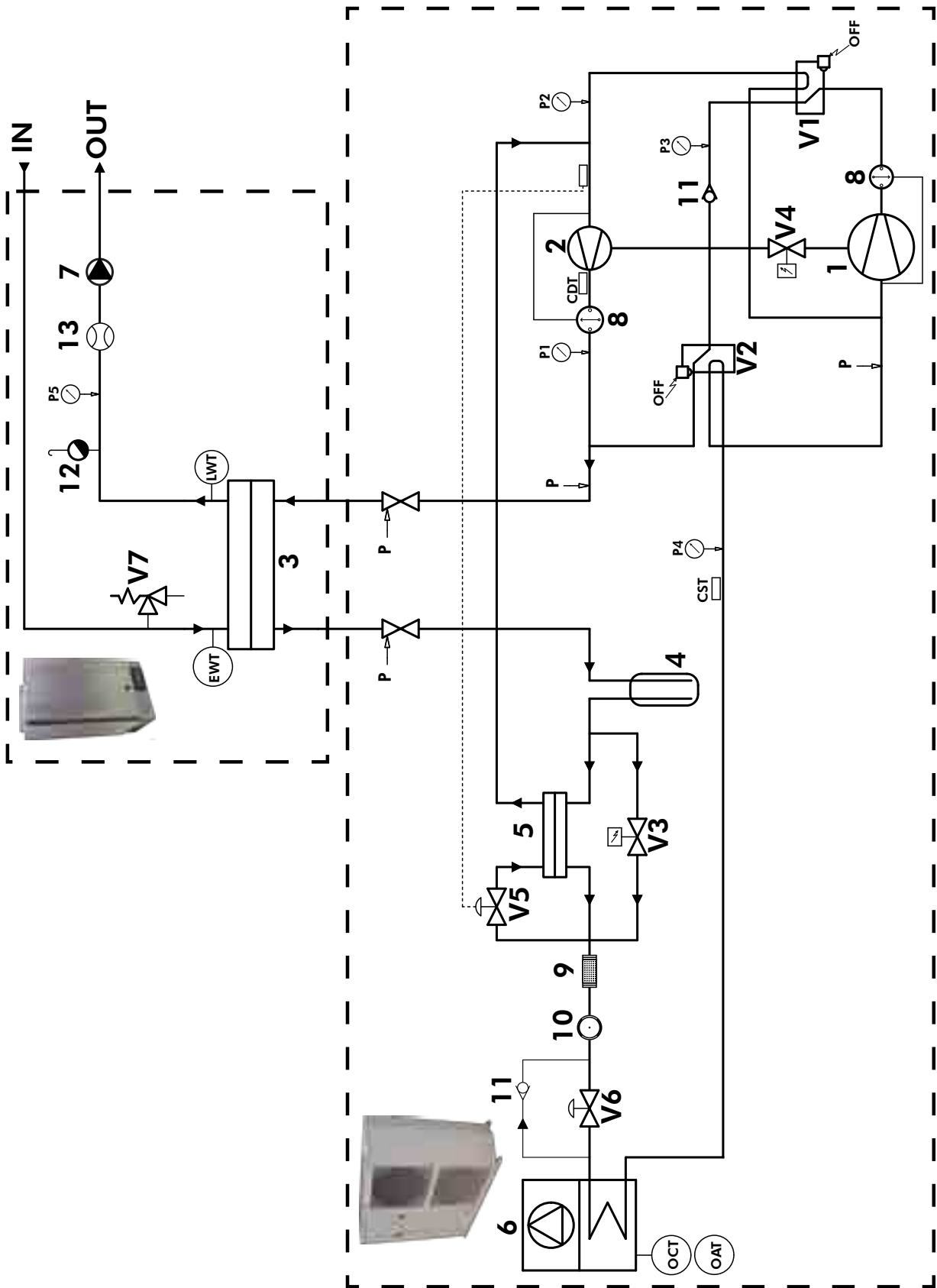

REFRIGERANT CONNECTIONS
 RACCORDEMENTS FRIGORIFIQUES
 KÄLTETECHNISCHANSCHLÜSSE
 COLLEGAMENTI FRIGORIFERI
 CONEXIONES FRIGORÍFICA

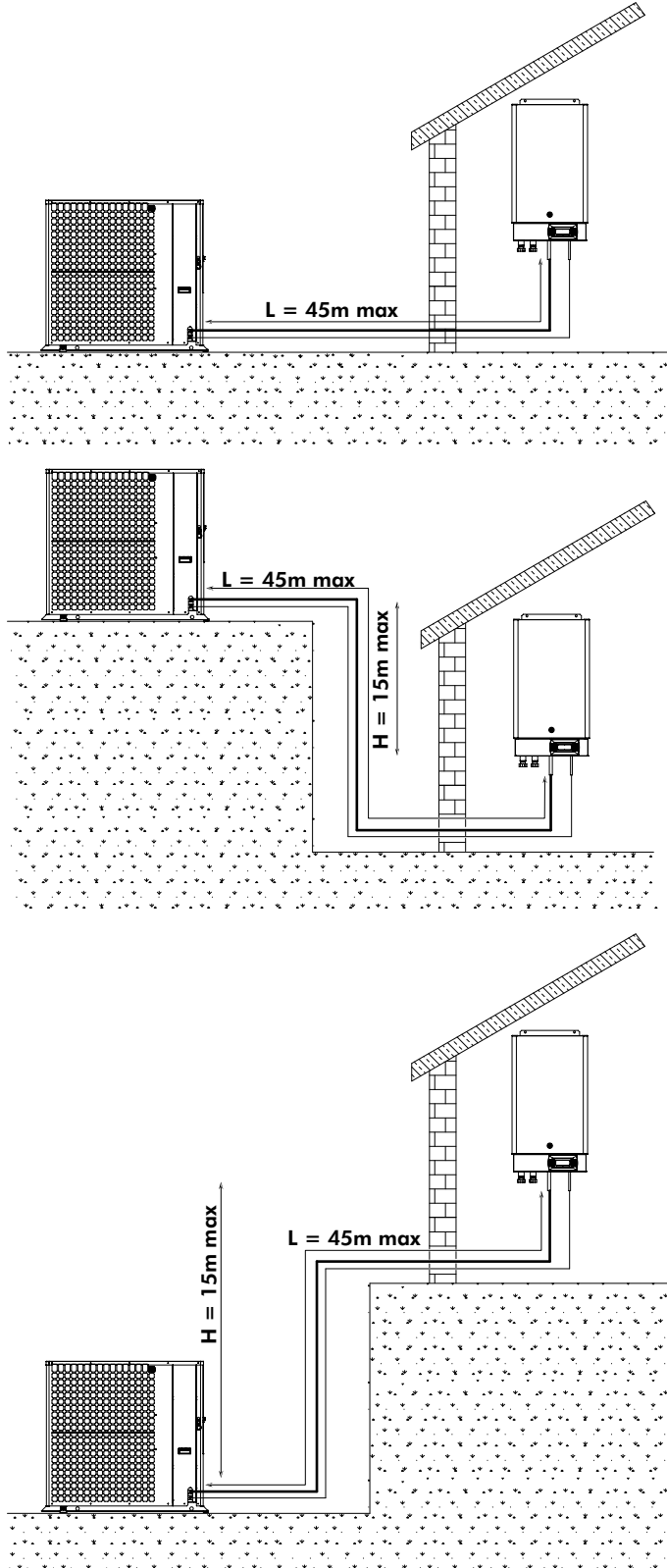

L (m)	Ø A - Ø B (")	Additional charge (g) Charge complémentaire (g) Zusätzliche Ladung (g) Carica aggiuntiva (g) Carga complementaria (g)
20	5/8 - 3/8	0
21		57
22		114
23		171
24		228
25	285	
26	3/4 - 1/2	1792
27		1904
28		2016
29		2128
30		2240
31		2352
32		2464
33		2576
34		2688
35		2800
36		2912
37		3024
38		3136
39		3248
40		3360
41	3472	
42	3584	
43	3696	
44	3808	
45	3920	

A
 Gas pipe
 Ligne gaz
 Verbindungleitungen Gas
 Collegamentogas
 Conexión gas

B
 Liquid pipe
 Ligne liquide
 Verbindungsleitung Flüssigkeit
 Collegamento liquido
 Conexión líquido

**WATER FLOW CALCULATION GRAPH
 ABAQUE DE CALCUL DE DEBIT D'EAU
 BERECHNUNGSKURVE DER WASSERDURCHFLUSSMENGE
 ABACO DI CALCOLO DELLA PORTATA DELL'ACQUA
 ÁBACO DE CÁLCULO DE CAUDAL DE AGUA**

Aqu@Scop HT SPLIT 12-6

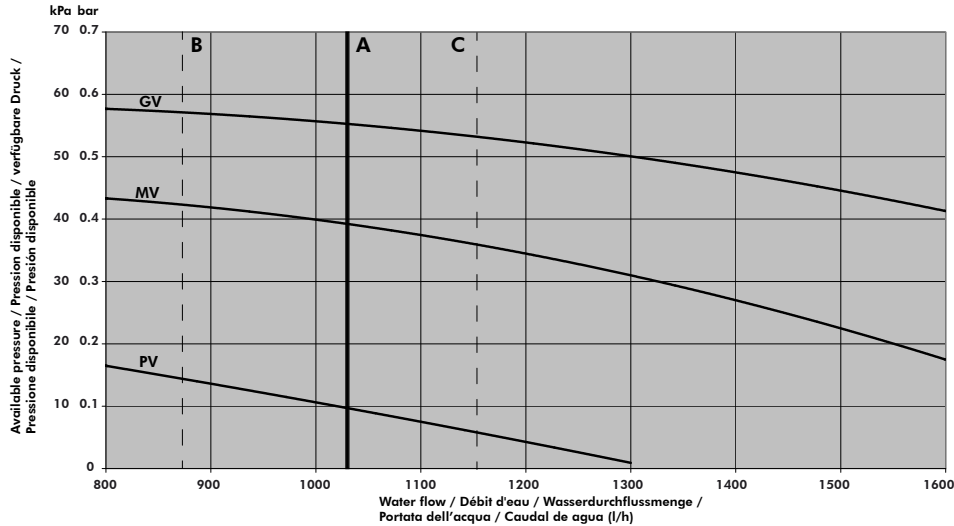

- A** Nominal flow
- B** Minimal flow
- C** Maximal flow

Aqu@Scop HT SPLIT 14-7

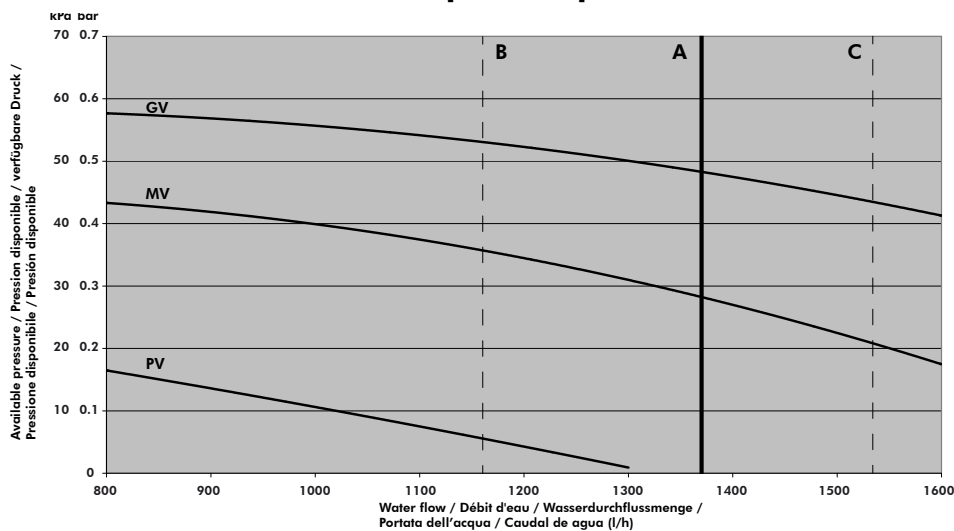

- A** Débit nominal
- B** Débit minimal
- C** Débit maximal
- A** Nenndurchflussmenge
- B** Minimaler Absatz
- C** Maximaler Absatz
- A** Portata nominale
- B** Portata Minimo
- C** Portata massimo

Aqu@Scop HT SPLIT 18-9

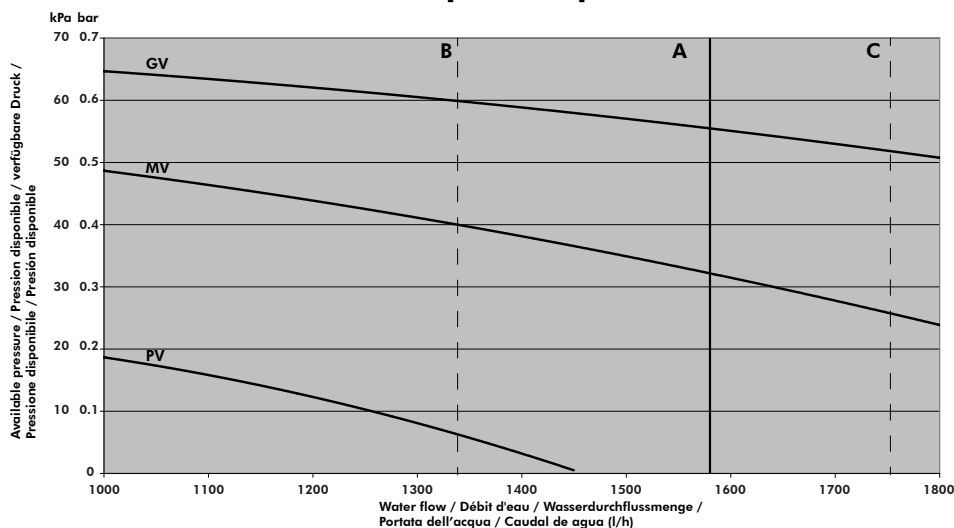

- A** Caudal nominal
- B** Caudal mínimo
- C** Caudal máximo

**WIRING DIAGRAM
SCHEMAS ELECTRIQUES
STROMLAUFPLANS
SCHEMA ELETRICO
ESQUEMA ELECTRICO**

TAKE CARE!

These wiring diagrams are correct at the time of publication. Manufacturing changes can lead to modifications. Always refer to the diagram supplied with the product.

ATTENTION

Ces schémas sont corrects au moment de la publication. Les variantes en fabrication peuvent entraîner des modifications. Reportez-vous toujours au schéma livré avec le produit.

ACHTUNG!

Diese Stromlaufplans sind zum Zeitpunkt der Veröffentlichung gültig. In Herstellung befindliche Varianten können Änderungen mit sich bringen. In jedem Fall den mit dem Produkt gelieferten Stromlaufplan hinzuziehen.

ATTENZIONE !

Questi schemi sono corretti al momento della pubblicazione. Le varianti apportate nel corso della fabbricazione possono comportare modifiche. Far sempre riferimento allo schema fornito con il prodotto.

ATENCIÓN !

Esto esquemas son correctos en el momento de la publicación. Pero las variantes en la fabricación pueden ser motivo de modificaciones. Remítase siempre al esquema entregado con el producto.

**POWER SUPPLY MUST BE SWITCHED OFF BEFORE STARTING TO
WORK IN THE ELECTRIC CONTROL BOXES!**



**MISE HORS TENSION OBLIGATOIRE AVANT TOUTE INTERVENTION
DANS LES BOITIERS ELECTRIQUES.**

**VOR JEDEM EINGRIFF AN DEN ANSCHLUßKÄSTEN UNBEDINGT
DAS GERÄT ABSCHALTEN!**

**PRIMA DI OGNI INTERVENTO SULLE CASSETTE ELETTRICHE
ESCLUDERE TASSATIVAMENTE L'ALIMENTAZIONE !**

**PUESTA FUERA DE TNESIÓN OBLIGATORIA ANTES DE CUALQUIER
INTERVENCIÓN EN LAS CAJAS ELÉCTRICAS!**

APPENDIX / ANNEXE / ANLAGE / ALLEGATO / ANEXO

AQU@SCOP HT SPLIT 12-6 230V +/-10% 50HZ

CONTROL WIRING DIAGRAM	
AQU@SCOP HT SPLIT (12-6) 230V OUTDOOR UNIT	
SE 4164	3991224
LEGEND N 791	

BK	BLACK
BN	BROWN
BRN	BROWN
BNVE	GREEN/YELLOW
GY	GREY
OR	ORANGE
OG	RED
RD	RED
VT	VIOLET
WH	WHITE

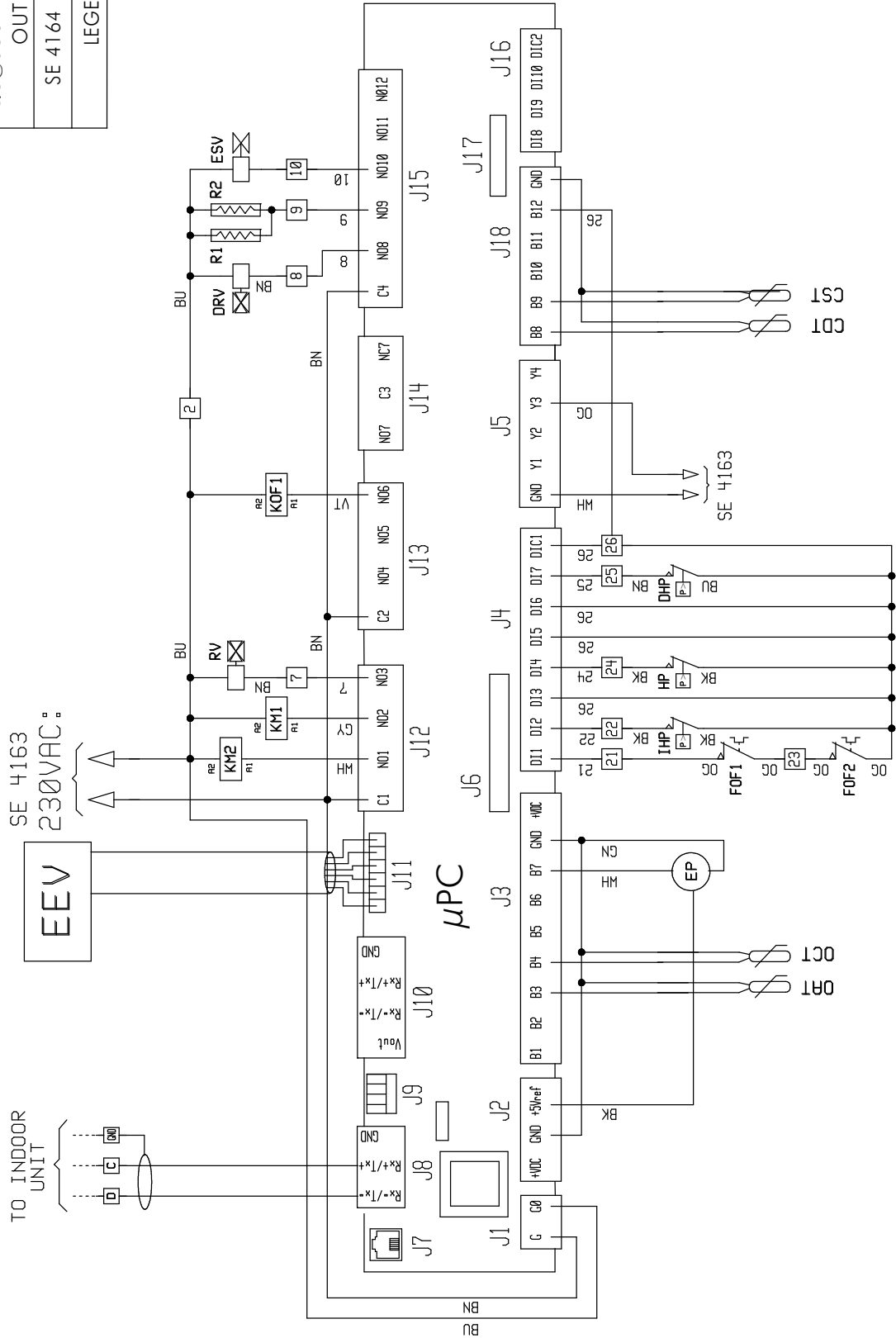

POWER WIRING DIAGRAM	
AGU@SCOP HT SPLIT (12-6) 230V OUTDOOR UNIT	
SE 4163	3991223
LEGEND N 791	

BK	BLACK
BRN	BROWN
BU	BLUE
GYE	GREEN/YELLOW
OG	ORANGE
RD	RED
VT	VIOLET
WH	WHITE

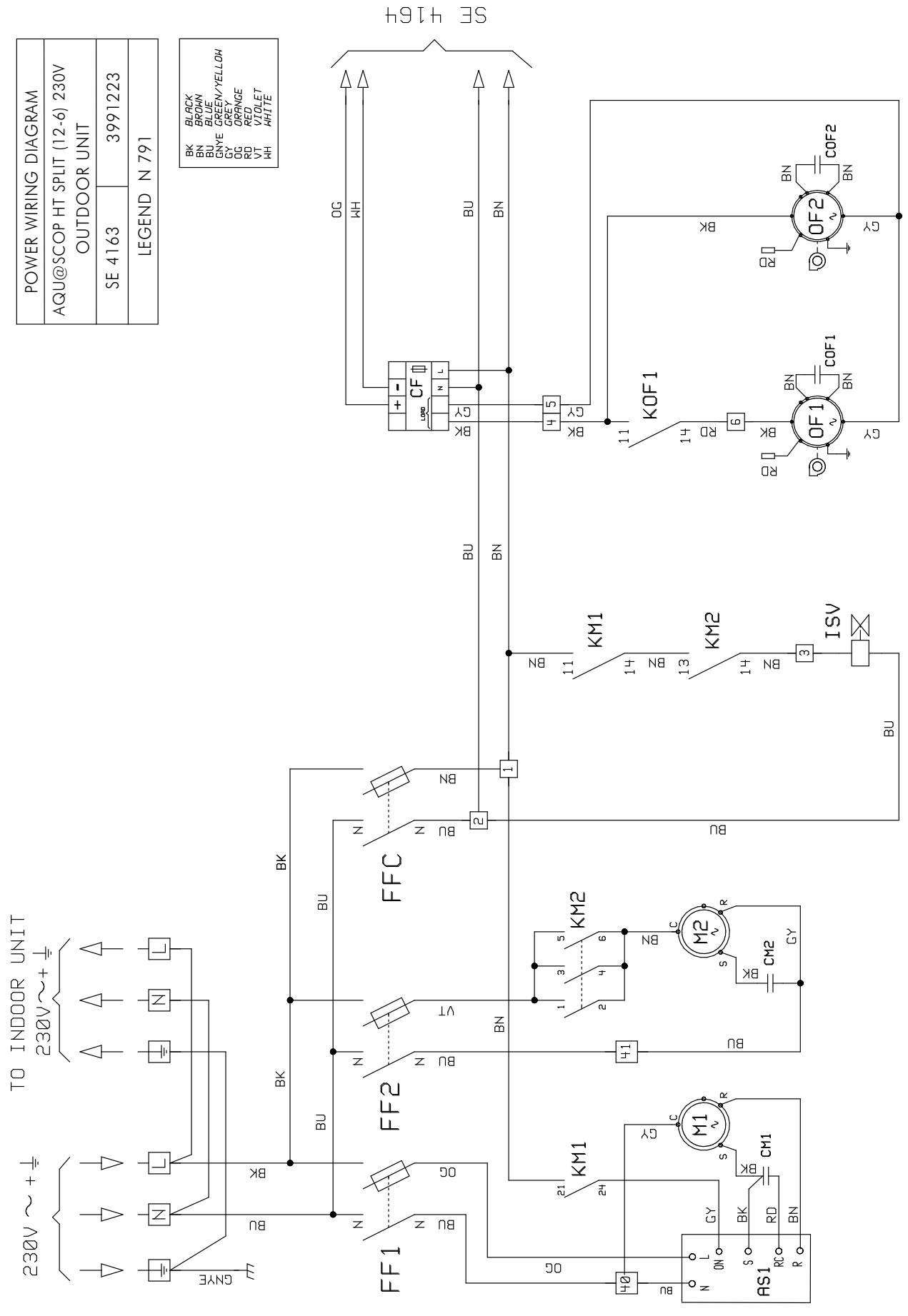

APPENDIX / ANNEXE / ANLAGE / ALLEGATO / ANEXO

AQU@SCOP HT SPLIT 14-7 230V +/-10% 50HZ

CONTROL WIRING DIAGRAM	
AQU@SCOP HT SPLIT (14-7) 230V OUTDOOR UNIT	
SE 4166	3991226
LEGEND N 791	

BK	BLACK
BN	BROWN
BU	BLUE
BY	GREEN/YELLOW
CG	GREEN
OG	ORANGE
RD	RED
VT	VIOLET
WH	WHITE

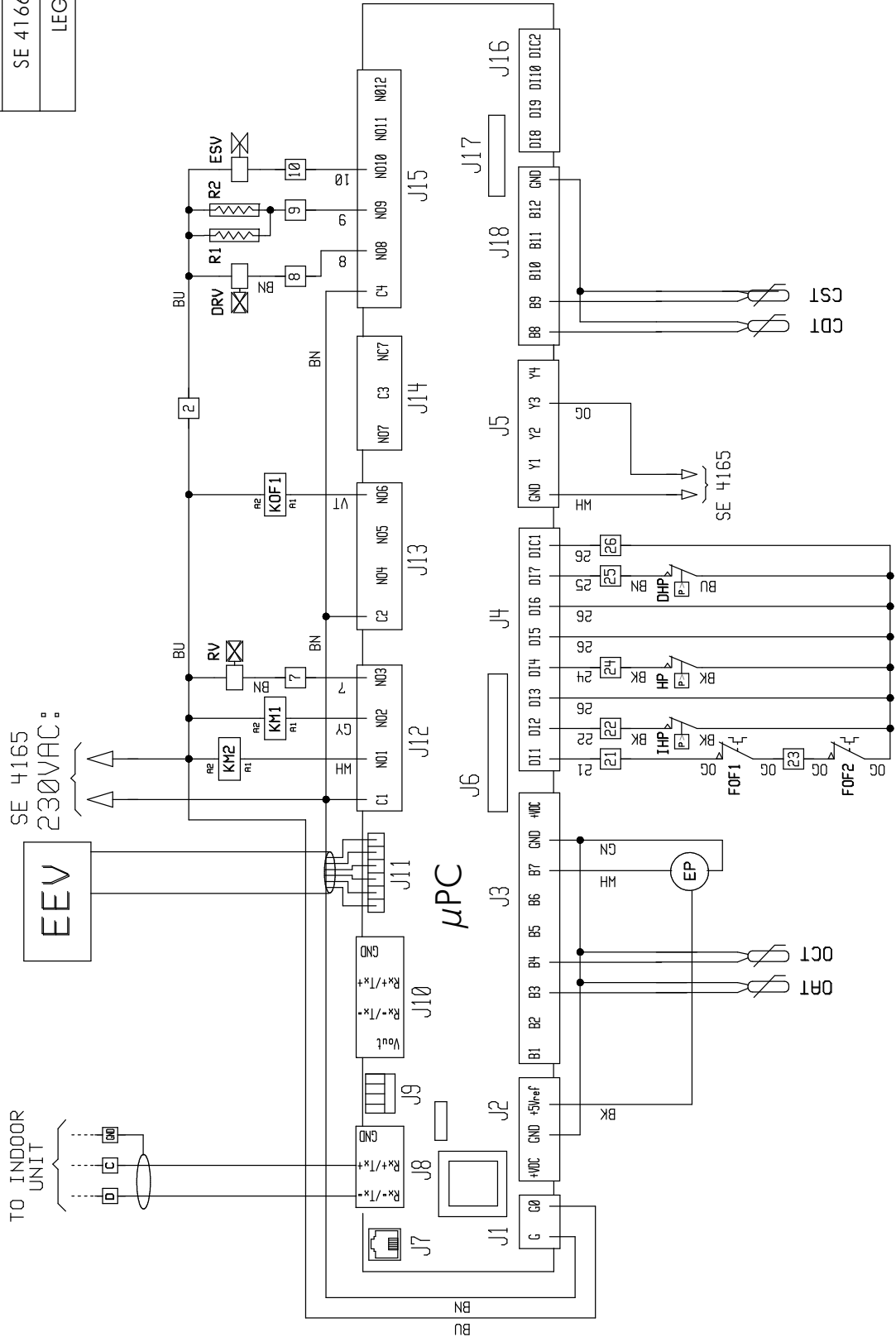

POWER WIRING DIAGRAM	
AQU@SCOP HT SPLIT (14-7) 230V OUTDOOR UNIT	
SE 4165	3991225
LEGEND N 791	

BK	BLACK
BN	BLUE
BU	BROWN
BYE	GREEN/YELLOW
GY	GREY
OG	ORANGE
RD	RED
VT	VIOLET
WH	WHITE

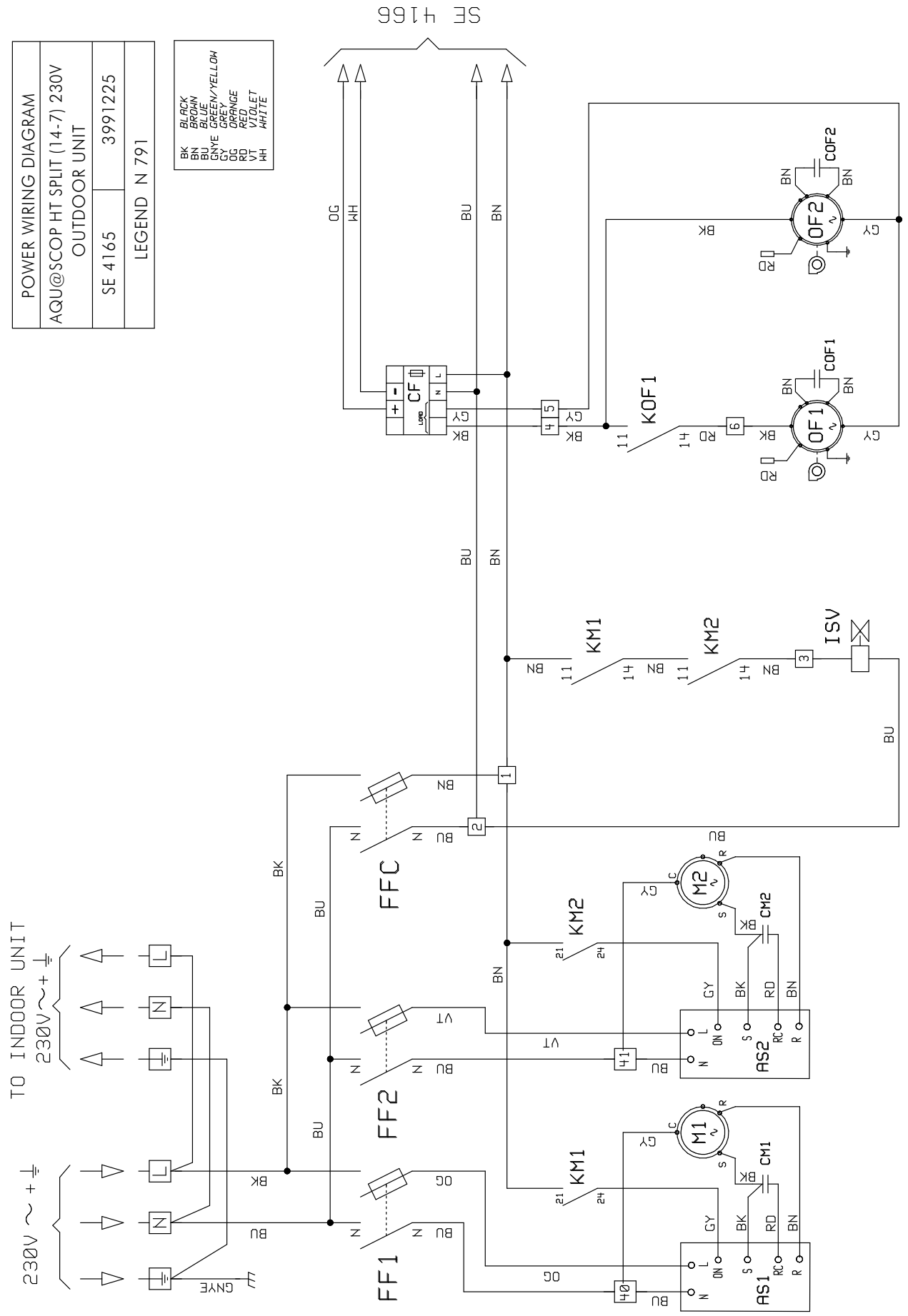

APPENDIX / ANNEXE / ANLAGE / ALLEGATO / ANEXO

AQU@SCOP HT SPLIT 12-6 3N~400V +/-10% 50HZ

CONTROL WIRING DIAGRAM	
AQU@SCOP HT SPLIT (12-6) 3N400V OUTDOOR UNIT	
SE 4168	3991228
LEGEND N 791	

BK	BLACK
BECHN	BROWN
BU	BLUE
GRN	GREEN
GY	GREY
OG	ORANGE
RD	RED
VT	VIOLET
WH	WHITE

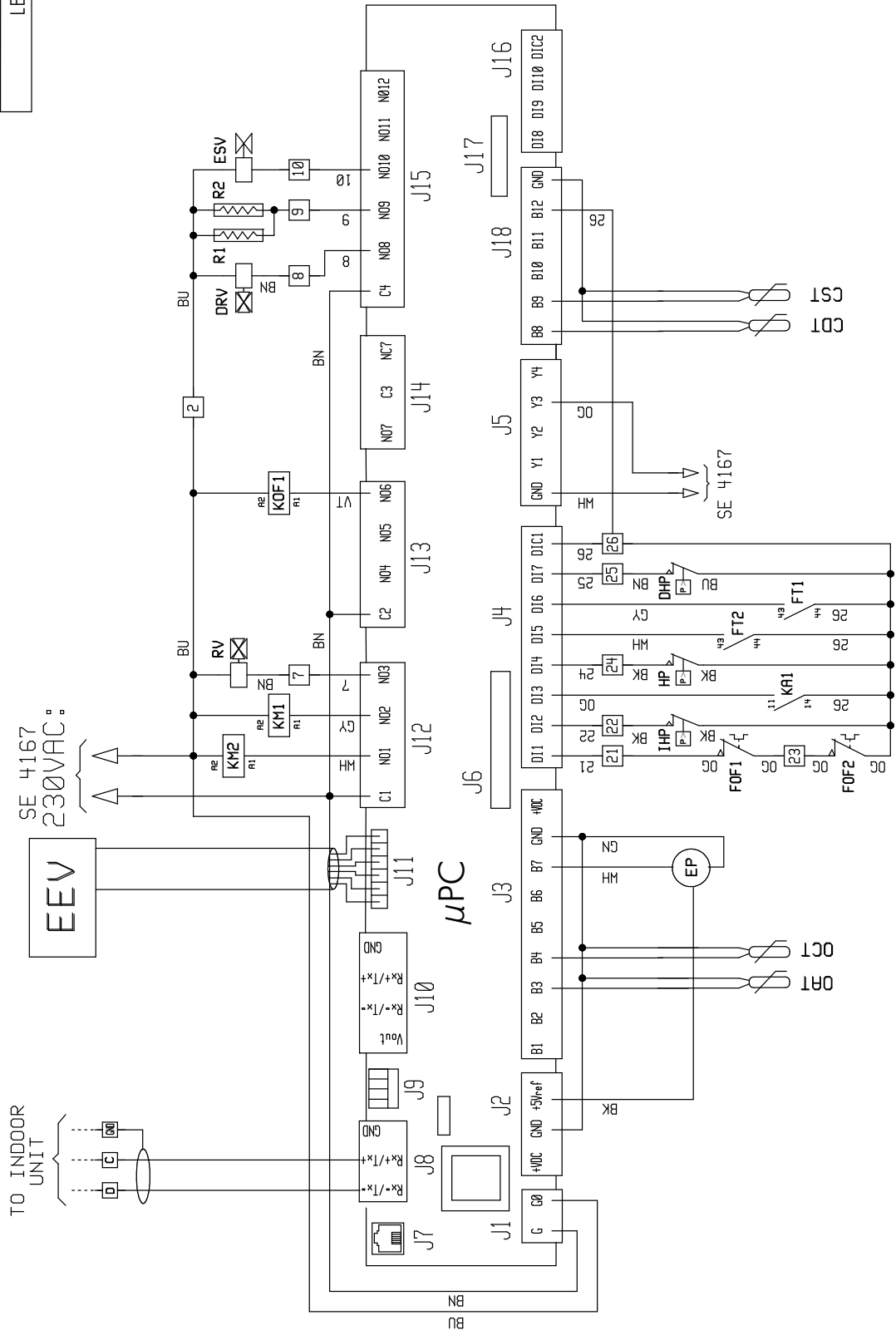

APPENDIX / ANNEXE / ANLAGE / ALLEGATO / ANEXO

AQU@SCOP HT SPLIT 14-7 3N~400V +/-10% 50HZ

CONTROL WIRING DIAGRAM	
AQU@SCOP HT SPLIT (14-7) 3N400V OUTDOOR UNIT	
SE 4169	3991229
LEGEND N 791	

BK	BLACK
BN	BROWN
BU	BLUE
GY	GREEN/YELLOW
GG	GREEN
OR	ORANGE
RD	RED
VT	VIOLET
MH	WHITE

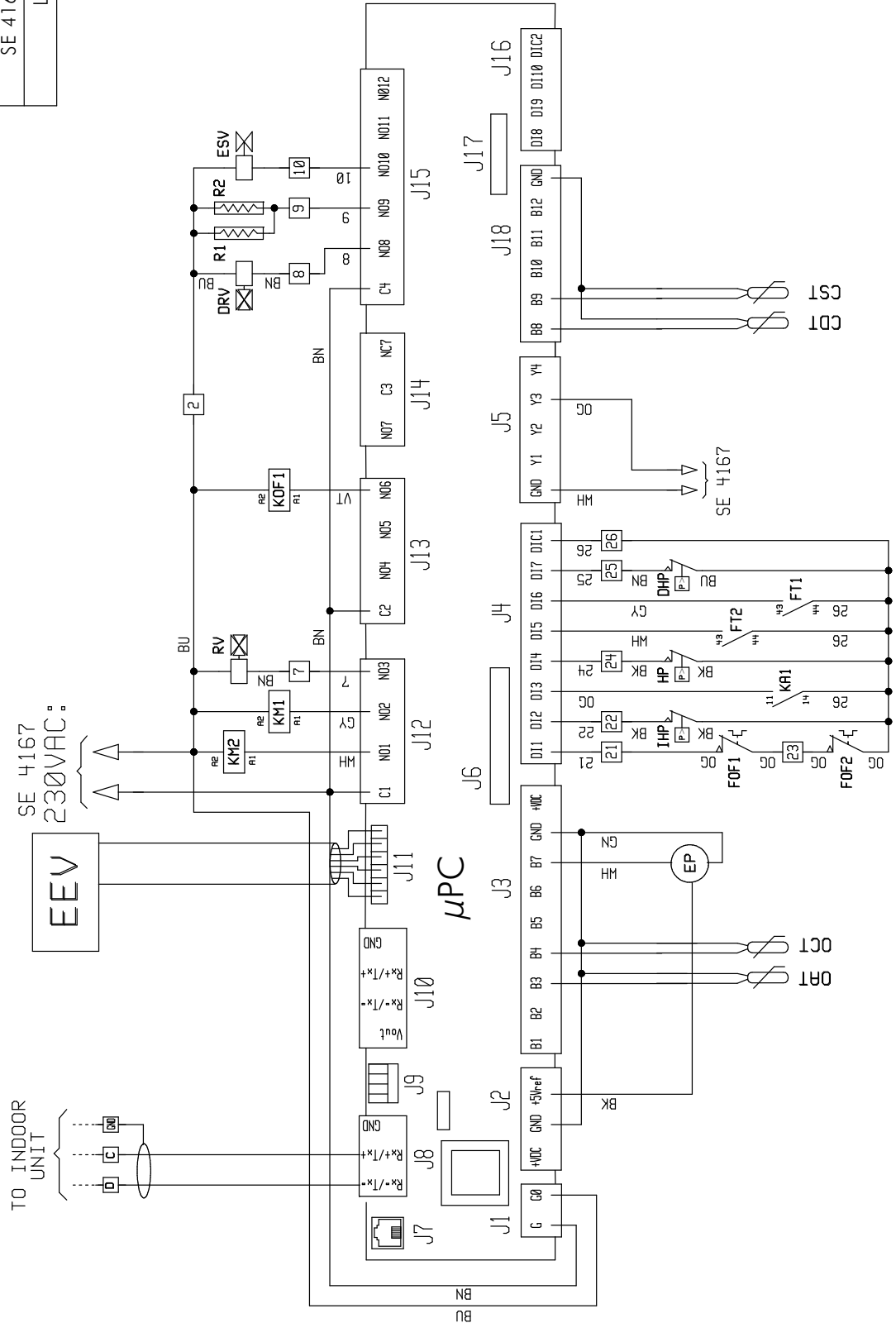

APPENDIX / ANNEXE / ANLAGE / ALLEGATO / ANEXO

AQU@SCOP HT SPLIT 12-6 / 14-7 3N~400V +/-10% 50HZ

POWER WIRING DIAGRAM	
AQU@SCOP HT SPLIT (12-6+14-7) 3N400V	
OUTDOOR UNIT	
SE 4167	3991227
LEGEND N 791	

BK	BLACK
BN	BROWN
BR	BROWN
BU	BLUE
BY	GREEN/YELLOW
GY	GREY
OR	ORANGE
OG	RED
RD	RED
VT	VIOLET
WH	WHITE

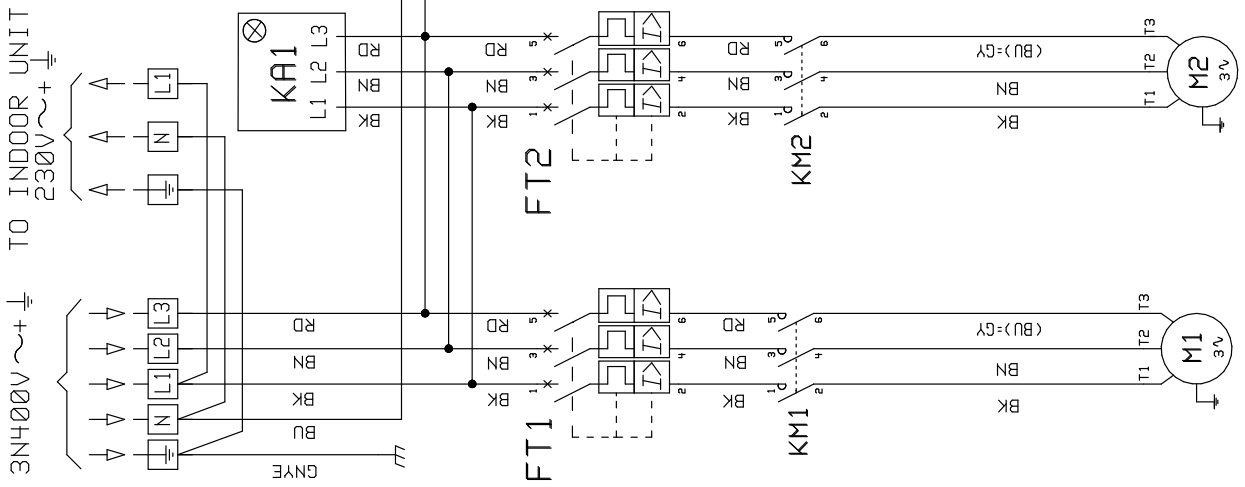
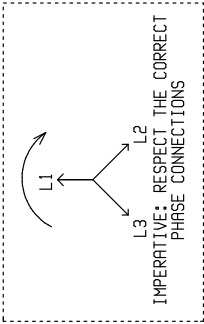

APPENDIX / ANNEXE / ANLAGE / ALLEGATO / ANEXO

AQU@SCOP HT SPLIT 18-9 3N~400V +/-10% 50HZ

CONTROL WIRING DIAGRAM	
AQU@SCOP HT SPLIT (18-9) 3N400V OUTDOOR UNIT	
SE 4171	3991231
LEGEND N 791	

BK	BLACK
BN	BROWN
BU	BLUE
CN	CYAN
GY	GREY
OG	ORANGE
RD	RED
VT	VIOLET
WH	WHITE

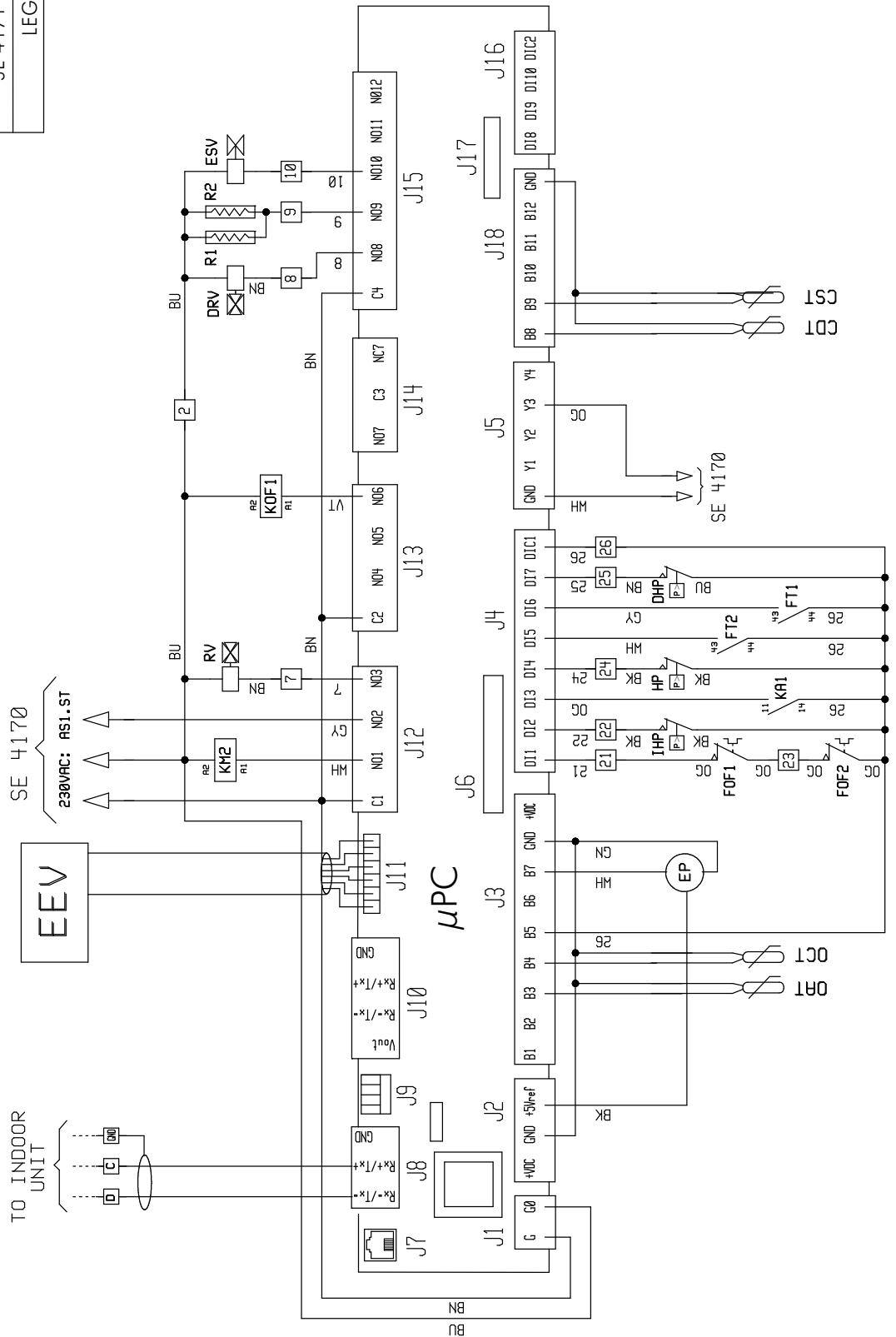

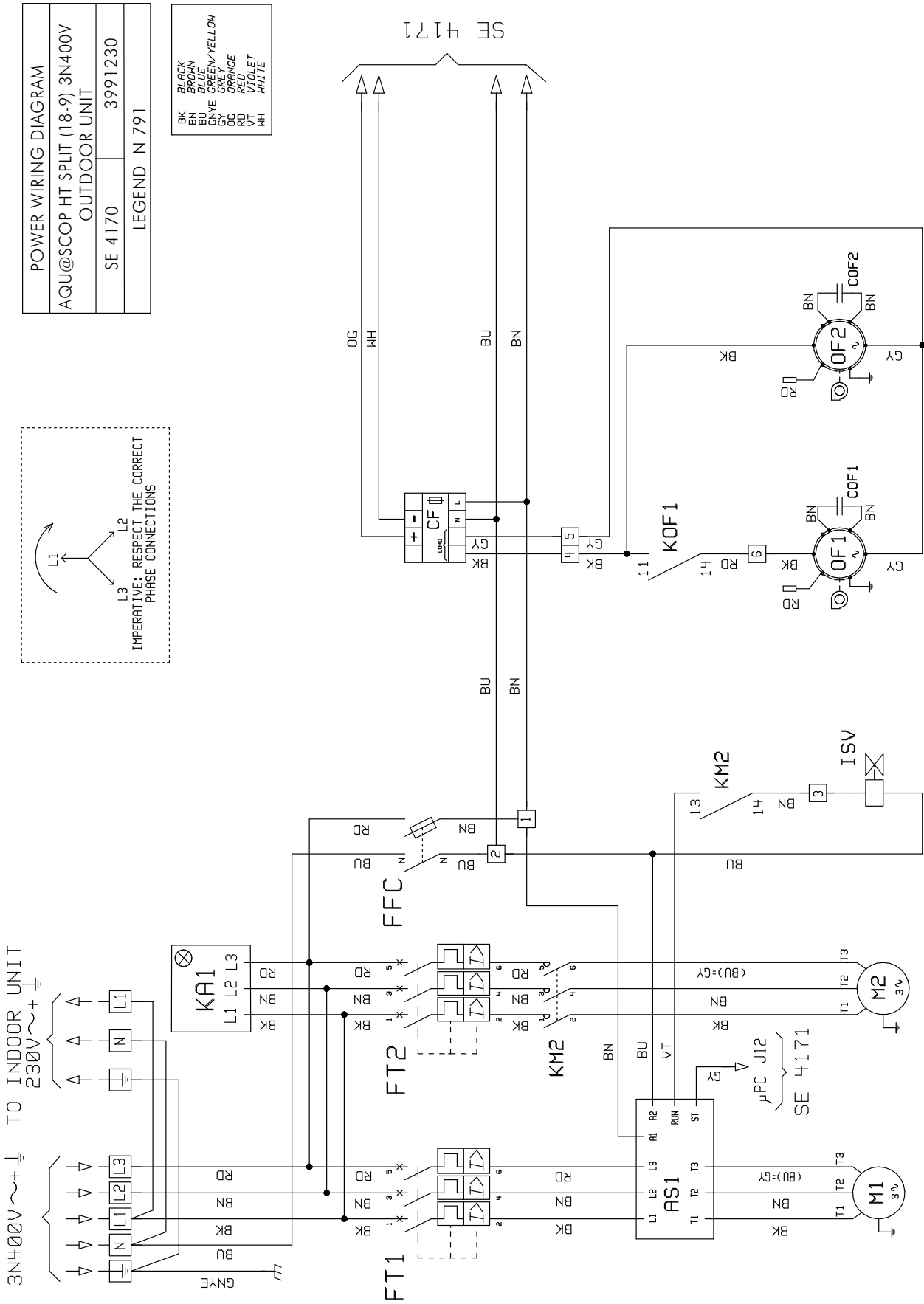

AQU@SCOP HT SPLIT INDOOR UNIT

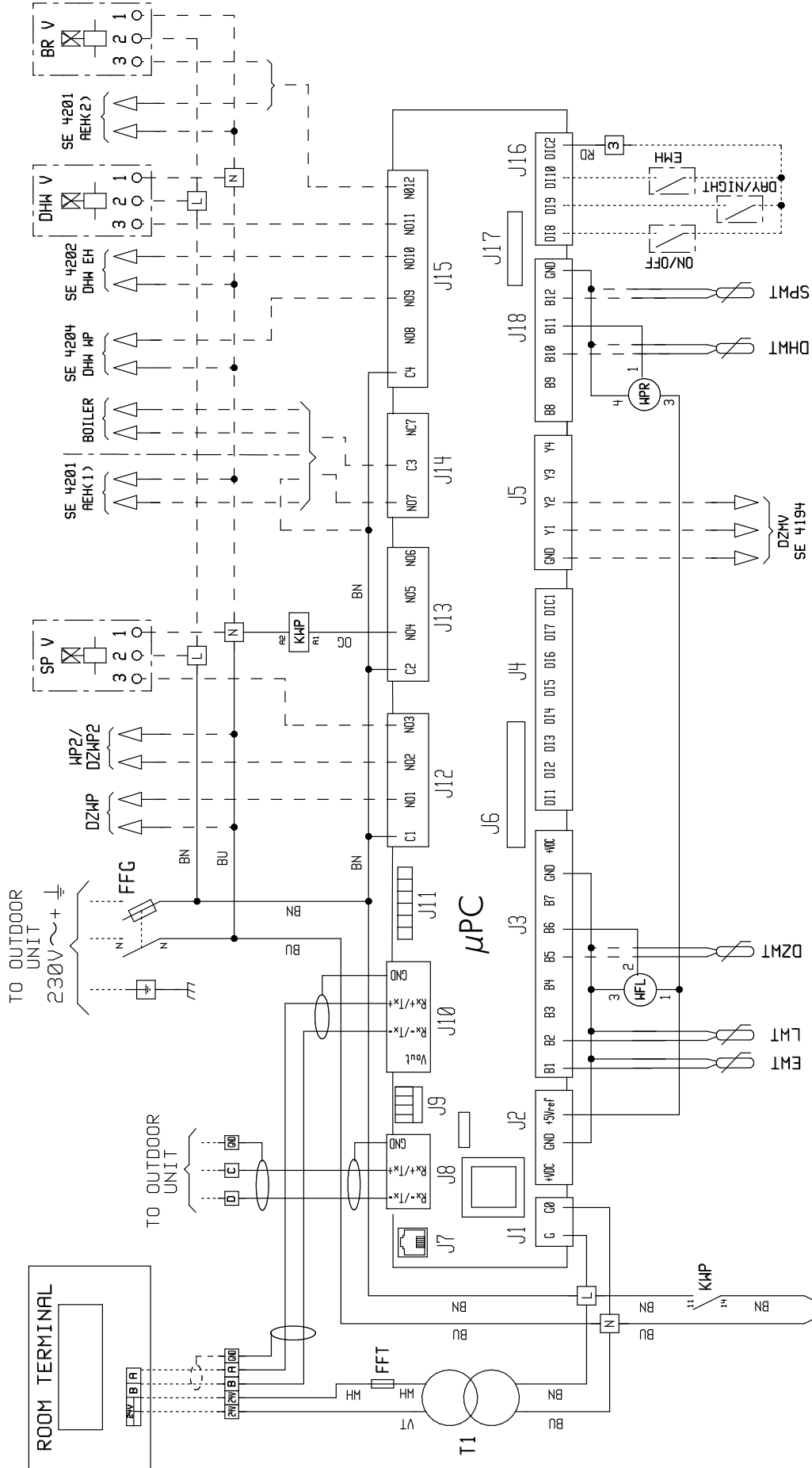

BK	BLACK
BN	BROWN
BU	BLUE
CNYE	GREEN/YELLOW
CY	CYAN
GR	GREEN
OR	ORANGE
RD	RED
VT	VIOLET
WH	WHITE

OPTION

 BRANCHEMENT
 CLIENT

WIRING DIAGRAM	
AQU@SCOP HT SPLIT INDOOR UNIT	
SE 4162 A	3991222
LEGEND N 791	

APPENDIX / ANNEXE / ANLAGE / ALLEGATO / ANEXO

DOMESTIC HOT WATER TANK
BALLON D'EAU CHAUDE SANITAIRE
BRAUCHWASSERVERSORGUNG
PALLA DI ACQUA CALDA SANITARIA
ACUMULADOR DE AGUA CALIENTE SANITARIA

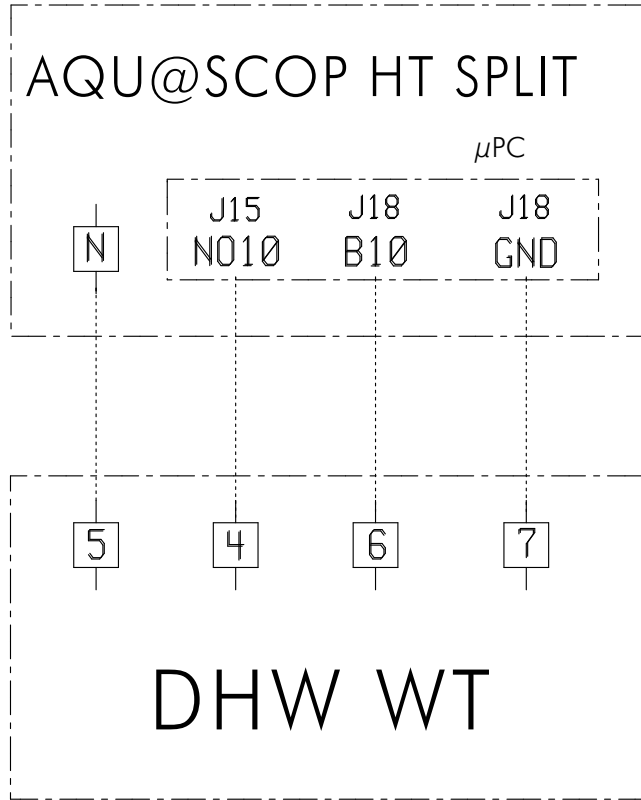

ADDITIONAL ELECTRIC HEATER
CHAUFFAGE ELECTRIQUE ADDITIONNEL
ZUSATZLICHE ELEKTROHEIZUNG
RESISTENZE ELETTRICHE ADDIZIONALE
CALEFACCION ELECTRTRICA ADICIONAL

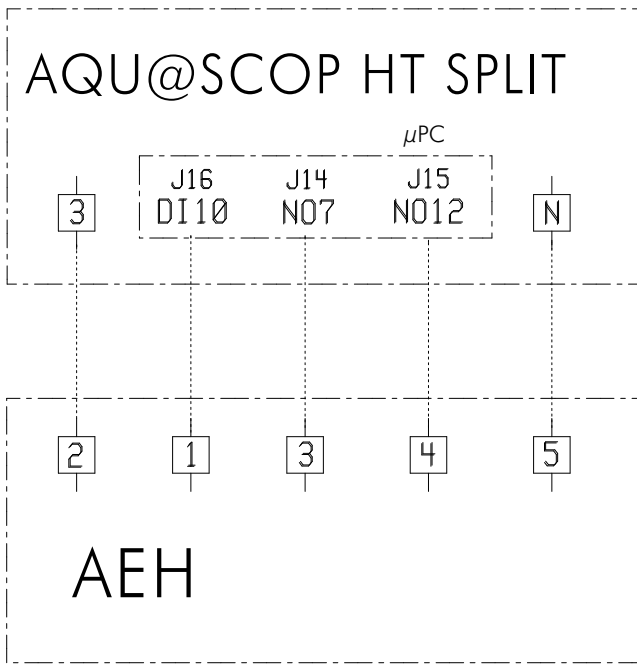

CONNECTION DIAGRAM
SE 4202 A

μPC	REGULATEUR DE L'AQU@SCOP HT SPLIT
DHW WT	BALLON D'EAU CHAUDE SANITAIRE
μPC	AQU@SCOP HT SPLIT CONTROLLER
DHW WT	DOMESTIC HOT WATER TANK
μPC	KONTROLLEUR DES AQU@SCOP HT SPLIT
DHW WT	BRAUCHWASSERVERSORGUNG
μPC	CONTROLLO ELETTRONICO DEL AQU@SCOP HT SPLIT
DHW WT	PALLA DI ACQUA CALDA SANITARIA
μPC	CONTROL DE LA AQU@SCOP HT SPLIT
DHW WT	ACUMULADOR DE AGUA CALIENTE SANITARIA

CONNECTION DIAGRAM
SE 4201

μPC	REGULATEUR DE L' AQU@SCOP HT SPLIT
AEH	CHAUFFAGE ELECTRIQUE ADDITIONNEL
μPC	AQU@SCOP HT SPLIT CONTROLLER
AEH	ADDITIONAL ELECTRIC HEATER
μPC	KONTROLLEUR DES AQU@SCOP HT SPLIT
AEH	ZUSATZLICHE ELEKTROHEIZUNG
μPC	CONTROLLO ELETTRONICO DEL AQU@SCOP HT SPLIT
AEH	RESISTENZE ELETTRICHE ADDIZIONALE
μPC	CONTROL DE LA AQU@SCOP HT SPLIT
AEH	CALEFACCION ELECTRTRICA ADICIONAL

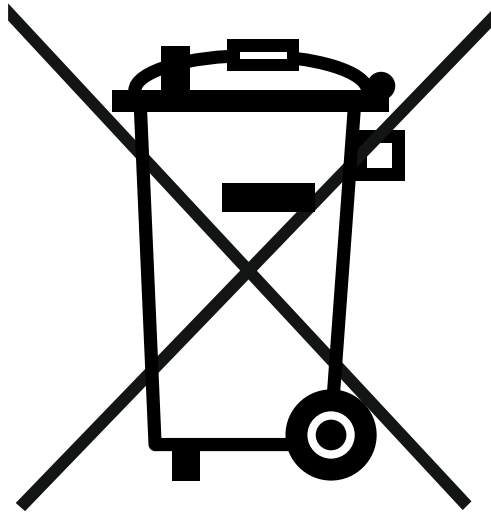

English

The meaning of the above logo representing a crossed-out wheeled bin is that this unit must not be disposed of as unsorted municipal waste but should be collected separately as WEEE (Waste Electrical and Electronic Equipment).

The presence of hazardous substances in electrical and electronic equipment or an improper use of such equipments or of parts thereof as well as the hazards of not separating WEEE from unsorted domestic waste, may affect the environment and human health.

As an End User, you are required to place WEEE in a collection separate from that for unsorted domestic waste. Please contact a point of sale or installer to find out the collection system available at your local community. You may return your old air conditioning unit for free to the point of sale or the installer when purchasing a new one.

As an End User, it is your role to contribute to the reuse, recycling and other forms of recovery of such wastes so as to reduce the disposal of waste. This will help preserve your environment.

Français

Le logo ci-dessus représentant une "poubelle barrée" signifie qu'il ne faut pas se débarrasser de cet appareil comme d'un déchet classique mais que celui-ci doit être collecté séparément en tant que DEEE (Déchet d'Équipement Électrique et Electronique).

La présence de substances dangereuses dans les équipements électriques et électroniques, l'utilisation inappropriée de tels équipements ou partie de tels équipements ainsi que le danger représentant la collecte non centralisée de matériels DEEE peuvent être préjudiciables à l'environnement et à la santé publique.

En tant qu'utilisateur final, il vous est demandé de collecter les DEEE séparément des déchets ordinaires. Vous êtes priés de prendre contact avec votre revendeur ou votre installateur pour qu'il vous indique le mode de collecte de votre commune. Lors du renouvellement de votre appareil, vous avez la possibilité de rendre votre ancien appareil gratuitement à votre installateur ou votre revendeur qui se chargera d'en assurer la collecte. En tant qu'utilisateur final, il est de votre devoir de participer à la réutilisation, au recyclage, et à toute autre forme de récupération de tels déchets afin d'en diminuer la quantité. Cela contribuera à la préservation de l'environnement.

Deutsch

Die Bedeutung des Logos mit der durchgestrichenen Mülltonne besteht darin, dass es sich bei diesem Gerät nicht um Hausmüll (Wertstoffmüll oder Restmüll) handelt.

Dieses Gerät ist nach der Elektro- und Elektronikgerätegesetz ElektroG (WEEE) zu sammeln und zu entsorgen.

Durch das Vorhandensein von gefährlichen Substanzen in elektrischen oder elektronischen Bauteilen kann die missbräuchliche Verwendung solcher Teile oder das Entsorgen solcher Geräte über den Hausmüll zu nicht unerhebliche Umwelt- und/ oder Gesundheitsschäden führen.

Sie als Endkunde sind angehalten, Geräte, welche unter die ElektroG (WEEE) fallen, separat vom Hausmüll zu entsorgen. Bitte informieren Sie den Händler, Installateur oder Ihre Stadt- oder Gemeindeverwaltung, um einen Entsorgungsbetrieb in Ihrer Nähe ausfindig zu machen. Eine Möglichkeit besteht darin, das Gerät kostenlos bei Ihrem Händler oder Installateur abzugeben, wenn Sie sich ein neues Gerät kaufen.

Als Endkunde beteiligen Sie sich so an der Wiederverwendung, R ü c k g e w i n n u n g o d e r Wiederverwertung von derartigen Rohstoffen. Sie helfen, Müll zu vermeiden und leisten so Ihren Beitrag zu einer sauberen Umwelt.

Italiano

Il significato del logo qui sopra rappresentato indica che il apparecchio non deve essere appattamato come rifiuto nella spazzatura indifferenziata, ma deve essere smaltito separatamente in base alle direttive WEEE (Waste Electrical and Electronic Equipment - rifiuti elettrici ed elettronici), in accordo con il decreto legislativo n.151/2005.

A causa della presenza di sostanze tossiche nella componentistica elettrica o elettronica, uno smaltimento di queste o di parti di esse nei rifiuti non riciclabili, può avere effetti nocivi sull'ambiente e sulla salute umana.

Il Cliente è tenuto a separare i prodotti o parte di essi etichettati in base alle normative WEEE dai rifiuti domestici solidi. Per ulteriori informazioni si contatti un punto vendita o un installatore per conoscere il punto di raccolta più vicino alla propria città. Il Cliente può smaltire gratuitamente il vecchio apparecchio presso il punto vendita o l'installatore contestualmente all'acquisto di un nuovo apparecchio.

Qualora il punto vendita o l'installatore non si prendano carico delle incombenze necessarie allo smaltimento del vecchio apparecchio secondo la normativa prevista, potranno essere soggetti ad un'ammenda compresa tra i 150 ed i 400 euro per ogni unità. E' compito del Cliente provvedere al riutilizzo, al riciclo e ad altre forme di riduzione degli sprechi in modo tale da ridurre la quantità di rifiuti da smaltire. Questa normativa viene introdotta a sostegno di politiche ambientali.

Il mancato rispetto della legislazione vigente prevede quattro sanzioni pecuniarie comprese tra 25,82 euro e 619.74 euro.

Español

El significado de este logo que representa un cubo de basura con ruedas tachado, es que esta unidad no debe ser desechada como residuo doméstico sin clasificar, sino que deberá ser recogida de forma separada como RAEE (residuos aparatos eléctricos y electrónicos). La presencia de sustancias peligrosas en los aparatos eléctricos y electrónicos o un uso impropio de tales aparatos o de partes de los mismos, así como los peligros de no separar RAEE de los residuos domésticos sin clasificar, puede afectar al medio ambiente y a la salud.

Como usuario final, se le requiere para que ponga los RAEE en una recogida distinta de los residuos domésticos sin clasificar. Por favor, contacte con un punto de venta o instalador para averiguar el sistema de recogida disponible en su comunidad. Puede devolver gratis su antigua unidad al punto de venta o instalador cuando compre una unidad.

Como usuario final, su papel es contribuir a la reutilización, reciclado y otras formas de recuperación de dichos residuos para reducir la eliminación de basura. Esto ayudará a mantener el medio ambiente.

EC Compliance declaration

Under our own responsibility, we declare that the product designated in this manual comply with the provisions of the EEC directives listed hereafter and with the national legislation into which these directives have been transposed.

Déclaration CE de conformité

Nous déclarons sous notre responsabilité que les produits désignés dans la présente notice sont conformes aux dispositions des directives CEE énoncées ci-après et aux législations nationales les transposant.

EG-Konformitätserklärung

Wir erklären in eigener Verantwortung, das die in der vorliegenden Beschreibung angegebenen Produkte den Bestimmungen der nachstehend erwähnten EG-Richtlinien und den nationalen Gesetzesvorschriften entsprechen, in denen diese Richtlinien umgesetzt sind.

Dichiarazione CE di conformità

Dichiariamo, assumendone la responsabilità, che i prodotti descritti nel presente manuale sono conformi alle disposizioni delle direttive CEE di cui sott e alle legislazioni nazionali che li recepiscono

Declaración CE de conformidad

Declaramos, bajo nuestra responsabilidad, que los productos designados en este manual son conformes a las disposiciones de las directivas CEE enunciadas a continuación, así como a las legislaciones nacionales que las contemplan.

Aqu@Scop HT SPLIT 12-6 / Aqu@Scop HT SPLIT 14-7 / Aqu@Scop HT SPLIT 18-9

MACHINERY DIRECTIVE 2006 / 42 / EEC
LOW VOLTAGE DIRECTIVE (DBT) 2006 / 95 / EEC
ELECTROMAGNETIC COMPATIBILITY DIRECTIVE 2004 / 108 / EEC
PRESSURISE EQUIPMENT DIRECTIVE (DESP) 97 / 23 / EEC
SUB-MODULE A CATEGORY I

DIRECTIVE MACHINES 2006 / 42 / C.E.E.
DIRECTIVE BASSE TENSION (DBT) 2006 / 95 / C.E.E.
DIRECTIVE COMPATIBILITE ELECTROMAGNETIQUE 2004 / 108 / C.E.E.
DIRECTIVE DES EQUIPEMENTS SOUS PRESSION (DESP) 97 / 23 / C.E.E.
SOUS-MODULE A CATEGORIE I

RICHTLINIE MASCHINEN 2006 / 42 / EG
RICHTLINIE NIEDERSPANNUNG (DBT) 2006 / 95 / EG
RICHTLINIE ELEKTROMAGNETISCHE VERTRÄGLICHKEIT 2004 / 108 / EG
RICHTLINIE FÜR AUSRÜSTUNGEN UNTER DRUCK (DESP) 97 / 23 / EG
UNTER MODUL A, KATEGORIE I

DIRETTIVA MACHINE 2006 / 42 / CEE
DIRETTIVA BASSA TENSIONE (DBT) 2006 / 95 / CEE
DIRETTIVA COMPATIBILITA ELETTROMAGNETICA 2004 / 108 / CEE
DIRETTIVA DEGLI IMPIANTI SOTTO PRESSIONE (DESP) 97 / 23 / CEE
SOTTOMODULO A, CATEGORIA I

DIRECTIVA MAQUIAS 2006 / 42 / CEE
DIRECTIVA BAJA TENSION (DBT) 2006 / 95 / CEE
DIRECTIVA COMPATIBILIDAD ELECTROMAGNETICA 2004 / 108 / CEE
DIRECTIVA DE LOS EQUIPOS A PRESION (DESP) 97 / 23 / CEE
BAJA MODULO A, CATEGORIA I

And that the following paragraphs of the harmonised standards have been applied.
Et que les paragraphes suivants les normes harmonisées ont été appliqués.
Und dass die folgenden Paragraphen der vereinheitlichten Normen Angewandt wurden.
E che sono stati applicati i seguenti paragrafi delle norme armonizzate.
Y que se han aplicado los siguientes apartados de las normas armonizadas.

EN 378-2:2002
EN 61000-6-1:2007
EN 61000-3-3:1995 + A1 2001 + A2 2005
EN 60 335-1

EN 61000-6-3:2007
EN 61000-3-2:2006
EN 60 335-2-21
EN 60 335-2-40

A Tillières sur Avre
27570 - FRANCE
Le: 11/01/2012
Sébastien Blard
Quality Manager
AIRWELL Industrie France

AIRWELL INDUSTRIE FRANCE

Route de Verneuil
27570 Tillières-sur-Avre
FRANCE

☎ : +33 (0)2 32 60 61 00

☎ : +33 (0)2 32 32 55 13



As part of our ongoing product improvement programme, our products are subject to change without prior notice. Non contractual photos.

Dans un souci d'amélioration constante, nos produits peuvent être modifiés sans préavis. Photos non contractuelles.

In dem Bemühen um ständige Verbesserung können unsere Erzeugnisse ohne vorherige Ankündigung geändert werden. Fotos nicht vertraglich bindend.

A causa della politica di continua miglioria posta in atto dal costruttore, questi prodotti sono soggetti a modifiche senza alcun obbligo di preavviso. Le foto pubblicate non danno luogo ad alcun vincolo contrattuale.

Con objeto de mejorar constantemente, nuestros productos pueden ser modificados sin previo aviso. Fotos no contractuales.

