



Aqu@Scop HT V2 **Aqu@Scop HT Split**

High Temperature Air-to-Water Heat Pumps
Models 12-6, 14-7 and 18-9



12.0 to 17.9 kW



AIRWELL
WESPER

Installation examples - Single zone system (radiators)

➤ *Aqu@Scop HT V2 + Domestic Hot Water Tank*

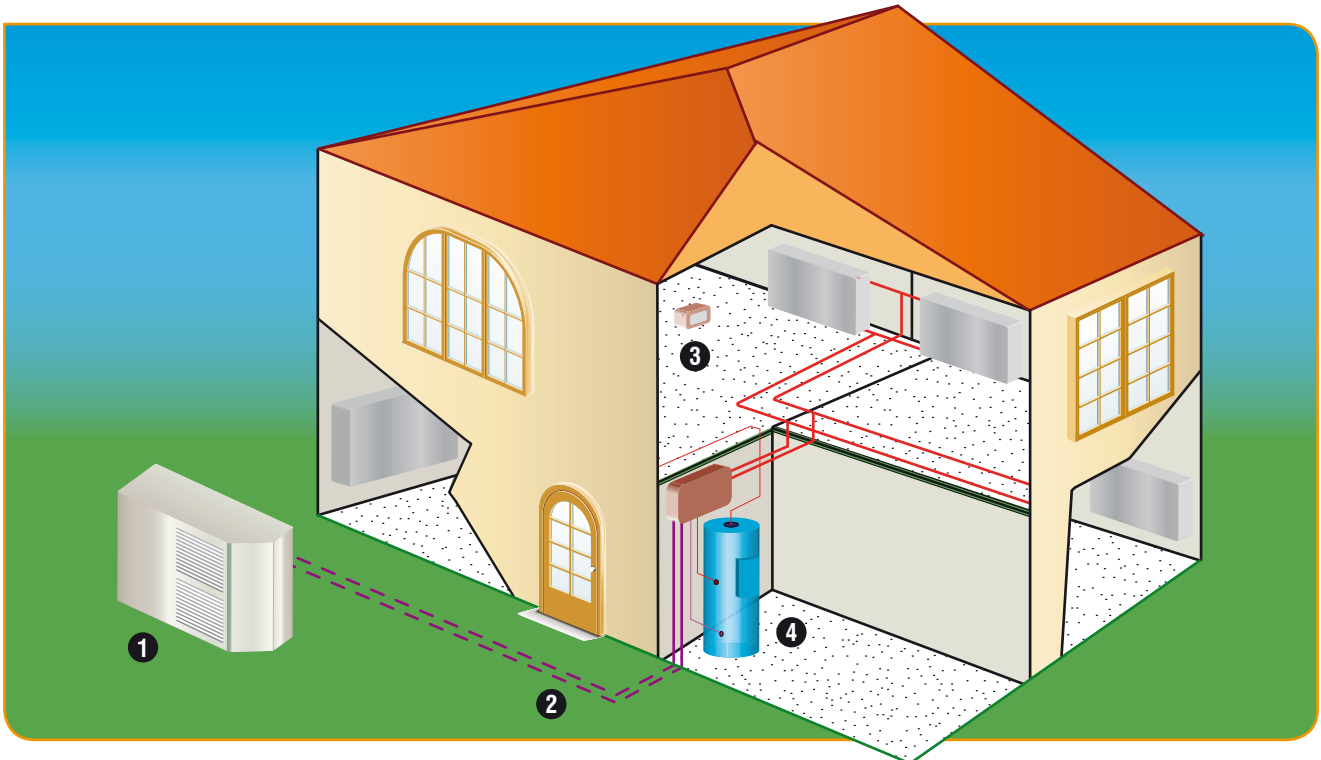

- ❶ Aqu@Scop HT V2
- ❷ Insulated underground hot water pipes
- ❸ Radiator system room thermostat
- ❹ Domestic Hot Water Tank

➤ *Aqu@Scop HT Split + Domestic Hot Water Tank*

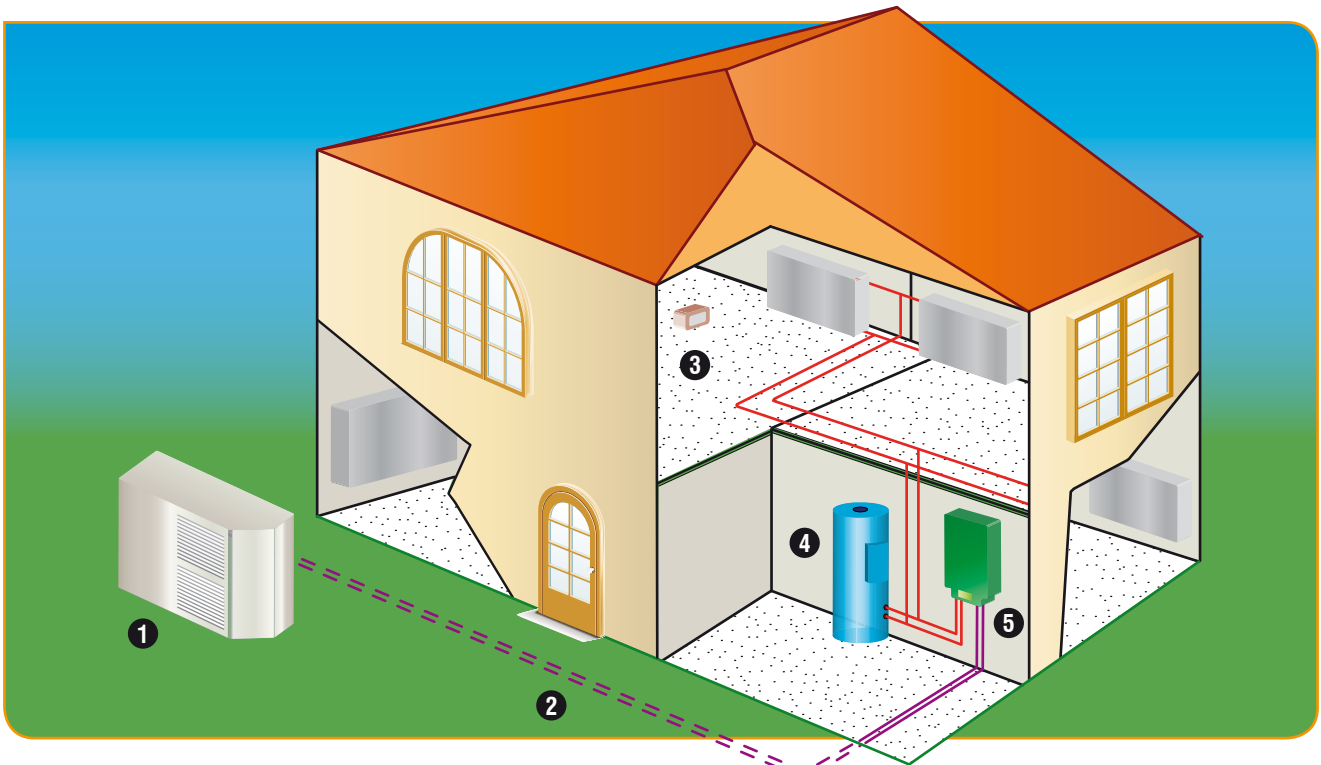

- ❶ Aqu@Scop HT Split outdoor unit
- ❷ Insulated underground refrigerant pipes
- ❸ Radiator system room thermostat
- ❹ Domestic Hot Water Tank
- ❺ Aqu@Scop HT Split indoor unit

Installation examples - Dual zone system (radiators + under floor heating)

➤ *Aqu@Scop HT V2 + Domestic Hot Water Tank*

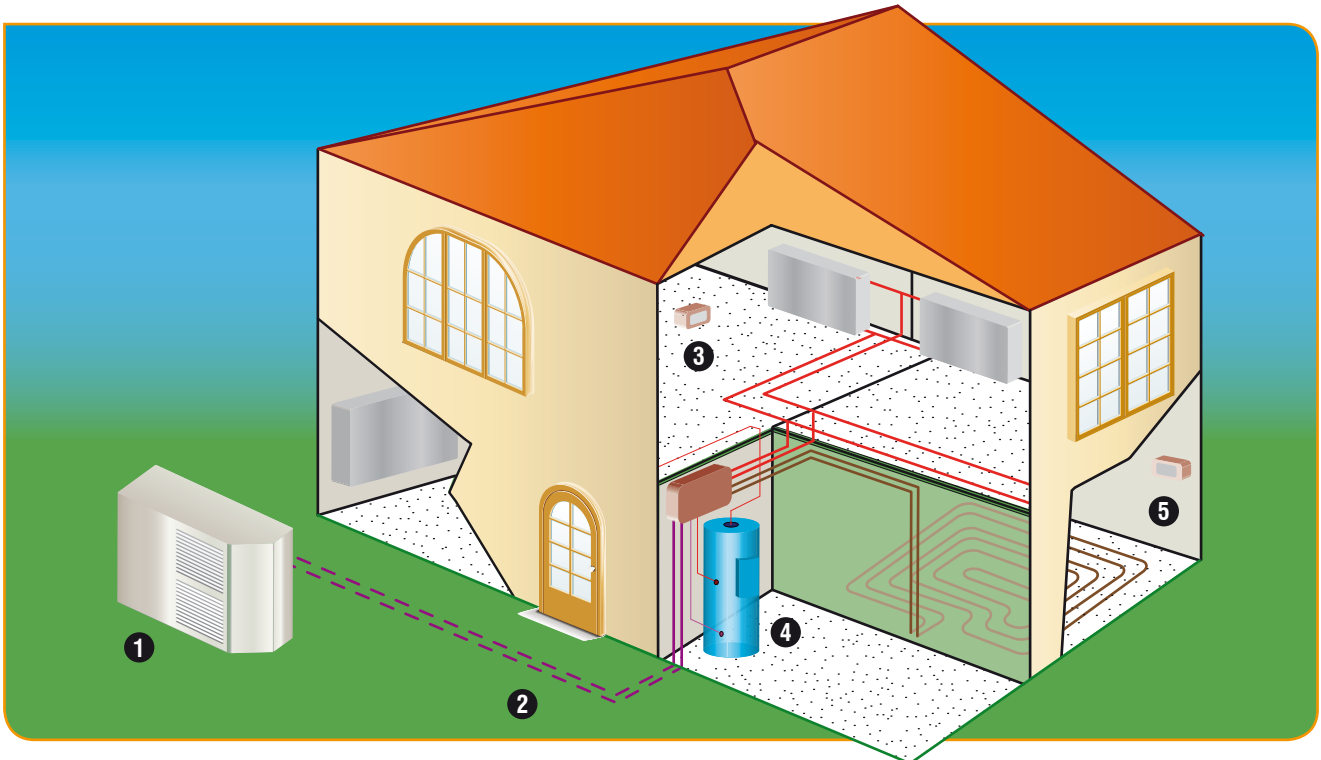

- ➊ Aqu@Scop HT V2
- ➋ Radiator system room thermostat
- ➌ Insulated underground hot water pipes
- ➍ Domestic Hot Water Tank
- ➎ Low temperature zone room thermostat (under-floor heating)

➤ *Aqu@Scop HT Split + Domestic Hot Water Tank*

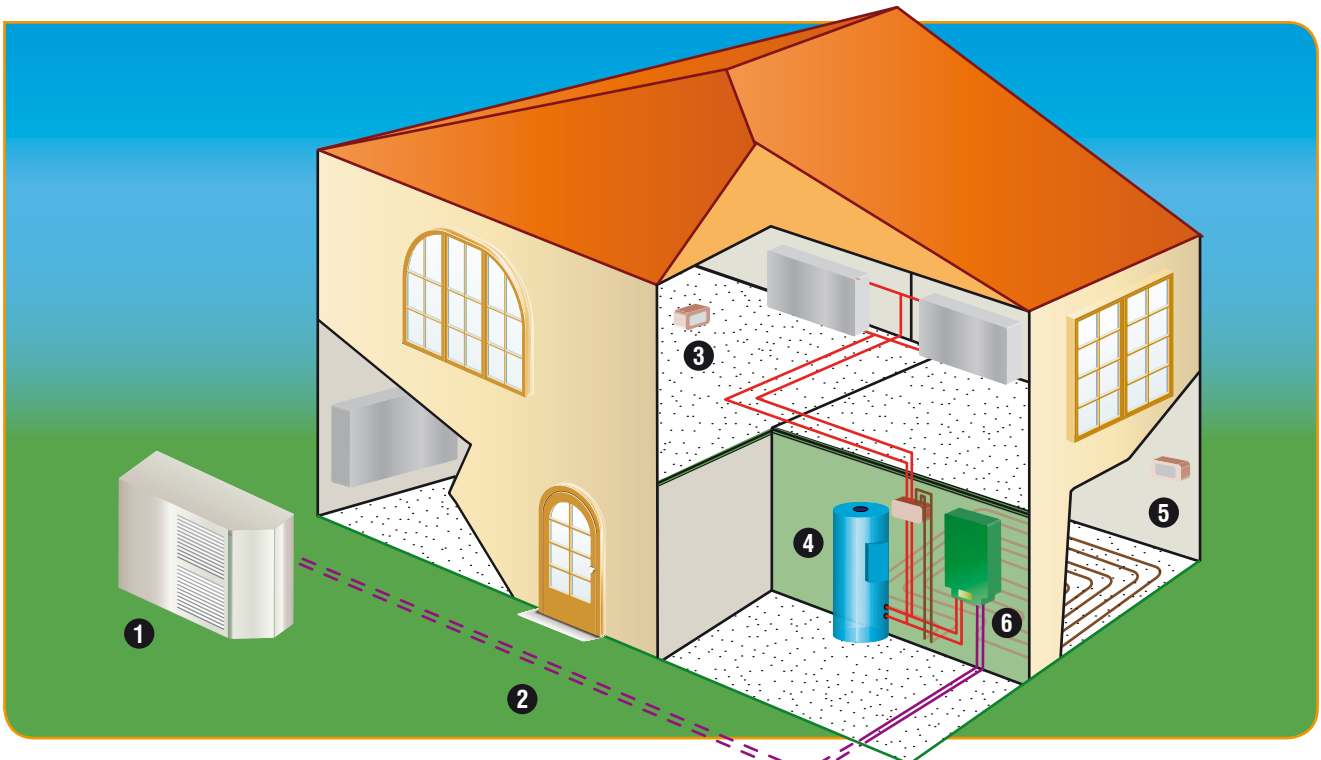

- ➊ Aqu@Scop HT Split outdoor unit
- ➋ Radiator system room thermostat
- ➌ Insulated underground refrigerant pipes
- ➍ Domestic Hot Water Tank
- ➎ Low temperature zone room thermostat (under-floor heating)
- ➏ Aqu@Scop HT Split indoor unit

Installation examples - Dual zone system (radiators + under floor heating)

➤ *Aqu@Scop HT V2 + Domestic Hot Water Tank + Boiler Relief*

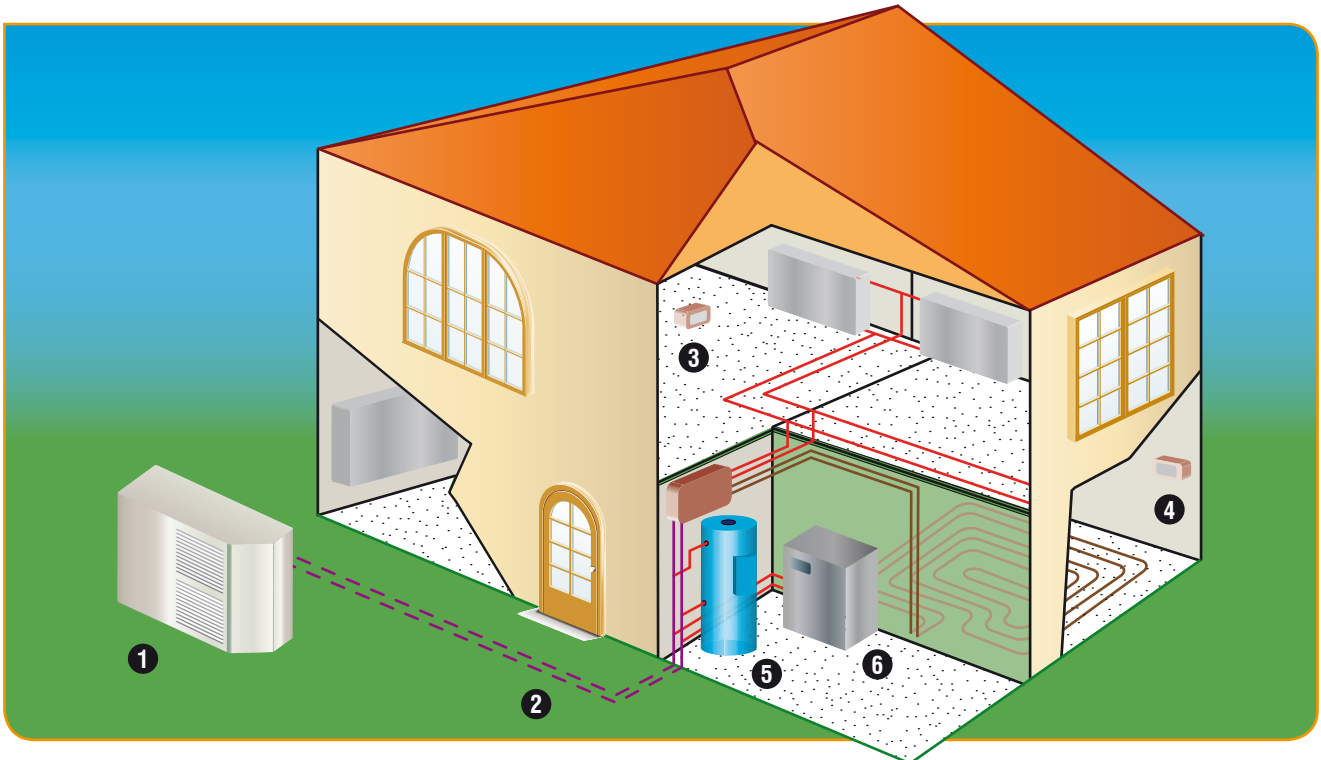

- ➊ Aqu@Scop HT V2
- ➋ Radiator system room thermostat
- ➌ Insulated underground hot water pipes
- ➍ Low temperature zone room thermostat (under-floor heating)
- ➎ Domestic Hot Water Tank
- ➏ Boiler

➤ *Aqu@Scop HT Split + Domestic Hot Water Tank + Boiler Relief*

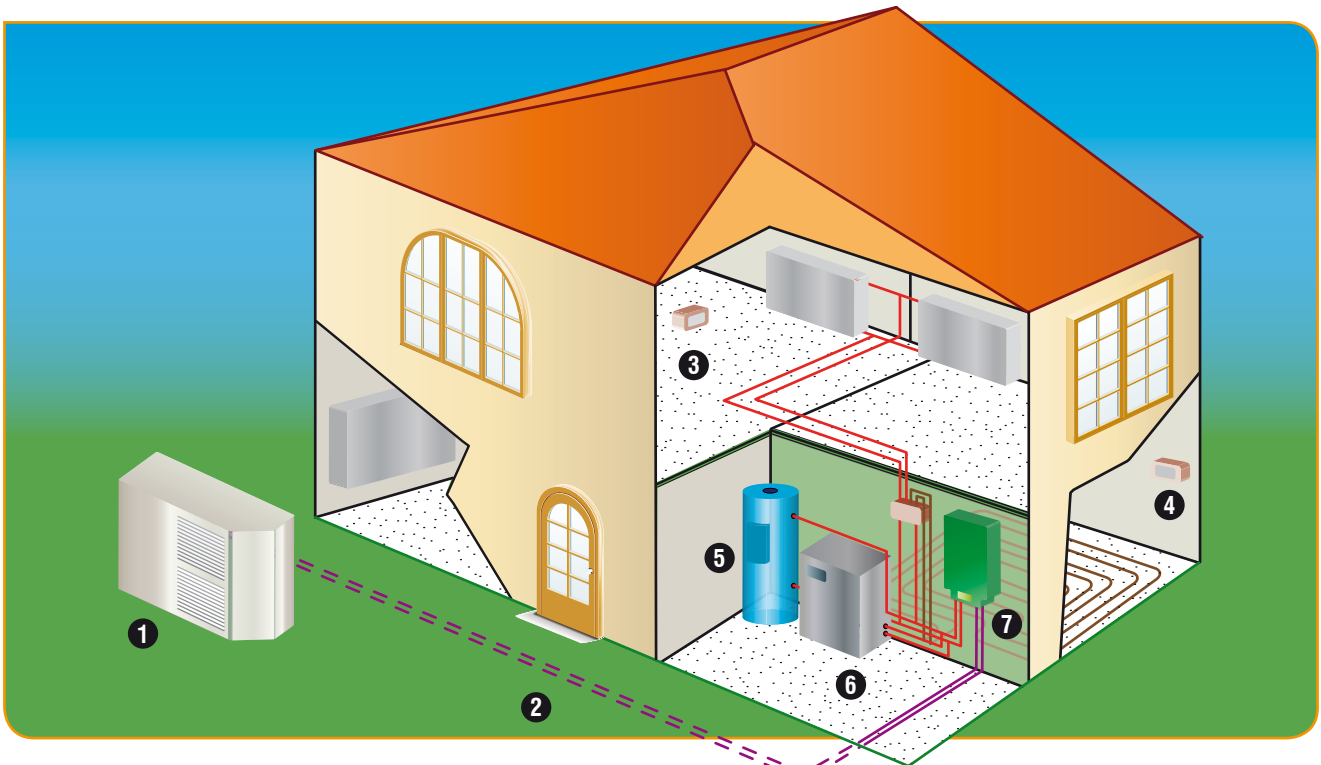

- ➊ Aqu@Scop HT Split outdoor unit
- ➋ Radiator system room thermostat
- ➌ Insulated underground refrigerant pipes
- ➍ Low temp. zone room thermostat (under-floor heating)
- ➎ DHW Tank
- ➏ Aqu@Scop HT Split indoor unit
- ➐ Boiler

General Characteristics

Introduction

The range of **Aqu@Scop HT V2 / Aqu@Scop HT Split** air/water high temperature heat pumps offers the special feature of producing hot water at 65 °C at outdoor temperatures down to -20 °C, while guaranteeing a high COP.

The new split system configuration **Aqu@Scop HT Split** consists of :

- a complete outdoor unit with refrigerant charge including all components and all functions tested on the monobloc version in order to guarantee the same high level of reliability while improving performance in icing conditions via a highly optimized evaporator.
- a hydraulic module including a high performance plate heat exchanger, multi-speed circulating pump, a real flowmeter (value displayed on the screen in l/h), an electronic water pressure sensor (available on the screen), a safety valve, an air vent, etc.. all in an elegant casing with smallest dimensions of the market.

For outdoor temperatures above +7° C, the **Aqu@Scop HT V2 / Aqu@Scop HT Split** supplies water at 55 °C with a single compressor.

Consequently, this **Aqu@Scop HT V2 / Aqu@Scop HT Split** unit is ideally suited to replace a traditional hot water boiler in producing Domestic Hot Water (DHW).

The patented technology uses two-stage compressors that provide :

➤ Higher COP :

In fact, in a two-stage system, each compressor operates at a low compression ratio, i.e. 3:1 compared with 12:1 for single-stage compressor systems.

This improves the compressors' service life and reduces electricity consumption.

➤ Same heating capacity maintained even with low outdoor temperatures :

As compressor efficiency is maintained, heat pump performance is hardly affected, even at low outdoor temperatures.

➤ Remarkable adaptability in terms of matching supplied capacity to heating requirements thanks to the possibility of using each compressor stage separately :

The **Aqu@Scop HT V2 / Aqu@Scop HT Split** controller chooses the optimum compressor staging configuration according to the demand for heating and the heat emitters' operating temperatures.

➤ Optimised Domestic Hot Water production :

Both for producing DHW and Heating, the controller determines the compressor staging best suited to the DHW tank coil's heat exchange capacity, while taking account of the outdoor temperature. At the end of the heating phase, the DHW temperature is very close to the condensing temperature without an unnecessary energy consumption.

Scope of application

The **Aqu@Scop HT V2 / Aqu@Scop HT Split** units are very well adapted for the under-floor heating applications, in new residence sector, with very high COP values especially at low outdoor temperature. They are also efficient for double zone applications with optimization of COP.

The **Aqu@Scop HT V2 / Aqu@Scop HT Split** units can also be used with **Boiler relief**.

Bodywork and structure

Steel bodywork coated with oven-baked epoxy paint coating.

The unit base is equipped with large openings under the coil for condensate or de-icing water drainage.

Removable panels on all sides allow access to the electrical box and to the refrigeration and hydraulic circuits. Closed bodywork protection index : IP 24.

Compressors

Maintenance-free Scroll type compressors produce a high efficiency with low sound levels.

The two-stage circuit equipped with 2 compressors with an unrivalled capacity ensures the best possible matching of supplied capacity to heating requirements.

Anti-vibration pads under the compressor prevent the transmission of any vibrations to the bodywork.

Water side exchangers

Brazed plate construction operating on a counter flow configuration in Winter mode to ensure excellent heating performance.

Air exchanger

Treated with a hydrophilic coating to assist condensed water drainage.

The exchanger is sized to avoid clogging, maintain its performance in sub-zero temperatures and cut the time and frequency of de-icing operations.

Fans

Reinforced polypropylene, low-speed helicoidal fans with optimised fan blade profiles to ensure efficient air flow at an extremely low sound level.

Fully-enclosed motor, maintenance-free bearings, automatic reset overheating protection device. The fan blades are shielded by plastic grilles for personal protection in accordance with health & safety standards.

Refrigerating circuit

The patented refrigerating circuit enables each compressor to be used independently or in two-stage mode.

The circuit, factory-filled and tested, includes a filter-dryer, a sight glass, a main electronic expansion valve and a thermostatic expansion valve for liquid injection, high and low pressure safety devices and all the equipment specific to two-stage technology.

Electrical box

The electrical box contains all the components for heat pump operation and notably the system's protection devices : compressor protection circuit breaker or fuse, protection fuse, standard start-up current limiter for single-phase units, phase sequence controller for three-phase units.

The microprocessor based controller integrated in the box controls all the heat pump's functions with the help of a room terminal and temperature sensors.

Safety functions controlled by the controller :

- ✔ High and low pressure safety, lack of water flow, lack of refrigerant charge, low evaporation pressure, high and low outlet water temperature limits, winter frost protection, compressor short cycling protection.
- ✔ Diagnosis of failures with history of 150 latest alarms (code, description, occurrence time and sensor values at the time of alarm).

Other functions managed by the controller :

- ✔ Water temperature control (inlet and outlet) depending on outdoor temperature and ambient temperature (water law).
- ✔ Choice of compressors for optimised efficiency.
- ✔ De-icing the outdoor exchanger in winter.
- ✔ Domestic Hot Water production management.
- ✔ 2-stage extra electric heating management.
- ✔ Management of boiler relief without additional kit (not compatible with extra electric heating).

General Characteristics (continued)

Standard equipment

The **Aqu@Scop HT V2 / Aqu@Scop HT Split** is supplied with the following standard equipment :

- Electrical box including electrical safety devices, circuit breakers, fuses.
- Electronic controller and its keypad screen.
- Main disconnect switch.
- Start-up current limiter (depending on models).
- Phase sequence controller (three phase models).
- Refrigeration circuit with its safety devices.
- Hydraulic kit comprising : 3 speed circulation pump, flow controller, automatic bleed, drain, pressure gauge, safety valve (3.5 bars).
- 4 pads for sound insulation under the casing.
- Exchanger protection grille.
- Water filter.
- 1 filter stop valve.

Options and accessories

Accessories available for fitting on site :

- Set of isolating valves with pressure tap.
- Set of 2 water flexible hoses (1 meter long).

Control

The water law parameters are programmed in the controller at the factory. It is possible to adapt them more precisely to the specific features of the home when the **Aqu@Scop HT V2 / Aqu@Scop HT Split** is being installed :

- Base outdoor temperature at the site of the home.
- Home heat losses compared against the base temperature for an ambient temperature of 20 °C.
- Inlet water temperature for the corresponding heat emitters.

The indoor terminal controls the ambient temperature. The water law can be altered depending on the desired comfort temperature and the variance between that and the actual measured temperature.

Functions accessible via the indoor terminal:

- Clock settings (times and day).
- Ambient temperature set point.
- Unoccupied period management.
- Comfort / forced economy modes.

- Hydraulic connection kit.
- Sludge trap (decantation filter).
- Domestic hot water tank (300 liters).
- Domestic hot water plate heat exchanger kits for :
 - wall mounted electrical tank (bottom domestic hot water outlet)
 - ground mounted electrical tank (top domestic hot water outlet)
- Directional valve to be associated with :
 - domestic hot water function
 - Boiler relief function
 - swimming pool function (with temperature sensor kit)
- Buffer tank (140 liters).
- Antivibration mounts.
- In line electric heater 6 kW.
- Dual zone management kit for under floor heating/radiators (modulating valve + electrical box management + temperature sensor)
- Dual zone management kit for existing valve (electrical box management + temperature sensor)
- Wired programmable room terminal (recommended for optimum operation).
- Wireless programmable room terminal (recommended for optimum operation).

- Freezing protection mode.
- Unit fault display in the form of error codes.

All the parameters needed to manage DHW production are accessible on the control display located inside the machine. Several DHW production modes are available :

- **Comfort mode** : Priority given to DHW production without any time or electricity tariff constraints.
- **Economy mode** : DHW is only produced during off-peak periods or in accordance with times programmed in the controller.
- **Immediate running** : The machine keypad can be used to force DHW production. At the end of the cycle the system reverts automatically to normal running.

The Legionnaires' disease protection function is included in the standard control system.

Operating Diagram - Two-stage Cycle with Economiser and Partial Injection

Aqu@Scop HT V2

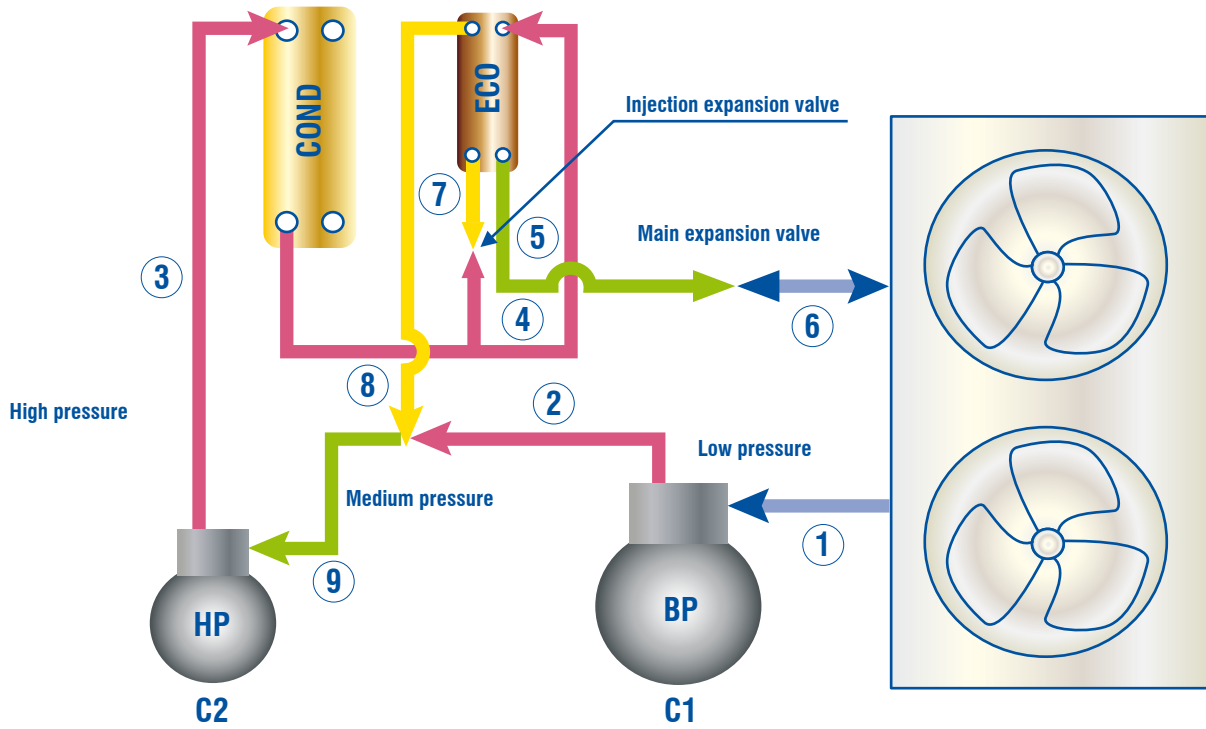

COND : Condenser
 ECO : Economiser
 LP : Low pressure
 HP : High pressure

Aqu@Scop HT Split

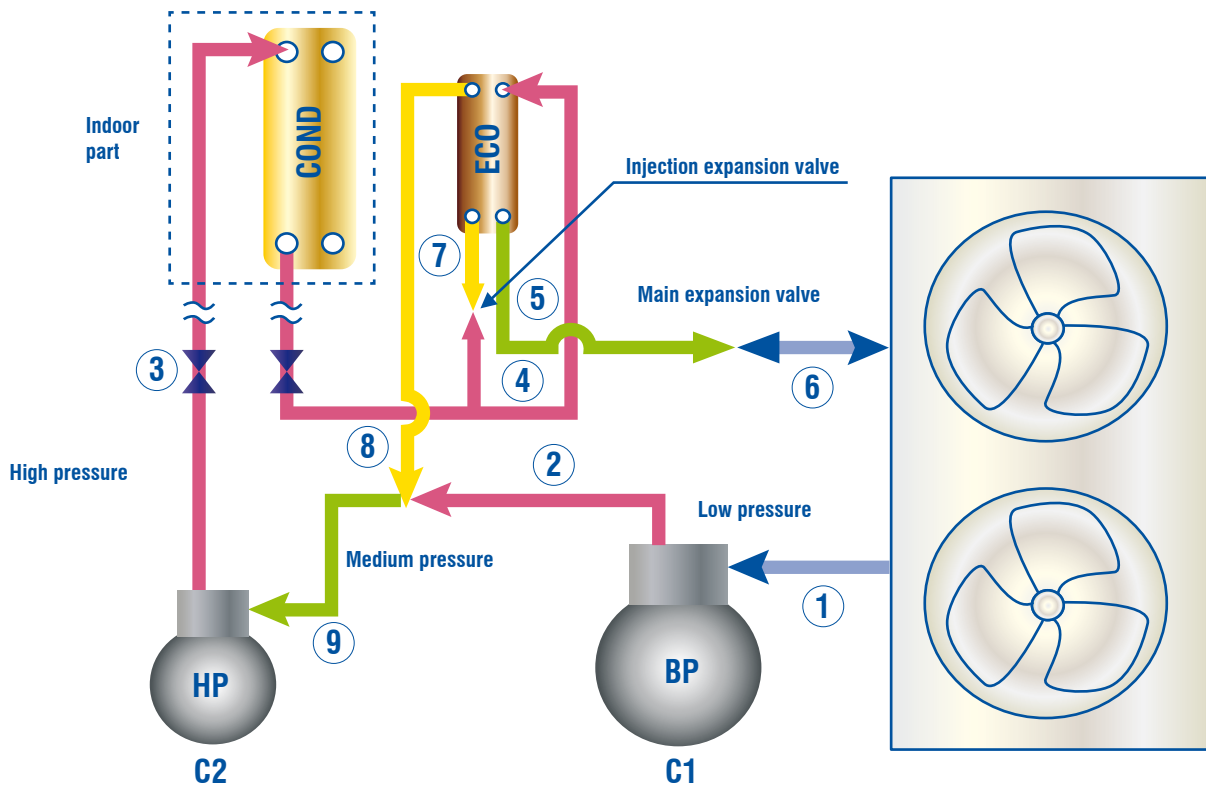

Principle of Operation

Operating cycle

The Aqu@Scop HT V2 / Aqu@Scop HT Split operates on a two-stage compression cycle.

It uses two compressors :

- the larger **(C1)** for the Low Pressure **(LP)** stage.
- the smaller **(C2)** for the High Pressure **(HP)** stage.

The economiser (refer to above diagram) located at the condenser outlet, receives some of the HP liquid **(point 4)** which, after expansion **(point 7)**, cools the main liquid circuit and generates cooled gas that is mixed with the gas coming from the LP compressor **(point 8)**.

This economiser has two functions :

- Sub-cooling the liquid to increase the evaporator's and therefore the heat pump performance, both in heating mode and in domestic hot water production mode.
- Generating cooled gas to cool the HP compressor suction side.

When the LP or the HP compressor operates on its own, its cycle is identical to that of a traditional single compressor cycle.

Compressor operation

The action on the two 4-way cycle inversion valves V1 and V2 creates the following operating modes :

- C2 (HP) compressor on its own.
- C1 (LP) compressor on its own,
- C1 and C2 compressors together.
- De-icing with the C1 compressor on its own.

When heating needs are low and the water outlet temperature required is below 55 °C, the small compressor C2 operates on its own. The machine runs in normal mode but at a reduced capacity within an outdoor temperature range of +20 °C to 0 °C by producing hot water at temperatures between +35 °C and +55 °C.

Within these same operating limits (outdoor temperatures and hot water temperatures), the larger compressor C1 operates instead of the smaller one when the heating needs are greater.

When the outdoor conditions are between +7 °C and -20 °C, the heat pump switches to high capacity mode with both compressors operating in series to produce hot water at temperatures between +50 °C and +65 °C.

Refrigerant Pippings and Additional Charges - Aqu@Scop HT Split

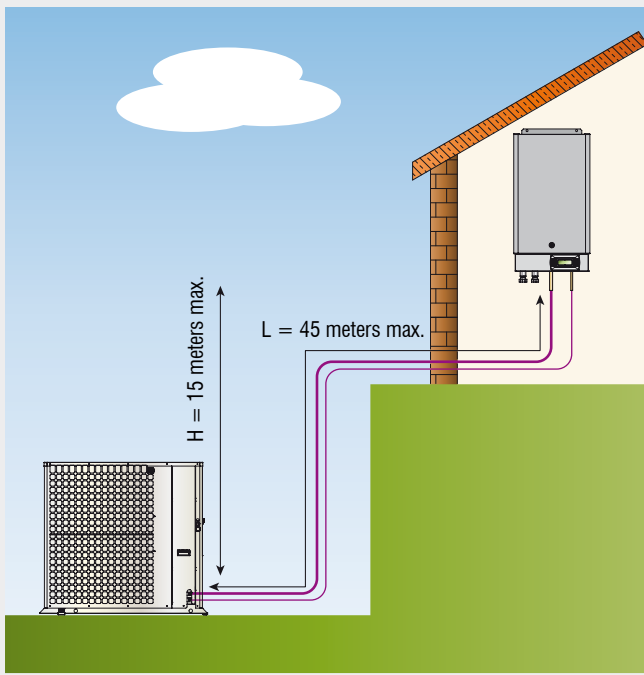
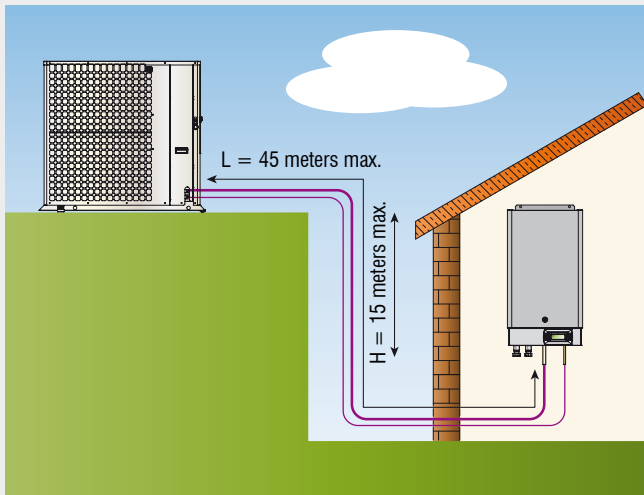
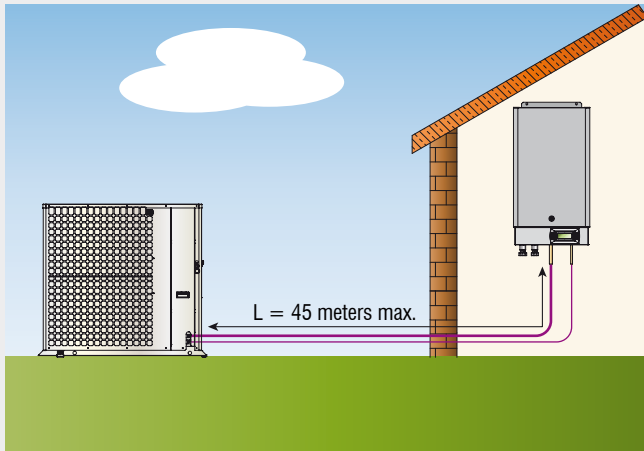

Length (meter)	Ø gas line (inch)	Ø liquid line (inch)	Additional charge (g)
20	5/8"	3/8"	0
21			57
22			114
23			171
24			228
25			285
26	3/4"	1/2"	1792
27			1904
28			2016
29			2128
30			2240
31			2352
32			2464
33			2576
34			2688
35			2800
36			2912
37			3024
38			3136
39			3248
40			3360
41			3472
42			3584
43			3696
44			3808
45	3920		

General Hydraulic Layout for a Type 1 (*) Installation - Aqu@Scop HT V2

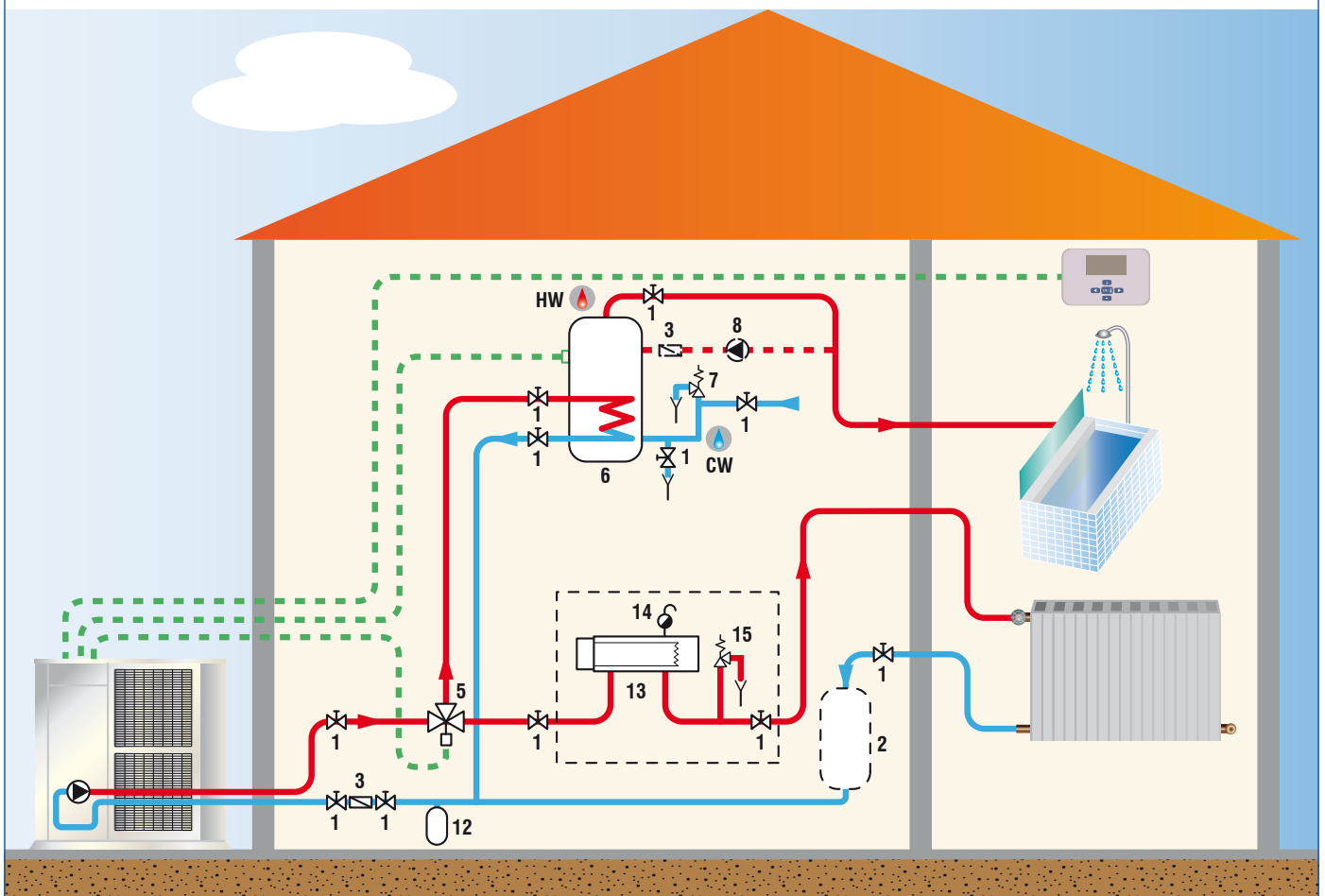

1	Stop valve	12	Expansion tank
2	Buffer tank (optional)	13	In-line heater
3	Filter or sludge trap	14	Bleed
5	3-way valve - Domestic hot water	15	Safety valve
6	Domestic hot water tank	HW : Hot Water	
7	Safety devices	CW : Cold Water	
8	Recycling circulating pump (optional)	*	Installation components not supplied

Layout 1 : Application without control, room by room

This layout is recommended when the Aqu@Scop HT V2 water flow is continuous and close to the nominal value (no radiator thermostatic valves). The buffer tank (2) provides extra circulating water volume to maintain the minimum volume.

General Hydraulic Layout for a Type 1 (*) Installation - Aqu@Scop HT Split

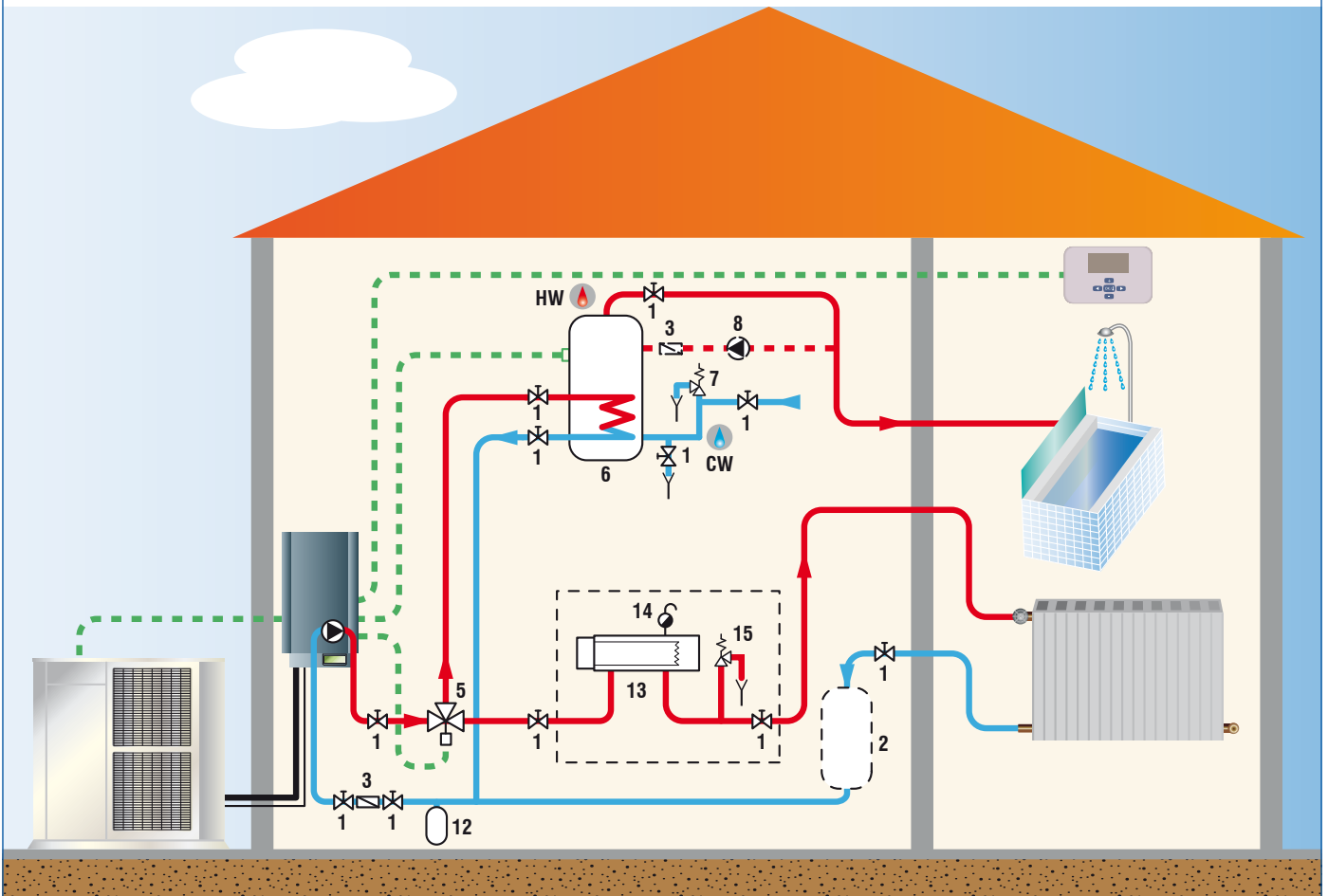

1	Stop valve	12	Expansion tank
2	Buffer tank (optional)	13	In-line heater
3	Filter or sludge trap	14	Bleed
5	3-way valve - Domestic hot water	15	Safety valve
6	Domestic hot water tank	HW	Hot Water
7	Safety devices	CW	Cold Water
8	Recycling circulating pump (optional)	*	Installation components not supplied

Layout 1 : Application without control, room by room

This layout is recommended when the Aqu@Scop HT Split water flow is continuous and close to the nominal value (no radiator thermostatic valves). The buffer tank (2) provides extra circulating water volume to maintain the minimum volume.

General Hydraulic Layout for a Type 2 (*) Installation - Aqu@Scop HT V2

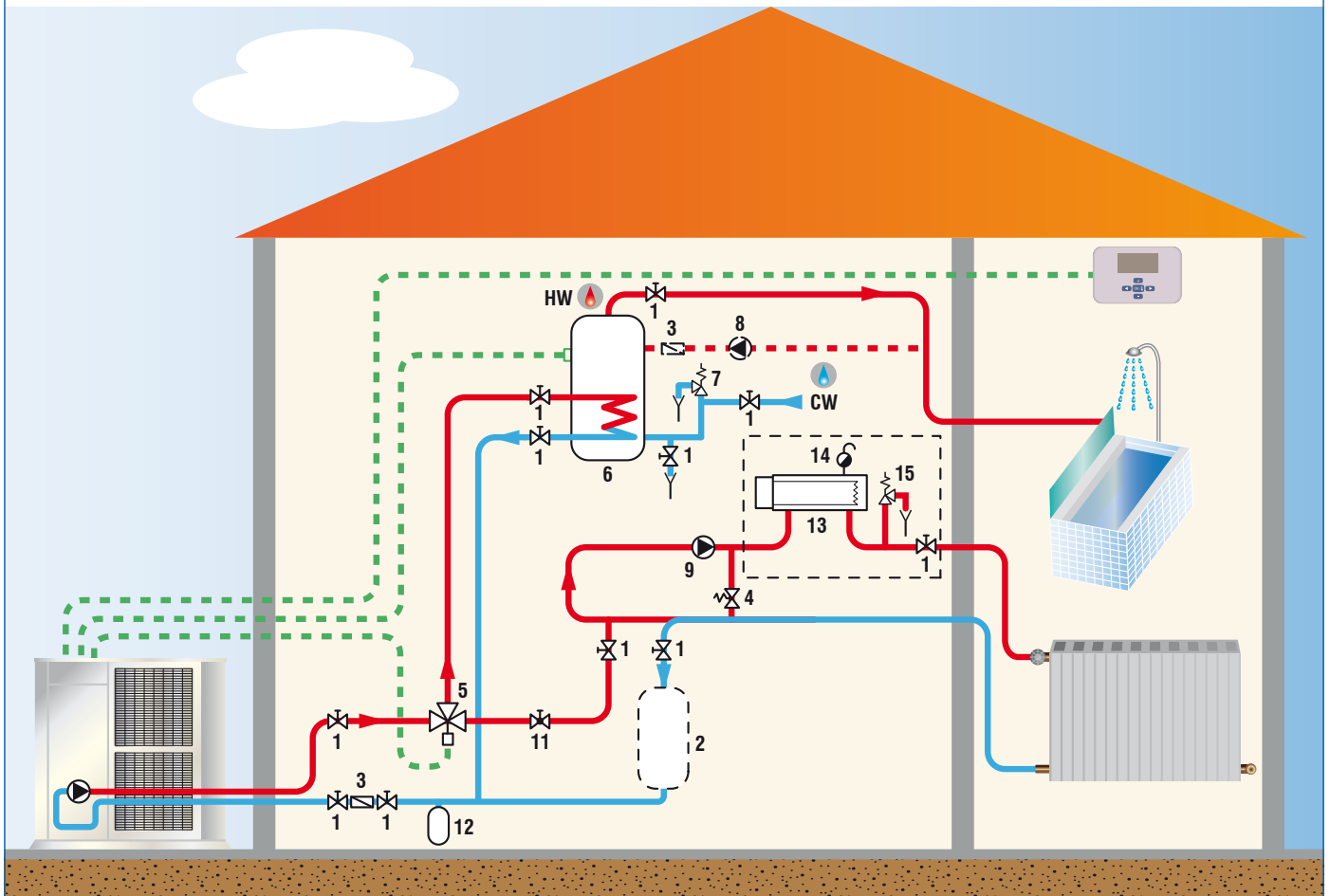

1	Stop valve	11	Flow regulating valve
2	Buffer tank (optional)	12	Expansion tank
3	Filter or sludge trap	13	In-line heater
4	Relief valve	14	Bleed
5	3-way valve - Domestic hot water	15	Safety valve
6	Domestic hot water tank	HW : Hot Water	
7	Safety devices	CW : Cold Water	
8	Recycling circulating pump (optional)	*	Installation components not supplied
9	Circulation pump		

Layout 2 : Application with control, room by room

This layout is recommended for heating installations with wide operating water flow variations (radiator thermostatic valves present in the system). We strongly recommend including the buffer tank (2) as it guarantees that the heating loop capacity is higher than the minimum volume when the maximum number of thermostatic valves are closed.

The flow adjustment valve (11) is used to balance the flow in heating mode and domestic hot water mode to always ensure optimum Aqu@Scop HT V2 operation.

General Hydraulic Layout for a Type 2 (*) Installation - Aqu@Scop HT Split

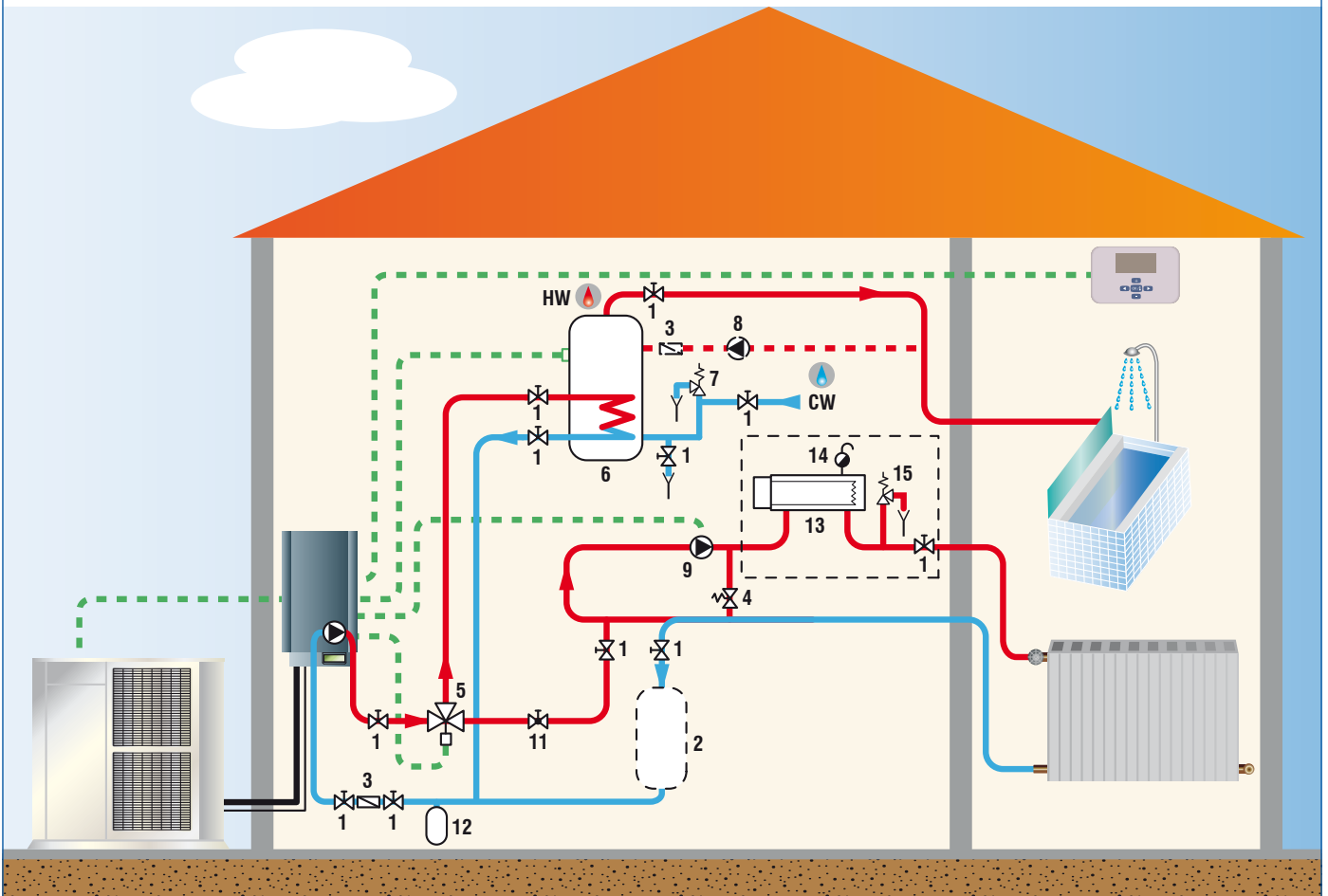

1	Stop valve	11	Flow regulating valve
2	Buffer tank (optional)	12	Expansion tank
3	Filter or sludge trap	13	In-line heater
4	Relief valve	14	Bleed
5	3-way valve - Domestic hot water	15	Safety valve
6	Domestic hot water tank	HW	Hot Water
7	Safety devices	CW	Cold Water
8	Recycling circulating pump (optional)	*	Installation components not supplied
9	Circulation pump		

Layout 2 : Application with control, room by room

This layout is recommended for heating installations with wide operating water flow variations (radiator thermostatic valves present in the system). We strongly recommend including the buffer tank (2) as it guarantees that the heating loop capacity is higher than the minimum volume when the maximum number of thermostatic valves are closed.

The flow adjustment valve (11) is used to balance the flow in heating mode and domestic hot water mode to always ensure optimum Aqu@Scop HT Split operation.

General Hydraulic Layout for a Type 3 (*) Installation - Aqu@Scop HT V2

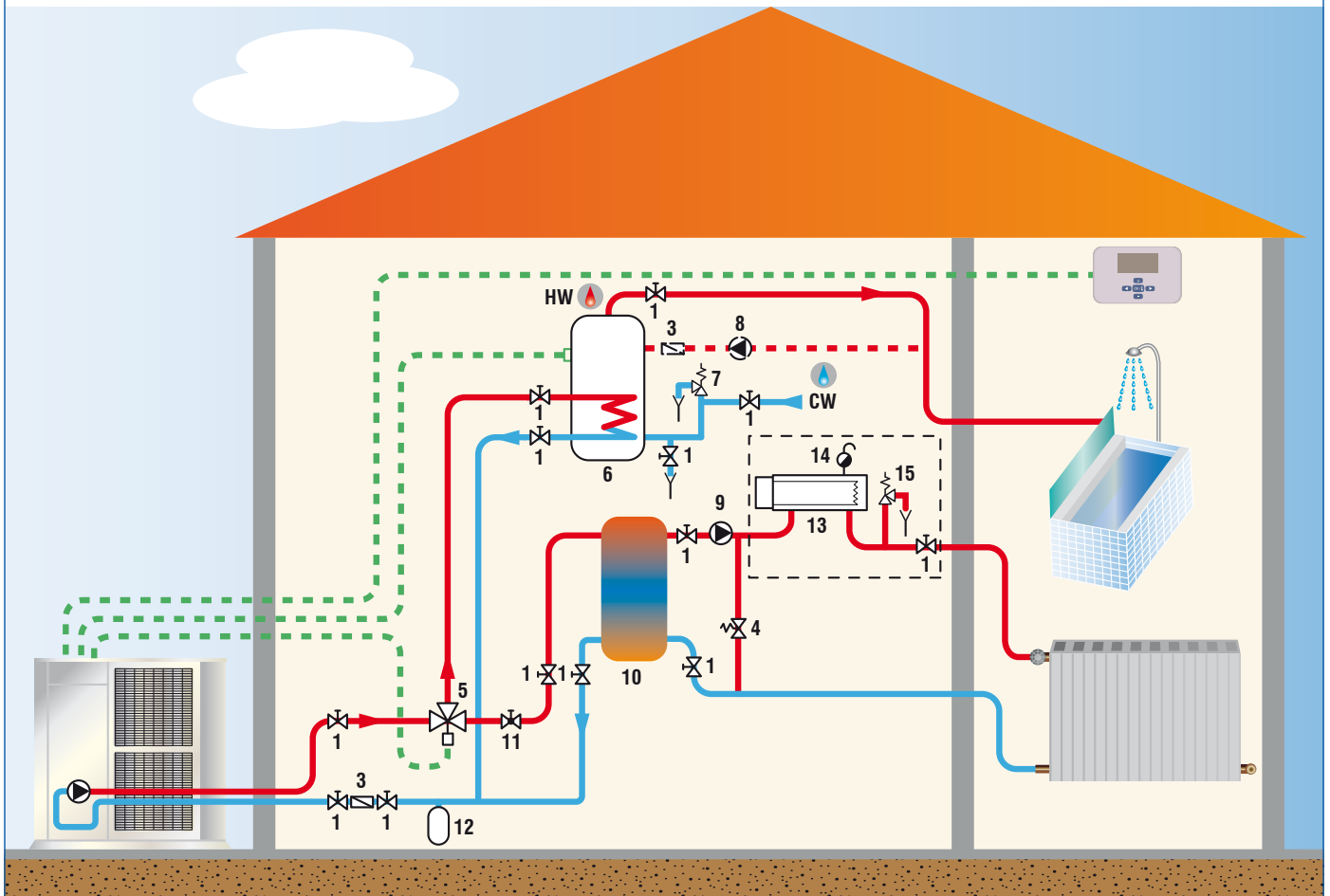

1	Stop valve	11	Flow regulating valve
3	Filter or sludge trap	12	Expansion tank
4	Relief valve	13	In-line heater
5	3-way valve - Domestic hot water	14	Bleed
6	Domestic hot water tank	15	Safety valve
7	Safety devices	HW	Hot Water
8	Recycling circulating pump (optional)	CW	Cold Water
9	Circulation pump	*	Installation components not supplied
10	Mixing tank		

Layout 3 : Application with control, room by room

This layout is also recommended for heating installations with wide operating water flow variations (radiator thermostatic valves present in the system). Minimum system volume is guaranteed by a mixing tank (10). Take care when calculating the volume of water in the installation and only take account of 50% of the mixing tank's volume.

Example : For a useful volume of 100 litres the actual mixing tank volume will be 200 litres.

The flow adjustment valve (11) is used to balance the flow in heating mode and domestic hot water mode to always ensure optimum Aqu@Scop HT V2 operation.

General Hydraulic Layout for a Type 3 (*) Installation - Aqu@Scop HT Split

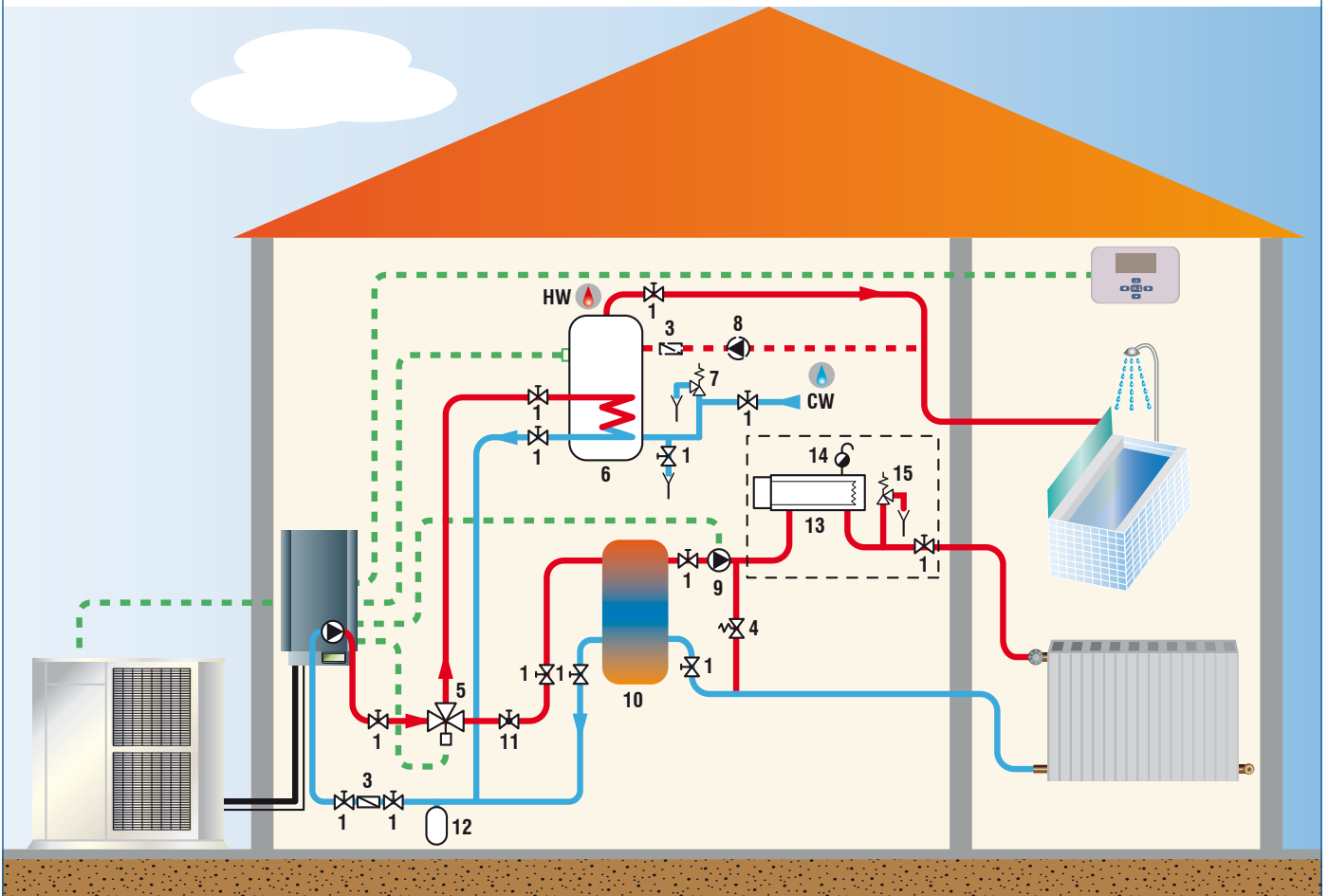

1	Stop valve	11	Flow regulating valve
3	Filter or sludge trap	12	Expansion tank
4	Relief valve	13	In-line heater
5	3-way valve - Domestic hot water	14	Bleed
6	Domestic hot water tank	15	Safety valve
7	Safety devices	🔥	HW : Hot Water
8	Recycling circulating pump (optional)	💧	CW : Cold Water
9	Circulation pump	*	Installation components not supplied
10	Mixing tank		

Layout 3 : Application with control, room by room

This layout is also recommended for heating installations with wide operating water flow variations (radiator thermostatic valves present in the system). Minimum system volume is guaranteed by a mixing tank (10). Take care when calculating the volume of water in the installation and only take account of 50% of the mixing tank's volume.

Example : For a useful volume of 100 litres the actual mixing tank volume will be 200 litres.

The flow adjustment valve (11) is used to balance the flow in heating mode and domestic hot water mode to always ensure optimum Aqu@Scop HT Split operation.

General Hydraulic Layout for a Type 4 (*) Installation - Aqu@Scop HT Split

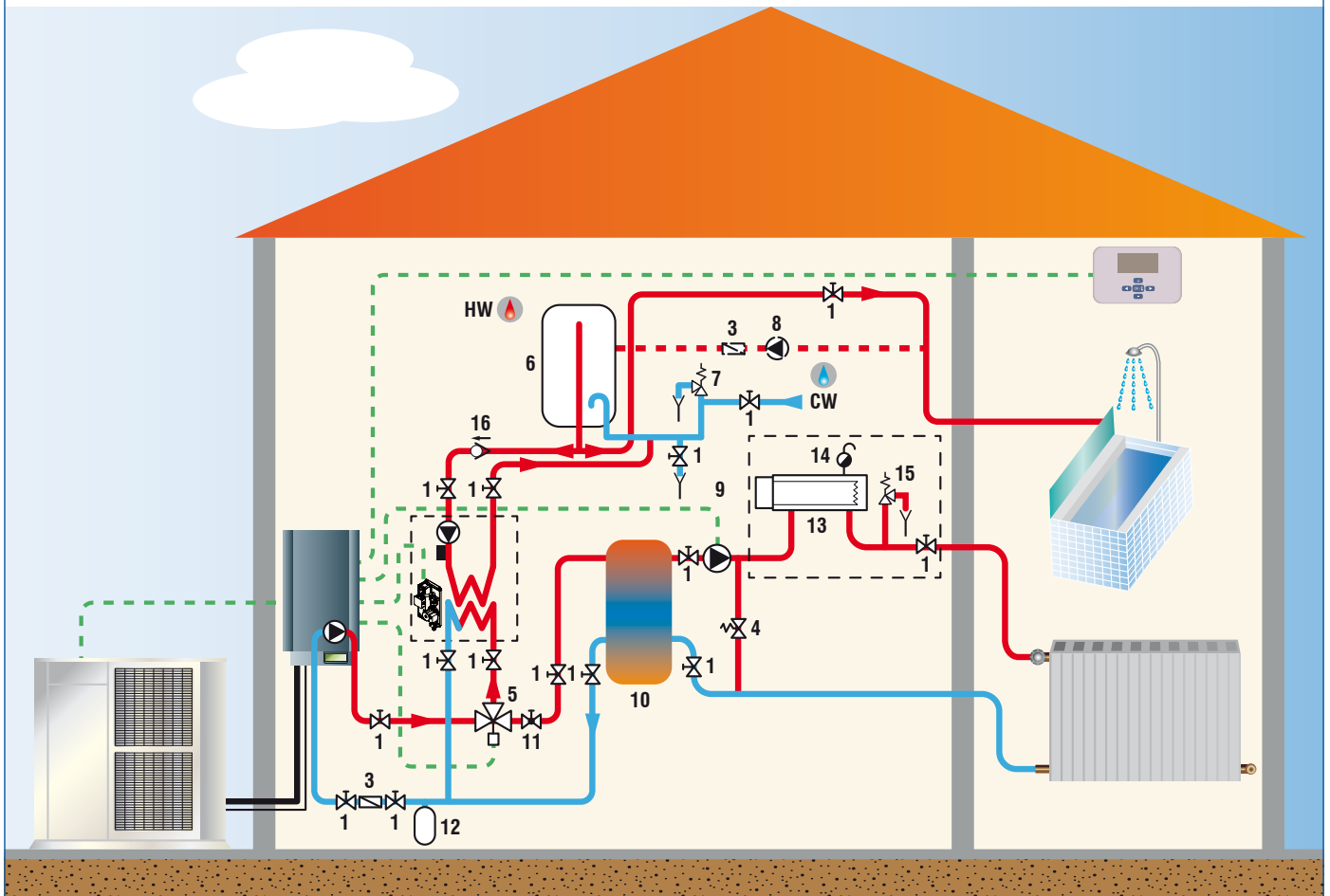

1	Stop valve	11	Flow regulating valve
3	Filter or sludge trap	12	Expansion tank
4	Relief valve	13	In-line heater
5	3-way valve - Domestic hot water	14	Bleed
6	Domestic hot water tank	15	Safety valve
7	Safety devices	16	Check valve
8	Recycling circulating pump (optional)	HW	Hot Water
9	Circulation pump	CW	Cold Water
10	Mixing tank	*	Installation components not supplied

Layout 4 : Domestic hot water (DHW) production with the help of plate heat exchanger kit mounted on existing domestic hot water tank

Example for wall mounted tank (bottom domestic hot water outlet).

Ground mounted tank (top domestic hot water outlet) requires a different kit. Please refer to relative documentation.

General Hydraulic Layout - Aqu@Scop HT Split with Boiler Relief

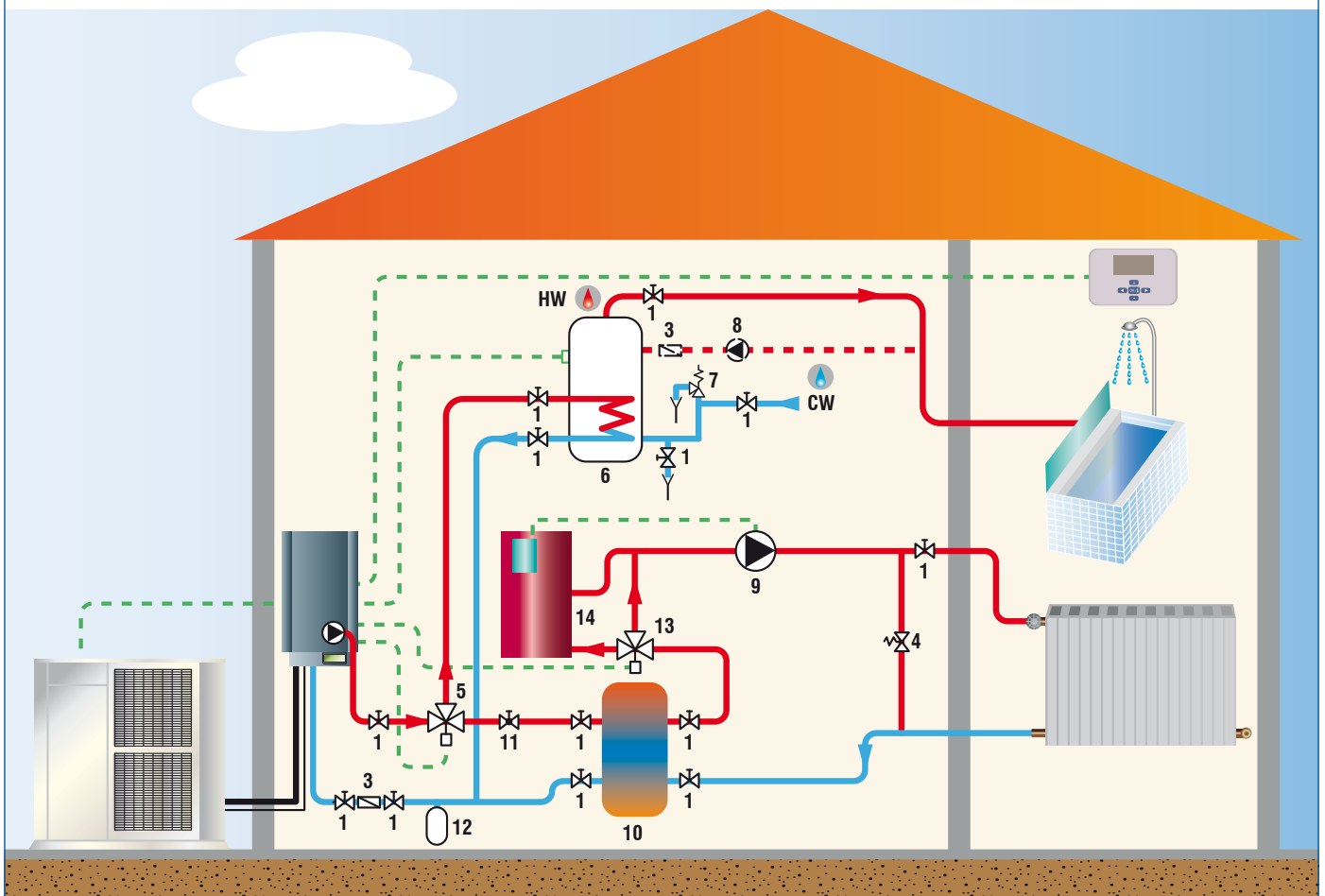

1	Stop valve	10	Mixing tank
3	Filter or sludge trap	11	Flow regulating valve
4	Relief valve	12	Expansion tank
5	3-way valve - Domestic hot water	13	3-way valve - Boiler relief
6	Domestic hot water tank	14	Boiler
7	Safety devices	🔥	HW : Hot Water
8	Recycling circulating pump (optional)	💧	CW : Cold Water
9	Circulation pump		

Aqu@Scop HT Split with Boiler relief

We recommend the installation of the zone valve to avoid heat loss through the boiler when the Aqu@Scop HT Split is only operating.

All the components will be sized to limit pressure drops.

The flow in the heating circuit is normally provided by the circulating pump in place in the installation (recommended) or by the circulating pump of the Aqu@Scop HT Split; in this case ensure that the available pressure of the circulating pump is sufficient.



The small volume of water added by the presence of Aqu@Scop HT Split does not require the replacement of existing expansion tank.

Important : The optional hydraulic kit allows the circuit to be prepared for connecting the Aqu@Scop HT Split in accordance with our recommendations. The hydraulic kit is available with or without a boiler valve.

Note : The installation components will be provided by the installer.

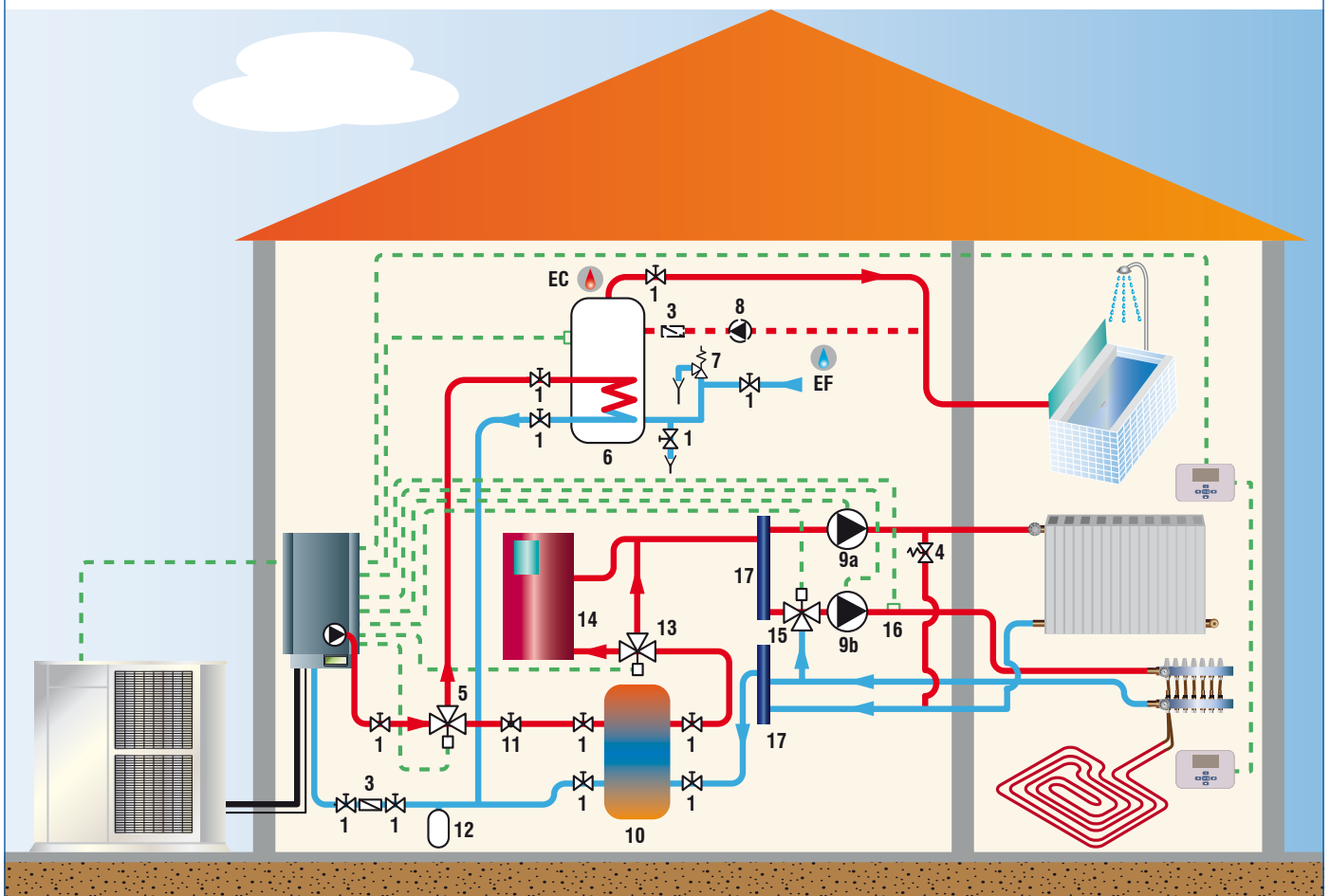
General Hydraulic Layout - Aqu@Scop HT Split in Dual Zone Configuration (under floor heating + radiators)



1	Stop valve	11	Flow regulating valve
3	Filter or sludge trap	12	Expansion tank
4	Relief valve	13	3-way valve - Boiler relief
5	3-way valve - Domestic hot water	14	Boiler
6	Domestic hot water tank	15	3-way modulating valve - Low temperature zone (under floor heating)
7	Safety devices	16	Under floor heating leaving sensor (DZWT)
8	Recycling circulating pump (optional)	17	Header
9	Circulation pump (a : radiator - b : under floor heating)		HW : Hot Water
10	Mixing tank		CW : Cold Water

Aqu@Scop HT Split in dual zone configuration (under floor heating + radiators)

Aqu@Scop HT Split manages a radiator zone (high temperature) and an under floor heating area (low temperature) using a floor leaving sensor, a 3-way modulating valve (3-point 230V motor) and a circulating pump per zone.

Each zone can be controlled by a dedicated room terminal, then allowing the Aqu@Scop HT Split to manage two independent water laws. When the radiators area is off, the Aqu@Scop HT Split automatically switches to the water law of under floor heating optimizing the seasonal COP of the installation.

Note : The installation components will be provided by the installer.

Operating Limits

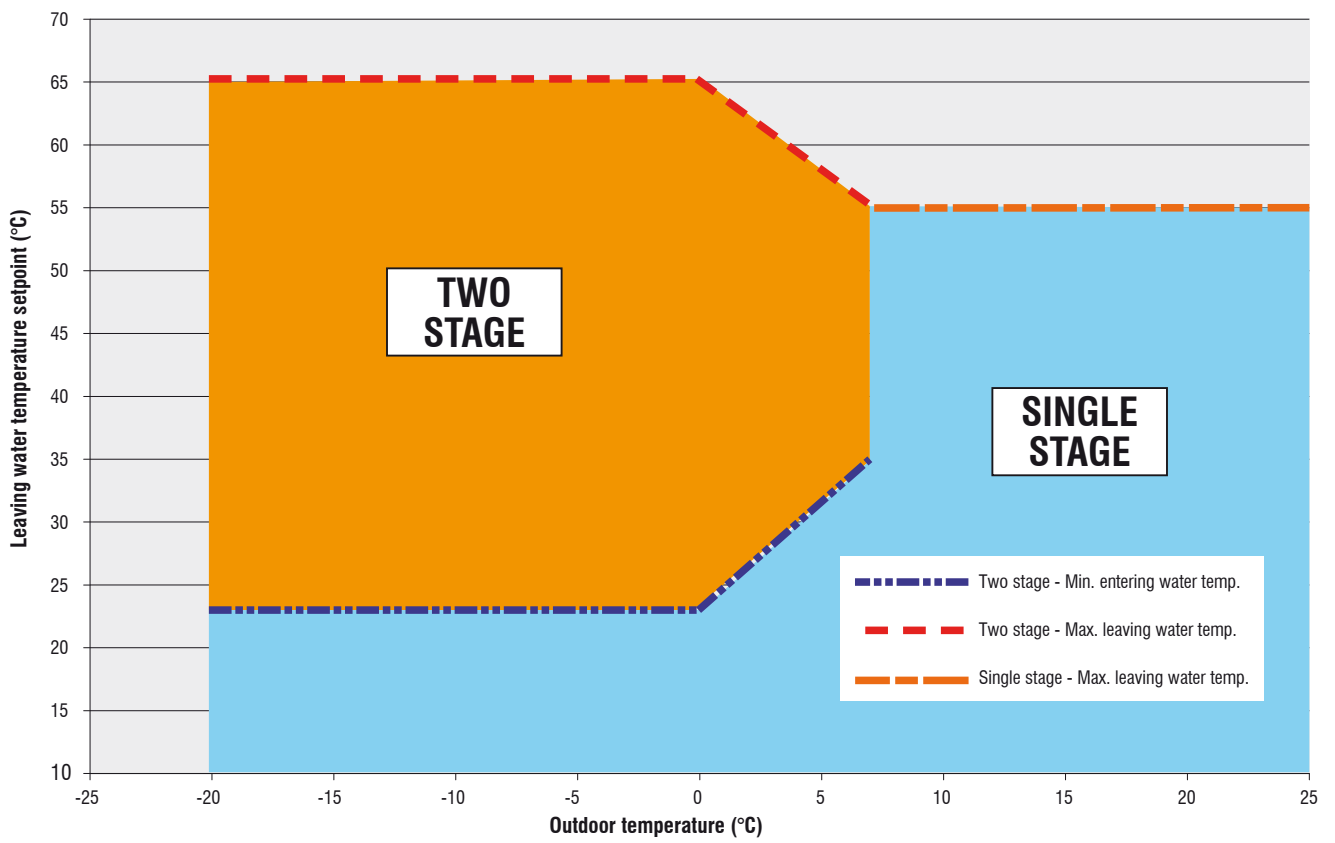

Physical Data - Aqu@Scop HT V2

AQU@SCOP HT V2 MODELS		12-6	14-7*	18-9
REFRIGERANT				
Type		R407C		
Factory charge	g	See nameplate		
HYDRAULIC CONNECTIONS				
Water inlet	gas	1" Female		
Water outlet	gas	1" Female		
WATER FLOW				
Nominal	l/h	1030	1370	1580
Minimum	l/h	890	1170	1340
Maximum	l/h	1160	1530	1775
FANS				
Fans (x2)		206 W - 700 rpm - 6000 m ³ /h		
SOUND LEVELS				
Sound power levels	dB(A)	67	67	67

This equipment contains fluorinated greenhouse effect gas under the Kyoto Protocol.

Electrical Data - Aqu@Scop HT V2

AQU@SCOP HT V2 MODELS		12-6	14-7	18-9
SUPPLY VOLTAGE 400 V/3 Ph/50 Hz				
Starting current with limiter	A		< 60	
Max. current	A	15	16	18
SUPPLY VOLTAGE 230 V/ 1 Ph/50 Hz				
Starting current with limiter	A		< 45	
Max. current	A	28	32	-

Physical Data - Aqu@Scop HT Split

Outdoor unit

AQU@SCOP HT SPLIT MODELS		12-6	14-7	18-9
REFRIGERANT				
Type		R407C		
Factory charge for pipings from 0 up to 20 metres	g	See nameplate		
Additional charge for pipings from 20 to 45 metres	g	See chapter "Refrigerant Pipings and Additional Charges"		
REFRIGERANT CONNECTIONS				
Gas refrigerant piping (0 to 25 metres)	inch	5/8		
Liquid refrigerant piping (0 to 25 metres)	inch	3/8		
Gas refrigerant pipings (0 to 45 metres)	inch	3/4		
Liquid refrigerant piping (0 to 45 metres)	inch	1/2		
FANS				
Fans (x2)		206 W - 700 rpm - 6000 m ³ /h		
SOUND LEVELS				
Outdoor unit sound power levels	dB(A)	65	65	65

This equipment contains fluorinated greenhouse effect gas under the Kyoto Protocol.

Indoor unit

AQU@SCOP HT SPLIT MODELS		12-6*	14-7*	18-9
REFRIGERANT CONNECTIONS				
Gas line	inch	5/8		
Liquid line	inch	3/8		
HYDRAULIC CONNECTIONS				
Inlet water	gas	1" female / Rotating nut		
Outlet water	gas	1" female / Rotating nut		
WATER FLOW				
Nominal	l/h	1030	1370	1580
Minimum	l/h	890	1170	1340
Maximum	l/h	1160	1530	1775
SOUND LEVELS				
Indoor unit sound power levels	dB(A)	41	41	41

* Indoor unit is common for outdoor units 12-6 and 14-7.

Electrical Data - Aqu@Scop HT Split

Outdoor unit

AQU@SCOP HT SPLIT MODELS		12-6	14-7	18-9
POWER SUPPLY 400 V/3 Ph/50 Hz				
Starting current with limiter	A	< 60		
Max. current - Outdoor unit only	A	12.2	13.2	15.2
Max. current. - Outdoor unit + Indoor unit + Accessories*	A	15.5	16.5	18.5
POWER SUPPLY 230 V/ 1 Ph/50 Hz				
Starting current with limiter	A	< 45		
Max. current - Outdoor unit only	A	25.7	27.2	-
Max. current - Outdoor unit + Indoor unit + Accessories*	A	29	30.5	-

* Depending on system configuration, the indoor unit can be separately powered or powered from the outdoor unit (one upstream general protection only).

Indoor unit

AQU@SCOP HT SPLIT MODELS		12-6	14-7	18-9
POWER SUPPLY 230 V/ 1 Ph/50 Hz				
Max. current - Indoor unit only	A	1.8	1.8	1.8
Max. current - Indoor unit + Accessories	A	3.3	3.3	3.3

Performance Data - Aqu@Scop HT V2

AQU@SCOP HT V2 MODELS		12-6	14-7	18-9	
Outdoor air condition +7 °C / +6 °C WB	Water condition 30/35 °C				
	Heating capacity single-compressor	kW	6.43	8.51	9.90
	Power input	kW	1.53	1.92	2.15
	COP		4.20	4.43	4.61
	Water condition 45 °C				
	Heating capacity single-compressor	kW	5.86	7.93	9.46
	Power input	kW	1.86	2.35	2.67
	COP		3.15	3.37	3.54
	Water condition 55 °C				
Heating capacity dual-compressor	kW	5.36	7.22	8.75	
Power input	kW	2.30	2.85	3.27	
COP with defrost		2.33	2.53	2.68	
Outdoor air condition +2 °C / +1 °C WB	Water condition 35 °C				
	Heating capacity dual-compressor	kW	10.52	13.26	15.63
	Power input	kW	2.99	3.82	4.39
	COP with defrost		3.52	3.47	3.56
Outdoor air condition -7 °C / -8 °C WB	Water condition 35 °C				
	Heating capacity dual-compressor	kW	8.21	10.89	12.46
	Power input	kW	2.78	3.59	4.05
	COP with defrost		2.95	3.03	3.08
	Water condition 55 °C				
	Heating capacity dual-compressor	kW	8.57	10.92	12.69
	Power input	kW	3.74	4.63	5.29
	COP with defrost		2.29	2.36	2.40
	Water condition 65 °C				
	Heating capacity dual-compressor	kW	8.49	10.90	12.25
Power input	kW	4.45	5.30	5.92	
COP with defrost		1.91	2.06	2.07	
Outdoor air condition -15 °C	Water condition 35 °C				
	Heating capacity dual-compressor	kW	7.95	10.44	11.94
	Power input	kW	2.78	3.58	4.04
	COP with defrost		2.86	2.92	2.96
Outdoor air condition -20 °C	Water condition 55 °C				
	Heating capacity dual-compressor	kW	8.03	10.32	11.28
	Power input	kW	3.95	4.73	5.22
	COP with defrost		2.03	2.18	2.16

WB : Wet bulb.

AQU@SCOP HT V2 MODELS		12-6	14-7	18-9
Nominal water flow	m³/h	1030	1370	1580
Available hydraulic pressure - High speed	kPa	55	48	55
Operating limits (outdoor temperature)	°C	-20		
Outlet water temperature Min. / Max.	°C	+25/+65		

Performance Data - Aqu@Scop HT Split

AQU@SCOP HT SPLIT MODELS		12-6	14-7	18-9	
Outdoor air condition +7 °C / +6 °C WB	Water condition 30/35 °C				
	Heating capacity single-compressor	kW	6.30	8.35	9.71
	Power input	kW	1.53	1.92	2.15
	COP		4.12	4.35	4.52
	Water condition 45 °C				
	Heating capacity single-compressor	kW	5.74	7.77	9.27
	Power input	kW	1.86	2.35	2.67
	COP		3.09	3.31	3.47
	Water condition 55 °C				
Heating capacity dual-compressor	kW	5.25	7.08	8.58	
Power input	kW	2.30	2.85	3.27	
COP with defrost		2.28	2.48	2.62	
Outdoor air condition +2 °C / +1 °C WB	Water condition 35 °C				
	Heating capacity dual-compressor	kW	10.31	13.00	15.32
	Power input	kW	2.99	3.82	4.39
	COP with defrost		3.45	3.40	3.49
Outdoor air condition -7 °C / -8 °C WB	Water condition 35 °C				
	Heating capacity dual-compressor	kW	8.05	10.68	12.21
	Power input	kW	2.78	3.59	4.05
	COP with defrost		2.90	2.97	3.02
	Water condition 55 °C				
	Heating capacity dual-compressor	kW	8.40	10.71	12.44
	Power input	kW	3.74	4.63	5.29
	COP with defrost		2.25	2.31	2.35
	Water condition 65 °C				
	Heating capacity dual-compressor	kW	8.33	10.69	12.01
Power input	kW	4.45	5.30	5.92	
COP with defrost		1.87	2.02	2.03	
Outdoor air condition -15 °C	Water condition 35 °C				
	Heating capacity dual-compressor	kW	7.79	10.24	11.71
	Power input	kW	2.78	3.58	4.04
	COP with defrost		2.80	2.86	2.90
Outdoor air condition -20 °C	Water condition 55 °C				
	Heating capacity dual-compressor	kW	7.87	10.12	11.06
	Power input	kW	3.95	4.73	5.22
	COP with defrost		1.99	2.14	2.12

WB : Wet bulb.

AQU@SCOP HT SPLIT MODELS		12-6	14-7	18-9
Nominal water flow	m³/h	1030	1370	1580
Available hydraulic pressure - High speed	kPa	55	48	55
Operating limits (outdoor temperature)	°C	-20		
Outlet water temperature Min. / Max.	°C	+25/+65		

Performance Curves - Aqu@Scop HT V2 12-6

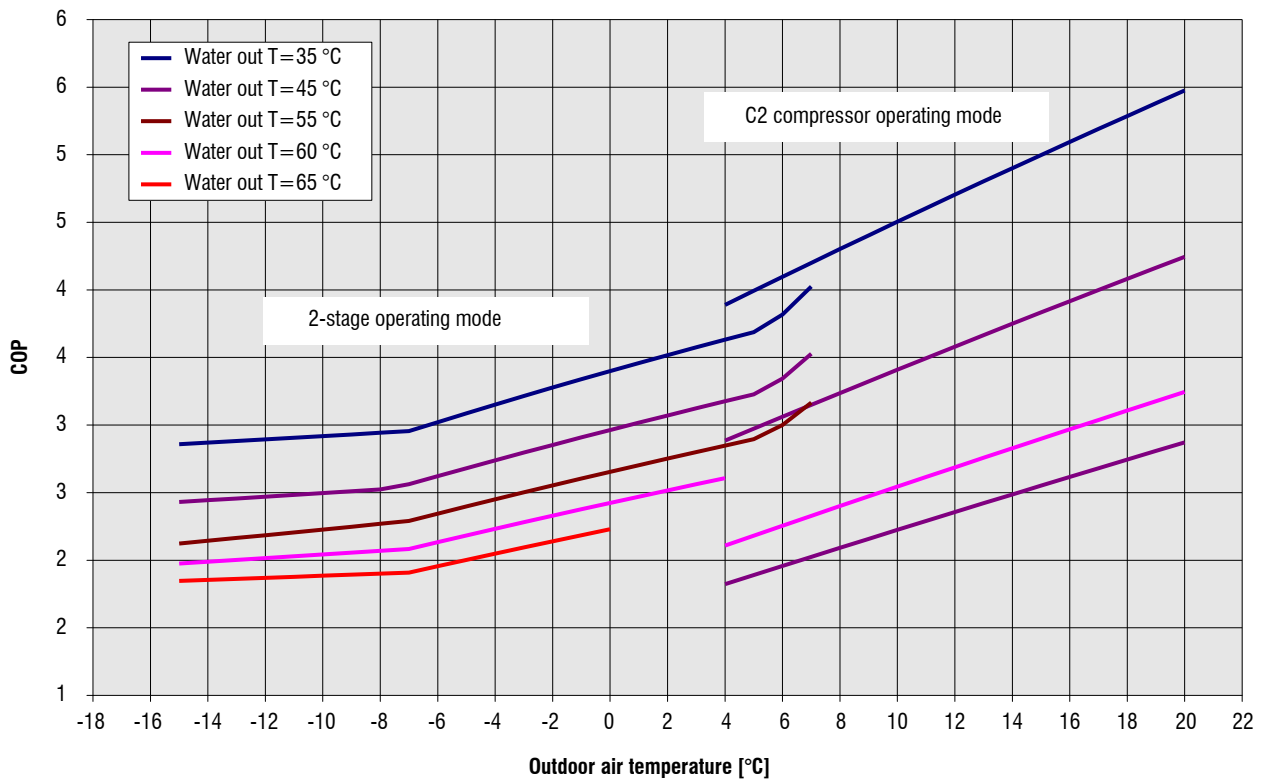
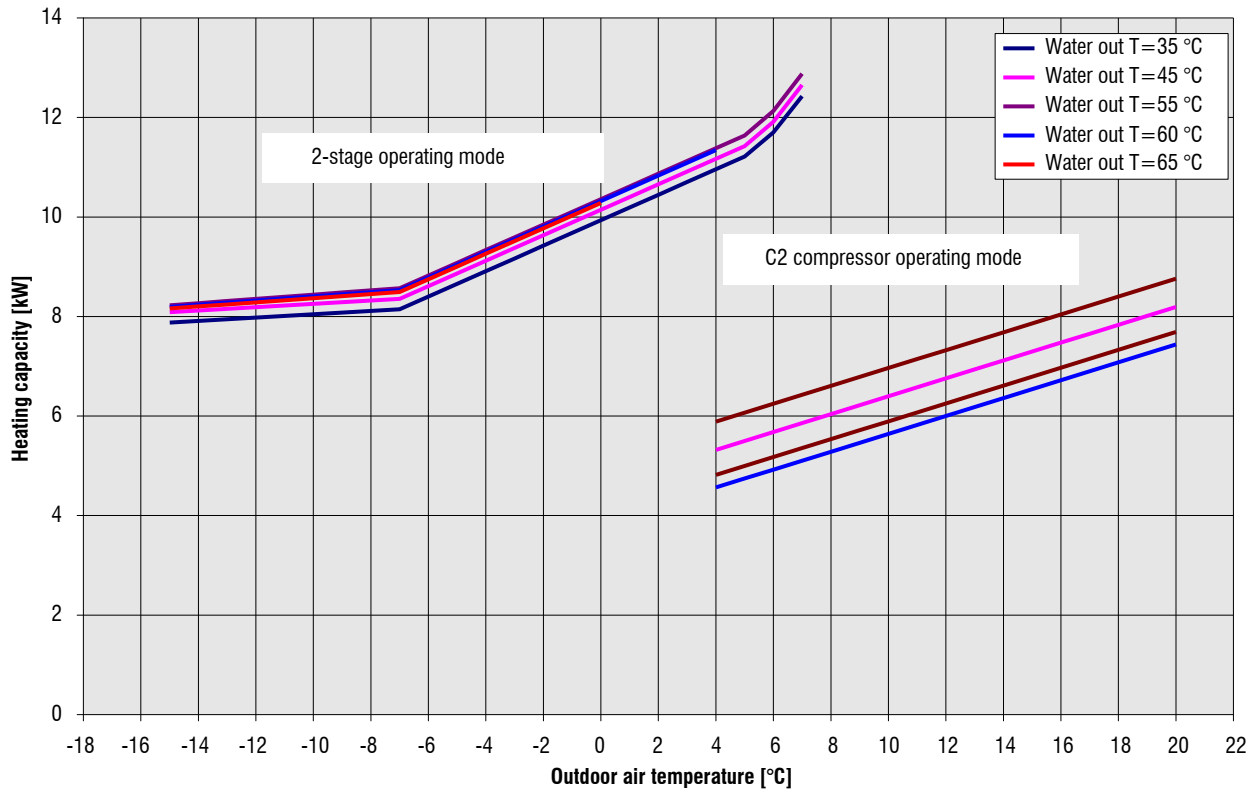

Performance Curves - Aqu@Scop HT Split 12-6

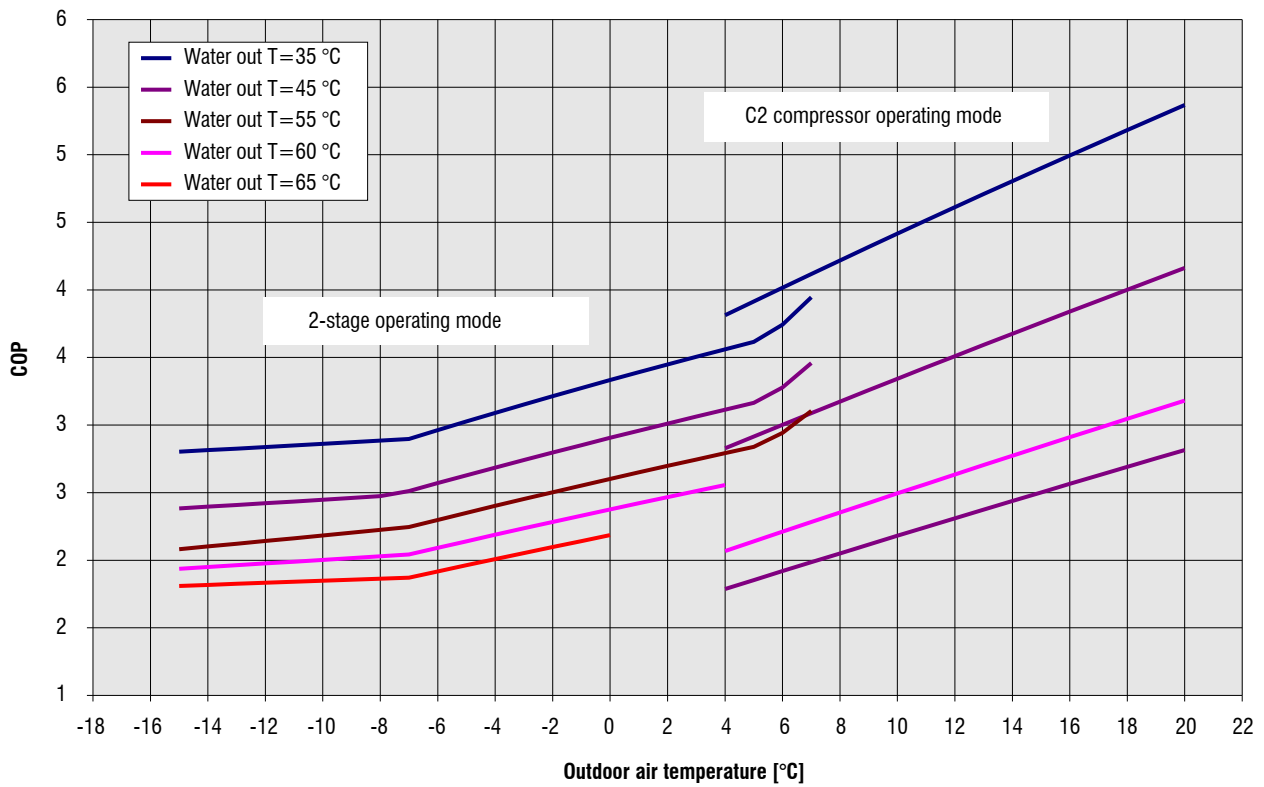
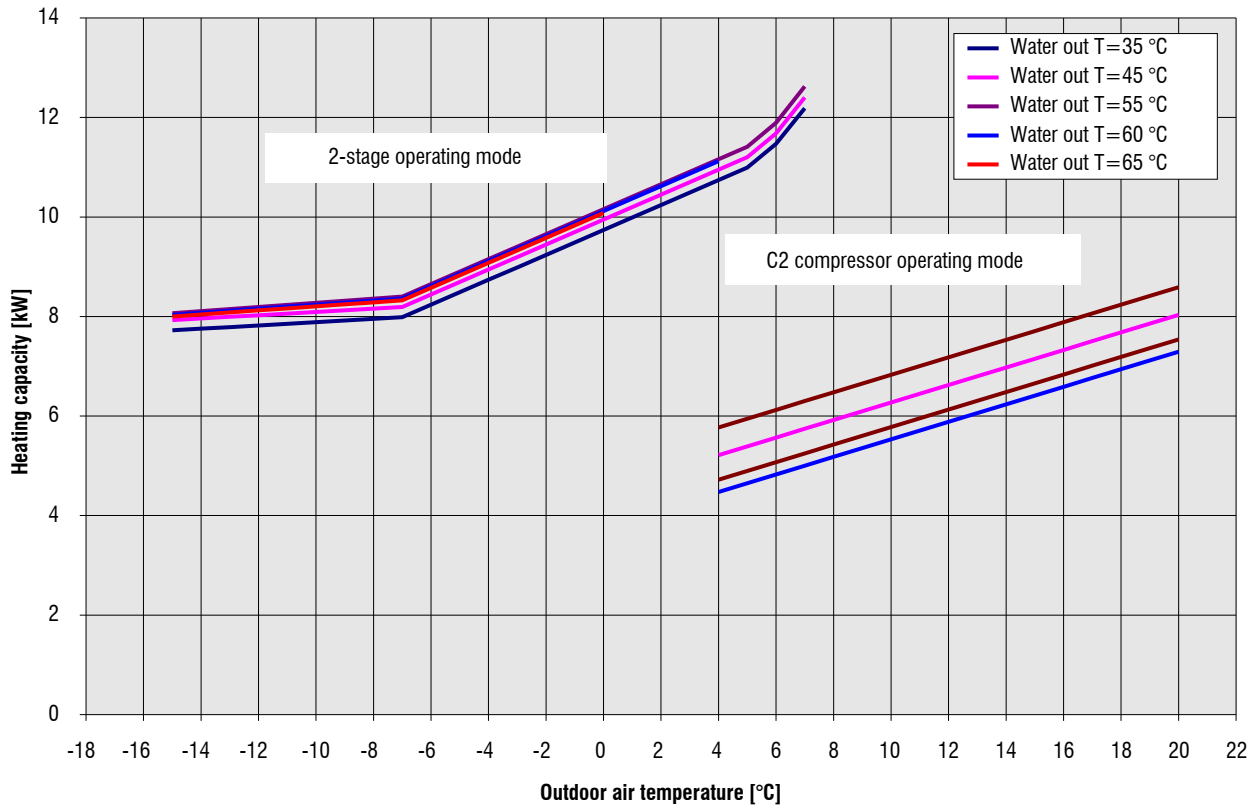

Performance Curves - Aqu@Scop HT V2 14-7

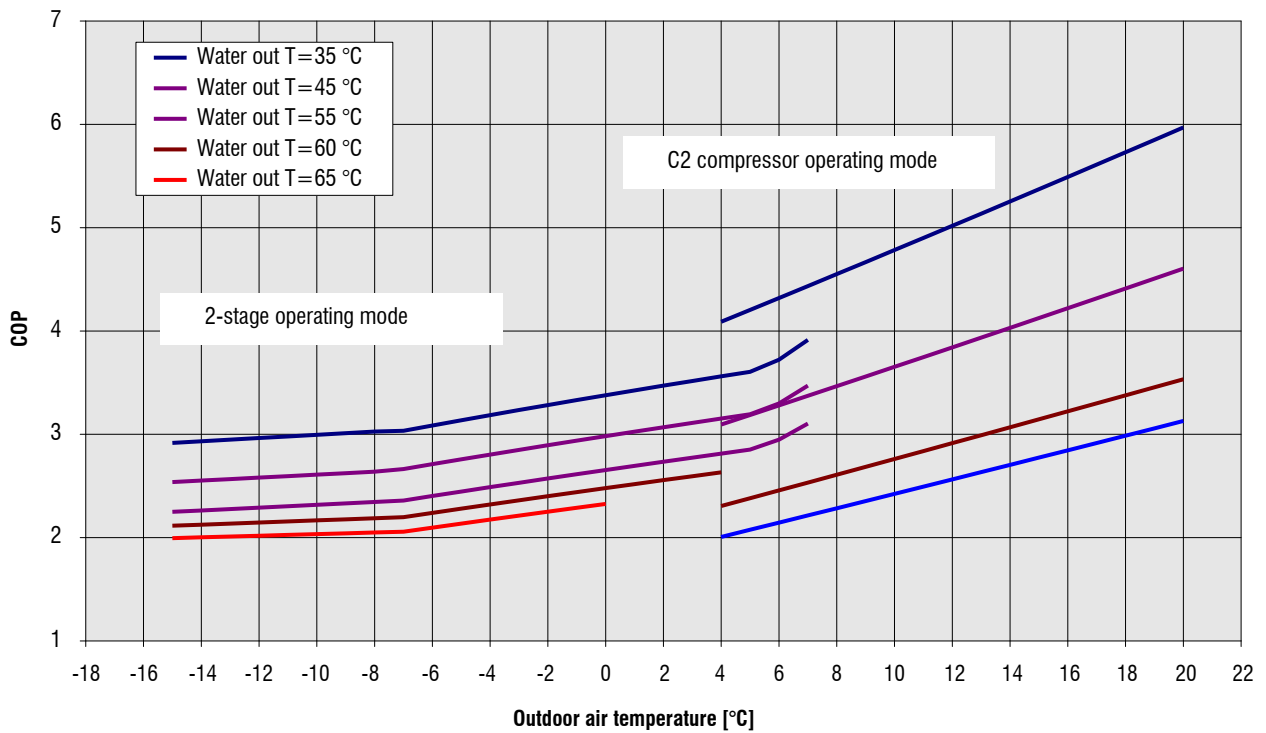
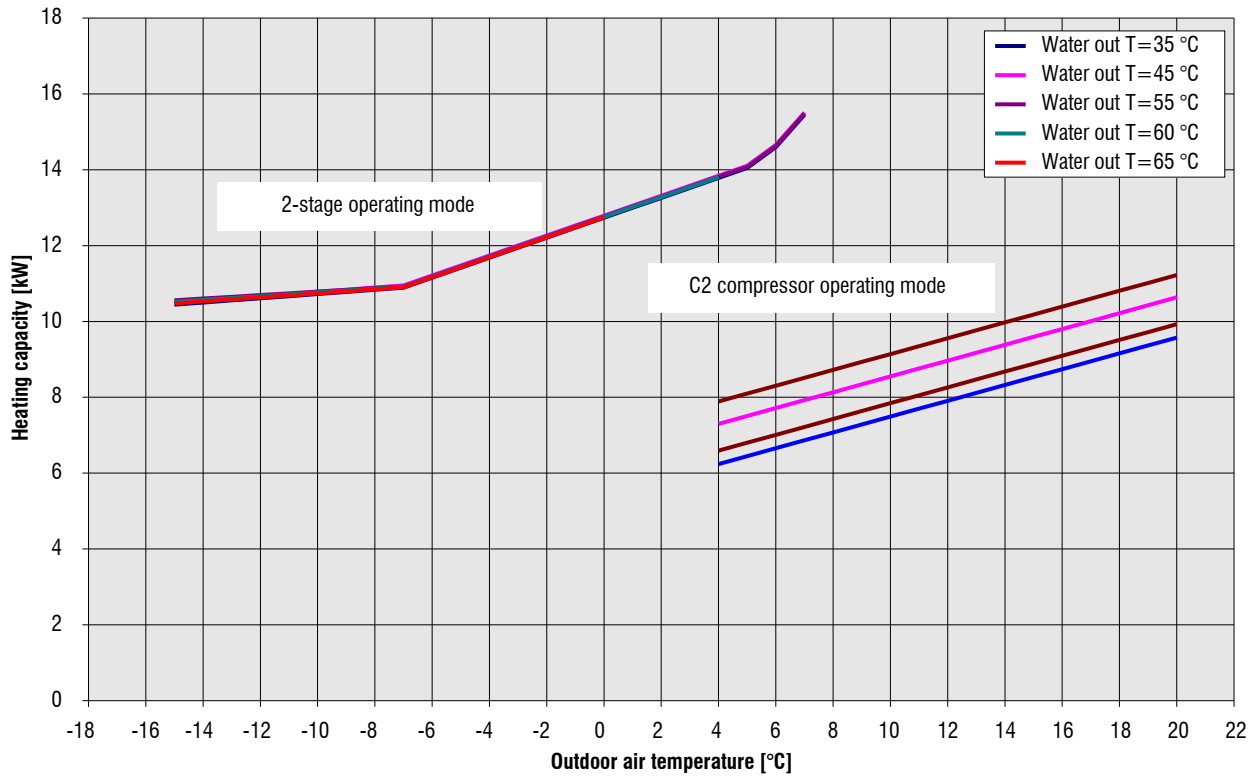

Performance Curves - Aqu@Scop HT Split 14-7

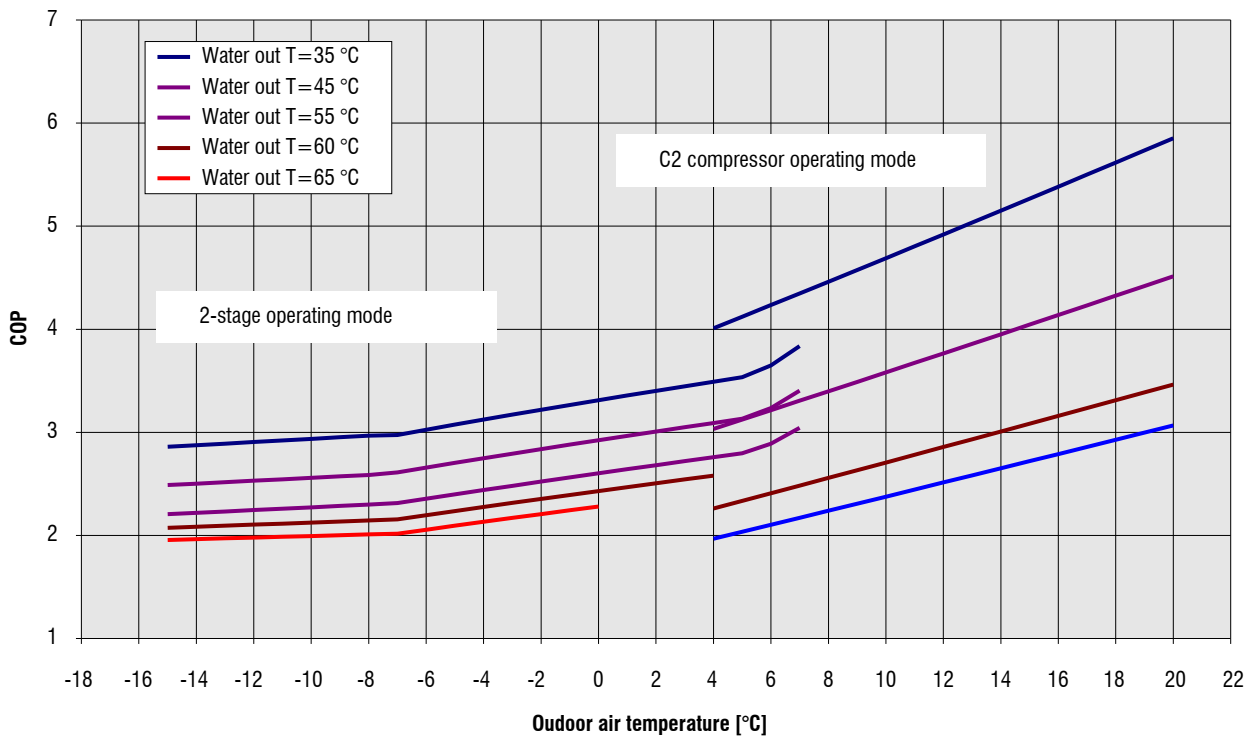
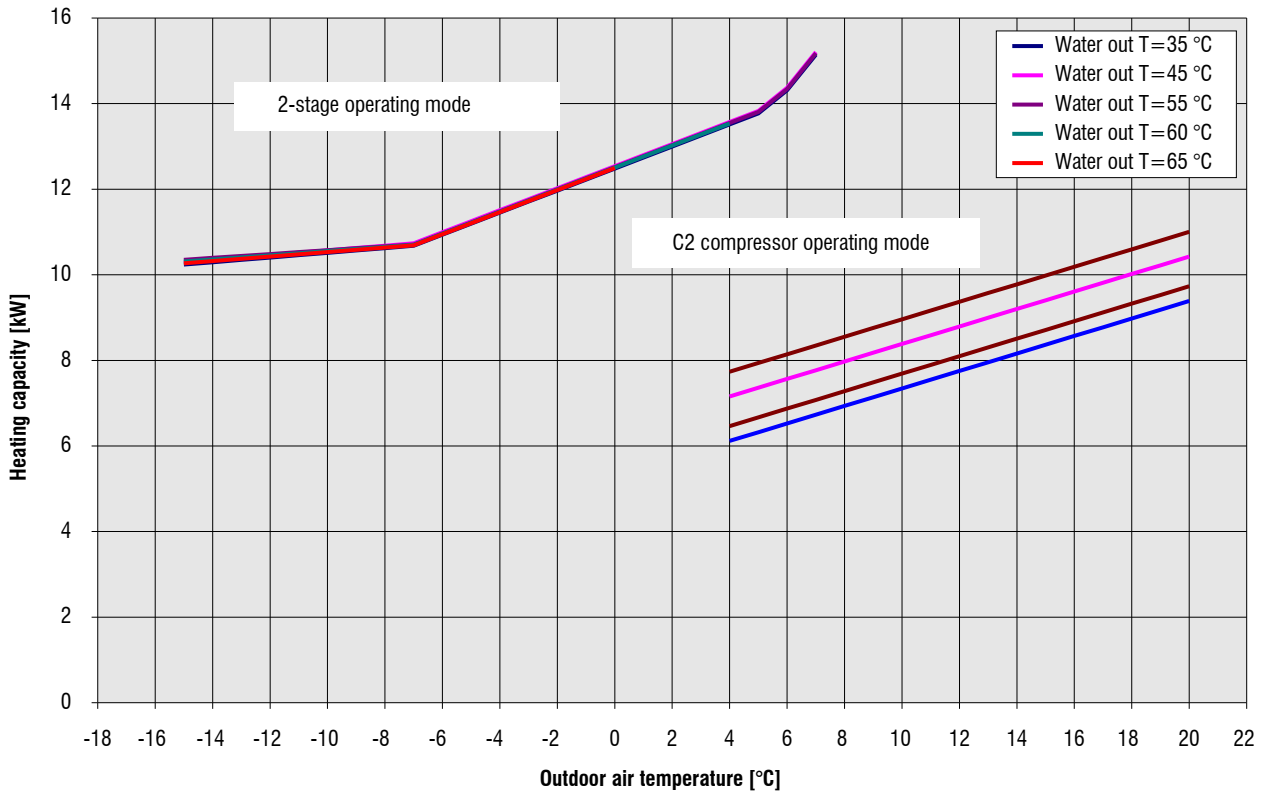

Performance Curves - Aqu@Scop HT V2 18-9

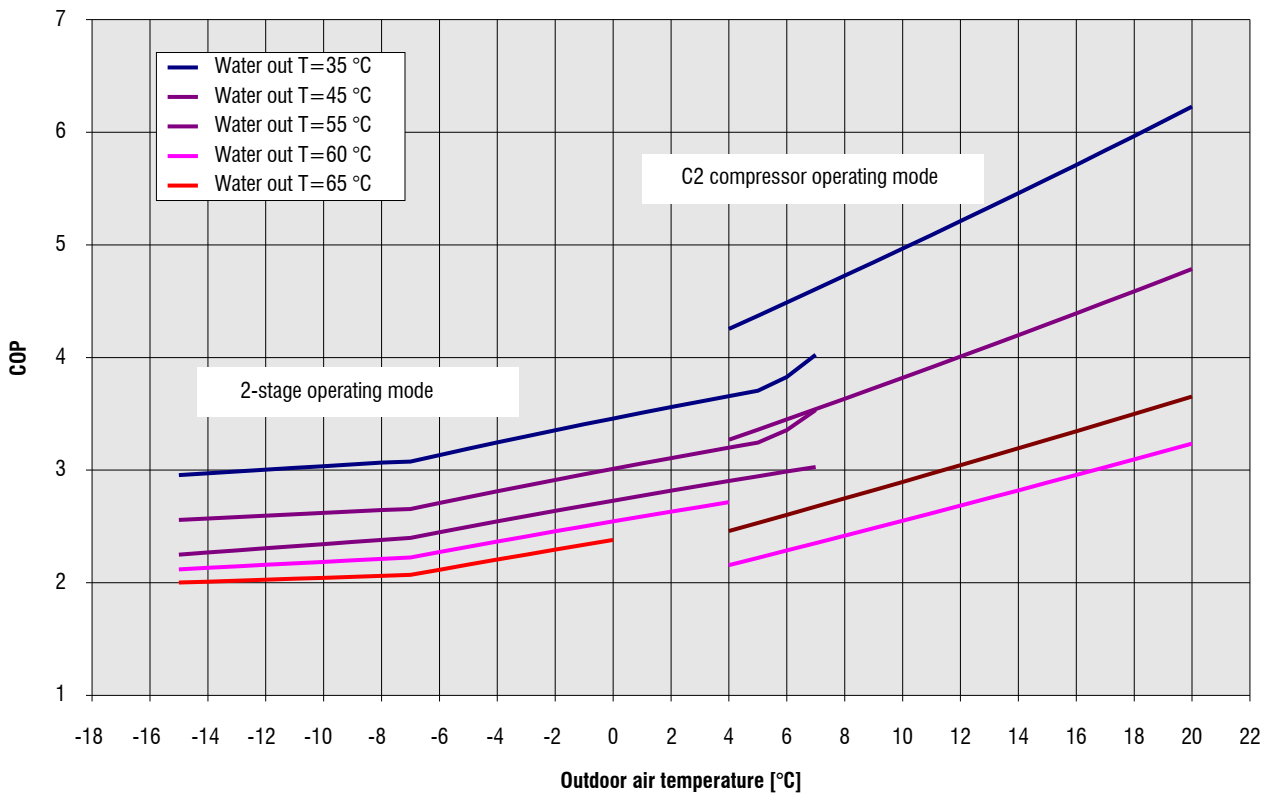
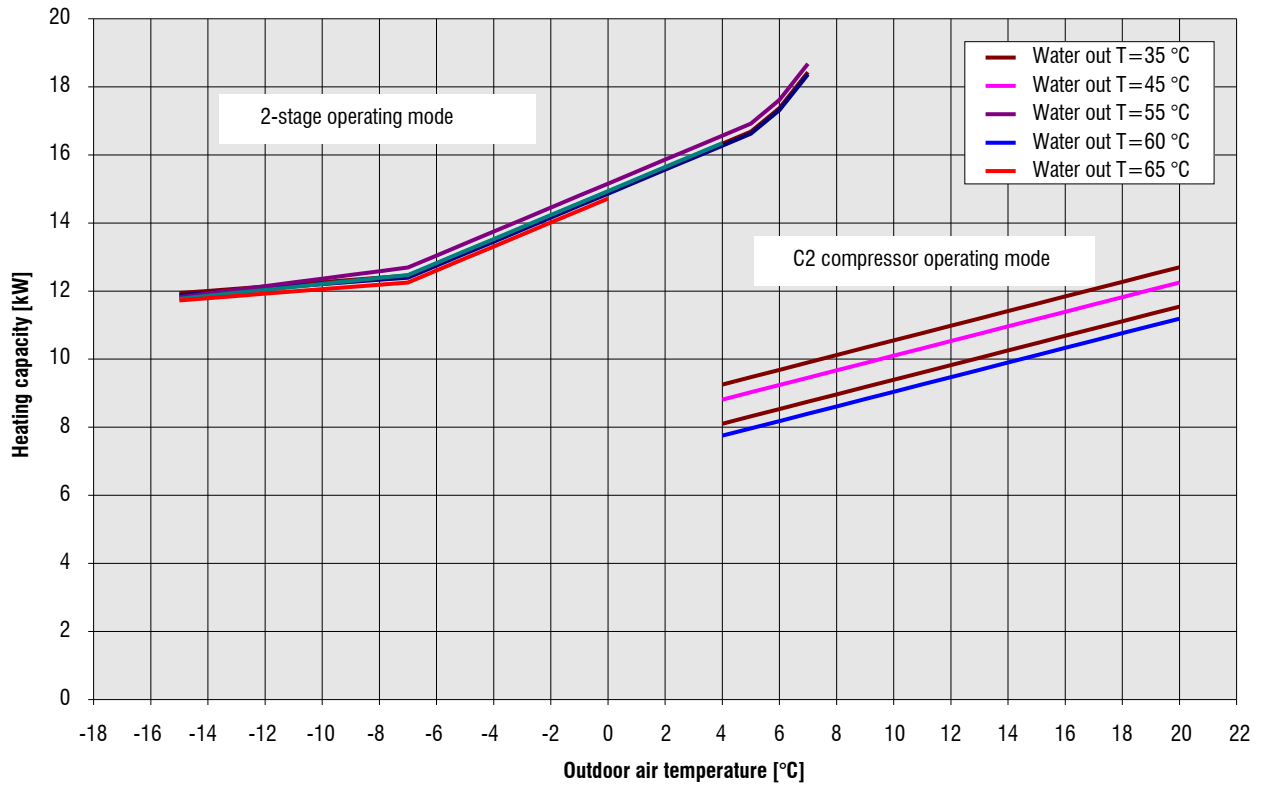

Performance Curves - Aqu@Scop HT Split 18-9

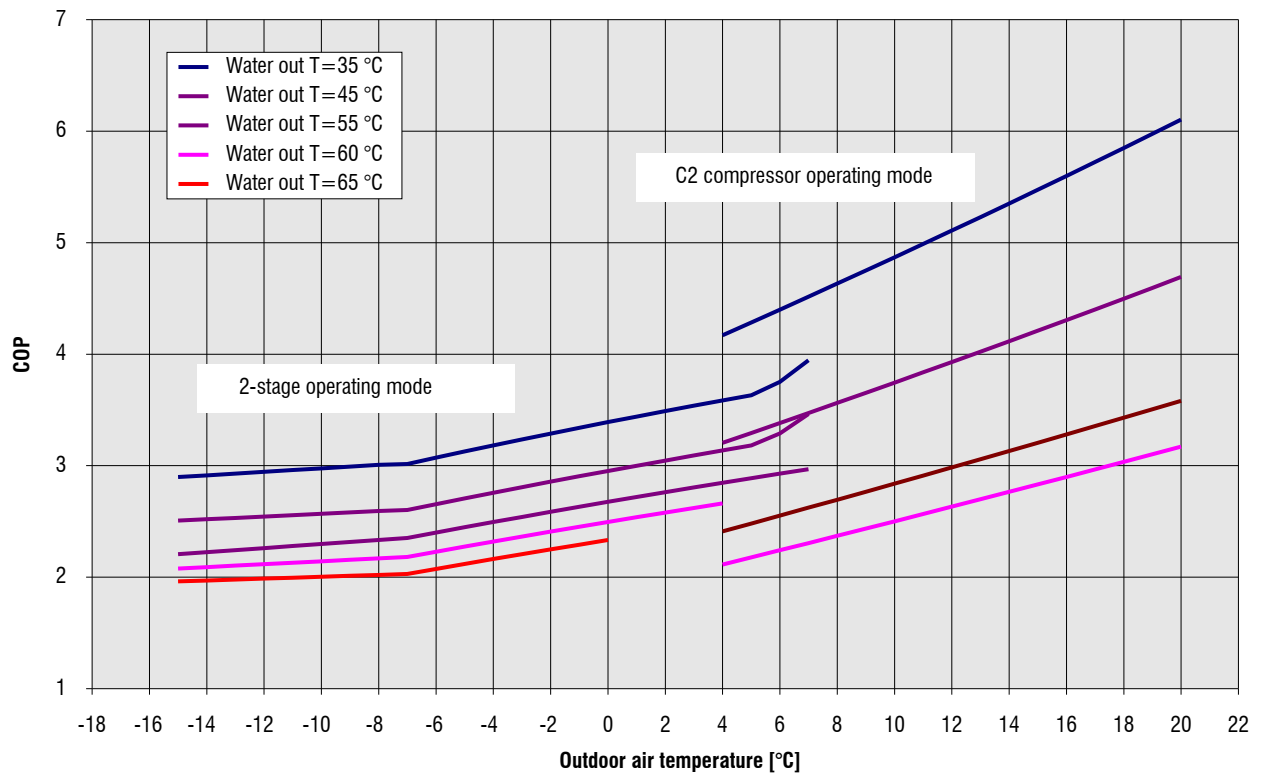
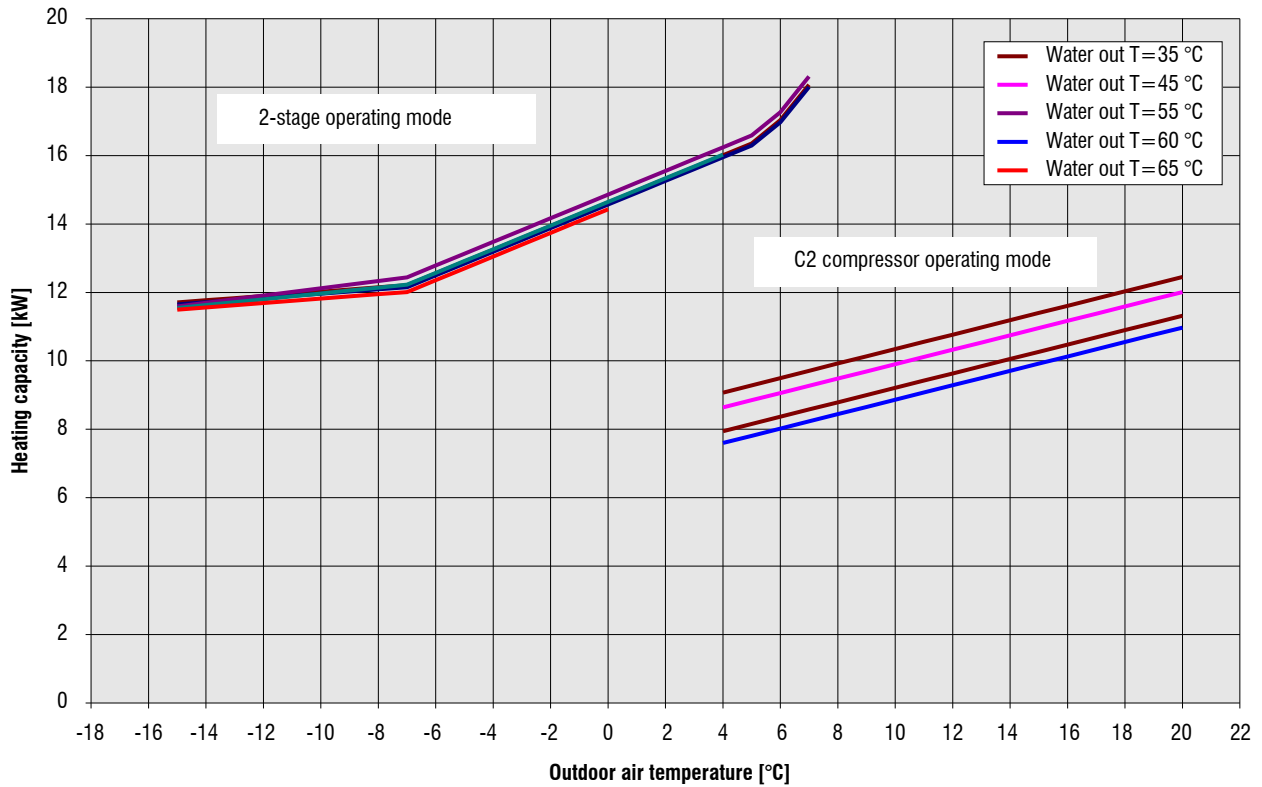

Pressure Drop Curves

Domestic hot water tank (optional)

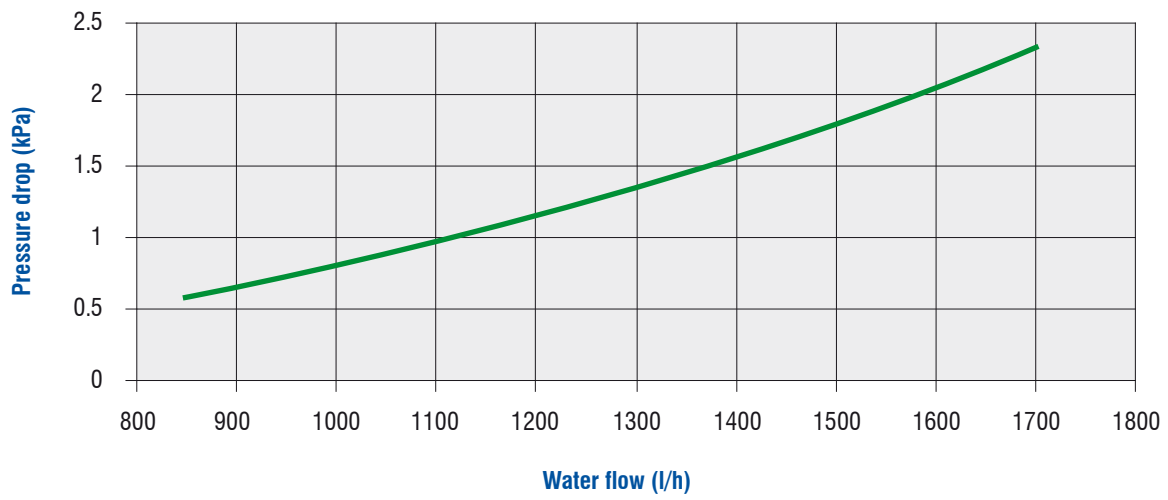

Domestic hot water tank 3-way valve (optional)

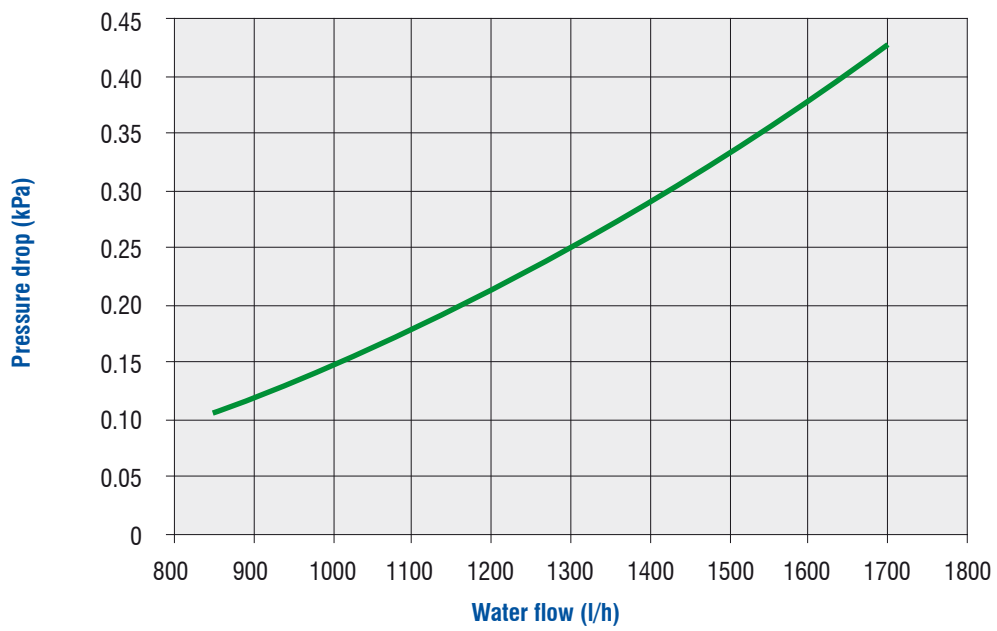

Circulation Pump Available Pressure/Water Flow Curves

Aqu@Scop HT V2 / Aqu@Scop HT Split 12-6

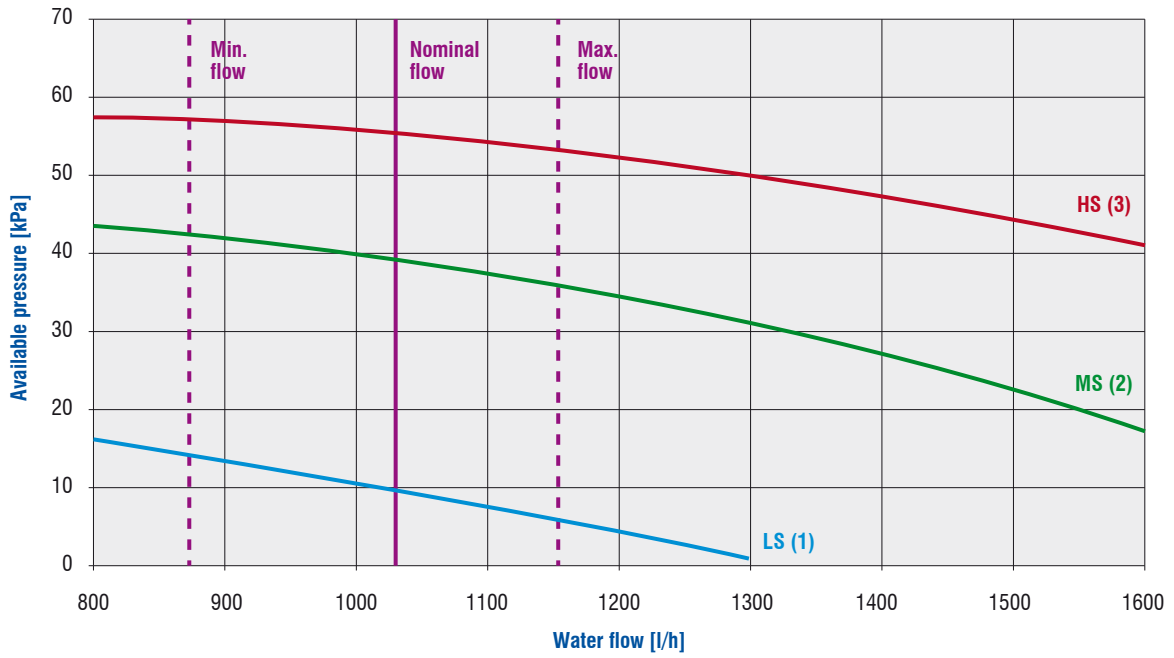

Aqu@Scop HT V2 / Aqu@Scop HT Split 14-7

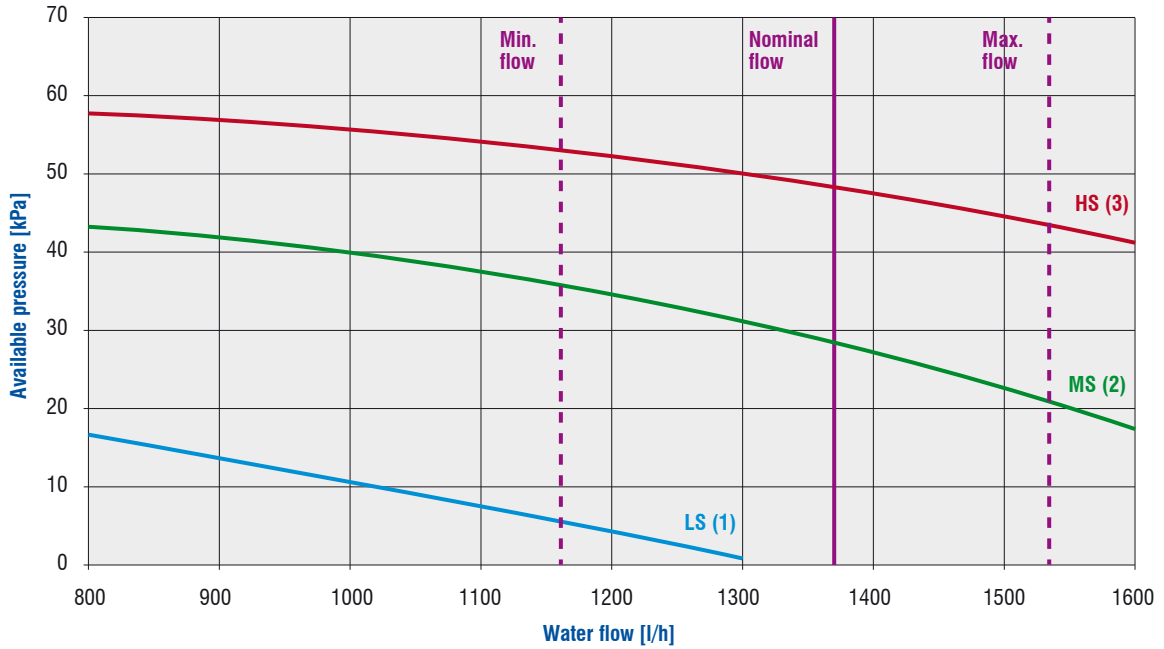

Circulation Pump Available Pressure/Water Flow Curves (continued)

Aqu@Scop HT V2 / Aqu@Scop HT Split 18-9

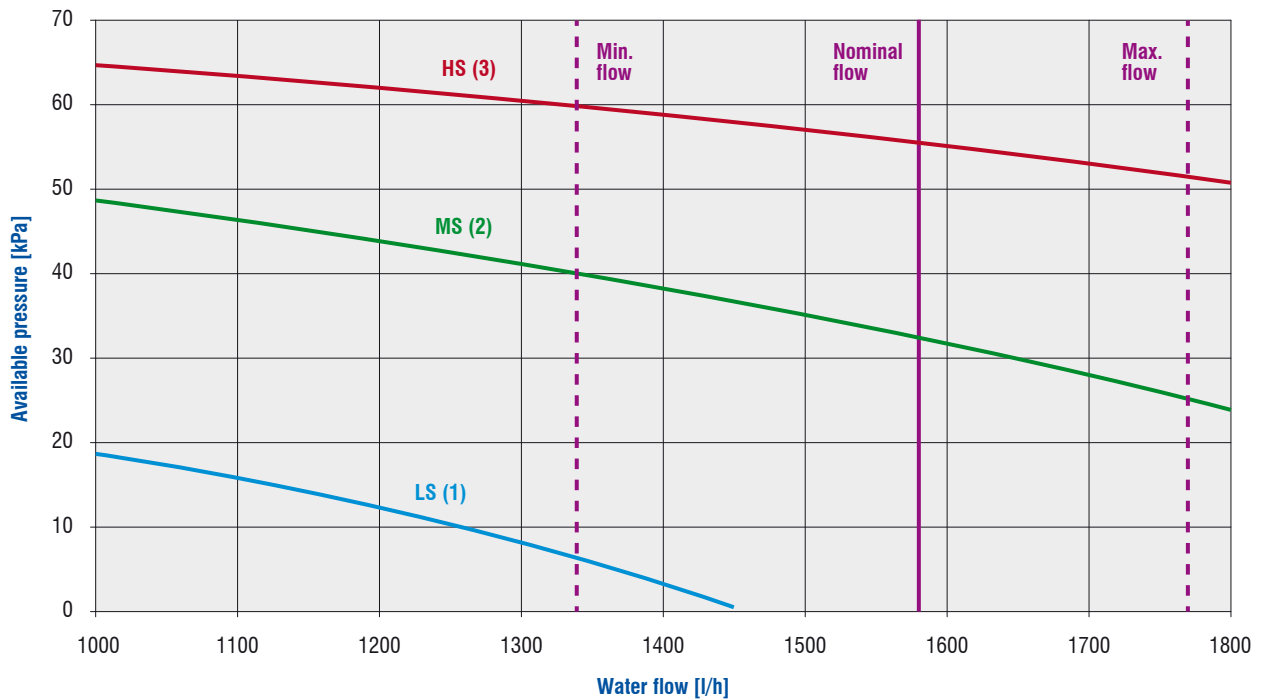

Circulation Pump Power Input

Aqu@Scop HT V2 / Aqu@Scop HT Split - All sizes

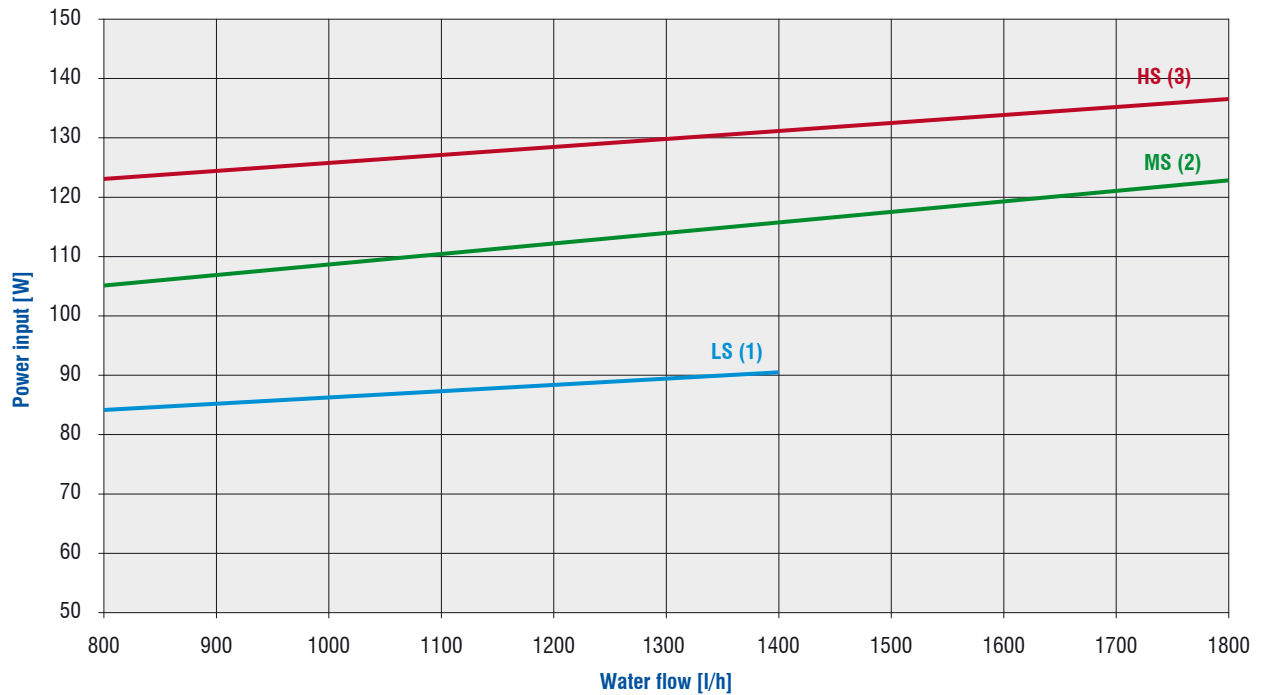

Dimensions Aqu@Scop HT V2

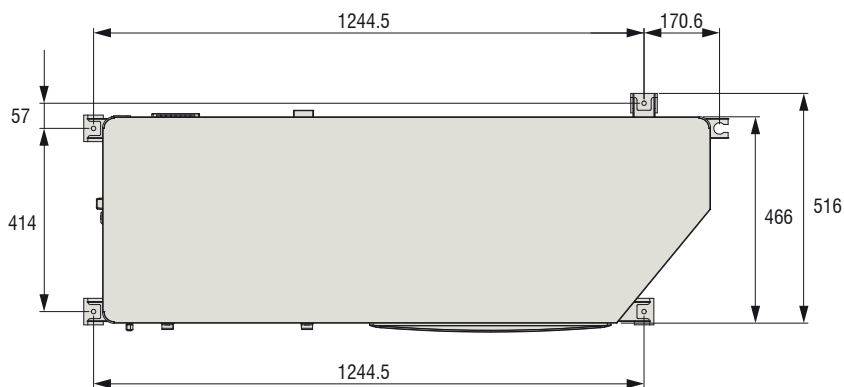
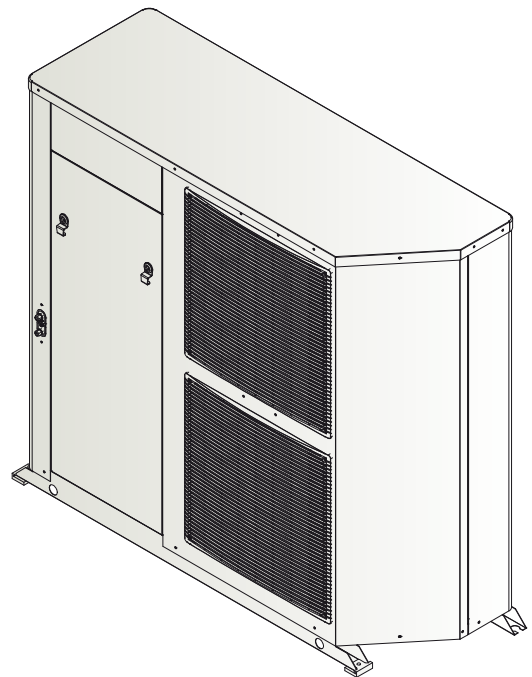
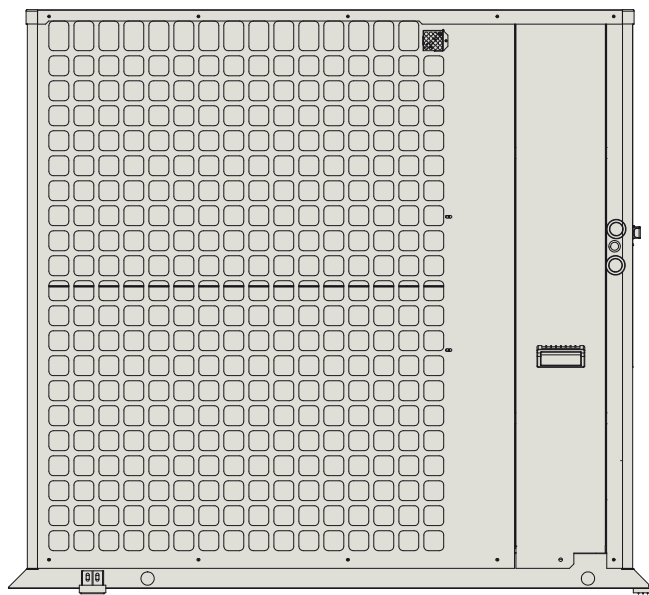
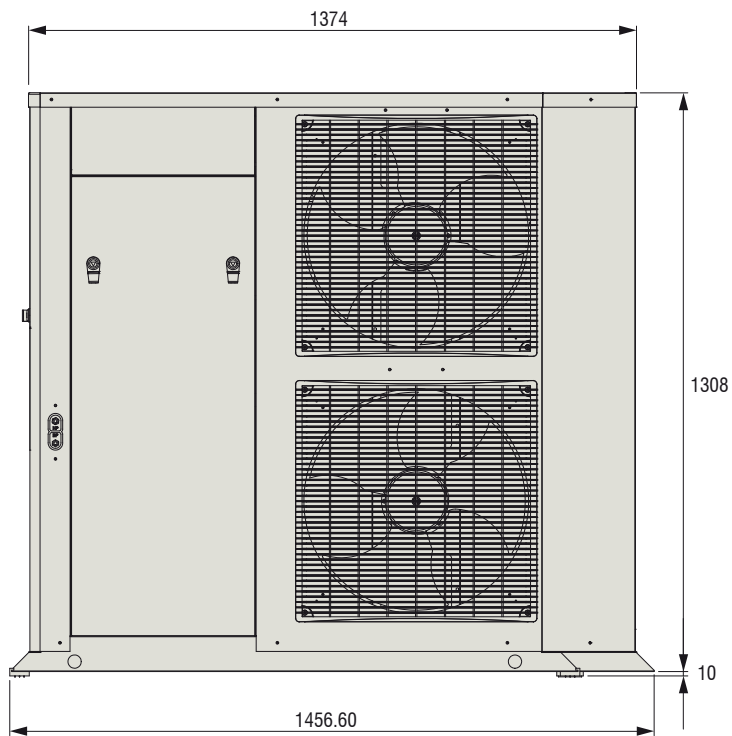

Dimensions Aqu@Scop HT Split - Outdoor Unit

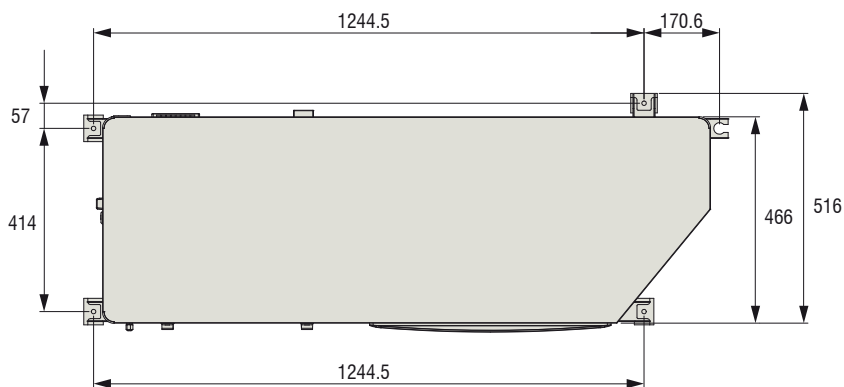
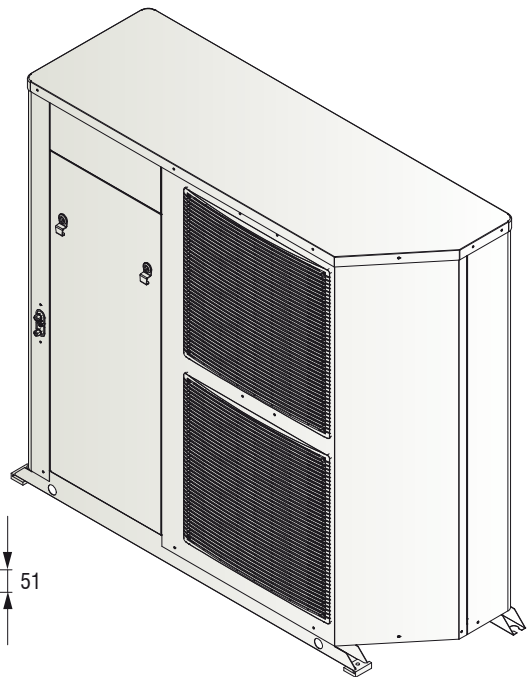
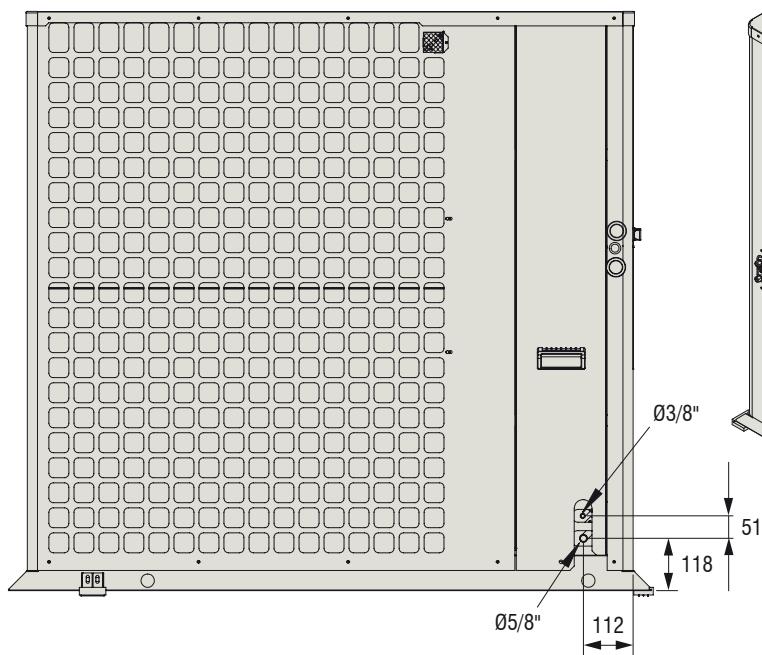
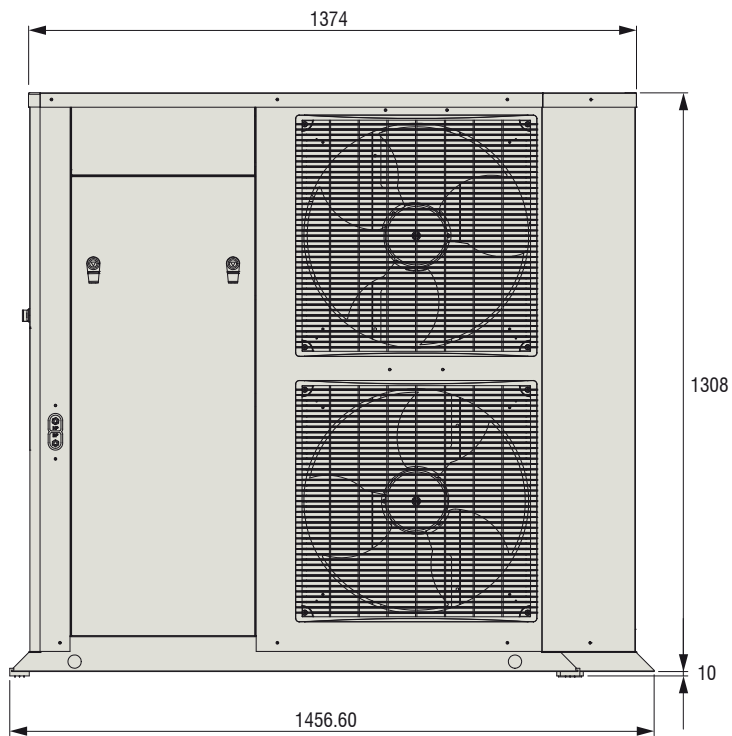

Dimensions Aqu@Scop HT Split - Indoor Unit

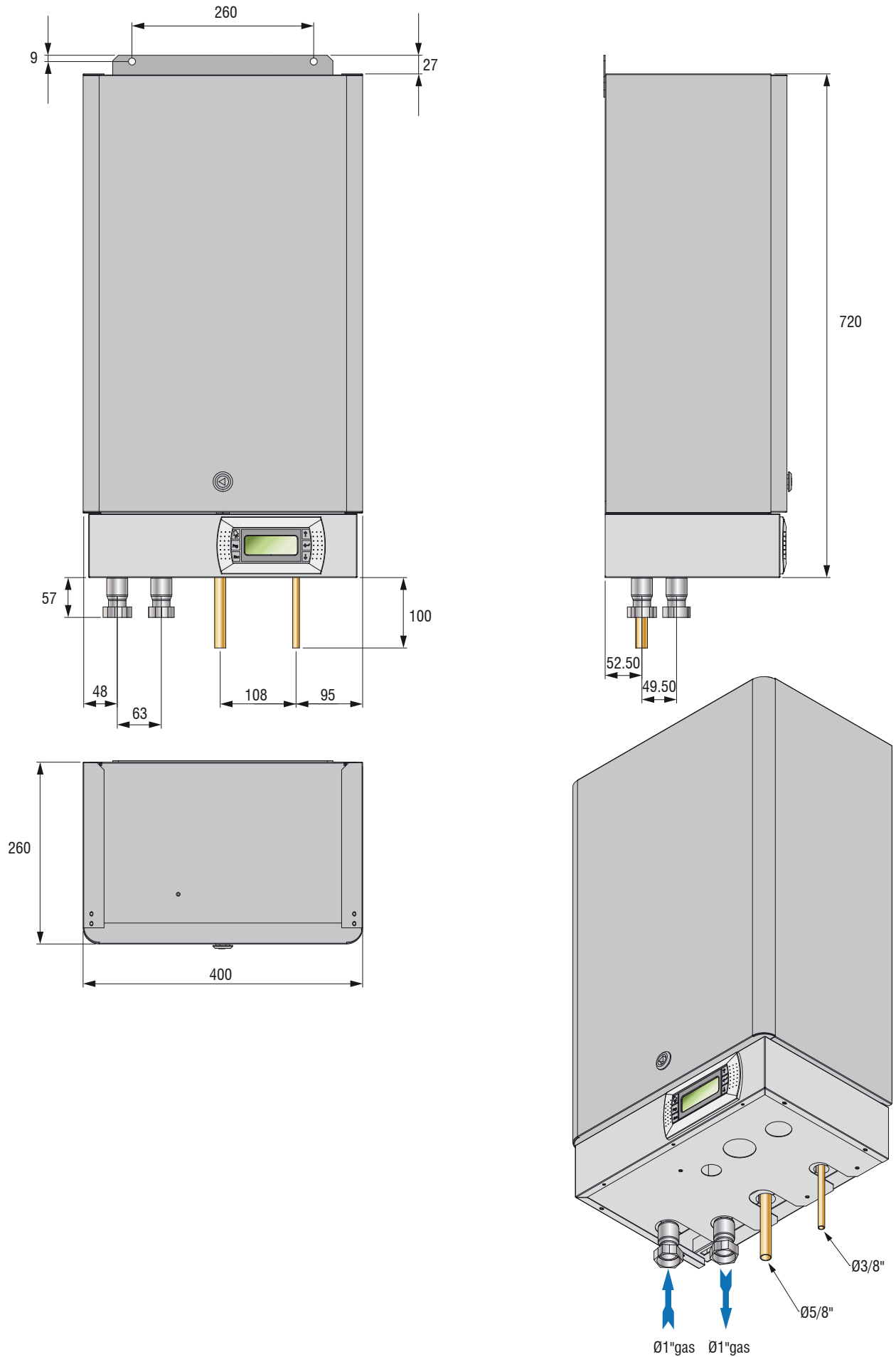

Minimum Clearances

Outdoor unit

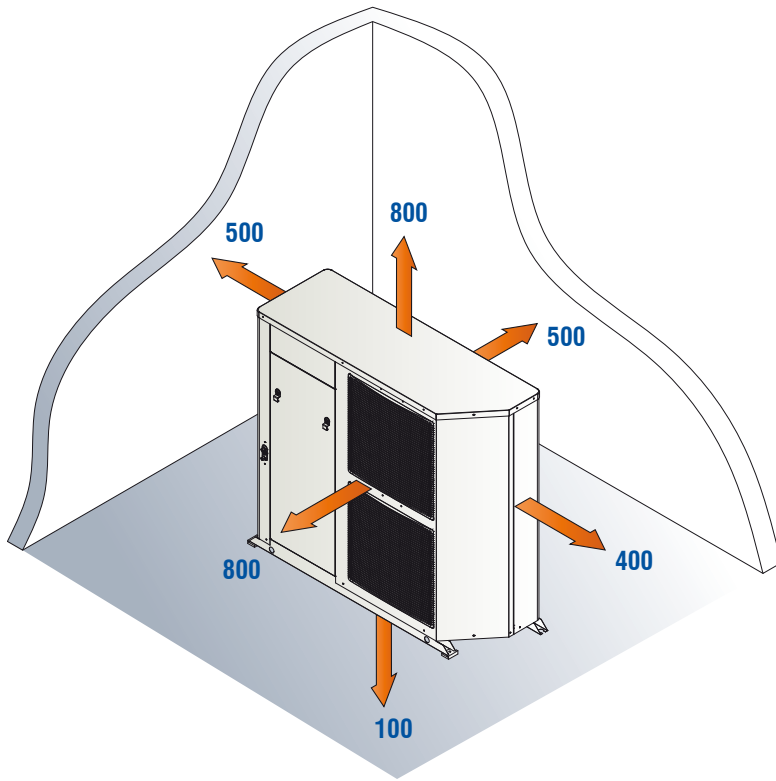

Indoor unit

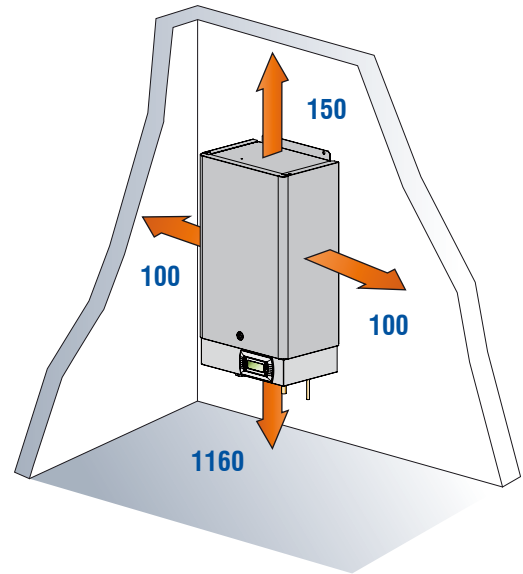

Domestic hot water tank (optional)

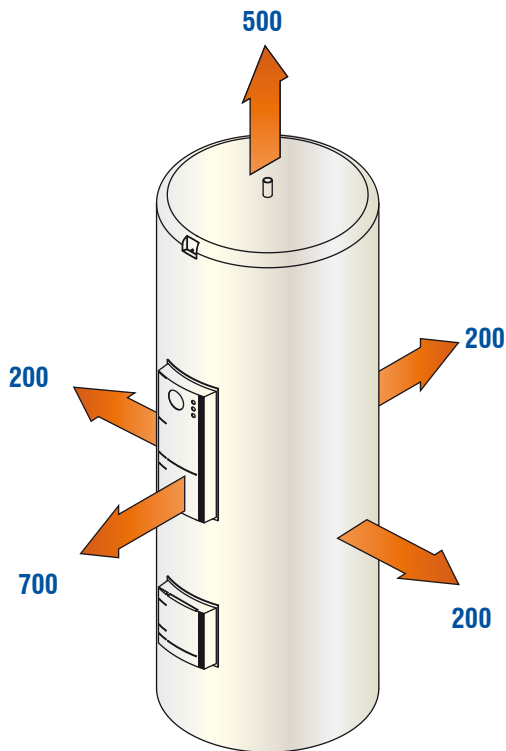

140 litre buffer tank (optional)

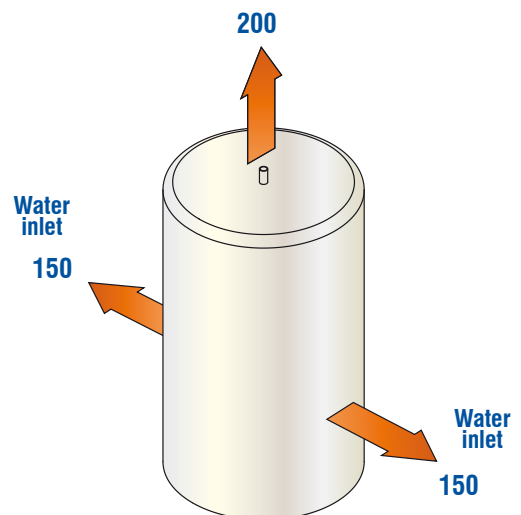

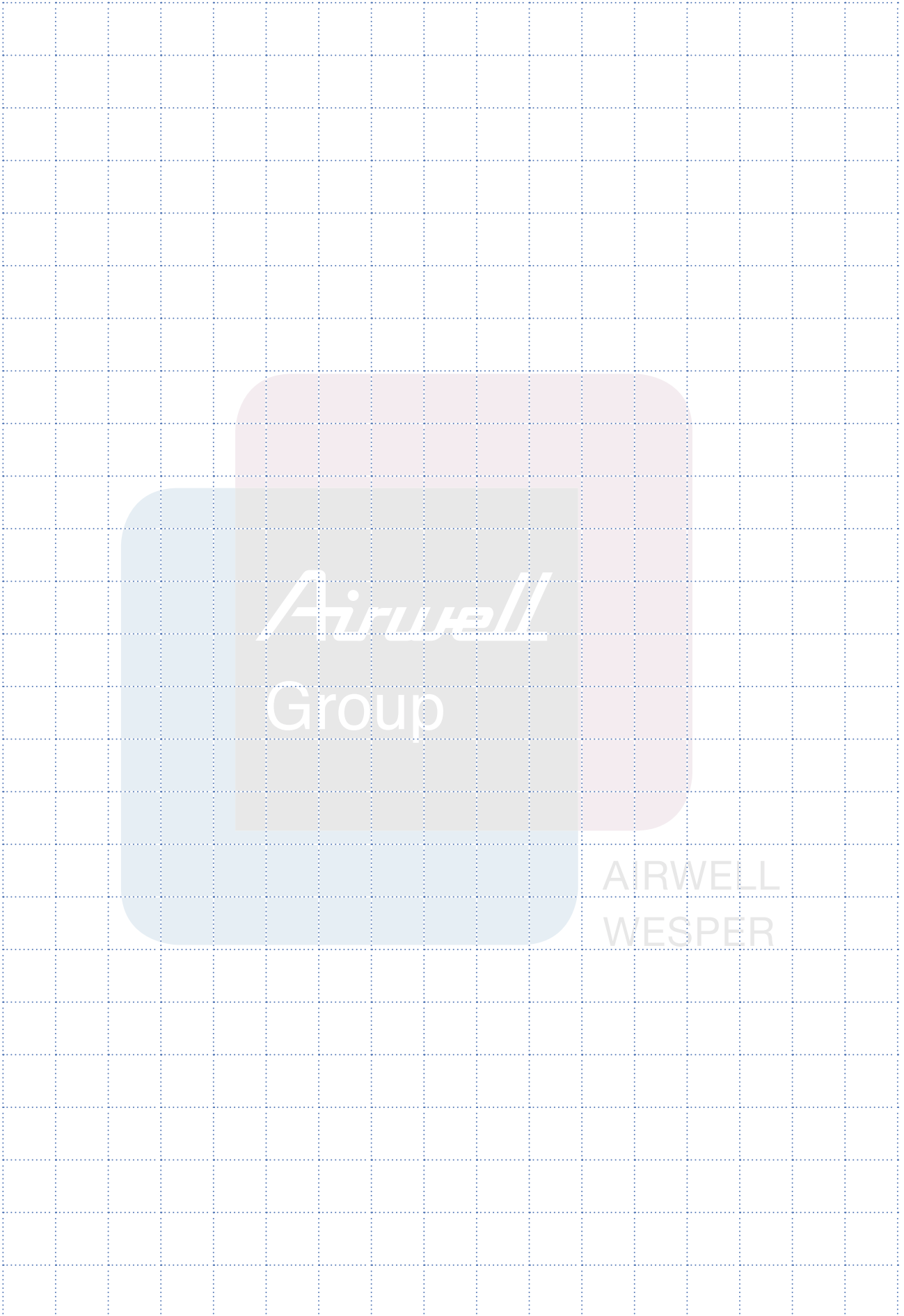

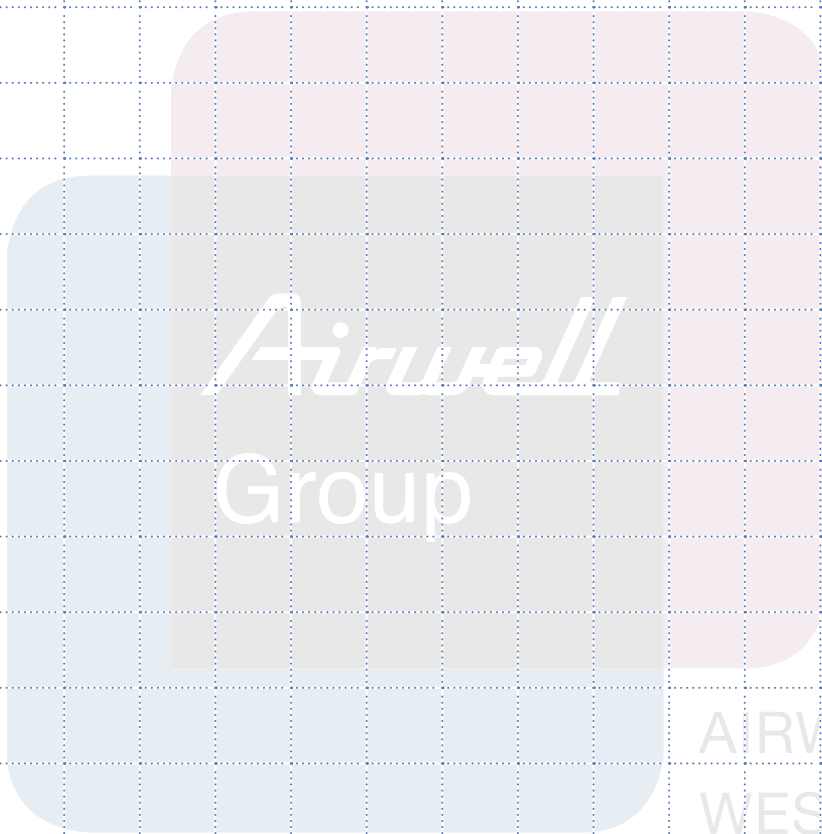

AIRWELL
WESPER

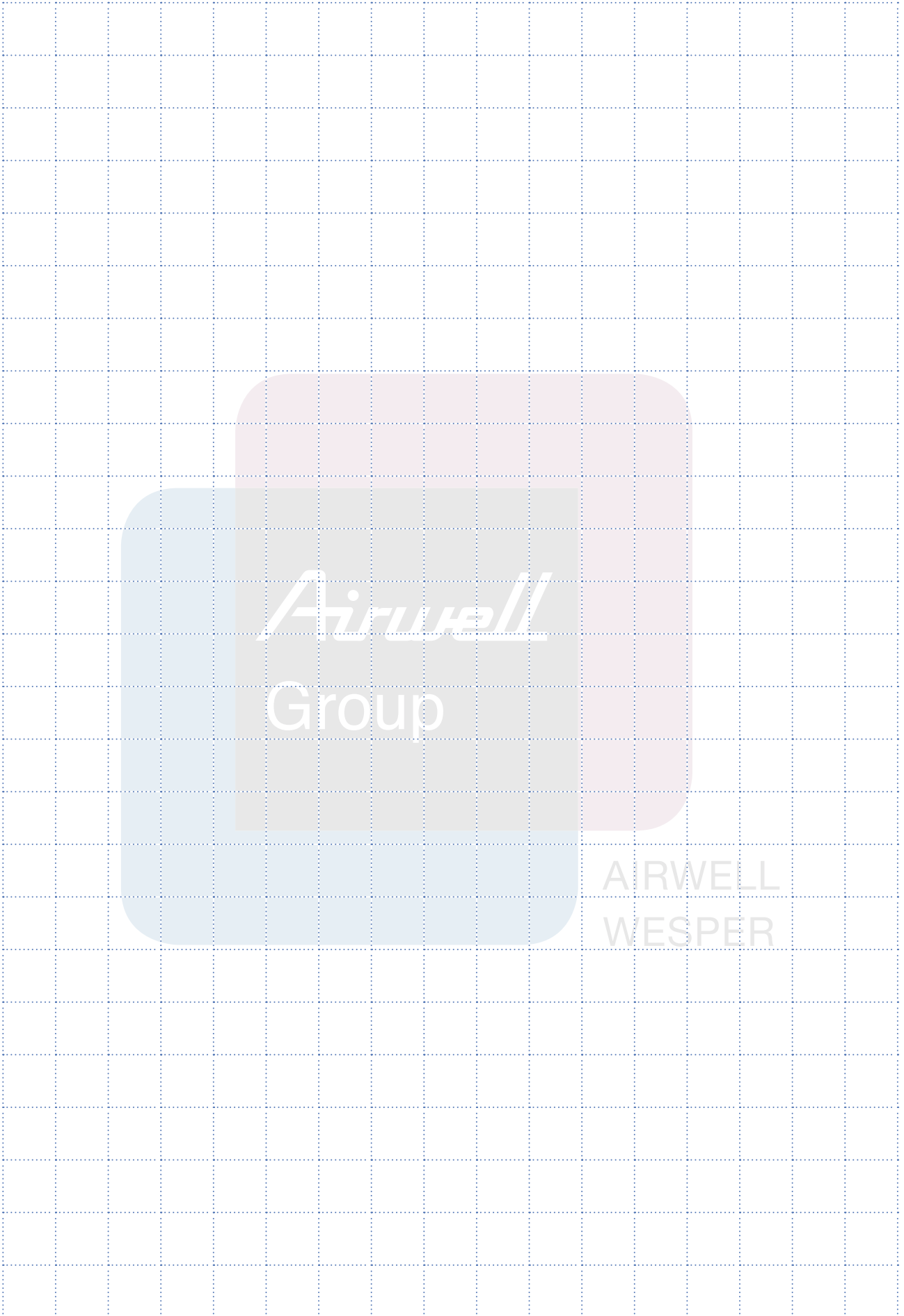



Airwell
by Airwell Group 

www.airwell.com

AIRWELL France SAS
1bis, Avenue du 8 mai 1945 - Saint Quentin en Yvelines
78284 GUYANCOURT - France
Tel. +33 (0)1 39 44 78 00
Fax +33 (0)1 39 44 65 17



AIRWELL
WESPER

Ref. : **EDM PACTH-A.3GB/12.12** - Supersedes : EDM PACTH-A.2GB/02.11

As part of our ongoing product improvement programme, the technical data and colours of our products are subject to change without prior notice. Non contractual photos.