



7^{1947 - 2017}
Airwell
years

Just feel well

2017/2018
Air conditioning



Contact Us

An international sales network

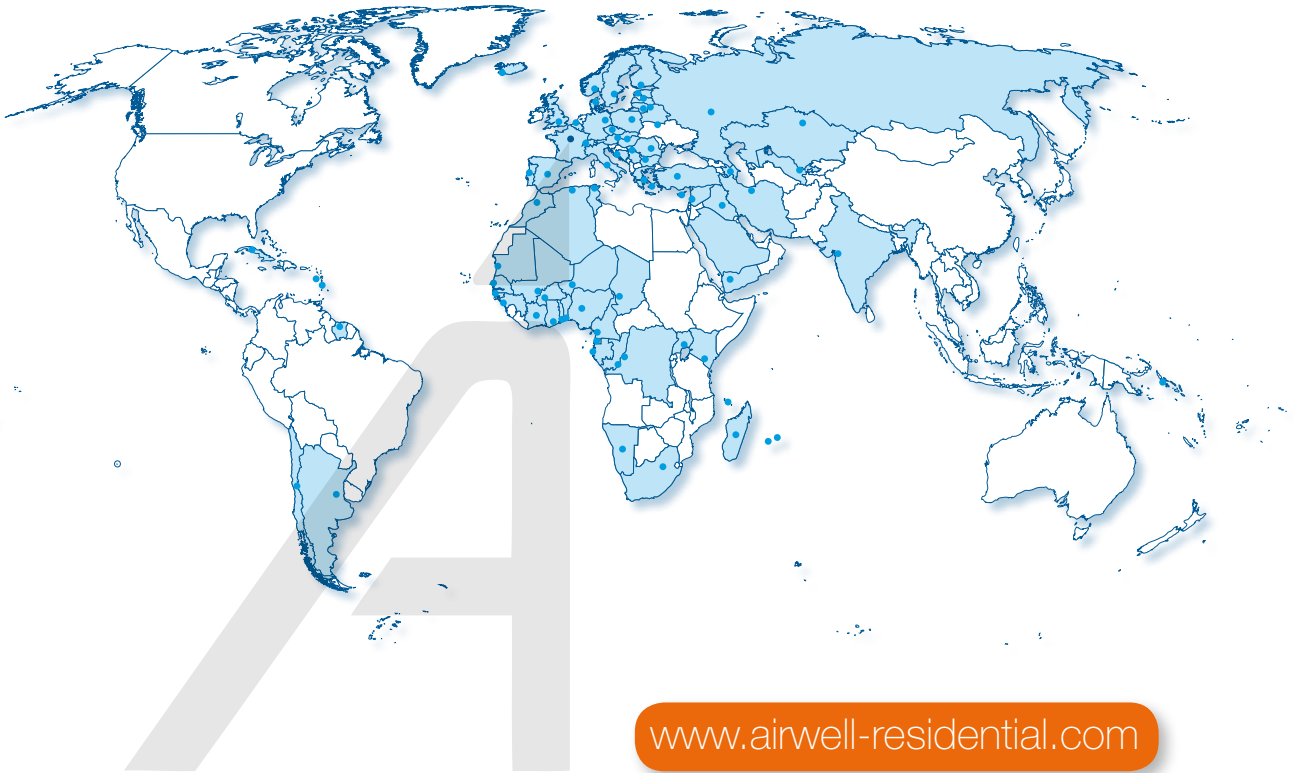

www.airwell-residential.com

Contact details

[HEADQUARTERS]

3, avenue du Centre - Les Quadrants - Bâtiment A
78280 Guyancourt - FRANCE

[DOCUMENT LIBRARY]

<http://lh.airwell-res.com>

[COMMERCIAL]







E-mail: airwell-residential@airwell-res.com
Tel: +33 (0)1 76 21 82 00

[AFTERSALES]

SPARE PARTS ORDERS E-mail: sp@airwell-res.com
TECHNICAL SUPPORT E-mail: technical-spfr@airwell-res.com
Tel: +33 (0)1 76 21 82 95
Monday to Friday: from 9:00 am to 12:30 pm
and from 2:00 to 5:00 pm



Table of contents

	PAGE
HISTORY	6
REGULATION AND STANDARDS	8
OUR UNIQUE SOLUTIONS	14
SERVICES DIVISION	24
HIGH WALL RANGE	30
HRD NEW High wall monosplit 	32
HND High wall mono & multisplit 	34
HKD High wall mono & multisplit 	36
DUCTED RANGE	38
DLF Ducted: Horizontal and vertical installation	40
DLSE+VAV Ducted with zone control	44
DID NEW Residential ducted unit 	52
DED NEW Light commercial ducted	56
CASSETTE RANGE	58
CCD NEW Cassette mono & multisplit 	60
FLOOR CEILING RANGE	64
XBD NEW Console dual flow mono & multisplit 	66
FCD NEW Floor ceiling monosplit	68
FWDB Floor ceiling monosplit for low temperature rooms	70
TWIN & MULTISPLIT RANGES	72
TWIN Twin system	74
YCZ UPGRADE Residential multisplit 	76

		PAGE
MONOBLOC & FLOOR STANDING RANGES		84
MAF	On/off portable	86
WFD	Window 	87
SBF	On/off floor standing	88
WATER RANGE		90
CAO	Water console	94
GCAO	Water source	96
LIGHT COMMERCIAL RANGE		98
X AC	Vertical air cabinet	100
X WC	Vertical water cabinet	102
HAN	Rooftop unit	104
VRF RANGE		106
Outdoor units:		106
Mini FlowLogic	Front Discharge 5 HP - 6 HP - 10 HP	112
FlowLogic III	NEW Top discharge 10-14-16-18-20-24 HP	114
Indoor units:		108
HBV	NEW High wall	124
CBV	Cassette 600x600	125
CCV	Cassette 900x900	126
FAV	Floor ceiling	127
DAV	UPGRADE Ducted low static pressure	128
DBV	Ducted medium static pressure	129
DCV	Ducted high static pressure	130
EAV	Console	131
AHU Connection kit		132
Central control solutions		136
ACCESSORIES		142
Installation accessories		142
Control systems UPGRADE		144
Airwell Sensibo		146
TOOL BOX		148
ICON GUIDE		152

History



- 1947 ■ The beginning of the Airwell's story, a french air conditioning brand.
- 1950 ■ The firm developed and began the mass production of the first window unit, to offer exceptional climate conditions, mainly dedicated to European and African markets.
- 1970 ■ Airwell developed a split system unit by splitting its core window unit in two parts. It was the first to produce wall split systems in Europe. Implantation of historical plant Tillières-sur-Avre in France.
- 1982 ■ The company designed and produced the first European wall split system range including electronic remote control, a high technology cross-flow fan for low noise levels and rotary compressors.
- 1998 ■ The group acquired production facilities in China (Shenzhen).
- 2013 ■ The firm launched its unique and exclusive call center dedicated also to final customer.
- 2014 ■ Airwell set up presentation and training center in France and worldwide.
- 2015 ■ Airwell launched its new online order service.
- 2017 ■ Airwell celebrates its 70th anniversary.

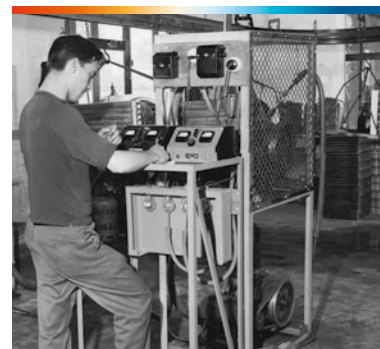

Regulation and standards



An important part of Airwell's strategy is to anticipate and go further beyond the new European regulations, safety standard and guidelines that will be applied soon.

The requirements are covering all the cycles of the production process from manufacturing to distribution and marketing.

Most of the Energy requirements today are related to the European Commission Plan named "20-20-20" to improve the environmental aspects of Energy related product, which dictate the following:

- Reduce by 20% the emissions of greenhouse gases.
- Increase by 20% the energy efficiency of energy systems in the EU..
- Reach 20% of renewables in total energy consumption in the EU.

Due to its international presence, Airwell Residential must comply with the most drastic regulations and standards related to the product's manufacturing, safety, energy and design.

Airwell products are designed as environmental friendly and safe.



The most important regulations today are:



Since January 2015, the regulation FGAS (EU 517/2014) is implemented.

Refrigerant fluid are man-made gases that can remain in the atmosphere for centuries and contribute to a global greenhouse effect. There are three types: hydrofluorocarbons (HFCs), perfluorocarbons (PFCs) and sulphur hexafluoride (SF6).

The F-Gas regulation's goal initiated by the European commission is to reduce greenhouse gas emissions in the EU by 80-95 % compared to levels in 1990.

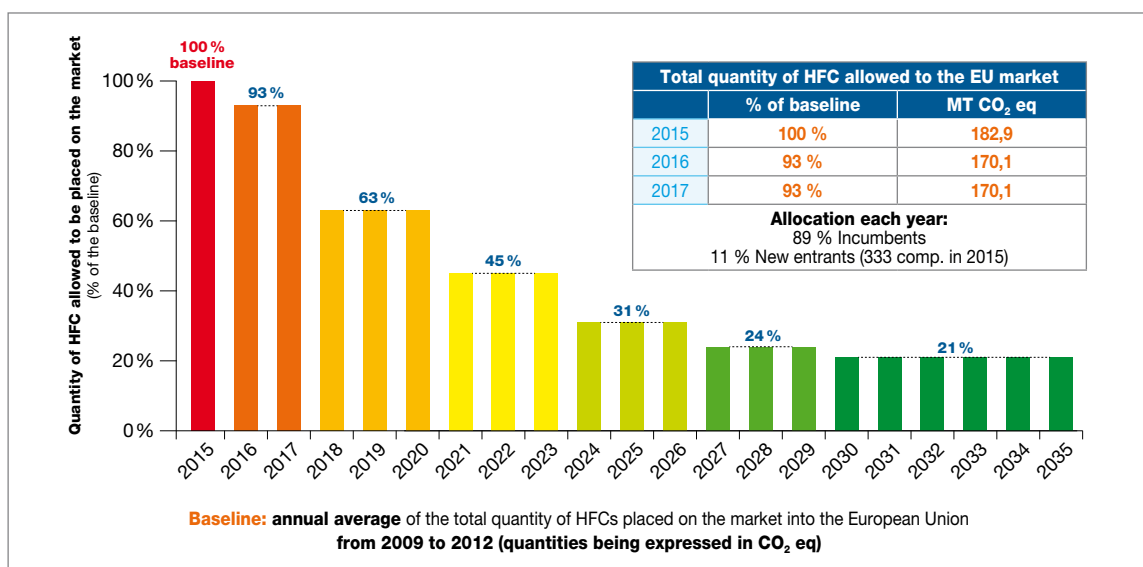

Energy Label design

HOW THE ENERGY LABEL IS IMPLEMENTED?

Rated power (P_{design} H/C) and SEER/SCOP test condition:

- Each model is rated at rated power in cooling and heating:
 - **For cooling:** P_{design}C.
 - **For heating:** P_{design}H.
- Each product must meet the climate requirement levels to which it belongs:
 - **Average:** minimum condition to fulfil.
 - **Warmer:** if the product is designed for warmer conditions.
 - **Colder:** if the product is designed for colder conditions.
- P_{design} affects directly the SEER/SCOP level as there are few tests done in cooling and heating according to the climate category and adjusting the power for each test condition.
- The below table shows the test conditions in cooling and heating, the ratio of the P_{design} in cooling and heating in a different climate category.

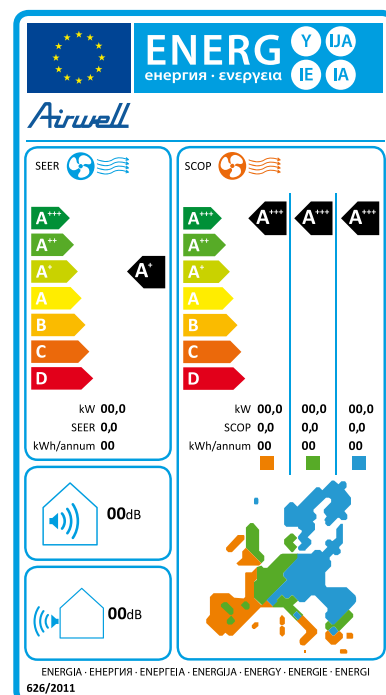

Operating conditions for standard rating

	New standard (ECO design)								
	Indoor unit		Outdoor unit						
	Air inlet °C		Test type	Air inlet °C					
	Dry bulb temperature	Wet bulb temperature		Inlet temperature			Part load of Pdesign ratio		
Cooling mode	27	19	A	35			100%		
			B	30			74%		
			C	25			47%		
			D	20			21%		
Heating mode	Indoor unit		Test type	Class category					
	Air inlet °C			Average		Warmer		Colder	
	20	15 max	T _{design}	-10	100%	2	100%	-22	100%
			A	-7	88%	-7	N/A	-7	61%
			B	2	54%	2	100%	2	37%
			C	7	35%	7	64%	7	24%
			D	12	15%	12	29%	12	11%
T _{bivalent}	The design condition of the A/C can provide the optimized power w/o any additional energy like heater								
T _o (Min operating temperature)	-15	119%	-15	N/A	-15	82%			

Factory certifications



Airwell Residential is recognized for its reliability. A residential and light commercial range of products with an excellent quality which offers their clients a very big advantage on the air conditioning market. Present all over the world, Airwell Residential applies quality standards to its different production sites and strives to improve them continuously.

The performances of our Airwell Residential products meet the EN14825 standard (seasonal energy standard).

Airwell Residential production sites are certified ISO 9001 and ISO 14001 as well as by most of the recognized certifications.

CE marking

« CE marking » was introduced pursuant to European technical harmonization legislation. It is mandatory for all products covered by one or more European directives which expressly provide for it and it guarantees free movement throughout the EU for these products.

Airwell conduct controls and tests ensuring that our products comply with essential requirements, particularly those concerning health and safety, as set forth in the relevant directives.

Eurovent



Airwell Residential contributes to the Eurovent certification program.

Eurovent Certification certifies the performance ratings of its range (Splits and Multi Splits with at least two indoor units) according to European and international standards. The common competitive playing field for all manufacturers allows to increase the integrity and accuracy of the industrial performance ratings.

Only products listed on Eurovent website are certified. You can check it on:
www.eurovent-certification.com

PEP - Ecopassport®



Airwell is part of an eco-environmental approach including a life cycle analysis of our products while building a Product Environmental Profile (PEP).

This life cycle analysis (LCA) allowed to inventory and quantify, all along the products lifecycle, the physical material and energy flow associated to human activities. All the lifecycle phasis have been taken into account: raw materials, manufacturing, transport, distribution, usage, end of life and recycling.

The PEP fits the ISO 14025, 14040 and 14044 expectations. It allows to anticipate the regulatory obligations and forms part of the eco-conception approach which Airwell wants to follow. Finally, building a POP allowed to calculate the environmental performance of some products.

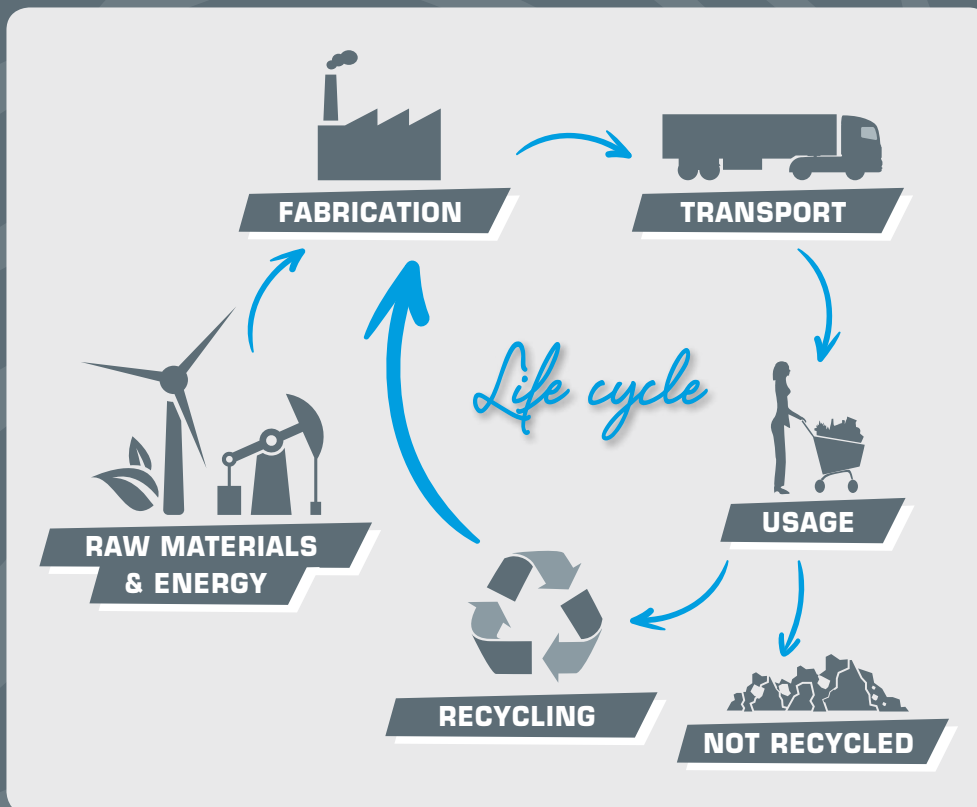



Our unique
solutions



DISCOVER OUR UNIQUE SOLUTIONS

Well-being

- 2 WiFi solutions
- Super quiet
- Presence detector option

Cost saving

- High efficiency
- DC Inverter technology 3D-4D

Well designed

- New outdoor unit concept
- Improvement of communication wire connection
- Check running parameters by remote controller
- Automatic refrigerant leakage detection



AND OUR UNIQUE APPLICATIONS

- Refrigerant R32 environmental friendly
- DLSE Plus VAV ducted unit
- DLF ducted unit
- CAO and GCAO: water solution

Air.Net



Control your A/C from anywhere at any time

Air conditioners controlled by mobile phone, tablet or computer with wireless router and internet.



- Easy installation.
- Control your A/C by mobile phone/tablet locally or from distance.
- Can control: on-off, operation mode, fan speed, temperature set-up and timer.
- Aesthetic hidden display.
- Android and IOS compatibility.
- HRD/HND/HKD lines: optional.

CONTROL ALL HOME'S AIR CONDITIONERS AIRWELL



Airwell Sensibo



Airwell Sensibo is a controlling system that manages remote operation of your air conditioning, whatever the brand of your air conditioner, technology (Fixed speed or Inverter) or gas used (R22, R407C, R410A...). The system is easy to install and operate.

- Works on all type of A/C which operates with infrared remote controller.
- Easy installation with no wires to the unit.
- Can be transferred from one A/C to another.
- “Plug & Play” system composed by a hub and up to 10 pods to control your air conditioning.

CONFIGURATION

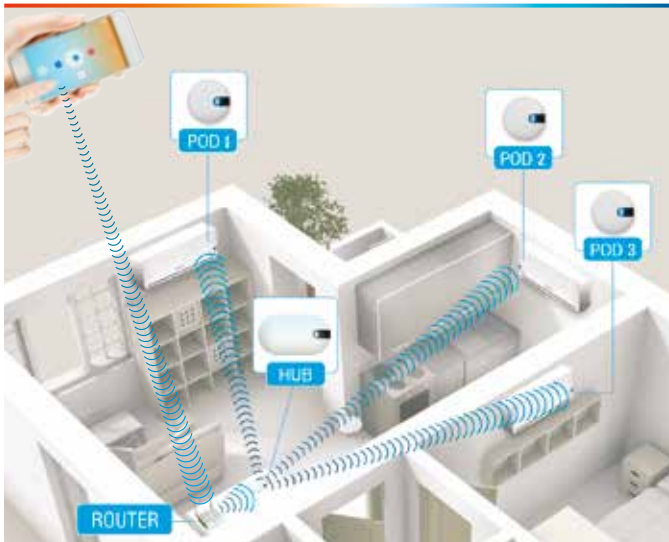

MAIN FEATURES

- Cools or heats your home before you arrive
- Weekly timer to save energy
- Optimizes temperature and humidity levels
- Saves energy and reduces your electricity bill
- Lets you control the A/C from anywhere



OUR WIFI SOLUTIONS

FUNCTIONS	AIR NET SOLUTION - OPTIONAL	AIRWELL SENSIBO SOLUTION
	On-off, Operation mode, Fan speed, Temperature set-up, Timer	On-off, Operation mode, Temperature set-up, Fan speed, Timer, Weekly timer
High wall HRD	●	●
High wall HND	●	●
High wall HKD	●	●
Ducted DLF		●
Ducted DLSE		●
Ducted DID		●
Cassette CCD		●
Console XBD		●
Floor Ceiling FCD		●
Portable MAF		●
Window WFD		●
Floor standing SBF		●

Unique solutions

Super quiet

SUPER QUIET:

- Good-neighbourly relations
- - 4 dB(A)

→ Special design for low noise level.

→ Optimized solution suitable for bedrooms.



Presence detector option

→ Efficient solution to save money and optimize regulation is installing presence detector solution via Airwell dry contact.

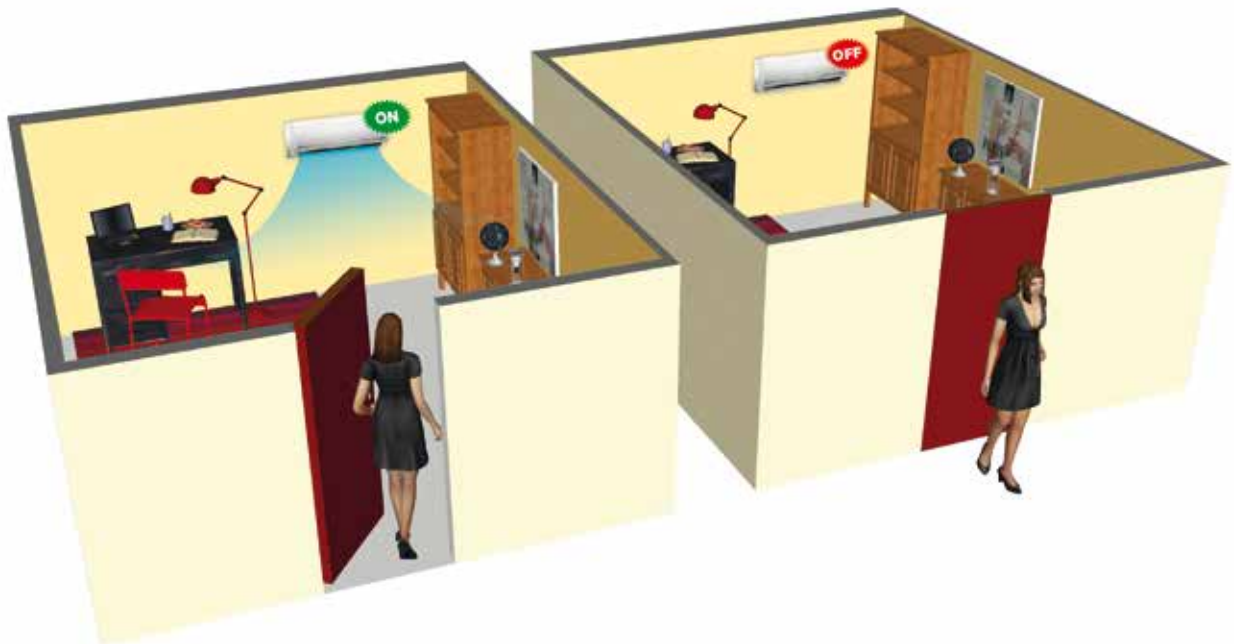

High efficiency

- Reduce your environmental footprint.
- Reduce annual energy consumption in cooling and heating mode and save money!



DC Inverter technology 3D-4D

- System design based on DC motors.
- DC motor contributes directly to the system efficiency.
- 4D design based on DC indoor motor, DC outdoor fan motor, DC inverter compressor and Electronic expansion valve.
- In 4D the system can work with optimized parameters in order to achieve maximum performance and comfort.

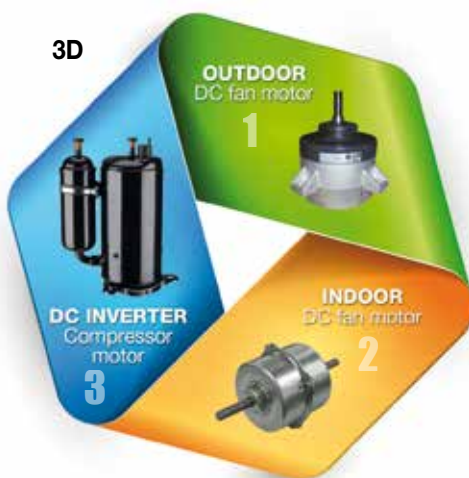

Technology used for:
HND/HKD

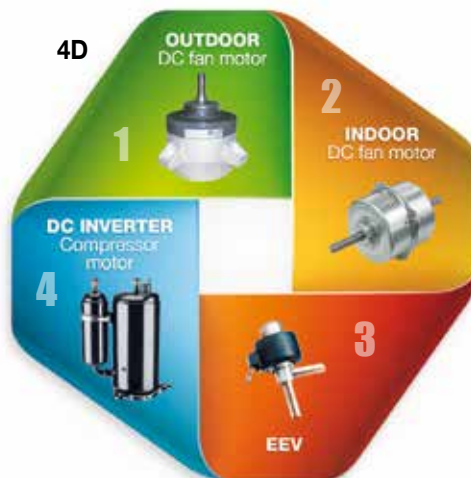

Technology used for:
HRD/XBD/CCD/PCD/DID

New outdoor unit concept



New electronic card concept:

- Upside-down design
- 70% dust reduction
- Higher reliability

New designed mounting:

- Rigid design
- Easy installation and maintenance
- Time saving

New performances:

- Heating capacity until -15°C
- Lower noise level

Improvement of communication wire connection

→ Only two connection wires and without polarity, which can hardly avoid mistakes



Check running parameters by remote controller

- All below parameters can be showed on display of indoor unit through a remote controller: sensors, compressor, EEV informations, error codes, outdoor and indoor units status.
- Simple and fast for maintenance.

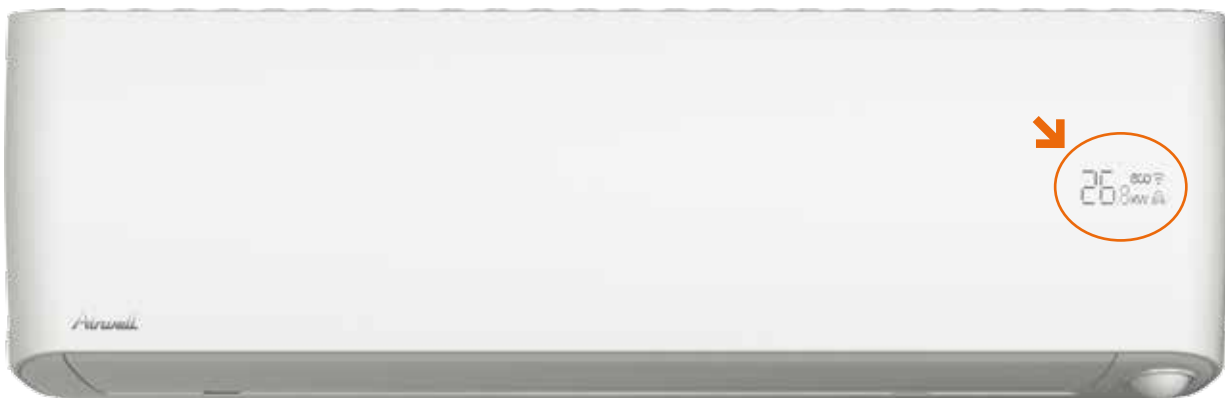

Automatic refrigerant leakage detection

- The electronic controller checks continuously the system parameters and identifies the presence of a refrigerant leakage. In a case of leakage, the system stops, protects the compressor from damage and avoids major service costs.

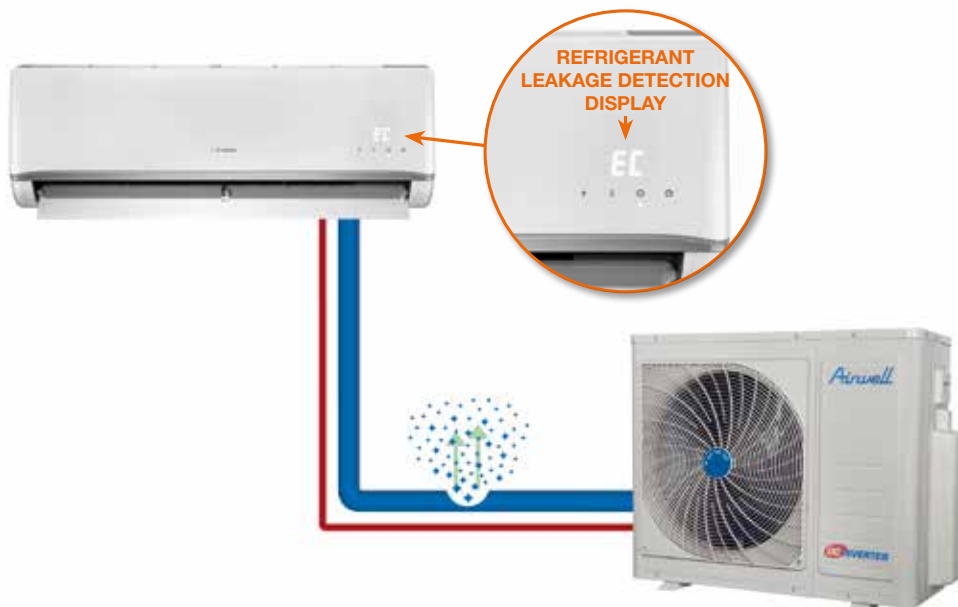

Refrigerant R32 environmental friendly

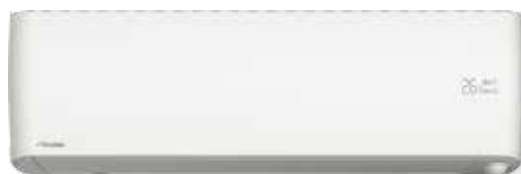

HRD



WFD

GWP COMPARISON BETWEEN COMMON FLUID				
Refrigerant fluid	R134a	R407C	R410A	R32
GWP (Global Warming Potential)	1430	1774	2087	675

→ Global Warming Potential (GWP) is a relative measure of how much heat a greenhouse gas traps in the atmosphere.

More details: HRD High wall p. 32 - WFD Window p. 87

DLSE Plus VAV ducted unit

- Intelligent air conditioning: Controls up to 6 rooms
- Cost & energy saving
- DC motor combined with horizontal fan creating high efficiency
- Advanced logic to control the Inverter compressor



More details p. 44

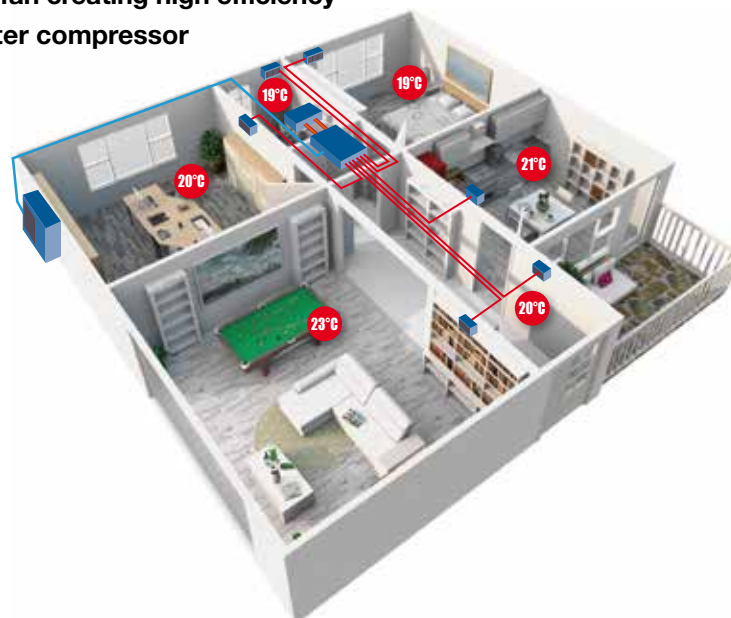

DLF ducted unit



- Vertical and horizontal installation
- Compact: 200 mm height, space saving
- Super quiet
- Hidden solution

More details p. 40



CAO and GCAO: water solution



- Ideal solution for building with aesthetic and local restrictions
- Easy & simple installation

More details p. 92

Unique applications

Services division

The training solution for installers

Training courses 

In partnership with its customers, Airwell Residential provides you with Airwell Academy centers for presentations and training, both in France and worldwide. Training courses are regularly offered to present the brand's product range and unique solutions. New centers are due to open throughout the year.



For all training requests, please contact us at the following e-mail address:

■ airwell-academie@airwell-res.com





Training plan



Air conditioning

- Residential air conditioning
- Light commercial air conditioning
- Air conditioning systems regulation



Heating

- Residential heating
- Light commercial heating
- Heating systems regulation



Statutory trainings

- Solutions for hospitals
- Solutions for hotels
- Residential solutions
- Anti-legionellosis solutions
- Water treatment



Sales training



Energy performance

- Design offices
- Installers
- Architects

Read more on our website:

■ www.airwell-residential.com

Pre-sales

Airwell Residential supports you throughout your projects (housing units, hotels, shops, industrial sites, etc.).

Before your plans are implemented, the pre-sales department studies your residential or industrial project to recommend the best technical solution.

Using selection software, the pre-sales selects and designs your air conditioning system.

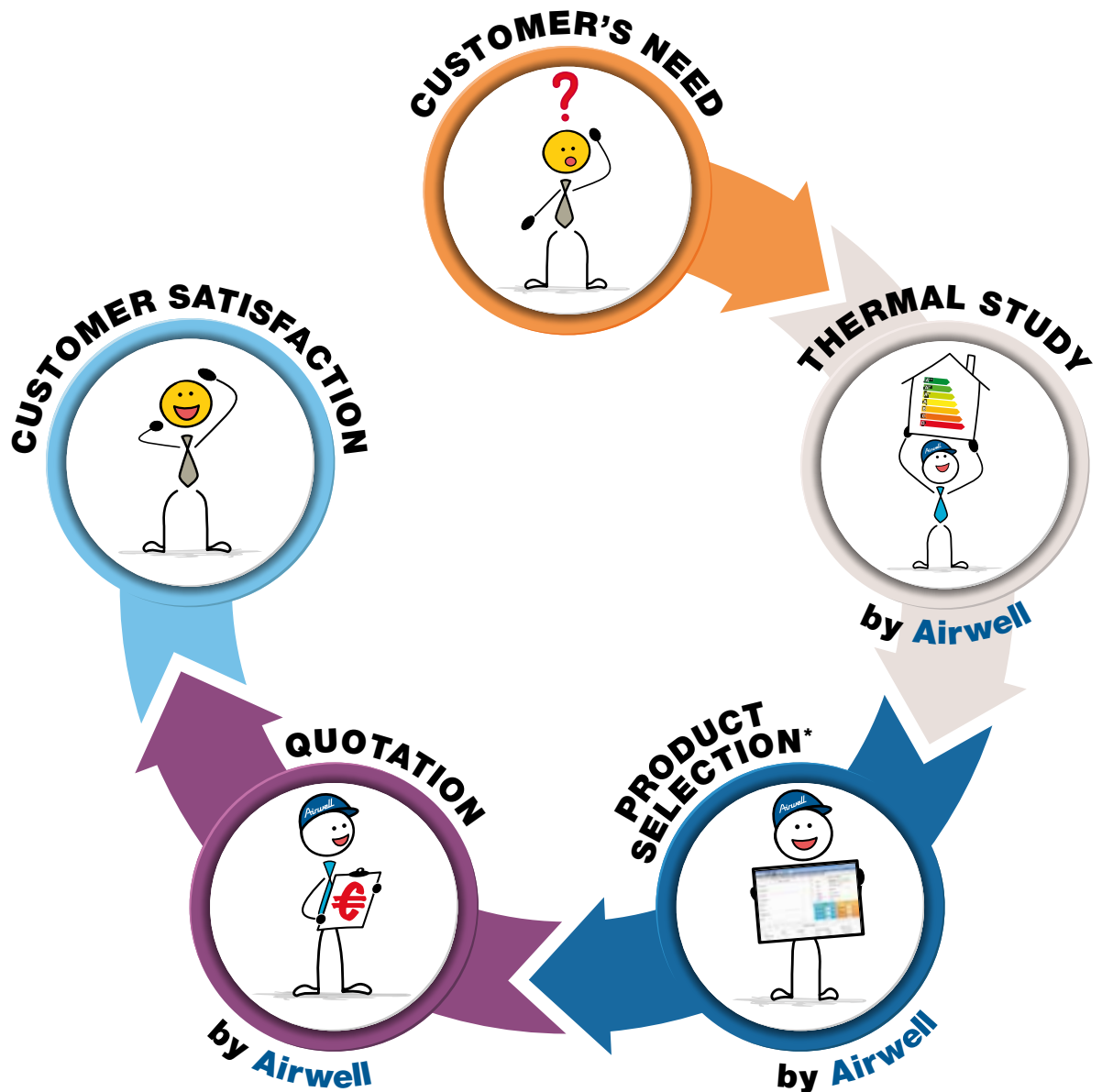

* and installation dimensioning

Installation/Commissioning

CALL CENTER

- Quick, useful response from our experts
- Generous availability
- Multilingual call center
- Professionals who constantly benefit from training
- A customer-based, service-orientated approach!
- As much attention and help as required for the customer to be fully satisfied



LOCAL AND REMOTE TECHNICAL SERVICE (worldwide)

- Specialized and experienced technicians
- Direct contact by telephone; on-site contact for VIP customers if required
- Full products training
- Supervision of work (field monitoring)
- Commissioning by Airwell Approved Technical Station

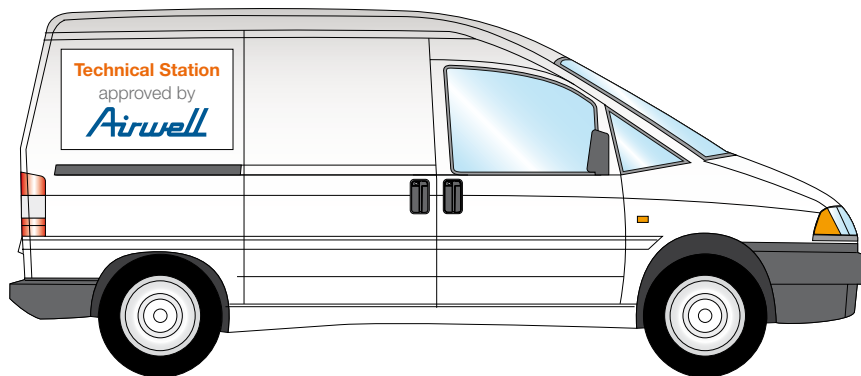

SPARE PARTS SERVICE

- Global warehouse in France



Tel. ■ +33 (0)1 76 21 82 95

SPARE PARTS ORDERS:
e-mail ■ sp@airwell-res.com

TECHNICAL SUPPORT:
e-mail ■ technical-spfr@airwell-res.com

Online order service

Airwell Residential offers you a new online order service for spare parts and finished goods on the website: **www.airwell-residential.com**

Create your account easily!

- Fill out the request form (download it on our website) and send it to your area sales manager.
- You will receive by mail your login and password to order your products.

Connect to **www.airwell-residential.com** to the « Order online » service using your personal login.

■ SPARE PARTS ORDER

1. Select the module « Spare part order »



2. Access to spare parts catalogue online



3. You are redirected to the catalogue which allows you to search your device in different ways:

- By serial number
- By goods number
- By description (partial search)

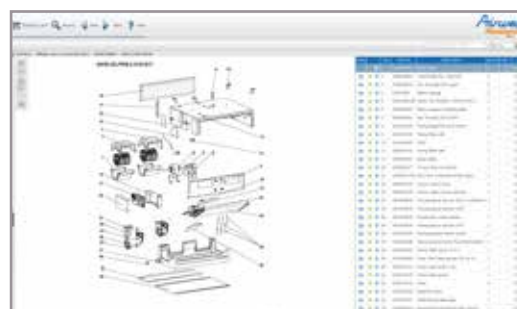

4. Select your spare parts in the exploded view

5. Order summary with your net prices and spare parts availability. Please indicate your part number and a delivery

				Public price	Discount price
+	E124296	ICHD chip for fan motor	Motor Range	4,2K HT	1,50K HT
+	88818903	Pump P18-12/1/1/2	Pump P18-12/1/1/2	135,79K HT	84,32K HT
+	1048814				
SUBTOTAL				136,00K HT	86K HT

6. Finalize your order. You must click in the link sent by email to confirm your order.

				Public price	Discount price
+	C334296	ICHD chip for fan motor	Motor Range	4,2K HT	1,50K HT
+	88818903	Pump P18-12/1/1/2	Pump P18-12/1/1/2	135,79K HT	84,32K HT
SUBTOTAL				138,00K HT	86K HT
Shipping fees					0K
TOTAL				138,00K HT	86K HT

An email containing a confirmation link has been sent.
You must click the link to confirm the order close to Airwell Residential Team.

FINISHED GOODS ORDER

1. Select the module « Finished goods order »
2. Indicate in the search engine your part number product (code, product name)

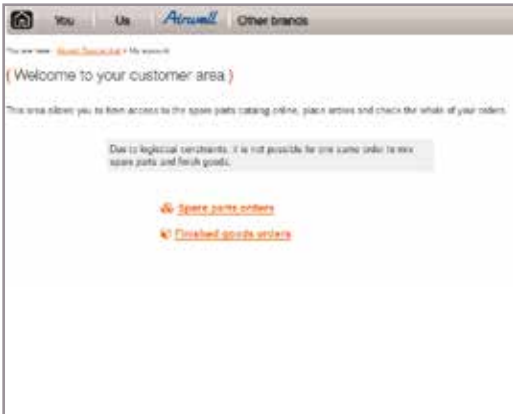





3. Add products to your shopping cart.
4. Order summary with your net prices and products availability. Indicate your part number and a delivery address.



5. Finalize your order. You must click in the link sent by email to confirm your order.

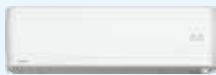

High wall Range

【 MODEL NAME 】	Page
HIGH WALL MONOSPLIT	NEW
	HRD
	32
HIGH WALL MONOSPLIT & MULTISPLIT	
HND	
34	
HIGH WALL MONOSPLIT & MULTISPLIT	
HKD	
36	

7
2 kW

9
2.5 kW

12
3.5 kW

18
5 kW

24
7 kW





NEW **A+++**

+ PRODUCTS

- Refrigerant R32 environmental friendly.
- Designed for extreme climates.
- WiFi option.



RC08C

FEATURES

FLEXY MATCH	1 W STANDBY POWER	R32 FLUID	ELECTRONIC EXPANSION VALVE
REFRIGERANT LEAKAGE DETECT	NANO PHOTOCATALYTIC FILTER	AUTO CLEAN/DRY	WIDE ANGLE LOUVER
SLEEP MODE	SUPER QUIET	HOT KEEP	DIGITAL DISPLAY
TURBO MODE	PROGRAMMABLE TIMER	SELF DIAGNOSTIC	LOW BATTERY INDICATION
AUTO RESTART (MEMORY)	REMOTE CONTROL LOCK	AUTO MODE OPERATION	AUTO FAN
8°C CONSTANT TEMPERATURE HEATING	INDOOR MULTI FAN SPEED	LEFT/RIGHT DRAIN CONNECTION	OUTDOOR BASE HEATER
CRANKCASE HEATER	LOW AMBIENT COOLING	LOW AMBIENT HEATING	SERVICE MONITOR TOOL
WIFI			

- Operating down to -30°C in heating mode.
- “I Feel” function with precise room temperature control.
- Multifan speed in indoor unit.
- “Follow Me” function.



“FOLLOW ME” FUNCTION



Wind flow away from people



Wind flow follow people



Strong wind when more people in room



Gentle wind flow when less people in room

OPTIONS

Accessory	Part number	Photo	Function
Test tool for high wall	7ACEL1710		Easy viewing of system parameters, failure records and parameter adjustments.
Air Net WiFi Module	7ACEL1719		Control air conditioners with your mobile phone, tablet or computer with wireless router and internet.



HRD TECHNICAL DATA

Indoor units		AWSI-HRD009-N91	AWSI-HRD012-N91
Outdoor units		AWAU-YRD009-H91	AWAU-YRD012-H91
COOLING			
Rated power	kW	2.65 (1.0-4.7)	3.54 (1.3-4.8)
Pdesignc	kW	2.65	3.54
Rated power input	kW	0.489	0.802
SEER/Energy label		9.3/A+++	8.5/A+++
Operating limits	°C	-15°/50° Dry bulb	
HEATING			
Rated power	kW	4.1 (0.9-5.2)	4.3 (1.0-6.3)
Pdesignh (average climate)	kW	2.3	2.5
Pdesignh (warmer climate)	kW	3	3.1
Pdesignh (colder climate)	kW	3.6	3.8
Rated power input	kW	0.870	1.020
SCOP/Energy Label (average climate)		5.1/A+++	5.1/A+++
SCOP/Energy Label (warmer climate)		6.1/A+++	6.1/A+++
SCOP/Energy Label (colder climate)		4.0/A+	3.4/A
Operating limits	°C	-30°/30° Dry bulb	
Power @ -10°C	kW	3.40	3.40
Power @ -15°C	kW	3.10	3.10
INDOOR UNIT			
Sound pressure level to 1 m (VL/LS/MS/HS)	dB (A)	20/23/28/32	20/24/29/33
Sound power level	dB (A)	59	59
Airflow (VL/LS/MS/HS)	m³/h	270/360/450/540/640	270/360/450/540/640
Dehumidification	l/h	1.0	1.2
Outline dimensions (WxHxD)	mm	800x554x333	800x554x333
Package dimensions (WxHxD)	mm	975x325x370	975x325x370
Net weight/Gross weight	kg	13/16	13/16
Part number		7SP023060	7SP023061
OUTDOOR UNIT			
Sound pressure level to 1 m	dB (A)	51	51
Sound power level	dB (A)	57	57
Airflow	m³/h	1980	1980
Compressor type		Rotary DC Inverter	Rotary DC Inverter
Outline dimensions (WxHxD)	mm	800x554x333	800x554x333
Package dimensions (WxHxD)	mm	920x615x390	920x615x390
Net weight/Gross weight	kg	37.8/40.5	37.8/40.5
Part number		7SP062915	7SP062916
POWER SUPPLY 1~230V - 50 HZ			
Power supply side		Outdoor	Outdoor
Power cable section	mm²	3x1.5	3x1.5
Fuse rating am	A	10	10
Electrical connections	mm²	5x1.5	5x1.5
PIPE LINE			
Suction pipe diameter	inches	3/8"	3/8"
Liquid pipe diameter	inches	1/4"	1/4"
Max. length	m	25	25
Max. height	m	10	10

COMBINATIONS

Indoor unit	Compatible with outdoor unit
High wall	Monosplit
HRD	YRD
	



+ PRODUCTS

- Full air quality solution.
- Wifi option.
- Super quiet.
- 2 airflow direction control.



FEATURES



- Operating down to -15°C in cooling and heating mode.
- "I Feel" function with precise room temperature control.
- Same indoor unit for multi and single applications (except size 7).
- Multifan speed in indoor unit.
- Refrigerant leakage detection alarm system.



FILTRATION AND PURIFICATION AIR





Full air quality solution includes multi-layer filters, electrostatic filter, photocatalytic and anti-bacterial filters as standard.

OPTIONS

Accessory	Part number	Photo	Function
Wired single control RCW8	7ACEL1706		Mode, fan speed, timer ON/OFF, temperature, swing and "I Feel".
Test tool for high wall	7ACEL1710		Easy viewing of system parameters, failure records and parameter adjustments.
ON-OFF dry contact adaptor	7ACEL1190		Remote control based on last memorized operation. Easy to connect with a weekly timer and window contact.
Air Net WiFi Module	7ACEL1719		Control air conditioners with your mobile phone, tablet or computer with wireless router and internet.



HND TECHNICAL DATA		ONLY MULTI CONFIGURATION				
Indoor units		AWSI-HND007-N11	AWSI-HND009-N11	AWSI-HND012-N11	AWSI-HND018-N11	AWSI-HND024-N11
Outdoor units			AWAU-YND009-H11	AWAU-YND012-H11	AWAU-YND018-H11	AWAU-YND024-H11
COOLING						
Rated power	kW	2.05 (1.0-2.7)	2.65 (1.2-3.3)	3.54 (1.3-4.4)	5.3 (1.8-6.1)	7.05 (2.7-7.8)
Pdesignc	kW		2.65	3.54	5.3	7.05
Rated power input	kW		0.66	1.095	1.64	2.181
SEER/Energy label			7.3/A++	7.3/A++	6.5/A++	7.0/A++
Operating limits	°C		-15°/50° Dry bulb			
HEATING						
Rated power	kW	2.34 (0.85-3.0)	2.8 (0.85-3.7)	3.7 (1.2-4.8)	5.5 (1.4-6.7)	7.3 (1.6-8.7)
Pdesignh (average climate)	kW		2.6	2.8	4.4	5.7
Pdesignh (warmer climate)	kW		2.8	3.2	4.6	7.1
Pdesignh (colder climate)	kW		2.8	3.5	5.3	8.0
Rated power input	kW		0.7	0.88	1.48	1.97
SCOP/Energy label (average climate)			4/A+	4.4/A+	4.2/A+	4/A+
SCOP/Energy label (warmer climate)			5.5/A+++	5.5/A+++	5.1/A+++	5.1/A+++
SCOP/Energy label (colder climate)			3.5/A	3.5/A	3.3/B	3.3/B
Operating limits	°C		-15°/30° Dry bulb			
Power @ -10°C	kW		2.8	3.0	4.2	6.2
Power @ -15°C	kW		2.5	2.6	3.9	5.5
INDOOR UNIT						
Sound pressure level to 1 m (VL/LS/MS/HS)	dB(A)	21/25/31/35	21/25/31/35	21/26/32/36	23/30/36/42	28/34/41/46
Sound power level	dB(A)	53	53	53	62	64
Airflow (LS/MS/HS)	m³/h	280/400/460	280/400/460	320/460/550	490/620/830	700/950/1050
Dehumidification	l/h	0.8	1.0	1.2	1.7	2.3
Outline dimensions (WxHxD)	mm	750x280x198	750x280x198	835x280x198	990x315x218	1186x343x258
Package dimensions (WxHxD)	mm	830x355x270	830x355x270	910x355x270	1065x300x400	1265x420x340
Net weight/Gross weight	kg	7.7/9.9	7.8/9.9	8.7/11.2	11.8/15	15.6/20.6
Part number		7SP023048	7SP023034	7SP023035	7SP023036	7SP023037
OUTDOOR UNIT						
Sound pressure level to 1 m	dB(A)		50	50	53	59
Sound power level	dB(A)		60	60	63	69
Airflow	m³/h		1900	2000	2100	2700
Compressor type			Rotary DC Inverter			
Outline dimensions (WxHxD)	mm		770x555x300	800x554x333	800x554x333	845x702x363
Package dimensions (WxHxD)	mm		900x585x345	920x615x390	920x615x390	965x755x395
Net weight/Gross weight	kg		26.6/29	29.1/31.9	37.8/40.5	48.4/51.6
Part number			7SP062878	7SP062879	7SP062880	7SP062881
POWER SUPPLY 1~230V - 50 HZ						
Power supply side		Outdoor	Outdoor	Outdoor	Outdoor	Outdoor
Power cable section	mm²		3x1.5	3x1.5	3x1.5	3x2.5
Fuse rating	A		10	10	16	25
Electrical connections	mm²	4x1.0	5x1.5	5x1.5	5x1.5	5x2.5
PIPE LINE						
Suction pipe diameter	inches	3/8"	3/8"	3/8"	1/2"	5/8"
Liquid pipe diameter	inches	1/4"	1/4"	1/4"	1/4"	3/8"
Max. length	m		25	25	30	50
Max. height	m		10	10	20	25

COMBINATIONS		
Indoor unit	Compatible with outdoor unit	
	Monosplit	Multisplit
HND 7 		YZC 
HND 9 to 24 	YND 	YZC 



+ PRODUCTS

- Competitive and multi matching solution.
- Operating down to -15°C in cooling and heating mode.
- **WiFi option.**
- Auto restart.



FEATURES



- “I Feel” function with precise room temperature control.
- Left/right drain connection.
- Multifan speed in indoor unit.
- Self clean/dry.



Refrigerant leakage detection alarm system

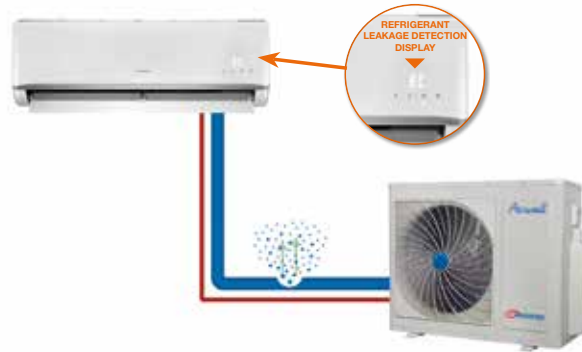

OPTIONS

Accessory	Part number	Photo	Function
Wired single control RCW8	7ACEL1706		Mode, fan speed, timer ON/OFF, temperature, swing and “I Feel”.
Test tool for high wall	7ACEL1710		Easy viewing of system parameters, failure records and parameter adjustments.
ON-OFF dry contact adaptor	7ACEL1190		Remote control based on last memorized operation. Easy to connect with a weekly timer and window contact.
Air Net WiFi Module	7ACEL1719		Control air conditioners with your mobile phone, tablet or computer with wireless router and internet.







HKD TECHNICAL DATA					
Indoor units		AWSI-HKD009-N11	AWSI-HKD012-N11	AWSI-HKD018-N11	AWSI-HKD024-N11
Outdoor units		AWAU-YKD009-H11	AWAU-YKD012-H11	AWAU-YKD018-H11	AWAU-YKD024-H11
COOLING					
Rated power	kW	2.65 (1.2-3.3)	3.54 (1.3-4.4)	5.0 (1.8-6.1)	6.8 (2.7-7.8)
Pdesignc	kW	2.65	3.54	5.0	6.8
Rated power input	kW	0.775	1.095	1.544	2.41
SEER/Energy label		6.9/A++	6.8/A++	6.5/A++	6.3/A++
Operating limits	°C	-15°/50° Dry bulb			
HEATING					
Rated power	kW	2.8 (0.85-3.7)	3.5 (1.2-4.8)	5.0 (1.4-6.7)	7.5 (1.6-8.7)
Pdesignh (average climate)	kW	2.4	2.6	4.2	5.5
Pdesignh (warmer climate)	kW	2.8	3.2	4.6	6.7
Pdesignh (colder climate)	kW	3	3.2	5	7
Rated power input	kW	0.72	0.94	1.35	2.34
SCOP/Energy label (average climate)		4/A+	4.4/A+	4.2/A+	4/A+
SCOP/Energy label (warmer climate)		5.1/A+++	5.3/A+++	5.1/A+++	5.1/A+++
SCOP/Energy label (colder climate)		3.3/B	3.4/A	3.3/B	3.3/B
Operating limits	°C	-15°/30° Dry bulb			
Power @ -10°C	kW	2.70	3.00	4.10	6.20
Power @ -15°C	kW	2.40	2.50	3.60	5.50
INDOOR UNIT					
Sound pressure level to 1 m (VL/LS/MS/HS)	dB(A)	22/31/35/38	23/29/32/36	23/29/33/36	31/37/40/43
Sound power level	dB(A)	54	53	57	63
Airflow (VL/LS/MS/HS)	m³/h	230/320/380/430	310/390/430/480	360/460/540/610	650/820/890/960
Dehumidification	l/h	1.0	1.2	1.7	2.4
Outline dimensions (WxHxD)	mm	715x250x188	800x275x188	940x275x205	1045x315x235
Package dimensions (WxHxD)	mm	775x324x260	865x350x265	1015x265x350	1135x315x395
Net weight/Gross weight	kg	6.5/8.2	7.4/9.5	9/12.2	12/15.2
Part number		7SP023030	7SP023031	7SP023032	7SP023033
OUTDOOR UNIT					
Sound pressure level to 1 m	dB(A)	50	52	55	59
Sound power level	dB(A)	60	62	65	68
Airflow	m³/h	1900	2000	2100	2700
Compressor type		Rotary DC Inverter	Rotary DC Inverter	Rotary DC Inverter	Rotary DC Inverter
Outline dimensions (WxHxD)	mm	770x555x300	800x554x333	800x554x333	845x702x363
Package dimensions (WxHxD)	mm	900x585x345	920x615x390	920x615x390	965x755x395
Net weight/Gross weight	kg	26.6/29	29.1/31.9	37.8/40.5	48.4/51.6
Part number		7SP062874	7SP062875	7SP062876	7SP062877
POWER SUPPLY 1~230V - 50 HZ					
Power supply side		Outdoor	Outdoor	Outdoor	Outdoor
Power cable section	mm²	3x1.5	3x1.5	3x1.5	3x2.5
Fuse rating	A	10	10	16	25
Electrical connections	mm²	5x1.5	5x1.5	5x1.5	5x2.5
PIPE LINE					
Suction pipe diameter	inches	3/8"	3/8"	1/2"	5/8"
Liquid pipe diameter	inches	1/4"	1/4"	1/4"	3/8"
Max. length	m	25	25	30	50
Max. height	m	10	10	20	25

COMBINATIONS

Indoor unit	Compatible with outdoor unit	
	Monosplit	Multisplit
High wall	YKD	YCZ
HKD 9 to 24		

Ducted Range

[MODEL NAME]			Special feature	Page
INVERTER DUCTED LOW STATIC PRESSURE MONOSPLIT	DLF		Horizontal and vertical installation	40
INVERTER DUCTED MEDIUM STATIC PRESSURE MONOSPLIT	DLSE		Zone control: Ideal temperature in each room	44
DUCTED MEDIUM STATIC PRESSURE MONOSPLIT	DID NEW		Residential ducted unit	52
DUCTED HIGH STATIC PRESSURE MONOSPLIT	DED NEW		Light commercial ducted unit	56

12 18 24 30 36 45 60 76 95
3.5 kW **5 kW** **7 kW** **8 kW** **10 kW** **12.5 kW** **16 kW** **22 kW** **28 kW**



Unique solutions



D L F

Unique and advanced design for vertical or horizontal installation

VERTICAL INSTALLATION

- Vertical installation with compact dimensions, only 200 mm depth.
- The best solution for replacing radiator.
- The best solution in rooms with no space for ceiling installation.
- Creates a clean and modern design after installation.

【 BEFORE 】



【 AFTER 】



【 COMBINATION MODERN CONSTRUCTION 】

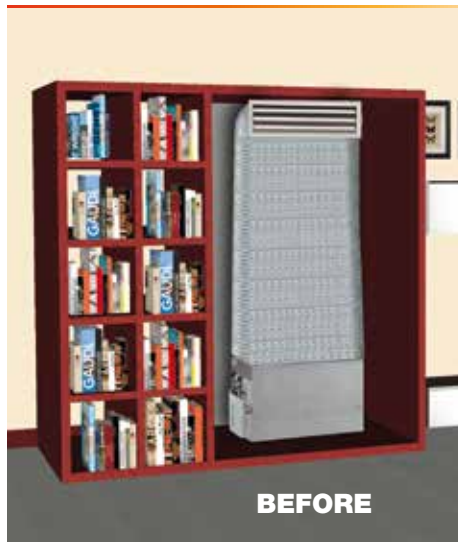

HORIZONTAL INSTALLATION

- Space saving by minimizing the requirement of ceiling height.
- Ideal solution for hotel and bedroom due to super quiet and extremely compact design.

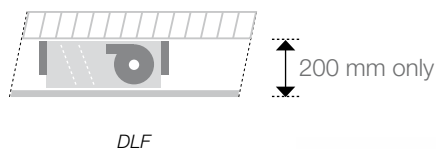
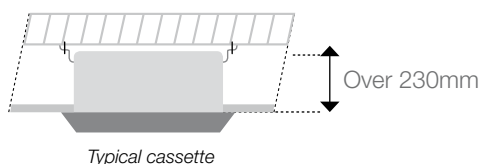

COMPREHENSIVE STRUCTURE DESIGN

- | | |
|-----------------------------------|---------------------|
| A Drain pan | E Fan |
| B Coil | F Controller |
| C DC motor | G Air filter |
| D Water pump + water level | |

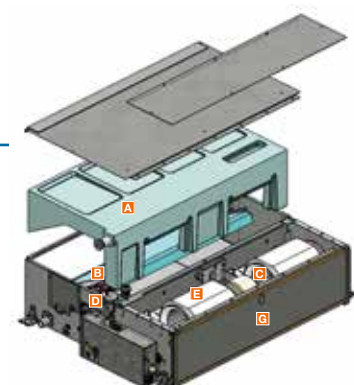



Unique solutions

+ PRODUCTS

- Horizontal or vertical installation.
- Extra slim.
- Water pump included.



RCW2 RC08W (optional)

FEATURES

DC INVERTER	LOW VOLTAGE STARTUP	LOW TEMPERATURE STARTUP	R410A FLUID
ELECTRONIC EXPANSION VALVE	AUTO CLEAN/DRY	FILTER CLEAN INDICATION	I FEEL
SLEEP MODE	SUPER QUIET	TURBO MODE	PROGRAMMABLE TIMER
SELF DIAGNOSTIC	LOW BATTERY INDICATION	AUTO RESTART (MEMORY)	REMOTE CONTROL LOCK
ADVANCED DEFROST	INTEGRATED WATER PUMP	FREQUENCY CONTROL INCLUDING AIRFLOW	ALARM OUTPUT
BMS COMPATIBLE	SERVICE MONITOR TOOL	POWER CONSUMPTION CONTROL	WIRED REMOTE CONTROL DIAGNOSTIC
ODU	ODU	STBY ODU	ODU
OUTDOOR UNIT DIGITAL DIAGNOSTIC	OUTDOOR UNIT NIGHT MODE DRY CONTACT	OUTDOOR UNIT STAND-BY	OUTDOOR UNIT ALARM OUTPUT
FULL LENGTH REFRIGERANT PRECHARGE	TECHNICIAN TEST MODE	LOW AMBIENT COOLING	LOW AMBIENT HEATING
WIFI			

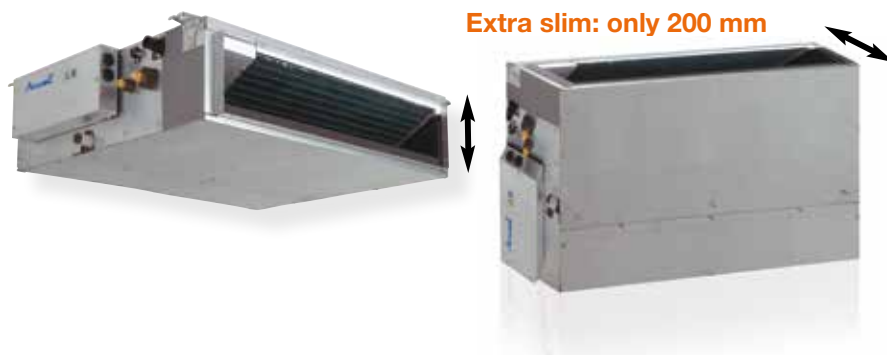

- "I Feel" function with precise room temperature control.
- Super quiet line thanks to advance aerodynamic fans and DC motor.
- Heating mode only force option.
- Treatment of corrosion on outdoor units and electronic cards.
- Possibility to reverse dry contact: normally open/normally closed.



OPTIONS

Accessory	Part number	Photo	Function										
Wireless controller RC08W	7ACEL1741		Operation mode, sleep mode, timer, I Feel, swing, clean mode...										
Duct plenum for DLF 18	7ACVF0516		Round duct connection with the following combination.										
Duct plenum for DLF 24	7ACVF0517		<table border="1"> <thead> <tr> <th rowspan="2">Indoor model name</th> <th colspan="2">Hoses connection</th> </tr> <tr> <th>Option 1</th> <th>Option 2</th> </tr> </thead> <tbody> <tr> <td>DLF 18</td> <td>3x160mm</td> <td>1x160mm + 1x200mm</td> </tr> <tr> <td>DLF 24</td> <td>4x160mm</td> <td>1x160mm + 1x200mm</td> </tr> </tbody> </table>	Indoor model name	Hoses connection		Option 1	Option 2	DLF 18	3x160mm	1x160mm + 1x200mm	DLF 24	4x160mm
Indoor model name	Hoses connection												
	Option 1	Option 2											
DLF 18	3x160mm	1x160mm + 1x200mm											
DLF 24	4x160mm	1x160mm + 1x200mm											



DLF TECHNICAL DATA

Indoor units		AWSI-DLF018-N11	AWSI-DLF024-N11
Outdoor units		AWAU-YBDE018-H11	AWAU-YBDE024-H11
COOLING			
Rated power	kW	5.0 (1.5-5.8)	7.0 (1.5-7.5)
Pdesignc	kW	5.0	7.0
Rated power input	kW	1.23	1.70
SEER/Energy label		5.4/A	5.6/A+
Operating limits	°C	-10°/46° dry bulb	
HEATING			
Rated power	kW	5.6 (1.3-6.8)	7.6 (1.5-8.8)
Pdesignh	kW	4.8	7.5
Rated power input	kW	1.52	1.78
SCOP/Energy label (average climate)		3.9/A	3.8/A
SCOP/Energy label (warmer climate)		4.3/A+	4.7/A++
Operating limits	°C	-15°/24° dry bulb	
Power @ -10°C	kW	5.3	5.4
Power @ -15°C	kW	4.7	4.8
INDOOR UNIT			
Sound pressure level to 1 m (LS/MS/HS)	dB(A)	29/32/35	32/35/39
Sound power level (LS/MS/HS)	dB(A)	48/51/54	56/59/63
Airflow (LS/MS/HS)	m³/h	540/600/710	900/950/1150
External static pressure Range	Pa	0-40	0-40
Dehumidification	l/h	1.8	2.7
Outline dimensions (WxHxD)	mm	750x200x630	1050x200x630
Package dimensions (WxHxD)	mm	890x243x710	1190x243x710
Net weight/Gross weight	kg	21/23	25/28
Part number		7SP022748	7SP022749
OUTDOOR UNIT			
Sound pressure level to 1 m	dB(A)	53	55
Sound power level	dB(A)	65	67
Airflow	m³/h	2500	2750
Compressor type		Twin Rotary DC Inverter	Twin Rotary DC Inverter
Outline dimensions (WxHxD)	mm	900x700x340	900x700x340
Package dimensions (WxHxD)	mm	985x730x435	985x730x435
Net weight/Gross weight	kg	56/58.5	61/63.5
Part number		7SP061886	7SP061887
POWER SUPPLY 1~230V - 50 HZ			
Power supply side		Indoor & Outdoor	Outdoor
Power cable section	mm²	3x2.5	3x2.5
Fuse rating am	A	20	20
Electrical connections	mm²	4x1.5	4x1.5
PIPE LINE			
Suction pipe diameter	inches	1/2"	5/8"
Liquid pipe diameter	inches	1/4"	3/8"
Max. length	m	30	30
Max. height	m	15	15

COMBINATIONS

Indoor unit	Compatible with outdoor unit
Ducted	Monosplit
<p>DLF</p> 	<p>YBDE</p> 



Unique
solutions

DLSE Plus VAV

Variable Air Volume



Zone control: Ideal temperature in each room



ZONE CONTROL FUNCTION

- Smart air conditioning: Controls up to 6 rooms.
- Each zone has a standalone remote control, to control temperature, "I Feel" and ON/OFF.
- Option to define automatic damper movement or manually to keep max. opening position.
- By-pass damper operates according to system load, which ensures air circulation in the indoor unit.
- Auto-mode: automatically recognizes cooling or heating mode.
- Motorized damper with DC step motor for accurate damper position.
- The blowing dampers change their position (open/close), in accordance with the temperature setpoint in each room, which keeps required temperature.

ENERGY AND COST SAVING

- Two levels of energy saving:
 - by the inverter system following the area load,
 - stops the system when all rooms have reached the chosen temperature and reduces the motor speed.

COST COMPARISON BETWEEN 2 SYSTEMS ON A "STANDARD" HOUSE.

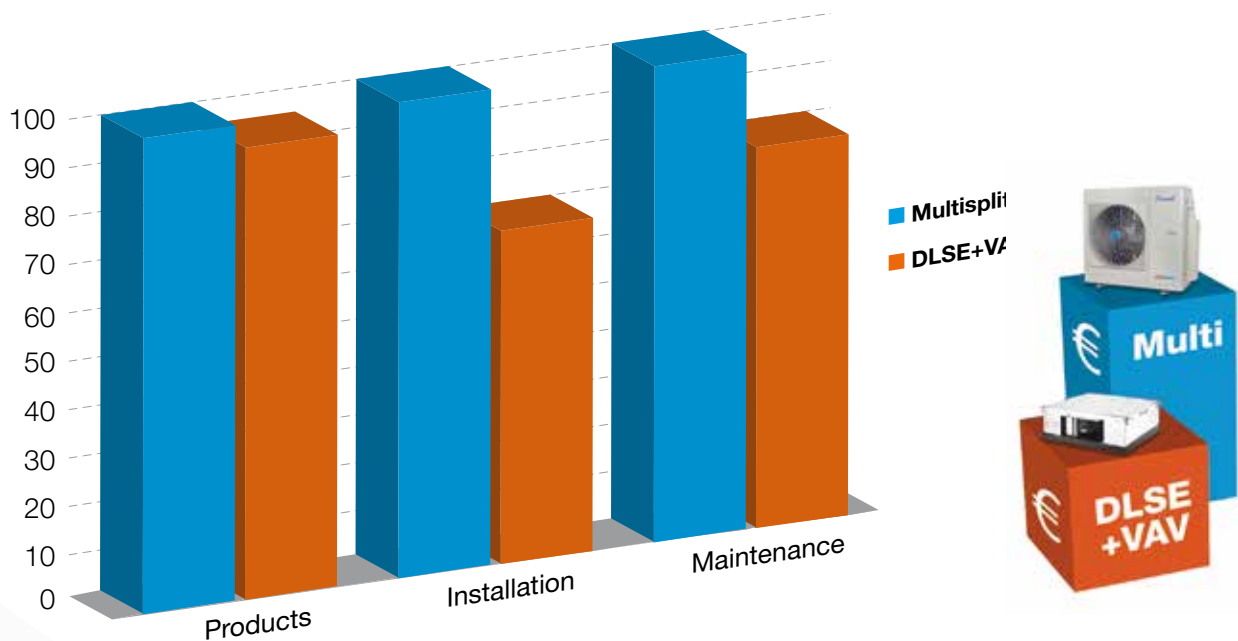

EASY INSTALLATION

- Simple wiring connection by connectors and set up.
- Up to 70m between indoor and outdoor units.
- Monosplit indoor unit: time saving (little tubing).
- Option for installing the control box besides the unit.
- Water pump and overflow switch built in.

Good to know!

Use our design document to select easily your system.
Ask us this helpful file: mkg@airwell-res.com

SPECIAL DESIGN FOR YOUR CONVENIENCE

- Unique V shape coil.
- Extra slim indoor unit (low height: 256 mm only).

STANDARD DESIGN

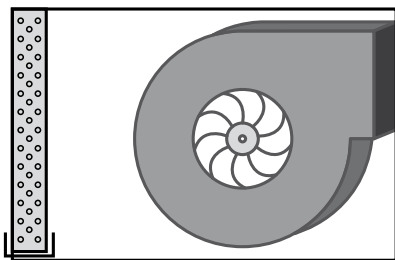

DLSE

Horizontal fan, higher air volume + high static pressure

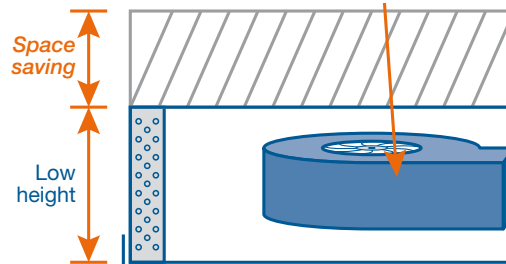

full profile limits risks of condensation

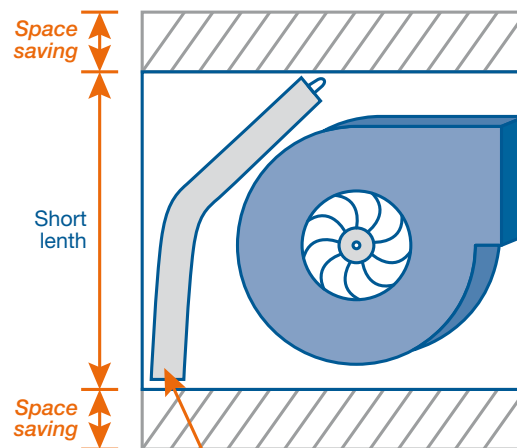
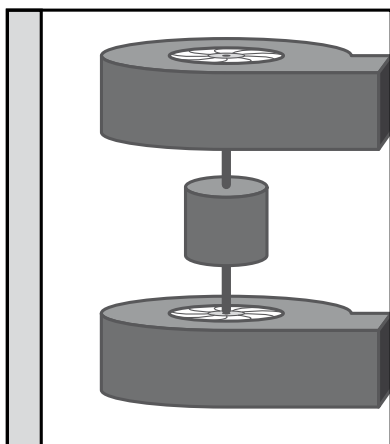

V shape coil for better performance and compact design

How to order?

- For each installation select first the damper type, round or rectangular.
- The main controller is identical except the set up which is done during the installation.
- After that, select motorized round damper, by-pass damper and plenum (see table below).

ROUND APPLICATION

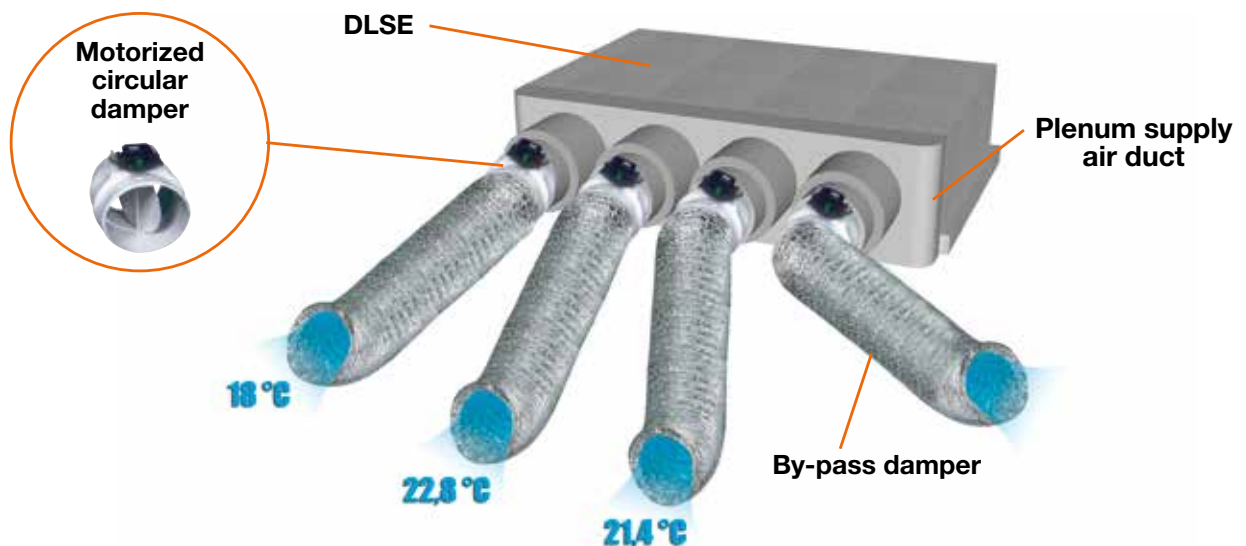

MOTORIZED ROUND TYPE ACCESSORIES

Part description	Product code
Main controller VAV kit	7ACEL1641
Motorized round damper (D=150 mm) kit (Wireless controller C85-R included)	7ACEL1648
Motorized round damper (D=200 mm) kit (Wireless controller C85-R included)	7ACEL1649
Motorized round damper (D=250 mm) kit (Wireless controller C85-R included)	7ACEL1650
Motorized by-pass round damper (D=200 mm) kit (Wireless controller C85-R included)	7ACEL1651
Motorized by-pass round damper (D=250 mm) kit (Wireless controller C85-R included)	7ACEL1652

PLENUM ACCESSORIES: ROUND APPLICATION

Part description	Models	Product code
Air duct plenum - 4 ducts + 1 by-pass	DLSE 18/24	7ACVF0130
Air duct plenum - 6 ducts + 1 by-pass	DLSE 18/24	7ACVF0131
Air return grill	DLSE 18/24	7ACVF0132
Air duct plenum - 4 ducts + 1 by-pass	DLSE 30 and up	7ACVF0133
Air duct plenum - 6 ducts + 1 by-pass	DLSE 30 and up	7ACVF0134
Air return grill	DLSE 30 and up	7ACVF0135

RECTANGULAR APPLICATION

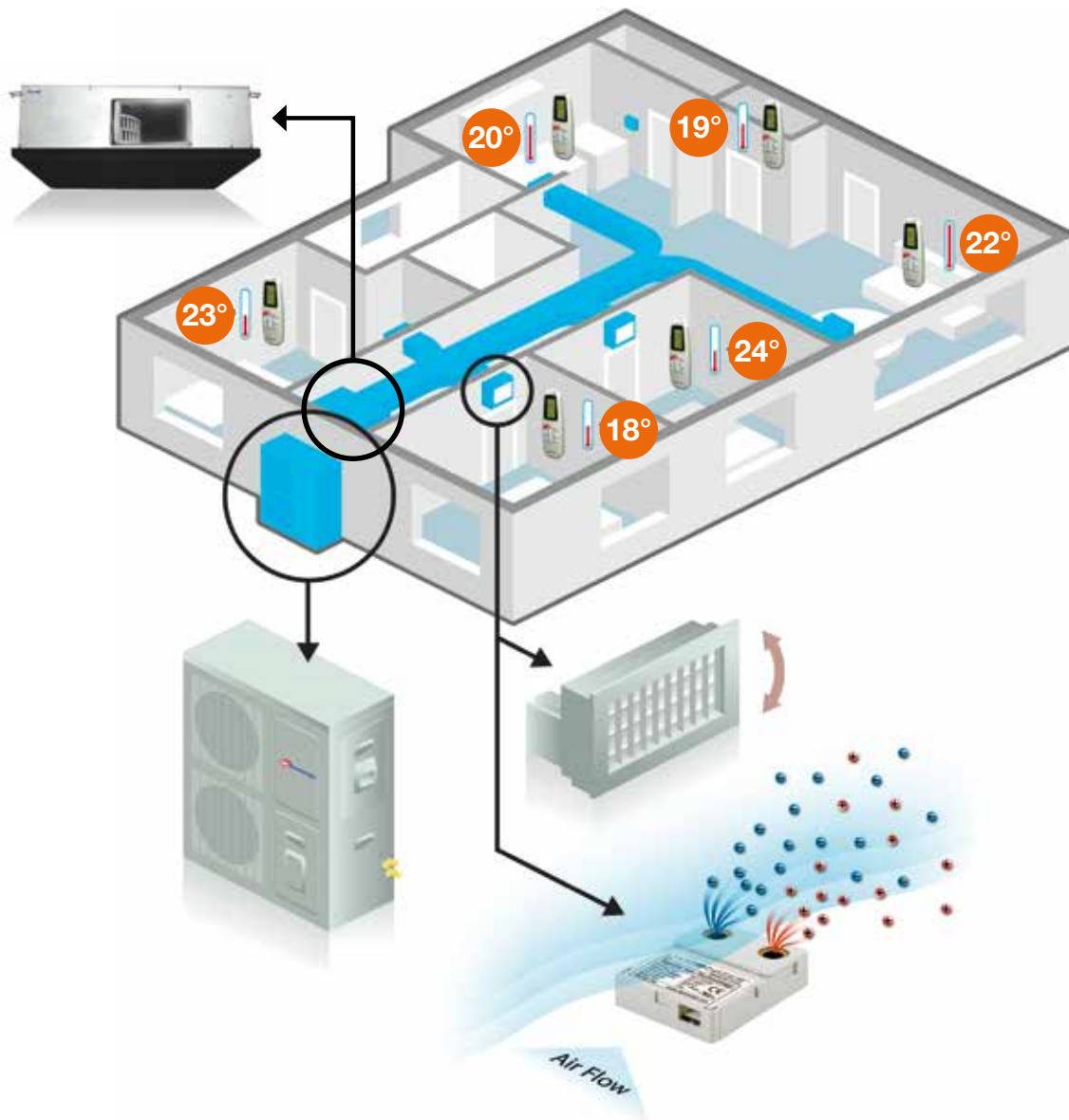

MOTORIZED RECTANGULAR TYPE ACCESSORIES

Part description	Product code
Main controller VAV kit	7ACEL1641
Motorized grill (30 cm x 15 cm) kit (Wireless controller C85-R included)	7ACEL1642
Motorized grill (40 cm x 15 cm) kit (Wireless controller C85-R included)	7ACEL1643
Motorized grill (50 cm x 15 cm) kit (Wireless controller C85-R included)	7ACEL1644
Motorized by-pass damper (40 cm x 15 cm) kit	7ACEL1645
Motorized by-pass damper (50 cm x 15 cm) kit	7ACEL1646
Duct frame profile for grille 150 mm	7ACVF0551
Duct frame profile for grille 300 mm	7ACVF0552
Duct frame profile for grille 400 mm	7ACVF0553
Duct frame profile for grille 500 mm	7ACVF0554
Sterionizer kit for motorized grill	7ACEL1655

Monosplit DCI
Cooling & heating

DLSE+VAV DUCTED MEDIUM STATIC PRESSURE MONOSPLIT



A⁺⁺

Unique solutions

+ PRODUCTS

- Variable Air Volume Solution.
- Weekly timer.
- Water pump included.
- Super quiet.



RCW2 C85-R (included with damper) RC08W (optional)

FEATURES

DC INVERTER	LOW VOLTAGE STARTUP	LOW TEMPERATURE STARTUP	R410A FLUID
VAV COMPATIBILITY	ELECTRONIC EXPANSION VALVE	I FEEL	SLEEP MODE
SUPER QUIET	TURBO MODE	24 H PROGRAMMABLE TIMER	SELF DIAGNOSTIC
LOW BATTERY INDICATION	AUTO RESTART (MEMORY)	REMOTE CONTROL LOCK	ADVANCED DEFROST
ALARM OUTPUT	BMS COMPATIBLE	SERVICE MONITOR TOOL	POWER CONSUMPTION CONTROL
WIRED REMOTE CONTROL DIAGNOSTIC	OUTDOOR UNIT DIGITAL DIAGNOSTIC	OUTDOOR UNIT NIGHT MODE DRY CONTACT (DLSE 24-30-36)	OUTDOOR UNIT STAND-BY (DLSE 24-30-36)
OUTDOOR UNIT ALARM OUTPUT (DLSE 24-30-36)	TEST MODE	-10°C LOW AMBIENT COOLING	-15°C LOW AMBIENT HEATING
STERIONIZER (WITH MOTORIZED GRILL)	WIFI		

- “I Feel” function with precise room temperature control.
- Unique fan technology increases air volume and high static pressure while keeping low noise level.
- Quiet operation by using aerodynamic centrifugal fan.
- Space saving due to low unit height and compact dimensions.
- Tubing length up to 70 m and max. height of 30 m.
- External static pressure up to 100 Pa.
- Possibility to reverse dry contact: normally open/normally closed.



GLOBAL AND INVISIBLE SOLUTION FOR YOUR HOME

Indoor unit

Outdoor unit

OPTIONS

Accessory	Part number	Photo	Function
Wireless controller RC08W	7ACEL1741		Operation mode, sleep mode, timer, I Feel, swing, clean mode...

DLSE TECHNICAL DATA

Indoor units		AWSI-DLSE018-N11	AWSI-DLSE024-N11	AWSI-DLSE030-N11	AWSI-DLSE036-N11		AWSI-DLSE043-N11	
		AWAU-YBDE018-H11	AWAU-YBDE024-H11	AWAU-YBDE030-H11	AWAU-YBD036-H11	AWAU-YBD036-H13	AWAU-YBD042-H11	AWAU-YAD042-H13
COOLING								
Rated power	kW	5.0 (2.3-5.9)	6.8 (1.7-7.4)	7.5 (2.8-8.4)	9.5 (4.8-12.5)	9.5 (4.8-12.5)	12.5 (4.5-14.5)	12.5 (4.5-14.5)
Pdesignc	kW	5.0	6.8	7.5	9.5	9.5	-	-
Rated power input	kW	1.22	1.93	2.46	3.31	3.04	3.73	3.56
SEER/Energy label		5.8/A+	5.4/A	5.5/A	5.6/A+	4.7/B	3.35/A	3.51/A
Operating limits	°C	-10°/46° Dry bulb						
HEATING								
Rated power	kW	5.6 (1.9-7.5)	7.6 (1.8-8.5)	8.6 (2.8-9.4)	10.5 (2.7-12.5)	11.6 (4.9-12.5)	14.0 (4.5-16.0)	14.0 (4.5-16.0)
Pdesignh		5.5	7.5	8.6	9.5	10.5	-	-
Rated power input	kW	1.35	1.88	2.31	2.80	3.00	4.1	3.99
SCOP/Energy label (average climate)		3.9/A	3.8/A	3.9/A	3.8/A	3.9/A	3.41/B	3.51/B
SCOP/Energy label (warmer climate)		4.6/A+	4.9/A++	4.3/A+	4.6/A+	4.7/A++	-	-
Operating limits	°C	-15°/24° Dry bulb						
Power @ -10°C	kW	5.3	5.8	7.1	6.9	8.9	9.3	9.3
Power @ -15°C	kW	4.7	5.2	6.3	6.2	8.0	8.3	8.3
INDOOR UNIT								
Sound pressure level to 1 m (LS/MS/HS/SS)	dB(A)	35/38/41/43	38/42/45/48	39/43/46/48	41/45/46/48	41/45/46/48	42/46/53	42/46/53
Sound power level (LS/MS/HS/SS)	dB(A)	52/55/58/60	55/59/62/65	56/60/63/65	56/61/63/65	56/61/63/65	57/61/70	57/61/70
Airflow (LS/MS/HS/SS)	m³/h	740/875/1060/1150	870/1090/1220/1410	950/1140/1290/1410	1290/1550/1670/1750	1290/1550/1670/1750	1315/1530/2025	1315/1530/2025
External static pressure Range	Pa	25 (25-60)	25 (25-80)	25 (25-80)	37 (37-100)	37 (37-100)	50 (50-100)	50 (50-100)
Dehumidification	l/h	1.5	2.3	2.7	3.5	4.6	3.3	3.8
Outline dimensions (WxHxD)	mm	790x256x749	790x256x749	790x256x749	854x297x816	854x297x816	854x297x816	854x297x816
Package dimensions (WxHxD)	mm	960x300x855	960x300x855	960x300x855	1005x345x915	1005x345x915	1005x345x915	1005x345x915
Net weight/Gross weight	kg	29/31.5	30/32.5	31/33.5	33/35.5	33/35.5	33/35.5	33/35.5
Part number		7SP032154	7SP032155	7SP032156	7SP032157	7SP032157	7SP032087	7SP032087
OUTDOOR UNIT								
Sound pressure level to 1 m	dB(A)	53	55	56	58	58	58	58
Sound power level	dB(A)	65	67	68	69	69	70	70
Airflow	m³/h	2500	2750	3400	4150	4150	5700	5700
Compressor type		Twin Rotary DC Inverter	Twin Rotary DC Inverter	Twin Rotary DC Inverter	Twin Rotary DC Inverter	Twin Rotary DC Inverter	Scroll DC Inverter	Twin Rotary DC Inverter
Outline dimensions (WxHxD)	mm	900x700x340	900x700x340	900x860x340	900x970x340	900x970x340	900x1250x340	900x1250x340
Package dimensions (WxHxD)	mm	985x730x435	985x730x435	985x905x435	985x1020x435	985x1020x435	980x1400x420	980x1400x420
Net weight/Gross weight	kg	56/58.5	61/63.5	66/68.5	80/82.8	85/87.8	110/121	110/121
Part number 1-230V - 50 Hz		7SP061886	7SP061887	7SP061922	7SP061923	-	7SP061815	-
Part number 3-400V - 50 Hz - N		-	-	-	-	7SP061900	-	7SP061757
POWER SUPPLY 1-230V - 50 HZ								
Power supply side		Ind. & Out.	Outdoor	Outdoor	Outdoor	-	Outdoor	-
Power cable section	mm²	3x2.5	3x2.5	3x2.5	3x4.0	-	3x6.0	-
Fuse rating am	A	20	20	20	25	-	32	-
Electrical connections	mm²	4x1.5	4x1.5	4x1.5	3x1.5 + 2x0.75	-	3x1.5 + 2x0.75	-
POWER SUPPLY 3-400V - 50 HZ - N								
Power supply side		-	-	-	-	Outdoor	-	Outdoor
Power cable section	mm²	-	-	-	-	5x2.5	-	5x2.5
Fuse rating am	A	-	-	-	-	3x16	-	3x16
Electrical connections	mm²	-	-	-	-	3x1.5 + 2x0.75	-	3x1.5 + 2x0.75
PIPE LINE								
Suction pipe diameter	inches	1/2"	5/8"	5/8"	5/8"	5/8"	3/4"	3/4"
Liquid pipe diameter	inches	1/4"	3/8"	3/8"	3/8"	3/8"	3/8"	3/8"
Max. length	m	30	30	50	70	70	70	70
Max. height	m	15	15	25	30	30	30	30

COMBINATIONS

Indoor unit	Compatible with outdoor unit
Ducted	Monosplit
DLSE 18	YBDE
	
DLSE 24 to 43	YBDE
	

• Unique
• solutions

DID 

Twin application

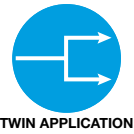

TWIN APPLICATION

The twin application is used mainly in big open space where the total space area is controlled by one controller only for 2 units. Airwell twin design allows to connect two similar indoor units to one common outdoor unit. The two indoor units are working in a same mode and set up only once, one indoor unit used as master.

The most cost saving solution for single-area spaces:

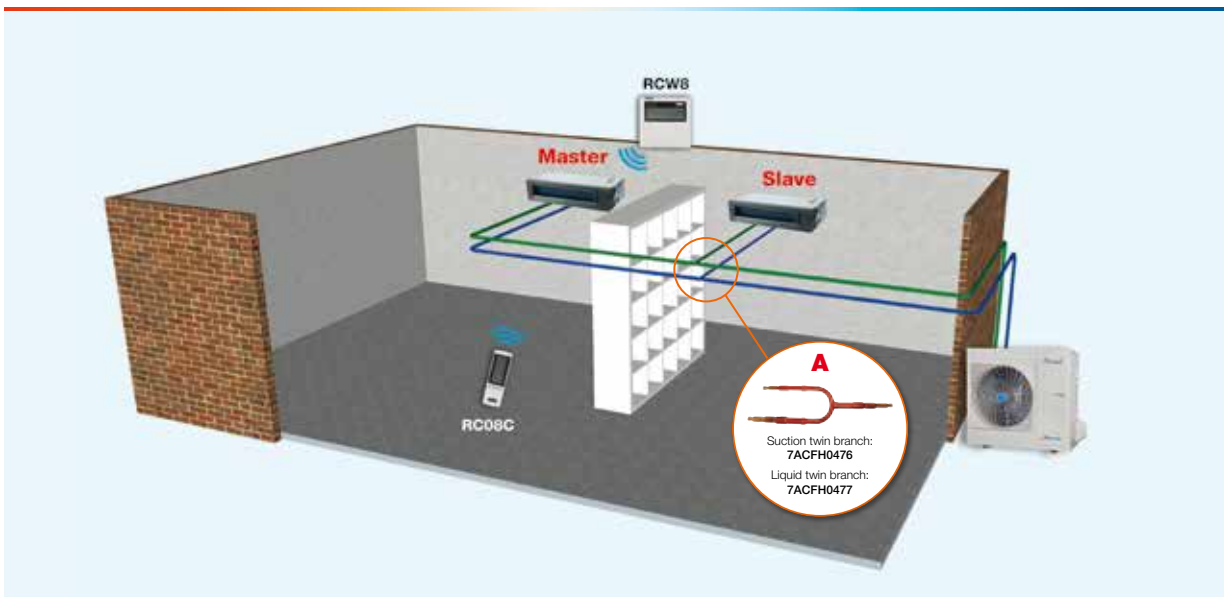

- Simple installation by having one refrigerant and control system.
- Space saving by using one outdoor unit instead of two.
- Low cost installation.
- Simple control, one control station for big space.
- Option to control by wireless or wired controller.
- Ducted or cassette application.



	Indoor units	Outdoor units
Twin system	DID018 + DID018	YMD036
	DID024 + DID024	YMD048

Tubeing & charge instructions	YMD036	YMD048
Pipe diameter (liquid-gas) (inches)	3/8"-5/8"	
Max. length (m)	30	50
Max. difference in branch length (m)	10	
Max. height drop between indoor units (m)	0.5	
Max. height drop between indoor and outdoor units (m)	20	
Max. branch length (m)	15	

MANDATORY ACCESSORIES

Accessory	Part number	Photo	Description	Function
Branch gas	7ACFH0476		Twin branch suction	Tube branch to collect all suction lines. Mandatory for Twin application.
Branch liquid	7ACFH0477		Twin branch liquid	Tube branch to collect all liquid lines. Mandatory for Twin application.



DID 012



DID 018-060

NEW



+ PRODUCTS

- Twin application.
- Full range of accessories and controls.
- Possibility to wire a water pump.
- Air return option from rear or bottom side.



RCW8



RC08C
(optional)



RCW6
(optional)

FEATURES



FLEX MATCH



DC INVERTER



R410A FLUID



ELECTRONIC EXPANSION VALVE



FRESH AIR



I FEEL



SLEEP MODE



HOT KEEP



DIGITAL DISPLAY



PROGRAMMABLE TIMER



SELF DIAGNOSTIC



LOW BATTERY INDICATION



RESTART



REMOTE CONTROL LOCK



AUTO MODE OPERATION



AUTO FAN



OUTDOOR MULTI FAN SPEED



INTEGRATED WATER PUMP



LEFT/RIGHT DRAIN CONNECTION



TWIN APPLICATION



STATIC PRESSURE CONTROL



ALARM OUTPUT



UNIT ON INPUT



LOW AMBIENT COOLING



LOW AMBIENT HEATING



BMS COMPATIBLE



WIFI

- DC Inverter and sine wave compressor drive technology.
- "I Feel" function with precise room temperature control.
- Option to connect to central controller or wireless remote control.
- Air filter is included.
- Easy maintenance: access to electronic box, filters.



OPTIONS

Accessory	Part number	Description	Photo	Function
Wireless controller RC08C	7ACEL1740			Timer, eco mode, "Follow me" option, swing, technician mode.
Wired single control RCW6	7ACEL1704			Mode, fan speed, real time, timer, temperature, weekly timer, swing and "I Feel".
Central controller RCW16	7ACEL1707			Controls up to 64 indoor units with individual setting failure codes indication, ON-OFF dry contact, last operation memory, Modbus.
BMS gateway	7ACEL1708			Maximum 1024 units could be connected (16 gateways).
Insulated air duct plenum	7ACVF0136	2 ducts DN160		For DID 12
	7ACVF0137	3 ducts DN 160		For DID 18
	7ACVF0138	3 ducts DN 160		For DID 24
	7ACVF0139	3 ducts DN 160		For DID 30
	7ACVF0140	3 ducts DN 160		For DID 36/42/48/60









All sizes except DID 048-060

DID TECHNICAL DATA

Indoor unit		AWSI-DID012-N11	AWSI-DID018-N11	AWSI-DID024-N11	AWSI-DID036-N11	AWSI-DID036-N11	AWSI-DID048-N11	AWSI-DID060-N11
Outdoor unit 1~230V - 50 Hz		AWAU-YMD012-H11	AWAU-YMD018-H11	AWAU-YMD024-H11	AWAU-YMD036-H11	-	-	-
Outdoor units 3~400V - 50 Hz		-	-	-	-	AWAU-YMD036-H13	AWAU-YMD048-H13	AWAU-YMD060-H13
COOLING								
Rated power	kW	3.5 (0.6-4.4)	5.1 (0.8-6.1)	7 (1.2-8.2)	10.0 (2.9-12.0)	10.0 (2.9-12.0)	14.0 (4.1-16.4)	16 (5.0-18.1)
Pdesignnc	kW	3.5	5.1	7	10.0	10.0	14.0	16
Rated power input	kW	1.023	1.579	2.167	3.817	3.817	4.965	6.612
SEER/Energy label		6.1/A++	6.3/A++	6.1/A++	6.1/A++	6.1/A++	6.1/A++	5.6/A+
Operating limits	°C	-15°/50° Dry bulb						
HEATING								
Rated power	kW	3.8 (0.6-5.0)	5.8 (0.9-7.0)	7.3 (1.2-8.6)	11.5 (2.6-13.2)	11.5 (2.6-13.2)	16 (4.3-18.1)	18.0 (5.3-20.5)
Pdesignn (average climate)	kW	3.2	4.7	6	10.2	10.0	12	12.2
Pdesignn (warmer climate)	kW	3.6	5	6	10.5	10.5	12.2	12.4
Rated power input	kW	0.995	1.518	1.911	3.091	3.091	4.301	5.263
SCOP/Energy label (average climate)		4.0/A+	4.0/A+	4.0/A+	4.0/A+	4.0/A+	4.0/A+	4.0/A+
SCOP/Energy Label (warmer climate)		5.1/A+++	5.1/A+++	5.1/A+++	5.1/A+++	5.1/A+++	5.1/A+++	5.1/A+++
Operating limits	°C	-15°/24° Dry bulb						
Power @ -10°C	kW	3.2	4.8	7.6	9.8	9.5	12.9	14.1
Power @ -15°C	kW	2.7	3.8	6.2	7.6	7.6	10.1	12.3
INDOOR UNIT								
Sound pressure level to 1 m (LS/MS/HS)	dB(A)	27/31/35	38/40/42	38/40/42	38/40/42	42/44/46	48/50/52	54/56/58
Sound power level	dB(A)	57	59	62	63	63	69	74
Airflow (LS/MS/HS)	m³/h	450/580/680	690/850/980	780/1000/1200	920/1100/1400	920/1100/1400	1450/1740/2100	1800/2150/2500
External static pressure Range	Pa	25 (0-45)	25 (0-100)	25 (0-100)	37 (0-120)	37 (0-120)	50 (0-160)	50 (0-160)
Dehumidification	l/h	1.5	2	2.5	3.8	3.8	4.5	5.5
Outline dimensions (WxHxD)	mm	700x210x635	880x210x674	1100x774x249	1360x249x774	1360x249x774	1200x300x874	1200x300x874
Package dimensions (WxHxD)	mm	915x290x655	1070x270x725	130x3055x805	1570x305x805	1570x305x805	1405x355x915	1405x355x915
Net weight/Gross weight	kg	18.4/22.7	25.4/31	31.7/39.1	40.2/48.4	40.2/48.4	46/55.2	46/55.2
Part number		7SP032165	7SP032166	7SP032167	7SP032168	7SP032168	7SP032169	7SP032170
OUTDOOR UNIT								
Sound pressure level to 1 m	dB(A)	54	54	60	61	61	63	63
Sound power level	dB(A)	61	65	65	67	68	72	75
Airflow	m³/h	2000	2100	2700	4300	4300	6800	7200
Compressor type		Rotary DCI	Rotary DCI	Twin Rotary DCI	Twin Rotary DCI	Twin Rotary DCI	Twin Rotary DCI	Twin Rotary DCI
Refrigerant type/Ammount	kg	R410a/1.38	R410a/1.78	R410a/1.95	R410a/3.2	R410a/3.2	R410a/4.0	R410a/4.3
Outline dimensions (WxHxD)	mm	800x554x333	800x554x333	845x702x363	946x810x410	946x810x410	952x1333x415	952x1333x415
Package dimensions (WxHxD)	mm	920x615x390	920x615x390	965x765x396	1090x865x500	1090x865x500	1095x1470x500	1095x1470x500
Net weight/Gross weight	kg	34.5/37.3	35.5/38.4	49/51.5	67.2/72.9	78.9/83.9	108.1/121.2	112.8/126
Part number 1~230V - 50 Hz		7SP062891	7SP062892	7SP062893	7SP062895	-	-	-
Part number 3~400V - 50 Hz		-	-	-	-	7SP062896	7SP062899	7SP062900
POWER SUPPLY 1~230V - 50 HZ								
Power supply side		Outdoor	Ind. & Out.	Ind. & Out.	Ind. & Out.	-	-	-
Power cable section	mm²	3x1.5	3x1.0+3x2.5	3x1.0+3x2.5	3x1.0+3x4.0	-	-	-
Fuse rating am	A	16	10+16	10+25	10+30	-	-	-
Electrical connections	mm²	4x1.0	2x0.5	2x0.5	2x0.5	-	-	-
POWER SUPPLY 3~400V - 50 HZ								
Power supply side		-	-	-	-	Ind. & Out.	Ind. & Out.	Ind. & Out.
Power cable section	mm²	-	-	-	-	3x1.0+5x2.5	3x1.0+5x2.5	3x1.0+5x2.5
Fuse rating am	A	-	-	-	-	10+20	10+25	10+25
Electrical connections	mm²	-	-	-	-	2x0.5	2x0.5	2x0.5
PIPE LINE								
Suction pipe diameter	inches	3/8"	1/2"	5/8"	5/8"	5/8"	5/8"	5/8"
Liquid pipe diameter	inches	1/4"	1/4"	3/8"	3/8"	3/8"	3/8"	3/8"
Max. length	m	25	30	50	65	65	65	65
Max. height	m	10	20	25	30	30	30	30

COMBINATIONS

Indoor unit	Compatible with outdoor unit	
	Monosplit	Multisplit
DID 12 	YMD 	YCY 
DID 18 to 36 	YMD 	
DID 48 & 60 	YMD 	



NEW

+ PRODUCTS

- DC inverter technology.
- High static pressure.
- Commercial application.



RCW17



RCW18 (optional)

FEATURES

DC INVERTER	R410A FLUID	ELECTRONIC EXPANSION VALVE	I FEEL
SLEEP MODE	HOT KEEP	PROGRAMMABLE TIMER	SELF DIAGNOSTIC
AUTO RESTART (MEMORY)	REMOTE CONTROL LOCK	AUTO MODE OPERATION	AUTO FAN
INTEGRATED WATER PUMP	BMS COMPATIBLE	LOW AMBIENT HEATING	UNIT ON INPUT

- Front discharge outdoor for easy installation and saving space.
- Two compressors DC inverter operation optimization for better reliability and better efficiency of partial load.
- “I Feel” function with precise room temperature control.
- Air filter is included.
- Operating down to -20°C in heating mode.

OPTIONS

Accessory	Part number	Photo	Function
Wired single control RCW18	7ACEL1728		ON/OFF, mode, temperature, fan, swing, sleep mode, fresh air settings, turbo mode, error display, ON/OFF dry contact...

DED TECHNICAL DATA

Indoor units		AWSI-DED076-N11	AWSI-DED095-N11
Outdoor units		AWAU-YED076-H13	AWAU-YED095-H13
COOLING			
Rated power	kW	22.4	28.0
Rated power input	kW	6.70	8.30
EER		3.34	3.37
Operating limits	°C	10°/48° Dry bulb	
HEATING			
Rated power	kW	25.0	30.0
Rated power input	kW	6.54	8.15
COP		3.82	3.68
Operating limits	°C	-20°/27° Dry bulb	
Power @ -10°C	kW	20.5	24.6
Power @ -15°C	kW	17.5	21.0
INDOOR UNIT			
Sound pressure level to 1 m	dB(A)	54	55
Sound power level	dB(A)	64	65
Airflow	m³/h	4000	4400
External static pressure range	Pa	150 (0-200)	150 (0-200)
Dehumidification	l/h	7.5	8.5
Outline dimensions (WxHxD)	mm	1483x385x791	1686x450x870
Package dimensions (WxHxD)	mm	1578x472x883	1788x580x988
Net weight/Gross weight	kg	82/104	105/140
Part number		7SP032160	7SP032161
OUTDOOR UNIT			
Sound pressure level to 1 m	dB(A)	60	61
Sound power level	dB(A)	70	71
Airflow	m³/h	9000	9000
Compressor type		Rotary DC Inverter x 2	Rotary DC Inverter x 2
Outline dimensions (WxHxD)	mm	1098x1584x399	1098x1584x399
Package dimensions (WxHxD)	mm	1183x1785x505	1183x1785x505
Net weight/Gross weight	kg	175/180	185/190
Refrigerant charge	kg	7.2	7.6
Part number		7SP062886	7SP062887
POWER SUPPLY 1~230V - 50 HZ			
Power supply side		Indoor & Outdoor	Outdoor
Power cable section	mm²	3x1.5 + 5x4.0	3x1.5 + 5x4.0
Fuse rating	A	6 + 20	6 + 25
Electrical connections	mm²	2x0.75	2x0.75
PIPE LINE			
Suction pipe diameter	inches	7/8"	7/8"
Liquid pipe diameter	inches	3/8"	3/8"
Max. length	m	120	120
Max. height	m	40	40

COMBINATIONS

Indoor unit	Compatible with outdoor unit
High wall	Monosplit
 <p>DED 76-95</p>	 <p>YED 76-95</p>

[MODEL NAME]

Page

INVERTER CASSETTE MONOSPLIT
MULTISPLIT → ONLY SIZES 9, 12 & 18

NEW



CCD



60

9
2.5 kW

12
3.5 kW

18
5 kW

24
7 kW

36
10 kW

48
12.5 kW

60 x 60



60 x 60



60 x 60



90 x 90



90 x 90

90 x 90

• Unique
• solutions

CCD 

Twin application

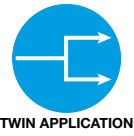

The twin application is used mainly in big open space where the total space area is controlled by one controller only for 2 units. Airwell twin design allows to connect two similar indoor units to one common outdoor unit. The two indoor units are working in a same mode and set up only once, one indoor unit used as master.

The most cost saving solution for single-area spaces:

- Simple installation by having one refrigerant and control system.
- Space saving by using one outdoor unit instead of two.
- Low cost installation.
- Simple control, one control station for big space.
- Option to control by wireless or wired controller.
- Ducted or cassette application.

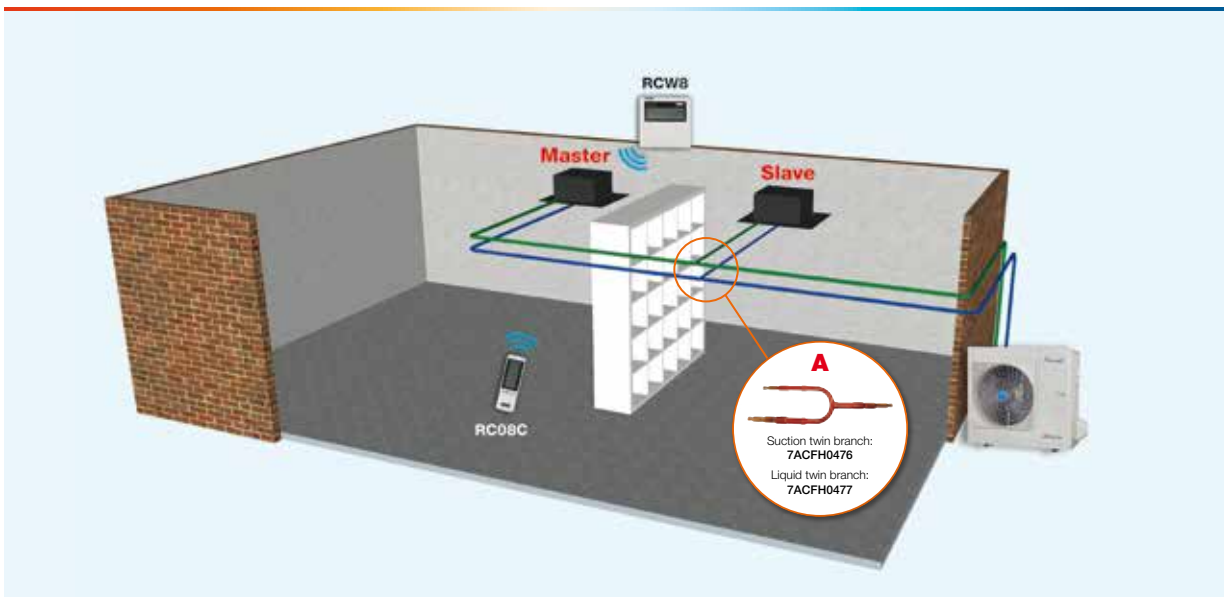

	Indoor units	Outdoor units
Twin system	CCD018 + CCD018	YMD036
	CCD024 + CCD024	YMD048

Tube & charge instructions	YMD036	YMD048
Pipe diameter (liquid-gas) (inches)	3/8"-5/8"	
Max. length (m)	30	50
Max. difference in branch length (m)	10	
Max. height drop between indoor units (m)	0.5	
Max. height drop between indoor and outdoor units (m)	20	
Max. branch length (m)	15	

MANDATORY ACCESSORIES

Accessory	Part number	Photo	Description	Function
Branch gas	7ACFH0476		Twin branch suction	Tube branch to collect all suction lines. Mandatory for Twin application.
Branch liquid	7ACFH0477		Twin branch liquid	Tube branch to collect all liquid lines. Mandatory for Twin application.

Monosplit DCI
Cooling & heating

CCD CASSETTE MONOSPLIT MULTISPLIT → Only sizes 9, 12 & 18



600x600 and 900x900

NEW **A++**  TWIN APPLICATION

+ PRODUCTS

- 360° flow.
- Auto swing.
- Twin application.
- Fresh air intake (for models 24 to 48).
- Water pump included.



RC08C RCW6 (optional) RCW8 (optional)

FEATURES

 DC INVERTER	 R410A FLUID	 ELECTRONIC EXPANSION VALVE	 AIR FILTER
 FRESH AIR (CCD 24-48)	 I FEEL	 MULTIFLOW 360°	 SLEEP MODE
 DIGITAL DISPLAY	 PROGRAMMABLE TIMER	 SELF DIAGNOSTIC	 LOW BATTERY INDICATION
 AUTO RESTART (MEMORY)	 REMOTE CONTROL LOCK	 AUTO MODE OPERATION	 AUTO FAN
 INTEGRATED WATER PUMP	 ALARM OUTPUT	 UNIT ON INPUT	 LOW AMBIENT COOLING
 LOW AMBIENT HEATING	 BMS COMPATIBLE	 WIFI	





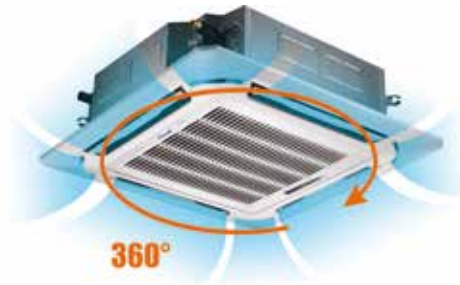

- DC Inverter and sine wave compressor drive technology.
- "I Feel" function with precise room temperature control.
- Available in 3PH from 10 kW.
- Centralized controller up to 64 units (optional).
- Sizes 9X, 12 & 18X can also match to multisplit outdoor unit (see dedicated part number page 76).
- Integrated water pump.

360 DEGREE FLOW WITH ROUND CORNERS



OPTIONS

Accessory	Part number	Photo	Function
Wired single control RCW6 (except size 9)	7ACEL1704		Mode, fan speed, real time, timer, temperature, weekly timer, swing and "I Feel".
Wired single control RCW8	7ACEL1706		Mode, fan speed, timer ON/OFF, temperature, swing and "I Feel".
Central controller RCW16	7ACEL1707		Controls up to 64 indoor units with individual setting failure codes indication, ON-OFF dry contact, last operation memory, Modbus.
BMS gateway	7ACEL1708		Maximum 1024 units could be connected (16 gateways).







All sizes except CCD 009X and 048

CCD TECHNICAL DATA

ONLY MULTI CONFIGURATION

Indoor unit		AWSI- CCD009X-N11	AWSI- CCD012-N11	AWSI- CCD018-N11	AWSI- CCD024-N11	AWSI- CCD036-N11	AWSI- CCD036-N11	AWSI- CCD048-N11
Outdoor units 1~230V - 50 Hz		-	AWAU- YMD012-H11	AWAU- YMD018-H11	AWAU- YMD024-H11	AWAU- YMD036-H11	-	-
Outdoor units 3~400V - 50 Hz		-	-	-	-	-	AWAU- YMD036-H13	AWAU- YMD048-H13
COOLING								
Rated power	kW	2.6 (0.8-3.3)	3.5 (0.8-4.4)	5.1 (0.8-6.1)	6.8 (1.2-8.2)	10.5 (2.9-12.0)	10.5 (2.9-12.0)	14.0 (4.0-16.1)
Pdesignc	kW		3.5	5.1	6.8	10.5	10.5	14.0
Rated power input	kW		0.9	1.579	2.105	4.008	4.008	5.344
SEER/Energy label			6.8/A++	6.3/A++	6.1/A++	6.1/A++	6.1/A++	5.6/A+
Operating limits	°C	-15°/50° Dry bulb						
HEATING								
Rated power	kW	2.9 (0.85-3.7)	4.1 (0.85-5.1)	5.6 (0.9-7.0)	7.6 (1.2-8.6)	11.2 (2.6-13.2)	11.2 (2.6-13.2)	15.5 (4.2-17.6)
Pdesignh (average climate)	kW		3.5	4.8	5.8	9.8	10.0	11.5
Pdesignh (warmer climate)	kW		3.6	5	5.8	10.5	10.5	11.6
Rated power input	kW		0.995	1.509	2.049	3.216	3.216	4.532
SCOP/Energy label (average climate)			4.0/A+	4.0/A+	4.0/A+	4.0/A+	4.0/A+	4.0/A+
SCOP/Energy Label (warmer climate)			5.1/A+++	5.1/A+++	5.1/A+++	5.1/A+++	5.1/A+++	5.1/A+++
Operating limits	°C	-15°/24° Dry bulb						
INDOOR UNIT								
Sound pressure level to 1 m (LS/MS/HS)	dB(A)	32/36/39	34/38/42	36/40/44	42/44/47	48/51/54	48/51/54	46/49/52
Sound power level	dB(A)	53	55	60	62	63	63	64
Airflow (LS/MS/HS)	m³/h	450/500/580	450/530/650	490/550/660	1300/1500/1700	1400/1600/1850	1400/1600/1850	1600/1800/2200
Dehumidification	l/h		1.5	2	2.5	3.8	3.8	4.5
Outline dimensions (WxHxD)	mm	570x270x570	570x270x570	570x270x570	840x245x840	840x245x840	840x245x840	840x287x840
Package dimensions (WxHxD)	mm	655x290x655	655x290x655	655x290x655	900x257x900	900x257x900	900x257x900	900x292x900
Net weight/Gross weight	kg	14.5/17.3	18.6/19	16.5/19	24/28	26.4/30.4	26.4/30.4	28/32.1
Part number		7SP042246X	7SP042247	7SP042248	7SP042249	7SP042250	7SP042250	7SP042251
FRAME								
Outline dimensions (WxHxD)	mm	647x50x647	647x50x647	647x50x647	950x55x950	950x55x950	950x55x950	950x55x950
Package dimensions (WxHxD)	mm	715x123x715	715x123x715	715x123x715	1035x90x1035	1035x90x1035	1035x90x1035	1035x90x1035
Net weight/Gross weight	kg	2.5/4.5	2.5/4.5	2.5/4.5	5/8	5/8	5/8	5/8
Part number frame		7ACVF0566	7ACVF0566	7ACVF0566	7ACVF0564	7ACVF0564	7ACVF0564	7ACVF0564
OUTDOOR UNIT								
Sound pressure level to 1 m	dB(A)		54	54	60	61	61	63
Sound power level	dB(A)		61	65	65	67	68	72
Airflow	m³/h		2000	2100	2700	4300	4300	6800
Compressor type			Rotary DCI	Rotary DCI	Twin Rotary DCI	Twin Rotary DCI	Twin Rotary DCI	Twin Rotary DCI
Refrigerant type/Ammount	kg		R410a/1.38	R410a/1.78	R410a/1.95	R410a/3.2	R410a/3.2	R410a/4.0
Outline dimensions (WxHxD)	mm		800x554x333	800x554x333	845x363x702	946x410x810	946x410x810	952x415x1333
Package dimensions (WxHxD)	mm		920x615x390	920x615x390	965x396x765	1090x500x865	1090x500x865	1095x500x1470
Net weight/Gross weight	kg		34.5/37.3	35.5/38.4	49/51.5	67.2/72.9	78.9/83.9	108.1/121.2
Part number 1~230V - 50 Hz			7SP062891	7SP062892	7SP062893	7SP062895	-	-
Part number 3~400V - 50 Hz			-	-	-	-	7SP062896	7SP062899
POWER SUPPLY 1~230V - 50 HZ								
Power supply side			Outdoor	Ind. & Out.	Ind. & Out.	Ind. & Out.	-	-
Power cable section	mm²		3x1.5	3x1.0+3x2.5	3x1.0+3x2.5	3x1.0+3x4.0	-	-
Fuse rating am	A		16	10+16	10+25	10+30	-	-
Electrical connections	mm²	4x1.0	4x1.0	2x0.5	2x0.5	2x0.5	-	-
POWER SUPPLY 3~400V - 50 HZ								
Power supply side		-	-	-	-	-	Ind. & Out.	Ind. & Out.
Power cable section	mm²	-	-	-	-	-	3x1.0+5x2.5	3x1.0+5x2.5
Fuse rating am	A	-	-	-	-	-	10+20	10+25
Electrical connections	mm²	-	-	-	-	-	2x0.5	2x0.5
PIPE LINE								
Suction pipe diameter	inches	3/8"	3/8"	1/2"	5/8"	5/8"	5/8"	5/8"
Liquid pipe diameter	inches	1/4"	1/4"	1/4"	3/8"	3/8"	3/8"	3/8"
Max. length	m		25	30	50	65	65	65
Max. height	m		10	20	25	30	30	30

COMBINATIONS

Indoor unit Cassette	Compatible with outdoor unit	
	Monosplit	Multisplit
<p>CCD 9X & CBD 18X</p> 		<p>YZZ</p> 
<p>CCD 12</p> 	<p>YMD</p> 	<p>YZZ</p> 

COMBINATIONS

Indoor unit Cassette	Compatible with outdoor unit
	Monosplit
<p>CCD 18-24-36</p> 	<p>YMD 18-24-36</p> 
<p>CCD 48</p> 	<p>YMD 48</p> 

Floor Ceiling Range

[MODEL NAME]

Page

CONSOLE DUAL FLOW
MONOSPLIT & MULTISPLIT

NEW



XBD



66

FLOOR CEILING MONOSPLIT

NEW

FCD



68

FLOOR CEILING MONOSPLIT
FOR LOW TEMPERATURE
ROOMS

FWDB



70

9 12 18 24 36 48 60
2.5 kW **3.5 kW** **5 kW** **7 kW** **10 kW** **12.5 kW** **16 kW**





NEW

A⁺⁺

+ PRODUCTS

- Dual flow.
- Operating down to -15°C in cooling and heating mode.
- 4 air outlet direction.
- Compact.
- Mono & multi application.



RC08C



RCW8
(optional)

FEATURES



FLEXY MATCH



DC INVERTER



R410A FLUID



ELECTRONIC EXPANSION VALVE



ANTIBACTERIA FILTER



I FEEL



SLEEP MODE



24 H PROGRAMMABLE TIMER



LOW BATTERY INDICATION



AUTO RESTART (MEMORY)



REMOTE CONTROL LOCK



DRY CONTACT ON/OFF



LOW AMBIENT COOLING



LOW AMBIENT HEATING



BMS COMPATIBLE (XBD 18)



WiFi



- "I Feel" function with precise room temperature control.
- Airflow direction control, up or down for comfort selection.
- Easy maintenance.
- Ideal solution for replacement of electric heaters: best comfort and save money.

2 AIR OUTLET WAYS



OPTIONS





Accessory	Part number	Photo	Function
Wired single control RCW8	7ACEL1706		Mode, fan speed, timer ON/OFF, temperature, swing and "I Feel".
Central controller RCW16 (only for size 18)	7ACEL1707		Controls up to 64 indoor units with individual setting failure codes indication, ON-OFF dry contact, last operation memory, Modbus.
BMS gateway	7ACEL1708		Maximum 1024 units could be connected (16 gateways). (For size 18 only).



Only XBD 012

XBD TECHNICAL DATA		ONLY MULTI CONFIGURATION		ONLY MULTI CONFIGURATION	
Indoor units		AWSI-XBD009X-N11	AWSI-XBD012-N11	AWSI-XAD018X-N11	
Outdoor units			AWAU-YMD012-H11		
COOLING					
Rated power	kW	2.6 (0.8-3.3)	3.5 (0.8-4.4)	4.7 (1.4-5.4)	
Pdesignc	kW		3.5		
Rated power input	kW		0.992		
SEER/Energy label			6.7/A++		
Operating limits	°C	-15°/50° Dry bulb			
HEATING					
Rated power	kW	2.9 (0.85-3.7)	3.8 (0.85-5.0)	5 (1.4-5.8)	
Pdesignh (average climate)	kW		3.6		
Pdesignh (warmer climate)	kW		3.6		
Rated power input	kW		0.995		
SCOP/Energy label (average climate)			4.0/A+		
SCOP/Energy label (warmer climate)			5.1/A+++		
Operating limits	°C	-15°/24° Dry bulb			
INDOOR UNIT					
Sound pressure level to 1 m (LS/MS/HS)	dB(A)	35/40/45	36/40/44	39/44/48	
Sound power level	dB(A)	56	58	59	
Airflow (LS/MS/HS/SS)	m³/h	450/580/680	360/470/550	520/650/740/820	
Dehumidification	l/h		1,5		
Outline dimensions (WxHxD)	mm	700x600x210	700x600x210	700x600x210	
Package dimensions (WxHxD)	mm	810x305x710	810x305x710	810x305x710	
Net weight/Gross weight	kg	13.5/18	15/20	15/20	
Part number		7SP071406X	7SP071407	7SP071405X	
OUTDOOR UNIT					
Sound pressure level to 1 m	dB(A)		54		
Sound power level	dB(A)		61		
Airflow	m³/h		2000		
Compressor type			Rotary DC Inverter		
Refrigerant type/Ammount	kg		R410a/1.38		
Outline dimensions (WxHxD)	mm		800x554x333		
Package dimensions (WxHxD)	mm		920x615x390		
Net weight/Gross weight	kg		34.5/37.3		
Part number			7SP062891		
POWER SUPPLY 1~230V - 50 HZ					
Power supply side		Outdoor	Outdoor	Indoor & Outdoor	
Power cable section	mm²		3x1.5		
Fuse rating am	A		16		
Electrical connections	mm²	4x1.0	4x1.0	3x0.5	
PIPE LINE					
Suction pipe diameter	inches	3/8"	3/8"	1/2"	
Liquid pipe diameter	inches	1/4"	1/4"	1/4"	
Max. length	m		25		
Max. height	m		10		

COMBINATIONS

Indoor unit	Compatible with outdoor unit	
	Monosplit	Multisplit
Console XBD 12 	YMD 	YCZ 
XBD 9X & XAD18X 		YCZ 



NEW

A⁺⁺

+ PRODUCTS

- Large scope air.
- Floor & ceiling installation.
- 4 air outlet direction.



RC08C



RCW6
(optional)



RCW8
(optional)

FEATURES



DC INVERTER



R410A FLUID



ELECTRONIC EXPANSION VALVE



ANTIBACTERIA FILTER



FRESH AIR



I FEEL



SLEEP MODE



DIGITAL DISPLAY



PROGRAMMABLE TIMER



SELF DIAGNOSTIC



LOW BATTERY INDICATION



AUTO RESTART (MEMORY)



REMOTE CONTROL LOCK



LEFT/RIGHT DRAIN CONNECTION



ALARM OUTPUT



UNIT ON INPUT



LOW AMBIENT COOLING



LOW AMBIENT HEATING



WATER PUMP CONNECTION (OPTION)



BMS COMPATIBLE



WiFi



- DC Inverter and sine wave compressor drive technology.
- "I Feel" function with precise room temperature control.
- Available in 3PH from 10 kW.
- Centralized controller up to 64 units (optional).

4 DIMENSIONAL AIRFLOWS FOR MAXIMUM COMFORT

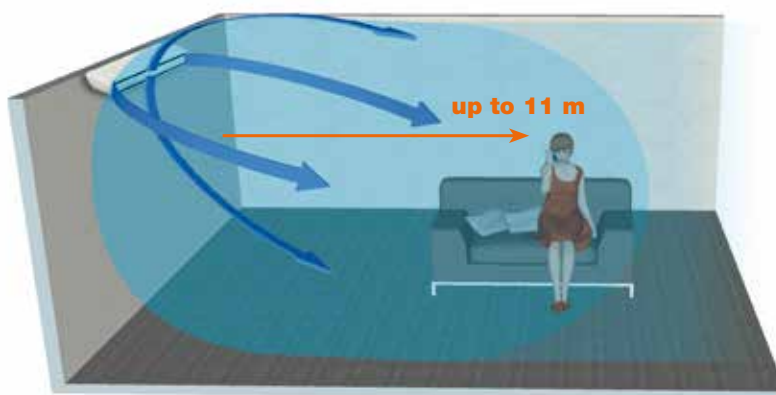

OPTIONS

Accessory	Part number	Photo	Function
Wired single control RCW6	7ACEL1704		Mode, fan speed, real time, timer, temperature, weekly timer, swing and "I Feel".
Wired single control RCW8	7ACEL1706		Mode, fan speed, timer ON/OFF, temperature, swing and "I Feel".
Central controller RCW16	7ACEL1707		Controls up to 64 indoor units with individual setting failure codes indication, ON-OFF dry contact, last operation memory, Modbus.
BMS gateway	7ACEL1708		Maximum 1024 units could be connected (16 gateways).



All sizes except FCD 048-060

FCD TECHNICAL DATA

Indoor units		AWSI-FCD018-N11	AWSI-FCD024-N11	AWSI-FCD036-N11	AWSI-FCD036-N11	AWSI-FCD048-N11	AWSI-FCD060-N11
Outdoor units 1-230V - 50 Hz		AWAU-YMD018-H11	AWAU-YMD024-H11	AWAU-YMD036-H11	-	-	-
Outdoor units 3-400V - 50 Hz - N		-	-	-	AWAU-YMD036-H13	AWAU-YMD048-H13	AWAU-YMD060-H13
COOLING							
Rated power	kW	5.1 (0.8-6.1)	6.8 (1.2-8.2)	10.5 (2.9-12.0)	10.5 (2.9-12.0)	14.0 (4.0-16.4)	16.0 (5.0-18.1)
Pdesignc	kW	5.1	6.8	10.5	10.5	14.0	16.0
Rated power input	kW	1.579	2.252	4.008	4.008	5.344	6.107
SEER/Energy label		6.5/A++	6.1/A++	6.3/A++	6.1/A++	6.1/A++	6.1/A++
Operating limits	°C	-15°/50° Dry bulb					
HEATING							
Rated power	kW	5.6 (0.9-7.0)	7.5 (1.2-8.6)	11.0 (2.6-13.2)	11.0 (2.6-13.2)	16.0 (4.4-18.4)	18.0 (5.3-20.5)
Pdesignh (average climate)	kW	4.8	5.8	10.2	10.2	11.6	12
Pdesignh (warmer climate)	kW	5.2	5.8	10.5	10.5	11.6	12.2
Rated power input	kW	1.466	2.072	3.039	3.039	4.969	5.96
SCOP/Energy label (average climate)		4.0/A+	4.0/A+	4.0/A+	4.0/A+	4.0/A+	4.0/A+
SCOP/Energy label (warmer climate)		5.1/A+++	5.1/A+++	5.1/A+++	5.1/A+++	5.1/A+++	5.1/A+++
Operating limits	°C	-15°/24° Dry bulb					
INDOOR UNIT							
Sound pressure level to 1 m (LS/MS/HS)	dB(A)	38/41/44	44/49/52	43/49/52	43/49/52	46/51/54	46/51/57
Sound power level	dB(A)	57	63	63	63	66	69
Airflow (LS/MS/HS)	m³/h	700/800/900	850/1050/1180	1400/1770/2050	1400/1770/2050	1400/1800/2100	1280/1660/2250
Dehumidification	l/h	1.5	2.2	3.1	3.1	5	5.5
Outline dimensions (WxHxD)	mm	1068x235x675	1068x235x675	1650x235x675	1650x235x675	1650x235x675	1650x235x675
Package dimensions (WxHxD)	mm	1145x313x755	1145x313x755	1725x313x755	1725x313x755	1725x313x755	1725x313x755
Net weight/Gross weight	kg	25.8/30.6	25/30	40.3/46.9	40.3/46.9	38.2/44.6	40.5/47
Part number		7SP012231	7SP012232	7SP012233	7SP012233	7SP012234	7SP012235
OUTDOOR UNIT							
Sound pressure level to 1 m	dB(A)	54	60	61	61	63	63
Sound power level	dB(A)	65	65	67	68	72	75
Airflow	m³/h	2100	2700	4300	4300	6800	7200
Compressor type		Rotary DCI	Twin Rotary DCI	Twin Rotary DCI	Twin Rotary DCI	Twin Rotary DCI	Twin Rotary DCI
Refrigerant type/Ammount	kg	R410a/1.78	R410a/1.95	R410a/3.2	R410a/3.2	R410a/4.0	R410a/4.3
Outline dimensions (WxHxD)	mm	800x554x333	845x702x363	946x810x410	946x810x410	952x1333x415	952x1333x415
Package dimensions (WxHxD)	mm	920x615x390	965x765x396	1090x865x500	1090x865x500	1095x1470x500	1095x1470x500
Net weight/Gross weight	kg	35.5/38.4	49/51.5	67.2/72.9	78.9/83.9	108.1/121.2	112.8/126
Part number 1-230V - 50 Hz		7SP062892	7SP062893	7SP062895	-	-	-
Part number 3-400V - 50 Hz - N		-	-	-	7SP062896	7SP062899	7SP062900
POWER SUPPLY 1-230V - 50 HZ							
Power supply side		Indoor & Outdoor	Indoor & Outdoor	Indoor & Outdoor	-	-	-
Power cable section	mm²	3x1.0+3x2.5	3x1.0+3x2.5	3x1.0+3x4.0	-	-	-
Fuse rating am	A	10+16	10+25	10+30	-	-	-
Electrical connections	mm²	2x0.5	2x0.5	2x0.5	-	-	-
POWER SUPPLY 3-400V - 50 HZ - N							
Power supply side		-	-	-	Indoor & Outdoor	Indoor & Outdoor	Indoor & Outdoor
Power cable section	mm²	-	-	-	3x1.0+5x2.5	3x1.0+5x2.5	3x1.0+5x2.5
Fuse rating am	A	-	-	-	10+20	10+25	10+25
Electrical connections	mm²	-	-	-	2x0.5	2x0.5	2x0.5
PIPE LINE							
Suction pipe diameter	inches	1/2"	5/8"	5/8"	5/8"	5/8"	5/8"
Liquid pipe diameter	inches	1/4"	3/8"	3/8"	3/8"	3/8"	3/8"
Max. length	m	30	50	65	65	65	65
Max. height	m	20	25	30	30	30	30

COMBINATIONS

Indoor unit	Compatible with outdoor unit
High wall FCD 18-24-36 	Monosplit YMD 18-24-36 
FCD 48-60 	YMD 48-60 



+ PRODUCTS

- Minimum ambient temperature **12°C** inside. Operation down to **-10°C** outdoor.
- Application for wine cellar, garbage room, preparation rooms...



RCW6

FEATURES

DC INVERTER	R410A FLUID	ELECTRONIC EXPANSION VALVE	ANTIBACTERIA FILTER
FRESH AIR	I FEEL	SLEEP MODE	DIGITAL DISPLAY
SELF DIAGNOSTIC	AUTO RESTART (MEMORY)	REMOTE CONTROL LOCK	LEFT/RIGHT DRAIN CONNECTION
ALARM OUTPUT	DRY CONTACT ON/OFF	LOW AMBIENT COOLING	LOW AMBIENT HEATING
WATER PUMP CONNECTION (OPTION)	BMS COMPATIBLE		



- Cooling & heating operation mode.
- DC Inverter and sine wave compressor drive technology.
- “I Feel” function with precise room temperature control.
- Fuzzy logic to control compressor by outdoor fan and electronic expansion valve in extreme low operation temperature.
- Possibility to reverse dry contact: normally open/normally closed.



OPTIONS

Accessory	Part number	Photo	Function
Central controller RCW16	7ACE1707		Controls up to 64 indoor units with individual setting failure codes indication, ON-OFF dry contact, last operation memory, Modbus.
BMS gateway	7ACE1708		Maximum 1024 units could be connected (16 gateways).



FWDB TECHNICAL DATA

Indoor units		AWSI-FWDB018-N11	AWSI-FWDB024-N11
Outdoor units 1~230V - 50 Hz		AWAU-YLD018-H11	AWAU-YLD024-H11
COOLING			
Rated power	kW	5.3 (1.5~6.4)	7.2 (2.0~7.8)
Pdesignc	kW	5.3	7.2
Rated power input	kW	1.63	2.24
SEER/Energy label		6.1/A++	6.4/A++
Operating limits	°C	-10°/50° Dry bulb	
HEATING			
Rated power	kW	5.9 (1.6~7.0)	7.8 (2.0~8.6)
Pdesignh (average climate)	kW	5.3	7.8
Pdesignh (warmer climate)	kW	5.3	7.8
Rated power input	kW	1.49	2.10
SCOP/Energy label (average climate)		3.8/A	3.9/A
SCOP/Energy label (warmer climate)		4.8/A++	4.6/A++
Operating limits	°C	-15°/24° Dry bulb	
Power @ -10°C	kW	4.3	7
Power @ -15°C	kW	3.7	6
INDOOR UNIT			
Sound pressure level to 1 m (LS/MS/HS)	dB(A)	38/41/44	46/50/52
Sound power level	dB(A)	60	63
Airflow (LS/MS/HS)	m³/h	600/750/900	1100/1250/1400
Dehumidification	l/h	2	2.3
Outline dimensions (WxHxD)	mm	1068x675x235	1068x675x235
Package dimensions (WxHxD)	mm	1145x755x313	1145x755x313
Net weight/Gross weight	kg	25/31.5	25/30
Part number		7SP012227	7SP012228
OUTDOOR UNIT			
Sound pressure level to 1 m	dB(A)	55	57
Sound power level	dB(A)	65	69
Airflow	m³/h	2500	3500
Compressor type		Rotary DCI	Twin Rotary DCI
Outline dimensions (WxHxD)	mm	845x700x320	900x860x315
Package dimensions (WxHxD)	mm	965x755x395	1043x915x395
Net weight/Gross weight	kg	46/50	59/63
Part number 1~230V - 50 Hz		7SP062822	7SP062823
POWER SUPPLY 1~230V - 50 HZ			
Power supply side		Indoor & Outdoor	Indoor & Outdoor
Power cable section	mm²	3x1.0+3x2.5	3x1.0+3x2.5
Fuse rating am	A	10+16	10+20
Electrical connections	mm²	3x0.5	3x0.5
PIPE LINE			
Suction pipe diameter	inches	1/2"	5/8"
Liquid pipe diameter	inches	1/4"	3/8"
Max. length	m	30	50
Max. height	m	20	25

COMBINATIONS

Indoor unit	Compatible with outdoor unit
Floor ceiling	Monosplit
FWDB	YLD
	

Twin & Multisplit DCI Range Combination Table

[MODEL NAME]			kW	Btu/h	Max. num. of indoors	Page		
MULTISPLIT	TWIN APPLICATION	UPGRADE			10-14	48 000 60 000	2	74
	YCZ2-18	UPGRADE			5.3	18 000	2	76 & 80
	YCZ3-27	UPGRADE			7.8	26 500	3	76 & 80
	YCZ4-30	UPGRADE			8.5	30 000	4	76 & 81
	YCZ5-42	UPGRADE			12.3	42 000	5	76 & 82

[INDOOR UNITS]

**High wall
HND**



**High wall
HKD**



**Ducted medium static
pressure DID**



**Cassette
CCD**



**Console
XBD**



18+18/24+24

18+18/24+24



Sizes 7/9/12/18



Sizes 9/12/18



Size 12



Sizes 9X/12/18X



Sizes 9X/12/18X



Sizes 7/9/12/18



Sizes 9/12/18



Size 12



Sizes 9X/12/18X



Sizes 9X/12/18X



Sizes 7/9/12/18/24



Sizes 9/12/18/24



Size 12



Sizes 9X/12/18X



Sizes 9X/12/18X



Sizes 7/9/12/18/24



Sizes 9/12/18/24



Size 12



Sizes 9X/12/18X



Sizes 9X/12/18X



Unique
solutions

Twin application



Twin application

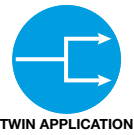

The twin application is used mainly in big open space where the total space area is controlled by one controller only for 2 units. Airwell twin design allows to connect two similar indoor units to one common outdoor unit. The two indoor units are working in a same mode and set up only once, one indoor unit used as master.

The most cost saving solution for single-area spaces:

- Simple installation by having one refrigerant and control system.
- Space saving by using one outdoor unit instead of two.
- Low cost installation.
- Simple control, one control station for big space.
- Option to control by wireless or wired controller.
- Ducted or cassette application.

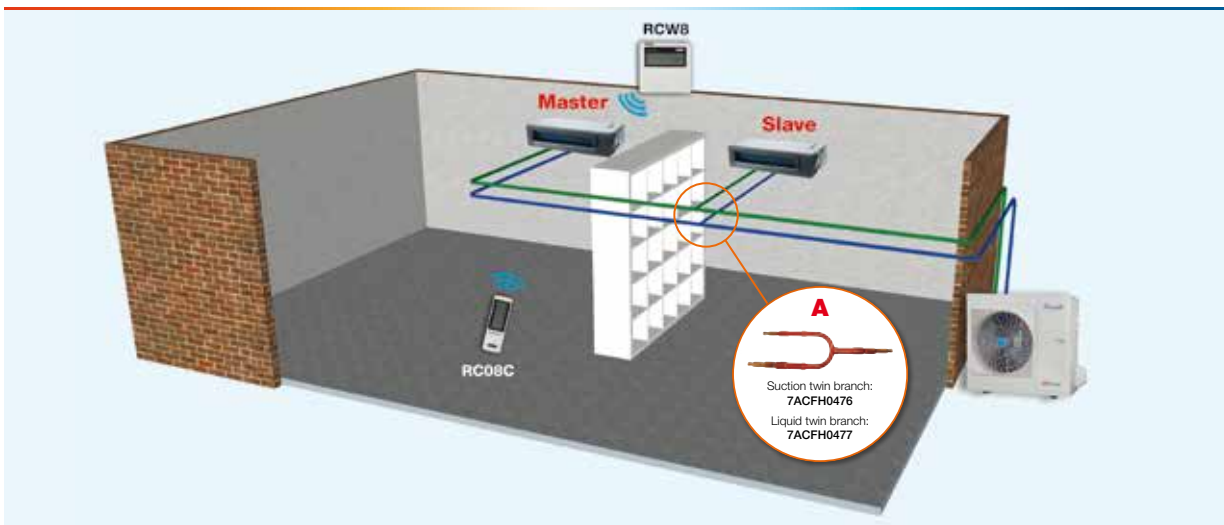

	Indoor units	Outdoor units
Twin system	CCD018 + CCD018	YMD036
	DID018 + DID018	
	CCD024 + CCD024	YMD048
	DID024 + DID024	

Tube & charge instructions	YMD036	YMD048
Pipe diameter (liquid-gas) (inches)	3/8"-5/8"	
Max. length (m)	30	50
Max. difference in branch length (m)	10	
Max. height drop between indoor units (m)	0.5	
Max. height drop between indoor and outdoor units (m)	20	
Max. branch length (m)	15	

TWIN APPLICATION WITH			Page
DID	Ducted medium static pressure monosplit		52
CCD	Inverter cassette monosplit/multisplit → only size 9		60



UPGRADE



+ PRODUCTS

- Efficient.
- Competitive.
- Flexible.

FEATURES



YCZ2-18



YCZ3-27
YCZ4-30
YCZ5-42

- DC Inverter and sine wave compressor drive technology.
- Match with high wall, ducted, cassette and console indoor units.
- Same indoor for multi and single application (except for CCD009X, CBD018X, XBD009X and XAD018X).
- Option to connect limited indoor units (total capacity >100% of rated capacity) and extend after installation.
- Design for long tubing distance installation.
- 2 digit display to check running parameters.

COMPATIBLE WITH



COMBINATIONS

Sizes	HND	HKD	DID	CCD	XBD
7	AWSI-HND007-N11 7SP023048	-	-	-	-
9	AWSI-HND009-N11 7SP023034	AWSI-HKD009-N11 7SP023030	-	AWSI-CCD009X-N11 7SP042246X *	AWSI-XBD009X-N11 7SP071406X *
	-	-	-	Part number frame 7ACVF0566	-
12	AWSI-HND012-N11 7SP023035	AWSI-HKD012-N11 7SP023031	AWSI-DID012-N11 7SP032165	AWSI-CCD012-N11 7SP042247	AWSI-XBD012-N11 7SP071407
	-	-	-	Part number frame 7ACVF0566	-
18	AWSI-HND018-N11 7SP023036	AWSI-HKD018-N11 7SP023032	-	AWSI-CBD018X-N11 7SP042239X *	AWSI-XAD018X-N11 7SP071404X *
	-	-	-	Part number frame 7ACVF0566	-
24	AWSI-HND024-N11 7SP023037	AWSI-HKD024-N11 7SP023033	-	-	-

* Dedicated part number for multisplit application.



Depending on combination

YCZ TECHNICAL DATA

Outdoor units			AWAU-YCZ218-H11	AWAU-YCZ327-H11	AWAU-YCZ430-H11	AWAU-YCZ542-H11
OUTDOOR UNIT						
Cooling	Rated power	kW	5.3 (1.8-6.3)	7.8 (2.7-8.7)	8.5 (2.8-9.2)	12.3 (3.0-13.5)
	Pdesignc	kW	5.3	7.8	8.5	12.3
	Rated power input	kW	1.419	2.422	2.64	3.82
	SEER/Energy label		7.4/A++ *	6.6/A++ *	6.6/A++ *	6.6/A++ *
	Operating limits	°C	-15°/50° Dry bulb			
Heating	Rated power	kW	6.0 (2.0-6.5)	8.5 (2.8-9.2)	9.0 (2.8-10.0)	12.3 (3.0-14.0)
	Pdesignh (average climate)	kW	5.3	6.5	7.2	9.6
	Pdesignh (warmer climate)	kW	5.5	6.6	7.3	9.8
	Rated power input	kW	1.657	2.348	2.486	3.407
	SCOP/Energy label (average climate)		4.1/A+	4.0/A	3.9/A	3.8/A
	SCOP/Energy label (warmer climate)		5.1/A+++	5.1/A+++	5.1/A+++	4.6/A++
	Operating limits	°C	-15°/24° Dry bulb			
	Power @ -10°C	kW	4.5	6.5	6.6	8.4
	Power @ -15°C	kW	4.0	5.7	5.8	7.2
Sound pressure level to 1 m	dB(A)	55	58	58	60	
Sound power level	dB(A)	63	67	67	70	
Airflow	m³/h	2500	3500	3500	5500	
Compressor type		Twin Rotary DC Inverter	Twin Rotary DC Inverter	Twin Rotary DC Inverter	Twin Rotary DC Inverter	
Refrigerant type/Ammount	kg	R410a/2.0	R410a/2.4	R410a/2.4	R410a/3.6	
Outline dimensions (WxHxD)	mm	845x702x363	946x810x410	946x810x410	946x810x410	
Package dimensions (WxHxD)	mm	965x755x395	1090x865x500	1090x865x500	1090x865x500	
Net weight/Gross weight	kg	48/52	68/73	70/75	76/81	
Part number		7SP091170	7SP091171	7SP091172	7SP091173	
POWER SUPPLY 1~230V - 50 HZ						
Power supply side		Outdoor	Outdoor	Outdoor	Outdoor	
Power cable section	mm²	3x2.5	3x2.5	3x2.5	3x4.0	
Fuse rating am	A	25	25	25	32	
Electrical connections	mm²	2 (4x1.0)	3 (4x1.0)	4 (4x1.0)	5 (4x1.0)	
PIPE LINE						
Suction pipe diameter	inches	2x3/8"	3x3/8"	4x3/8"	4x3/8"+1/2"	
Liquid pipe diameter	inches	2x1/4"	3x1/4"	4x1/4"	5x1/4"	
Max. length	m	30	45	60	80	
Max. length per circuit	m	20	25	30	30	
Max. height between indoor and outdoor units	ODU higher than IDU	m	10	10	10	10
	ODU lower than IDU	m	15	15	15	15
Max. height between indoor units	m	10	10	10	10	

* A++ for HND 9 x 2/HND 9 x 3/HND 9 x 4/HKD 9 x 3 combinations.

Nota: Pipe adaptor (3/8" → 1/2") needs to be fixed on the gas valve of outdoor unit when connecting 18K indoor unit. This adaptor can be supplied by Airwell (ref. 1511160000297).

Pipe adaptor 3/8" → 5/8" needs to be fixed on the gas valve and a pipe adaptor 1/4" → 3/8" on the liquid valve of outdoor unit when connecting 24K indoor unit.

HIGH WALL
HND 7/9/12/18/24



HND INDOOR UNITS TECHNICAL DATA

Indoor units		AWSI-HND007-N11	AWSI-HND009-N11	AWSI-HND012-N11	AWSI-HND018-N11	AWSI-HND024-N11
Cooling rated power	kW	2.05 (1.0-2.7)	2.65 (1.2-3.3)	3.54 (1.3-4.4)	5.3 (1.8-6.1)	7.05 (2.7-7.8)
Heating rated power	kW	2.34 (0.85-3.0)	2.8 (0.85-3.7)	3.7 (1.2-4.8)	5.5 (1.4-6.7)	7.3 (1.6-8.7)
Sound pressure level to 1 m (VL/LS/MS/HS)	dB(A)	21/25/31/35	21/25/31/35	21/26/32/36	23/30/36/42	28/34/41/46
Sound power level	dB(A)	53	53	53	62	64
Airflow (LS/MS/HS)	m³/h	280/400/460	280/400/460	320/460/550	490/620/830	700/950/1050
Dehumidification	l/h	0.8	1.0	1.2	1.7	2.3
Outline dimensions (WxHxD)	mm	750x280x198	750x280x198	835x280x198	990x315x218	1186x343x258
Package dimensions (WxHxD)	mm	830x355x270	830x355x270	910x355x270	1065x300x400	1265x420x340
Net weight/Gross weight	kg	7.7/9.9	7.8/9.9	8.7/11.2	11.8/15	15.6/20.6
PIPE LINE						
Suction pipe diameter	inches	3/8"	3/8"	3/8"	1/2"	5/8"
Liquid pipe diameter	inches	1/4"	1/4"	1/4"	1/4"	3/8"
Part number		7SP023048	7SP023034	7SP023035	7SP023036	7SP023037

HIGH WALL
HKD 9/12/18/24



HKD INDOOR UNITS TECHNICAL DATA

Indoor units		AWSI-HKD009-N11	AWSI-HKD012-N11	AWSI-HKD018-N11	AWSI-HKD024-N11
Cooling rated power	kW	2.65 (1.2-3.3)	3.54 (1.3-4.4)	5.0 (1.8-6.1)	6.8 (2.7-7.8)
Heating rated power	kW	2.8 (0.85-3.7)	3.5 (1.2-4.8)	5.0 (1.4-6.7)	7.5 (1.6-8.7)
Sound pressure level to 1 m (VL/LS/MS/HS)	dB(A)	22/31/35/38	23/29/32/36	23/29/33/36	31/37/40/43
Sound power level	dB(A)	54	53	57	63
Airflow (VL/LS/MS/HS)	m³/h	230/320/380/430	310/390/430/480	360/460/540/610	650/820/890/960
Dehumidification	l/h	1.0	1.2	1.7	2.4
Outline dimensions (WxHxD)	mm	715x250x188	800x275x188	940x275 x205	1045x315x235
Package dimensions (WxHxD)	mm	775x324x260	865x350x265	1015x265x350	1135x315x395
Net weight/Gross weight	kg	6.5/8.2	7.4/9.5	9/12.2	12/15.2
PIPE LINE					
Suction pipe diameter	inches	3/8"	3/8"	1/2"	5/8"
Liquid pipe diameter	inches	1/4"	1/4"	1/4"	3/8"
Part number		7SP023030	7SP023031	7SP023032	7SP023033

DUCTED MEDIUM STATIC PRESSURE DID 12



CASSETTE CCD 9X/12/18X



DID & CCD INDOOR UNITS TECHNICAL DATA

Indoor unit		AWSI-DID012-N11	AWSI-CCD009X-N11	AWSI-CCD012-N11	AWSI-CBD018X-N11
Cooling rated power	kW	3.5 (0.6-4.4)	2.6 (0.8-3.3)	3.5 (0.8-4.4)	5.1 (0.8-6.1)
Heating rated power	kW	3.8 (0.6-5.0)	2.9 (0.85-3.7)	4.1 (0.85-5.1)	5.6 (0.9-7.0)
Sound pressure level to 1 m (LS/MS/HS)	dB(A)	27/31/35	32/36/39	34/38/42	36/40/44
Sound power level	dB(A)	57	53	55	60
Airflow (LS/MS/HS)	m³/h	450/580/680	450/500/580	450/530/650	490/550/660
External static pressure	Pa	25 (0-45)			
Dehumidification	l/h	1.5	0.9	1.5	2
Outline dimensions (WxHxD)	mm	700x210x635	570x270x570	570x270x570	570x270x570
Package dimensions (WxHxD)	mm	915x290x655	655x290x655	655x290x655	655x290x655
Net weight/Gross weight	kg	18.4/22.7	14.5/17.3	16/18,6	16.5/19
FRAME					
Outline dimensions (WxHxD)	mm		647x50x647	647x50x647	647x50x647
Package dimensions (WxHxD)	mm		715x123x715	715x123x715	715x123x715
Net weight/Gross weight	kg		2.5/4.5	2.5/4.5	2.5/4.5
Part number frame			7ACVF0566	7ACVF0566	7ACVF0566
PIPE LINE					
Suction pipe diameter	inches	3/8"	3/8"	3/8"	1/2"
Liquid pipe diameter	inches	1/4"	1/4"	1/4"	1/4"
Part number		7SP032165	7SP042246X	7SP042247	7SP042239X

CONSOLE XBD 9X/12/18X



XBD INDOOR UNITS TECHNICAL DATA

Indoor units		AWSI-XBD009X-N11	AWSI-XBD012-N11	AWSI-XAD018X-N11
Cooling rated power	kW	2.6 (0.8-3.3)	3.5 (0.8-4.4)	4.7 (1.4-5.4)
Heating rated power	kW	2.9 (0.85-3.7)	3.8 (0.85-5.0)	5 (1.4-5.8)
Sound pressure level to 1 m (LS/MS/HS)	dB(A)	35/40/45	36/40/44	39/44/48
Sound power level	dB(A)	56	58	59
Airflow (LS/MS/HS/SS)	m³/h	450/580/680	360/470/550	520/650/740/820
Dehumidification	l/h	0.9	1.5	3.0
Outline dimensions (WxHxD)	mm	700x600x210	700x600x210	700x600x210
Package dimensions (WxHxD)	mm	810x305x710	810x305x710	810x305x710
Net weight/Gross weight	kg	13.5/18	15/20	15/20
PIPE LINE				
Suction pipe diameter	inches	3/8"	3/8"	1/2"
Liquid pipe diameter	inches	1/4"	1/4"	1/4"
Part number		7SP071406X	7SP071407	7SP071405X

COMPATIBLE WITH

HIGH WALL
HND 7/9/12/18/24



HIGH WALL
HKD 9/12/18/24



DUCTED MEDIUM STATIC
PRESSURE DID 12



CASSETTE
CCD 9X/12/18X



CONSOLE
XBD 9X/12/18X



YCZ2-18 RESIDENTIAL MULTISPLIT DUO

Indoor units combinations	COOLING									HEATING								
	Rated power (kW)		Total power (kW)			Total input power (kW)			EER/ Energy label	Rated power (kW)		Total power (kW)			Total input power (kW)			COP/ Energy label
	Unit A	Unit B	Rated	Min.	Max.	Rated	Min.	Max.		Unit A	Unit B	Rated	Min.	Max.	Rated	Min.	Max.	
7+7	2.05	2.05	4.10	1.42	5.40	1.25	0.44	1.80	3.28/A	2.34	2.34	4.68	1.56	6.00	1.38	0.46	1.67	3.39/C
7+9	2.05	2.65	4.70	1.63	6.00	1.44	0.50	1.99	3.26/A	2.34	2.80	5.14	1.72	6.50	1.50	0.50	1.81	3.43/B
7+12	1.95	3.35	5.30	1.80	6.20	1.55	0.55	2.16	3.42/A	2.21	3.79	6.00	2.00	6.50	1.62	0.58	1.81	3.70/A
7+18	1.48	3.82	5.30	1.80	6.30	1.55	0.55	2.16	3.42/A	1.68	4.32	6.00	2.00	6.70	1.62	0.58	1.89	3.70/A
9+9	2.65	2.65	5.30	1.80	6.20	1.55	0.55	2.16	3.42/A	3.00	3.00	6.00	2.00	6.50	1.66	0.58	1.81	3.62/A
9+12	2.27	3.03	5.30	1.80	6.30	1.55	0.55	2.16	3.42/A	2.57	3.43	6.00	2.00	6.50	1.66	0.58	1.81	3.62/A
9+18	1.77	3.53	5.30	1.80	6.30	1.55	0.55	2.16	3.42/A	2.00	4.00	6.00	2.00	6.70	1.66	0.58	1.89	3.62/A
12+12	2.65	2.65	5.30	1.80	6.30	1.55	0.55	2.16	3.42/A	3.00	3.00	6.00	2.00	6.70	1.66	0.58	1.89	3.62/A

Based on wall mounted combination



YCZ3-27 RESIDENTIAL MULTISPLIT TRIO

Indoor units combinations	COOLING									HEATING										
	Rated power (kW)			Total power (kW)			Total input power (kW)			EER/ Energy label	Rated power (kW)			Total power (kW)			Total input power (kW)			COP/ Energy label
	Unit A	Unit B	Unit C	Rated	Min.	Max.	Rated	Min.	Max.		Unit A	Unit B	Unit C	Rated	Min.	Max.	Rated	Min.	Max.	
12+12	3.54	3.54	-	7.08	2.45	8.70	2.17	0.69	2.90	3.26/A	3.70	3.70	-	7.40	2.44	9.20	2.05	0.67	2.70	3.61/A
9+18	2.65	5.00	-	7.65	2.65	8.70	2.37	0.75	2.90	3.23/A	2.80	5.50	-	8.30	2.73	9.20	2.30	0.74	2.70	3.61/A
12+18	3.12	4.68	-	7.80	2.70	8.74	2.42	0.76	2.91	3.22/A	3.40	5.10	-	8.50	2.80	9.25	2.35	0.76	2.71	3.62/A
18+18	3.90	3.90	-	7.80	2.70	8.83	2.42	0.76	2.94	3.22/A	4.25	4.25	-	8.50	2.80	9.34	2.35	0.76	2.74	3.62/A
7+7+18	1.71	1.71	4.38	7.80	2.70	8.77	2.42	0.76	2.92	3.22/A	1.86	1.86	4.78	8.50	2.80	9.28	2.35	0.70	2.72	3.62/A
7+9+12	1.95	2.51	3.34	7.80	2.70	8.71	2.42	0.76	2.90	3.22/A	2.13	2.73	3.64	8.50	2.80	9.22	2.35	0.70	2.71	3.62/A
7+9+18	1.61	2.06	4.13	7.80	2.70	8.80	2.42	0.76	2.93	3.22/A	1.75	2.25	4.50	8.50	2.80	9.31	2.35	0.70	2.73	3.62/A
7+12+12	1.76	3.02	3.02	7.80	2.70	8.76	2.42	0.76	2.92	3.22/A	1.92	3.29	3.29	8.50	2.80	9.26	2.35	0.70	2.72	3.62/A
7+12+18	1.48	2.53	3.79	7.80	2.70	8.85	2.42	0.76	2.95	3.22/A	1.61	2.76	4.13	8.50	2.80	9.35	2.35	0.70	2.74	3.62/A
9+9+9	2.60	2.60	2.60	7.80	2.70	8.70	2.42	0.76	2.90	3.22/A	2.83	2.83	2.83	8.50	2.80	9.20	2.35	0.70	2.70	3.62/A
9+9+12	2.34	2.34	3.12	7.80	2.70	8.74	2.42	0.76	2.91	3.22/A	2.55	2.55	3.40	8.50	2.80	9.25	2.35	0.70	2.71	3.62/A
9+9+18	1.95	1.95	3.90	7.80	2.70	8.83	2.42	0.76	2.94	3.22/A	2.13	2.13	4.24	8.50	2.80	9.34	2.35	0.70	2.74	3.62/A
9+12+12	2.12	2.84	2.84	7.80	2.70	8.79	2.42	0.76	2.93	3.22/A	2.32	3.09	3.09	8.50	2.80	9.29	2.35	0.70	2.73	3.62/A
9+12+18	1.80	2.40	3.60	7.80	2.70	8.87	2.42	0.76	2.96	3.22/A	1.96	2.62	3.92	8.50	2.80	9.38	2.35	0.70	2.75	3.62/A
12+12+12	2.60	2.60	2.60	7.80	2.70	8.83	2.42	0.76	2.94	3.22/A	2.83	2.83	2.83	8.50	2.80	9.34	2.35	0.70	2.74	3.62/A

Based on wall mounted combination



YCZ4-30 RESIDENTIAL MULTISPLIT QUATTRO

Indoor units combinations	COOLING											HEATING										
	Rated power (kW)				Total power (kW)			Total input power (kW)			EER/ Energy label	Rated power (kW)				Total power (kW)			Total input power (kW)			COP/ Energy label
	Unit A	Unit B	Unit C	Unit D	Rated	Min.	Max.	Rated	Min.	Max.		Unit A	Unit B	Unit C	Unit D	Rated	Min.	Max.	Rated	Min.	Max.	
7+24	1.92	6.58	-	-	8.50	2.70	9.80	2.64	0.77	3.40	3.22/A	2.03	6.97	-	-	9.00	2.86	10.00	2.61	0.94	3.19	3.45/B
12+12	3.54	3.54	-	-	7.08	2.25	7.60	2.12	0.64	2.58	3.34/A	3.70	3.70	-	-	7.40	2.30	9.60	2.14	0.72	2.93	3.46/B
9+18	2.65	5.00	-	-	7.65	2.43	9.40	2.33	0.69	3.20	3.28/A	2.80	5.50	-	-	8.30	2.58	10.00	2.40	0.79	3.05	3.46/B
9+24	2.32	6.18	-	-	8.50	2.70	9.80	2.64	0.77	3.40	3.22/A	2.45	6.55	-	-	9.00	2.86	10.00	2.61	0.94	3.19	3.45/B
12+18	3.40	5.10	-	-	8.50	2.70	9.40	2.64	0.77	3.40	3.22/A	3.40	5.10	-	-	8.50	2.64	10.00	2.46	0.81	3.05	3.46/B
12+24	2.83	5.67	-	-	8.50	2.70	9.80	2.64	0.77	3.40	3.22/A	3.00	6.00	-	-	9.00	2.86	10.00	2.61	0.94	3.19	3.45/B
18+18	4.25	4.25	-	-	8.50	2.70	9.80	2.64	0.77	3.40	3.22/A	4.50	4.50	-	-	9.00	2.80	10.00	2.61	0.85	3.05	3.45/B
7+7+18	1.86	1.86	4.78	-	8.50	2.70	9.80	2.64	0.77	3.13	3.22/A	1.97	1.97	5.06	-	9.00	2.80	10.00	2.55	0.79	3.05	3.53/B
7+7+24	1.57	1.57	5.36	-	8.50	2.70	9.88	2.64	0.77	3.16	3.22/A	1.66	1.66	5.68	-	9.00	2.86	10.00	2.55	0.88	3.19	3.53/B
7+9+12	2.06	2.65	3.53	-	8.24	2.62	9.80	2.54	0.75	3.13	3.24/A	2.21	2.84	3.79	-	8.84	2.75	10.00	2.50	0.78	3.05	3.54/B
7+9+18	1.75	2.25	4.50	-	8.50	2.70	9.80	2.64	0.77	3.13	3.22/A	1.85	2.38	4.77	-	9.00	2.80	10.00	2.55	0.79	3.05	3.53/B
7+12+12	1.92	3.29	3.29	-	8.50	2.70	9.80	2.64	0.77	3.13	3.22/A	2.03	3.48	3.49	-	9.00	2.80	10.00	2.55	0.79	3.05	3.53/B
7+12+18	1.61	2.76	4.13	-	8.50	2.70	9.80	2.64	0.77	3.14	3.22/A	1.70	2.92	4.38	-	9.00	2.80	10.04	2.55	0.79	3.06	3.53/B
9+9+9	2.65	2.65	2.65	-	7.95	2.53	9.50	2.44	0.72	3.00	3.26/A	2.83	2.83	2.83	-	8.50	2.64	10.00	2.40	0.75	3.05	3.54/B
9+9+12	2.55	2.55	3.40	-	8.50	2.70	9.80	2.64	0.77	3.13	3.22/A	2.70	2.70	3.60	-	9.00	2.80	10.00	2.55	0.79	3.05	3.53/B
9+9+18	2.13	2.13	4.24	-	8.50	2.70	9.80	2.64	0.77	3.13	3.22/A	2.25	2.25	4.50	-	9.00	2.80	10.00	2.55	0.79	3.05	3.53/B
9+12+12	2.32	3.09	3.09	-	8.50	2.70	9.80	2.64	0.77	3.13	3.22/A	2.46	3.27	3.27	-	9.00	2.80	10.00	2.55	0.79	3.05	3.53/B
9+12+18	1.96	2.62	3.92	-	8.50	2.70	9.92	2.64	0.77	3.17	3.22/A	2.08	2.77	4.15	-	9.00	2.80	10.12	2.55	0.79	3.09	3.53/B
12+12+12	2.83	2.83	2.83	-	8.50	2.70	9.80	2.64	0.77	3.13	3.22/A	3.00	3.00	3.00	-	9.00	2.80	10.00	2.55	0.79	3.05	3.53/B
12+12+18	2.43	2.43	3.64	-	8.50	2.70	10.04	2.64	0.77	3.21	3.22/A	2.57	2.57	3.86	-	9.00	2.80	10.24	2.55	0.79	3.12	3.53/B
7+7+7+7	2.05	2.05	2.05	2.05	8.20	2.60	9.80	2.53	0.74	3.13	3.24/A	2.25	2.25	2.25	2.25	9.00	2.80	10.00	2.49	0.73	3.05	3.61/A
7+7+7+9	1.98	1.98	1.98	2.56	8.50	2.70	9.80	2.64	0.77	3.13	3.22/A	2.10	2.10	2.10	2.70	9.00	2.80	10.00	2.49	0.73	3.05	3.61/A
7+7+7+12	1.80	1.80	1.80	3.10	8.50	2.70	9.80	2.64	0.77	3.13	3.22/A	1.91	1.91	1.91	3.27	9.00	2.80	10.00	2.49	0.73	3.05	3.61/A
7+7+7+18	1.53	1.53	1.53	3.91	8.50	2.70	9.92	2.64	0.77	3.17	3.22/A	1.62	1.62	1.62	4.14	9.00	2.80	10.12	2.49	0.73	3.09	3.61/A
7+7+9+9	1.86	1.86	2.39	2.39	8.50	2.70	9.80	2.64	0.77	3.13	3.22/A	1.97	1.97	2.53	2.53	9.00	2.80	10.00	2.49	0.73	3.05	3.61/A
7+7+9+12	1.70	1.70	2.19	2.91	8.50	2.70	9.80	2.64	0.77	3.13	3.22/A	1.80	1.80	2.31	3.09	9.00	2.80	10.00	2.49	0.73	3.05	3.61/A
7+7+9+18	1.45	1.45	1.87	3.73	8.50	2.70	10.00	2.64	0.77	3.19	3.22/A	1.54	1.54	1.98	3.94	9.00	2.80	10.20	2.49	0.73	3.11	3.61/A
7+7+12+12	1.57	1.57	2.68	2.68	8.50	2.70	9.88	2.64	0.77	3.16	3.22/A	1.66	1.66	2.84	2.84	9.00	2.80	10.08	2.49	0.73	3.07	3.61/A
7+9+9+9	1.75	2.25	2.25	2.25	8.50	2.70	9.80	2.64	0.77	3.13	3.22/A	1.86	2.38	2.38	2.38	9.00	2.80	10.00	2.49	0.73	3.05	3.61/A
7+9+9+12	1.61	2.07	2.07	2.75	8.50	2.70	9.84	2.64	0.77	3.14	3.22/A	1.70	2.19	2.19	2.92	9.00	2.80	10.04	2.49	0.73	3.06	3.61/A
7+9+12+12	1.49	1.91	2.55	2.55	8.50	2.70	9.96	2.64	0.77	3.18	3.22/A	1.58	2.02	2.70	2.70	9.00	2.80	10.16	2.49	0.73	3.10	3.61/A
9+9+9+9	2.13	2.13	2.13	2.13	8.50	2.70	9.80	2.64	0.77	3.13	3.22/A	2.25	2.25	2.25	2.25	9.00	2.80	10.00	2.49	0.73	3.05	3.61/A
9+9+9+12	1.96	1.96	1.96	2.62	8.50	2.70	9.92	2.64	0.77	3.17	3.22/A	2.08	2.08	2.08	2.76	9.00	2.80	10.12	2.49	0.73	3.09	3.61/A

Based on wall mounted combination

COMPATIBLE WITH



HIGH WALL
HND 7/9/12/18/24



HIGH WALL
HKD 9/12/18/24



DUCTED MEDIUM STATIC
PRESSURE DID 12



CASSETTE
CCD 9X/12/18X



CONSOLE
XBD 9X/12/18X



YCZ5-42 RESIDENTIAL MULTISPLIT CINCO

Indoor units combinations	COOLING												HEATING											
	Rated power (kW)					Total cooling power (kW)			Total Input power (kW)			EER/ Energy label	Rated power (kW)					Total heating power (kW)			Total Input power (kW)			COP/ Energy label
	Unit A	Unit B	Unit C	Unit D	Unit E	Rated	Min.	Max.	Rated	Min.	Max.		Unit A	Unit B	Unit C	Unit D	Unit E	Rated	Min.	Max.	Rated	Min.	Max.	
18+18	5.00	5.00	-	-	-	10.00	2.44	12.20	2.94	0.67	3.43	3.40/A	5.50	5.50	-	-	-	11.00	2.69	12.20	3.13	0.81	3.49	3.51/B
18+24	5.00	6.80	-	-	-	11.80	2.88	13.50	3.62	0.79	3.80	3.26/A	5.27	7.03	-	-	-	12.30	3.07	13.50	3.52	0.91	3.86	3.49/B
7+7+24	2.05	2.05	6.80	-	-	10.90	2.66	13.20	3.27	0.73	3.72	3.33/A	2.34	2.34	7.50	-	-	12.18	2.84	13.20	3.44	0.81	3.77	3.54/B
7+9+24	2.05	2.65	6.80	-	-	11.50	2.80	13.50	3.50	0.77	3.80	3.29/A	2.15	2.77	7.38	-	-	12.30	2.99	13.50	3.48	0.85	3.86	3.53/B
7+12+18	2.05	3.54	5.00	-	-	10.59	2.58	13.00	3.15	0.71	3.66	3.36/A	2.34	3.70	5.50	-	-	11.54	3.00	13.20	3.25	0.85	3.77	3.55/B
7+12+24	2.00	3.43	6.87	-	-	12.30	3.00	13.50	3.82	0.82	3.80	3.22/A	2.00	3.43	6.87	-	-	12.30	3.20	13.50	3.48	0.90	3.86	3.53/B
7+18+18	2.05	5.00	5.00	-	-	12.05	2.94	13.50	3.72	0.80	3.80	3.24/A	2.00	5.15	5.15	-	-	12.30	3.13	13.50	3.48	0.88	3.86	3.53/B
9+9+18	2.65	2.65	5.00	-	-	10.30	2.51	12.38	3.05	0.69	3.48	3.38/A	2.80	2.80	5.50	-	-	11.10	2.89	12.38	3.12	0.82	3.54	3.56/B
9+9+24	2.65	2.65	6.80	-	-	12.10	2.95	13.50	3.74	0.81	3.80	3.24/A	2.64	2.64	7.02	-	-	12.30	3.15	13.50	3.48	0.89	3.86	3.53/B
9+12+12	2.65	3.54	3.54	-	-	9.73	2.37	11.80	2.84	0.65	3.32	3.43/A	2.80	3.70	3.70	-	-	10.20	2.65	11.80	2.86	0.76	3.37	3.57/B
9+12+18	2.65	3.54	5.00	-	-	11.19	2.73	13.50	3.38	0.75	3.80	3.31/A	2.80	3.70	5.50	-	-	12.00	3.12	13.60	3.39	0.88	3.89	3.54/B
9+12+24	2.46	3.28	6.56	-	-	12.30	3.00	13.50	3.82	0.82	3.80	3.22/A	2.46	3.28	6.56	-	-	12.30	3.20	13.50	3.48	0.90	3.86	3.53/B
9+18+18	2.46	4.92	4.92	-	-	12.30	3.00	13.50	3.82	0.82	3.80	3.22/A	2.46	4.92	4.92	-	-	12.30	3.20	14.06	3.48	0.90	4.02	3.53/B
12+12+12	3.54	3.54	3.54	-	-	10.62	2.59	13.00	3.17	0.71	3.66	3.35/A	3.70	3.70	3.70	-	-	11.10	2.89	13.00	3.12	0.82	3.71	3.56/B
12+12+18	3.54	3.54	5.00	-	-	12.08	2.95	13.50	3.73	0.81	3.80	3.24/A	3.51	3.51	5.28	-	-	12.30	3.20	14.00	3.48	0.90	4.00	3.53/B
12+12+24	3.08	3.08	6.14	-	-	12.30	3.00	13.50	3.82	0.82	3.80	3.22/A	3.08	3.08	6.14	-	-	12.30	3.20	13.50	3.48	0.90	3.86	3.53/B
12+18+18	3.08	4.61	4.61	-	-	12.30	3.00	13.50	3.82	0.82	3.80	3.22/A	3.08	4.61	4.61	-	-	12.30	3.20	14.11	3.48	0.90	4.03	3.53/B
12+18+24	2.73	4.10	5.47	-	-	12.30	3.00	13.50	3.82	0.82	3.80	3.22/A	2.73	4.10	5.47	-	-	12.30	3.20	13.50	3.48	0.90	3.86	3.53/B
18+18+18	4.10	4.10	4.10	-	-	12.30	3.00	13.50	3.82	0.82	3.80	3.22/A	4.10	4.10	4.10	-	-	12.30	3.20	14.22	3.48	0.90	4.06	3.53/B
7+7+7+18	2.05	2.05	2.05	5.00	-	11.15	2.72	13.50	3.37	0.74	3.80	3.31/A	2.21	2.21	2.21	5.67	-	12.30	3.20	14.00	3.44	0.86	4.00	3.58/B
7+7+7+24	1.91	1.91	1.91	6.57	-	12.30	3.00	13.50	3.82	0.82	3.80	3.22/A	1.91	1.91	1.91	6.57	-	12.30	3.20	13.50	3.44	0.86	3.86	3.58/B
7+7+9+18	2.05	2.05	2.65	5.00	-	11.75	2.87	13.50	3.60	0.78	3.80	3.26/A	2.10	2.10	2.70	5.40	-	12.30	3.20	14.00	3.44	0.86	4.00	3.58/B
7+7+9+24	1.83	1.83	2.36	6.28	-	12.30	3.00	13.50	3.82	0.82	3.80	3.22/A	1.83	1.83	2.36	6.28	-	12.30	3.20	13.50	3.44	0.86	3.86	3.58/B
7+7+12+12	2.05	2.05	3.54	3.54	-	11.18	2.73	13.50	3.38	0.75	3.80	3.31/A	2.34	2.34	3.70	3.70	-	12.08	3.14	14.00	3.37	0.84	4.00	3.58/B
7+7+12+18	1.96	1.96	3.35	5.03	-	12.30	3.00	13.50	3.82	0.82	3.80	3.22/A	1.96	1.96	3.35	5.03	-	12.30	3.20	14.00	3.44	0.86	4.00	3.58/B
7+7+12+24	1.72	1.72	2.95	5.91	-	12.30	3.00	13.61	3.82	0.82	3.83	3.22/A	1.72	1.72	2.95	5.91	-	12.30	3.20	13.61	3.44	0.86	3.89	3.58/B
7+7+18+18	1.72	1.72	4.43	4.43	-	12.30	3.00	13.61	3.82	0.82	3.83	3.22/A	1.72	1.72	4.43	4.43	-	12.30	3.20	13.61	3.44	0.86	3.89	3.58/B
7+7+18+24	1.54	1.54	3.95	5.27	-	12.30	3.00	13.75	3.82	0.82	3.87	3.22/A	1.54	1.54	3.95	5.27	-	12.30	3.20	13.75	3.44	0.86	3.93	3.58/B
7+9+9+12	2.05	2.65	2.65	3.54	-	10.89	2.66	13.50	3.27	0.73	3.80	3.33/A	2.34	2.80	2.80	3.70	-	11.64	3.03	14.00	3.24	0.82	4.00	3.59/B
7+9+9+18	2.00	2.57	2.57	5.16	-	12.30	3.00	13.50	3.82	0.82	3.80	3.22/A	2.00	2.57	2.57	5.16	-	12.30	3.20	14.00	3.44	0.86	4.00	3.58/B
7+9+9+24	1.76	2.26	2.26	6.02	-	12.30	3.00	13.59	3.82	0.82	3.83	3.22/A	1.76	2.26	2.26	6.02	-	12.30	3.20	13.59	3.44	0.86	3.88	3.58/B
7+9+12+12	2.05	2.65	3.54	3.54	-	11.78	2.87	13.50	3.61	0.78	3.80	3.26/A	2.15	2.77	3.69	3.69	-	12.30	3.20	14.00	3.44	0.86	4.00	3.58/B
7+9+12+18	1.87	2.41	3.21	4.81	-	12.30	3.00	13.52	3.82	0.82	3.81	3.22/A	1.87	2.41	3.21	4.81	-	12.30	3.20	14.07	3.44	0.86	4.02	3.58/B
7+9+12+24	1.66	2.13	2.84	5.67	-	12.30	3.00	13.66	3.82	0.82	3.85	3.22/A	1.66	2.13	2.84	5.67	-	12.30	3.20	13.66	3.44	0.86	3.90	3.58/B
7+9+18+18	1.66	2.13	4.26	4.26	-	12.30	3.00	13.66	3.82	0.82	3.85	3.22/A	1.66	2.12	4.26	4.26	-	12.30	3.20	13.66	3.44	0.86	3.90	3.58/B
7+9+18+24	1.48	1.91	3.82	5.09	-	12.30	3.00	13.79	3.82	0.82	3.88	3.22/A	1.48	1.91	3.82	5.09	-	12.30	3.20	13.79	3.44	0.86	3.94	3.58/B
7+12+12+12	2.01	3.43	3.43	3.43	-	12.30	3.00	13.50	3.82	0.82	3.80	3.22/A	2.01	3.43	3.43	3.43	-	12.30	3.20	14.02	3.44	0.86	4.01	3.58/B

Monobloc & Floor Standing Ranges

[MODEL NAME]

Page

ON/OFF PORTABLE

MAF



86

WINDOW



WFD



87

ON/OFF FLOOR STANDING

SBF



88

9
2.5 kW

12
3.5 kW

48
12.5 kW



Fixed Speed
Cooling only

MAF

ON/OFF PORTABLE



+ PRODUCTS

- Wireless remote control provided.
- Economic.
- Installation kit for window and wall.
- Self-evaporative system.
- No fluid handling.



RC08C

FEATURES



R410A FLUID



ANTIBACTERIA FILTER



AUTO CLEAN/DRY



I FEEL



SLEEP MODE



TURBO MODE



SELF DIAGNOSTIC



LOW BATTERY INDICATION



AUTO RESTART (MEMORY)



REMOTE CONTROL LOCK



ADVANCED DEFROST



- 0.5 W in standby mode.
- Manual control integrated.



MAF TECHNICAL DATA

Indoor units		AWPO-MAF009-C11	AWPO-MAF012-C11
COOLING			
Rated power	kW	2.64	3.52
Rated power input	kW	1.01	1.35
EER/Energy label		2.61/A	2.61/A
Operating limits	°C	17°/35° Dry bulb	
INDOOR UNIT			
Type		Monobloc	Monobloc
Sound pressure level to 1 m (LS/MS/HS)	dB(A)	46/49/52	46/49/52
Sound power Level	dB(A)	65	65
Airflow	m³/h	370	370
Diameter flexible emission duct	mm	150	
Length range of heat emission duct	m	0.50 - 1.5	
Dehumidification	l/h	1.6	1.8
Outline dimensions (WxHxD)	mm	467x765x397	467x765x397
Package dimensions (WxHxD)	mm	517x880x437	517x880x437
Net weight/Gross weight	kg	30/34	33.5/37
Part number		7MB021056	7MB021057



- ECO DC Inverter Window.
- New refrigerant R32 environmental friendly.
- Unique design that can reach the ECO design requirements and 1W in standby.
- High efficiency that can reach SEER over 5.0.
- Bi-operation methods, on unit or by remote control.



+ PRODUCTS

- Monobloc.
- Unique solution.
- DC inverter.
- R32 fluid.
- No fluid handling.



WFD RC

FEATURES



R32 FLUID



1 W STANDBY POWER



LOW VOLTAGE STARTUP



MOTORIZED 4D AIRFLOW



SLEEP MODE



SELF DIAGNOSTIC



AUTO RESTART (MEMORY)

Monobloc & Floor-standing

WFD TECHNICAL DATA

Indoor units		AWWR-WFD009-C11	AWWR-WFD012-C11
COOLING			
Rated power	kW	2.75	3.7
Pdesignnc	kW	2.75	3.7
Rated power input	kW	0.81	1.09
SEER/Energy label		5.10/A	5.10/A
Operating limits	°C	18°/43° Dry bulb	
INDOOR UNIT			
Sound pressure level to 1 m (LS/MS/HS)	dB(A)	45/47/49	45/47/49
Airflow (LS/MS/HS)	m³/h	310/350/380	400/450/490
Dehumidification	l/h	1.0	1.2
Compressor type		Rotary	Rotary
Outline dimensions (WxHxD)	mm	560x375x710	660x428x700
Package dimensions (WxHxD)	mm	623x425x806	739x515x793
Net weight/Gross weight	kg	34/36.7	46/50
Part number		7WT010008	7WT010009
POWER SUPPLY 1~230V - 50 HZ			
Power supply side		Indoor	Indoor
Power cable section	mm²	3x1.0	3x1.5
Fuse rating am	A	10	10

Fixed Speed
Cooling & heating

SBF

ON/OFF FLOOR STANDING



+ PRODUCTS

- Modern design & digital display.
- Auxiliary electrical heater 3.5 kW.



RC08C

FEATURES



R410A FLUID



ANTIBACTERIA FILTER



I FEEL



SLEEP MODE



DIGITAL DISPLAY



PROGRAMMABLE TIMER



SELF DIAGNOSTIC



LOW BATTERY INDICATION



AUTO RESTART (MEMORY)



REMOTE CONTROL LOCK



AUXILIARY HEATER



LOW AMBIENT COOLING





WIFI

- "I Feel" function with precise room temperature control.
- Low ambient cooling operation down to -7°C as a standard.

SBF TECHNICAL DATA

Indoor unit		AWSI-SBF048-N11
Outdoor unit		AWAU-YSF048-H13
COOLING		
Rated power	kW	12.4
Rated power of auxiliary heater	kW	3.50
Rated power input	kW	4.62
EER/Energy label		2.68/D
Operating limits	°C	-7°/43° Dry bulb
HEATING		
Rated power	kW	13.6 (+3.5)
Rated power input	kW	4.84 (+3.5)
COP/Energy label		2.81/D
Operating limits	°C	-7°/24° Dry bulb
INDOOR UNIT		
Sound pressure level to 1 m (LS/HS)	dB(A)	48/56
Sound power level	dB(A)	66
Airflow (LS/HS)	m³/h	1500/1850
Dehumidification	l/h	4.6
Outline dimensions (WxHxD)	mm	550x1800x350
Package dimensions (WxHxD)	mm	685x1910x540
Net weight/Gross weight	kg	48/63.3
Part number		7SP011084
OUTDOOR UNIT		
Sound pressure level to 1 m	dB(A)	61
Sound power level	dB(A)	71
Airflow	m³/h	5600
Compressor type		Scroll
Outline dimensions (WxHxD)	mm	938x1369x392
Package dimensions (WxHxD)	mm	1095x1505x495
Net weight/Gross weight	kg	111/123.4
Part number		7SP062850
POWER SUPPLY 3~400V - 50 HZ - N		
Power supply side		Outdoor
Power cable section	mm²	5x2.5
Fuse rating am	A	25
Electrical connections	mm²	6x1.5
PIPE LINE		
Suction pipe diameter	inches	3/4"
Liquid pipe diameter	inches	1/2"
Max. length	m	20
Max. height	m	10

COMBINATIONS

Indoor unit	Compatible with outdoor unit
Floor standing	Monosplit
<p>SBF</p> 	<p>YSF</p> 

[MODEL NAME]

Page

ON/OFF WATER
CONSOLE

CAO



92 & 94

ON/OFF WATER
SOURCE

**GCAO +
HHF/CAF/DAF**



92 & 96

7
2 kW

9
2.5 kW

12
3.5 kW

18
5 kW

24
7 kW



Unique
solutions

CAO/GCAO: water condensing solution

Easy and simple installation

MONOBLOC SOLUTION



SPLIT SOLUTION

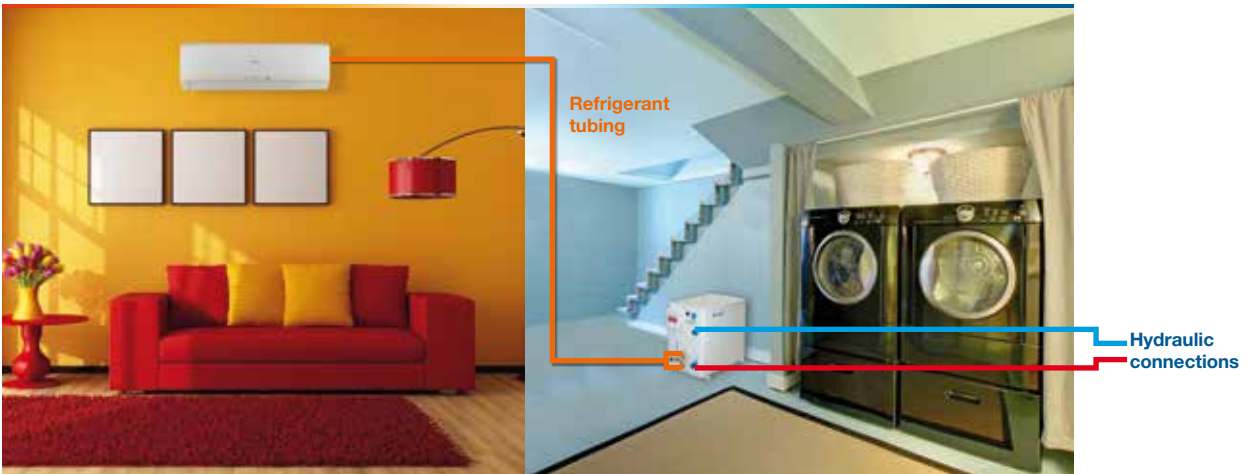

Features

- Ideal solution for building with local or aesthetic restrictions.
- Easy and simple installation.
- Solution for rooms without access to external wall.
- High efficiency system with advanced heat exchanger.
- Built in system protection in water side.

Water monobloc
Cooling only

CAO

ON/OFF WATER CONSOLE



Monobloc solution

Unique solutions



- Electrical heater in option.
- Ideal indoor solution when the building structure or aesthetic reasons forbid a condensing outdoor unit.
- Pressure valve supplied.

+ PRODUCTS

- No outdoor unit.
- No fluid handling.
- Can be connected to public water network.
- French product.

FEATURES



CAO TECHNICAL DATA

Indoor units		CAO 230	CAO 370	CAO 580
COOLING				
Rated power	kW	2.3	3	4.7
Rated power input	kW	0.66	0.85	1.3
EER/Energy label		3.4/E	3.5/D	3.6/D
Operating limits	°C	15°/32° Dry Bulb		
Condenser inlet water temperature		10°/30°		
INDOOR UNIT				
Sound pressure level to 1 m (LS/HS)	dB(A)	37/40	38/41	41/43
Fresh air intake	m³/h	60	60	80
Airflow (LS/HS)	m³/h	450/550	450/550	725/880
Water flow at +15°C	l/h	130	170	270
Compressor type		Rotary	Rotary	Rotary
Dimensions (WxHxD)	mm	1030x620x226	1030x620x226	1390x620x226
Weight	kg	48	49	69
Part number		7CW011016	7CW011017	7CW011018
POWER SUPPLY 1~230V - 50HZ				
Power supply side		Indoor	Indoor	Indoor
Power cable section	mm²	3x1.5	3x1.5	3x1.5
Fuse rating am		6	6	8

OPTIONS

Accessory	Part number	Function
Electrical heater 2/3 kW	7ACEL0006	Simple electrical additional heater 2/3 kW - CAO 230 and 370.
Electrical heater 4,7 kW	7ACEL0007	Simple electrical additional heater 4,7 kW - CAO 580
Simple wired remote control	7ACEL0039	Simple function as ON/OFF, operating mode temperature.

A series of horizontal dotted lines for writing, spanning the width of the page.



Water split
Cooling only

GCAO

ON/OFF WATER SOURCE



Unique solutions



+ PRODUCTS

- No outdoor unit.
- Can be connected to public water network.
- Compact design.



RC08A
(Included with indoor unit)



RCW3
(Included with CAF and DAF only)

FEATURES



R410A FLUID



AUTO CLEAN/DRY



I FEEL



SLEEP MODE



TURBO MODE



LOW BATTERY INDICATION



AUTO RESTART (MEMORY)



REMOTE CONTROL LOCK



No outdoor unit

COMPATIBLE WITH

HIGH WALL HHF



CASSETTE CAF



+ adaptor

DUCTED MEDIUM STATIC PRESSURE DAF



+ adaptor

- Water flow protection by pressure valve.
- High pressure switch with manual reset.
- Super quiet.
- Connection to HHF high wall, CAF cassette and DAF ducted units.
- Ideal solution for premises where it is impossible to install an outdoor unit.
- Connection to recycled or lost water systems.

OPTIONS

Accessory	Part number	Photo	Function
Additional adaptor refer to all CAF/DAF	7ACEL1653		Electronic adaptor between IDU CAF/DAF and ODU GCAO.

GCAO TECHNICAL DATA

Outdoor units		GCAO 9N	GCAO 12N	GCAO 18N	GCAO 24N
COOLING					
Rated power	kW	2.70	3.65	5.85	6.37
Rated power input	kW	0.68	0.94	1.34	1.90
EER/Energy label		4.19/A	3.88/B	4.37/A	3.76/B
Operating limits indoor temperature	°C	17°/32° Dry Bulb			
Condenser inlet water temperature	°C	10°/45°			
WATER SOURCE					
Sound power level to 1 m	dB(A)	49	49	51	53
Waste water flow at + 15°C	l/h	120	160	250	320
Recycled water flow 30/35°C	l/h	600	850	1 250	1 550
Compressor type		Rotary	Rotary	Rotary	Rotary
Hydraulic connection pipe	inches	3/4"	3/4"	3/4"	3/4"
Dimensions (WxHxD)	mm	625x473x360	625x473x360	625x473x360	625x473x360
Weight	kg	41	45	50	56
Part number		7SP101040	7SP101041	7SP101045	7SP101044
PIPE LINE					
Suction pipe diameter	inches	3/8"	1/2" *	1/2"	1/2"
Liquid pipe diameter	inches	1/4"	1/4"	1/4"	1/4"
Max. length	m	25	25	25	25
Max. height	m	15	15	15	15
INDOOR UNIT					
Power supply		1~230V - 50 Hz			
Power supply side		Indoor	Indoor	Indoor	Indoor
Power cable section	mm²	3x1.5	3x1.5	3x1.5	3x2.5
Fuse rating am	A	10	10	10	16
Electrical connections	mm²	3x1.5	3x1.5	3x1.5	4x2.5

Indoor units high wall		AWSI-HHF009-N11	AWSI-HHF012-N11	AWSI-HHF018-N11	AWSI-HHF024-N11
Sound pressure level to 1 m (LS/MS/HS/SS)	dB(A)	32/35/37/40	32/35/38/41	35/39/42/45	38/41/44/47
Sound power level (LS/MS/HS/SS)	dB(A)	42/45/47/50	42/45/48/51	45/49/52/55	48/51/54/57
Airflow (LS/MS/HS/SS)	m³/h	310/340/370/400	350/420/500/550	550/650/780/850	550/650/780/850
Dimensions (WxHxD)	mm	730x255x174	790x265x177	940x298x200	940x298x200
Weight	kg	8	9	13	13
Part number		7SP022856	7SP022857	7SP022858	7SP022859

Indoor units cassettes		AWSI-CAF012-N11**	AWSI-CAF012-N11	AWSI-CAF018-N11	AWSI-CAF024-N11
Sound pressure level to 1 m (LS/MS/HS)	dB(A)	43/45/47	43/45/47	43/45/47	43/45/47
Sound power level (LS/MS/HS)	dB(A)	53/55/57	53/55/57	53/55/57	53/55/57
Airflow (LS/MS/HS)	m³/h	620/720/820	620/720/820	620/720/820	1000/1080/1180
Dimensions (WxHxD)	mm	600x230x600	600x230x600	600x230x600	840x260x840
Frame dimensions (WxHxD)	mm	650x650x50	650x650x50	650x650x50	950x950x60
Weight	kg	20	20	20	36
Part number		7SP042208	7SP042208	7SP042209	7SP042210
Part number frame		7ACVF0547	7ACVF0547	7ACVF0547	7ACVF0548
Electronic adaptor between IDU CAF to ODU GCAO	Part nb.	7ACEL1653			

Indoor units ducted		AWSI-DAF009-N11	AWSI-DAF012-N11	AWSI-DAF018-N11	AWSI-DAF024-N11
Sound pressure level to 1 m (LS/MS/HS)	dB(A)	34/36/37	36/38/40	38/40/42	40/42/44
Sound power level (LS/MS/HS)	dB(A)	44/46/47	46/48/50	48/50/52	50/52/54
Airflow (LS/MS/HS)	m³/h	400/470/550	490/540/600	680/750/840	1220/1350/1400
External static pressure	Pa	25 (0-25)	25 (0-25)	25 (0-25)	25 (0-100)
Dimensions (WxHxD)	mm	913x680x220	913x680x220	1012x736x266	1270x504x268
Weight	kg	27	27	36	37
Part number		7SP032114	7SP032115	7SP032116	7SP032117
Electronic adaptor between IDU DAF to ODU GCAO	Part nb.	7ACEL1653			

* To connect HHF 12, a flare adapter: 1/2" Female x 3/8" Male is mandatory.

** CAF 12 matching with GCAO 9.

[MODEL NAME]

Page

VERTICAL CABINET

VERTICAL AIR CABINET

X AC



100

VERTICAL WATER CABINET

X WC



102

ROOFTOP

ROOFTOP UNIT

HAN



104

8 kW 12.5 kW 14 kW 17 kW 19 kW 25 kW 30 kW 40 kW 45 kW 55 kW

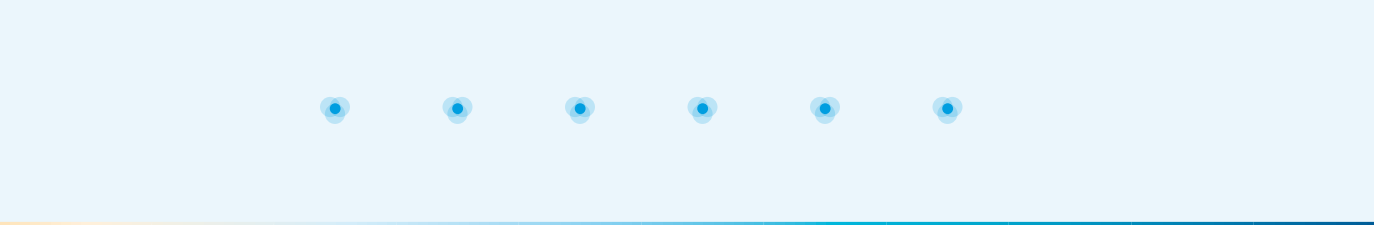
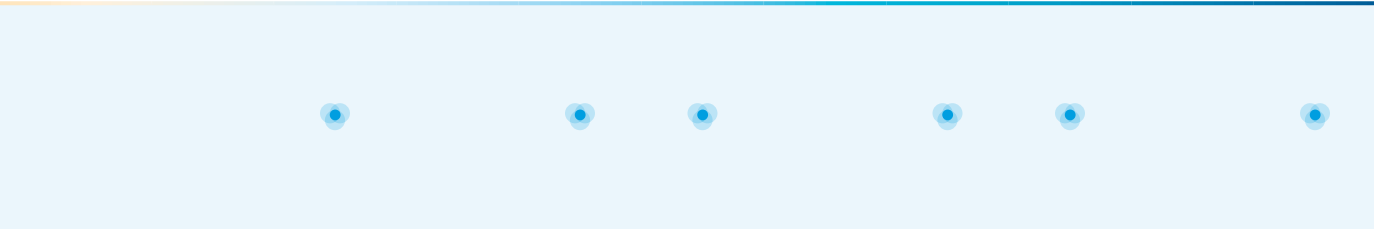



+ PRODUCTS

- Easy installation and maintenance.
- “Plug & Play” for replacement.
- Air discharge through duct network or plenum.
- Adjustable available static pressure.

FEATURES



MAIN OPTIONS

- Room thermostat.
- Hot water heating coil.
- “All season” system (cooling mode operation down to outdoor temperature of -10°C).
- Remote fault reporting.
- Plenum, fresh air.
- Pipe link (10 m).

MANDATORY ACCESSORIES

- Set of female valves.



- Split system with outdoor condenser fan unit.
- Temperature control by thermostat on the front frame or by a remote control (optional).
- Electrical, refrigeration and thermal protection devices.
- Available with or without neutral in 3P/400V/50Hz.
- “High ventilation” in standard for XAC 1200 and 1900.
- “Plug & Play” to replace old Airwell vertical cabinet.
- High ventilation kit and electrical heater factory mounted or in accessory on demand.

OPERATING LIMIT FOR STANDARD UNIT

Indoor unit	
Minimum air temperature (room/intake/around unit)	21°C DB/15°C WB
Maximum air temperature (room/intake/around unit)	32°C DB/23°C WB
Outdoor unit	
Minimum air temperature/with all-season kit	15°C DB/-10°C
Maximum air temperature	50°C DB

X AC TECHNICAL DATA

Indoor units		X AC 1200	X AC 1900	X AC 2450	X AC 3250	X AC 4650	X AC 6450
Outdoor units		CONA 34	CONA 54	CONA 74	CONA 104	CONA 74	CONA 104

PRODUCT CODES

Indoor units with neutral	Standard	Code	7XU122245	7XU122267	7XU122078	7XU122079	7XU122080	7XU122081
	With electrical heater	Code	7XU122248	7XU122249	7XU122250	7XU122251	7XU122252	7XU122253
	With high ventilation	Code	7XU122245	7XU122267	7XU122256	7XU122257	7XU122258	7XU122259
Outdoor units with neutral	Standard	Code	7XU131025	7XU131026	7XU131027	7XU131028	2 x 7XU131027	2 x 7XU131028
	With all season control	Code	7XU131083	7XU131059	7XU131058	7XU131060	2 x 7XU131058	2 x 7XU131060
Indoor units	Without neutral	Code	7XU122266	On demand	7XU122221S	7XU122222S	7XU122224S	7XU122227S
Outdoor units	Without neutral, with all season control	Code	7XU131084	7XU131068S	7XU131064S	7XU131063S	2 x 7XU131064S	2 x 7XU131063S

RATED POWERS

Cooling	Power	kW	12.3	16.2	19.8	29.0	38.9	55.0
	Nominal power input Cooling + Ventilation (SV/HV)	kW	4.2/4.4	5.7/6.2	7.1/7.5	10.2/11.3	15/16	22.2/23.7
	Nominal power input Electrical Heating + Ventilation (SV/HV)	kW	7.6/8	9.2/10.4	13.6/14	16.8/17.6	28.8/6	35.2/36.4
	EER		2.93	2.84	2.78	2.84	2.6	2.5
	Cooling circuit	nb	1	1	1	1	2	2

INDOOR UNIT

Power supply			400V/3P/50Hz + neutral depending on models					
Ventilation	Available static pressure	Pa	200	300	200	200	250	290
	Available static pressure (HV)	Pa	200	380	400	400	480	480
	Nominal airflow	m³/h	2000	3200	4500	5800	9000	12000
	Airflow range (min/max)	m³/h	1500/2500	2500/3800	3600/5400	4600/7000	7200/10800	9500/14500
Sound levels	Sound power level	dB(A)	56	68	75	81	77	85
Dimensions	WxHxD	mm	890x1540x430	1000x1735x500	1300x1840x600	1530x1840x600	1715x1970x790	1980x1970x790
	Plenum height	mm	220	260	350	350	400	400
Weight	Indoor unit	kg	136	182	265	350	525	600

OUTDOOR UNIT

Power supply			400V/3P/N/50Hz					
Condenser unit			1	1	1	1	2	2
Ventilation	Max. airflow	m³/h	8600	7600	8550	14000	8550	14000
	Speed	tr/mn	870					
Sound levels	Sound power level	dB(A)	52	58	61	73	64	76
Dimensions	WxHxD	mm	885x840x825	885x840x825	1141x840x885	1546x840x885	1141x840x885	1546x840x885
Weight	Outdoor unit	kg	59	68	93	130	93	130
Pipe line	Suction pipe diameter	inches	1/2"	1/2"	5/8"	3/4"	5/8"	3/4"
	Liquid pipe diameter	inches	3/8"	3/8"	1/2"	5/8"	1/2"	5/8"
	Max. length	m	45	45	45	45	45	45

ACCESSORIES

Set of female valves	Code	7ACFH0054	7ACFH0055	7ACFH0056	7ACFH0061	7ACFH0057	7ACFH0060
Pipe link - Length 10m	Code	7ACFH0210	7ACFH0211	7ACFH0212	7ACFH0213	7ACFH0214	7ACFH0215
Hot water coil	kW	15.5	29.7	38.5	50	77	94
	Code	7ACFH0062	7ACFH0063	7ACFH0064	7ACFH0118	7ACFH0180	7ACFH0170
ON/OFF switch and room thermostat	Code	7ACEL0041	7ACEL0041	7ACEL0032	7ACEL0032	7ACEL0032	7ACEL0032
Remote fault reporting	Code	On demand	On demand	7ACEL0072	7ACEL0072	7ACEL0071	7ACEL0071
Air distribution duct frame	Code	7ACVF0582	7ACVF0102	7ACVF0050	7ACVF0051	7ACVF0052	7ACVF0052
Total rear air intake duct frame	Code	7ACVF0041	7ACVF0104	7ACVF0043	7ACVF0044	7ACVF0045	7ACVF0046
Front air distribution plenum	Code	7ACVF0105	7ACVF0106	7ACVF0108	7ACVF0109	7ACVF0110	7ACVF0111
Fresh air supplied	Code	7ACVF0047	7ACVF0047	On demand	On demand	On demand	On demand

Light CAC
Cooling only

X WC VERTICAL WATER CABINET



+ PRODUCTS

- Easy installation and maintenance.
- Public or recycled water operation.
- Air discharge through duct network or plenum.
- Adjustable available static pressure.

FEATURES



MAIN OPTIONS

- Room thermostat.
- Electrical heater.
- Hot water heating coil.
- Remote fault reporting.
- Plenum.
- Duct flange.



- Monobloc system.
- Temperature control by thermostat on the front frame or by a remote control (optional).
- Electrical, refrigeration and thermal protection devices.
- “High ventilation” in standard for CX25, XWC 1200 and 1900.
- “Plug & Play” to replace old Airwell vertical cabinet.

OPERATING LIMIT FOR STANDARD UNIT

Cooling Mode	
Minimum air temperature	21°C DB/15°C WB
Maximum air temperature	32°C DB/23°C WB
Minimum water temperature	+10°C
Maximum water temperature	+30°C

X WC TECHNICAL DATA

Indoor units			CX 25	X WC 1200	X WC 1900	X WC 2450	X WC 3250	X WC 4650	
PRODUCT CODES									
400V/3P/50 Hz	With valve	Code	7XU012192	7XU012190	7XU012187	7XU012029	7XU012030	7XU012031	
RATED POWERS									
Cooling	Power	kW	8	15.0	18.0	23.0	32.4	45.7	
	Nominal power input Cooling + Ventilation (SV/HV)	Wasted water	kW	2.1/2.6	3.8/4	5.1/5.6	6.4/6.8	9.2/10.3	13.5/14.5
		Recycled water	kW	-	3.6/3.8	4.6/5.1	5.8/6.2	8.3/9.4	12.4/13.4
	Nominal power input Electrical Heating + Ventilation (SV/HV)	kW	3.8/4.6	9.4/9.6	9.2/10.4	13.6/14	16.8/17.6	28.8/30	
	EER		3.80	3.94	3.52	3.59	3.52	3.38	
Cooling circuit		1	1	1	1	1	2		
VENTILATION									
Available static pressure		Pa	100	200	250	230	250	250	
Available static pressure (HV)		Pa	320	380	400	400	480	480	
Nominal airflow		m ³ /h	1500	2000	3200	4500	5800	9000	
Airflow range (min/max)		m ³ /h	1200/1850	1500/2500	2500/3800	3600/5400	4600/7000	7200/10800	
HYDRAULIC CIRCUIT									
Wasted water	Water flow	m ³ /h	0.34	0.91	0.95	1	1.7	2.8	
	Pressure drop	kPa	6	37	30	22	35	18	
Recycled water	Water flow	m ³ /h	1.47	3.16	3.05	4.3	5.8	8.3	
	Pressure drop	kPa	35	80	65	60	40	56	
SOUND LEVELS									
Sound power level*		dB(A)	51	51	55	58	64	60	
POWER SUPPLY									
Power supply			400V/3P/50 Hz						
DIMENSIONS									
Indoor unit (WxHxD)		mm	800x1280x407	890x1540x404	1000x1735x474	1300x1840x600	1530x1840x600	1715x1970x790	
Plenum height		mm	300	220	260	350	350	400	
WEIGHT									
Indoor unit		kg	125	151	199	305	380	565	
ACCESSORIES									
Electric heater (400V/3P/50 Hz)	kW		5.4	9	12	18	22.5	37.5	
	Code		7ACEL0018	7ACEL0042	7ACEL0043	7ACEL0057	7ACEL0058	7ACEL0116	
Hot water coil	kW		-	15.5	29.7	38.5	50	77	
	Code		-	7ACFH0062	7ACFH0063	7ACFH0064	7ACFH0118	7ACFH0180	
ON/OFF switch and room thermostat	Code		7ACEL0030	7ACEL0041	7ACEL0041	7ACEL0032	7ACEL0032	7ACEL0032	
Sum heating resistance	Code		7ACEL0027	7ACEL0029	included	-	-	-	
Remote fault reporting	Code		-	-	-	7ACEL0072	7ACEL0072	7ACEL0071	
Air distribution duct frame	Code		-	7ACVF0101	7ACVF0102	7ACVF0050	7ACVF0051	7ACVF0052	
Total rear air intake duct frame	Code		-	7ACVF0041	7ACVF0104	-	-	-	
Front air distribution plenum	Code		7ACVF0112	7ACVF0105	7ACVF0106	7ACVF0108	7ACVF0109	7ACVF0110	
Fresh air supplied	Code		-	7ACVF0047	7ACVF0047	-	-	-	

* Total sound pressure dB(A) (4m) under nominal conditions in a room of 1000m³ (reverberation 0.83s).



+ PRODUCTS

- Weather resistant casing with external panels and drain pan coated with powder-based epoxy paint color RAL 7040.
- Base rail with forklift slots to facilitate transportation and handling.



RCW2
(optional)

FEATURES



R410A FLUID

MAIN OPTIONS

- Electric heater.

MANDATORY ACCESSORIES

- Synthetic air filter.
- Programmable controller RCW2 to Controls up to 15 units with independent set points and programming.



- Technical compartment independent from airstreams allowing maintenance tasks to be performed without disturbing the unit operation.
- High efficiency Scroll compressor with crankcase heater.
- Condenser coils with hydrophilic coated fins to improve removal of water droplets during defrost cycles.
- Standard microprocessor-based control by CAC controller.
- All seasons kit integrated.

OPERATING LIMIT

Cooling mode

Minimum indoor air temperature	21°C DB/15°C WB
Maximum indoor air temperature	32°C DB/23°C WB
Minimum outdoor air temperature with all-season kit	-10°C DB
Maximum outdoor air temperature	50°C DB

Heating mode

Maximum indoor air temperature	27°C DB
Minimum outdoor air temperature	-10°C
Maximum outdoor air temperature	24°C (16°C for HAN 25)

HAN TECHNICAL DATA

Outdoor units			HAN 13	HAN 15	HAN 17	HAN 19	HAN 25	HAN 31
PRODUCT CODES								
With all season control	Code		7HL023009	7HL023010	7HL023011	7HL023012	7HL023013	7HL023014
RATED POWERS								
Cooling	Power	kW	13.0	14.5	16.8	18.9	25.4	31.0
	Rated power input	kW	4.5	4.9	6.0	6.5	8.3	10.0
	EER		2.88	2.95	2.8	2.9	2.95	3.1
Heating	Power	kW	12.1	14.2	15.8	19.0	24.2	30.5
	Rated power input	kW	4.3	4.5	5.7	6.0	8.8	9.5
	COP		2.8	3.1	2.7	3.1	2.75	3.2
VENTILATION								
Available static pressure	Pa		100	170	160	210	240	250
Airflow	Indoor fan	m ³ /h	2640	2940	3190	3860	4780	5530
	Outdoor fan	m ³ /h	9000	9000	9000	9000	12000	12000
SOUND LEVELS								
Sound power	Indoor	dB(A)	79.3	79.3	79.3	83.1	84.9	86.4
	Outdoor	dB(A)	75.0	75.0	75.0	72.7	78.2	82.7
POWER SUPPLY								
Power supply			400V/3P/N/50 Hz					
DIMENSIONS								
Outdoor unit (WxHxD)	mm		1320x1345x905	1320x1345x905	1320x1345x905	1320x1345x905	1420x1445x1320	1420x1445x1320
WEIGHT								
Outdoor unit	kg		219	223	223	243	320	343
MANDATORY ACCESSORIES								
Air filter	Code		7ACVF0481	7ACVF0481	7ACVF0481	7ACVF0481	7ACVF0482	7ACVF0482
Remote control RCW2	Code		7ACEL1212	7ACEL1212	7ACEL1212	7ACEL1212	7ACEL1212	7ACEL1212
OPTION								
Electric heater	kW		9	9	12	12	12	12
	Code		7ACEL1217	7ACEL1217	7ACEL1219	7ACEL1219	7ACEL1219	7ACEL1219

Others options are available on demand.

VRF Range Outdoor units

[MODEL NAME]		Capacity (HP)	Cooling power (kW)	Heating power (kW)	Page	
MINI FLOWLOGIC II	YCV150		5	15	17	112
	YCV180		6	18	20	112
	YCVFD280		10	28	31.5	112
FLOWLOGIC III	YDV280		10	28	31.5	114
	YDV400		14	40	45	114
	YDV450		16	45	50	114
	YDV504		18	50.4	56.5	114
	YDV560		20	56	63	114
	YDV680		24	68	73	114

Capacity (HP)	Cooling power (kW)	Heating power (kW)	[OUTDOOR UNITS]	[INDOOR UNITS]	
				Maximum indoor units connectable	Range cooling power connectable* (kW)
5	15.0	17.0	1 X YCV150	8	7.5 - 19.5
6	18.0	20.0	1 X YCV180	9	9 - 23
10	28.0	31.5	1 X YCVFD280 or 1 X YDV280	16 or 20	14 - 36
14	40.0	45.0	1 X YDV400	29	20 - 52
16	45.0	50.0	1 X YDV450	33	22.5 - 58.5
18	50.4	56.5	1 X YDV504	37	25.2 - 65.5
20	56.0	63.0	1 X YDV560	41	28 - 72
24	68.0	76.5	1 X YDV680	49	34 - 88
28	80.0	87.5	2 X YDV400	58	40 - 104
30	85.0	95.0	1 X YDV400 + 1 X YDV450	62	43 - 110.5
32	90.0	100.0	2 X YDV450	64	45 - 117
34	96.0	108.0	1 X YDV450 + 1 X YDV560	64	48 - 124.5
36	101.0	113.0	1 X YDV450 + 1 X YDV560	64	51 - 131
38	108.0	119.0	1 X YDV504 + 1 X YDV560	64	54 - 140
40	113.0	126.5	2 X YDV560	64	57 - 146.5
44	123.5	137.5	1 X YDV560 + 1 X YDV680	64	62 - 160.5
48	135.0	150.0	2 X YDV680	64	68 - 175.5
50	140.8	158	1 X YDV400 + 2 X YDV504	64	70.4 - 183.04
52	146	163	2 X YDV450 + 1 X YDV560	64	73 - 189.8
54	151.4	169.5	1 X YDV450 + 1 X YDV504 + 1 X YDV560	64	75.7 - 196.82
56	157	176	2 X YDV450 + 1 X YDV560	64	78.5 - 204.1
58	162.4	182.5	1 X YDV504 + 2 X YDV560	64	81.2 - 211.12
60	168	189	3 X YDV560	64	84 - 218.4
64	180	199	2 X YDV560 + 1 X YDV680	64	90 - 234
68	192	209	1 X YDV560 + 2 X YDV680	64	96 - 249.6
72	204	219	3 X YDV680	64	102 - 265.2

MORE OPTIONAL OUTDOOR CAPACITY

The basic outdoor unit can be combined being modular in standard. The combined outdoors will get the capacity at the interval of 72 HP. Airwell VRF system has the advantage to be able to operate with only one indoor unit (minimum capacity connected must be 50%).

* Indoor total capacity can be 50% - 130% of outdoor capacity.

CAPACITY (kBtu/h)

Capacity (HP)**Cooling (kW)****Heating (kW)**

[MODEL NAME]

Page

HIGH WALL

NEW

HBV



124

CASSETTE 600X600

CBV



125

CASSETTE 900X900

CCV



126

FLOOR CEILING

FAV



127

DUCTED LOW STATIC PRESSURE

UPGRADE

DAV



128

DUCTED MEDIUM STATIC PRESSURE

DBV



129

DUCTED HIGH STATIC PRESSURE

DCV



130

CONSOLE

EAV



131

AHU CONNECTION KIT



132

VRF Range
Indoor units

7	9	12	16	18	24	28	30	38	48	72	96	192
0.75	1.25	1.5	1.75	2.25	3	3.5	3.75	4.75	6	9	12	24
2.2	2.8	3.6	4.5	5.6	7.1	8	9	11.2	14	22.6	28	56
2.5	3.2	4	5	6.3	8	9	10	12.5	16	25	31.5	63

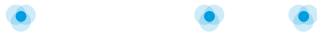

Why choosing a VRF system?



■ One system for multiple applications



Shopping centers



Villas



Hostels



Offices

■ Extrem versatility

- All seasons
- Instantaneous mode change (heat/cool)
- Extendable system
- Any indoor unit



HIGH WALL **HBV**



CASSETTE 600x600 **CBV**



CASSETTE 900x900 **CCV**



FLOOR CEILING **FAV**



DUCTED LOW STATIC PRESSURE **DAV**



DUCTED MEDIUM STATIC PRESSURE **DBV**



DUCTED HIGH STATIC PRESSURE **DCV**



CONSOLE **EAV**



AHU CONNECTION KIT

■ Easy installation

- Professional selection software
- Easy setup (plumbing, electricity, regulation...)
- Ideal solution for refurbishment (easy installation also in inhabited places)

Why choosing an Airwell VRF?

- Wide range of power: from 5 to 72 HP (from 15 to 240 kW)
- Silent system
- Compact solution: small footprint
- High performance: COP until 4.5
- Certified Eurovent



(certification in progress)

Performant system

USE HIGH EFFICIENCY DC INVERTER SCROLL COMPRESSOR, HIGH EFFICACITY, LOW NOISE

The highly efficient Scroll compressor is equipped with a “Framen Compliance Mechanism” that allows movement in the axial direction of the frame supporting the cradle Scroll. This greatly reduces both leakage and friction loss, ensuring very high efficiency throughout the speed range.

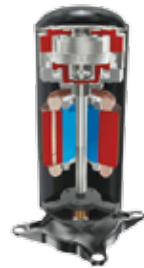

HIGH EFFICIENCY DC FAN MOTOR

The speed of wide range DC fan motor can be adjusted from 0 to 1000 tr/min.

Compared to conventional AC motors, a DC fan motor offers greater operating efficiency, especially during low speed rotation. The efficiency could be 90%.



HEAT EXCHANGER ADOPTS THE SUBCOOLING TECHNOLOGY: HIGH EFFICIENCY

- The system is cooled with little refrigerant.
- Improve subcooling degree of refrigerant.
- Avoid energy loss due to refrigerant flash evaporating when it goes through PMV.
- W-model Ø8 innergrooved tube.
- Hydrophilic aluminium coil fin, it will increase efficiency of heat exchange by 5%.

Increase the efficiency of system



- **Increase cooling power by 6%.**
- **Reduce refrigerant circulation amounts.**

PRECISE CONTROL

PID control adjusts the output of compressor and the open degree of EEV, balances the indoor refrigerant flow, realizes the linear output, creates a comfortable environment. The temperature can be controlled precisely.

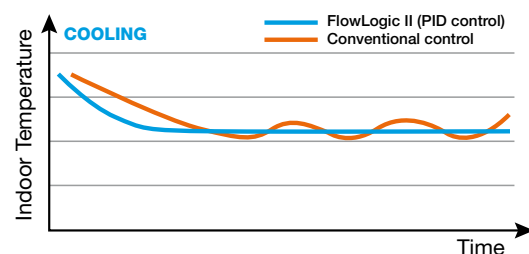



+ PRODUCTS

- COP can reach 4.2.
- Compact (0.32 m² footprint).
- Easy maintenance.

FEATURES



R410A FLUID



DC INVERTER

- Capacity range: 5 HP, 6 HP and 10 HP.
- Designed for residential use or for light commercial use.
- Minimum outdoor temperature for heating mode operation -15°C.
- Minimum outdoor temperature for cooling mode operation -5°C.
- DC Inverter compressor and ventilator.
- Refrigerant simple pipe length up to 300 m.
- Capacity ratio 50-130%.

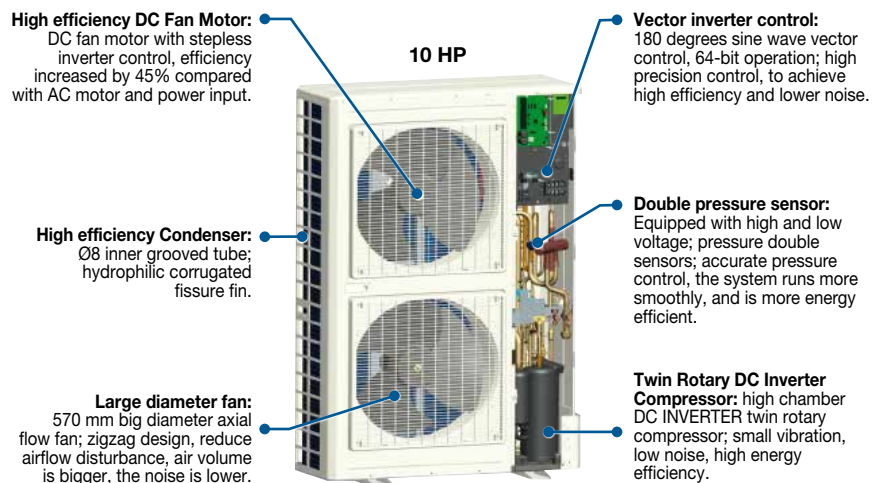
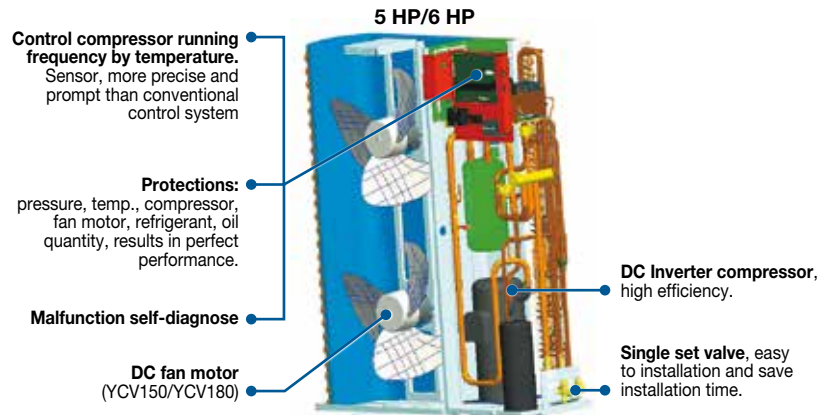

MINI FLOWLOGIC II TECHNICAL DATA

Outdoor units		AWAU-YCV150-H13	AWAU-YCV180-H13	AWAU-YCVFD280-H13
Code		7SP14H102	7SP14H013	7SP14H011
RATED POWERS				
Cooling	kW	15	18	28
Heating	kW	17	20	31.5
ELECTRICAL PARAMETERS				
Power supply	Ph/V/Hz	3P/400/50-N	3P/400/50-N	3P/400/50-N
Cooling rated power input	kW	4.2	5.5	8
Heating rated power input	kW	4.0	5.25	7.5
EER/COP		3.41/4.06	3.27/3.8	3.5/4.2
Max. current	A	9.6	11.3	23.4
PERFORMANCE				
Airflow (HS)	m ³ /h	6500	6500	10000
Noise level (HS)	dB(A)	59	60	58
INSTALLATION				
External dimensions (WxHxD)	mm	948x1250x340	948x1250x340	1050x1636x400
Shipping dimensions (WxHxD)	mm	1094x1400x410	1094x1400x410	1150x1790x510
Net weight/Gross weight	kg	118/128	130/140	168/183
Compressor type		Rotary	Rotary	Scroll
Refrigerant type		R410A	R410A	R410A
Refrigerant charge	kg	4.4	5.0	7.4
Liquid pipe diameter	inches	3/8"	3/8"	1/2"
Suction pipe diameter	inches	3/4"	3/4"	7/8"
Max. pipe length	m	100	100	300
Max. height between indoor and outdoor units*	m	30/20*	30/20*	50
Maximum indoor units connectable	quantity	8	9	16
OPERATING LIMITS				
Cooling	°C	-5/43	-5-43	-5-43
Heating	°C	-15/21	-15-21	-15-21

* 30 m if the outdoor unit is above indoor unit, 20 m if the outdoor unit is below indoor unit.



+ PRODUCTS

- COP can reach 4.45.
- Compact (0.97 m² footprint).
- Large capacity range (single and combination).
- DC Inverter compressor and ventilator.

FEATURES



R410A FLUID



DC INVERTER



HEATING MODE
OPERATIONAL DOWN
TO -23°C OUTDOORS



- Capacity range from 10 HP to 72 HP.
- Designed for all commercial uses.
- Minimum outdoor temperature for heating mode operation -23°C.
- Minimum outdoor temperature for cooling mode operation -5°C.
- Refrigerant simple pipe length up to 1000 m.
- Capacity ratio 50-130%.
- Eurovent.



HIGH MODULARITY: LONG PIPE LENGTH, HIGH HEIGHT DROP

Refrigerant simple
pipe length up to
1000 m

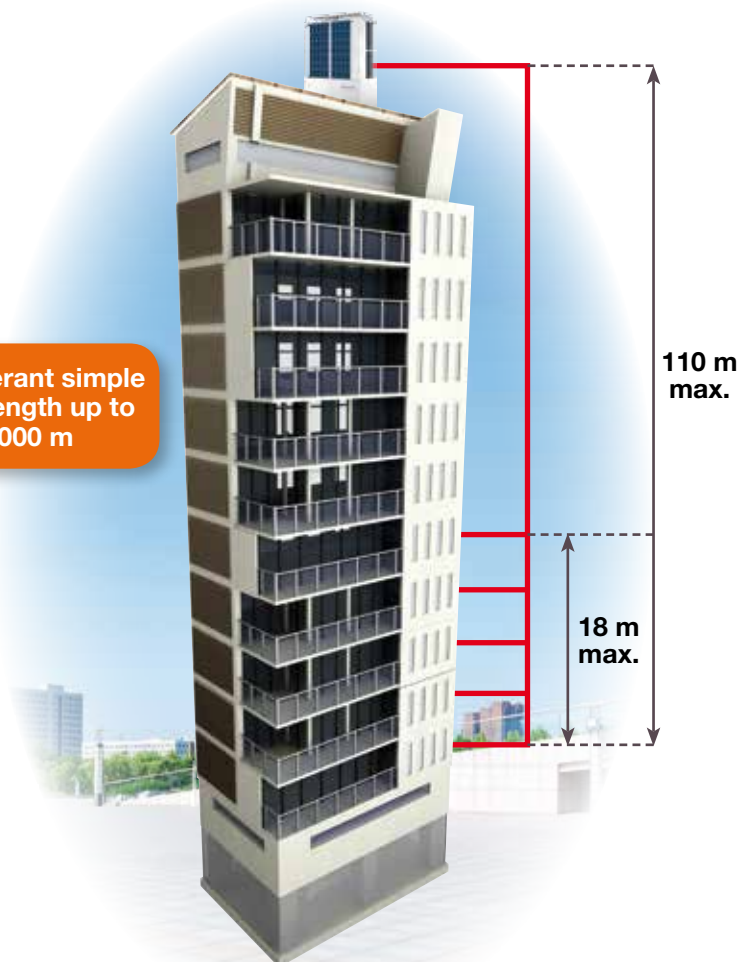

■ Single capacity and combination

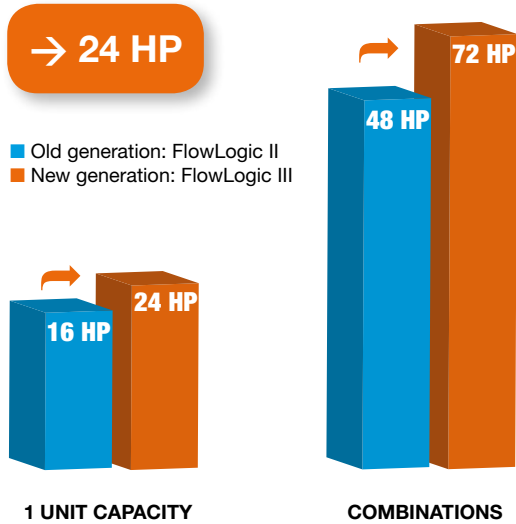

■ Floor area optimized for all the product range (same foot print for all modules: 0.97 m²)

One of the smallest footprint on market.



→ 0.97 m²

■ Full DC inverter

OLD GENERATION: FLOWLOGIC II	NEW GENERATION: FLOWLOGIC III
<p>DCI + Fixed speed</p>	<p>DCI + DCI</p>
<p>→ 1 x DC Inverter compressor → 1 x Fixed Speed compressor</p>	<p>→ 2 x Full DC Inverter</p>

- High static pressure outdoor unit:
82 Pa, long air duct



Hidden solution:
Installation of
outdoor unit in a
technical room

- Wide operation range

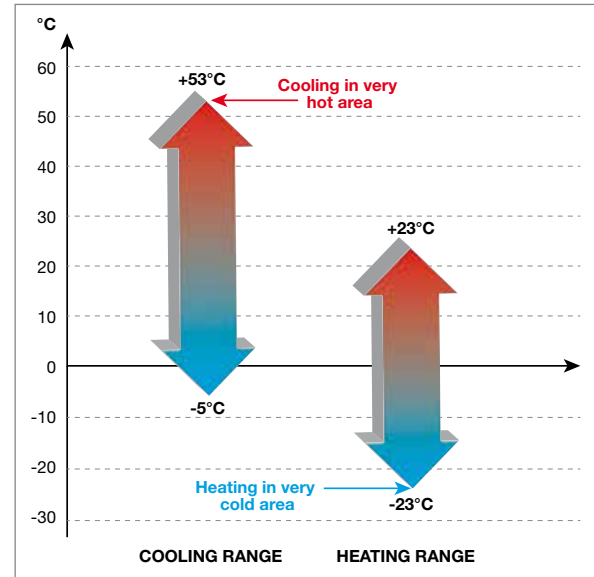

- New design/Full new outlook

→ **Specific design:**

- Double EEV
- Two-piece condenser
- Independent electrical box

→ **Reliability/Maintenance:**

- Compressor double protection: Two pressure sensors
- Double oil temperature sensor
- Large volume gas-liquid separator (26L) + liquid storage tank (10L)
- Two floor structure (no air bypass during maintenance): efficient measures

→ **Fan:**

- Optimized fan to reduce air vibration
- DC fan to optimize efficiency
- 82 Pa static pressure

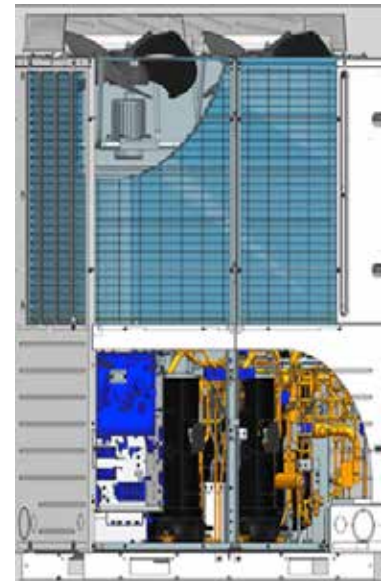

- Specific oil return

→ Magnetic valve

→ If the compressor operate at low frequency, oil return is only with capillary.

→ If the compressor operate at higher frequency, PCB control magnetic valve to improve oil return.

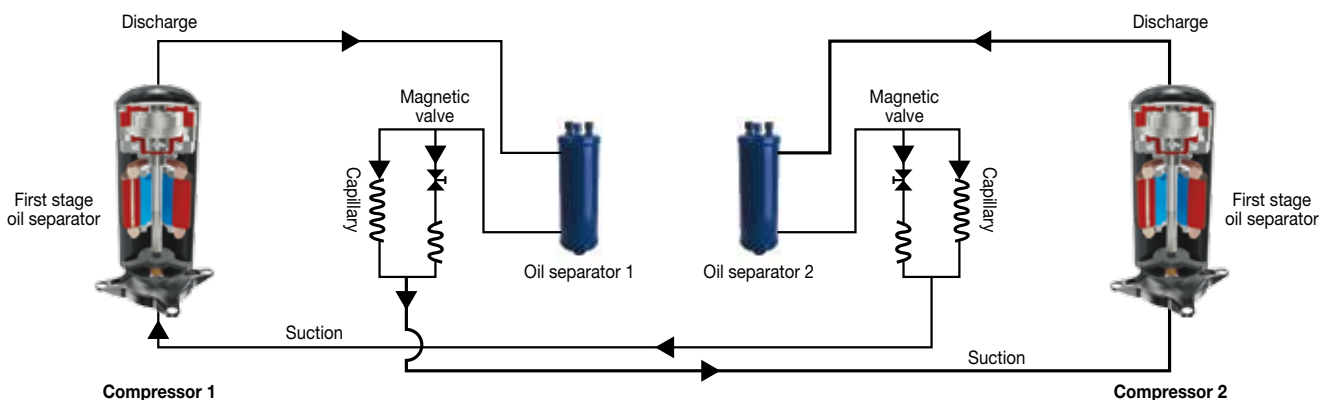

■ Reliability

→ Additional check valve

To extend life of EEV, a check valve is used. In summer, the refrigerant only pass through the check valve to reduce approximately 50% of EEV use. In winter, EEV are used normally.

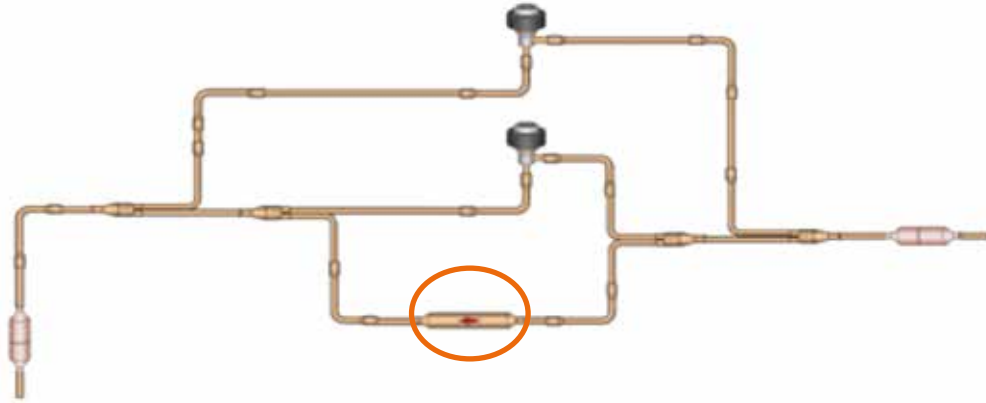

■ Regulation

- Change over via deep switch (priority heating/cooling mode)
- Low noise and at night silent running

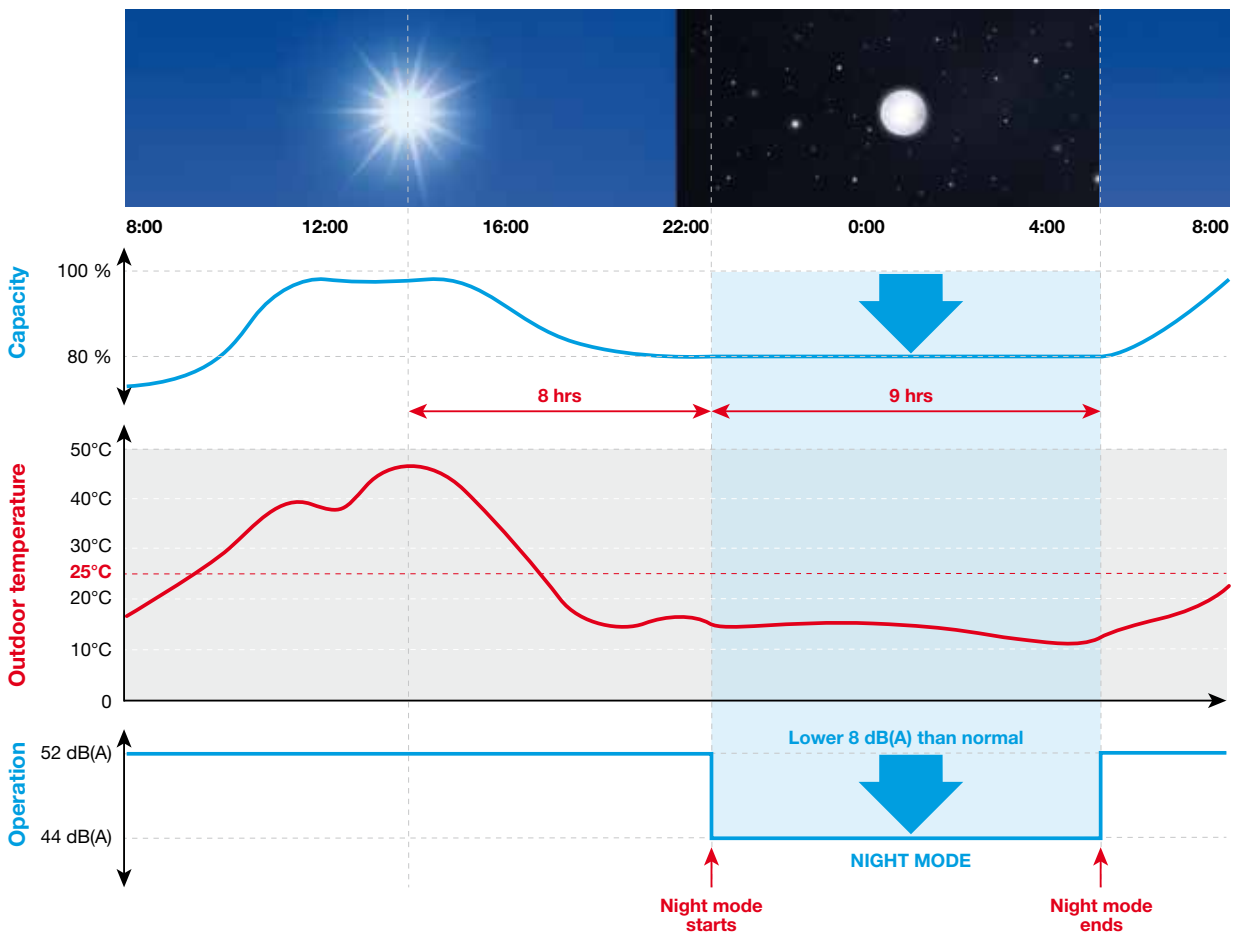



(certification in progress)

FLOWLOGIC III TECHNICAL DATA

Outdoor units		Drop only				Drop only				
		AWAU-YDV280-H13	AWAU-YDV335-H13	AWAU-YDV400-H13	AWAU-YDV450-H13	AWAU-YDV504-H13	AWAU-YDV560-H13	AWAU-YDV615-H13	AWAU-YDV680-H13	
Code		7SP14H030	7HP14H031	7SP14H032	7SP14H033	7SP14H034	7SP14H035	7HP14H036	7SP14H037	
										
POWERS										
Capacity range	HP	10	12	14	16	18	20	22	24	
Cooling	kW	28	33.5	40	45	50.4	56	61.5	68	
Heating	kW	31,5	37.5	45	50	56.5	63	69	73	
ELECTRICAL PARAMETERS										
Power supply	Ph/V/Hz	3/380~400/50/60-N								
Cooling	Rated power input	kW	7,00	8.59	10.26	11.90	13.62	15.56	17.57	19.71
	Power input max.	kW	14,38	14.73	16.91	22.68	22.10	25.19	30.56	37.47
	Rated current	A	11,56	14.19	16.94	19.66	22.50	25.69	29.02	32.55
	Current max.	A	23,68	25.1	28.40	36.80	36.15	41.10	49.65	60.65
Heating	Rated power input	kW	7,08	8.72	10.71	12.05	13.95	15.95	18.16	19.47
	Power input max.	kW	13,23	13.68	15.60	17.20	22.68	25.19	27.72	28.62
	Rated current	A	11,69	14.40	17.69	19.90	23.04	26.34	29.99	32.15
	Current max.	A	21,79	22.1	25.20	27.88	37.80	42.00	46.05	47.40
EER		4,00	3.90	3.90	3.78	3.70	3.60	3.50	3.45	
COP		4,45	4.30	4.20	4.15	4.05	3.95	3.80	3.75	
PERFORMANCES										
Airflow	Heating	m³/h	15000	15000	15000	15600	16200	16200	16200	16200
	Cooling	m³/h	13200	13200	13200	14400	15000	15000	15000	15000
Sound pressure level to 1 m	dB(A)	57	59	59.5	61	62	62	62	63	
Sound power level	dB(A)	73	75	76	77	79	79	79	80	
INSTALLATION										
Dimensions (WxHxD)	mm	1350x720x1690	1350x720x1690	1350x720x1690	1350x720x1690	1350x720x2048	1350x720x2048	1350x720x2048	1350x720x2048	
Refrigerant type		R410A								
Refrigerant charge	kg	9,7	9.7	10	10	10	10	10	10	
Net weight/Gross weight	kg	276/301	276/301	279/304	321/346	335/360	335/360	359/384	359/384	
Compressor type		Scroll								
Tubing	Liquid pipe diameter	inches	3/8"	1/2"	1/2"	1/2"	5/8"	5/8"	5/8"	5/8"
	Suction pipe diameter	inches	7/8"	1"	1"	1"1/8	1"1/8	1"1/8	1"1/8	1"1/8
	Oil equalization pipe	inches	3/8"	3/8"	3/8"	3/8"	3/8"	3/8"	3/8"	3/8"
	Max. tube length	meter	1000	1000	1000	1000	1000	1000	1000	1000
Max. height between indoor and outdoor units (ODU up/down)	m	50/40	50/40	50/40	50/40	50/40	50/40	50/40	50/40	
Max. height between indoor units	m	18	18	18	18	18	18	18	18	
External static pressure	Pa	82	82	82	82	82	82	82	82	
Environment temperature range	Cooling	°C	-5~50							
	Heating	°C	-23-21							
Maximum indoor units connectable	quantity	20	24	29	33	37	41	45	49	

TECHNICAL DATA FOR 14, 16, 18 & 20 HP TWO COMBINATIONS

Outdoor units	Drop only					
	YDV735-H13	YDV800-H13	YDV850-H13	YDV904-H13	YDV950-H13	YDV1010
Combinations part number	YDV335/ 7SP14H031	YDV400/ 7SP14H032	YDV400/ 7SP14H032	YDV400/ 7SP14H032	YDV450/ 7SP14H033	YDV450/ 7SP14H033
	YDV400/ 7SP14H032	YDV400/ 7SP14H032	YDV450/ 7SP14H033	YDV504/ 7SP14H034	YDV560/ 7SP14H034	YDV560/ 7SP14H035

POWERS

	HP	26	28	30	32	34	36
Capacity range	HP	26	28	30	32	34	36
Cooling	kW	73.5	80	85	90.4	95.4	101
Heating	kW	82.5	90	95	101.5	106.5	113

ELECTRICAL PARAMETERS

Power supply	Ph/V/Hz	3/380-400/50/60-N						
Cooling	Rated power input	kW	18.85	20.51	22.16	23.88	25.53	27.46
	Power input max.	kW	31.64	33.81	39.59.	39.00	44.78	47.87
	Rated current	A	31.12	33.88	36.60	39.43	42.16	45.35
	Current max.	A	53.5	56.80	65.20	64.55	72.95	77.90
Heating	Rated power input	kW	19.44	21.43	22.76	24.66	26.00	28.00
	Power input max.	kW	29.28	31.20	32.80	38.28	39.88	42.39
	Rated current	A	32.10	35.39	37.59	40.73	42.94	46.24
	Current max.	A	47.3	50.40	53.08	63.00	65.68	69.88
EER		3.90	3.90	3.84	3.79	3.74	3.68	
COP		4.24	4.20	4.17	4.12	4.10	4.04	

PERFORMANCES

Airflow	Heating	m³/h	30000	30000	30600	31200	31480	31480
Airflow	Cooling	m³/h	26400	26400	27600	28200	29400	29400
	Sound pressure level to 1 m	dB(A)	62	62.5	63	64	64.5	64.5
Sound power level	dB(A)	79	80	80	81	82	82	

INSTALLATION

Dimensions (WxHxD)	mm	(1350x720x1690)x2	(1350x720x1690)x2	(1350x720x1690)x2	1350x720x1690 + 1350x720x2048	1350x720x1690 + 1350x720x2048	1350x720x1690 + 1350x720x2048
Refrigerant type		R410A					
Refrigerant charge	kg	10+10	10+10	10+10	10+10	10+10	10+10
Net weight/Gross weight	kg	276/301 + 279/304	279/304 + 279/304	279/304 + 321/346	321/346 + 335/360	321/346 + 335/360	321/346 + 335/360
Compressor type		Scroll	Scroll	Scroll	Scroll	Scroll	Scroll
Tubing	Liquid pipe diameter	inches	3/4"	3/4"	3/4"	3/4"	3/4"
	Suction pipe diameter	inches	1"1/4	1"1/4	1"1/4	1"1/4	1"1/4
	Oil equalization pipe	inches	3/8"	3/8"	3/8"	3/8"	3/8"
	Max. tube length	meter	1000	1000	1000	1000	1000
Max. height between indoor and outdoor units (ODU up/down)	m	50/40	50/40	50/40	50/40	50/40	50/40
Max. height between indoor units	m	18	18	18	18	18	18
External static pressure	Pa	82	82	82	82	82	82
Environment temperature range	Cooling	°C	-5~50				
	Heating	°C	-23~21				
Maximum indoor units connectable	quantity	53	58	62	64	64	64

TECHNICAL DATA FOR 18, 20 & 24 HP TWO COMBINATIONS

Outdoor units	Drop only		Drop only		Drop only	
	YDV1064-H13	YDV1120-H13	YDV1175-H13	YDV1240-H13	YDV1295-H13	YDV1360-H13
Combinations part number	YDV504/ 7SP14H034	YDV560/ 7SP14H035	YDV560/ 7SP14H035	YDV560/ 7SP14H035	YDV615/ 7SP14H036	YDV680/ 7SP14H037
	YDV560/ 7SP14H035	YDV560/ 7SP14H035	YDV615/ 7SP14H036	YDV680/ 7SP14H037	YDV680/ 7SP14H037	YDV680/ 7SP14H037



POWERS

	HP	38	40	42	44	46	48
Capacity range							
Cooling	kW	106.4	112	117.5	124	129.5	136
Heating	kW	119.5	126	132	136	142	146

ELECTRICAL PARAMETERS

Power supply		Ph/V/Hz	3/380-400/50/60-N					
Cooling	Rated power input	kW	29.18	31.11	33.13	35.27	37.28	39.42
	Power input max.	kW	47.28	50.37	55.75	62.66	68.03	74.94
	Rated current	A	48.19	51.38	54.71	58.24	61.57	65.10
	Current max.	A	77.25	82.20	90.75	101.55	110.1	120.90
Heating	Rated power input	kW	29.90	31.90	34.11	35.42	37.62	38.93
	Power input max.	kW	47.87	50.37	52.91	53.81	56.34	57.24
	Rated current	A	49.38	52.68	56.33	58.49	62.14	64.30
	Current max.	A	19.80	84.00	88.05	89.40	93.45	94.80
EER			3.65	3.60	3.55	3.52	3.47	3.45
COP			4.00	3.95	3.87	3.84	3.77	3.75

PERFORMANCES

Airflow			32400	32400	32400	32400	32400	32400
Airflow	Heating	m³/h	32400	32400	32400	32400	32400	32400
	Cooling	m³/h	30000	30000	30000	30000	30000	30000
Sound pressure level to 1 m		dB(A)	65	65	65	65.5	65.5	66
Sound power level		dB(A)	83	83	83	83	83	84

INSTALLATION

Dimensions (WxHxD)		mm	(1350x720x2048) x2	(1350x720x2048) x2	(1350x720x2048) x2	(1350x720x2048) x2	(1350x720x2048) x2	(1350x720x2048) x2
Refrigerant type			R410A					
Refrigerant charge		kg	10+10	10+10	10+10	10+10	10+10	10+10
Net weight/Gross weight		kg	(335/360)x2	(335/360)x2	335/360 + 359/384	335/360 + 359/384	(359/384)x2	359/384 + 359/384
Compressor type			Scroll	Scroll	Scroll	Scroll	Scroll	Scroll
Tubing	Liquid pipe diameter	inches	3/4"	3/4"	3/4"	3/4"	3/4"	3/4"
	Suction pipe diameter	inches	1"1/4	1"1/4	1"1/4	1"1/4	1"1/4	1"1/4
	Oil equalization pipe	inches	3/8"	3/8"	3/8"	3/8"	3/8"	3/8"
	Max. tube length	meter	1000	1000	1000	1000	1000	1000
Max. height between indoor and outdoor units (ODU up/down)		m	50/40	50/40	50/40	50/40	50/40	50/40
Max. height between indoor units		m	18	18	18	18	18	18
External static pressure		Pa	82	82	82	82	82	82
Environment temperature range	Cooling	°C	-5~50					
	Heating	°C	-23-21					
Maximum indoor units connectable		quantity	64	64	64	64	64	64

TECHNICAL DATA FOR 14, 16, 18 & 20 HP THREE COMBINATIONS

Outdoor units	YDV1408-H13	YDV14602-H13	YDV1514-H13	YDV1570-H13
Combinations part number	YDV400/7SP14H032	YDV450/7SP14H033	YDV450/7SP14H033	YDV450/7SP14H033
	YDV504/7SP14H034	YDV450/7SP14H033	YDV504/7SP14H034	YDV560/7SP14H035
	YDV504/7SP14H034	YDV560/7SP14H035	YDV560/7SP14H035	YDV560/7SP14H035
				

POWERS

Capacity range	HP	50	52	54	56
Cooling	kW	140.8	146	151.4	157
Heating	kW	158	163	169.5	176

ELECTRICAL PARAMETERS

Power supply	Ph/V/Hz	3/380-400/50/60-N				
Cooling	Rated power input	kW	37.50	39.37	41.08	43.02
	Power input max.	kW	61.10	70.55	69.96	73.05
	Rated current	A	61.93	65.01	67.85	71.04
	Current max.	A	100.70	114.70	114.05	119.00
Heating	Rated power input	kW	38.62	40.05	41.95	43.95
	Power input max.	kW	60.96	59.59	65.07	67.57
	Rated current	A	63.77	66.14	69.28	72.58
	Current max.	A	100.80	97.76	107.68	111.88
EER		3.75	3.71	3.69	3.65	
COP		4.09	4.07	4.04	4.00	

PERFORMANCES

Airflow	Heating	m³/h	44440	44440	48000	48000
	Cooling	m³/h	43200	43480	44440	44440
Sound pressure level to 1 m		dB(A)	66	66	66.5	66.5
Sound power level		dB(A)	84	84	85	85

INSTALLATION

Dimensions (WxHxD)	mm	1350x720x(1690 + 1350x720x2048)x2	1350x720x(1690 + 1350x720x2048)x2	1350x720x(1690 + 1350x720x2048)x2	1350x720x(1690 + 1350x720x2048)x2	
Refrigerant type		R410A				
Refrigerant charge	kg	10+10+10	10+10+10	10+10+10	10+10+10	
Net weight/Gross weight	kg	279/304 + (335/360)x2	321/346 + (335/360)x2	321/346 + (335/360)x2	(335/360)x3	
Compressor type		Scroll	Scroll	Scroll	Scroll	
Tubing	Liquid pipe diameter	inches	3/4"	3/4"	3/4"	3/4"
	Suction pipe diameter	inches	1"1/2	1"1/2	1"1/2	1"5/8
	Oil equalization pipe	inches	3/8"	3/8"	3/8"	3/8"
	Max. tube length	meter	1000	1000	1000	1000
Max. height between indoor and outdoor units (ODU up/down)	m	50/40	50/40	50/40	50/40	
Max. height between indoor units	m	18	18	18	18	
External static pressure	Pa	82	82	82	82	
Environment temperature range	Cooling	°C	-5~50			
	Heating	°C	-23~21			
Maximum indoor units connectable	quantity	64	64	64	64	

TECHNICAL DATA FOR 18, 20 & 24 HP THREE COMBINATIONS

Outdoor units	Drop only			
	YDV1624-H13	YDV1680-H13	YDV1735-H13	YDV1800-H13
Combinations part number	YDV504/7SP14H034	YDV560/7SP14H035	YDV560/7SP14H035	YDV560/7SP14H035
	YDV560/7SP14H035	YDV560/7SP14H035	YDV560/7SP14H035	YDV560/7SP14H035
	YDV560/7SP14H035	YDV560/7SP14H035	YDV615/7SP14H036	YDV680/7SP14H037



POWERS

	HP	58	60	62	64
Capacity range					
Cooling	kW	162.4	168	173,5	180
Heating	kW	182.5	189	195	199

ELECTRICAL PARAMETERS

Power supply		Ph/V/Hz	3/380~400/50/60-N			
Cooling	Rated power input	kW	44.73	46.67	48,68	50.82
	Power input max.	kW	72.47	75.56	80,93	87.84
	Rated current	A	73.88	77.07	80,40	83.93
	Current max.	A	118.35	123.30	131,85	142.65
Heating	Rated power input	kW	45.85	47.85	50,06	51.37
	Power input max.	kW	73.05	75.56	78,09	78.99
	Rated current	A	75.72	79.02	82,67	84.83
	Current max.	A	121.80	126.00	130,05	131.40
EER			3.63	3.60	3,56	3.54
COP			3.98	3.95	3,90	3.87

PERFORMANCES

Airflow	Heating	m³/h	48600	48600	48600	48600
	Cooling	m³/h	45000	45000	45000	45000
Sound pressure level to 1 m		dB(A)	67	67	67	67
Sound power level		dB(A)	85	85	85	85

INSTALLATION

Dimensions (WxHxD)	mm	(1350x720x2048) x 3	(1350x720x2048) x 3	(1350x720x2048) x 2 + (1350x720x2048)	(1350x720x2048) x 3	
Refrigerant type		R410A				
Refrigerant charge	kg	10+10+10	10+10+10	10+10+10	10+10+10	
Net weight/Gross weight	kg	(335/360)x3	(335/360)x3	(335/360)x2 + (359/384)	(335/360)x2 + 359/384	
Compressor type		Scroll	Scroll	Scroll	Scroll	
Tubing	Liquid pipe diameter	inches	3/4"	3/4"	3/4"	3/4"
	Suction pipe diameter	inches	1"5/8	1"5/8	1"5/8	1"5/8
	Oil equalization pipe	inches	3/8"	3/8"	3/8"	3/8"
	Max. tube length	meter	1000	1000	1000	1000
Max. height between indoor and outdoor units (ODU up/down)	m	50/40	50/40	50/40	50/40	
Max. height between indoor units	m	18	18	18	18	
External static pressure	Pa	82	82	82	82	
Environment temperature range	Cooling	°C	-5~50			
	Heating	°C	-23~21			
Maximum indoor units connectable	quantity	64	64	64	64	

TECHNICAL DATA FOR 18, 20 & 24 HP THREE COMBINATIONS

Outdoor units	Drop only		Drop only	
	YDV1855-H13	YDV1920-H13	YDV1975-H13	YDV2040-H13
Combinations part number	YDV560/7SP14H035	YDV560/7SP14H035	YDV615/7SP14H036	YDV680/7SP14H037
	YDV615/7SP14H036	YDV680/7SP14H037	YDV680/7SP14H037	YDV680/7SP14H037
	YDV680/7SP14H037	YDV680/7SP14H037	YDV680/7SP14H037	YDV680/7SP14H037



POWERS

	HP	66	68	70	72
Capacity range	HP	66	68	70	72
Cooling	kW	185.5	192	197.5	204
Heating	kW	205	209	215	219

ELECTRICAL PARAMETERS

Power supply		Ph/V/Hz	3/380-400/50/60-N			
Cooling	Rated power input	kW	52.84	54.98	56.99	59.13
	Power input max.	kW	93.22	100.13	105.50	112.41
	Rated current	A	87.26	90.79	94.12	97.65
	Current max.	A	151.2	162.00	170.55	181.35
Heating	Rated power input	kW	53.57	54.88	57.09	58.40
	Power input max.	kW	81.53	82.43	84.96	85.86
	Rated current	A	88.48	90.64	94.29	96.45
	Current max.	A	135.45	136.80	140.85	142.20
EER			3.51	3.49	3.47	3.45
COP			3.83	3.81	3.77	3.75

PERFORMANCES

Airflow	Heating	m³/h	48600	48600	48600	48600
	Cooling	m³/h	45000	45000	45000	45000
Sound pressure level to 1 m		dB(A)	67	67.5	67.5	67.5
Sound power level		dB(A)	85	86	86	86

INSTALLATION

Dimensions (WxHxD)		mm	(1350x720x2048) x 3	(1350x720x2048) x 3	(1350x720x2048) x 3	(1350x720x2048) x 3
Refrigerant type			R410A			
Refrigerant charge		kg	10+10+10	10+10+10	10+10+10	10+10+10
Net weight/Gross weight		kg	(335/360)x2 + 359/384	335/360 + (359/384)x2	335/360 + (359/384)x2	335/360 + (359/384)x2
Compressor type			Scroll	Scroll	Scroll	Scroll
Tubing	Liquid pipe diameter	inches	7/8"	7/8"	7/8"	7/8"
	Suction pipe diameter	inches	1"3/4	1"3/4	1"3/4	1"3/4
	Oil equalization pipe	inches	3/8"	3/8"	3/8"	3/8"
	Max. tube length	meter	1000	1000	1000	1000
Max. height between indoor and outdoor units (ODU up/down)		m	50/40	50/40	50/40	50/40
Max. height between indoor units		m	18	18	18	18
External static pressure		Pa	82	82	82	82
Environment temperature range	Cooling	°C	-5~50			
	Heating	°C	-23~21			
Maximum indoor units connectable		quantity	64	64	64	64



NEW

+ PRODUCTS

- Quiet.
- 3D and long distance air supply.
- Hidden screen.
- Two sides drain.



RCV02



RWW05
(optional)



RWW03
(optional)



RWW07
(optional)

FEATURES



R410A FLUID

- EEV inside: for an easier installation.
- High-quality DC fan motor: Reduce the indoor unit noise greatly.
- Fashion design.
- Infrared remote controller included.

HBV TECHNICAL DATA

Indoor units		AWSI- HBV007-N11	AWSI- HBV009-N11	AWSI- HBV012-N11	AWSI- HBV018-N11	AWSI- HBV024-N11
Code		7SP02H012	7SP02H013	7SP02H014	7SP02H015	7SP02H016
RATED POWERS						
Cooling	kBtu/h	7.5	9.5	12.3	19.1	24.2
	kW	2.2	2.8	3.6	5.6	7.1
Heating	kBtu/h	8.5	10.9	13.6	21.5	27.3
	kW	2.5	3.2	4	6.3	8
ELECTRICAL PARAMETERS						
Power supply	Ph/V/Hz	1/220-230/50	1/220-230/50	1/220-230/50	1/220-230/50	1/220-230/50
PERFORMANCE						
Airflow	m ³ /h	600	600	600	800	1000
Noise level (LS/MS/HS)	dB(A)	31/33/37	31/34/37	33/36/41	34/39/43	38/42/47
INSTALLATION						
External dimensions (WxHxD)	mm	938x265x187	938x265x187	938x265x187	1046x299x234	1046x299x234
Shipping dimensions (WxHxD)	mm	1016x360x304	1016x360x304	1016x360x304	1126x388x344	1126x388x344
Net weight/Gross weight	kg	10.9/12.6	10.9/12.6	10.9/12.6	13/16.5	13/16.5
Liquid pipe diameter	inches	1/4"	1/4"	1/4"	3/8"	3/8"
Suction pipe diameter	inches	1/2"	1/2"	1/2"	5/8"	5/8"

Dimensions: 007-009-012-018-024 models

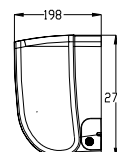
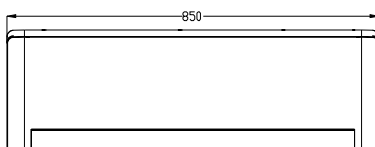

CBV

CASSETTE 600x600

Airwell
Just feel well



- Easy installation in false ceiling.
- Super quiet due to special fan design.
- Built-in high head pump (height up to 600 mm).
- Possible connection to a ventilation network due to a fresh air inlet (10-15% max).
- Dry contact: hotel/bungalow solutions (room card or on/off contact).

CBV TECHNICAL DATA

Indoor units		AWSI-CBV007-N11	AWSI-CBV009-N11	AWSI-CBV012-N11	AWSI-CBV016-N11
Code		7SP04H000	7SP04H001	7SP04H002	7SP04H003
RATED POWERS					
Cooling	kBtu/h	7.5	9.5	12.3	15.3
	kW	2.2	2.8	3.6	4.5
Heating	kBtu/h	8.5	10.9	13.6	17.1
	kW	2.5	3.2	4	5
ELECTRICAL PARAMETERS					
Power supply	Ph/V/Hz	1/220-230/50	1/220-230/50	1/220-230/50	1/220-230/50
PERFORMANCE					
Airflow	m ³ /h	700	700	700	700
Noise level (LS/MS/HS)	dB(A)	29/30/32	29/30/32	29/30/32	29/30/33
INSTALLATION					
External dimensions (WxHxD)	mm	570x570x260	570x570x260	570x570x260	570x570x260
Shipping dimensions (WxHxD)	mm	718x680x380	718x680x380	718x680x380	718x680x380
Net weight/Gross weight	kg	17/21	19/21	19/21	19/21
Liquid pipe diameter	inches	1/4"	1/4"	1/4"	1/4"
Suction pipe diameter	inches	3/8"	3/8"	1/2"	1/2"
FRAME					
Part number frame		7ACVFH001	7ACVFH001	7ACVFH001	7ACVFH001
External dimensions (WxHxD)	mm	700x700x60	700x700x60	700x700x60	700x700x60
Shipping dimensions (WxHxD)	mm	740x750x115	740x750x115	740x750x115	740x750x115
Net weight/Gross weight	kg	2.8/4.5	2.8/4.8	2.8/4.8	2.8/4.8

Dimensions: 007-009-012-016 models

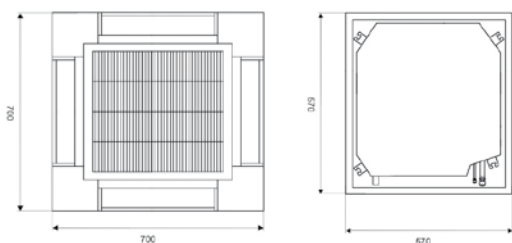

+ PRODUCTS

- Quiet operation.
- Built-in high head drain pump.
- Fresh air inlet.
- Wired controller RWW05 included.
- EEV inside.
- Automatic swing.



RWW05



RCV02 (optional)



RWW03 (optional)



RWW07 (optional)

FEATURES



R410A FLUID



+ PRODUCTS

- Compact design.
- Advance structure facilitating cleaning and installation.
- Fresh air inlet.
- EEV inside.
- Wired controller RWW05 included.
- Automatic swing.
- IR receipt included.



RWW05



RCV02 (optional)



RWW03 (optional)



RWW07 (optional)

FEATURES



R410A FLUID

- Easy installation in false ceiling.
- Possible connection to a ventilation network due to a fresh air inlet (10-15% max).
- Built-in high head pump (height up to 600 mm).
- Better comfort due to its high air flow.
- Dry contact: hotel/bungalow solutions (room card or on/off contact).

CCV TECHNICAL DATA

Indoor units		AWSI-CCV018-N11	AWSI-CCV024-N11	AWSI-CCV030-N11	AWSI-CCV048-N11
Code		7SP04H004	7SP04H005	7SP04H007	7SP04H009
RATED POWERS					
Cooling	kBtu/h	19.1	24.2	30.7	47.7
	kW	5.6	7.1	9	14
Heating	kBtu/h	21.5	27.3	34.1	54.6
	kW	6.3	8	10	16
ELECTRICAL PARAMETERS					
Power supply	Ph/V/Hz	1/220-230/50	1/220-230/50	1/220-230/50	1/220-230/50
PERFORMANCE					
Airflow	m ³ /h	1200	1200	1800	1800
Noise level (LS/MS/HS)	dB(A)	30/32/34	31/35/34	31/35/37	35/39/42
INSTALLATION					
External dimensions (WxHxD)	mm	840x840x240	840x840x240	840x840x295	840x840x295
Shipping dimensions (WxHxD)	mm	930x930x330	930x930x330	930x930x390	930x930x390
Net weight/Gross weight	kg	30/36	30/36	38/40	38/40
Liquid pipe diameter	inches	1/4"	3/8"	3/8"	3/8"
Suction pipe diameter	inches	1/2"	5/8"	5/8"	5/8"
FRAME					
Part number frame		7ACVFH002	7ACVFH002	7ACVFH002	7ACVFH002
External dimensions (WxHxD)	mm	950x950x80	950x950x80	950x950x80	950x950x80
Shipping dimensions (WxHxD)	mm	985x985x115	985x985x115	985x985x115	985x985x115
Net weight/Gross weight	kg	6/9	6/9	6/9	6/9

Dimensions: 018-024-030-048 models

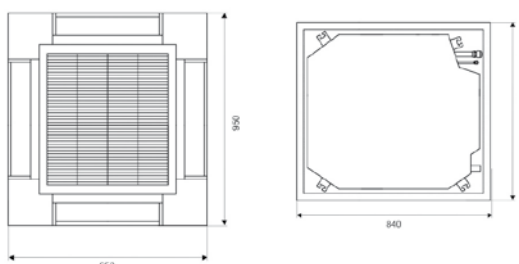



- Precise control of the air flow via wide angle louvers.
- Floor & ceiling installation.
- Long distance air throw.
- Dry contact: hotel/bungalow solutions (room card or on/off contact).

FAV TECHNICAL DATA

Indoor units		AWSI-FAV012-N11	AWSI-FAV018-N11	AWSI-FAV024-N11
Code		7SP02H008	7SP02H010	7SP02H011
RATED POWERS				
Cooling	kBtu/h	12.3	19.1	24.2
	kW	3.6	5.6	7.1
Heating	kBtu/h	13.6	21.5	27.3
	kW	4	6.3	8
ELECTRICAL PARAMETERS				
Power supply	Ph/V/Hz	1/220-230/50	1/220-230/50	1/220-230/50
PERFORMANCE				
Airflow (LS/MS/HS)	m ³ /h	580/710/800	580/710/800	580/710/800
Noise level (LS/MS/HS)	dB(A)	33/35/38	35/37/40	35/37/40
INSTALLATION				
External dimensions (WxHxD)	mm	990x665x199	990x655x199	990x665x199
Shipping dimensions (WxHxD)	mm	1150x750x300	1150x750x300	1150x750x300
Net weight/Gross weight	kg	28.3/34.3	28.3/34.3	28.3/34.3
Liquid pipe diameter	inches	1/4"	1/4"	3/8"
Suction pipe diameter	inches	1/2"	1/2"	5/8"

Dimensions: 012-018-024 models

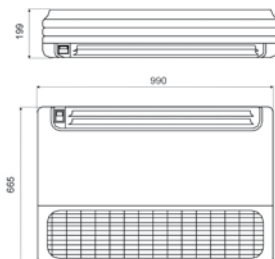

+ PRODUCTS

- Ultra-thin unit body, only thick 199 mm.
- Wide-angle airflow.
- Quiet running.
- EEV inside.
- Wired controller RWW05 included.
- Automatic swing.



RWW05



RCV02 (optional)



RWW03 (optional)



RWW07 (optional)

FEATURES



R410A FLUID



DAV 007-009-012



DAV 016

UPGRADE

+ PRODUCTS

- 220 ultra thin design and space saving.
- Optional air return design.
- High efficiency filter G3.
- EEV inside.
- Wired controller RWW05 included on standard.
- Ideal for hotel.



RWW05



RCV02
(optional)



(infrared receiver to combined with RCV 01)



RWW03
(optional)



RWW07
(optional)

FEATURES



R410A FLUID

- Invisible solution.
- Two choices of static pressure: Better fitting with aeraulic network.
- Wide range: new size 7.
- Dry contact: hotel/bungalow solutions (room card or on/off contact).

DAV TECHNICAL DATA

Indoor unit		AWSI-DAV007-N11	AWSI-DAV009-N11	AWSI-DAV012-N11	AWSI-DAV016-N11
Code		7SP03H001	7SP03H002	7SP03H003	7SP03H004
RATED POWERS					
Cooling	kBtu/h	7.5	9.5	12.3	15.3
	kW	2.2	2.8	3.6	4.5
Heating	kBtu/h	8.5	10.9	13.6	17.1
	kW	2.5	3.2	4	5
ELECTRICAL PARAMETERS					
Power supply	Ph/V/Hz	1/220-230/50	1/220-230/50	1/220-230/50	1/220-230/50
PERFORMANCE					
Airflow	m³/h	400	400	500	850
Noise level (LS/MS/HS)	dB(A)	30/32/35	30/32/35	30/32/35	30/32/35
INSTALLATION					
External dimensions (WxHxD)	mm	610x220x500	610x220x500	610x220x500	1105x220x500
Shipping dimensions (WxHxD)	mm	710x280x549	710x280x549	710x280x549	1174x294x549
Net weight/Gross weight	kg	15/17	15/17	16/19	25/27
Liquid pipe diameter	inches	1/4"	1/4"	1/4"	1/4"
Suction pipe diameter	inches	3/8"	3/8"	3/8"	3/8"
Static pressure	Pa	20	20	20	20

Dimensions: 007-009-012 models

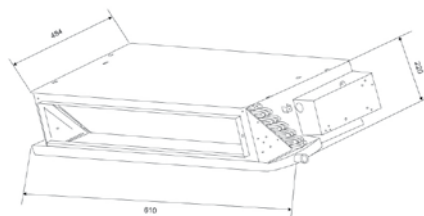

Dimensions: 016 model

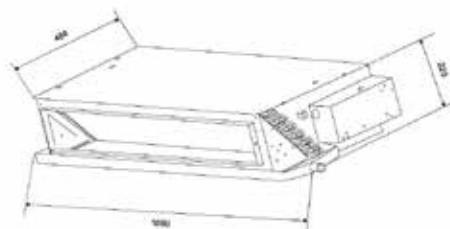

DBV DUCTED MEDIUM STATIC PRESSURE



- Invisible solution.
- Two choices of static pressure: Better fitting with aeraulic network.
- Built-in high head pump (height up to 600 mm).
- Plenum for air outlet provided: 3 Ø200 sizes 018 and 028, 4 Ø200 size 038.
- Dry contact: hotel/bungalow solutions (room card or on/off contact).



DBV TECHNICAL DATA

Indoor units		AWSI-DBV018-N11	AWSI-DBV024-N11	AWSI-DBV028-N11	AWSI-DBV038-N11
Code		7SP03H007	7SP03H008	7SP03H009	7SP03H011
RATED POWERS					
Cooling	kBtu/h	19.1	24.2	27.3	38.2
	kW	5.6	7.1	8	11.2
Heating	kBtu/h	21.5	27.3	30.7	42.6
	kW	6.3	8	9	12.5
ELECTRICAL PARAMETERS					
Power supply	Ph/V/Hz	1/220-230/50	1/220-230/50	1/220-230/50	1/220-230/50
PERFORMANCE					
Airflow	m³/h	1200	1200	1200	1900
Noise level (LS/MS/HS)	dB(A)	35/37/43	35/37/43	35/37/43	35/37/43
INSTALLATION					
External dimensions (WxHxD)	mm	990x650x300	990x650x300	990x650x300	1410x645x350
Shipping dimensions (WxHxD)	mm	1167x860x345	1167x860x345	1167x860x345	1557x800x370
Net weight/Gross weight	kg	39/45	39/45	39/45	59/66
Liquid pipe diameter	inches	1/4"	3/8"	3/8"	3/8"
Suction pipe diameter	inches	1/2"	5/8"	5/8"	5/8"
Static pressure	Pa	50	50	50	50
Max. static pressure	Pa	96	96	96	96

Dimensions: 018-024-028 models

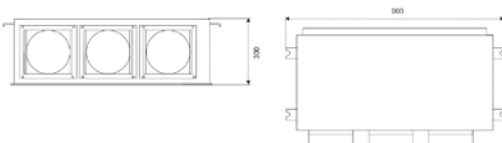

Dimensions: 038 model

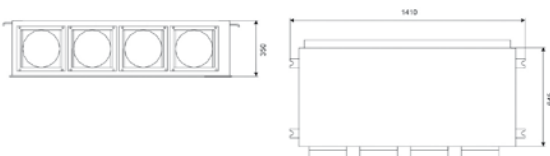

+ PRODUCTS

- Flexible static pressure selection, meeting the customers' personal requests.
- High efficiency filter G3.
- Special up-drainage water pump.
- EEV inside.
- Wired controller RWW05 included.



RWW05



RCV02 (optional)



(infrared receiver to combined with RCV 02)



RWW03 (optional)



RWW07 (optional)

FEATURES



R410A FLUID



DCV 048



DCV 072-096

+ PRODUCTS

- High efficiency filter.
- Free setting of air discharge duct.
- Multi install mode.
- High external static pressure design.



RWW05



RCV02
(optional)



RWW03
(optional)



RWW07
(optional)

FEATURES



R410A FLUID

- Invisible solution.
- Static pressure up to 196 Pa.
- Commercial application: high air flow and capacity up to 28 kW.
- Compatible with a textile duct application.



DCV TECHNICAL DATA

Indoor unit		AWSI-DCV048-N11	AWSI-DCV072-N11	AWSI-DCV096-N11
Code		7SP03H018	7SP03H019	7SP03H020
RATED POWERS				
Cooling	kBtu/h	47.7	77.1	95.5
	kW	14	22.6	28
Heating	kBtu/h	54.6	85.3	108.5
	kW	16	25	31.5
ELECTRICAL PARAMETERS				
Power supply	Ph/V/Hz	1/220-230/50	1/220-230/50	1/220-230/50
PERFORMANCE				
Airflow	m ³ /h	2100	4050	4050
Noise level (LS/HS)	dB(A)	40/45	49/54	49/54
INSTALLATION				
External dimensions (WxHxD)	mm	1197x360x830	1570x360x880	1570x360x880
Shipping dimensions (WxHxD)	mm	1430x420x940	1800x525x1000	1800x525x1000
Net weight/Gross weight	kg	62/77	100/111	100/111
Liquid pipe diameter	inches	3/8"	3/8"	3/8"
Suction pipe diameter	inches	5/8"	1"	1"
Static pressure	Pa	196	196	196

Dimensions: 048 model

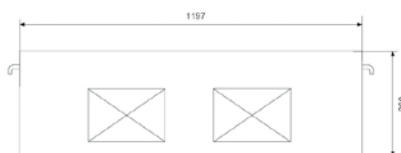

Dimensions: 072-096 models





- Esthetic and compact design.
- Ideal solution to replace electric heaters.
- Blowing up and down.
- Dry contact: hotel/bungalow solutions (room card or on/off contact).

EAV TECHNICAL DATA

Indoor unit		AWSI-EAV012-N11
Code		7SP05H002
RATED POWERS		
Cooling	kBtu/h	12.3
	kW	3.6
Heating	kBtu/h	13.6
	kW	4
ELECTRICAL PARAMETERS		
Power supply	Ph/V/Hz	1/220-230/50
PERFORMANCE		
Airflow	m³/h	520
Noise level (LS/MS/HS)	dB(A)	36/39/43
INSTALLATION		
External dimensions (WxHxD)	mm	762x640x253
Shipping dimensions (WxHxD)	mm	784x719x305
Net weight/Gross weight	kg	18/20
Liquid pipe diameter	inches	1/4"
Suction pipe diameter	inches	1/2"

+ PRODUCTS

- High efficiency filter.
- Quiet running.
- Compact unit body and space saving.
- EEV inside.
- Wireless controller included.



RCV02

FEATURES



R410A FLUID

Dimensions: 012 model

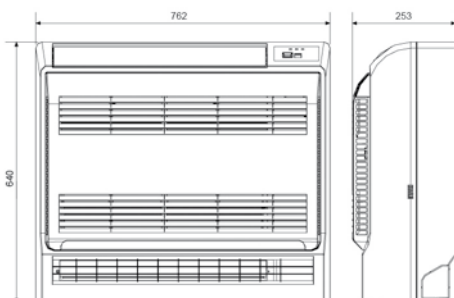

AHU Connection Kit

Airwell offers a range of connection kits to connect VRF outdoor units to third party DX air handling units.

■ CONFIGURATION BETWEEN 14 AND 28 KW

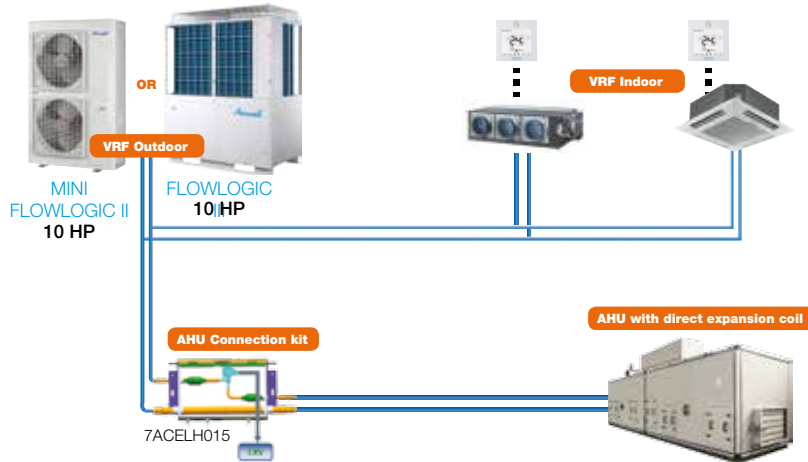

5 HP (14 kW) < Connected AHU capacity ≤ 10 HP (28 kW)

AHU and direct expansion coil to be purchased through other supplier

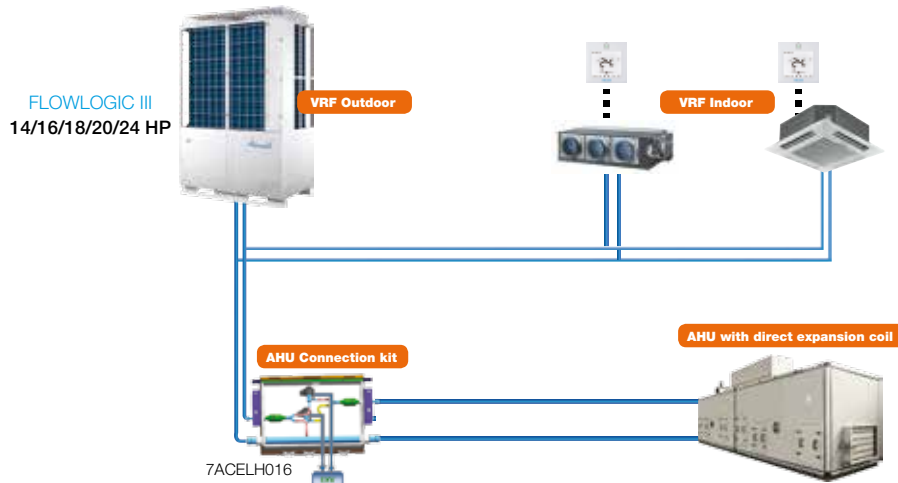

■ CONFIGURATION BETWEEN 28 AND 56 KW



10 HP (28 kW) < Connected AHU capacity ≤ 20 HP (56 kW)

AHU and direct expansion coil to be purchased through other supplier

VRF OUTDOOR LINE UP

OUTDOOR	MINI FLOWLOGIC II	FLOWLOGIC III
Modèle	All range	All range
		
Power supply	3/380~400V/50Hz 3/380~400V/60Hz	3/380~400V/50Hz/3/380~400V/60Hz 3/220V/60Hz/3/460V/60Hz
AHU kit	7ACELH015 5 HP (14 kW) < Connected AHU capacity ≤ 10 HP (28 kW)	7ACELH016 10 HP (28 kW) < Connected AHU capacity ≤ 20 HP (56 kW)

SYSTEM APPLICATION

- Provides a solution for big space to cool down the supplied fresh air with VRF outdoor units to match the air handling units. Integrates all advantages of VRF and AHU units.
- EU legislation requires that every working place has to be supplied with a minimum of 25 m³/h/person of fresh air. So it means that every office, every shop and mostly every commercial building MUST have this solution in order to comply with the standard.



Buildings



Shopping centres



Hospitals

AHU KIT CONFIGURATION

Airwell AHU Connection Kit consists in the following 4 parts:



Different Valve ▼ Same Control Parts

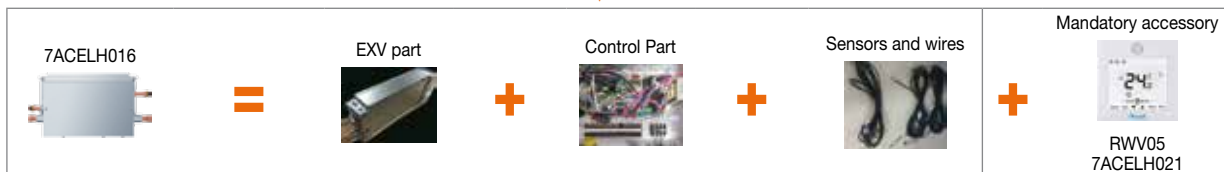

- EXV part, Control part, Sensor and wire are all integrated in one box.
- Controller need to be purchased separately.
- Temperature control via outlet air sensor on AHU.

WIRING DIAGRAM

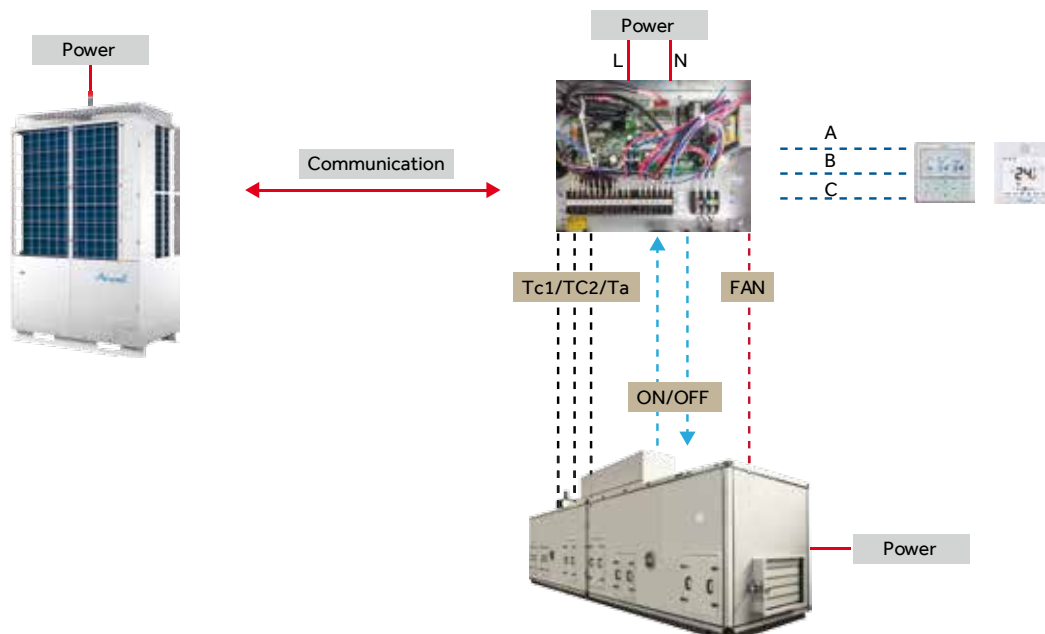

CONNECTION KIT CONTROL

Central Control: AHU control is same as VRF indoor unit control.

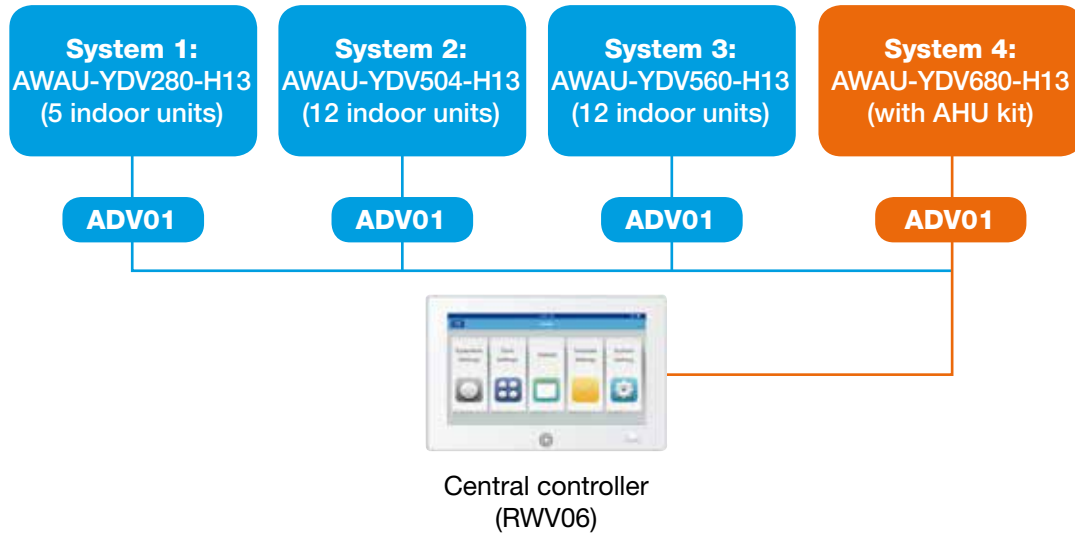

Easy Installation

- AHU can provide enough cooled fresh air to big spaces other than HRV and fresh air indoor units.
- All the control system for VRF outdoor is available:
 - Wired control
 - Central control
 - Net work control
 - BMS control

ADVANTAGES & SPECIFICATIONS

- Connected AHU capacity from 5HP to 20HP.
- Highly Compatible 1. Same PCB board with VRF indoor, easy operation and service.
- Same wired controller can be used with VRF indoor unit.

Central control solutions

TOUCH SCREEN CENTRAL REMOTE CONTROL RWV06

Can control and monitor the indoor units conditions, with a maximum of 128 groups, each group connected to a maximum of 16 indoor units (256 indoor units max). All the controls, such as individual control, zone control, time setting, timer setting etc., can be performed on touch screen. Connecting diagram as follows:



Main functions are:

- Can monitors 128 groups (max) of indoor units (operation mode, airflow speed, temperature, setting, ON/OFF, error code display, eco mode, backup system data...).
- Program mode, airflow speed, temp., etc. for individual/zone/all.
- Checks indoor unit real temp., pipe temp. etc. parameters.
- Sets LIFO (Last enter have high priority), central control, lock, etc., 3 types of operation modes.
- Monitors the indoor units malfunctions and save the error codes for future checking.
- Weekly timer setting.
- Sets random units groups to one zone, with a maximum of 128 groups for one zone. When a zone is set, each indoor unit in this zone can have a same operation status (default setting: one group is one zone).

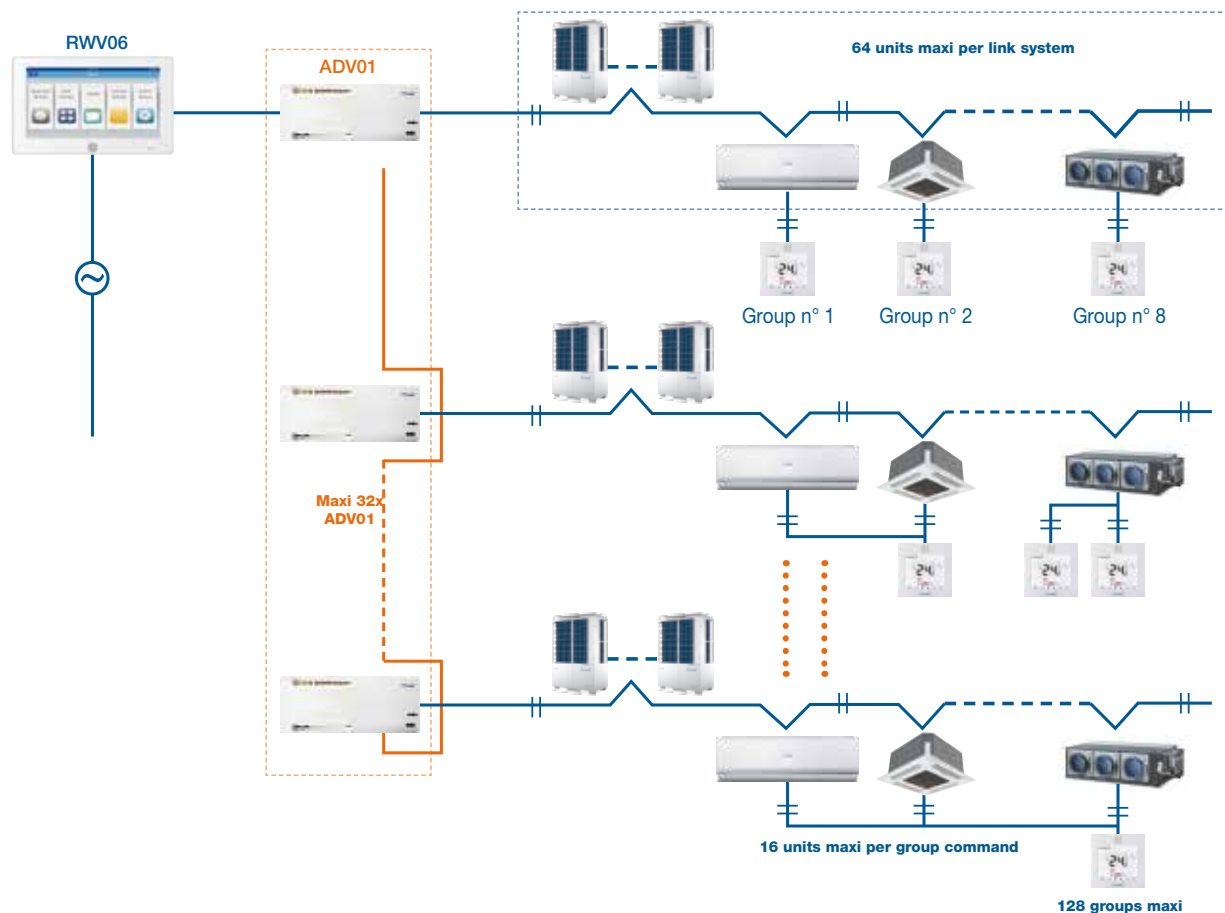

Part number RWV06: 7ACELH023

AIRWELL BMS CONTROL (BUILDING MODELLING SYSTEM)

BMS system transfers the data of air conditioner to the computer through the inverter protocol adapter (ADV02), and then the user can:

- Monitor the operation status and the power consumption of indoor and outdoor units in real time on a computer interface.
- Set the system parameters in real time.
- Start or stop each indoor unit individually or a group as per request.
- Receive the alarms and perform measurements in real time.
- Deal with the data and produces some costs and account reports.

Max. 32 ADV02 can be connected and 40 indoor units by one inverter protocol adapter (ADV02) (so a total of 1280 indoor units).

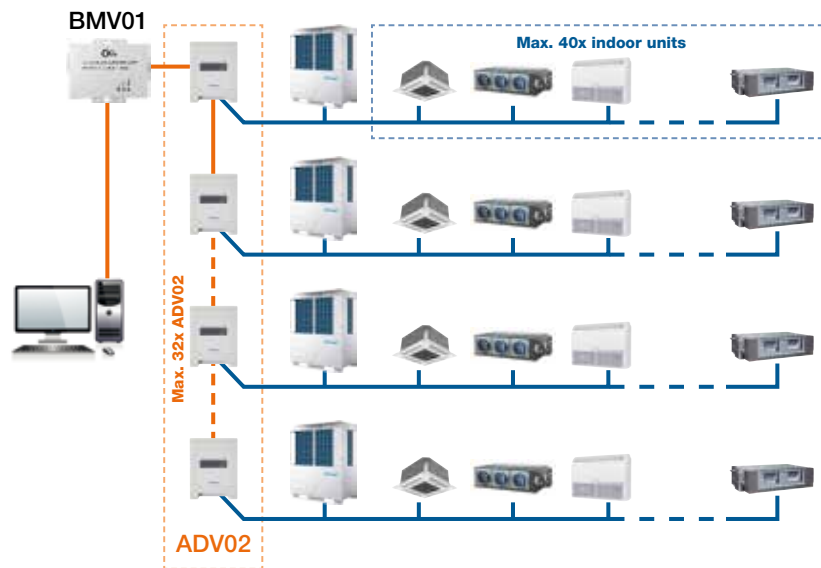

APPLICABLE FOR VRF SYSTEM

■ System combination

- Inverter protocol adapter (ADV02): Transforms the air conditioner protocol into protocol 485; receives ammeter pulse signal; accounts and saves the power cost of the connected system, then transfers it to the computer.
- Software: displays all parameters, offers a comfortable human computer interface, calculates and records power costs for accounting reports.
- RS 485&232 converter (hardware), Item 2 & 3 name is BMV01.

■ Control range

- Pay attention that the indoor quantity of every system cannot be over 40 sets or the adapter will not work normally.
- Every system needs one protocol adapter.
- One computer can control indoors within 400 sets.

APPLICABLE RANGE AND RELATIVE CERTIFICATE

■ Applicable range

- Temp. range: -30°C~52°C
- Ambient temperature of controller: -30°C~52°C
- Ambient humidity of controller: 10%~85%
- Save temp. range of controller: -30°C~52°C
- Altitude: 0~6000m
- Voltage: 220Vac±10%
- Frequency: 50Hz

Part number ADV02: 7ACELH007
Part number BMV01: 7ACELH005

BACNET BMS CONTROL

BMV03 Network Airwell A/C management system

- Total actual connected indoor units quantity is max. 1000.
- Internet remote control.
- To be purchased through external supplier by dealer/customer:
 - computer display,
 - energy pulse meter and printer if calculations power consumption are required.
- Interface: BACnet.

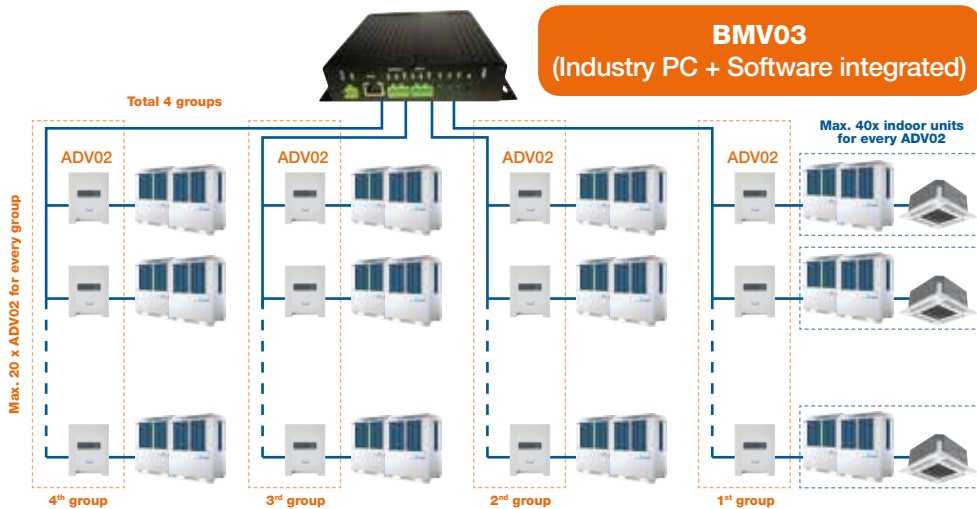

Part number BMV03: 7ACELH013
 Part number ADV02: 7ACELH007

MODBUS BMS CONTROL

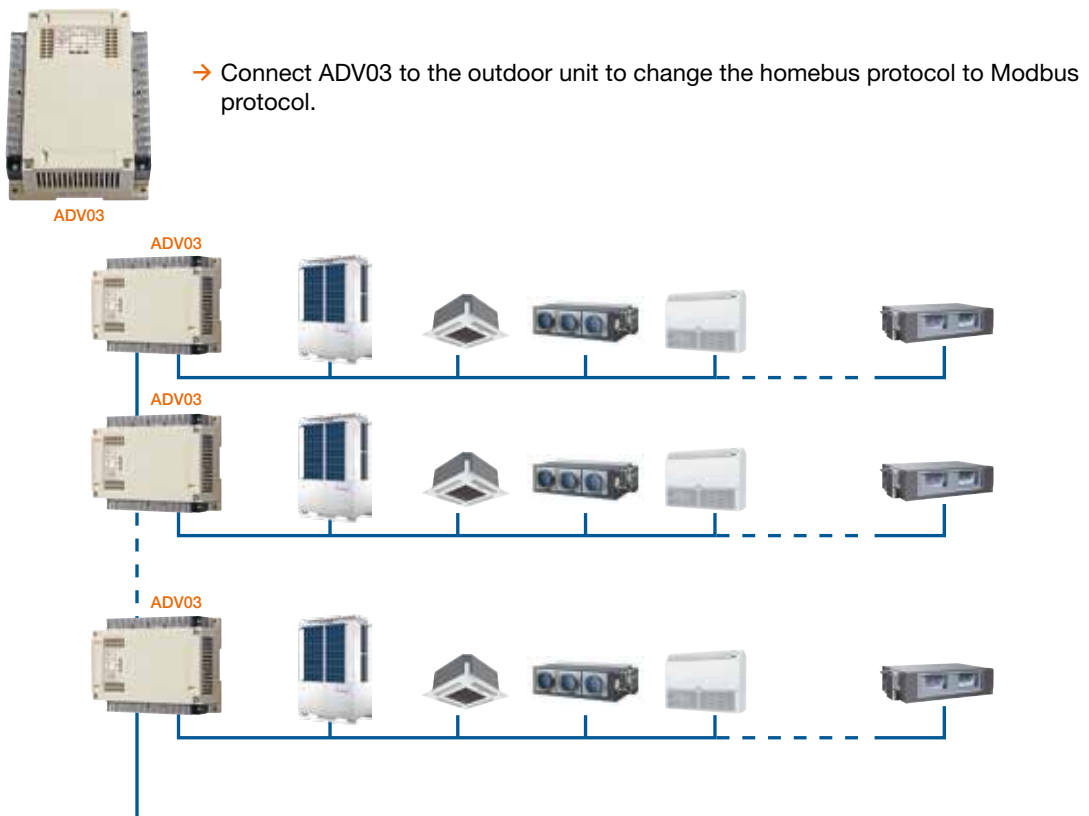

Part number ADV03: 7ACELH011

LONWORKS BMS CONTROL



- Every outdoor system adopts one ADV04 + ADV03
- In one system, total connected indoor units quantity is max. 32
- The ADV04 needs to be connected to an external 24V DC power supply

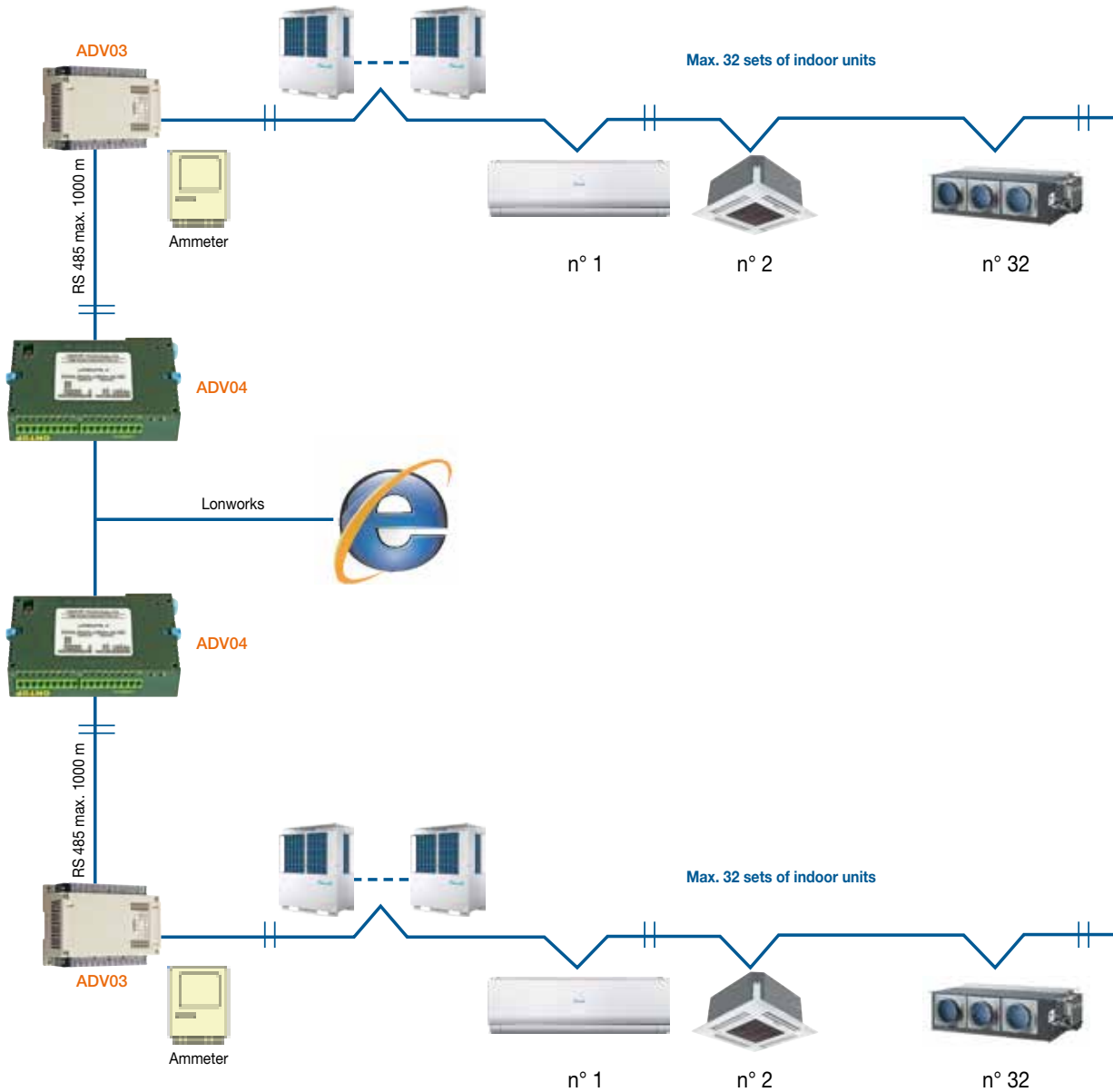













Part number ADV03: 7ACELH011
Part number ADV04: 7ACELH012

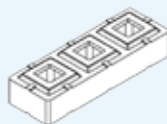
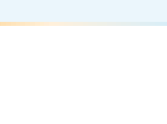



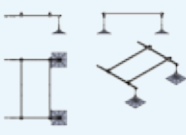

[NAME]	Photo	Part number	Model
CONTROLLERS	INFRARED CONTROLLER		7ACELH022 RCV02
	INFRARED CONTROLLER RECEIVER		7ACELH009 REC01
	SIMPLIFIED CONTROLLER		7ACELH008 RWV03
	WIRED STANDARD CONTROLLER	NEW 	7ACELH021 RWV05
	WIRED CONTROL WEEKLY TIMER	NEW 	7ACELH024 RWV07
	MINI CENTRAL CONTROLLER	NEW 	7ACELH025 RWV08
	CENTRAL CONTROLLER "TOUCH SCREEN"	NEW 	7ACELH023 RWV06
BMS SOLUTIONS & MAINTENANCE	CONNECTING BOARD		7ACELH004 ADV01
	INVERTER PROTOCOL ADAPTATER		7ACELH007 ADV02
	MODBUS & LONWORKS GATEWAY		7ACELH011 ADV03
	LONWORKS GATEWAY		7ACELH012 ADV04
	RS485&232 CONVERTER + SOFTWARE		7ACELH005 BMV01
	PROTOCOL BACNET IP/MSTP + PROTOCOL MODBUS RTU/TCP		7ACELH013 BMV03
	TEST TOOL FOR VRF 15 AND 18 KW		7ACELH020 -
	TUBING ACCESSORIES	GATHER PIPE KIT FOR 2 INDOOR UNITS	
GATHER PIPE KIT FOR 3 INDOOR UNITS			7ACFHH014 TBS30
			7ACFHH001 TAU335
			7ACFHH002 TAU506
MANIFOLD PIPE (GAS + LIQUID)			7ACFHH003 TAU730
			7ACFHH004 TAU1350
		7ACFHH015 TAU2040	

[FUNCTION]	[FOR WHAT UNITS?]	[OPTIONAL/COMMENTS]
Unit operating	All indoor units	Standard with high wall and console Optional with cassette and ducted
Realize infrared control for duct type	Ducted	-
Unit operating and group control (max. 16 indoor units)	All (except for console type)	-
Unit operating, group control (max. 16 indoor units) and "I Feel" function.	High wall, ducted cassette, floor ceiling	Standard with cassette, ducted and floor ceiling
Single unit control, group control, max. 16 units, weekly timer, clock, mode cooling/heating/auto/ airflow/dehumidification, temperature, fan speed, fan direction	High wall, cassette, ducted, floor ceiling	-
32 indoor units max., individual control, group control, central control, weekly timer, error display.	Mini FlowLogic II FlowLogic III	Mandatory with ADV01
Central control, single unit control, group control, max. 256 units, weekly timer, clock, mode cooling/heating/auto/airflow/dehumidification, temperature, fan speed, fan direction	Mini FlowLogic II FlowLogic III	Mandatory with ADV01
Connecting RWV06 and outdoor units	Mini FlowLogic II FlowLogic III	Mandatory with RWV06
Protocol adapter and data storage	Mini FlowLogic II FlowLogic III	Mandatory with BMV01 and BMV03
Connect the outdoor unit to change the homebus protocol to Modbus protocol.	Mini FlowLogic II FlowLogic III	-
Every outdoor system adopts one ADV04 + ADV03. In one system, total connected indoor units quantity is max. 32. The ADV04 needs to be connected to an external 24V DC power supply	Mini FlowLogic II FlowLogic III	Mandatory with ADV03
BMS control (air conditioner edition) In one system, total connected indoor units quantity is max. 40.	Mini FlowLogic II FlowLogic III	Mandatory with ADV02
BMS control (BACnet protocol edition)	Mini FlowLogic II FlowLogic III	Mandatory with ADV02
Useful during process of installation or maintenance, the whole system's operating parameters can be tested.	YCV 150 YCV 180	-
Refrigerant gathering	FlowLogic III	For 2 outdoor units
Refrigerant gathering	FlowLogic III	For 3 outdoor units
Refrigerant distribution	Mini FlowLogic II FlowLogic III	33.5 kW > Total indoor units power
Refrigerant distribution	Mini FlowLogic II FlowLogic III	33.5 kW ≤ Total indoor units power < 50.6 kW
Refrigerant distribution	Mini FlowLogic II FlowLogic III	50.6kW ≤ Total indoor units power < 73 kW
Refrigerant distribution	Mini FlowLogic II FlowLogic III	73 kW ≤ Total indoor units power < 135 kW
Refrigerant distribution	Mini FlowLogic II FlowLogic III	135 kW ≤ Total indoor units power

Installation accessories

[NAME]		Photo	Part number	[FUNCTION]		
COPPER	INSULATED COPPER M1		1/4"-3/8" - 10ml	7ACFH0810	Refrigerant tubing to connect outdoor unit with indoor unit (monosplit and multisplit).	
			1/4"-1/2" - 10ml	7ACFH0811		
			3/8"-5/8" - 10ml	7ACFH0812		
			1/4"-3/8" - 7ml	7ACFH0813		
			1/4"-1/2" - 7ml	7ACFH0814		
			3/8"-5/8" - 7ml	7ACFH0815		
OUTDOOR UNIT SUPPORT	WALL BRACKET	Max. charge 160 kg Horiz. 560 mm Vert. 365 mm Barre 800 mm		7ACTL0506	Support to install an outdoor unit on facade (monosplit and multisplit).	
	ANTI-CORROSION WALL BRACKET	Max. charge 160 kg Horiz. 460 mm Vert. 410 mm Barre 790 mm		7ACTL0507	Support to install an outdoor unit on facade (monosplit and multisplit).	
	4 ANTI-VIBRATILE PADS (KIT)			7ACTL0508	Ideal to limit noise and vibrations (good neighborhood).	
	FLOOR SUPPORT RUBBER RECYCLED (PAIR)	Longueur 600 mm			7ACTL0509	Necessary for a professional installation. High quality: using rubber material.
		Longueur 1000 mm			7ACTL0510	
	FLOOR SUPPORT (PAIR)	450x100 mm			7ACTL0513	Necessary for a professional installation. Good quality price ratio: using PVC material.
	RUBBER SUPPORT (PAIR+GLUE)	G600			7ACTL0511	Raise to avoid frosting. Compatible with floor support made of recycled rubber (same sizes).
G1000				7ACTL0512		

[NAME]		Photo	Part number	[FUNCTION]	
FRAME VRF	FRAME VRF 4 FEET (2 UNITS)	Max. charge 500 kg 1000x1200 mm		7ACTL0514	Available for all VRF outdoor unit range.
	FRAME VRF 6 FEET (4 UNITS)	Max. charge 1040 kg 2000x1200 mm		7ACTL0515	Available for all VRF outdoor unit range.
	EXTENSION VRF 2 FEET	Max. charge 500 kg 1000x1200 mm		7ACTL0516	Available for all VRF outdoor unit range.
CLEANING	FLUSH KIT FOR TUBING DIVERSIFLUSH			7ACFH0816	Cleans your old refrigerant circuit (to replace old R22 installation).
	SOLVENT CONTAINER DIVERSIFLUSH (REFILL)			7ACFH0817	
WATER PUMP	WATER PUMP MINI FLOWATCH MF2			7ACTL0517	Evacuate condensates from indoor units (high wall, ducted, floor ceiling units).
	WATER PUMP FLOWATCHDESIGN			7ACTL0518	Evacuate condensates from indoor units (high wall, ducted, floor ceiling units).

		INFRARED CONTROL			WIRED REMOTE			
		RC08C NEW	RC08W	RCV02	RCW2	RCW6	RCW8	RCW16
Part number:		7ACEL1740	7ACEL1741	7ACELH022	7ACEL1212	7ACEL1704	7ACEL1706	7ACEL1707
[RANGE]								
Function	Weekly timer				●	●		
	Group control				●	●		●
	Centralized control				●			
	ON/OFF Timer	●	●	●	●	●	●	●
HIGH WALL	HRD	●						
	HND	●					●	
	HKD	●					●	
DUCTED	DLF		●		●			
	DLSE		●		●			
	DID	●				●	●	●
	DED							
CASSETTE	CCD	●				●	●	●
FLOOR-CEILING	XBD	●					●	●
	FCD	●				●	●	●
	FWDB					●		●
MONOBLOC	MAF	●						
	WFD							
	SBF	●						
LIGHT COMMERCIAL	HAN				●			
VRF	HBV			●				
	CBV			●				
	CCV			●				
	FAV			●				
	DAV			●				
	DBV			●				
	DCV			●				
	EAV			●				

Airwell Sensibo



Airwell Sensibo is a controlling system that manages remote operation of your air conditioning, whatever the brand of your air conditioner, technology (Fixed speed or Inverter) or gas used (R22, R407C, R410A...). The system is easy to install and operate.

- Works on all type of A/C which operates with infrared remote controller.
- Easy installation with no wires to the unit.
- Can be transferred from one A/C to another.
- "Plug & Play" system composed by a hub and up to 10 pods to control your air conditioning.

CONFIGURATION

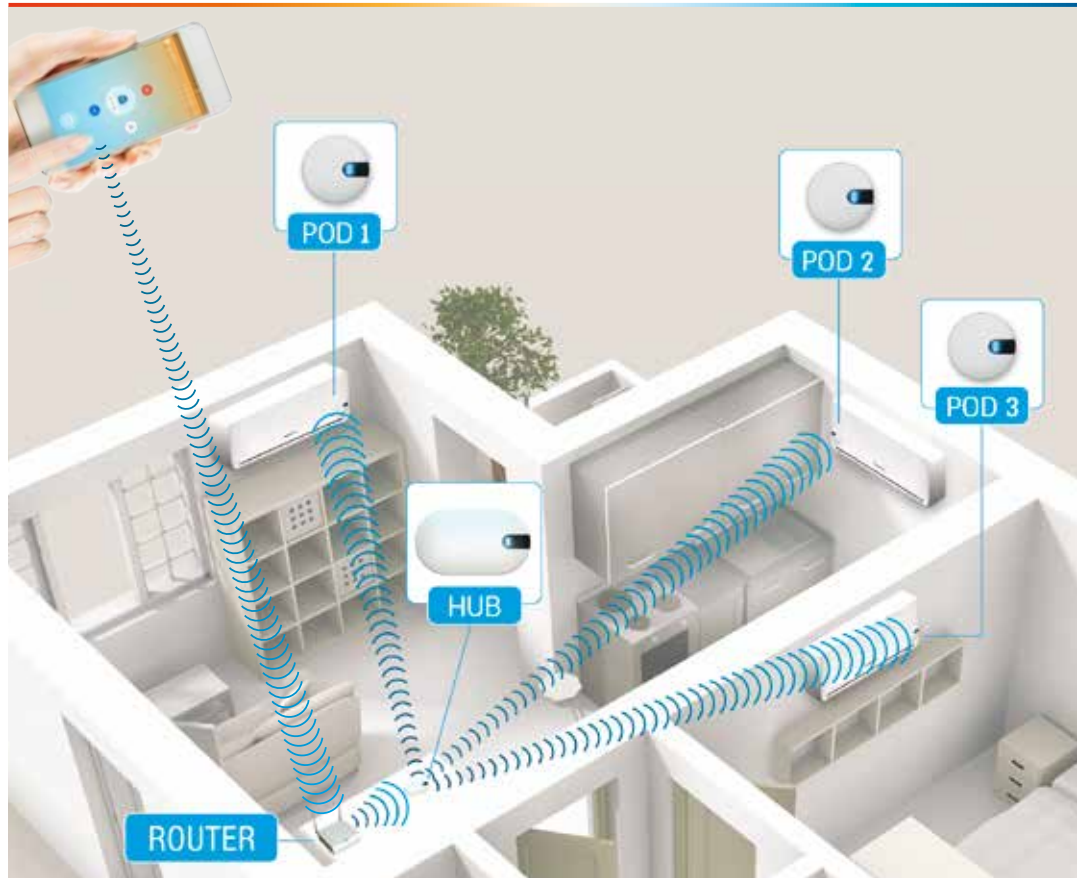

MAIN FEATURES



Cools or heats your home before you arrive



Saves energy and reduces your electricity bill



Weekly timer to save energy



Lets you control the A/C from anywhere



Optimizes temperature and humidity levels

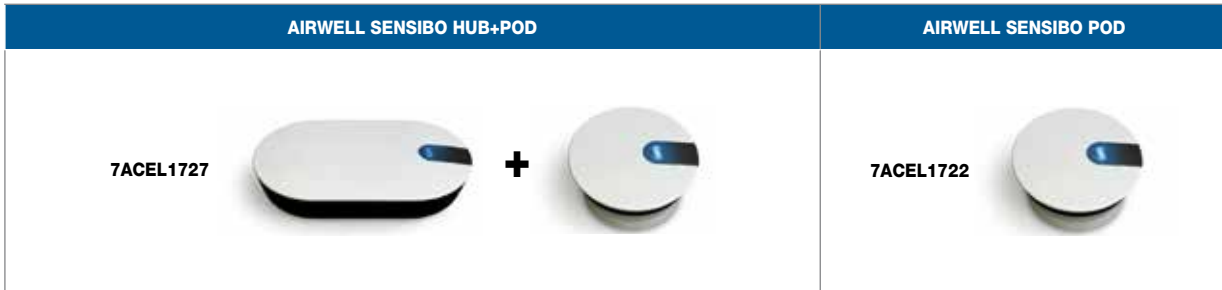

OUR WIFI SOLUTIONS

FUNCTIONS	OPTIONAL	AIRWELL SENSIBO SOLUTION
	On-off, Operation mode, Fan speed, Temperature set-up, Timer 	On-off, Operation mode, Temperature set-up, Fan speed, Timer, Weekly timer 
High wall HRD	●	●
High wall HND	●	●
High wall HKD	●	●
Ducted DLF		●
Ducted DLSE		●
Ducted DID		●
Cassette CCD		●
Console XBD		●
Floor Ceiling FCD		●
Portable MAF		●
Window WFD		●
Floor standing SBF		●



MEASURE UNITS CONVERSION

Length			
1 inch (in)	0.0254 m		
1 foot (ft)	12 inches	0.3048 m	
1 yard (yd)	3 feet	0.9143 m	
1 mile (mi)	1.760 yards	1609 m	
1 nautical mile (nmi)	1852 m		
1 meter (m)	39.37 inches	3.28084 feet	1.09361 yard

mm	Inches
6.35	1/4
9.52	3/8
12.70	1/2
15.88	5/8
19.05	3/4
22.22	7/8
25.40	1
28.58	1"1/8
31.75	1"1/4
38.10	1"1/2

Volume	
1 cubic inch (cu in)	16.387064 cm ³
1 cubic foot (cu ft)	0.028317 m ³ /28.31685 dm ³
1 cubic yard (cu yd)	0.76455 m ³
1 pint	0.568 l
1 gallon-imp	4.546 l
1 gallon (US gal)	3.78541 l or dm ³
1 cubic meter (m ³)	35.31467 cu ft
1 cubic decimeter (dm ³)	0.26428 gal
1 liter (l)	1 dm ³

HP (horse power) *	Btu	kW
1	9000	2.637
1.5	12000	3.516
2	18000	5.274
2.5	24000	7.032
3	30000	8.79
5	45000	13.185

Mass volume	
1 cu.ft/lb	62.43 dm ³ /kg
1 US gallon/pound	8.3 dm ³ /kg

Density	
1 pound/cu.ft	0.016 kg/dm ³

Mass		
1 ounce (oz)	28.349 g	
1 pound (lb)	16 oz	0.4536 kg
1 quintal U.S	100 lbs	
1 centweight	112 lbs	
1 short ton (US)	2000 lbs	907.18 kg
1 long ton (GB)	2240 lbs	1016.04 kg
1 quintal (q)	100 kg	
1 tonne (t)	1000 kg	

Area		
1 square inch (in ²)	6.4516 cm ²	
1 square foot (ft ²)	0.0929 m ²	
1 square yard (yd ²)	0.8361 m ²	
1 square meter (m ²)	1550 in ²	10.76391 ft ²

Energy - Heat quantity		
1 cal	4.18 joules	
1 Btu	0.252 kcal	1055 joules
1 Btu/lb.°F	1 kcal/kg °C	
1 kcal	1 millithermie	
1 fg/h	-1 kcal/h	
1 kcal/h	1.163 W	
1 Btu/h	0.293 W	
1 ton (US)	3024 kcal/h	3512 W
1 ton (GB)	3340 kcal/h	3878 W
1 watt (thermic)	0.86 kcal/h	

° Fahrenheit = °C x 9/5 + 32
 ° Celsius = (°F-32) x 5/9
 ° Celsius = T (Kelvin) - 273.15
 * Indicative values

Rated powers of our products are given for air conditions as following:
 Cooling mode: 35°C out/27°C in (dry bulb)
 Heating mode: +7°C out/20°C in (dry bulb)

SIZING THE AIR CONDITIONING

STEP 1: EVALUATING THE NEEDS

In order to size properly your air conditioning installation, it's important to calculate the thermal needs of your habitation to calculate the power needed for your setup.

■ SIZING THE COOLING NEEDS BY OCCUPANCY RATIO

We use the following ratio to calculate the cooling power needed:

$$90 \text{ W/m}^2 + 100 \text{ W/Occupant}$$

The calculation is to be done room by room.

■ SIZING THE HEATING NEEDS BY THE G METHOD

The « G » is the volume loss coefficient of the building, matching the sum of the thermal loss through walls, windows, roofs... It's expressed in $\text{W/m}^3/\text{°C}$. This coefficient is related to the building isolation.

$$\text{Heat power (W)} = G \times V \times \Delta T$$

G = global loss coefficient ($\text{W/m}^3 \times \text{°C}$):

- 0,65 W/°C m^3 new construction
- 0,75 W/°C m^3 construction after 2000
- 0,9 W/°C m^3 constructions after 1980
- 1,2 W/°C m^3 constructions moderately insulated
- 1,8 W/°C m^3 constructions poorly insulated

V = building volume (m^3)

ΔT = Temperature difference between interior (19 or 20°C), and average exterior temperature in the region where is based the project.

STEP 2: EXTERIOR UNITS SELECTION

Dispatch the cooling and heating needs calculated before (cf. step 1).

Calculate the global needs by zone, in order to determine outdoor unit capacity.

STEP 2: EXTERIOR UNIT SELECTION				
Zone	Rooms	Cooling needed (kW)	Heating needed (kW)	Maximum number of interior units desired
Zone 1	Room n°1			
	Room n°2			
	Room n°3			
	Room n°4			
	Room n°5			
	Room n°6			
	TOTAL			
Zone 2	Room n°1			
	Room n°2			
	Room n°3			
	Room n°4			
	Room n°5			
	Room n°6			
	TOTAL			
Zone 3	Room n°1			
	Room n°2			
	Room n°3			
	Room n°4			
	Room n°5			
	Room n°6			
	TOTAL			

TECHNOLOGY



FLEXY MATCH

Indoor units are compatible with split or multisplit installation.



DC INVERTER

Compressor with high efficiency DC engine.



1 W STANDBY POWER

Maximum reduction of energy waste once the unit is in standby mode.



LOW VOLTAGE STARTUP

Designed to start the unit even if power is not stable.



LOW TEMPERATURE STARTUP

Unit powered on even when external temperature goes down to -15°C.



R410A FLUID

Refrigerant fluid R410A.



R32 FLUID

Refrigerant fluid R32.



VAV COMPATIBILITY

Automatic air volume Automatic control of air volume and system based on difference between real ambient temperature and temperature setting.



ELECTRONIC EXPANSION VALVE

Precise control of coolant flow, optimization of performance and compressor protection.



REFRIGERANT LEAKAGE DETECT

Indicates a refrigerant leakage on indoor unit and stops the system for compressor protection.

AIR QUALITY/CLEAN



STERIONIZER

Generates sterionizer ions producing electrochemical reaction destroying bacteria, viruses and allergenic particles. Creates and ensure provisioning of natural and high quality air in living environment.



NANO PHOTOCATALYTIC FILTER

Oxidizes and degrades organic contaminants. It can eliminate up to 99.9% of bacteria and can efficiently block dusts.



AIR FILTER

Eliminates fine particles and purifies the air.



AUTO CLEAN/DRY

Prevents development of bacteria and moistures keeping the heat exchanger dry after a cooling operation.



FRESH AIR

Cools the room bringing fresh air from outside.



FILTER CLEAN INDICATION

Control led asking for verification and cleaning of the air filter.

COMFORT FUNCTIONS



I FEEL

Precise control of temperature all around the chosen zone via a remote temperature sensor.



MOTORIZED 4D AIRFLOW

Heating and cooling operations are optimized with an automatic horizontal and vertical oscillation.



MULTIFLOW 360°

Air distribution system with great comfort on 360° and 4 directions with motorized opening control.



SLEEP MODE

Temperature in the room adjustment based on sleeping habits.



SUPER QUIET

Top design for the lowest sound level.

FUNCTION



DIGITAL DISPLAY

Digital display of error codes or temperature settings on the indoor unit.



TURBO MODE

Improved net power and fast reaction while reaching the temperature setting for the room.



PROGRAMMABLE TIMER

Adjustable timer for power on and power off.



SELF DIAGNOSTIC

Unit failure indication through a blinking led on the unit display.



LOW BATTERY INDICATION

Indicates a need for battery replacement on the remote.



AUTO RESTART (MEMORY)

Restarts automatically the unit in the last used mode when power is back.



REMOTE CONTROL LOCK

Locks the remote functions to avoid unexpected actions.



ADVANCED DEFROST

Reduces the operation to a minimum, without supplying power during defrost in heating mode.



AUXILIARY HEATER

Relaunches the heating capacity when the systems runs at a very low ambient temperature.



INTEGRATED WATER PUMP

Eliminates condensate for a simple and smooth use.



LEFT/RIGHT DRAIN CONNECTION

Easy installation connecting condensate tubing either on left or right side.



FREQUENCY CONTROL INCLUDING AIRFLOW

Adjusts the engine speed depending on the flow rate to optimize the air volume.



TWIN APPLICATION

An outdoor unit is connected to two similar indoor units.



OUTDOOR BASE HEATER

Prevents ice production.



CRANKCASE HEATER

Protects compressor oil from freezing.

CONTROL OPTION CONNECTIVITY



ALARM OUTPUT

Remote transmission of dysfunction errors.



UNIT ON OUTPUT

Displays on the remote the power on or power off status of the unit.



DRY CONTACT ON/OFF

Connection to an external presence detection with adjusted control of the unit and power saving when the room is empty.



BMS COMPATIBLE

Connection to the BMS system via PCB adapter.



SERVICE MONITOR TOOL

PC interface for monitoring and adjusting the settings of the unit.



WIFI

Air conditioner controlled via mobile phone, tablet or computer through a wireless router and internet, thanks to AIR NET application.



WIFI

Air conditioner controlled via mobile phone, tablet or computer through a wireless router and internet, thanks to AIRWELL SENSIBO application.

OUTDOOR UNIT OPTION



POWER CONSUMPTION CONTROL

Energy consumption control reducing the maximum power on the unit.



WIRED REMOTE CONTROL DIAGNOSTIC

Diagnostic mode through the remote of the indoor unit.



OUTDOOR UNIT DIGITAL DIAGNOSTIC

Displays a digital error code for an easier maintenance.



OUTDOOR UNIT NIGHT MODE DRY CONTACT

Engine speed limitation and noise level reduction of the outdoor unit.



OUTDOOR UNIT STAND-BY

Power on or power off of the outdoor unit from the remote.



OUTDOOR UNIT ALARM OUTPUT

Transmission of an air output default alarm to a remote system.



FULL LENGTH REFRIGERANT PRECHARGE

No additional fee, easy and affordable installation.



TECHNICIAN TEST MODE

Special mode optimizing the duration of intervention of the technician.



LOW AMBIENT COOLING

Operating on cooling mode even with low external temperature with advanced control system.



LOW AMBIENT HEATING

Specific conception of the unit allows operating on heating mode even with low external temperature.

Airwell

AIR CONDITIONING & HEATING

Our Aftersales Service

Export

Tel. ■ +33 (0)1 76 21 82 95

SPARE PARTS ORDERS:
e-mail ■ sp@airwell-res.com

TECHNICAL SUPPORT:
e-mail ■ technical-spfr@airwell-res.com

Airwell
Residential

3, AVENUE DU CENTRE, LES QUADRANTS, BÂT. A - 78280 GUYANCOURT, FRANCE
TEL.: +33 (0)1 76 21 82 00 - FAX: +33 (0)1 76 21 82 01 - www.airwell-residential.com