

Unitary Full DC Inverter Mini Chiller

DC INVETER
R410A



ENGLISH

Unitary Full DC Inverter Mini Chiller
05 -07 kW

Thank you very much for purchasing our air conditioner,
please read this installation&owner's manual carefully before using your air conditioner.



INDEX

U	I	A	General warnings	2	I	A	Hydraulic data	15	
U	I	A	Fundamental safety rules	2	I	A	Refrigerant circuit	15	
	I	A	Description of standard unit	3		A	Checking and starting up the unit	16	
	I		Dimensioned drawings	4	U	I	A	Activating and deactivating the unit	16
	I		Installation	4	I	A	Operating characteristics	20	
	I	A	Hydraulic connections	4		A	Shutting down for long periods	21	
	I	A	Electrical connections	6		A	Routine maintenance	21	
	I	A	General technical data	10		A	Extraordinary maintenance	21	
		A	Cooling performance	12		A	Disposal	22	
		A	Heating performance	13					
	I	A	Recommended operating area	14					

The following symbols are used in this publication and inside the unit:



User



Important



Danger moving blades



Installer



Prohibition



Danger high temperatures



Assistance



Danger voltage

This appliance can be used by children aged from 8 years and above and persons with reduced physical, sensory or mental capabilities or lack of experience and knowledge if they have been given supervision or instruction concerning use of the appliance in a safe way and understand the hazards involved. Children shall not play with the appliance. Cleaning and user maintenance shall not be made by children without supervision.

 These units have been designed to chill and/or heat water and must be used in applications compatible with their performance characteristics; these appliances are designed for residential or similar applications.

Incorrect installation, regulation and maintenance or improper use absolve the manufacturer from all liability, whether contractual or otherwise, for damage to people, animals or things. Only those applications specifically indicated in this list are permitted.

Read this manual carefully. All work must be carried out by qualified personnel in conformity with legislation in force in the country concerned.

The guarantee is invalidated if the above instructions are not respected and if the unit is started up for the first time without the presence of personnel authorised by the Company (where specified in the supply contract) who should draw up a "start-up" report.

The documentation supplied with the unit must be consigned to the owner who should keep it carefully for future consultation in the event of maintenance of service.

All repair or maintenance work must be carried out by the Company's Technical Service or qualified personnel following the instructions in this manual. The air-conditioner must under no circumstances be modified or tampered with as this may create situations of risk. Failure to observe this condition absolves the manufacturer of all liability for resulting damage.

Stationary appliances not fitted with means for disconnection from the supply mains having a contact separation in all poles that provide full disconnection under overvoltage category III, the instructions state that means for disconnection must be incorporated in the fixed wiring in accordance with the wiring rules.

FUNDAMENTAL SAFETY RULES

U I A

When operating equipment involving the use of electricity and water, a number of fundamental safety rules must be observed, namely:

 This appliance is not intended for use by persons (including children) with reduced physical, sensory or mental capabilities, or lack of experience and knowledge, unless they have been given supervision or instruction concerning use of the appliance by a person responsible for their safety.

Do not touch the unit with bare feet or with wet or damp parts of the body

Do not carry out cleaning operations without first disconnecting the system from the electricity supply.

Do not modify safety or regulation devices without authorisation and instructions from the manufacturer.

Do not pull, detach or twist the electrical cables coming from the unit, even when disconnected from the mains electricity supply.

Do not open doors or panels providing access to the internal parts of the unit without first ensuring that the mains switch is in the off position.

Do not introduce pointed objects through the air intake and outlet grills.

Do not dispose of, abandon or leave within reach of children packaging materials (cardboard, staples, plastic bags, etc.) as they may represent a hazard.

 The chiller appliances are supplied without the main switch. The power supply to the unit must be disconnected using a suitable main switch that must be supplied and installed by the installer.

 Respect safety distances between the unit and other equipment or structures. Guarantee adequate space for access to the unit for maintenance and/or service operations;

Power supply: the cross section of the electrical cables must be adequate for the power of the unit and the power supply voltage must correspond with the value indicated on the respective units. All units must be earthed in conformity with legislation in force in the country concerned.

 Hydraulic connections should be carried out as indicated in the instructions to guarantee correct operation of the unit. Empty the water circuit or add glycol if the unit is not used during the winter. Handle the unit with the utmost care to avoid damage.

These air cooled reverse-cycle chillers with axial-flow fans operate with refrigerant fluid and are suitable for outdoor installation.

They are factory tested and on site installation is limited to water and electrical connections.

STRUCTURE

Panels and base are made from galvanised steel plate painted with epoxy powder to ensure total resistance to atmospheric agents. Condensate collection pan as standard.

COMPRESSORS

Hermetic DC inverter compressor with crankcase heater and thermal cut-out .

EVAPORATOR

AISI 316 stainless steel plate type evaporator complete with electric heater and water flow switch.

Casing lined with anti-condensate closed cell neoprene cladding.

PUMPS

The units feature a pump with the moving parts in contact with the water made from corrosion resistant materials, extra wear ring on the impeller, built-in capacitor for high starting torque and automatic venting of impeller chamber.

PUMP ASSEMBLY

Pump assembly with expansion tank, safety valve, auto-water replenishing assembly, pressure gauge and pump.

CONDENSING COILS

Made from copper tubes and high surface area aluminium fins. Condensing coil protection grills as standard.

FANS

Axial-flow fans. DC motor with built-in thermal cut-out. Housed in aerodynamic tubes with accident prevention grill.

Device for operation with low outside air temperatures: continuous fan rotation speed control via condensing temperatures transducer.

POWER AND CONTROL ELECTRICAL PANEL

Power and control electrical panel constructed in accordance with IEC 204-1/EN60335-2-40, complete with compressor contactor.

OPTIONAL ACCESSORIES

- Removable metal mesh filter.
- Remote keyboard kit.
- Additional pump.

The above accessories are optional. Consult the relative documentation for assembly instructions and technical data.

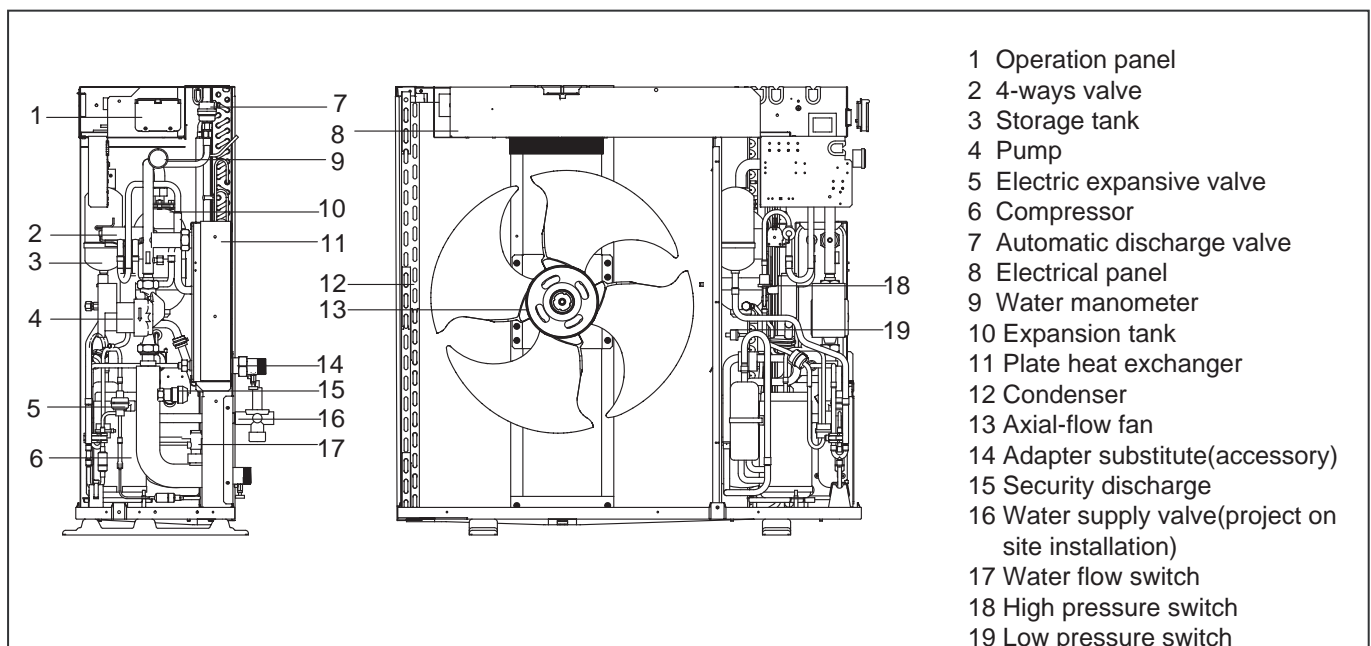

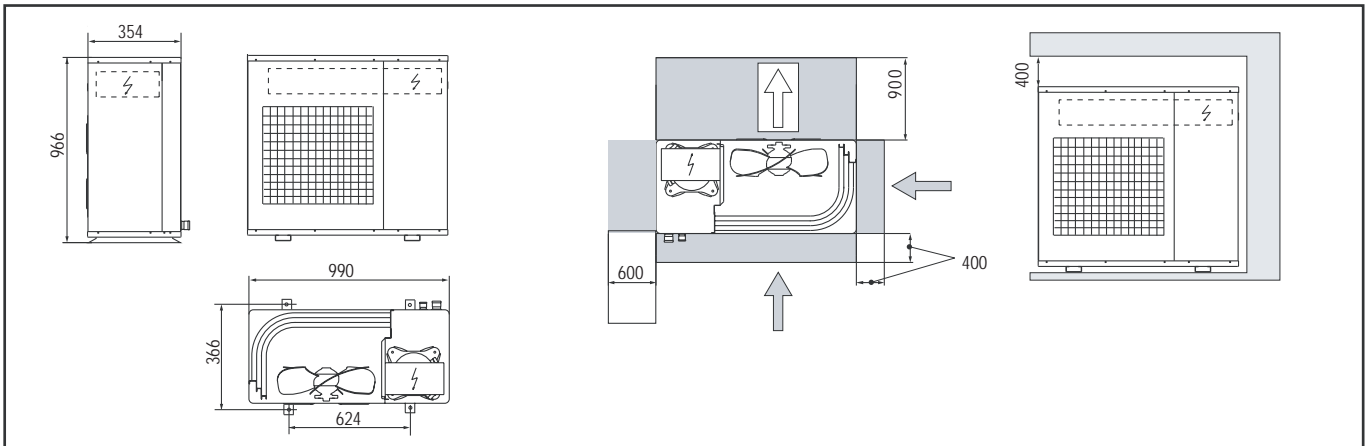

INSTALLATION

CHOICE OF INSTALLATION SITE

Before installing the unit, agree with the customer the site where it will be installed, taking the following points into consideration:

- check that the fixing points are adequate to support the weight of the unit;
- pay scrupulous respect to safety distances between the unit and other equipment or structures to ensure that air entering the unit and discharged by the fans is free to circulate.

POSITIONING

Before handling the unit, check the capacity of the lifting equipment used, respecting the instructions on the packaging.

To move the unit in the horizontal, make appropriate use of a lift truck or similar, bearing in mind the weight distribution of the unit. To lift the unit, insert tubes long enough to allow positioning of the lifting slings and safety pins in the feet on the unit.

To avoid the slings damaging the unit, place protection between the slings and the unit. Position the unit in the site indicated by the customer. Place either a layer of rubber (min. thickness 10 mm) or vibration damper feet (optional) between the base and support surface. Fix the unit, making sure it is level and that there is easy access to hydraulic and electrical components. If the site of installation is exposed to strong winds, fix the unit adequately to the support surface using tie rods if necessary. If a heat pump unit is being installed, make sure the condensate is drained using the drain hose supplied as standard. Prevent leaves, branches or snow from accumulating around the unit. These could reduce the efficiency of the unit.

HYDRAULIC CONNECTIONS

The choice and installation of components is the responsibility of the installer who should follow good working practice and current legislation. Before connecting the pipes, make sure they do not contain stones, sand, rust, dross or other foreign bodies which might damage the unit. Construction of a bypass is recommended to enable the pipes to be washed through without having to disconnect the unit (see drain valves). The connection piping should be supported in such a way as to avoid it weighing on the unit. It is recommended that the following devices are installed in the water circuit of the evaporator.

A hydraulic safety valve shall be mounted in water system, which should open constantly.

1. Two pressure gauges with a suitable scale (inlet and outlet).
2. Two vibration damper joints (inlet and outlet).
3. Two gate valves (normal in inlet and calibrating in outlet).
4. A flow switch (inlet) or a differential pressure switch (inlet-outlet).
5. Two thermometers (inlet and outlet).
6. An inlet filter as close as possible to the evaporator and positioned to allow easy access for routine maintenance.
7. An energy-saving water tank.
8. Additional pump.
9. The connecting line of flow switch, which mounted outside the unit, should be connected in series with the pressure-difference switch, which mounted inside the unit.

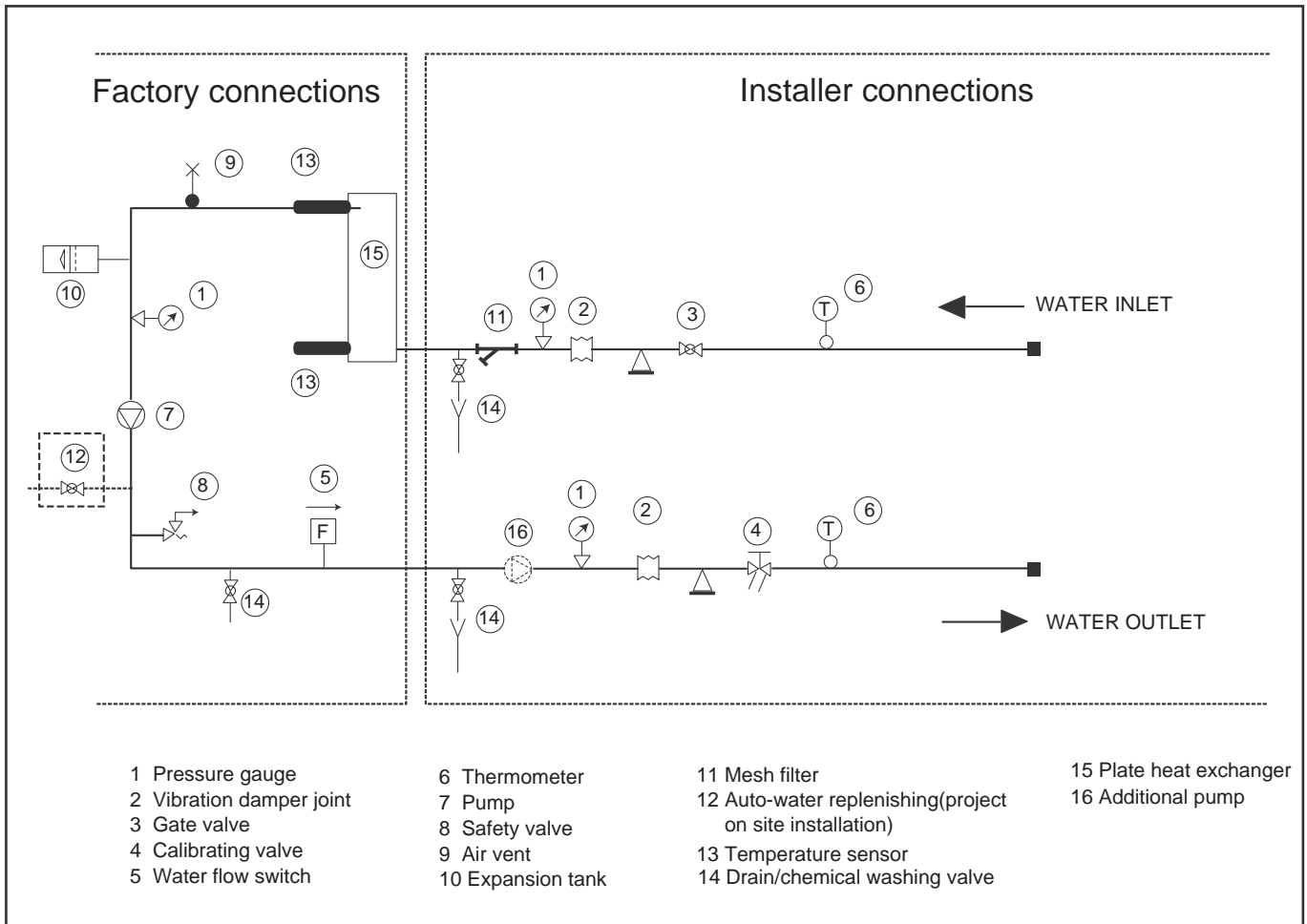

If the installation requires a useful head higher than that obtained by installing a pump assembly and storage tank, it is recommended that an additional pump is installed on the unit. Provided the additional pump installed inside of unit, the pump must be connected close to plate heat exchanger. Provided the pump installed outside of unit, the pump shall be connected at water pipe's outlet. The pump can be easily installed on the unit by removing the pump connection pipe (see page 3). Connect to terminal PL,PN on the electrical panel.

PH6-8	
Electrical conductivity	less than 200 mV/cm (25°C)
Chlorine ions	less than 50 ppm
Sulphuric acid ions	less than 50 ppm
Total iron	less than 0.3 ppm
Alkalinity M	less than 50 ppm
Total hardness	less than 50 ppm
Sulphur ions	none
Ammonia ions	none
Silicon ions	less than 30 ppm

⚠ The chillers must be provided with a filling/top-up system connected to the return line and a drain cock in the lowest part of the installation. Installations containing anti-freeze or covered by specific legislation must be fitted with hydraulic disconnectors.

⚠ The manufacturer is not liable for obstruction, breakage or noise resulting from the failure to install filters or vibration dampers. Particular types of water used for filling or topping up must be treated with appropriate treatment systems. For reference values, see the table.

FILLING THE INSTALLATION

- Before filling, check that the installation drain cock is closed.
- Open all installation and terminal air vents.
- Open the gate valves.
- Begin filling, slowly opening the water filling cock outside the unit.
- When water begins to leak out of the terminal air vent valves, close them and continue filling until the pressure gauge indicates a pressure of 1.5 bars.

EMPTYING THE INSTALLATION

- Before emptying,place the mains switch in the “off ” position
- Make sure the installation fill/top-up water cock is closed
- Open the drain cock outside the unit and all the installation and terminal air vent valves.

SIZE AND POSITION OF CONNECTIONS

Model	5kW	7kW
A (mm)	95	95
B (mm)	126	126
C (mm)	250	250
D (mm)	360	360
E (mm)	68	68
F (mm)	114	114
Water inlet/outlet (Ø)	R1	R1
Auto-water replenishing (Ø)	G1/2	G1/2
Security discharge (Ø)	G1/2	G1/2

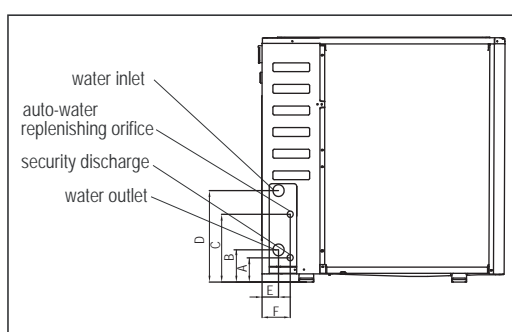

- ⚠ The installation must be filled to a pressure of between 1 and 2 bars. It is recommended that this operation be repeated after the unit has been operating for a number of hours. The pressure of the installation should be checked regularly and if it drops below 1 bar, the water content should be topped-up. Check the hydraulic tightness of joints.

- ⚠ An all-pole disconnection switch having a contact separation of at least 3mm in all poles should be connected in fixed wiring.
- ⚠ If the fluid in the circuit contains anti-freeze, it should not be allowed to drain freely as it is pollutant. It should be collected for possible reuse. When draining after heat pump operation, take care as the water may be hot (up to 50°).

ELECTRICAL CONNECTIONS

The unitary minichillers leave the factory already wired, and require the installation of an omnipolar thermal overload switch, a lockable mains disconnecting switch for the connection to the mains power supply, and the connection of the flow switch to the corresponding terminals. All the above operations must be carried out by qualified personnel in compliance with the legislation in force.

For all electrical work, refer to the electrical wiring diagrams in this manual. You are also recommended to check:

- that the characteristics of the mains electricity supply are adequate for the absorptions indicated in the electrical characteristics table below, also bearing in mind the possible use of other equipment at the same time.

- ⚠ Power to the unit must be turned on only after installation work (hydraulic and electrical) has been completed. All electrical connections must be carried out by qualified personnel in accordance with legislation in force in the country concerned. Respect instructions for connecting phase, neutral and earth conductors. The power line should be fitted upstream with a suitable device to protect against short-circuits and leakage to earth, isolating the installation from other equipment.

- ⚠ Voltage must be within a tolerance of $\pm 10\%$ of the rated power supply voltage for the unit (for three phase units, the unbalance between the phases must not exceed 3%). If these parameters are not respected, contact the electricity supply company. For electrical connections, use double insulation cable in conformity with current legislation in the country concerned

An omnipolar thermal overload switch and a lockable mains disconnecting switch, in compliance with the IEC-EN standards (contact opening of at least 3mm), with adequate switching and residual current protection capacity based on the electrical data table shown below, must be installed as near as possible to the appliance

- ⚠ The devices on the unit must be lockable. An efficient earth connection is obligatory. Failure to earth the appliance absolves the manufacturer of all liability for damage.
- ⊖ Do not use water pipes to earth the unit.

ELECTRICAL PANEL

The electrical panel is located inside the unit at the top of the technical compartment where the various components of the refrigerant circuit are also to be found.
To access the electrical panel, remove the front panel of the unit by undoing the screws.

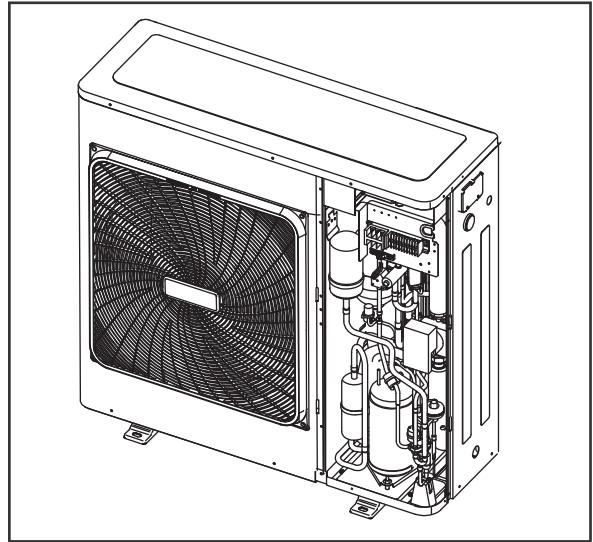

ELECTRICAL PANEL LAYOUT

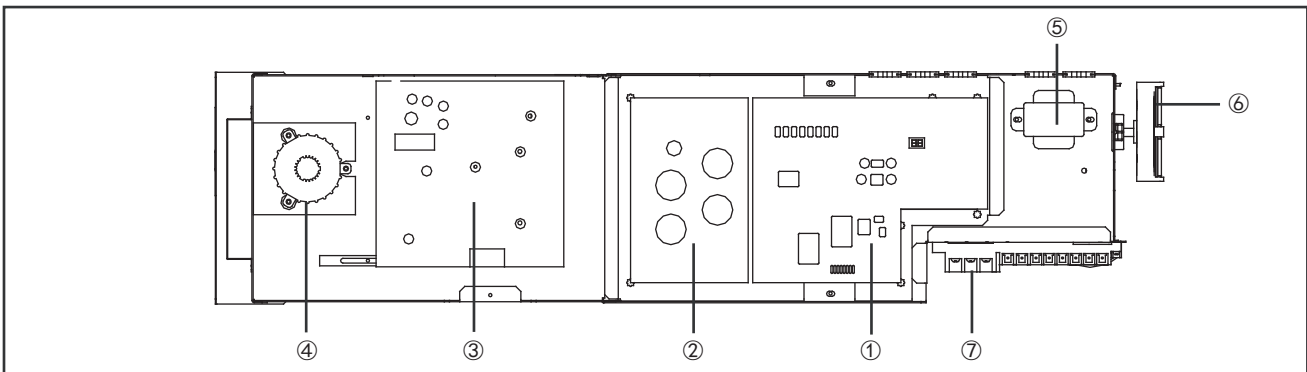

- | | | |
|-------------------------|-----------------|--------------------------------|
| ① Main control board | ④ FC inductance | ⑦ Customer connection terminal |
| ② DC filter board | ⑤ Transformer | |
| ③ IPM & PFC model board | ⑥ Display board | |

IPM & PFC model board

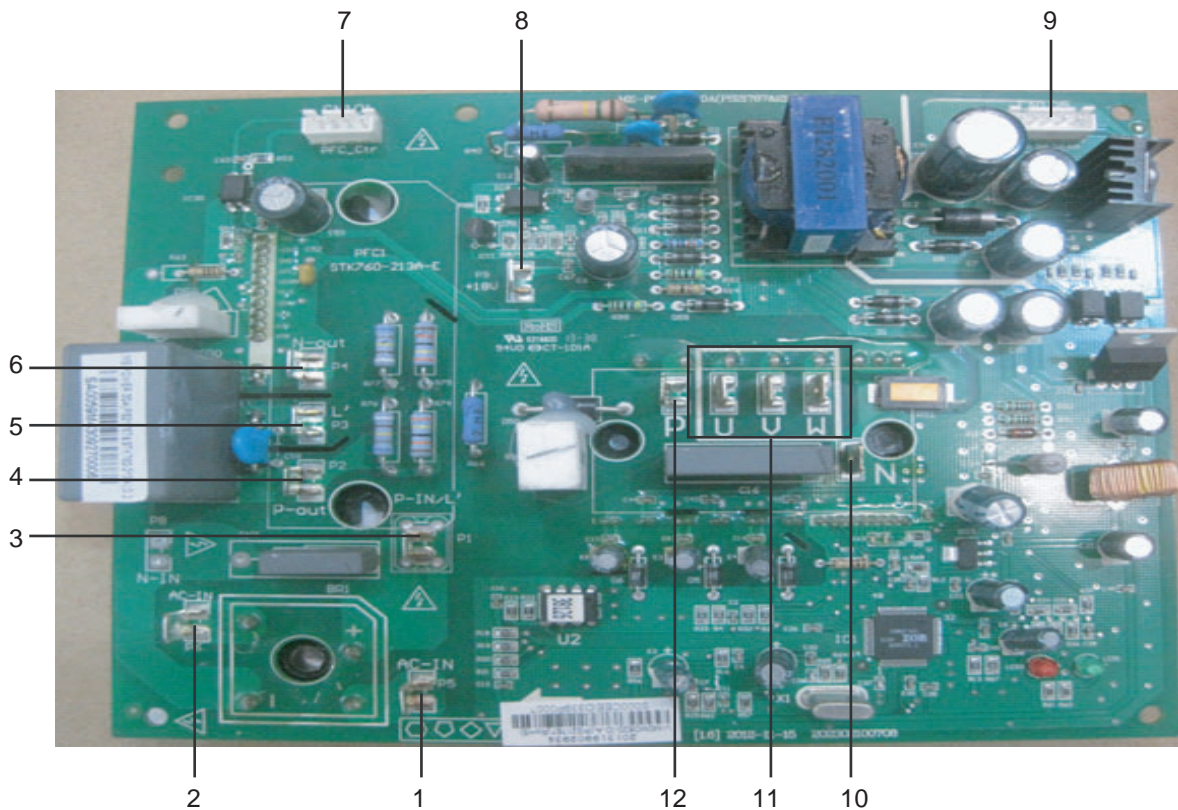

- | | | |
|----------------------------------|--------------------------|--------------------------------------|
| 1. Input rectifier bridge port 1 | 5. PFC inductance port 2 | 9. IPDU communication port |
| 2. Input rectifier bridge port 2 | 6. N-OUT | 10. IPM power port N |
| 3. PFC inductance port 1 | 7. PFC control port | 11. Compressor connection port U/V/W |
| 4. P-OUT | 8. +18V port | 12. IPM power port P |

Main control board

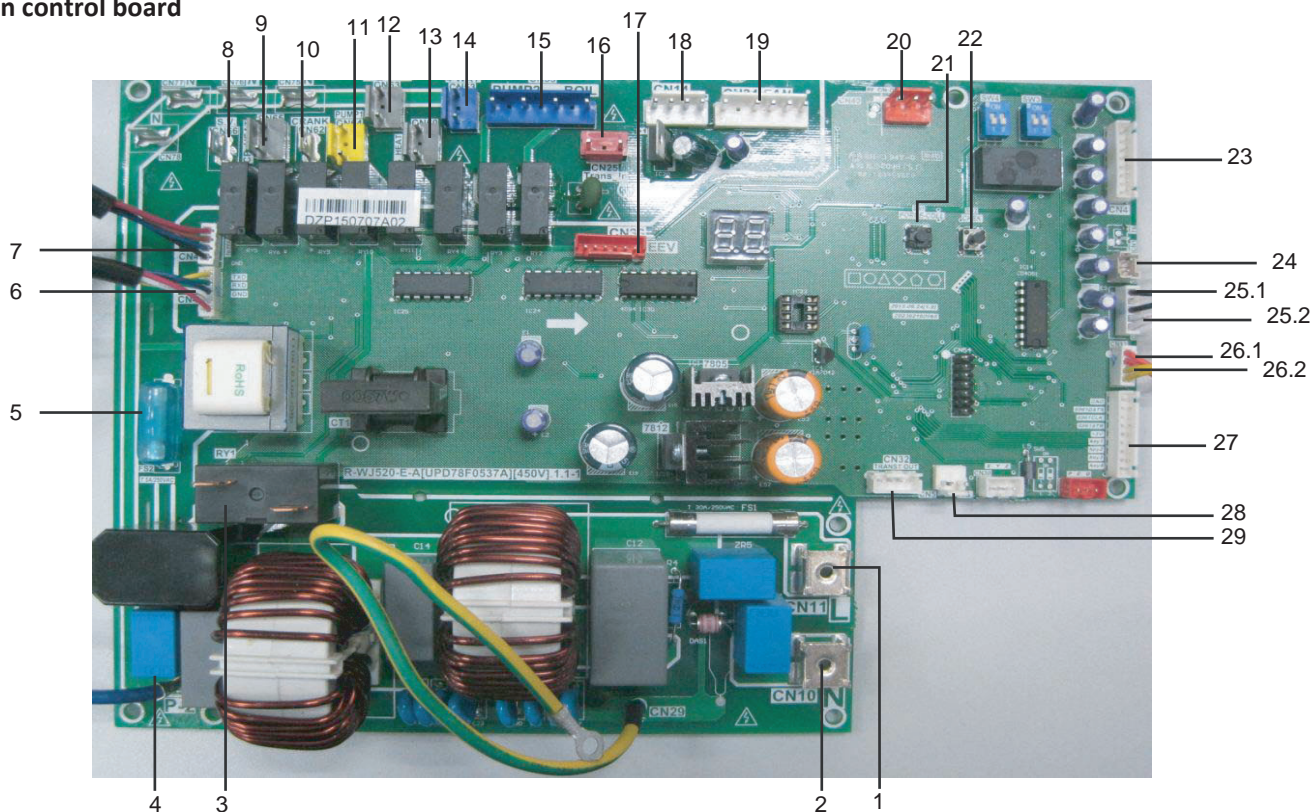

- | | |
|--|--|
| 1. Power L | 17. Electronic expansion valve |
| 2. Power N | 18. DC fan power supply port |
| 3. Preliminary charging relay (rectifier bridge input port 1) | 19. DC fan port |
| 4. Input rectifier bridge line (rectifier bridge input port 2) | 20. Remote control |
| 5. 5A fuse | 21. Forced cooling switch |
| 6. To IPDU | 22. Parameter checking switch* |
| 7. To PFC | 23. Tin/Tout/Tb1 temperature sensor |
| 8. Solenoid valve (Reserve) | 24. Discharge temperature sensor (Tp) |
| 9. Electric heating zone of plate heat exchanger | 25.1. Outlet of out door heat exchanger temperature sensor(T3) |
| 10. Electric heating zone of compressor | 25.2. Ambient temperature sensor(T4) |
| 11. Pump | 26.1. Low pressure switch |
| 12. Exhaust valve electric heating zone | 26.2. High pressure switch |
| 13. Electric heating zone of water flow switch | 27. operation and display panel port |
| 14. 4-way valve | 28. Water flow switch |
| 15. Additional pump/Boil (Reserve) | 29. Transformer output |
| 16. Transformer input | |

* Long press "Parameter checking switch" for 3s to enter into forced pump operation or turn off the pump.

DC filter board



- | |
|---------------------------------------|
| 1. IPM Power supply N |
| 2. IPM Power supply P |
| 3. PFC output power P |
| 4. PFC output power N |
| 5. DC 380V (DC fan power supply port) |

Customer connection terminal

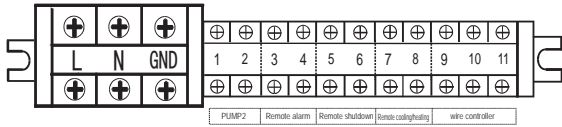

Electrical power connections

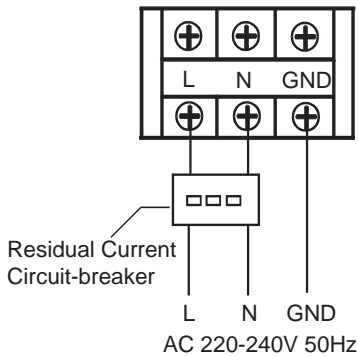

NOTE:

The outdoor units must be installed with an Residual Current Circuit-breaker near the power supply and must be effectively earthed.

Auxiliary function connections

■ Additional pump

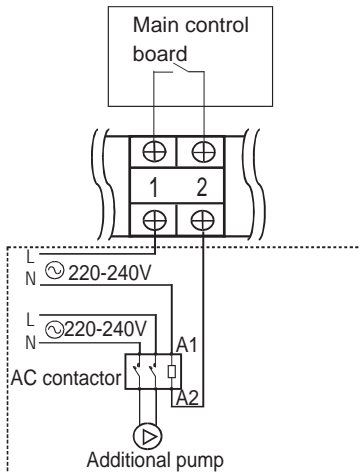

“PUMP2” terminal only provides passive switching signal. Additional water pump must be controlled by the AC contactor.

■ Remote alarm

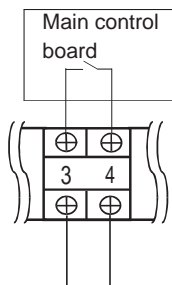

“Remote alarm” terminal only provides passive switching signal. Current passing through the terminal interface should be less than 1.5A, otherwise please use AC contactor to control load indirectly.

■ Remote shutdown

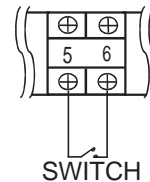

If switch is closed, the unit will be stopped forcibly. Under this circumstance, anti-frozen protection and other protection functions are still effective. If switch breaks, unit can run normally according to settings.

■ Remote cooling/heating

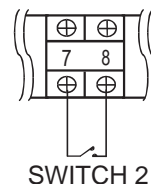

If switch2 is closed, the unit will shift to heating mode forcibly; If switch2 breaks the unit will shift to cooling mode forcibly.



Remote shutdown and Remote cooling/heating is an optional function. Choose this function by DIP switch SW4_1 on the PCB board. The factory default has no remote cooling/heating.

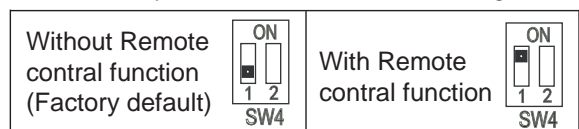

When the remote control and wire controller are used at the same time, the unit will carry out the last command of the arbitrary terminal. Remote shutdown has the highest priority. In the status of remote shutdown, other controllers can't start the unit.

■ Wire controller

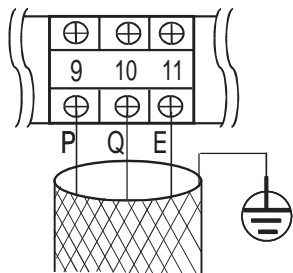

The wire controller is optional.

Please use 3-core shielded wire to connect the wire controller and the shielding layer must be grounded.

When connecting wire controller, host unit control panel is mainly used for display which can carry out parameter inquiry such as inquiry and checking, and can't be used to set mode and temperature.

The Specification of Power

TYPE		5 kW	7 kW
POWER	PHASE	1-PHASE	1-PHASE
	FREQUENCY AND VOLT	220-240V~, 50Hz	220-240V~, 50Hz
CIRCUIT BREAKER/FUSE (A)		25/20	30/25
POWER WIRING(mm ²)		3x2.5	3x2.5
GROUND WIRING(mm ²)		2.5	2.5

⚠ The power cord type designation is H07RN-F.

Connecting cable between indoor unit and outdoor unit shall be approved polychloroprene sheathed flexible cord, type designation H07RN-F or heavier cord.

The means for disconnection from a power supply shall be incorporated in the fixed wiring and have an air gap contact separation of at least 3mm in each active(phase) conductors.

GENERAL TECHNICAL DATA



Model HEAT PUMP	Type	5kW	7kW
Minimum water flow	m ³ /h	0.4	0.5
Rated water flow	m ³ /h	0.86	1.24
Residual head	kPa	21	35
Max. water pressure	bar	6.0	
Max. water-in pressure	bar	5.0	
Min. water-in pressure	bar	1.5	

- (1) condenser air in 35°C.evaporator water in/out 12/7°C.
- (2) Power also includes the pump power inside of it.
- (3) at 1m in open field fan side (sound pressure) .
- (4) the maximum and minimum operating pressure values refer to the activation of the pressure switches.
- * the two types of oil are equivalents

SINGLE-PHASE WIRING DIAGRAM(HEAT PUMP,5~7)

202090490086

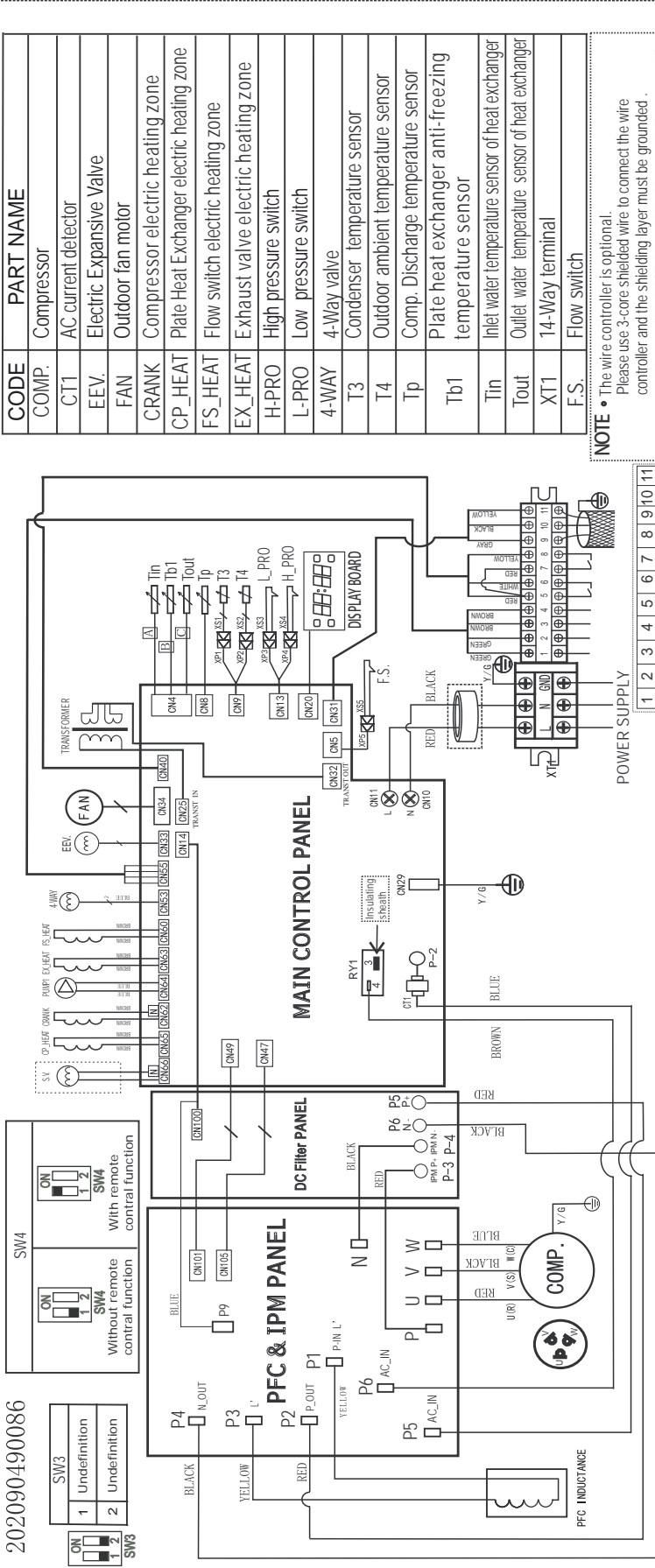

CODE	PART NAME
COMP.	Compressor
CT1	AC current detector
EEV.	Electric Expansive Valve
FAN	Outdoor fan motor
CRANK	Compressor electric heating zone
CP_HEAT	Plate Heat Exchanger electric heating zone
FS_HEAT	Flow switch electric heating zone
EX_HEAT	Exhaust valve electric heating zone
H-PRO	High pressure switch
L-PRO	Low pressure switch
4-WAY	4-Way valve
T3	Condenser temperature sensor
T4	Outdoor ambient temperature sensor
TP	Comp. Discharge temperature sensor
Tb1	Plate heat exchanger anti-freezing temperature sensor
Tin	Inlet water temperature sensor of heat exchanger
Tout	Outlet water temperature sensor of heat exchanger
XT1	14-Way terminal
F.S.	Flow switch

NOTE

- The wire controller is optional. Please use 3-core shielded wire to connect the wire controller and the shielding layer must be grounded.
- "PUMP2" and "REMOTE ALARM" wiring terminal points provide only the switch signal. The load should be controlled through the AC contactor.

Checking No.	Meanings
11	Tout temp. Value
12	Tb1 temp. Value
13	Tb2 temp. Value (Reserved)
14	T6 temp. Value (Reserved)
15	Outdoor units current
16	Power supply voltage AD value
17	EXV opening
18	Error 1
19	Error 2
20	Error 3
Temp. Sensor code	
Tin/Tout/Tb1/T3/T4	Property values
TP	B _{25/50} =4100K, R ₂₅ °C=10k Ω
	B _{25/50} =3950K, R ₅₀ °C=5k Ω

Checking No.	Meanings
0	The normal display
1	Frequency
2	Running mode 0-Shutdown, 1-The pump mode, 2-Cooling, 3-Heating, 4-Forced cooling.
3	Fan speed 0-Shutdown, 1-7-Fan speed
4	Total capacity requirements
5	The revised capacity requirements
6	Cooling/heating temp. set
7	T3 temp. Value
8	T4 temp. Value
9	TP temp. Value
10	Tin temp. Value

Display	Malfuction or Protection
CL	High inlet and outlet water temp. difference protection in cooling mode
CP	Plate Heat Exchanger anti-freezing protection
PL	Radiator high temperature protection
P1	High pressure protection
P2	Low pressure protection
P3	Outdoor units current protection
P4	Compressor discharge temp. Protection
P5	Condenser high temperature protection
P6	IPM mode protection
Pb	Outdoor units anti-freezing protection
PH	High temperature protection in heating mode
HH	Tin temperature sensor malfunction
dF	Defrosting
d8	Remote control

Display	Malfuction or Protection
E4	T3&T4 temperature sensor malfunction
E5	Voltage protection
E6	DC fan motor malfunction
E9	EEPROM malfunction
EA	5-minute error for heating mode fan in area A
Eb	Two times of E6 protection in 10 minutes
EC	Tout temperature sensor malfunction
C0	Tb1 temperature sensor malfunction
C1	Tb2 temperature sensor malfunction
C8	Flow switch malfunction
CH	Low water temperature protection in cooling mode
P8	Typhoon protection
H0	Communication malfunction between the main controlling chip and IPDU

Model: 5 kW

Chilled water outlet temp. (°C)	Ambient temp.(°C)																	
	21.00			25.00			30.00			35.00			40.00			46.00		
	Capacity kW	Power kW	COP W/W	Capacity kW	Power kW	COP W/W	Capacity kW	Power kW	COP W/W	Capacity kW	Power kW	COP W/W	Capacity kW	Power kW	COP W/W	Capacity kW	Power kW	COP W/W
5.00	5.60	1.37	4.10	5.27	1.41	3.75	4.97	1.45	3.43	4.70	1.50	3.14	4.40	1.57	2.80	4.05	1.65	2.46
6.00	5.79	1.39	4.17	5.44	1.43	3.81	5.13	1.47	3.48	4.85	1.52	3.19	4.54	1.59	2.85	4.19	1.67	2.50
7.00	5.99	1.41	4.23	5.63	1.46	3.86	5.30	1.50	3.53	5.00	1.55	3.23	4.70	1.63	2.88	4.33	1.71	2.53
8.00	6.17	1.46	4.24	5.80	1.50	3.86	5.45	1.55	3.52	5.14	1.60	3.22	4.83	1.68	2.88	4.46	1.76	2.53
9.00	6.35	1.47	4.31	5.95	1.52	3.93	5.60	1.56	3.58	5.27	1.61	3.27	4.96	1.69	2.93	4.58	1.78	2.58
10.00	6.59	1.49	4.41	6.17	1.54	4.01	5.80	1.59	3.65	5.45	1.64	3.33	5.14	1.72	2.99	4.75	1.80	2.63
11.00	6.77	1.51	4.49	6.34	1.55	4.08	5.95	1.60	3.71	5.59	1.65	3.38	5.27	1.73	3.04	4.88	1.82	2.68
12.00	6.93	1.53	4.53	6.48	1.58	4.11	6.07	1.63	3.73	5.70	1.68	3.40	5.38	1.76	3.06	4.99	1.85	2.70
13.00	7.05	1.54	4.57	6.59	1.59	4.14	6.17	1.64	3.76	5.79	1.69	3.43	5.47	1.77	3.08	5.08	1.86	2.72
14.00	7.23	1.55	4.65	6.75	1.60	4.21	6.31	1.65	3.82	5.92	1.70	3.48	5.60	1.79	3.13	5.20	1.88	2.77
15.00	7.32	1.56	4.69	6.83	1.61	4.24	6.38	1.66	3.85	5.97	1.71	3.49	5.66	1.80	3.15	5.26	1.89	2.79
16.00	7.50	1.58	4.76	6.99	1.63	4.30	6.53	1.68	3.90	6.11	1.73	3.54	5.79	1.81	3.19	5.39	1.90	2.83
17.00	7.60	1.58	4.80	7.07	1.63	4.33	6.60	1.68	3.92	6.17	1.74	3.55	5.85	1.82	3.21	5.45	1.91	2.85

Model: 7 kW

Chilled water outlet temp. (°C)	Ambient temp.(°C)																	
	21.00			25.00			30.00			35.00			40.00			46.00		
	Capacity kW	Power kW	COP W/W	Capacity kW	Power kW	COP W/W	Capacity kW	Power kW	COP W/W	Capacity kW	Power kW	COP W/W	Capacity kW	Power kW	COP W/W	Capacity kW	Power kW	COP W/W
5.00	7.84	1.98	3.95	7.38	2.04	3.61	6.96	2.11	3.31	6.58	2.17	3.03	6.17	2.28	2.70	5.67	2.39	2.37
6.00	8.10	2.01	4.03	7.62	2.07	3.67	7.18	2.14	3.36	6.78	2.21	3.08	6.36	2.32	2.75	5.86	2.43	2.41
7.00	8.38	2.05	4.08	7.88	2.12	3.72	7.42	2.18	3.40	7.00	2.25	3.11	6.57	2.36	2.78	6.06	2.48	2.44
8.00	8.64	2.12	4.09	8.12	2.18	3.72	7.63	2.25	3.40	7.20	2.32	3.11	6.76	2.43	2.78	6.24	2.56	2.44
9.00	8.89	2.14	4.16	8.34	2.20	3.79	7.84	2.27	3.45	7.38	2.34	3.15	6.94	2.46	2.83	6.42	2.58	2.49
10.00	9.22	2.17	4.26	8.64	2.23	3.87	8.12	2.30	3.52	7.64	2.38	3.22	7.19	2.49	2.88	6.65	2.62	2.54
11.00	9.48	2.19	4.33	8.88	2.26	3.93	8.33	2.33	3.58	7.83	2.40	3.26	7.38	2.52	2.93	6.83	2.64	2.58
12.00	9.70	2.22	4.37	9.07	2.29	3.96	8.50	2.36	3.60	7.98	2.43	3.28	7.54	2.56	2.95	6.99	2.68	2.60
13.00	9.87	2.24	4.41	9.23	2.31	4.00	8.64	2.38	3.63	8.10	2.45	3.30	7.66	2.58	2.97	7.11	2.70	2.63
14.00	10.12	2.25	4.49	9.45	2.32	4.06	8.84	2.40	3.69	8.28	2.47	3.35	7.83	2.59	3.02	7.28	2.72	2.67
15.00	10.25	2.27	4.52	9.56	2.34	4.09	8.93	2.41	3.71	8.36	2.48	3.37	7.92	2.61	3.04	7.37	2.74	2.69
16.00	10.50	2.29	4.59	9.79	2.36	4.15	9.14	2.43	3.76	8.55	2.51	3.41	8.10	2.63	3.08	7.54	2.76	2.73
17.00	10.64	2.30	4.63	9.90	2.37	4.18	9.24	2.44	3.78	8.63	2.52	3.43	8.19	2.65	3.10	7.64	2.78	2.75

Note: Specifications are based on the following conditions:
 Cooling : (*1) chilled water inlet/outlet: 12°C / 7°C, and outdoor ambient temp. of 35°C DB. (*2) chilled water inlet/outlet: 12°C / 7°C, and outdoor ambient temp. of 46°C DB.
 Heating : warm water inlet/outlet: 40°C / 45°C, and outdoor ambient temp. 7°C DB/6°C WB.

Model: 5 kW

Hot water outlet temp. (°C)	Ambient temp.(°C)																				
	-10			-6			-2			7			10			13					
	Capacity kW	Power kW	COP W/W	Capacity kW	Power kW	COP W/W	Capacity kW	Power kW	COP W/W	Capacity kW	Power kW	COP W/W	Capacity kW	Power kW	COP W/W	Capacity kW	Power kW	COP W/W			
40.00	3.85	1.19	3.24	4.81	1.35	3.56	5.66	1.50	3.77	6.28	1.63	3.85	6.83	1.72	3.98	7.65	1.82	4.20	8.80	1.97	4.48
41.00	3.72	1.21	3.07	4.66	1.38	3.38	5.49	1.53	3.58	6.11	1.66	3.67	6.65	1.75	3.79	7.43	1.86	4.00	8.53	2.01	4.25
42.00	3.62	1.24	2.92	4.53	1.41	3.22	5.34	1.56	3.42	5.95	1.70	3.50	6.48	1.79	3.63	7.24	1.90	3.82	8.29	2.05	4.05
43.00	3.53	1.26	2.79	4.43	1.44	3.09	5.23	1.59	3.28	5.83	1.73	3.36	6.36	1.82	3.48	7.08	1.93	3.66	8.10	2.09	3.88
44.00	3.46	1.29	2.69	4.35	1.46	2.97	5.14	1.63	3.16	5.74	1.77	3.24	6.26	1.86	3.36	6.96	1.97	3.53	7.95	2.13	3.73
45.00	3.41	1.32	2.59	4.29	1.49	2.87	5.08	1.66	3.06	5.67	1.81	3.14	6.20	1.90	3.26	6.88	2.01	3.42	7.85	2.18	3.61
46.00	3.34	1.33	2.52	4.21	1.51	2.79	4.99	1.68	2.98	5.58	1.82	3.06	6.11	1.92	3.18	6.77	2.03	3.33	7.70	2.20	3.51
47.00	3.25	1.35	2.40	4.09	1.54	2.66	4.85	1.71	2.84	5.44	1.86	2.92	5.95	1.96	3.04	6.59	2.07	3.17	7.48	2.24	3.34
48.00	3.12	1.40	2.23	3.94	1.59	2.48	4.67	1.76	2.65	5.24	1.92	2.74	5.75	2.02	2.85	6.34	2.14	2.97	7.19	2.31	3.12
49.00	2.95	1.45	2.03	3.73	1.65	2.26	4.43	1.83	2.42	4.97	1.99	2.50	5.46	2.10	2.60	6.02	2.22	2.71	6.81	2.40	2.84
50.00	2.76	1.52	1.81	3.49	1.73	2.02	4.16	1.92	2.16	4.67	2.09	2.23	5.13	2.20	2.33	5.64	2.33	2.42	6.38	2.52	2.53

Model: 7 kW

Hot water outlet temp. (°C)	Ambient temp.(°C)																				
	-10			-6			-2			7			10			13					
	Capacity kW	Power kW	COP W/W	Capacity kW	Power kW	COP W/W	Capacity kW	Power kW	COP W/W	Capacity kW	Power kW	COP W/W	Capacity kW	Power kW	COP W/W	Capacity kW	Power kW	COP W/W			
40.00	4.96	1.56	3.17	6.20	1.78	3.49	7.30	1.98	3.70	8.11	2.15	3.78	8.81	2.26	3.90	9.87	2.40	4.12	11.35	2.59	4.39
41.00	4.81	1.60	3.01	6.01	1.81	3.32	7.08	2.02	3.51	7.88	2.19	3.60	8.57	2.31	3.72	9.59	2.44	3.92	11.00	2.64	4.17
42.00	4.67	1.63	2.87	5.85	1.85	3.16	6.90	2.06	3.35	7.68	2.24	3.44	8.37	2.35	3.56	9.34	2.49	3.74	10.70	2.69	3.97
43.00	4.55	1.66	2.74	5.71	1.89	3.03	6.75	2.10	3.21	7.52	2.28	3.30	8.20	2.40	3.42	9.14	2.55	3.59	10.45	2.75	3.80
44.00	4.47	1.70	2.63	5.61	1.93	2.91	6.63	2.14	3.10	7.40	2.33	3.18	8.08	2.45	3.30	8.98	2.60	3.46	10.26	2.80	3.66
45.00	4.40	1.73	2.54	5.54	1.97	2.82	6.55	2.19	3.00	7.32	2.38	3.08	8.00	2.50	3.20	8.88	2.65	3.35	10.12	2.86	3.54
46.00	4.31	1.75	2.47	5.43	1.99	2.74	6.44	2.21	2.92	7.20	2.40	3.00	7.88	2.53	3.12	8.73	2.68	3.26	9.94	2.89	3.44
47.00	4.19	1.78	2.35	5.28	2.03	2.61	6.26	2.25	2.78	7.01	2.45	2.87	7.68	2.58	2.98	8.50	2.73	3.11	9.65	2.95	3.27
48.00	4.02	1.84	2.19	5.08	2.09	2.43	6.03	2.32	2.60	6.76	2.52	2.68	7.41	2.65	2.79	8.19	2.81	2.91	9.28	3.04	3.06
49.00	3.80	1.91	1.99	4.81	2.17	2.22	5.72	2.41	2.37	6.42	2.62	2.45	7.04	2.76	2.55	7.76	2.92	2.65	8.79	3.16	2.78
50.00	3.56	2.01	1.77	4.50	2.28	1.98	5.36	2.53	2.12	6.02	2.75	2.19	6.62	2.90	2.29	7.28	3.07	2.37	8.23	3.32	2.48

Note: Specifications are based on the following conditions:

Cooling : (*1) chilled water inlet/outlet: 12°C / 7°C, and outdoor ambient temp. of 35°C DB. (*2) chilled water inlet/outlet: 12°C / 7°C, and outdoor ambient temp. of 46°C DB.
 Heating : warm water inlet/outlet: 40°C / 45°C, and outdoor ambient temp. 7°C DB/6°C WB.

Air conditioner operating conditions

For proper performance, run the air conditioner under the following temperature conditions

Cooling operation	Outdoor temperature: -5°C~46°C
	water outlet temperature: 4°C~20°C
Heating operation	Outdoor temperature: -15°C~27°C
	water outlet temperature: 30°C~55°C

If air conditioner is used beyond the above conditions, safety protection features may come into operation

Note:When the outdoor temperature is too low, the unit in standby mode will activate frost protection, forced to run pumps or forced heating operation to protect the unit water system.

RECOMMENDED OPERATING AREA

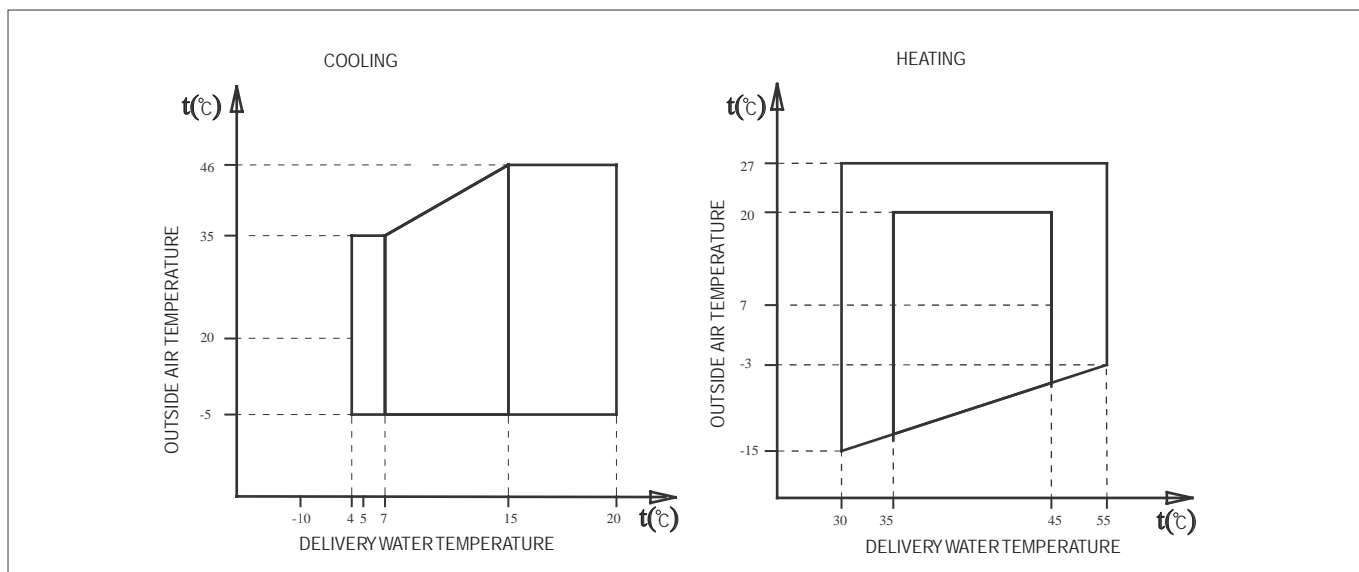

Thermal head min.- max.	4-6
Water circuit pressure (bars)	1-3
Max.storage temperature	60

ETHYLENE GLYCOL SOLUTIONS

Water and ethylene glycol solutions used as a thermal vector in the place of water reduce the performance of the unit. Multiply the performance figures by the values given in the following table.

Freezing point (°C)						
	0	-5	-10	-15	-20	-25
Percentage of ethylene glycol in weight						
	0	12%	20%	28%	35%	40%
cPf	1	0.98	0.97	0.965	0.96	0.955
cQ	1	1.02	1.04	1.075	1.11	1.14
cdp	1	1.07	1.11	1.18	1.22	1.24

cPf: correction factor refrigerating capacity
 cQ: correction factor flow rate
 cdp: correction factor pressure drop



During winter leaving the unit unused, please drain water out completely from unit if no antifreeze were charged into pipeline, or keep power on (at standby or off status) and ensure that water is contained inside of unit.

When ambient temperature lower 5°C running cooling mode must be charged antifreeze. Refer to upper parameters for the charged volume.

FOULING FACTORS

The performance data given refer to conditions with clean evaporator plates (fouling factor=1). For different fouling factors, multiply the figures in the performance tables by the coefficient given in the following table.

Fouling factors (m ² °C/W)	Evaporator		
	f1	fk1	fx1
4.4 x 10 ⁻⁵	-	-	-
0.86 x 10 ⁻⁴	0.96	0.99	0.99
1.72 x 10 ⁻⁴	0.93	0.98	0.98

f1 capacity correction factor

fk1 compressor power input correction factor

fx1 total power input correction factor

Minimum water volume

Model	5kW	7kW
-------	-----	-----

Minimum water volume L	21	30
------------------------	----	----

If the total water volume in the system is less than the value in the table above, the additional water tank is necessary in order to avoid the compressor On and Off frequently.

The minimum size of the water tank is calculated as:
 Size of additional water tank(L) = Minimum water volume(L) - Actual water volume(L)

I A

HYDRAULIC DATA

USEFUL PUMP HEAD CURVES (5/7 kW)

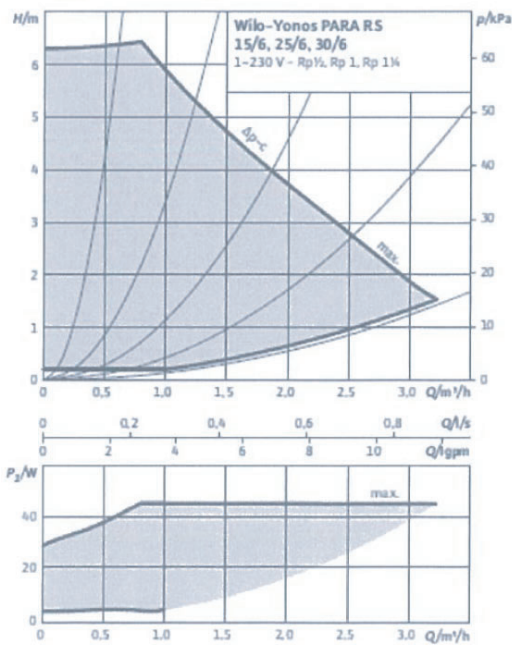

(*) To obtain the useful head of the installation, subtract the pressure drop of the plate heat exchanger.

HEAT EXCHANGER PRESSURE DROP (WATER SIDE)

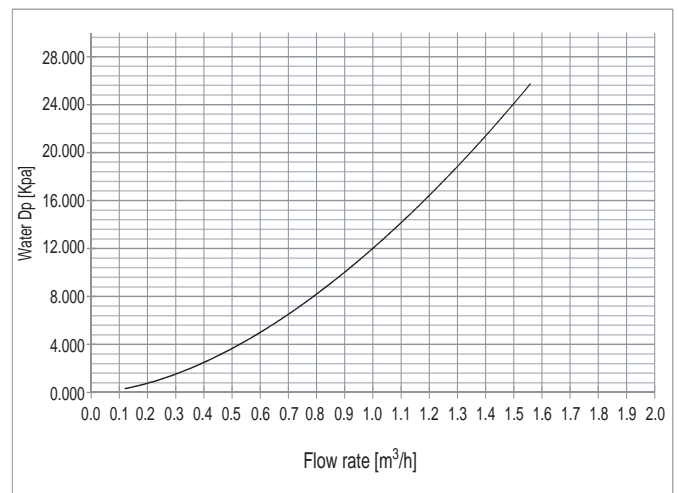

Note: the values highlighted refer to the rated flow

I A

REFRIGERANT CIRCUIT

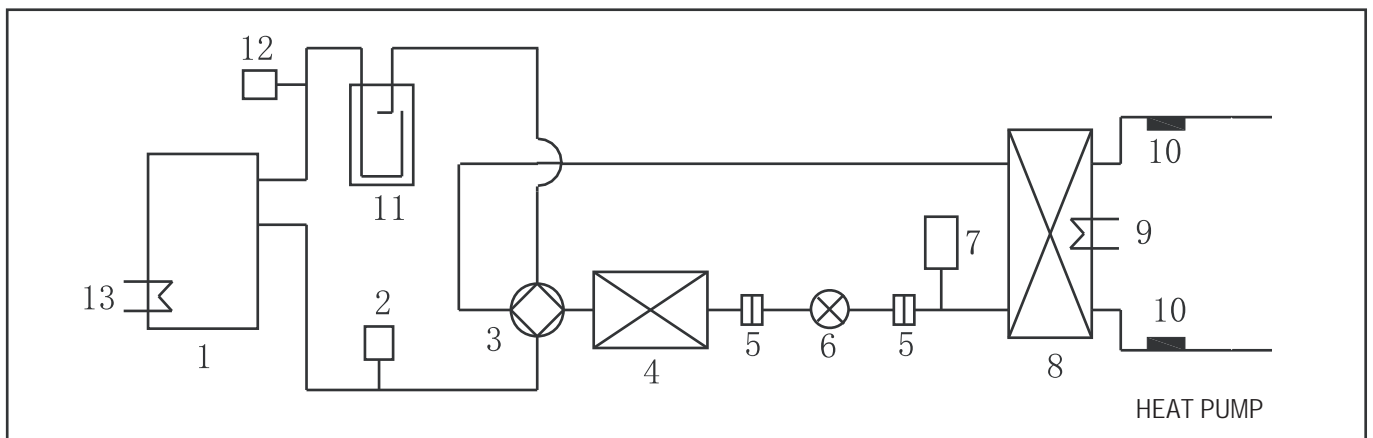

1 compressor	6 electric expansive value	11 accumulator
2 high pressure switch	7 liquid receiver	12 low pressure switch
3 reversing value(only HEAP PUMP)	8 plate heat exchanger	13 sump heater
4 condenser	9 frost heater	
5 filter	10 water temperature sensor	

CHECKING AND STARTING UP THE UNIT A

PREPARING FOR FIRST START UP

Restarting after shutting down for long periods
 The chiller must be started up for the first time by the Technical Service. Before starting up the chillers, make sure that:

- All safety conditions have been respected
 - The chiller is adequately fixed to the surface it rests on
 - Functional distances have been respected;
 - Hydraulic connections have been carried out as indicated in the instruction manual
 - The water circuit is filled and vented. When draining after heat pump operation, take care as the water may be hot;
 - The water circuit valves are open
 - Electrical connections have been carried out correctly
 - Voltage is within a tolerance of 10% of the rated voltage for the unit
 - The unit is correctly earthed
 - All electrical and hydraulic connections are tight and have been completed correctly.
- Use grommet A for the electrical power cable and grommet B for the other external wires.

To complete the electrical connections:
 - Remove the inspection panel by unscrewing the five screws

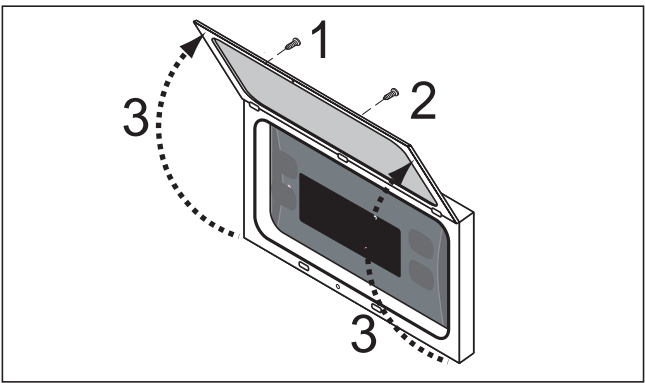
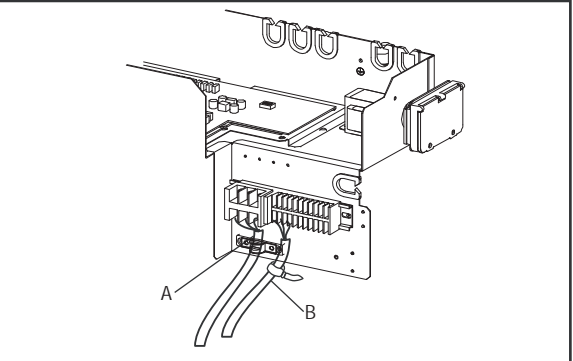
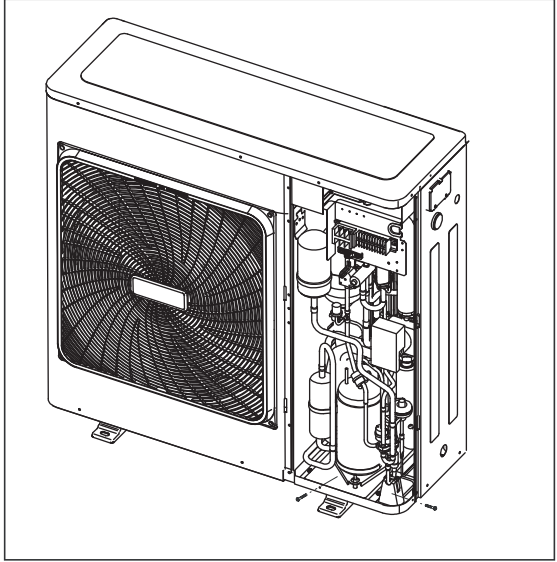

To access the control panel, open the door:
 -remove the screw 1 and screw 2;
 -lift the door 3.



ACTIVATING AND DEACTIVATING THE UNIT U I A

I. Icon Description

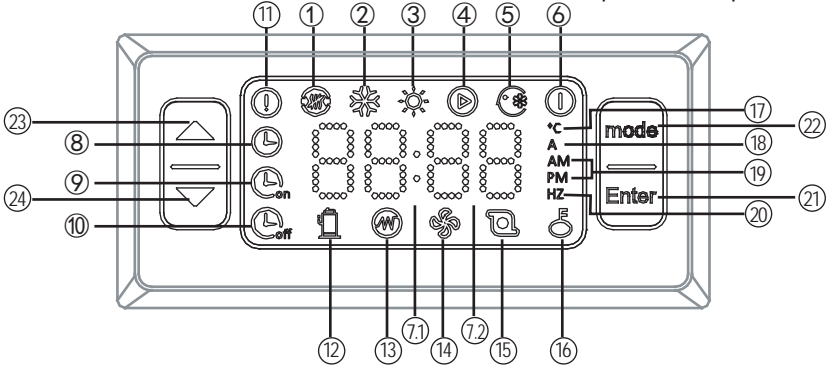
The front panel of the device functions as the user interface and is used to perform all operations relating to the device.



NO.	Icon	Description
①		Outside heat source running icon(Reserved)
②		Cooling mode icon This icon will be constantly light when customers choose cooling mode.
③		Heating mode icon This icon will be constantly light when customers choose heating mode.
④		Water pump mode icon This icon will be constantly light when customers choose water pump mode.
⑤		Force cooling icon This icon will be constantly light when customers choose force cooling mode.
⑥		Power off icon This icon will be constantly light when customers choose Power off mode.
⑦		Clock icon, the middle“: ” flicker once every 1s. It will display time when customers set the timer.
⑦ ²		The last 2 digits of the nixie tube “88” icon. If “88” is constantly light, it will display the current inlet water temperature. Its unit is °C . When customers do water temperature set, icon will display the set water temperature. When checking, “88” will display the result of checking. When water heating is broken down or in protection, “88” display the error code and protection code.
⑧		Clock icon It will display when finish setting the clock and be extinguished when the clock setting work is done.
⑨		Timing on function icon will flicker when setting timing on. The icon will be constantly light when finish setting.
⑩		Timing off function icon will flicker when setting timing off. The icon will be constantly light when finish setting.
⑪		Breakdown light icon When the unit is broken down or under protection, this icon will flicker and will be extinguished when malfunction and protection are eliminated.
⑫		Compressor booting indicator icon When booting the compressor, this icon will be constantly light. It will be extinguished when the compressor is shut down
⑬		E-heater booting indicator icon (Reserved) When booting the external E-heater, this icon will be constantly light. It will be extinguished when the external E-heater is shut down.
⑭		Fan booting indicator icon When booting the fan, this icon will be constantly light. It will be extinguished when the fan is shut down.
⑮		Water pump booting indicator icon When booting the water pump, this icon will be constantly light. It will be extinguished when the water pump is shut down.
⑯		Key freezing icon When freezing the keys, this icon will be constantly light. It will be extinguished when unfreezing keys.
⑰		Temperature unit icon When the control panel displays temperature, this icon will be constantly light.
⑱		Current unit icon When the control panel displays current, this icon will be constantly light.
⑲		Time format icon The unit is 12-hour format. “AM ”will be constantly light when it is forenoon. “ PM” will be constantly light when it is afternoon
⑳		Frequency unit icon It will be constantly light when the control panel displays frequency of the compressor.
㉑		ON/OFF and OK button 1.Long press “” for 3S will power on or off the controller. 2.Press “” to confirm the former operation when finishing the setting work.
㉒		Mode choice function/Function choice/Back function button 1.Mode choice function. Choose operation mode. 2.Function choice. Long press it for 3s to enter function setting in the main interface.(Clock setting, Timing on and timing off setting) 3.Back to the previous menu. Long press it for 3s to back to previous menu in the function setting interface. Top menu is the main interface.

NO.	Icon	Description
23		Up 1.(Value increase) 2.Forward to the previous interface.
24		Down 1.(Value decrease) 2.Backward to the next interface.

II. Control panel operation description



1) ON/OFF

Operation mode one:

Power off: Long press “**Enter**” for 3s in the main interface. The panel displays “OFF” and other icons will be extinguished. The unit stops.



Power on: When the display panel shows “OFF”, long press “**Enter**” for 3s and wait for the unit to enter standby mode. Then power on the unit according to Operation mode two.

Operation mode 2:



Power off: Press “**mode**” in the main interface to enter mode choice function and the icon which indicate the current mode will flicker. Press “**mode**” circularly to choose power off mode, “” will flicker at this moment. Press “**Enter**” button to confirm the power off mode. By this time, “” will be constantly light and the unit stops.

Power on: In the power off mode, press “**mode**” to enter mode choice function. Press “**mode**” circularly to choose one kind of “power on” mode, the mode icon will flicker at the moment. Press “**Enter**” to confirm the power on mode. The unit will run as the chosen mode when the mode icon will be constantly light.





2) Mode choice and temperature settings

Press “**mode**” in the main interface to enter mode choice function. The “Mode” icon will flicker. Click “**mode**” circularly to choose a mode. The circulating order is “Cooling mode”→“Heating mode”→“Water pump mode”→“Power off mode”→“Cooling mode”. The chosen mode will flicker. Press “” or “” to increase/decrease the temperature in the chosen mode.

Press “**Enter**” to confirm power off mode and the set temperature. Mode icon will be constantly light and the unit will run as the chosen mode.



Press “” or “” in the main interface to increase/decrease the temperature in the chosen mode.

3) Clock setting

Long press “**mode**” for 3s to enter function interface. “” clock icon will flicker. Press “**Enter**” to enter clock setting function. “” icon will be constantly light and the first 2 digits on nixie tube will flicker. Press “” or “” to set minute. Press “**Enter**” when finish setting and “” will be extinguished.

4) Timing setting



1. Timing on setting





① Long press “**mode**” for 3s to enter function interface. “” clock icon will flicker. Press “**mode**” again to enter timing on function. “” will flicker and press

“**Enter**” to enter timing on setting.



② At this moment, last 2 digits of the nixie tube display “01” which means the first group setting begins. Press “**Enter**” to the next step.

③ By this time, mode icon will flicker and press “**mode**” to choose timing on mode. Press “**Enter**” to confirm your choice and go to the next step.

④ By this time, the last 2 digits of the nixie tube will flicker and press “” or “” to adjust temperature and set the temperature of the inlet water. Press “**Enter**” to confirm and move to the next step.

⑤ By this time, the first 2 digits of the nixie tube will flicker and press “” or “” to adjust time of timing on. Press “**mode**” to confirm and switch to minute setting automatically. The last 2 digits of the nixie tube will flicker and press “” or “” to adjust minute setting of timing on. (minimal unit of minute adjustment: 15 minutes) .

⑥ Press “**Enter**” to confirm. The first group setting is finished and “” will be constantly light.





When processing the second timing setting, repeat the 1-2 operation above. When the nixie tube displays “01” and flicker, press “” or “” to choose the timing on group. When the nixie tube displays “02” which means setting timing on function of the second group. Refers the timing on setting operation of group 1 to set that of group 2.



• Long press “**mode**” for 3s to return to the previous interface to reset the parameter during setting clock timing.

2. Timing off setting

① Long press “**mode**” for 3s in the main interface to enter function interface. Press “**mode**” circularly to enter timing off function. “” will flicker and press “**Enter**” to enter timing off setting.

② At this moment, the last 2 digits of the nixie tube display “01” which means the first group setting begins. Press “**Enter**” to the next step.



③ By this time, the first 2 digits of the nixie tube will flicker and press “” or “” to adjust time of timing off. Press “**mode**” to confirm and switch to minute setting automatically. The last 2 digits of the nixie tube will flicker and press “” or “” to adjust minute setting of timing off. Press “**Enter**” to confirm. The first group setting is finished and “” will be constantly light.



④ When processing timing setting of group 2, repeat the 1-2 operation above. When the nixie tube displays “01” and flicker, press “” or “” to choose the timing off group. When the nixie tube displays “02” which means setting timing off function of the second group.

Refers the timing off setting operation of group 1 to set that of group 2.

3.Cancel all timing on/off settings

Long press “mode” for 3s to enter function interface.

“” clock icon will flicker and press “mode” to choose the timing function. “” and “” flicker simultaneously means choosing to cancel all timing functions.

Press “Enter” to cancel timing settings. “” and “” both will be extinguished.

III.Functions of combination key



1.Force cooling



Press “” and “mode” simultaneously for 3s in the main interface to enter into force cooling mode. The force cooling mode icon will be constantly light.

Press “” button and “mode” button simultaneously for 3s to quit force cooling mode. The unit will enter power off mode automatically when quitting force cooling mode.

2.Parameter query function

①To enter parameter query function

Press “” and “” simultaneously for 3s to enter into the interface of parameter query function. At this moment, first 2 digits of the nixie tube  will display sequence number and the last 2 digits is specific parameters.

Press “” or “” to query the relative parameters. See query orders in Table 1-1.

②Quit parameter query function

If there's no operation in 20s when enter the parameter query, it will quit automatically and return to the main interface.



Press “” and “” simultaneously to quit parameter query manually.

Table.1-1 Query orders

No.	Content	Remark
1	Frequency	Show inlet water temperature when the unit is in standby mode and water pump mode. Display operating frequency when the unit is in cooling mode and heating mode. When defrosting displays dF. Display Pb when running anti-freezing.
2	Mode	0-Power off, 1-water pump, 2-cooling, 3-heating, 4-force cooling
3	Wind speed level	0-Power off (1-7)
4	Total capacity requirements	Capacity before revised(Force cooling displays 5)
5	Capacity requirements after revised	Capacity after revised (Force cooling displays 5)
6	Temp. set	Cooling/heating temp. set
7	T3	Outlet temperature of outdoor heat exchanger
8	T4	Outdoor environment temperature
9	Tp	Temperature
10	Tin	Water inlet temperature of water to water plate heat exchangers
11	Tout	Water outlet temperature of water to water plate heat exchangers
12	Tb1	Temperature 1 of plate heat exchangers
13	Tb2	Temperature 2 of plate heat exchangers(equals to Tb1)
14	T6	Cooling fin surface temperature(reserved)
15	Unit operation current	Unit operation current
16	Power supply voltage AD value	Power supply voltage AD value
17	Opening of EXV	Step number *8
18	Model	5: 5kW 7:7kW
19	Version number	
20	Err1	
21	Err2	
22	Err3	

3.Auto-lock(unlock) function

If don't operate the controller in 60s, the keyboard will lock automatically. Press “mode” and “Enter” simultaneously for 3s to unlock.

4.Error code and protection code shooting table:

E9	EEPROM error
HL	PFC module error
Hb	Communication error between the outdoor unit and the wire controller(reserved)
H0	Communication error between the main controlling chip and IPDU
E4	T3,T4 sensor error
E5	Voltage protection error
E6	DC fan error
EA	5-minute error for heating mode fan in area A
Eb	Two times of E6 errors in 10 minutes(Recover when powering off)
HH	Tin sensor error
EC	Tout sensor error
C0	Tb1 sensor error
C1	Tb2 sensor error
PL	High temp. protection of cooling fin
P1	High voltage protection
P2	Low voltage protection
P3	Current protection of compressor
P4	Discharge temperature protection
P5	Outdoor condenser T3 high temperature protection
P6	IPDU module protection(For the detailed information, please run check function)
P8	Typhoon protection
CH	Low water temperature protection in cooling mode
CL	High inlet and outlet water temperature difference protection in cooling mode
CP	Plate heat exchangers anti-freezing protection
Pb	System anti-freezing protection
C8	Paddle flow switch error
PH	High temperature protection in heating mode
dF	Defrosting
d8	Remote control

OPERATING CHARACTERISTICS



Set point in cooling

(factory set) = 12°C,Hysteresis = 3°C.

The compressor starts with water temperatures above 12°C.

The compressor shuts down with water temperatures of less than 9°C.

Set point in heating

(factory set) = 40°C,hysteresis = 4°C.

The compressor starts with water temperatures below 38°C.

The compressor shuts down with water temperatures above 42°C.

In the event of a temporary power failure,when power returns,the mode set previously will be retained in the memory.

COMPRESSOR START UP DELAY

Two functions prevent the compressor from starting up too frequently

-Minimum time since last start-up 300 seconds.

PUMP

The electronic board includes a pump control output.The pump starts when the assembly is powered up and at least 285 seconds before the compressor starts up and stops 120 seconds after the assembly shuts down.

After the first 120 seconds of pump operation when the water flow is at full speed,the water flow alarm functions are activated (differential pressure switch and flow switch). With a pump connected to terminals PL and PN on the installer terminal board.

FAN SPEED CONTROL

For correct operation of the unit with different outside temperatures,the microprocessor controls the fan speed

based on the pressure reading from the pressure probe, thus enabling heat exchange to be increased and/or decreased, maintaining the condensing or evaporation temperature practically constant.

The fan functions independently of the compressor.

FROST PREVENTION ALARM

To prevent the water freezing and damaging the plate heat exchanger, the microprocessor shuts down the compressor if the temperature measured by the heat exchanger outlet temperature sensor is less than 3°C.

The frost prevention temperature set point can be modified by an authorised service centre only and only after verifying that the water circuit contains antifreeze.

Tripping of this alarm shuts down the compressor but not the pump, which remains active.

To reset normal functions, the outlet water temperature must rise to more than +15°C. Reset is manual.

WATER FLOW ALARM

The microprocessor provides for management of a water flow alarm controlled by a water flow switch fitted as standard on the appliance and a flow switch to be installed on the water delivery piping.

This safety device may trip after the first 120 seconds of pump operation when the water flow is up to speed.

Tripping of this alarm shuts down the compressor but not the pump, which remains active.

To reset normal functions, the alarm contact must be deactivated for at least 15 seconds.

When condenser temperature over than 62°C, system will shut down, but not returns to normal operation until the condenser temperature decreased less than 52°C.

A

SHUTTING DOWN FOR LONG PERIODS

If it is previewed not to use the machine for long periods After deactivating the chiller:

- Make sure the model is in the Power off model "ⓐ", or alternatively disconnect the unit from the power supply.
- Make sure the remote control switch is closed (if present).
- Close the water valves.



If there is a possibility that the outside temperature may drop below zero, there is the risk of freezing. The water circuit **MUST BE EMPTIED AND SHUT OFF POWER** (when draining after heat pump operation take care as the water may be hot) or antifreeze must be added in the proportion recommended by the manufacturer.

A

ROUTINE MAINTENANCE

Never perform any cleaning operations before having disconnected the unit from the mains power supply.

If the supply cord is damaged, it must be replaced by the manufacturer or its service agent or a similarly qualified person in order to avoid a hazard.

Regular maintenance is fundamental to maintain the efficiency of the unit both in terms of operation and energy consumption. The Technical Assistance Service maintenance plan must be observed, with an annual service which includes the following operations and checks:

- Filling of the water circuit
- Presence of air bubbles in the water circuit
- Efficiency of safety devices
- Power supply voltage

- Power input
- Tightness of electrical and hydraulic connections
- Condition of the compressor contactor
- Efficiency of the plate heat exchanger heater
- Checking of operating pressure, superheating and subcooling
- Efficiency of compressor heater
- Cleaning of finned coil (*)
- Cleaning of fan grills
- Cleaning of condensate drain pan (if installed).

(*) for "Heat pump" appliances, the checks are to be performed quarterly.

For units installed near the sea, the intervals between maintenance should be halved.

A

EXTRAORDINARY MAINTENANCE

Never perform any cleaning operations before having disconnected the unit from the mains power supply.

CHEMICAL WASHING

You are recommended to chemically wash the plate heat exchanger after every 3 years of operation. For instructions on how to carry out this operation, contact De'Longhi Spa.

REFRIGERANT GAS CONTENT

The chillers are filled R410A refrigerant gas and tested in the factory. In normal conditions, there should be no need for the Technical Assistance Service to intervene to check the refrigerant gas. However, over time, small leaks may develop at the joints leading to loss of refrigerant and drain-

ning of the circuit, causing the unit to function poorly. In this case, the leaks of refrigerant must be identified and repaired and the refrigerant circuit refilled. Proceed as follows:

- Empty and dry the entire refrigerant circuit using a vacuum pump connected to the low and high pressure tap until the vacuum meter reads about 10 Pa. Wait a couple of minutes and check that this value does not rise to more than 200 Pa.
- Connect the refrigerant gas cylinder or a filling cylinder to the low pressure line pressure gauge connection.
- Fill with the quantity of refrigerant gas indicated on the rating plate of the unit.
- Always check the superheating and subcooling values. In the nominal operating conditions for the appliance, these should be between 5 and 10°C and between 4 and 8°C respectively.
- After a couple of hours of operation, check that the liquid indicator indicates circuit dry (dry-green)



In the event of partial leaks, the circuit must be completely emptied before being refilled. The R410a refrigerant must only be filled in the liquid state.

Operating conditions other than nominal conditions may produce considerably different values. Seal testing or identification of leaks must only be carried out using R410a refrigerant gas, checking with a suitable leak detector.



The refrigerant circuit must not be filled with a refrigerant other than that indicated on page 14. The use of a different refrigerant may cause serious damage to the compressor.

Oxygen, acetylene or other inflammable or poisonous gases must never be used in the refrigerant circuit as they may cause explosion or poisoning.

Oils other than those indicated on pages 14 must not be used. The use of different oils may cause serious damage to the compressor.

DISPOSAL

A

Do not dispose this product as unsorted municipal waste. Collection of such waste separately for special treatment is necessary

Do not dispose of electrical appliances as unsorted municipal waste, use separate collection facilities.

Contact your local government for information regarding the collection systems available.

If electrical appliances are disposed of in landfills or dumps, hazardous substances can leak into the groundwater and get into the food chain, damaging your health and well-being.



