

# Airwell

*Just feel well*

2018/2019  
Saudi arabia  
catalog

# Airwell

AIR CONDITIONING & HEATING

Airwell makes life easier  
with dedicated services

## Professionnals



### INTERNET WEBSITE

Order easier online

■ [www.airwell-pro.com](http://www.airwell-pro.com)



### TECHNICAL DOCUMENTATION

Find here all the documentation you need

■ <http://lh.airwell-res.com/>



### PROJECTS SERVICE

tel ■ [+33 \(0\)1 76 21 82 82](tel:+330176218282)



### TRAININGS



■ [www.airwell-academy.fr](http://www.airwell-academy.fr)

e-mail ■ [airwell-academy@airwell-res.com](mailto:airwell-academy@airwell-res.com)



### AFTER-SALES SERVICE

tel ■ [+33 \(0\)1 76 21 82 95](tel:+330176218295)

From Monday to Friday, from 9 am to 12:30 pm and from 2 to 5pm

■ **Parts orders:** [sp@airwell-res.com](mailto:sp@airwell-res.com)

■ **Technical support:** [sav@airwell-res.com](mailto:sav@airwell-res.com)

## Consumers



### INTERNET WEBSITE

■ [www.airwell-res.com](http://www.airwell-res.com)



### SELECTION ASSISTANT

■ **3D designer:**

Simulate in 3D your air conditioning from home

■ **White paper**

The expertise of a french brand



An international sales network

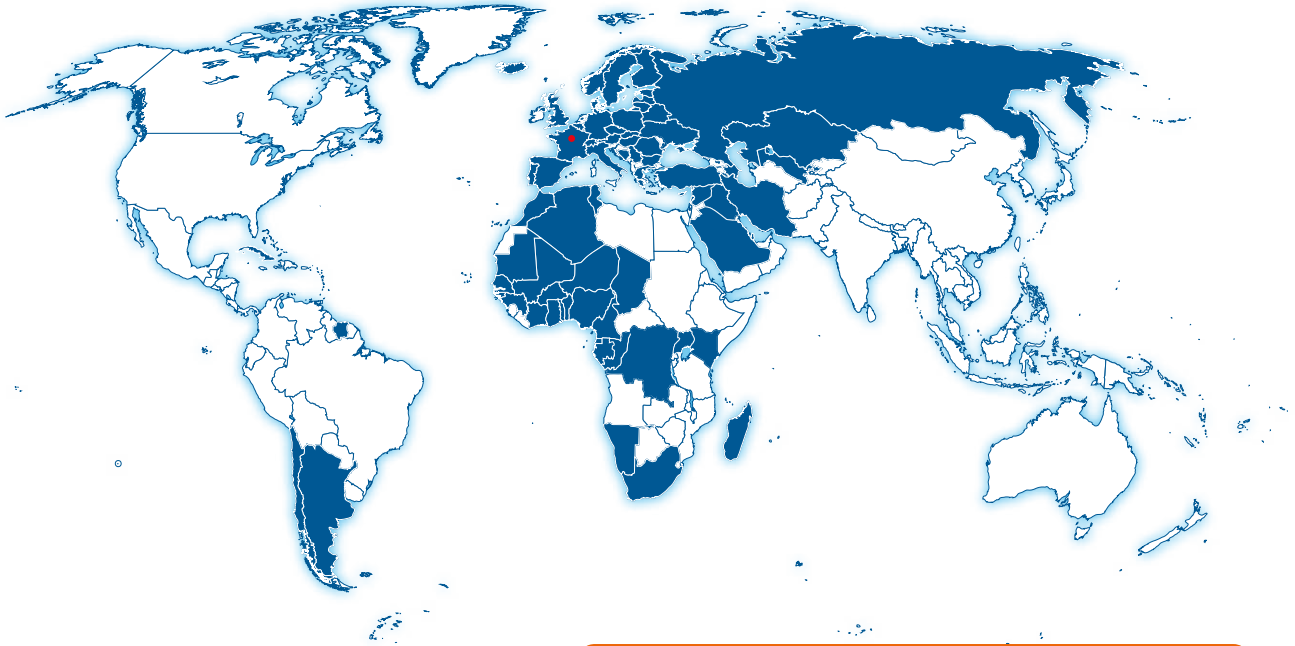

Find our partners on [www.airwell-pro.com](http://www.airwell-pro.com)

#### HEADQUARTERS

3, avenue du Centre  
Les Quadrants - Bâtiment A  
78280 Guyancourt - FRANCE

#### GENERAL CONTACT

tel ■ **+33 (0)1 76 21 82 00**  
e-mail ■ **contact@airwell-res.com**

#### OUR PARTNERS











**Blygold**<sup>®</sup>

#### OUR CERTIFICATIONS



# Table of contents



	Page
<b>HISTORY</b>	6
<b>SERVICES DIVISION</b>	8
<b>HIGH WALL RANGE</b>	14
 <b>HFT FIXED SPEED T3</b>	ON/OFF high wall 16
 <b>HDT INVERTER T3</b>	DC Inverter high wall 18
<b>DUCTED RANGE</b>	20
 <b>DDT INVERTER T3</b>	DC Inverter ducted T3 22
<b>VRF RANGE</b>	24
<b>Outdoor units:</b>	24
<b>FlowLogic III T3 section</b>	Top discharge 10-14-16-18-20-24 HP 32
<b>Water FlowLogic</b>	Water condensing VRF 36
<b>Indoor units:</b>	26
<b>HBV</b> R410A	High wall 38
<b>CBV</b> R410A	Cassette 600x600 39
<b>CCV</b> R410A	Cassette 900x900 40
<b>CFV</b> R410A 	Cassette 360° 41
<b>FAV</b> R410A	Floor ceiling 42
<b>DDV</b> R410A 	Ducted low static pressure 43
<b>DBV</b> R410A 	Ducted medium static pressure 44
<b>DCV</b> R410A	Ducted high static pressure 45
<b>EAV</b> R410A 	Console 46
<b>AHU connection kit</b>	48
<b>Central control solutions</b>	50
<b>ACCESSORIES</b>	52
 Installation accessories	52
 Control systems	54
<b>TOOL BOX</b>	58
<b>ICON GUIDE</b>	62

# History

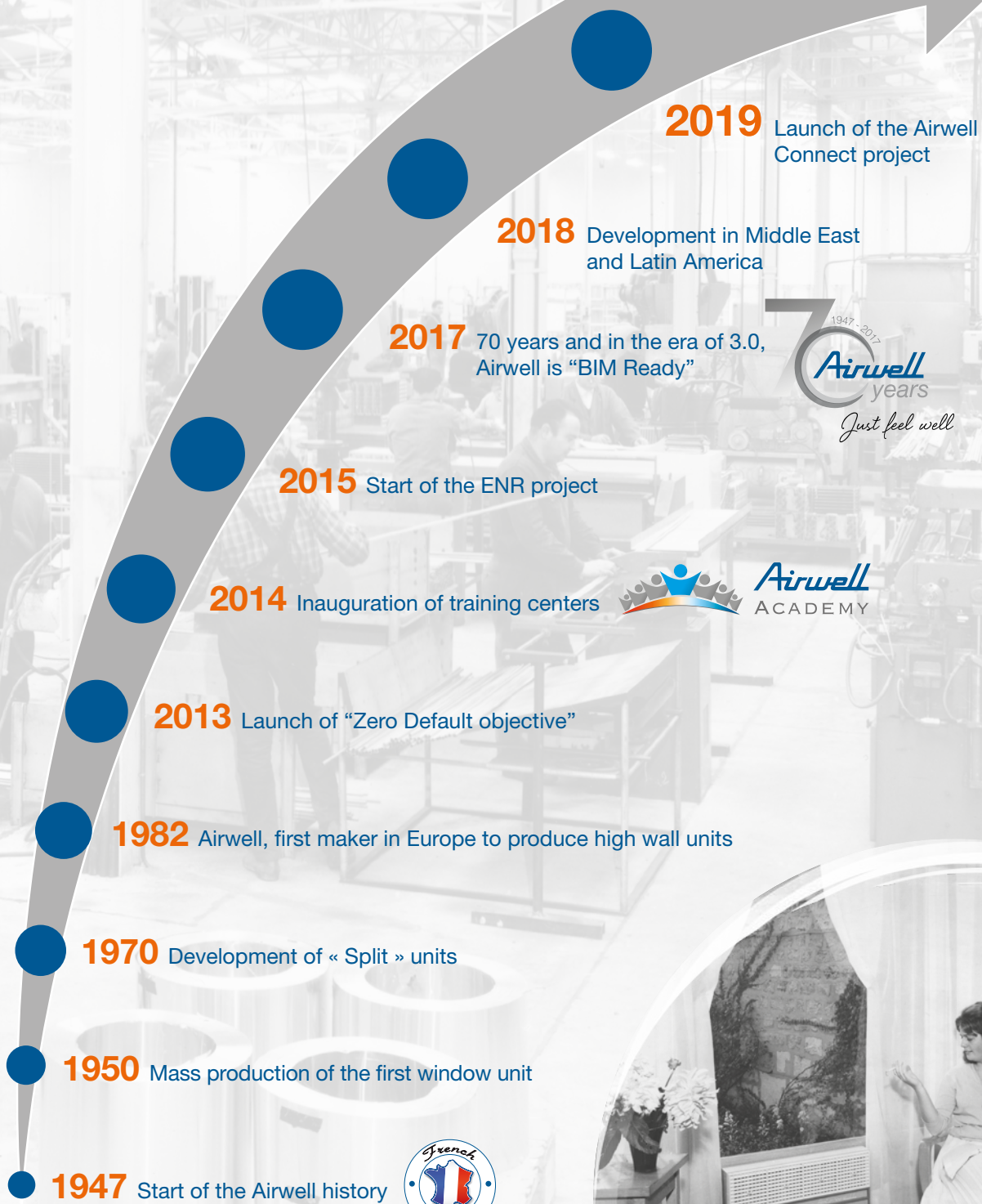

## Your french expert FOR MORE THAN 70 YEARS

- 
- 2019** Launch of the Airwell Connect project
  - 2018** Development in Middle East and Latin America
  - 2017** 70 years and in the era of 3.0, Airwell is "BIM Ready"
  - 2015** Start of the ENR project
  - 2014** Inauguration of training centers
  - 2013** Launch of "Zero Default objective"
  - 1982** Airwell, first maker in Europe to produce high wall units
  - 1970** Development of « Split » units
  - 1950** Mass production of the first window unit
  - 1947** Start of the Airwell history



# Airwell

*your expert...*

## TRADE

*Airwell makes every effort to make life easier for its customers.*

*From the selection of the solution to the maintenance, through training, Airwell accompanies you in all stages of your air conditioning and heating project.*



## CERTIFICATIONS

Airwell is recognized for its reliability, certified **ISO 9001-2015**, at the level of marketing, after-sales service and training.



ISO 9001 - 2015 is a standard that establishes the requirements for a quality management system. It guarantees high efficiency and overall satisfaction of our customers.

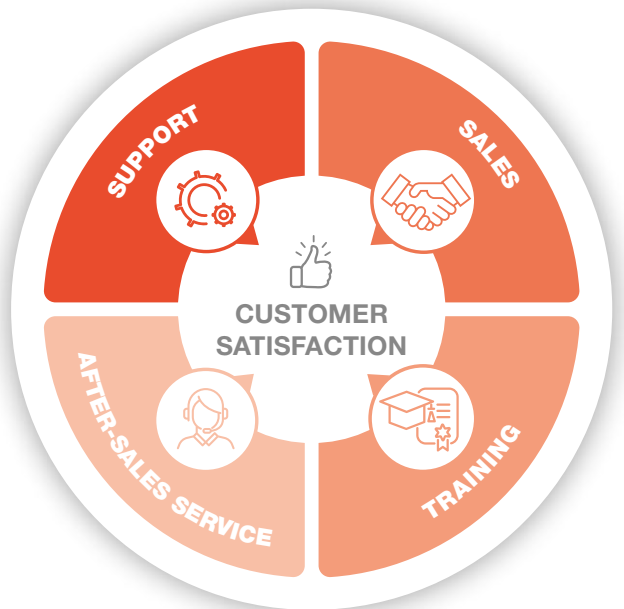

## PRE-SALES

Airwell is at your disposal to assist you in the realization of your projects (residential, hotels, businesses, industrial...).

Upstream, the Pre-Sales department studies your projects, recommending the best technical solutions.

With the help of the selection software, the Pre-Sales team assists you in the design of residential and light commercial air conditioning systems.



**CUSTOMER  
NEED**



**ACCOMPANYING  
THERMAL STUDY**  
*Airwell*



**PRODUCT  
SELECTION**  
*Airwell*



**QUOTATION**  
*Airwell*



**CUSTOMER  
SATISFACTION**



## F-GAS

# FGAS

CERTIFICATION

The F-Gas regulation (EU 517/2014) came into effect on the 1<sup>st</sup> of January 2015.

Refrigerants are man-made gases that can stay in the atmosphere for centuries and contribute to the overall greenhouse effect. There are three types: hydrofluorocarbons (HFCs), perfluorocarbons (PFCs) and sulfur hexafluoride (SF6).

The F-Gas regulation, initiated by the European Commission, aims to reduce the greenhouse effect in the EU from 80 to 95% (compared to 1990 levels) in the field of air conditioning.

### GWP COMPARISON BETWEEN COMMON FLUID

Refrigerant fluid	R404A	R410A	R407C	R134a	R32	R290
<b>GWP</b> (Global Warming Potential)	<b>3920</b>	<b>2088</b>	<b>1774</b>	<b>1430</b>	<b>675</b>	<b>3</b>

### EQUIPMENT DISTRIBUTOR

Keeping a register including nature and the type of equipment sold

#### The purchaser is a distributor or operator

- ✓ Name
- ✓ SIRET or SIREN
- ✓ Certificate number of capacity issued equivalent in EU

#### The purchaser is neither distributor nor operator

- ✓ Name
- ✓ SIRET (if applicable)
- ✓ Name of the operator with from which he has contracted to assembly and commissioning equipment (SIRET No. of this one + certificate number capacity or certificate equivalent issued in EU)

- ✓ Copy of the contract retained by the equipment distributor during at least 5 years (since the date acquisition of equipment)



## AIRWELL ACADEMY

PRODUCT TRAINING

JOB TRAINING

SKILLS TRAINING

For more details on trainings:  
[www.airwell-academy.fr](http://www.airwell-academy.fr)



# Airwell

*your expert...*

## CUSTOMERS

*The French expert has an international network of partners (distributors, installers...).*

*Together, you build a lasting relationship: pre-sales advice, product availability, technical sales support...*

*Partnership is an integral part of Airwell's DNA.*

## TECHNICAL SUPPORT

### LOCAL AND REMOTE TECHNICAL SUPPORT

- Specialized technicians.
- Direct contact by phone and on site if necessary for VIP customers.
- Training on all products.
- Commissioning by a Technical Station Approved by Airwell (TSA).

### CALL CENTER

- Quick and effective answers delivered by our experts.
- High availability.
- A multilingual center.
- Professionals trained continuously.
- A customer and service approach first!
- Listening and assistance until the complete customer satisfaction.



**+33 (0)1 76 21 82 95**

# DEDICATED TOOLS

## INTERNET WEBSITE

### Online order:

Airwell offers its referenced customers to order their products online via the website: [www.airwell-pro.com](http://www.airwell-pro.com)

### Documentation library:

<http://lh.airwell-res.com>



## BIM

### Airwell is “BIM Ready”!

In partnership with **Stabiplan**, Airwell announces its launch in **BIM** (Building Information Modeling) and offers its tertiary and commercial air conditioning (VRF) range in BIM format broadcast on the **MEPcontent** library.

This allows REVIT® users to integrate Airwell content for all their building projects, made in the 3D digital world.

Airwell Academy offers dedicated BIM training, including an introduction to the features of REVIT®, as well as drawings of heating/cooling networks.

[www.mepcontent.com](http://www.mepcontent.com)



# SPARE PARTS

## FOR PRODUCTS UNDER AIRWELL SUPPORT

 [sp@airwell-res.com](mailto:sp@airwell-res.com)  
[+33 \(0\)9 70 75 36 22](tel:+330970753622)

■ From Monday to Friday,  
from 9 am to 12:30 pm and from 2 to 5 pm

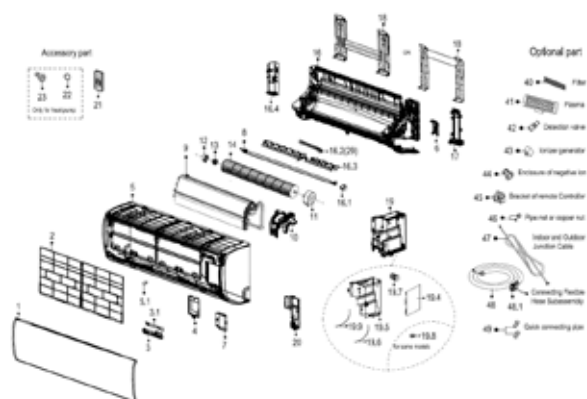

# Airwell

*your expert...*

## PRODUCTS

*With a failure rate of less than 0.04%, Airwell is committed to providing reliable products.*

*Thanks to a wide range of products, Airwell brings you particularly flexible, efficient and competitive answers, adapted to the specific characteristics of your markets.*

## CERTIFICATIONS

Airwell participates in the Eurovent certification program.

Eurovent certification confirms the performance of its air conditioning products (splits and multisplits with at least two indoor units), in accordance with european and international standards. This common platform for all manufacturers improves the integrity and accuracy of the industry's performance.



See Airwell products certified Eurovent on the site:

[www.eurovent-certification.com](http://www.eurovent-certification.com)



The performance of Airwell products meets EN-14825 (seasonal energy standard). Airwell's production sites are ISO 9001 and ISO 14001 certified and by most recognized certification bodies.

## RANGE

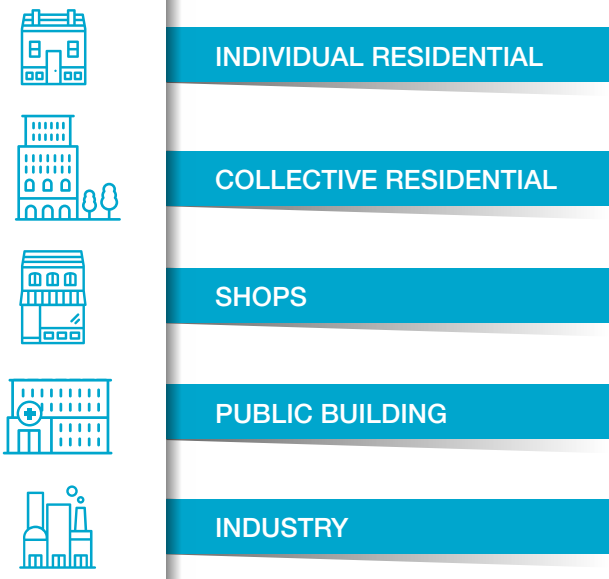

## STANDARD FEATURES ON AIRWELL AIR CONDITIONERS

- High temperature resistance (up to 60°C ambient temperature\*)
- Anti-Corrosion treatment
- Dust protection
- Electricity fluctuation protection
- Low energy consumption
- Super quiet units
- High Coefficient of Performance

\*On selected models.

## ENVIRONMENTAL APPROACH

Airwell is part of an eco-environmental approach, which includes the analysis of the life cycle of its products with the development of a Product Environmental Profile (PEP).

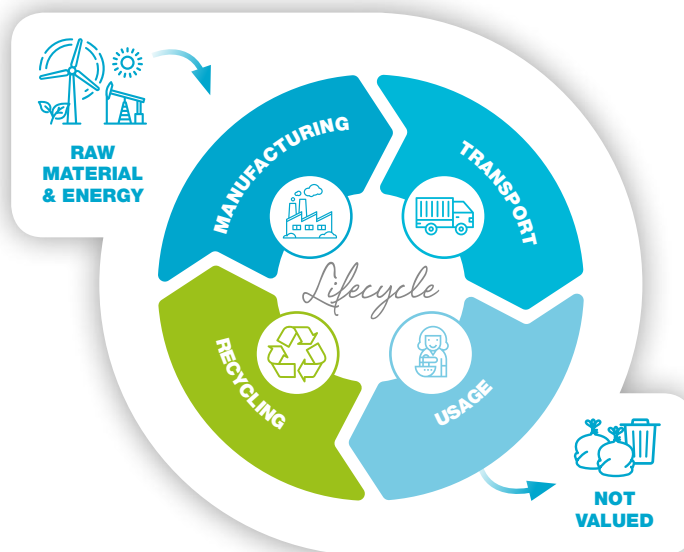

Airwell offers a range of R32 refrigerant products with low environmental impact.

This fluid offers better performance for less pollution (low Global Warming Potential).



# High wall range



MODEL NAME	Fluid type	Page	BTU/h Tons	12 1	18 1.5	24 2	30 2.5	36 3
 ON/OFF HIGH WALL	HFT FIXED SPEED T3	R410A 16			●	●	●	●
 DC INVERTER HIGH WALL	HDT INVERTER T3	R410A 18		●	●	●	●	

- **Optimum comfort** all year long
- **Purified air**
- **Energy savings**



Fixed Speed  
Cooling only

# HFT FIXED SPEED T3

## ON/OFF HIGH WALL



Tested up to 58°C  
ambient temperature



- High reliability.
- Turbo fan speed.
- Healthy air: bio filter.
- Eco mode.

### + PRODUCTS

- Golden fins.
- Refrigerant leakage detection.
- Two ways draining connection.



RC08C  
(included)



RCW8  
(optional)

### FEATURES

#### TECHNOLOGY:



R410A FLUID



4D AIRFLOW

#### AIR QUALITY / CLEAN:



NANO PHOTOCATALYTIC FILTER



AIR FILTER



GOLDEN FINES TREATMENT



AUTO CLEAN/DRY

#### USER FUNCTIONS:



I FEEL



NIGHT MODE



REFRIGERANT LEAKAGE DETECT



AUTO RESTART (MEMORY)



REMOTE CONTROL LOCK

#### INSTALLER FUNCTIONS:



ERROR CODE VIA INDOOR UNIT



SELF DIAGNOSTIC



LEFT/RIGHT DRAIN CONNECTION

### Refrigerant leakage detection alarm system

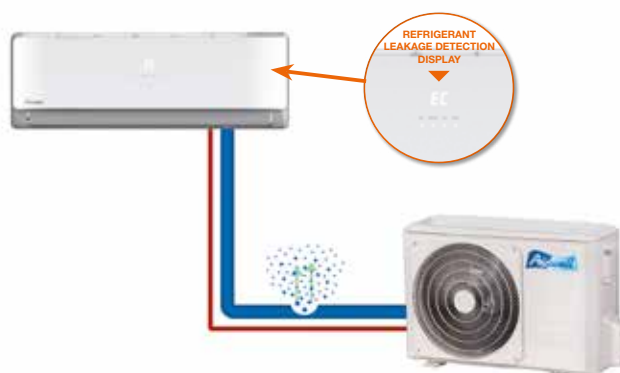

### OPTIONS

Accessory	Part number	Photo	Function
Wired single control RCW8	7ACEL1706		Mode, fan speed, timer On/Off, temperature and swing.
Test tool for high wall	7ACEL1710		Easy viewing of system parameters, failure records and parameter adjustments.
Water pump FlowatchDesign	7ACTL0518		Evacuate condensates from indoor units.



**HFT TECHNICAL DATA**

Indoor units		AW-HFT018-N11	AW-HFT024-N11	AW-HFT030-N11	AW-HFT036-N11
Outdoor units		AW-YHFT018-H11	AW-YHFT024-H11	AW-YHFT030-H11	AW-YHFT036-H11
Phase		Single phase	Single phase	Single phase	Single phase
<b>COOLING</b>					
Capacity	Tons	1.5	2.0	2.5	3
Power input	W	1526	1945	2358	2640
EER (T1)	(Btu/h)/W	11.94	11.81	11.84	11.90
EER (T3)	(Btu/h)/W	8.70	8.64	8.66	8.57
<b>INDOOR UNIT</b>					
Air flow (HS/MS/LS)	m <sup>3</sup> /h	1117/957/887	1060/947/870	1450/1280/1037	1450/1300/1050
Noise level (HS/LS)	dB(A)	47.0/38.5	46.0/41.0	49.5/39.5	49.5/39.5
Design pressure	MPa	4.3/1.5	4.5/1.5	4.5/1.5	4.5/1.5
Dimension (WxDxH)	mm	1080x226x335	1080x226x335	1259x282x362	1259x282x362
Packing (WxDxH)	mm	1155x315x415	1155x315x415	1340x380x450	1340x380x450
Net/Gross weight	Kg	14.3/18.1	14.5/18.2	21.8/27.5	22.2/28.0
Part number		<b>NC</b>	<b>NC</b>	<b>NC</b>	<b>NC</b>
<b>OUTDOOR UNIT</b>					
Phase/Tension/Frequency		1P/220-240V/60Hz			
Noise level	dB(A)	56.0	57.5	58.5	62.0
Dimension (WxDxH)	mm	845x363x702	946x410x810	946x410x810	946x410x810
Packing (WxDxH)	mm	965x395x765	1090x500x875	1090x500x875	1090x500x875
Net/Gross weight	Kg	46.2/49.5	61.8/67.8	66.3/72.1	66.9/73.1
Part number		<b>NC</b>	<b>NC</b>	<b>NC</b>	<b>NC</b>
<b>PIPE LINE</b>					
Refrigerant type	g	R410A/1400	R410A/2000	R410A/2400	R410A/2500
Liquid side/Gas side (Ø)	mm (inches)	6.35/12.7 (1/4"/1/2")	9.52/15.9 (3/8"/5/8")	9.52/15.9 (3/8"/5/8")	9.52/19 (3/8"/3/4")
Max. refrigerant pipe length	m	25	25	25	25
Max. difference in level	m	10	10	10	10
Connection wiring	mm <sup>2</sup>	2.5x3	2.5x4	1.0x4	1.0x4
<b>OPERATING LIMITS</b>					
Indoor room temperature	°C	17-32	17-32	17-32	17-32
Outdoor room temperature	°C	18-52	18-52	18-52	18-52
<b>OTHER CHARACTERISTICS</b>					
Application area (cooling standard)	m <sup>2</sup>	24-35	31-45	37-55	41-61

DC Inverter  
Cooling only

# HDT INVERTER T3

## DC INVERTER HIGH WALL



- Premium energy efficient product.
- Cooling and heating mode.
- Smart Airwell, WiFi integrated.
- Super quiet.
- Healthy air: bio filter.

Tested up to 67°C  
ambient temperature

### + PRODUCTS

- Golden fins.
- Intelligent unit.
- 12 grades indoor fan speed.



RC08C  
(included)



RCW22  
(optional)

Longer product lifetime: golden fins exchanger  
and anti-corrosion treatment on PCB.

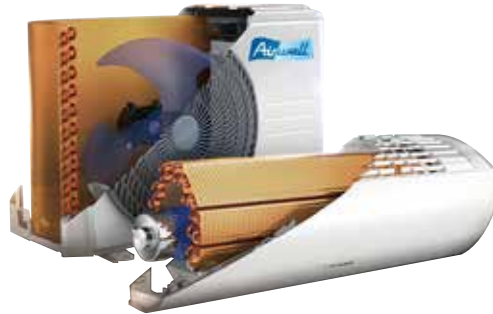

### FEATURES

#### TECHNOLOGY:

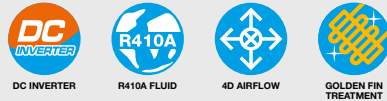

#### AIR QUALITY/CLEAN:



#### USER FUNCTIONS:

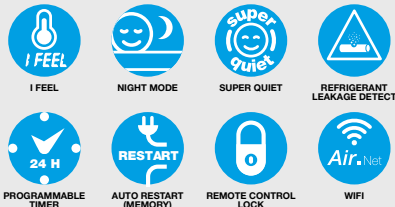

#### INSTALLER FUNCTIONS:



### OPTIONS

Accessory	Part number	Photo	Function
Wired single control RCW22	7ACEL1778		Weekly timer, mode, fan speed, timer On/Off, "I Feel" function, temperature.
Dry contact On/Off	7ACEL1788		External control of air conditioner.
Test tool for high wall	7ACEL1710		Easy viewing of system parameters, failure records and parameter adjustments.
Water pump FlowwatchDesign	7ACTL0518		Evacuate condensates from indoor units.

### HDT TECHNICAL DATA

Indoor units		AW-HDT012-N15	AW-HDT018-N15	AW-HDT022-N15	AW-HDT027-N15
Outdoor units		AW-YHDT012-H15	AW-YHDT018-H15	AW-YHDT022-H15	AW-YHDT027-H15
Phase		Single phase	Single phase	Single phase	Single phase
<b>COOLING</b>					
Capacity	Tons	1.0	1.5	2.0	2.5
Power input	W	890	1272	1553	2139
EER (T1)	(Btu/h)/W	13.41	12.99	13.63	12.42
EER (T3)	(Btu/h)/W	9.66	9.83	9.60	8.90
<b>INDOOR UNIT</b>					
Air flow (Turbo/HS/MS/LS)	m <sup>3</sup> /h	680/605/480/390	1250/1190/910/850	1250/1150/920/810	1420/1300/1110/980
Noise level (Turbo/HS/MS/LS/Breeze)	dB(A)	42/42/37/33/25	50/49/42/41/32	52/50/45/43/37	51/50/46/43/38
Design pressure	MPa	4.8/1.5	4.8/1.5	4.8/1.5	4.8/1.5
Dimension (WxDxH)	mm	802x189x297	1080x226x335	1080x226x335	1259x282x362
Packing (WxDxH)	mm	875x285x375	1155x315x415	1155x315x415	1340x450x380
Net/Gross weight	kg	8.7/11.1	13.5/17.1	13.8/17.4	20/25.9
<b>Part number</b>		<b>7SP023120</b>	<b>7SP023121</b>	<b>7SP023122</b>	<b>7SP023123</b>
<b>OUTDOOR UNIT</b>					
Phase/Tension/Frequency		1P/220-240V/50-60Hz			
Noise level	dB(A)	55	59	61	61
Dimension (WxDxH)	mm	800x333x554	845x363x702	946x410x810	946x410x810
Packing (WxDxH)	mm	920x390x615	965x395x765	1090x500x875	1090x500x865
Net/Gross weight	kg	37.3/39.9	41.4/44.6	59.6/65.4	64.1/69.3
<b>Part number</b>		<b>7SP063025</b>	<b>7SP063026</b>	<b>7SP063027</b>	<b>7SP063028</b>
<b>PIPE LINE</b>					
Refrigerant/GWP	g	R410A/2088	R410A/2088	R410A/2088	R410A/2088
Charge	g	1250	1680	2300	2730
Liquid side/Gas side (Ø)	mm (inches)	6.35/12.7 (1/4"/1/2")	6.35/12.7 (1/4"/1/2")	9.52/15.9 (3/8"/5/8")	9.52/19 (3/8"/3/4")
Max. refrigerant pipe length	m	25	30	30	50
Max. difference in level	m	10	20	20	25
Connection wiring	mm <sup>2</sup>	1.5x4 (Optional)	1.5x4 (Optional)	1.5x4 (Optional)	1.5x4 (Optional)
<b>OPERATING LIMITS</b>					
Indoor room temperature (cooling/heating)	°C	17-32/0-30	17-32/0-30	17-32/0-30	17-32/0-30
Outdoor room temperature (cooling/heating)	°C	0-60/-15-30	0-60/-15-30	0-60/-15-30	0-60/-15-30
<b>OTHER CHARACTERISTICS</b>					
Application area	m <sup>2</sup>	16-23	24-35	29-43	36-53

# Ducted range



MODEL NAME	Fluid type	Page	kBTU/h kW	18 1.5	24 2	36 3	48 4	60 5
 DC INVERTER DUCTED T3	DDT INVERTER R410A T3	22		●	●	●	●	●

→ The future of  
air conditioning?  
**The invisibility**

DC Inverter  
Cooling only

# DDT INVERTER T3

## DUCTED T3



Tested up to 60°C  
ambient temperature

- Comfort "I Feel": temperature sensor in the remote control RC08C.
- Designed for easy maintenance and installation.
- Reduced energy consumption using the heating only mode.
- Port for ventilation fan: increase static pressure or useful for adjacent room.

### + PRODUCTS

- Golden fins.
- Dry contact adaptor.
- External static pressure until 160 Pa.



RCW11 (included) RC08C (optional) RCW20 (optional)

### FEATURES

#### TECHNOLOGY:



#### AIR QUALITY/CLEAN:



#### USER FUNCTIONS:



#### INSTALLER FUNCTIONS:

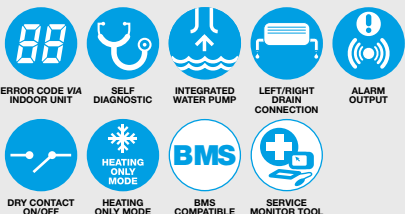

### SUPER QUIET



### OPTIONS

Accessory	Part number	Photo	Function/Description
Wireless controller RC08C	7ACEL1740		Timer, eco mode, "Follow me" option, swing, technician mode, heating only mode.
Wired single control RCW20 + adaptor	7ACEL1775 + 7ACEL1776		<b>Zone control</b> , mode, fan speed, timer On/Off, "I Feel" function, temperature. One adaptor by unit is required (order separately).
Central controller RCW21	7ACEL1777		<b>Central controller</b> . Controls up to 64 indoor units with individual setting failure codes indication, On/Off dry contact, last operation memory.
BMS gateway	7ACEL1708		Maximum 1024 units could be connected (16 gateways).
Test tool	7ACEL1710		Easy viewing of system parameters, failure records and parameter adjustments.
Insulated air duct plenum	7ACVF0136		3 ducts DN160. For DDM 12-18.
	7ACVF0137		3 ducts DN 160. For DDM 24.
	7ACVF0138		3 ducts DN 160. For DDM 36.
	7ACVF0139		3 ducts DN 160. For DDM 48-60.

## DDT TECHNICAL DATA

Indoor units		AW-DDT018-N15	AW-DDT025-N15	AW-DDT036-N15	AW-DDT048-N15	AW-DDT055-N1
Outdoor units		AW-YDDT018-H15	AW-YDDT025-H15	AW-YDDT036-H15	AW-YDDT048-H16	AW-YDDT055-H16
Phase		Single phase	Single phase	Single phase	Three phase	Three phase
<b>COOLING</b>						
Capacity	Tons	1.5	2.0	3.0	4.0	5.0
Power input	W	1510	2140	2850	1425/ph	1540/ph
EER (T1)	(Btu/h)/W	11.98	11.84	11.91	11.81	11.81
EER (T3)	(Btu/h)/W	8.77	8.50	8.59	8.56	8.56
<b>INDOOR UNIT</b>						
Power supply		1P/220-240V/50-60Hz				
ESP Rated	Pa	25	25	37	50	50
ESP Range	Pa	0-80	0-100	0-120	0-160	0-160
Indoor noise level (HS/MS/LS) (under rated ESP)	dB(A)	46/43/39	42/40/36	50/48/43	49/47/44	51/48/45
Dimension (WxDxH)	mm	880x674x210	1100x774x249	1200x874x300	1200x625x380	1400x858x440
Packing (WxDxH)	mm	1070x725x270	1305x805x305	1405x915x355	1485x675x450	1605x910x505
Net/Gross weight	kg	25.2/30.9	30.2/37.4	42.8/51	55.9/63.7	72.7/84.3
Controller		Wired control	Wired control	Wired control	Wired control	Wired control
Operation temperature	°C	17-30	17-30	17-30	17-30	17-30
Qty' per 20'/40'/40'HQ		120/264/297	77/161/184	62/130/149	59/124/125	35/72/86
<b>Part number</b>		<b>7SP032200</b>	<b>7SP032201</b>	<b>7SP032202</b>	<b>7SP032203</b>	<b>7SP032204</b>
<b>OUTDOOR UNIT</b>						
Phase/Tension/Frequency		1P/220-240V/50-60Hz			3P/380-415V/50-60Hz	
Outdoor noise level (sound pressure)	dB(A)	59	59	61	65	65
Throttle type		Throttle valve	Throttle valve	Throttle valve	Throttle valve	Throttle valve
Design pressure	MPa	4.8/1.5	4.8/1.5	4.8/1.5	4.8/1.5	4.8/1.5
Dimension (WxDxH)	mm	845x363x702	946x410x810	946x410x810	952x415x1333	952x415x1333
Packing (WxDxH)	mm	965x395x765	1090x500x875	1090x500x875	1095x495x1480	1095x495x1480
Net/Gross weight	kg	41.2/44.7	55.3/61.7	66.5/71.9	94/107.2	97.3/110.3
Qty' per 20'/40'/40'HQ		102/216/216	44/96/144	44/96/144	22/48/48	22/48/48
<b>Part number</b>		<b>7SP063010</b>	<b>7SP063011</b>	<b>7SP063012</b>	<b>7SP063013</b>	<b>7SP063014</b>
<b>PIPE LINE</b>						
Type		R410A	R410A	R410A	R410A	R410A
Charged volume	kg	1.75	2.12	3.2	4.2	4.4
Liquid side/Gas side (Ø)	mm (inches)	6.35/12.7 (1/4"/1/2")	9.52/15.9 (3/8"/5/8")	9.52/19 (3/8"/3/4")	9.52/19 (3/8"/3/4")	9.52/22 (3/8"/7/8")
Max. pipe length	m	25	25	30	50	50
Max. difference in level	m	15	15	20	30	30
<b>AMBIENT TEMPERATURE</b>						
Cooling	°C	18-60	18-60	18-60	18-60	18-60
Heating	°C	-31	-31	-31	-31	-31

# VRF Range

## Outdoor groups

MODEL NAME		Fluid type	Page	Capacity (HP)	Cooling power (kW)	Heating power (kW)
FLOWLOGIC III T3 SECTION	YDV250HT	R410A	32	8	23.2	27
	YDV280HT			10	25.2	33.5
	YDV335HT			12	28.5	37.8
	YDV400HT			14	32.8	45
	YDV450HT			16	39.6	50
	YDV504HT			18	42.8	58.5
	YDV560HT			20	44.8	63
WATER FLOWLOGIC	YWC220	R410A	36	22.4	8	25.0
	YWC280			28.0	10	31.5
	YWC335			33.5	12	37.5





## RANGE TABLE MINI FLOWLOGIC II & FLOWLOGIC III

Capacity (HP)	Cooling power (kW)	Heating power (kW)	OUTDOOR UNITS	INDOOR UNITS	
			Combinations Mini FlowLogic II & FlowLogic III	Maximum indoor units connectable	Range cooling power connectable* (kW)
10	28	31.5	1 X YDV280	16 or 20	14 - 36
14	40	45	1 X YDV400	29	20 - 52
16	45	50	1 X YDV450	33	22.5 - 58.5
18	50.4	56.5	1 X YDV504	37	25.2 - 65.5
20	56	63	1 X YDV560	41	28 - 72
24	68	76.5	1 X YDV680	49	34 - 88
28	80	87.5	2 X YDV400	58	40 - 104
30	85	95	1 X YDV400 + 1 X YDV450	62	43 - 110.5
32	90	100	1 X YDV400 + 1 X YDV504	64	45 - 117
34	96	108	1 X YDV450 + 1 X YDV560	64	48 - 124.5
36	101	113	1 X YDV450 + 1 X YDV560	64	51 - 131
38	108	119	1 X YDV504 + 1 X YDV560	64	54 - 140
40	113	126.5	2 X YDV560	64	57 - 146.5
44	123.5	137.5	1 X YDV560 + 1 X YDV680	64	62 - 160.5
48	135	150	2 X YDV680	64	68 - 175.5
50	140.8	158	1 X YDV400 + 2 X YDV504	64	70.4 - 183.04
52	146	163	2 X YDV450 + 1 X YDV560	64	73 - 189.8
54	151.4	169.5	1 X YDV450 + 1 X YDV504 + 1 X YDV560	64	75.7 - 196.82
56	157	176	2 X YDV450 + 1 X YDV560	64	78.5 - 204.1
58	162.4	182.5	1 X YDV504 + 2 X YDV560	64	81.2 - 211.12
60	168	189	3 X YDV560	64	84 - 218.4
64	180	199	2 X YDV560 + 1 X YDV680	64	90 - 234
68	192	209	1 X YDV560 + 2 X YDV680	64	96 - 249.6
72	204	219	3 X YDV680	64	102 - 265.2

\* Indoor total capacity can be 50% - 130% of outdoor capacity.

# VRF Range Indoor units

MODEL NAME			Fluid type	Page
HIGH WALL	HBV		R410A	38
CASSETTE 600X600	CBV		R410A	39
CASSETTE 900X900	CCV		R410A	40
360° CASSETTE	 CFV		R410A	41
FLOOR CEILING	FAV		R410A	42
DUCTED LOW STATIC PRESSURE	 DDV		R410A	43
DUCTED MEDIUM STATIC PRESSURE	 DBV		R410A	44
DUCTED HIGH STATIC PRESSURE	DCV		R410A	45
CONSOLE	 EAV		R410A	46
AHU CONNECTION KIT				48

Capacity (kBtu/h)	5	7	9	12	16	18	24	28	30	38	48	60	72	96	192
Capacity (HP)	0.5	0.75	1.25	1.5	1.75	2.25	3	3.5	3.75	4.75	6	7	9	12	24
Cooling (kW)	1.5	2.2	2.8	3.6	4.5	5.6	7.1	8	9	11.2	14	16	22.6	28	56
Heating (kW)	1.7	2.5	3.2	4	5	6.3	8	9	10	12.5	16	18	25	31.5	63

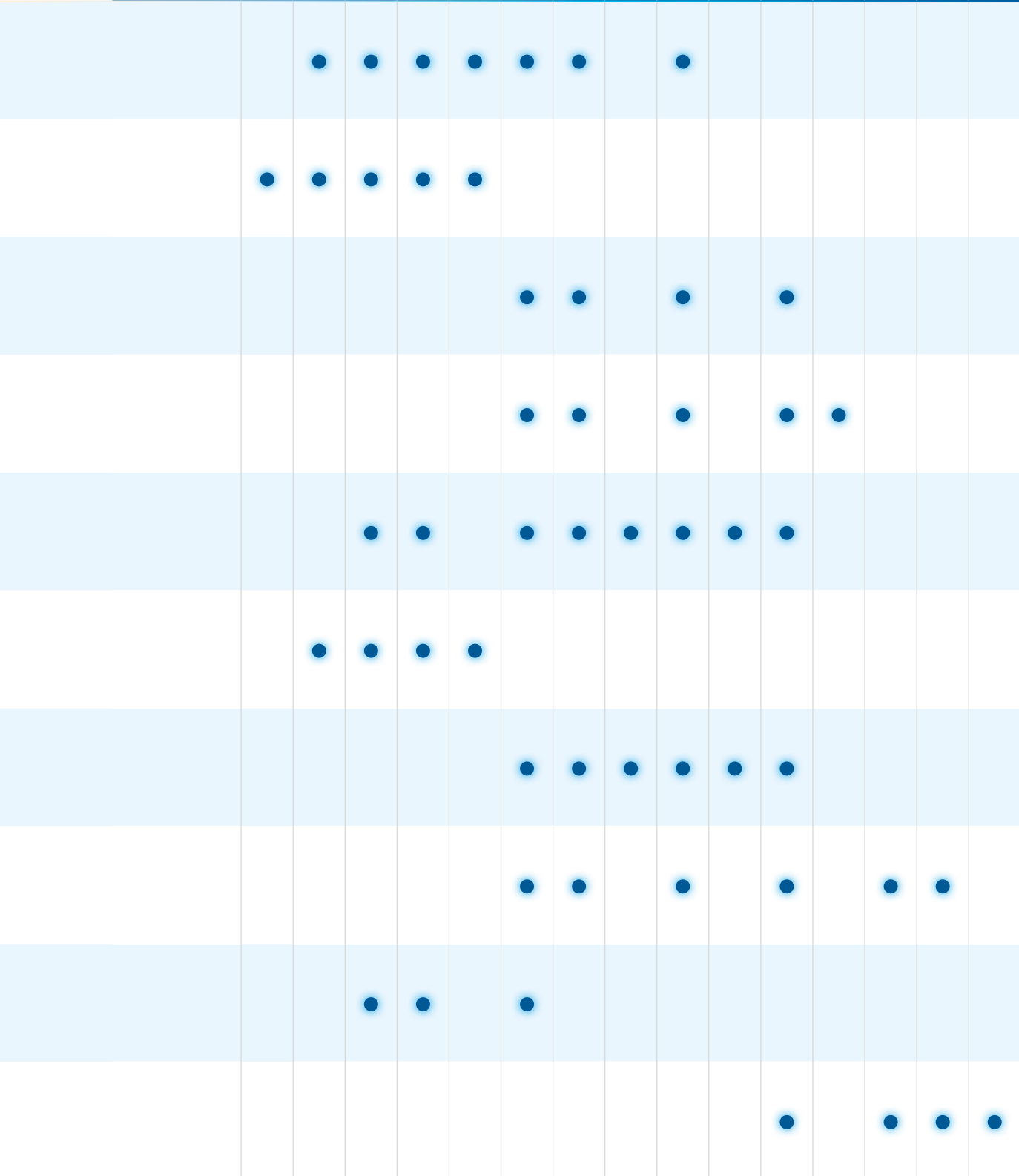

# Why choosing a VRF system?



## ■ One system for multiple applications



Shopping centers



Villas



Hostels



Offices

## ■ Extrem versatility

- All seasons
- Immediate change mode (heating/cooling)
- Extendable system
- Any indoor unit
- Anti-corrosion treatment on demand

**Blygold®**



HIGH WALL HBV



CASSETTE 600x600 CBV



CASSETTE 900x900 CCV



360° CASSETTE CFV



FLOOR CEILING FAV



DUCTED LOW STATIC PRESSURE DDV



DUCTED MEDIUM STATIC PRESSURE DBV



DUCTED HIGH STATIC PRESSURE DCV



CONSOLE EAV



AHU CONNECTION KIT

## ■ Easy installation

- Professional selection software
- Easy setup (piping, electricity, regulation...)
- Ideal solution for refurbishment (easy installation also in inhabited places)

## Why choosing an Airwell VRF system?

- Wide range of power: from 3 to 72 HP (from 8 to 204 kW)
- Silent system
- Compact solution: small footprint
- High performance: COP until 4.5
- Certified Eurovent 

## Performant system

### USE HIGH EFFICIENCY DC INVERTER SCROLL COMPRESSOR, HIGH EFFICACITY, LOW NOISE

The highly efficient Scroll compressor is equipped with a “Framen Compliance Mechanism” that allows movement in the axial direction of the frame supporting the cradle Scroll. This greatly reduces both leakage and friction loss, ensuring very high efficiency throughout the speed range.



### HIGH EFFICIENCY DC FAN MOTOR

The speed of wide range DC fan motor can be adjusted from 0 to 1000 tr/min.

Compared to conventional AC motors, a DC fan motor offers greater operating efficiency, especially during low speed rotation. The efficiency could be 90%.



### HEAT EXCHANGER ADOPTS THE SUBCOOLING TECHNOLOGY: HIGH EFFICIENCY

- The system is cooled with little refrigerant.
- Improve subcooling degree of refrigerant.
- Avoid energy loss due to refrigerant flash evaporating when it goes through PMV.
- W-model Ø8 innergrooved tube.
- Hydrophilic aluminium coil fin, it will increase efficiency of heat exchange by 5%.

**Increase the efficiency of system**



- **Increase cooling power by 6%.**
- **Reduce refrigerant circulation amounts.**

### PRECISE CONTROL

PID control adjusts the output of compressor and the open degree of EEV, balances the indoor refrigerant flow, realizes the linear output, creates a comfortable environment. The temperature can be controlled precisely.

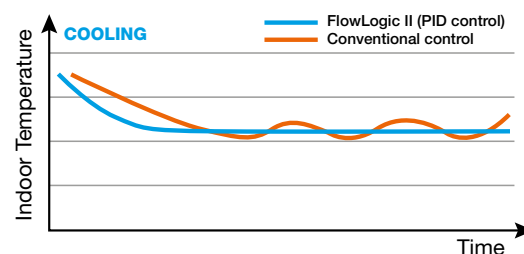



### + PRODUCTS

- COP can reach 4.45.
- Compact (0.97 m<sup>2</sup> footprint).
- Large capacity range (single and combination).
- DC Inverter compressor and ventilator.



### FEATURES

#### TECHNOLOGY:



- Capacity range from 10 HP to 72 HP.
- Capacity range until 24 HP with only one unit.
- Designed for all commercial uses.
- Minimum outdoor temperature for heating mode operation -23°C.
- Minimum outdoor temperature for cooling mode operation -5°C.
- Refrigerant simple pipe length up to 1000 m.
- Capacity ratio 50-130%.
- Certified Eurovent.

### TUBING ACCESSORIES

Accessory	Part number	Code	Photo	Function	Comments
Gather pipe kit for 2 outdoor groups	7ACFHH013	TBS20		Refrigerant gathering	For 2 outdoor groups
Gather pipe kit for 3 outdoor groups	7ACFHH014	TBS30		Refrigerant gathering	For 3 outdoor groups
Manifold pipe (gas + liquid)	7ACFHH001	TAU335		Refrigerant gathering	33.5 kW > Total indoor units power
	7ACFHH002	TAU506		Refrigerant gathering	33.5 kW ≤ Total indoor units power < 50.6 kW
	7ACFHH003	TAU730		Refrigerant gathering	50.6 kW ≤ Total indoor units power < 73 kW
	7ACFHH004	TAU1350		Refrigerant gathering	73 kW ≤ Total indoor units power < 135 kW
	7ACFHH015	TAU2040		Refrigerant gathering	135 kW ≤ Total indoor units power

**HIGH MODULARITY: LONG PIPE LENGTH, HIGH HEIGHT DROP**

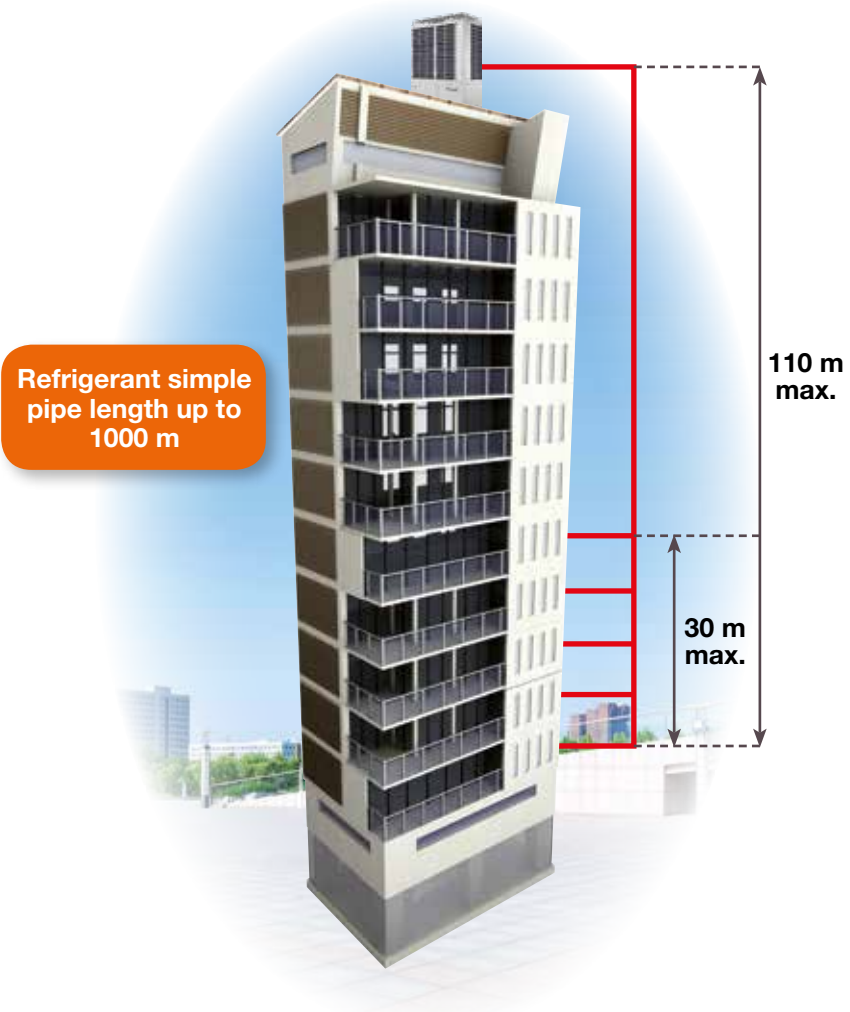

- Floor area optimized for all the product range (same foot print for all modules: 0.97 m<sup>2</sup>)
- One of the smallest footprint on market.

- Full DC inverter
- 2 x Full DC Inverter



→ 0.97 m<sup>2</sup>



- High static pressure outdoor unit:  
**82 Pa**, long air duct



**Hidden solution:**  
Installation of  
outdoor unit in a  
technical room

- Wide operation range

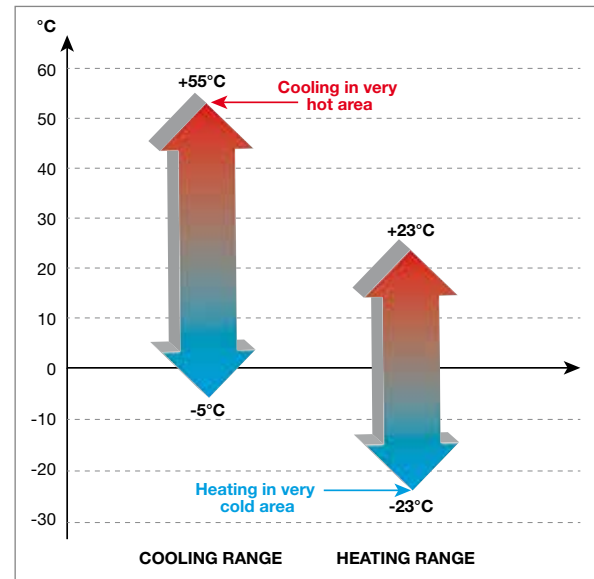

→ **Specific design:**

- Double EEV
- Two-piece condenser
- Independent electrical box

→ **Reliability/Maintenance:**

- Compressor double protection: Two pressure sensors
- Double oil temperature sensor
- Large volume gas-liquid separator (26L) + liquid storage tank (10L)
- Two floor structure (no air bypass during maintenance): efficient measures

→ **Fan:**

- Optimized fan to reduce air vibration
- DC fan to optimize efficiency
- 82 Pa static pressure

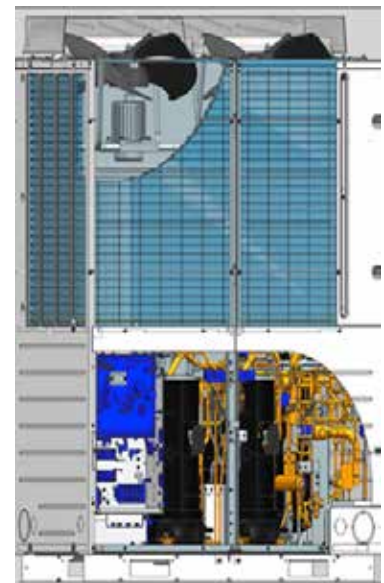

■ **Specific oil return**

- Magnetic valve
- If the compressor operate at low frequency, oil return is only with capillary.
- If the compressor operate at higher frequency, PCB control magnetic valve to improve oil return.

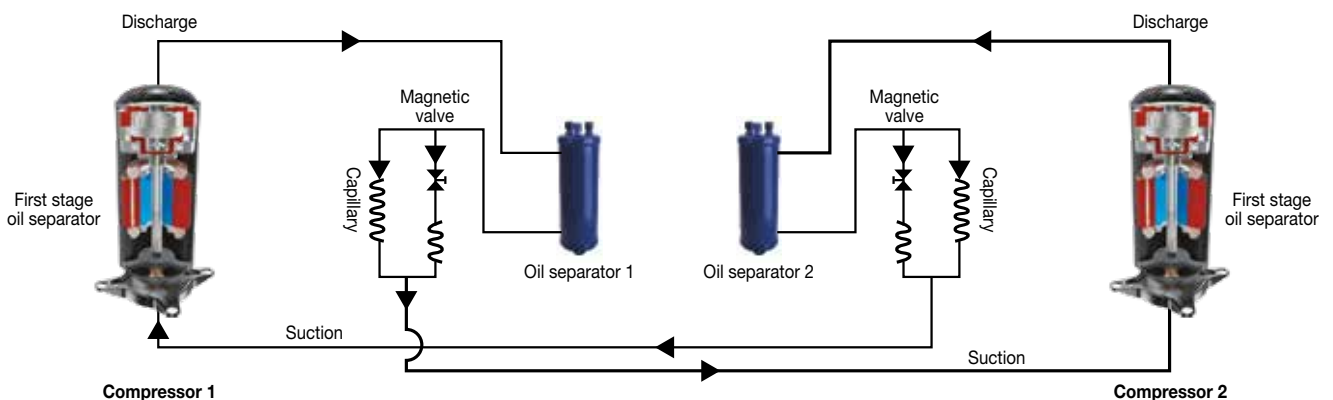





## FLOWLOGIC III T3 TECHNICAL DATA

Outdoor units	AW-YDV250HT-H16	AW-YDV280HT-H16	AW-YDV335HT-H16	AW-YDV400HT-H16	AW-YDV450HT-H16	AW-YDV504HT-H16	AW-YDV560HT-H16
Phase	Three phases	Three phases	Three phases	Three phases	Three phases	Three phases	Three phases
Part number	7SP14H050	7SP14H051	7SP14H052	7SP14H053	7SP14H054	7SP14H055	7SP14H056



### RATED POWER

	kW	23.2	25.2	28.5	32.8	39.6	42.8	44.8
Cooling	kW	23.2	25.2	28.5	32.8	39.6	42.8	44.8
Heating	kW	27	33.5	37.8	45	50	58.5	63

### ELECTRICAL PARAMETERS

Phase/Tension/Frequency		3P/380-400V/50-60Hz/N						
Cooling rated power input	kW	7.02	8.66	9.76	11.45	13.26	15.25	16.96
Heating rated power input	kW	5.85	7.32	8.70	10.57	11.95	14.05	15.40
EER/COP		4.20/4.62	3.85/4.58	3.93/4.34	3.91/4.26	3.86/4.18	3.80/4.16	3.68/4.09
Max. current - Cooling	A	25.10	28.40	32.37	36.80	54.53	56.60	60.50
Max. current - Heating	A	19.00	25.20	27.90	33.26	38.00	42.30	47.40

### PERFORMANCE

	m³/h	15000	15000	15000	15600	16200	16200	16200
Airflow (HS)	m³/h	15000	15000	15000	15600	16200	16200	16200
Sound pressure level (HS)	dB(A)	57	57	57	58	59	60	61
Sound power level (HS)	dB(A)	73	73	73	74	76	77	78

### INSTALLATION

	mm	1350x720x1690	1350x720x1690	1350x720x1690	1350x720x1690	1350x720x2048	1350x720x2048	1350x720x2048
External dimensions (WxHxD)	mm	1350x720x1690	1350x720x1690	1350x720x1690	1350x720x1690	1350x720x2048	1350x720x2048	1350x720x2048
Net weight/Gross weight	kg	269/305	269/305	275/311	323/359	380/426	380/426	380/426
Compressor type		Scroll DC Inverter	Scroll DC Inverter	Scroll DC Inverter	Scroll DC Inverter	Scroll DC Inverter	Scroll DC Inverter	Scroll DC Inverter
External static pressure	Pa	82	82	82	82	82	82	82
Liquid pipe diameter	inches	9.52	12.7	12.7	12.7	15.88	15.88	15.88
Suction pipe diameter	inches	22.22	25.4	28.58	28.58	28.58	28.58	28.58
Max. pipe length	m	1000	1000	1000	1000	1000	1000	1000
Max. height between indoor and outdoor units*	m	50/40	50/40	50/40	50/40	50/40	50/40	50/40
Max. height between indoor units	m	18	18	18	18	18	18	18
Maximum indoor units connectable	quantity	13	16	20	24	27	30	33

### OPERATING LIMITS

Cooling	°C	-5°/55° Dry bulb						
Heating	°C	-23°/18° Wet bulb						

### PIPE LINE

Refrigerant / GWP		R410A	R410A	R410A	R410A	R410A	R410A	R410A
Charge	kg	9.7	9.7	10	10	10	10	10

\* 30 m if the outdoor unit is above indoor unit, 20 m if the outdoor unit is below indoor unit.

TECHNICAL DATA FOR TWO COMBINATIONS

Outdoor units	AW-YDV615HT-H16	AW-YDV680HT-H16	AW-YDV735HT-H16	AW-YDV800HT-H16	AW-YDV850HT-H16	AW-YDV904HT-H16	AW-YDV950HT-H16	AW-YDV1010HT-H16	AW-YDV1064HT-H16	AW-YDV1120HT-H16
Phase	Three phases	Three phases	Three phases	Three phases	Three phases	Three phases	Three phases	Three phases	Three phases	Three phases
Part number	AW-YDV280HT-H16	AW-YDV280HT-H16	AW-YDV335HT-H16	AW-YDV400HT-H16	AW-YDV400HT-H16	AW-YDV400HT-H16	AW-YDV450HT-H16	AW-YDV504HT-H16	AW-YDV504HT-H16	AW-YDV560HT-H16
	AW-YDV280HT-H16	AW-YDV400HT-H16	AW-YDV400HT-H16	AW-YDV400HT-H16	AW-YDV400HT-H16	AW-YDV450HT-H16	AW-YDV504HT-H16	AW-YDV504HT-H16	AW-YDV504HT-H16	AW-YDV560HT-H16



RATED POWER

	kW	53.7	58.0	61.3	65.6	72.4	75.6	82.4	85.6	87.6	89.6
Cooling	kW	53.7	58.0	61.3	65.6	72.4	75.6	82.4	85.6	87.6	89.6
Heating	kW	71.3	78.5	82.8	90	95	103.5	108.5	117	121.5	126

ELECTRICAL PARAMETERS

Phase/Tension/Frequency	3P/380-400V/50-60Hz/N										
Cooling rated power input	kW	18.42	20.11	21.21	22.90	24.71	26.70	28.51	30.50	32.21	33.92
Heating rated power input	kW	16.02	17.89	19.27	21.14	22.52	24.62	26.00	28.10	29.45	30.80
EER/COP		3.89/4.45	3.89/4.39	3.92/4.30	3.91/4.26	3.88/4.22	3.85/4.20	3.83/4.17	3.80/4.16	3.74/4.13	3.68/4.09
Max. current - Cooling	A	60.77	65.20	69.17	73.60	91.33	93.40	111.13	113.20	117.10	121.00
Max. current - Heating	A	53.10	58.46	61.16	66.52	71.26	75.56	80.30	84.60	89.70	94.80

PERFORMANCE

Airflow (HS)	m³/h	30000	30600	30600	31200	31480	31480	32400	32400	32400	32400
Sound pressure level (HS)	dB(A)	60	60.5	60.5	61	61.5	62	62.5	63	63.5	65
Sound power level (HS)	dB(A)	77	78	78	78	79	79	80	80	81	83

INSTALLATION

External dimensions (WxHxD)	mm	(1350x720x1690) *2	(1350x720x1690) *2	(1350x720x1690) *2	1350x720x1690 +1350x720x2048	1350x720x1690 +1350x720x2048	1350x720x1690 +1350x720x2048	(1350x720x2048) *2	(1350x720x2048) *2	(1350x720x2048) *2	(1350x720x2048) *2
Net weight/Gross weight	kg	269/305 + 275/311	269/305 + 323/359	275/311 + 323/359	323/359 + 323/359	323/359 + 380/426	323/359 + 380/426	380/426 + 380/426	380/426 + 380/426	380/426 + 380/426	380/426 + 380/426
Compressor type		Scroll DC Inverter	Scroll DC Inverter	Scroll DC Inverter	Scroll DC Inverter	Scroll DC Inverter	Scroll DC Inverter	Scroll DC Inverter	Scroll DC Inverter	Scroll DC Inverter	Scroll DC Inverter
External static pressure	Pa	82	82	82	82	82	82	82	82	82	82
Liquid pipe diameter	inches	19.05	19.05	19.05	19.05	19.05	19.05	19.05	19.05	19.05	19.05
Suction pipe diameter	inches	31.8	31.8	31.8	31.8	38.1	38.1	38.1	38.1	38.1	38.1
Max. pipe length	m	1000	1000	1000	1000	1000	1000	1000	1000	1000	1000
Max. height between indoor and outdoor units*	m	50/40	50/40	50/40	50/40	50/40	50/40	50/40	50/40	50/40	50/40
Max. height between indoor units	m	18	18	18	18	18	18	18	18	18	18
Maximum indoor units connectable	quantity	36	40	43	46	50	53	57	60	64	64

OPERATING LIMITS

Cooling	°C	-5°/55° Dry bulb									
Heating	°C	-23°/18° Wet bulb									

PIPE LINE

Refrigerant / GWP		R410A	R410A	R410A	R410A	R410A	R410A	R410A	R410A	R410A	R410A
Charge	kg	9.7+9.7	9.7+10	10+10	10+10	10+10	10+10	10+10	10+10	10+10	10+10

TECHNICAL DATA FOR THREE COMBINATIONS

Outdoor units	AW-YDV 1200HT- H16	AW-YDV 1250HT- H16	AW-YDV 1300HT- H16	AW-YDV 1350HT- H16	AW-YDV 1408HT- H16	AW-YDV 1458HT- H16	AW-YDV 1512HT- H16	AW-YDV 1568HT- H16	AW-YDV 1624HT- H16	AW-YDV 1680HT- H16
Phase	Three phases	Three phases	Three phases	Three phases	Three phases	Three phases	Three phases	Three phases	Three phases	Three phases
Part number	AW-YDV 400HT- H16	AW-YDV 400HT- H16	AW-YDV 400HT- H16	AW-YDV 400HT- H16	AW-YDV 400HT- H16	AW-YDV 450HT- H16	AW-YDV 504HT- H16	AW-YDV 504HT- H16	AW-YDV 504HT- H16	AW-YDV 560HT- H16
	AW-YDV 400HT- H16	AW-YDV 400HT- H16	AW-YDV 400HT- H16	AW-YDV 450HT- H16	AW-YDV 504HT- H16	AW-YDV 504HT- H16	AW-YDV 504HT- H16	AW-YDV 504HT- H16	AW-YDV 560HT- H16	AW-YDV 560HT- H16
	AW-YDV 400HT- H16	AW-YDV 450HT- H16	AW-YDV 504HT- H16	AW-YDV 504HT- H16	AW-YDV 504HT- H16	AW-YDV 504HT- H16	AW-YDV 504HT- H16	AW-YDV 560HT- H16	AW-YDV 560HT- H16	AW-YDV 560HT- H16



**RATED POWER**

	kW	98.4	105.2	108.4	115.2	118.4	125.2	128.4	130.4	132.4	134.4
Cooling	kW	98.4	105.2	108.4	115.2	118.4	125.2	128.4	130.4	132.4	134.4
Heating	kW	135	140	148.5	153.5	162	167	175.5	180	184.5	189

**ELECTRICAL PARAMETERS**

Phase/Tension/Frequency	3P/380-400V/50-60Hz/N										
Cooling rated power input	kW	34.35	37.07	38.53	39.96	41.95	43.76	45.75	47.46	49.17	50.88
Heating rated power input	kW	31.71	33.29	33.91	36.57	38.67	40.05	42.15	43.50	44.85	46.20
EER/COP		3.91/4.26	3.89/4.21	3.92/4.38	3.85/4.20	3.83/4.19	3.82/4.17	3.80/4.16	3.76/4.14	3.72/4.11	3.68/4.09
Max. current - Cooling	A	57.99	62.58	65.05	67.46	70.82	73.88	77.24	80.12	83.01	85.90
Max. current - Heating	A	99.77	105.86	111.56	113.56	117.86	122.60	126.90	132.00	137.10	142.20

**PERFORMANCE**

	m³/h	46800	46800	46800	48000	48000	48000	48000	48600	48600	48600
Airflow (HS)	m³/h	46800	46800	46800	48000	48000	48000	48000	48600	48600	48600
Sound pressure level (HS)	dB(A)	63	63	63.5	64	64	64.5	65	65	65.5	66
Sound power level (HS)	dB(A)	81	81	82	82	82	83	83	83	84	84

**INSTALLATION**

External dimensions (WxHxD)	mm	1350x720x2048 + (1350x720x1690)*3	1350x720x2048 + (1350x720x1690)*2	1350x720x2048 + (1350x720x1690)*2	(1350x720x2048)*2 + 1350x720x1690	(1350x720x2048)*2 + 1350x720x1690	(1350x720x2048)*3	(1350x720x2048)*3	(1350x720x2048)*3	(1350x720x2048)*3	(1350x720x2048)*3
Net weight/Gross weight	kg	323/359 + 323/359 + 323/359	323/359 + 323/359 + 380/426	323/359 + 323/359 + 380/426	323/359 + 380/426 + 380/426	323/359 + 380/426 + 380/426	380/426 + 380/426 + 380/426	380/426 + 380/426 + 380/426	380/426 + 380/426 + 380/426	380/426 + 380/426 + 380/426	380/426 + 380/426 + 380/426
Compressor type		Scroll DC Inverter	Scroll DC Inverter	Scroll DC Inverter	Scroll DC Inverter	Scroll DC Inverter	Scroll DC Inverter	Scroll DC Inverter	Scroll DC Inverter	Scroll DC Inverter	Scroll DC Inverter
External static pressure	Pa	82	82	82	82	82	82	82	82	82	82
Liquid pipe diameter	inches	19.05	19.05	19.05	19.05	19.05	19.05	19.05	22.22	22.22	22.22
Suction pipe diameter	inches	38.1	38.1	41.3	41.3	41.3	41.3	41.3	44.5	44.5	44.5
Max. pipe length	m	1000	1000	1000	1000	1000	1000	1000	1000	1000	1000
Max. height between indoor and outdoor units*	m	50/40	50/40	50/40	50/40	50/40	50/40	50/40	50/40	50/40	50/40
Max. height between indoor units	m	18	18	18	18	18	18	18	18	18	18
Maximum indoor units connectable	quantity	64	64	64	64	64	64	64	64	64	64

**OPERATING LIMITS**

Cooling	°C	-5°/55° Dry bulb									
Heating	°C	-23°/18° Wet bulb									

**PIPE LINE**

Refrigerant / GWP		R410A	R410A	R410A	R410A	R410A	R410A	R410A	R410A	R410A	R410A
Charge	kg	10+10+10	10+10+10	10+10+10	10+10+10	10+10+10	10+10+10	10+10+10	10+10+10	10+10+10	10+10+10



### + PRODUCTS

- COP can reach 6.02.
- Compact design.
- Quiet solution.
- Double coil heat exchanger.

### FEATURES

#### TECHNOLOGY:



R410A FLUID



DC INVERTER

- Capacity range from 8 HP to 36 HP.
- Designed for all commercial uses.
- Inlet water temperature range: From 7 to 45°C.
- Stacked installation.
- Constant EER and COP: no influence from outdoor temperature.
- DC Inverter compressor.

**WATER FLOWLOGIC TECHNICAL DATA**

Outdoor units		YWC220-H13	YWC280-H13	YWC335-H13	
Part number		7SP14H038	7SP14H039	7SP14H040	
<b>POWERS</b>					
Capacity range	HP	8	10	12	
Cooling capacity	kW	22.4	28	33.5	
Heating capacity	kW	25	31.5	37.5	
<b>ELECTRICAL PARAMETERS</b>					
Phase/Tension/Frequency		3P/380-400V/50-60Hz	3P/380-400V/50-60Hz	3P/380-400V/50-60Hz	
Cooling	Rated power input	kW	4.50	6.00	7.70
	Max. power input	kW	13.00	15.00	17.00
	Rated current	A	7.20	9.60	12.32
	Max.current	A	20.79	23.99	27.19
Heating	Rated power input	kW	4.15	5.80	7.80
	Max. power input	kW	13.00	15.00	17.00
	Rated current	A	6.64	9.28	12.47
	Max.current	A	20.79	23.99	27.19
EER /COP			4.98/6.02	4.67/5.43	4.35/4.81
<b>PERFORMANCE</b>					
Water flow (HS)	m <sup>3</sup> /h	4.8	6	7.2	
Sound pressure level (HS)	dB(A)	50	51	53	
Sound power level (HS)	dB(A)	61	62	64	
<b>INSTALLATION</b>					
External dimensions (WxDxH)	mm	775x545x995	775x545x995	775x545x995	
Shipping dimensions (WxDxH)	mm	875x655x1182	875x655x1182	875x655x1182	
Net/Shipping weight	kg	172/183	172/183	172/183	
Compressor type		Scroll DC Inverter	Scroll DC Inverter	Scroll DC Inverter	
Refrigerant / GWP		R410A/2088	R410A/2088	R410A/2088	
Refrigerant charge	kg	2	2	2	
Refrigerant liquid pipe	mm	3/8"	3/8"	1/2"	
Refrigerant gas pipe	mm	3/4"	7/8"	1"	
Oil equalization pipe	mm	3/8"	3/8"	3/8"	
Total pipe length	m	300	300	300	
Max. pipe length (Equivalent/Actual)	m	150/120	150/120	150/120	
Max drop between I.U.&O.U	m	50/40	50/40	50/40	
<b>WATER SIDE</b>					
Inlet water connection pipe	mm	DN32	DN32	DN32	
Outlet water connection pipe	mm	DN32	DN32	DN32	
Pressure drop(inlet and outlet)	Kpa	35	50	70	
Connection type		inner grooved	inner grooved	inner grooved	
Max. system water pressure	Mpa	1.6	1.6	1.6	
Inlet water temperature range (Cooling & Heating)	°C	7°/45°	7°/45°	7°/45°	
<b>CONNECTION RATIO</b>					
Connectable indoor unit ratio	%	50-130	50-130	50-130	
Maximum number of indoor units	unit	13	16	19	

\*All the specifications are tested under nominal condition (in cooling, indoor temp. is 27°C DB/19°C WB; outdoor temp 35°C DB/24WB; in heating, indoor temp. is 20°C DB, in heating, outdoor temp. is 7°C DB/6°CWB).



- EEV inside: for an easier installation.
- High-quality DC fan motor: reduce the indoor unit noise greatly.
- Fashion design.
- Infrared remote controller included.

## + PRODUCTS

- Quiet.
- 3D and long distance air supply.
- Hidden screen.
- Two sides drain.



RCV02  
(included)



RWW05  
(optional)



RWW03  
(optional)



RWW07  
(optional)

## FEATURES

### TECHNOLOGY:



R410A FLUID



ELECTRONIC EXPANSION VALVE

## HBV TECHNICAL DATA

Indoor unit		AWSI-HBV007-N11	AWSI-HBV009-N11	AWSI-HBV012-N11	AWSI-HBV016-N11	AWSI-HBV018-N11	AWSI-HBV024-N11	AWSI-HBV030-N11
Phase		Single phase	Single phase	Single phase	Single phase	Single phase	Single phase	Single phase
Part number		7SP02H012	7SP02H013	7SP02H014	7SP02H017	7SP02H015	7SP02H016	7SP02H018
<b>RATED POWER</b>								
Cooling	kBtu/h	7.5	9.5	12.3	15.3	19.1	24.2	30.7
	kW	<b>2.2</b>	<b>2.8</b>	<b>3.6</b>	<b>4.5</b>	<b>5.6</b>	<b>7.1</b>	<b>9</b>
Heating	kBtu/h	8.5	10.9	13.6	17.1	21.5	27.3	34.1
	kW	<b>2.5</b>	<b>3.2</b>	<b>4</b>	<b>5</b>	<b>6.3</b>	<b>8</b>	<b>10</b>
<b>ELECTRICAL PARAMETERS</b>								
Phase/Tension/Frequency		1P/220-230V/50Hz						
<b>PERFORMANCE</b>								
Airflow	m <sup>3</sup> /h	600	600	600	800/720/650	800	1000	1600/1500/1400
Noise level (LS/MS/HS)	dB(A)	29/31/35	29/31/36	29/33/37	39/36/34	35/39/40	36/40/44	49/44/41
<b>INSTALLATION</b>								
External dimensions (WxHxD)	mm	855x280x200	855x280x200	855x280x200	1115x336x243	1115x336x243	1115x336x243	1115x336x243
Shipping dimensions (WxHxD)	mm	954x355x279	954x355x279	954x355x279	1206x418x342	1206x418x342	1206x418x342	1206x418x342
Net weight/Gross weight	kg	10.9/12.6	10.9/12.6	10.9/12.6	13/16.5	13/16.5	13/16.5	13/16.5
Liquid pipe diameter	inches	1/4"	1/4"	1/4"	1/4"	1/4"	3/8"	3/8"
Suction pipe diameter	inches	3/8"	3/8"	1/2"	1/2"	1/2"	5/8"	5/8"

Dimensions: 007-009-012 models

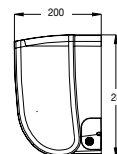
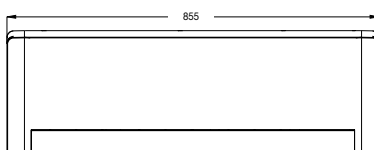

Dimensions: 018-024-030 models

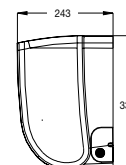
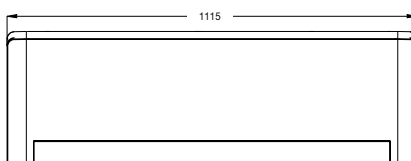



- Easy installation in false ceiling.
- Super quiet due to special fan design.
- Built-in high head pump (height up to 600 mm).
- Possible connection to a ventilation network due to a fresh air inlet (10-15% max).
- Dry contact: hotel/bungalow solutions (room card or on/off contact).



### CBV TECHNICAL DATA

Indoor unit		AWSI-CBV005-N11	AWSI-CBV007-N11	AWSI-CBV009-N11	AWSI-CBV012-N11	AWSI-CBV016-N11
Phase		Single phase	Single phase	Single phase	Single phase	Single phase
Part number		7SP04H020	7SP04H000	7SP04H001	7SP04H002	7SP04H003
<b>RATED POWER</b>						
Cooling	kBtu/h	5.1	7.5	9.5	12.3	15.3
	<b>kW</b>	<b>1.5</b>	<b>2.2</b>	<b>2.8</b>	<b>3.6</b>	<b>4.5</b>
Heating	kBtu/h	5.8	8.5	10.9	13.6	17.1
	<b>kW</b>	<b>1.7</b>	<b>2.5</b>	<b>3.2</b>	<b>4</b>	<b>5</b>
<b>ELECTRICAL PARAMETERS</b>						
Phase/Tension/Frequency		1P/220-230V/50Hz				
<b>PERFORMANCE</b>						
Airflow	m³/h	650	700	700	700	700
Noise level (LS/MS/HS)	dB(A)	28/29/31	29/30/32	29/30/32	29/30/32	29/30/33
<b>INSTALLATION</b>						
External dimensions (WxHxD)	mm	570x570x260	570x570x260	570x570x260	570x570x260	570x570x260
Shipping dimensions (WxHxD)	mm	718x680x380	718x680x380	718x680x380	718x680x380	718x680x380
Net weight/Gross weight	kg	17/21	17/21	19/21	19/21	19/21
Liquid pipe diameter	inches	1/4"	1/4"	1/4"	1/4"	1/4"
Suction pipe diameter	inches	3/8"	3/8"	3/8"	1/2"	1/2"
<b>FRAME</b>						
Frame part number		7ACVFH001	7ACVFH001	7ACVFH001	7ACVFH001	7ACVFH001
External dimensions (WxHxD)	mm	700x700x60	700x700x60	700x700x60	700x700x60	700x700x60
Shipping dimensions (WxHxD)	mm	740x750x115	740x750x115	740x750x115	740x750x115	740x750x115
Net weight/Gross weight	kg	2.8/4.5	2.8/4.5	2.8/4.8	2.8/4.8	2.8/4.8

Dimensions:

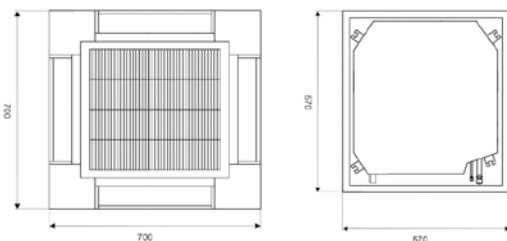

### + PRODUCTS

- Quiet operation.
- Built-in high head drain pump.
- Fresh air inlet.
- Wired controller RWW05 included.
- EEV inside.
- Automatic swing.



RWW05 (included)



RCV02 (optional)



RWW03 (optional)



RWW07 (optional)

### FEATURES

#### TECHNOLOGY:





- Easy installation in false ceiling.
- Possible connection to a ventilation network due to a fresh air inlet (10-15% max).
- Built-in high head pump (height up to 600 mm).
- Better comfort due to its high airflow.
- Dry contact: hotel/bungalow solutions (room card or on/off contact).

### + PRODUCTS

- Compact design.
- Advance structure facilitating cleaning and installation.
- Fresh air inlet.
- EEV inside.
- Wired controller RWW05 included.
- Automatic swing.
- IR receipt included.



RWW05  
(included)



RCV02  
(optional)



RWW03  
(optional)



RWW07  
(optional)

### FEATURES

#### TECHNOLOGY:



R410A FLUID



ELECTRONIC EXPANSION VALVE

### CCV TECHNICAL DATA

Indoor unit		AWSI-CCV018-N11	AWSI-CCV024-N11	AWSI-CCV030-N11	AWSI-CCV048-N11
Phase		Single phase	Single phase	Single phase	Single phase
Part number		7SP04H004	7SP04H005	7SP04H007	7SP04H009
<b>RATED POWER</b>					
Cooling	kBtu/h	19.1	24.2	30.7	47.7
	kW	5.6	7.1	9	14
Heating	kBtu/h	21.5	27.3	34.1	54.6
	kW	6.3	8	10	16
<b>ELECTRICAL PARAMETERS</b>					
Phase/Tension/Frequency		1P/220-230V/50Hz			
<b>PERFORMANCE</b>					
Airflow	m <sup>3</sup> /h	1200	1200	1800	1800
Noise level (LS/MS/HS)	dB(A)	30/32/34	31/35/34	31/35/37	35/39/42
<b>INSTALLATION</b>					
External dimensions (WxHxD)	mm	840x840x240	840x840x240	840x840x295	840x840x295
Shipping dimensions (WxHxD)	mm	930x930x330	930x930x330	930x930x390	930x930x390
Net weight/Gross weight	kg	30/36	30/36	38/40	38/40
Liquid pipe diameter	inches	1/4"	3/8"	3/8"	3/8"
Suction pipe diameter	inches	1/2"	5/8"	5/8"	5/8"
<b>FRAME</b>					
Frame part number		7ACV FH002	7ACV FH002	7ACV FH002	7ACV FH002
External dimensions (WxHxD)	mm	950x950x80	950x950x80	950x950x80	950x950x80
Shipping dimensions (WxHxD)	mm	985x985x115	985x985x115	985x985x115	985x985x115
Net weight/Gross weight	kg	6/9	6/9	6/9	6/9

Be replaced by new CFV model.

Dimensions: 018-024-030-048 models

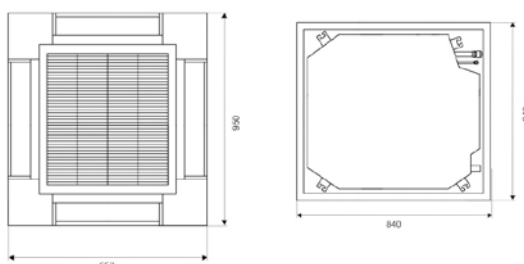



# CFV

## 360° CASSETTE



- Ideal for slim false ceiling.
- Round way airflow.
- Possible connection to a ventilation network due to a fresh air inlet (10-15% max).
- Built-in high head pump (height up to 600 mm).
- Better comfort due to its high airflow.
- Dry contact: hotel/bungalow solutions (room card or on/off contact).

### CFV TECHNICAL DATA

Indoor unit		AWSI-CFV018-N11	AWSI-CFV024-N11	AWSI-CFV030-N11	AWSI-CFV048-N11	AWSI-CFV060-N11
Phase		Single phase	Single phase	Single phase	Single phase	Single phase
Part number		7SP04H028	7SP04H029	7SP04H030	7SP04H032	7SP04H010
<b>RATED POWER</b>						
Cooling	kBtu/h	19.1	24.2	30.7	47.7	54.6
	kW	<b>5.6</b>	<b>7.1</b>	<b>9</b>	<b>14</b>	<b>16</b>
Heating	kBtu/h	21.5	27.3	34.1	54.6	61.2
	kW	<b>6.3</b>	<b>8</b>	<b>10</b>	<b>16</b>	<b>18</b>
<b>ELECTRICAL PARAMETERS</b>						
Phase/Tension/Frequency		1P/220-230V/50Hz				
<b>PERFORMANCE</b>						
Airflow (LS/MS/HS)	m³/h	620/810/1000	1000/1190/1380	1660/1670/2050	1720/1910/2100	1720/1910/2100
Noise level (LS/MS/HS)	dB(A)	29/30/33	31/34/35	31/35/37	36/40/44	36/40/44
<b>INSTALLATION</b>						
External dimensions (WxHxD)	mm	840x183x840	840x204x840	840x246x840	840x288x840	840x288x840
Shipping dimensions (WxHxD)	mm	983x268x983	983x290x983	983x331x983	983x373x983	983x373x983
Net weight/Gross weight	kg	28/31	29/32	34/37	35/38	35/38
Liquid pipe diameter	inches	1/4"	3/8"	3/8"	3/8"	3/8"
Suction pipe diameter	inches	1/2"	5/8"	5/8"	5/8"	5/8"
<b>FRAME</b>						
Frame part number		7ACVFH003	7ACVFH003	7ACVFH003	7ACVFH003	7ACVFH003
External dimensions (WxHxD)	mm	950x50x950	950x50x950	950x50x950	950x50x950	950x50x950
Shipping dimensions (WxHxD)	mm	1013x1025x123	1013x1025x123	1013x1025x123	1013x1025x123	1013x1025x123
Net weight/Gross weight	kg	6.5/9	6.5/9	6.5/9	6.5/9	6.5/9



### + PRODUCTS

- Compact design.
- Fresh air inlet.
- EEV inside.
- Wired controller RWV05 included.



RWV05  
(included)



RCV02  
(optional)



RWV03  
(optional)



RWV07  
(optional)

### FEATURES

#### TECHNOLOGY:



R410A FLUID



ELECTRONIC EXPANSION VALVE



4D AIRFLOW



- Precise control of the airflow via wide angle louvers.
- Floor & ceiling installation.
- Long distance air throw.
- Dry contact: hotel/bungalow solutions (room card or on/off contact).

## + PRODUCTS

- Ultra-thin unit body, only thick 199 mm.
- Wide-angle airflow.
- Quiet running.
- EEV inside.
- Wired controller RWW05 included.
- Automatic swing.



RWW05  
(included)



RCV02  
(optional)



RWW03  
(optional)



RWW07  
(optional)

## FEATURES

### TECHNOLOGY:



R410A FLUID



ELECTRONIC EXPANSION VALVE

## FAV TECHNICAL DATA

Indoor unit		AWSI-FAV009-N11	AWSI-FAV012-N11	AWSI-FAV018-N11	AWSI-FAV024-N11	AWSI-FAV028-N11	AWSI-FAV030-N11	AWSI-FAV038-N11	AWSI-FAV048-N11
Phase		Single phase	Single phase	Single phase	Single phase	Single phase	Single phase	Single phase	Single phase
Part number		7SP02H007	7SP02H008	7SP02H010	7SP02H011	7SP01H000	7SP01H001	7SP01H002	7SP01H003
<b>RATED POWER</b>									
Cooling	kBtu/h	9.5	12.3	19.1	24.2	27.3	30.7	38.2	48
	kW	<b>2.8</b>	<b>3.6</b>	<b>5.6</b>	<b>7.1</b>	<b>8</b>	<b>9</b>	<b>11.2</b>	<b>14</b>
Heating	kBtu/h	10.9	13.6	21.5	27.3	30.7	34.1	42.6	55
	kW	<b>3.2</b>	<b>4.0</b>	<b>6.3</b>	<b>8.0</b>	<b>9</b>	<b>10</b>	<b>12.5</b>	<b>16</b>
<b>ELECTRICAL PARAMETERS</b>									
Phase/Tension/Frequency		1P/220-230V/50Hz							
<b>PERFORMANCE</b>									
Airflow (LS/MS/HS)	m <sup>3</sup> /h	580/710/800	580/710/800	580/710/800	580/710/800	1610/1820/2040	1610/1820/2040	1610/1820/2040	1610/1820/2040
Noise level (LS/MS/HS)	dB(A)	33/35/38	33/35/38	35/37/40	35/37/40	38/40/43	38/40/43	38/42/46	38/42/46
Sound pressure level (LS/MS/HS)		46/48/51	46/48/51	48/50/53	48/50/53	51/53/56	51/53/56	51/55/59	51/55/59
<b>INSTALLATION</b>									
External dimensions (WxHxD)	mm	990x655x199	990x665x199	990x655x199	990x665x199	1580x700x240	1580x700x240	1580x700x240	1580x700x240
Shipping dimensions (WxHxD)	mm	1160x730x280	1160x730x280	1160x730x280	1160x730x280	1720x800x330	1720x800x330	1720x800x330	1720x800x330
Net weight/Gross weight	kg	28.3/34.3	28.3/36.4	28.3/36.4	28.3/36.4	50/57	50/57	54/61	54/61
Liquid pipe diameter	inches	1/4"	1/4"	1/4"	3/8"	3/8"	3/8"	3/8"	3/8"
Suction pipe diameter	inches	3/8"	1/2"	1/2"	5/8"	5/8"	5/8"	5/8"	5/8"

Dimensions: 012 to 024 models

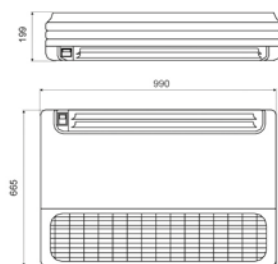

Dimensions: 28 to 48 models

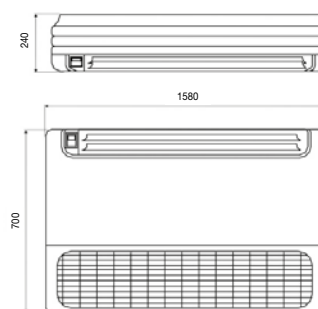



- Super slim design: 185 mm.
- Reserved fresh air inlet.
- Build-in high head drain pump.
- Friendly design of rear or bottom air return.
- Quiet operation.
- Static pressure: 0-30 Pa.



### + PRODUCTS

- Wired controller RWW05 included.
- Wide range.
- Quiet solution.



RWW05  
(included)



RCV02  
(optional)



RWW03  
(optional)



RWW07  
(optional)

### DDV TECHNICAL DATA

Indoor unit		AWSI-DDV007-N11	AWSI-DDV009-N11	AWSI-DDV012-N11	AWSI-DDV016-N11
Phase		Single phase	Single phase	Single phase	Single phase
Part number		7SP03H025	7SP03H026	7SP03H027	7SP03H028
<b>RATED POWERS</b>					
Cooling	kBtu/h	7.5	9.5	12.3	15.3
	kW	<b>2.2</b>	<b>2.8</b>	<b>3.6</b>	<b>4.5</b>
Heating	kBtu/h	8.5	10.9	13.6	17.1
	kW	<b>2.5</b>	<b>3.2</b>	<b>4</b>	<b>5</b>
<b>ELECTRICAL PARAMETERS</b>					
Power supply	Ph/V/Hz	1P/220-230V/50-60Hz			
<b>PERFORMANCE</b>					
Airflow (LS/MS/HS)	m³/h	480/420/360	480/420/360	550/430/370	600/540/460
Noise level (LS/MS/HS)	dB(A)	27/24/21	27/24/21	30/28/25	33/30/27
Sound power level (LS/MS/HS)	dB(A)	41/38/35	41/38/35	44/42/39	47/44/41
<b>INSTALLATION</b>					
External dimensions (WxHxD)	mm	850x420x185	850x420x185	850x420x185	850x420x185
Shipping dimensions (WxHxD)	mm	1045x540x270	1045x540x270	1045x540x270	1045x540x270
Net weight/Gross weight	kg	17.5/22.5	17.5/22.5	17.5/22.5	18.5/23.5
Liquid pipe diameter	inches	1/4"	1/4"	1/4"	1/4"
Suction pipe diameter	inches	3/8"	3/8"	1/2"	1/2"
External static pressure (standard/max)	Pa	0/30	0/30	0/30	0/30
Motorized panel and return air grill		7ACVFH0587	7ACVFH0587	7ACVFH0587	7ACVFH0587

### FEATURES

#### TECHNOLOGY:





## + PRODUCTS

- Flexible static pressure selection, meeting the customers' personal requests.
- High efficiency filter.
- Water pump integrated.
- EEV inside.
- Wired controller RWW05 included.



RWW05  
(included)



RCV02  
(optional)



(RECO1  
infrared  
receiver to  
be combined  
with RCV02)



RWW03  
(optional)



RWW07  
(optional)

## FEATURES

### TECHNOLOGY:



R410A FLUID



ELECTRONIC  
EXPANSION VALVE

### INSTALLER FUNCTIONS:



INTEGRATED WATER  
PUMP



- Invisible solution.
- Two choices of static pressure: better fitting with aeraulic network.
- Built-in high head pump (height up to 700 mm).
- Plenum for air outlet provided: 3xØ200 sizes 018 and 028, 4xØ200 size 038.
- Dry contact: hotel/bungalow solutions (room card or on/off contact).

## DBV TECHNICAL DATA

Indoor unit		AWSI-DBV 018-N11	AWSI-DBV 024-N11	AWSI-DBV 028-N11	AWSI-DBV 030-N11	AWSI-DBV 038-N11	AWSI-DBV 048-N11
Phase		Single phase	Single phase	Single phase	Single phase	Single phase	Single phase
Part number		7SP03H035	7SP03H036	7SP03H037	7SP03H038	7SP03H039	7SP03H040
<b>RATED POWER</b>							
Cooling	kBtu/h	19.1	24.2	27.3	30.7	38.2	47.8
	kW	<b>5.6</b>	<b>7.1</b>	<b>8</b>	<b>9</b>	<b>11.2</b>	<b>14</b>
Heating	kBtu/h	21.5	27.3	30.7	34.1	44.3	55.6
	kW	<b>6.3</b>	<b>8</b>	<b>9</b>	<b>10</b>	<b>13</b>	<b>16.3</b>
<b>ELECTRICAL PARAMETERS</b>							
Phase/Tension/Frequency		1P/230V/50Hz					
<b>PERFORMANCE</b>							
Airflow (LS/MS/HS)	m³/h	36/38/40	38/40/42	39/43/46	38/42/46	39/43/46	39/44/47
Noise level (LS/MS/HS)	dB(A)	699/805/920	950/1090/1230	950/1090/1230	930/1180/1500	900/1300/1700	1250/1700/2000
<b>INSTALLATION</b>							
External dimensions (WxHxD)	mm	1050x720x250	1050x720x250	1050x720x250	1100x700x248	1500x700x248	1500x700x248
Shipping dimensions (WxHxD)	mm	1170x860x340	1170x860x340	1170x860x340	1332x835x280	1698x857x305	1698x857x305
Net weight/Gross weight	kg	30.5/35.9	33.1/38.5	33.1/38.5	39.4/45.4	48.3/56.5	51.3/59.5
Liquid pipe diameter	inches	1/2"	3/8"	3/8"	3/8"	3/8"	3/8"
Suction pipe diameter	inches	1/4"	5/8"	5/8"	5/8"	5/8"	5/8"
Static pressure	Pa	50	50	50	50	50	50
Max. static pressure	Pa	100	100	100	100	100	100



DCV 048



DCV 072-096

- Invisible solution.
- Static pressure up to 196 Pa.
- Commercial application: high airflow and capacity up to 28 kW.
- Compatible with a textile duct application.



### DCV TECHNICAL DATA

Indoor unit		AWSI-DCV018-N11	AWSI-DCV024-N11	AWSI-DCV030-N11	AWSI-DCV038-N11	AWSI-DCV048-N11	AWSI-DCV072-N11	AWSI-DCV096-N11
Phase		Single phase	Single phase	Single phase	Single phase	Single phase	Single phase	Single phase
Part number		7SP03H014	7SP03H015	7SP03H016	7SP03H017	7SP03H018	7SP03H019	7SP03H020
<b>RATED POWER</b>								
Cooling	kBtu/h	19.1	24.2	30.7	38.2	47.7	77.1	95.5
	kW	<b>5.6</b>	<b>7.1</b>	<b>9</b>	<b>11.2</b>	<b>14</b>	<b>22.6</b>	<b>28</b>
Heating	kBtu/h	21.5	27.3	34.1	42.6	54.6	85.3	108.5
	kW	<b>6.3</b>	<b>8</b>	<b>10</b>	<b>12.5</b>	<b>16</b>	<b>25</b>	<b>31.5</b>
<b>ELECTRICAL PARAMETERS</b>								
Phase/Tension/Frequency		1P/220-230V/50Hz						
<b>PERFORMANCE</b>								
Airflow (LS/MS/HS)	m³/h	1089/1357/1500	1089/1357/1500	1133/1412/1560	1162/1448/1600	1525/1901/2100	2612/3255/4050	2612/3255/4050
Noise level (LS/MS/HS)	dB(A)	38/40/42	38/40/42	40/43/45	40/43/45	40/43/45	49/51/54	49/51/54
<b>INSTALLATION</b>								
External dimensions (WxHxD)	mm	975x906x360	975x906x360	1355x876x360	1355x876x360	1197x360x830	1570x360x880	1570x360x880
Shipping dimensions (WxHxD)	mm	1048x943x413	1048x943x413	1378x938x405	1378x938x405	1430x420x940	1800x525x1000	1800x525x1000
Net weight/Gross weight	kg	48/58	48/58	62/77	62/77	62/77	100/111	100/111
Liquid pipe diameter	inches	1/4"	3/8"	3/8"	3/8"	3/8"	3/8"	3/8"
Suction pipe diameter	inches	1/2"	5/8"	5/8"	5/8"	5/8"	1"	1"
Static pressure	Pa	100/196	100/196	100/196	100/196	196	196	196

Dimensions: 018-024/030-038/048 models

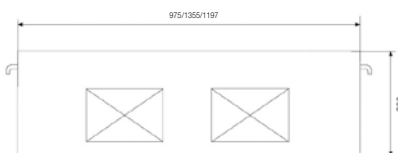

Dimensions: 072-096 models



### + PRODUCTS

- High efficiency filter.
- Free setting of air discharge duct.
- Water pump integrated.
- High external static pressure design.



RWW05 (included)



RCV02 (optional)



RWW03 (optional)



RWW07 (optional)

### FEATURES

#### TECHNOLOGY:



R410A FLUID



ELECTRONIC EXPANSION VALVE

#### INSTALLER FUNCTIONS:



INTEGRATED WATER PUMP



## + PRODUCTS

- High efficiency filter.
- Quiet running.
- Compact unit body and space saving.
- EEV inside.
- Wireless controller included.



RCV02  
(included)



RWV05  
(optional)



RWV07  
(optional)

## FEATURES

### TECHNOLOGY:



R410A FLUID



ELECTRONIC EXPANSION VALVE



- Esthetic and compact design: 210 mm.
- Ideal solution to replace electric heaters.
- Blowing up and down.
- Dry contact: hotel/bungalow solutions (room card or on/off contact).
- 5 speed airflow.

### EAV TECHNICAL DATA

Indoor unit		AW-EAV009-N11	AW-EAV012-N11	AW-EAV018-N11
Phase		Single phase	Single phase	Single phase
Part number		7SP05H005	7SP05H006	7SP05H007
<b>RATED POWER</b>				
Cooling	kBtu/h	9.5	12.3	17
	kW	<b>2.8</b>	<b>3.6</b>	<b>5</b>
Heating	kBtu/h	10.9	13.6	18.5
	kW	<b>3.2</b>	<b>4</b>	<b>5.5</b>
<b>ELECTRICAL PARAMETERS</b>				
Phase/Tension/Frequency		1P/230V/50Hz		
<b>PERFORMANCE</b>				
Airflow (VL/LS/MS/HS/VH)	m <sup>3</sup> /h	45/48/52/55/58	47/51/54/57/60	48/52/55/58/61
Noise level (VL/LS/MS/HS/VH)	dB(A)	540/460/390/310/270	580/500/420/350/270	620/540/460/390/270
<b>INSTALLATION</b>				
External dimensions (WxHxD)	mm	700x600x210	700x600x210	700x600x210
Shipping dimensions (WxHxD)	mm	783x695x303	783x695x303	783x695x303
Net weight/Gross weight	kg	15.2/18.7	15.2/18.7	15.2/18.7
Liquid pipe diameter	inches	1/2"	1/2"	1/2"
Suction pipe diameter	inches	1/4"	1/4"	1/4"

Dimensions: 009-018 models

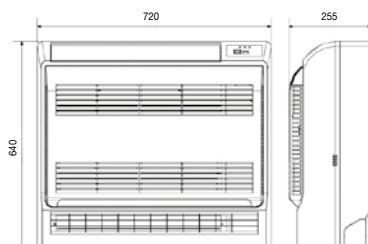

A series of horizontal dotted lines spanning the width of the page, intended for handwritten notes or text.

# AHU Connection Kit

Airwell offers a range of connection kits to connect VRF outdoor units to third party DX air handling units.

## SYSTEM APPLICATION

- Provides a solution for big space to cool down the supplied fresh air with VRF outdoor units to match the air handling units. Integrates all advantages of VRF and AHU units.
- EU legislation requires that every working place has to be supplied with a minimum of 25 m<sup>3</sup>/h/person of fresh air. So it means that every office, every shop and mostly every commercial building MUST have this solution in order to comply with the standard.



Buildings



Shopping centres



Hospitals

### ■ CONFIGURATION BETWEEN 14 AND 28 KW

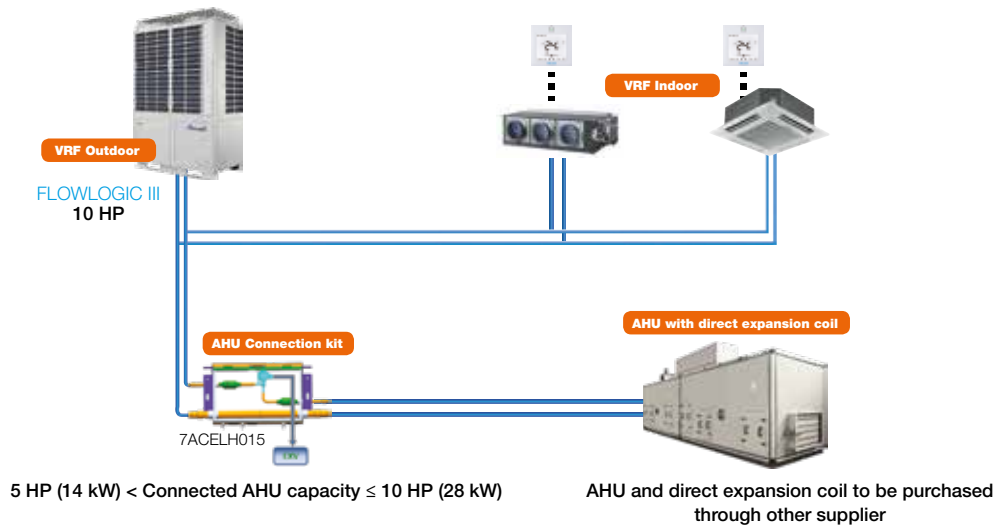

### ■ CONFIGURATION BETWEEN 28 AND 56 KW

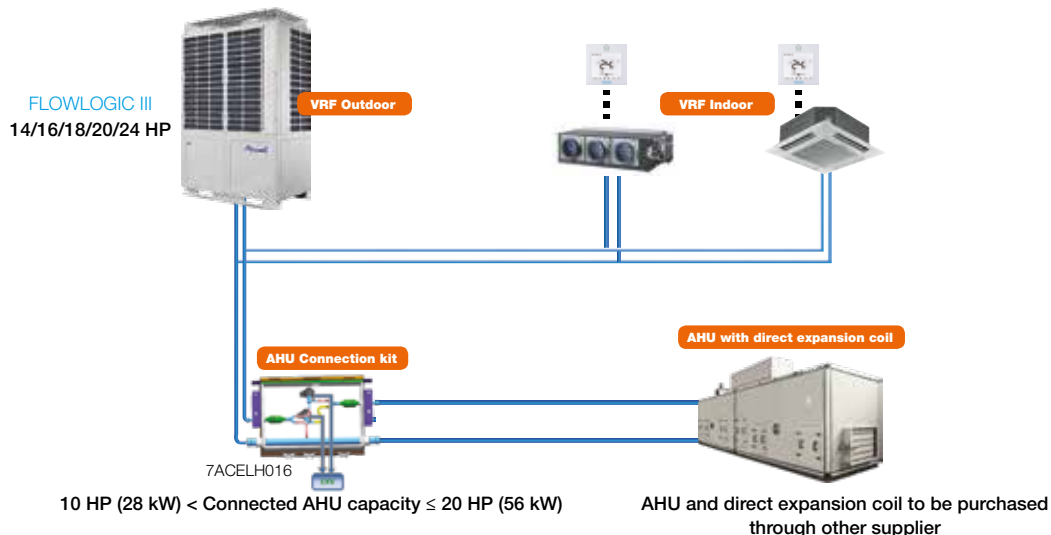



## VRF OUTDOOR LINE UP

OUTDOOR	FLOWLOGIC III	
Modèle	All range	
		
Power supply	3P/380-400V/50Hz - 3P/380-400V/60Hz 3P/220V/60Hz - 3P/460V/60Hz	
AHU kit	<b>7ACELH015</b>	<b>7ACELH016</b>
	5 HP (14 kW) < Connected AHU capacity ≤ 10 HP (28 kW)	10 HP (28 kW) < Connected AHU capacity ≤ 20 HP (56 kW)

## AHU KIT CONFIGURATION

Airwell AHU Connection Kit consists in the following 4 parts:



Different Valve ▼ Same Control Parts



- EXV part, Control part, Sensor and wire are all integrated in one box.
- Controller need to be purchased separately.
- Temperature control via outlet air sensor on AHU.

## WIRING DIAGRAM

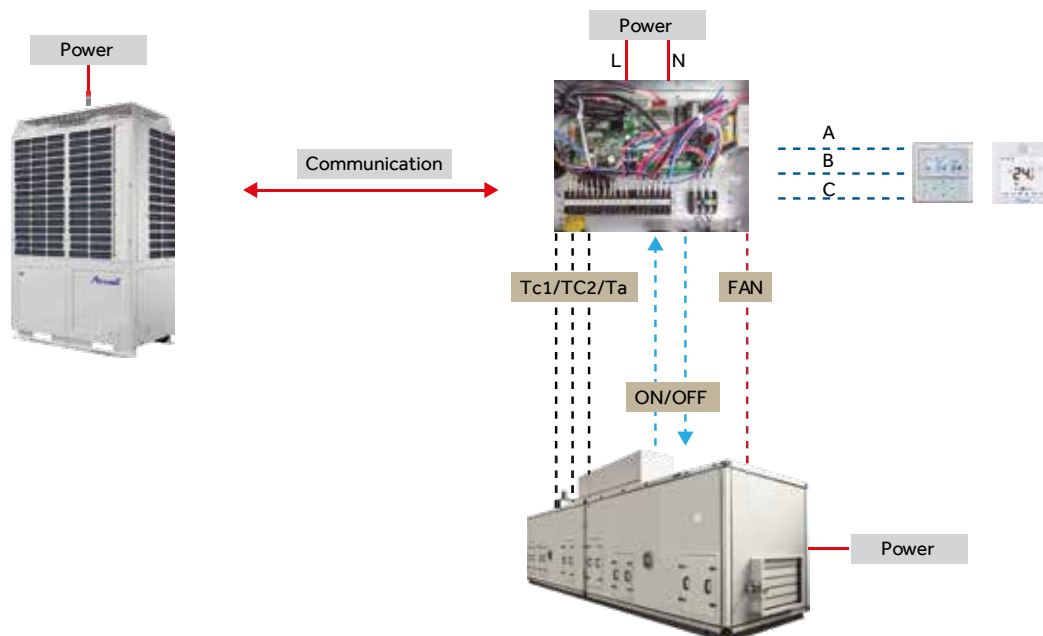

# Central control solutions with ADV05

## ONLY ONE GATEWAY: CENTRAL CONTROL OR MODBUS

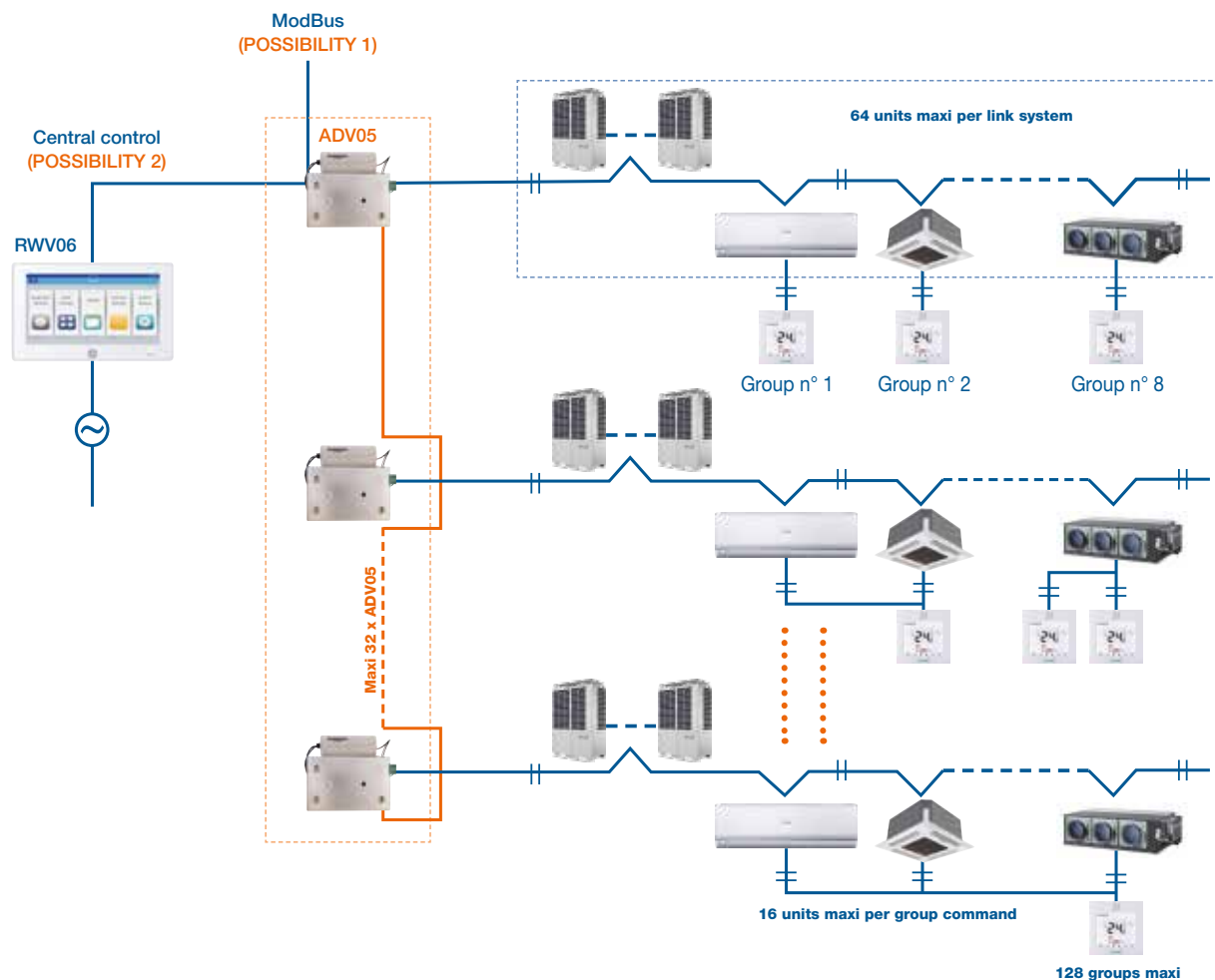

## TOUCH SCREEN CENTRAL REMOTE CONTROL RWW06

This command allows you to control and monitor the status of indoor units:

- Modern design
- Intuitive and simple operation thanks to its 7" touch screen
- Can monitors until 256 indoor units and 128 groups







The main functions are:























- Reading operating parameters
- Visualization of failure code
- Weekly time: mode, fan speed, temperature
- Sets LIFO (Last enter have high priority)
- Creation and monitoring zones
- Modbus RS485 -+

Part number RWW06: 7ACELH023



ACCESSORY NAME		Photo	Part number	Model
CONTROLLERS	INFRARED CONTROLLER		<b>7ACELH022</b>	<b>RCV02</b>
	INFRARED CONTROLLER RECEIVER		<b>7ACELH009</b>	<b>REC01</b>
	SIMPLIFIED CONTROLLER		<b>7ACELH008</b>	<b>RWV03</b>
	WIRED STANDARD CONTROLLER		<b>7ACELH021</b>	<b>RWV05</b>
	WIRED CONTROL WEEKLY TIMER		<b>7ACELH024</b>	<b>RWV07</b>
	MINI CENTRAL CONTROLLER		<b>7ACELH025</b>	<b>RWV08</b>
	CENTRAL CONTROLLER "TOUCH SCREEN"		<b>7ACELH023</b>	<b>RWV06</b>
BMS SOLUTIONS & MAINTENANCE	CENTRAL CONTROLLER GATEWAY AND MODBUS/RTU		<b>7ACELH027</b>	<b>ADV05</b>
	MAINTENANCE TOOL		<b>7ACELH014</b>	<b>TD02</b>

FUNCTION	FOR WHAT UNITS?	OPTION/COMMENT
On/Off, set temperature, auto scan, mode, individual control, timer.	All indoor units.	Standard with high wall and console, optional with cassette and ducted.
Realize infrared control.	Ducted	-
Unit operating and group control (max. 16 indoor units).	All indoor unit types (except for console).	-
Unit operating, group control (max. 16 indoor units) and "I Feel" function.	High wall, ducted cassette, floor ceiling.	Standard with cassette, ducted and floor ceiling.
Single unit control, group control, max. 16 units, weekly timer, clock, mode cooling/heating/auto/airflow/dehumidification, temperature, fan speed, fan direction.	High wall, cassette, ducted, floor ceiling.	-
32 indoor units max., individual control, group control, central control, weekly timer, error display.	Mini FlowLogic II FlowLogic III FlowLogic II HR	ADV05 mandatory.
Central control, single unit control, group control, max. 256 units, weekly timer, clock, mode cooling/heating/auto/airflow/dehumidification, temperature, fan speed, fan direction.	Mini FlowLogic II FlowLogic III FlowLogic II HR	ADV05 mandatory.
RWV06 and RWV08 adaptor and ModBus RTU gateway.	Mini FlowLogic II FlowLogic III FlowLogic II HR	-
Working parameters monitoring and recording tool.	Mini FlowLogic II FlowLogic III FlowLogic II HR	-

		WIRED REMOTE					
		RC08A	RC08C	RCV02	RCW4	RCW6	RCWE
<b>RANGE</b>		- 	7ACEL1740 	7ACELH022 	7ACEL1613 	7ACEL1704 	7ACEL1647 
<b>HIGH WALL</b>	HHF						
	HFT						
	HDT						
<b>DUCTED</b>	DAF						
	DDT						
<b>FLOOR-STANDING</b>	FSF						
<b>VRF</b>	HBV						
	CBV						
	CCV						
	FAV						
	DAV						
	DBV						
	DCV						
	EAV						









**RESIDENTIAL**

		INFRARED CONTROL	WIRED REMOTE	
		RC08C	RCW6	RCW8
		7ACEL1740 	7ACEL1704 	7ACEL1706 
<b>CUSTOMER</b>	FUNCTION			
	On/Off Timer	<input checked="" type="checkbox"/>	<input checked="" type="checkbox"/>	<input checked="" type="checkbox"/>
	Weekly Timer		<input checked="" type="checkbox"/>	
	Silent mode / low speed fan	<input checked="" type="checkbox"/>	<input checked="" type="checkbox"/>	<input checked="" type="checkbox"/>
	"I Feel" function	<input checked="" type="checkbox"/>		
	Clean-up function	<input checked="" type="checkbox"/>		
	Night mode (economy mode)	<input checked="" type="checkbox"/>		<input checked="" type="checkbox"/>
	Remote locking			<input checked="" type="checkbox"/>
	Turbo mode	<input checked="" type="checkbox"/>		
	"Follow me" mode (presence sensor)		<input checked="" type="checkbox"/>	
	Low Battery	<input checked="" type="checkbox"/>	<input checked="" type="checkbox"/>	<input checked="" type="checkbox"/>
	No frost mode	<input checked="" type="checkbox"/>		
<b>INSTALLER</b>	Test mode	<input checked="" type="checkbox"/>		
	Group control		<input checked="" type="checkbox"/>	
	Temperature compensation	<input checked="" type="checkbox"/>		
	Heating mode only	<input checked="" type="checkbox"/>		
	Priority mode definition (multisplit)	<input checked="" type="checkbox"/>		
	Parameter display (temperature, off pressure opening, compressor...)	<input checked="" type="checkbox"/>		
	Defaults, failures display			



**VRF**

FUNCTION	INFRARED CONTROL	WIRED REMOTE					
	RCV02	RWV05	RWV07	RWV03	RWV06	RWV08	TD02
	7ACELH022	7ACELH021	7ACELH024	7ACELH008	7ACELH023	7ACELH025	7ACELH014
							
On/Off Timer	●	●	●	●	●	●	
Weekly Timer			●		●	●	
Silent mode / low speed fan		●	●	●	●	●	
"I Feel" function						●	
CUSTOMER	Clean-up function		●	●	●	●	
	Night mode (economy mode)		●	●		●	
	Remote locking		●	●		●	
	Turbo mode			●			
"Follow me" mode (presence sensor)			●				
Low Battery	●	●	●	●	●	●	
INSTALLER	Supervision						●
	Group control		●	●	●	●	
	Centralized control					●	●
	Heating mode only		●	●			
	Defaults, failures display		●	●	●	●	●

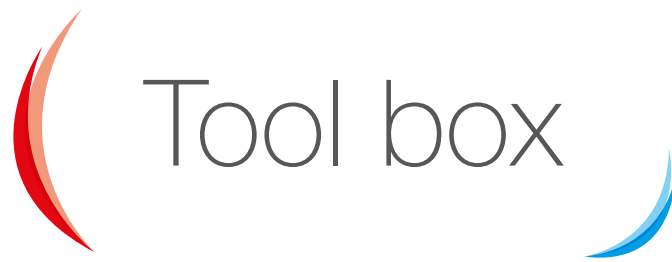

## MEASURE UNITS CONVERSION

Length			
1 inch (in)	0.0254 m		
1 foot (ft)	12 inches	0.3048 m	
1 yard (yd)	3 feet	0.9143 m	
1 mile (mi)	1.760 yards	1609 m	
1 nautical mile (nmi)	1852 m		
1 meter (m)	39.37 inches	3.28084 feet	1.09361 yard

mm	Inches
6.35	1/4
9.52	3/8
12.70	1/2
15.88	5/8
19.05	3/4
22.22	7/8
25.40	1
28.58	1 1/8
31.75	1 1/4
38.10	1 1/2

Volume	
1 cubic inch (cu in)	16.387064 cm <sup>3</sup>
1 cubic foot (cu ft)	0.028317 m <sup>3</sup> /28.31685 dm <sup>3</sup>
1 cubic yard (cu yd)	0.76455 m <sup>3</sup>
1 pint	0.568 l
1 gallon-imp	4.546 l
1 gallon (US gal)	3.78541 l or dm <sup>3</sup>
1 cubic meter (m <sup>3</sup> )	35.31467 cu ft
1 cubic decimeter (dm <sup>3</sup> )	0.26428 gal
1 liter (l)	1 dm <sup>3</sup>

HP (horse power) *	Btu	kW
1	9000	2.637
1.5	12000	3.516
2	18000	5.274
2.5	24000	7.032
3	30000	8.79
5	45000	13.185

Mass volume	
1 cu.ft/lb	62.43 dm <sup>3</sup> /kg
1 US gallon/pound	8.3 dm <sup>3</sup> /kg

Density	
1 pound/cu.ft	0.016 kg/dm <sup>3</sup>

Mass		
1 ounce (oz)	28.349 g	
1 pound (lb)	16 oz	0.4536 kg
1 quintal U.S	100 lbs	
1 centweight	112 lbs	
1 short ton (US)	2000 lbs	907.18 kg
1 long ton (GB)	2240 lbs	1016.04 kg
1 quintal (q)	100 kg	
1 tonne (t)	1000 kg	

Area		
1 square inch (in <sup>2</sup> )	6.4516 cm <sup>2</sup>	
1 square foot (ft <sup>2</sup> )	0.0929 m <sup>2</sup>	
1 square yard (yd <sup>2</sup> )	0.8361 m <sup>2</sup>	
1 square meter (m <sup>2</sup> )	1550 in <sup>2</sup>	10.76391 ft <sup>2</sup>

Energy - Heat quantity		
1 cal	4.18 joules	
1 Btu	0.252 kcal	1055 joules
1 Btu/lb.°F	1 kcal/kg °C	
1 kcal	1 millithermie	
1 fg/h	-1 kcal/h	
1 kcal/h	1.163 W	
1 Btu/h	0.293 W	
1 ton (US)	3024 kcal/h	3512 W
1 ton (GB)	3340 kcal/h	3878 W
1 watt (thermic)	0.86 kcal/h	

- ° Fahrenheit = °C x 9/5 + 32
- ° Celsius = (°F-32) x 5/9
- ° Celsius = T (Kelvin) - 273.15
- \* Indicative values

Rated power of our products are given for air conditions as following:  
 Cooling mode: 35°C out/27°C in (Dry bulb)  
 Heating mode: +7°C out/20°C in (Dry bulb)

## SIZING THE AIR CONDITIONING

---

### STEP 1: EVALUATING THE NEEDS

In order to size properly your air conditioning installation, it's important to calculate the thermal needs of your habitation to calculate the power needed for your setup.

#### ■ SIZING THE COOLING NEEDS BY OCCUPANCY RATIO

We use the following ratio to calculate the cooling power needed:

$$90 \text{ W/m}^2 + 100 \text{ W/Occupant}$$

The calculation is to be done room by room.

#### ■ SIZING THE HEATING NEEDS BY THE G METHOD

The « G » is the volume loss coefficient of the building, matching the sum of the thermal loss through walls, windows, roofs... It's expressed in  $\text{W/m}^3/\text{°C}$ . This coefficient is related to the building isolation.

$$\text{Heat power (W)} = G \times V \times \Delta T$$

**G** = global loss coefficient ( $\text{W/m}^3 \times \text{°C}$ ):

- 0,65  $\text{W/°C m}^3$  new construction
- 0,75  $\text{W/°C m}^3$  construction after 2000
- 0,9  $\text{W/°C m}^3$  constructions after 1980
- 1,2  $\text{W/°C m}^3$  constructions moderately insulated
- 1,8  $\text{W/°C m}^3$  constructions poorly insulated

**V** = building volume ( $\text{m}^3$ )

**$\Delta T$**  = Temperature difference between interior (19 or 20°C), and average exterior temperature in the region where is based the project.

## STEP 2: EXTERIOR UNITS SELECTION

Dispatch the cooling and heating needs calculated before (cf. step 1).

Calculate the global needs by zone, in order to determine outdoor unit capacity.

STEP 2: EXTERIOR UNIT SELECTION				
Zone	Rooms	Cooling needed (kW)	Heating needed (kW)	Maximum number of interior units desired
Zone 1	Room n°1			
	Room n°2			
	Room n°3			
	Room n°4			
	Room n°5			
	Room n°6			
	<b>TOTAL</b>			
Zone 2	Room n°1			
	Room n°2			
	Room n°3			
	Room n°4			
	Room n°5			
	Room n°6			
	<b>TOTAL</b>			
Zone 3	Room n°1			
	Room n°2			
	Room n°3			
	Room n°4			
	Room n°5			
	Room n°6			
	<b>TOTAL</b>			

## TECHNOLOGY



### FLEXY MATCH

Indoor units are compatible with monosplit or multisplit installation.



### DC INVERTER

Compressor with high efficiency DC engine.



### R410A FLUID

Refrigerant fluid R410A.



### R407C FLUID

Refrigerant fluid R407C.



### R32 FLUID

Refrigerant fluid R32.



### ELECTRONIC EXPANSION VALVE

Precise control of coolant flow, optimization of performance and compressor protection.



### 4D AIRFLOW

Heating and cooling operations are optimized with an automatic horizontal and vertical oscillation.



### MULTIFLOW 360°

Air distribution system with great comfort on 360° and 4 directions with motorized opening control.



### TWIN APPLICATION

An outdoor unit is connected to two similar indoor units.



### CRANKCASE HEATER

Protects compressor oil from freezing.

## AIR QUALITY/CLEAN



### STERIONIZER

Generates sterionizer ions producing electrochemical reaction destroying bacteria, viruses and allergenic particles. Creates and ensure provisioning of natural and high quality air in living environment.



### NANO PHOTOCATALYTIC FILTER

Oxidizes and degrades organic contaminants. It can eliminate up to 99.9% of bacteria and can efficiently block dusts.



### GOLDEN FINS CONDENSER

Improve heat transfer efficiency and corrosion resistance.



### AIR FILTER

Eliminates fine particles and purifies the air.



### AUTO CLEAN/DRY

Prevents development of bacteria and moistures keeping the heat exchanger dry after a cooling operation.



### FRESH AIR

Cools the room bringing fresh air from outside.



### FILTER CLEAN INDICATION

Control led asking for verification and cleaning of the air filter.

## USER FUNCTIONS



### I FEEL

Precise control of temperature all around the chosen zone via a remote temperature sensor.



### NIGHT MODE

Temperature in the room adjustment based on sleeping habits.



### QUIET MODE

Top design for the lowest sound level.



### REFRIGERANT LEAKAGE DETECT

Indicates a refrigerant leakage on indoor unit and stops the system for compressor protection.



### PROGRAMMABLE TIMER

Adjustable timer for power on and power off.



### AUTO RESTART (MEMORY)

Restarts automatically the unit in the last used mode when power is back.



### REMOTE CONTROL LOCK

Locks the remote functions to avoid unexpected actions.



### WIFI

Air conditioner controlled via mobile phone, tablet or computer through a wireless router and internet, thanks to AIR NET application.



### REDUNDANCY FUNCTION

Product compatible with Airwell redundancy solution.

## INSTALLER FUNCTIONS



### ERROR CODE VIA INDOOR UNIT

Digital display of error codes or temperature settings on the indoor unit.



### SELF DIAGNOSTIC

Unit failure indication through a blinking led on the unit display.



### INTEGRATED WATER PUMP

Eliminates condensate for a simple and smooth use.



### LEFT/RIGHT DRAIN CONNECTION

Easy installation connecting condensate tubing either on left or right side.



### ALARM OUTPUT

Remote transmission of dysfunction errors.



### UNIT ON OUTPUT

Displays on the remote the power on or power off status of the unit.



### DRY CONTACT ON/OFF

Connection to an external presence detection with adjusted control of the unit and power saving when the room is empty.



### BMS COMPATIBLE

Connection to the BMS system via PCB adapter.



### SERVICE MONITOR TOOL

PC interface for monitoring and adjusting the settings of the unit.



### POWER CONSUMPTION CONTROL

Energy consumption control reducing the maximum power on the unit.



### OUTDOOR UNIT NIGHT MODE DRY CONTACT

Engine speed limitation and noise level reduction of the outdoor unit.



### OUTDOOR UNIT STAND-BY

Power on or power off of the outdoor unit from the remote.



### OUTDOOR UNIT ALARM OUTPUT

Transmission of an air output default alarm to a remote system.



### TECHNICIAN TEST MODE

Special mode optimizing the duration of intervention of the technician.

# Airwell

AIR CONDITIONING & HEATING

## Our after-sales service

tel ■ +33 (0)1 76 21 82 95

**SPARE PARTS ORDERS:**  
e-mail ■ [sp@airwell-res.com](mailto:sp@airwell-res.com)

**TECHNICAL SUPPORT:**  
e-mail ■ [sav@airwell-res.com](mailto:sav@airwell-res.com)

**Airwell**  
**Residential**

3, AVENUE DU CENTRE, LES QUADRANTS, BÂT. A - 78280 GUYANCOURT, FRANCE  
TEL.: +33 (0)1 76 21 82 00 - FAX: +33 (0)1 76 21 82 01 - [www.airwell-res.com](http://www.airwell-res.com)