

INSTALLATION & OWNER'S MANUAL

MONOBLOC BACKUP HEATER

BH30A

Thank you very much for purchasing our product,
Before using your unit , please read this manual carefully and keep it for future reference.

ABOUT THE DOCUMENTATION.....	1
ABOUT THE BOX.....	1
PREPARATION.....	2
INSTALLATION.....	3
STARTING UP THE SYSTEM.....	6
MAIN PARAMETERS.....	6

1. ABOUT THE DOCUMENTATION

This document is prepared for authorised installers, read this document carefully before installation. Keep this manual in a handy place for future reference.

Improper installation or attachment of equipment or accessories could result in electrical shock, short circuit, leaks, fire or other damage to the equipment.





All activities described in this manual shall be carried out by a licensed technician.

Be sure to wear adequate personal protection equipment(Protection gloves, safety glasses) when performing installation, maintenance or service to the unit.

If unsure of installation procedure or use, always contact your dealer for advice and information.

The unit described here is designed for indoor installation.

Table 1-1

INSTALLATION FITTINGS		
NAME	SHAPE	QUANTITY
Installation & owner's manual(this book)		1
Mounting bracket		1
Mounting bracket		1
M8 expansion screws		3
M4 screws		2

2. ABOUT THE BOX

2.1 Backup heater

2.1.1 Structure of the backup heater

- 1) Remove the front cover of the backup heater.

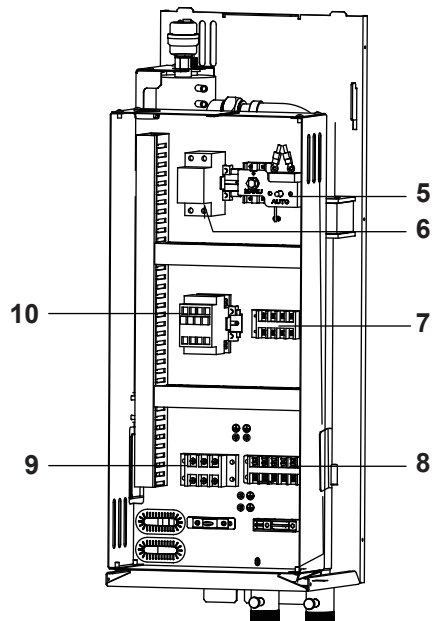
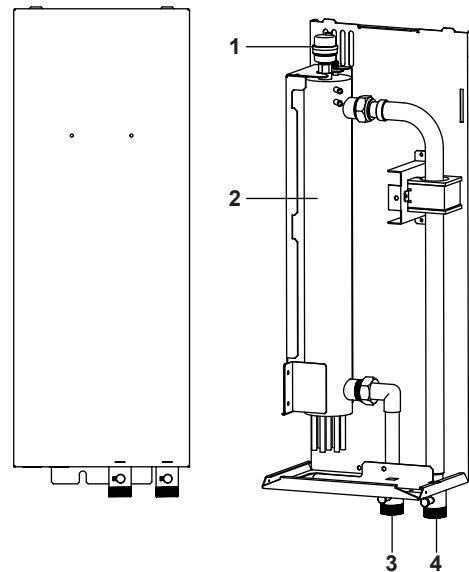

- 1 Air purge
- 2 Backup heater
- 3 Water IN connection
- 4 Water OUT connection
- 5 Thermal protector
- 6 Circuit breaker
- 7 Terminal block
- 8 Terminal block
- 9 Terminal block
- 10 Backup heater contactor

3. PREPARATION

3.1 Preparing installation site

3.1.1 Installation site requirements of the backup heater

- Keep in mind the guidelines for the measures:

Maximum distance between the backup heater and the external drive	5m (If you exceed this distance, you need an additional water pump)
Operating range (Internal installation)	5~35°C

- Mind the following spacing installation guidelines:

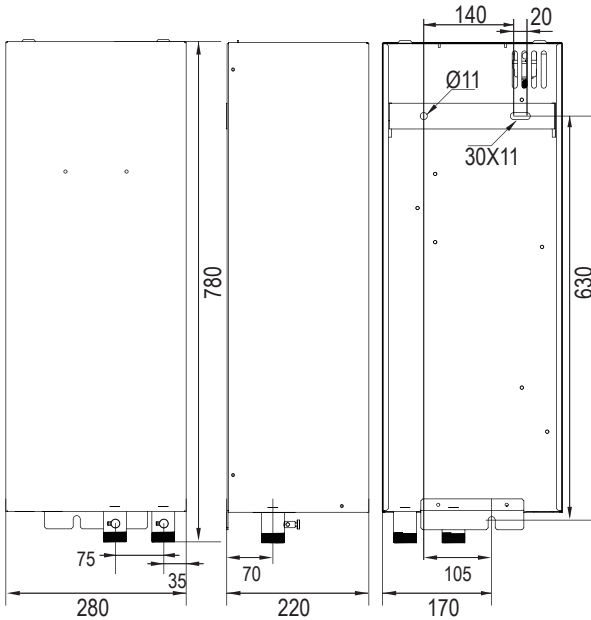
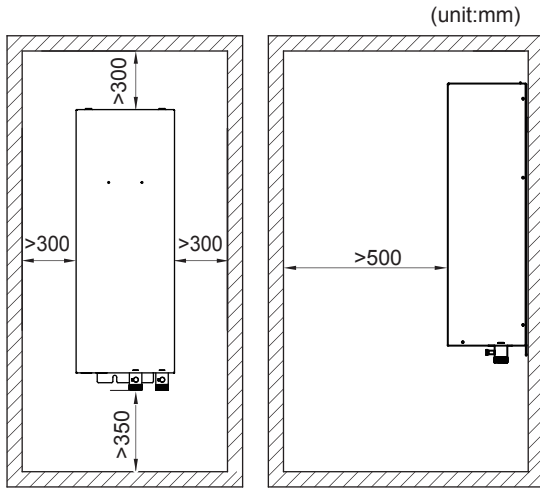

- The backup heater is designed to be wall mounted in indoor locations only.
Make sure the installation surface is a flat and vertical noncombustible wall.

3.2 Preparing water piping

When installing the backup heater in the system, make sure the required minimum water flow rate is guaranteed at all times. For more information, refer to the installation manual of the outdoor unit.

3.3 Preparing electrical wiring

3.3.1 Overview of electrical connections for external and internal actuators

Item	Description	Wires	Maximum running current
Interconnection cable			
1	Interconnection cable between backup heater kit and outdoor unit	4	^(a) 0.2A
(a)Minimum cable section: 0.75 mm ² ; maximum length: 5 m.			

Backup heater	Power supply	Required number of conductors
3kW	220-240V	3Wires
Minimum cable section: 4 mm ² ; maximum length: 5 m.		



NOTICE

More technical specifications of the different connections are indicated on the inside of the backup heater.

4 INSTALLATION

4.1 Opening the units

4.1.1 To open the backup heater

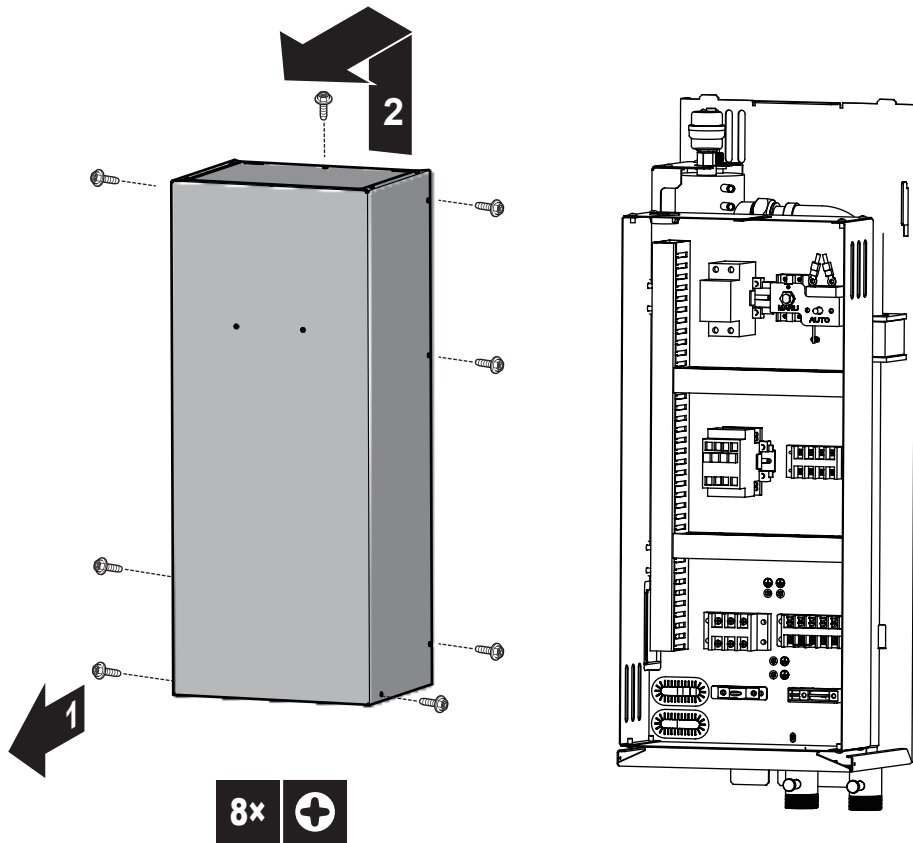

4.2 Mounting the backup heater

4.2.1 To install the backup heater

- 1 Fix the wall bracket to the wall with M8 screws. Mark the position of the hole at the bottom of the backup heater. Drill a hole for the bottom screw and insert a plug.

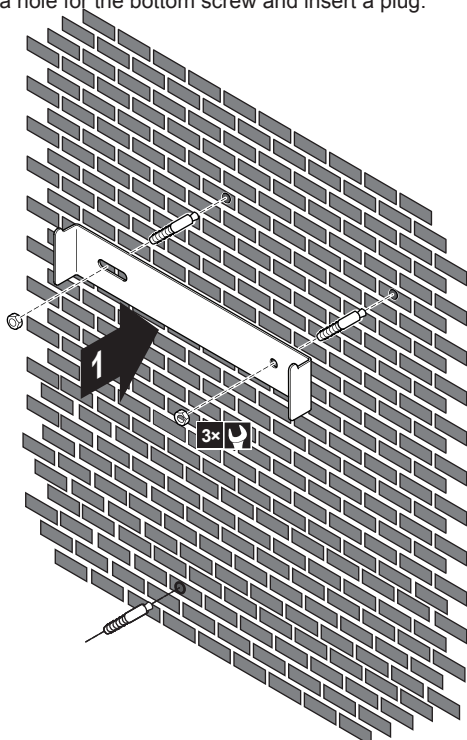

- 2 Fix the wall bracket to the backup heater with M4 screws.

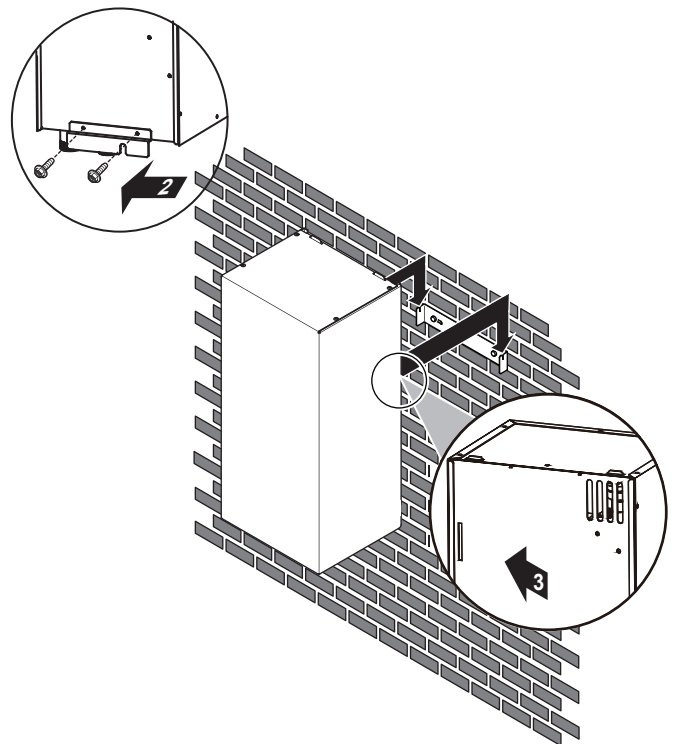

- 3 Hang the backup heater onto the wall bracket. Make sure it is fixed properly.
- 4 Fix the bottom of the backup heater to the wall with an M8 expansion screws.

4.3 Connecting the water piping

4.3.1 To connect the water piping



NOTICE

Do **NOT** use excessive force when connecting the piping. Deformation of the piping can cause malfunctioning of the unit.

- 1 Connect the water piping (field supply) to the water in and outlet of the backup heater.

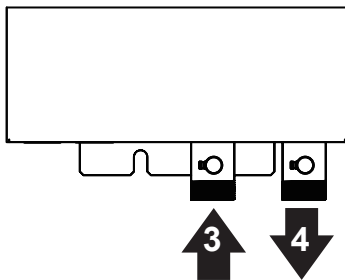

- 3 Water inlet
- 4 Water outlet

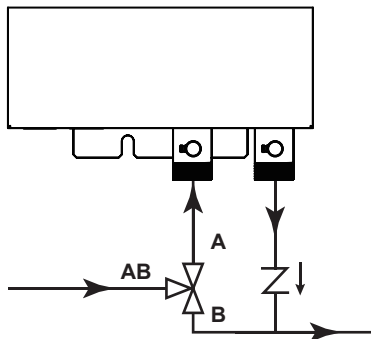

NOTICE

The function of the 3-way valve is to switch the water pipe. When we use the heat mode or hot water mode, the water flows AB to A; when we use the cool mode, the water flows AB to B.

When the outdoor unit is in cool mode, condensation may occur. Therefore provide a bypass by installing a valve kit to the water inlet of the backup heater. For instructions, refer to the installer reference guide. Do **NOT** install any other valve kit than the one specified in the installer reference guide.



INFORMATION

Inside the backup heater, an automatic air purge valve is installed. During operation, make sure the automatic air purge valve is open (at least 2 circles), remove air in the circuit as much as possible, air present in the water circuit might cause malfunctioning of the backup heater.

4.4 Connecting the electrical wiring



CAUTION

- The power supply should be an independent circuit with rated voltage.
- Power supply circuit should be earthed effectively.

The wiring must be performed by professional technicians in accordance with national wiring regulations and this circuit diagram.

- An all-pole disconnection device which has at least 3mm separation distance in all pole and a residual current device (RCD) with the rating of above 10mA shall be incorporated in the fixed wiring according to the national rule.
- Set the electric leakage protector electric technical standards of the state.
- The power cord and the signal cord and properly without mutual interference connection pipe or valve.
- After wire connection, check it again correctness before power on.
- If you want to rotate the electric box, please release the iron tie on the top of the E-box to avoid sensor's connection losing.

4.4.1 To connect the electrical wiring on the backup heater

Routing	Possible cables (depends on the installed options)
a High voltage	<ul style="list-style-type: none"> ▪ Main power supply ▪ Backup heater kit connection (to outdoor unit)
b Low voltage	<ul style="list-style-type: none"> ▪ Backup heater kit sensor (interconnection with outdoor unit)

- 1 Insert the wiring from the bottom of the backup heater.

- 2 Inside the backup heater, route the wiring as follows:

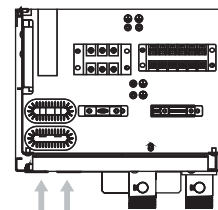

- a High voltage wiring
- b Low voltage wiring

- 3 Fix the wiring with cable ties to the cable tie mountings.



NOTICE

The distance between the high voltage and low voltage cables should be at least 25 mm.

4.4.2 To connect the backup heater power supply



CAUTION

To guarantee the unit is completely earthed, always connect the backup heater power supply and the earth cable.



WARNING

If a tank with a builtin electrical booster heater is part of the system, use a dedicated power circuit for the backup heater and booster heater.

NEVER use a power circuit shared by another appliance. This power circuit must be protected with the required safety devices according to the applicable legislation.

For the power supply, connect 3 wires to XT5/L+N+⊕

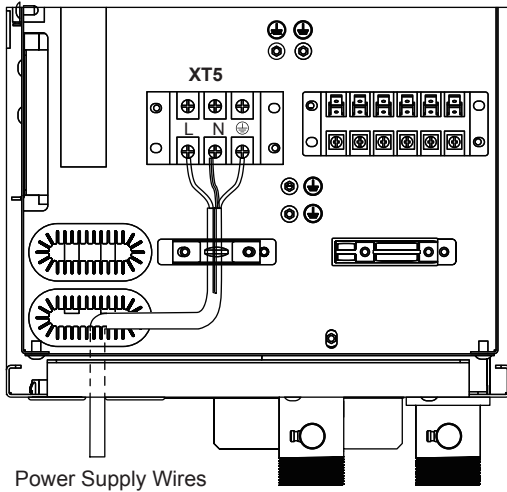

4.4.3 To connect the backup heater kit to the outdoor unit

For the sensor, connect 2 wires between backup heater terminals XT20M/5+6 and control box connector T1.

For the connection with the control box, connect 3 wires between backup heater terminals XT20/1+2 and control box terminals XT9/31+39.

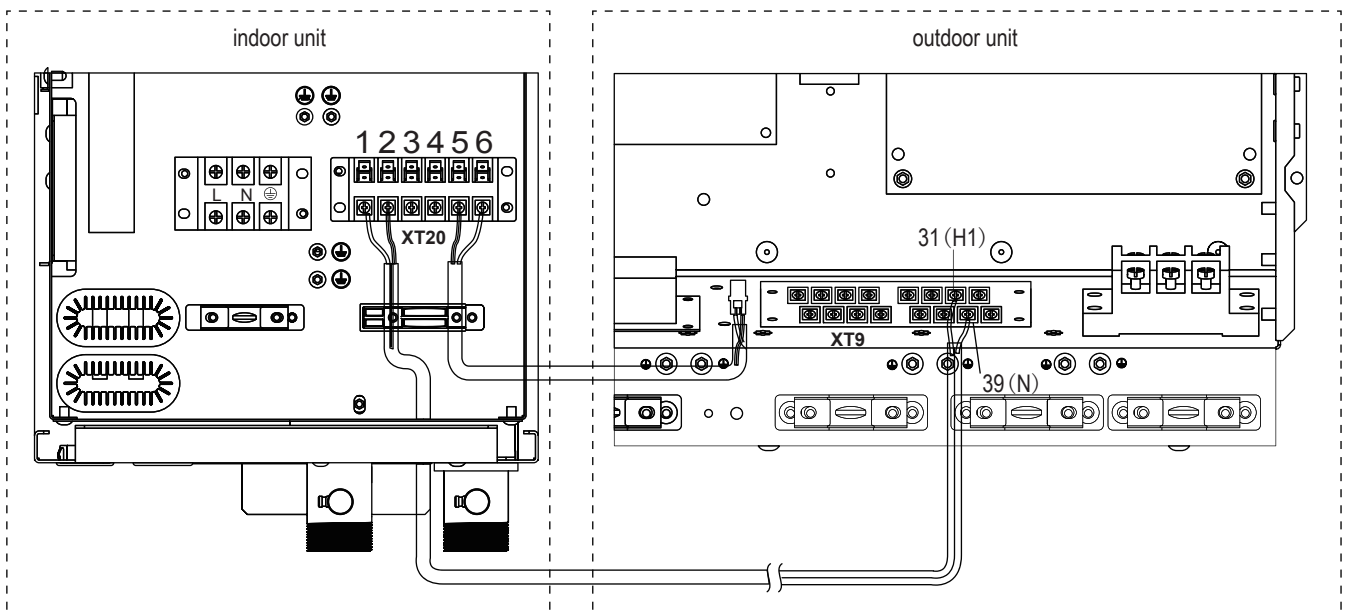

Fix the cable with cable ties to the cable tie mountings.



INFORMATION

- For details about the connections, refer to the wiring diagram.
- Use a multicore cable.

5 STARTING UP THE SYSTEM

For instructions on how to configure and commission the system, and hand it over to the user, refer to the installation manual of the outdoor unit.

6 MAIN PARAMETERS

6.1 Main parameters

main parameters		
Model		BH30A
Capacity		3.0kW
Rated current		13A
Power supply		220-240V~ 50Hz
Dimensions	Unit	780mm×220mm×280mm
	Packed unit	890mm×325mm×385mm
Weight	Unit	18.5kg
	Packed unit	24kg
Operation range		5~35℃
Pipe diameter	Water inlet/outlet	G1"

6.2 Water pressure drop

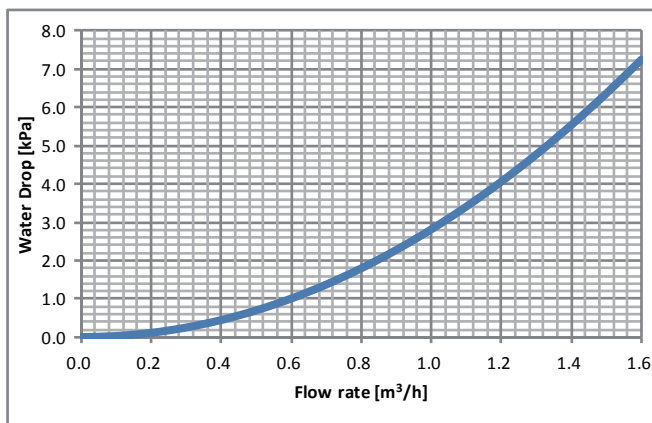

MD16IU-014BW

16110600000085