



Service Manual

TRIO DELTA 5.2

Indoor Units	Outdoor Units
DELTA 22	TRIO Delta 5.2 DCI
DELTA 25	
DELTA 35	



REFRIGERANT

R410A

HEAT PUMP

SM TRIO52 1-E.1 GB

OCTOBER – 2008

LIST OF EFFECTIVE PAGES

Note: Changes in the pages are indicated by a “Revision#” in the footer of each effected page (when none indicates no changes in the relevant page). All pages in the following list represent effected/ non effected pages divided by chapters.

Dates of issue for original and changed pages are:

Original 0 May 2006

Total number of pages in this publication is 56 consisting of the following:

Page No.	Revision No. #		Page No.	Revision No. #		Page No.	Revision No. #
----------	----------------	--	----------	----------------	--	----------	----------------

Title 1
 A 1
 i 1
 1-1 1
 2-1 - 2-4 1
 3-1 1
 4-1 - 4-2 1
 5-1 - 5-6 1
 6-1 - 6-6 1
 7-1 1
 8-1 1
 9-1 1
 10-1 1
 11-1-11-15 1
 12-1-12-6 1
 13-1-13-2 1
 Appendix -A 1

- Zero in this column indicates an original page.

*Due to constant improvements please note that the data on this service manual can be modified with out notice.

**Photos are not contractual

Table of Contents

1.	INTRODUCTION	1-1
2.	PRODUCT DATA SHEET	2-1
3.	RATING CONDITIONS	3-1
4.	OUTLINE DIMENSIONS	4-1
5.	PERFORMANCE DATA	5-1
6.	PRESSURE CURVES	6-1
7.	ELECTRICAL DATA.....	7-1
8.	WIRING DIAGRAMS	8-1
9.	REFRIGERATION DIAGRAMS	9-1
10.	TUBING CONNECTIONS.....	10-1
11.	CONTROL SYSTEM	11-1
12.	TROUBLESHOOTING	12-1
13.	EXPLODED VIEWS AND SPARE PARTS LISTS.....	13-1
14.	APPENDIX A	14-1

1. INTRODUCTION

1.1 General

The new **Trio 5.2 Delta DCI** Outdoor Unit is a high efficiency multi split inverter unit, supporting Indoor Units capacity range of - 2.2, 2.5 and 3.5 Kw.

1.2 Main Features

- DC Inverter
- R410A
- High COP (A class energy rating)
- Pre-Charged
- Base heater connection.
- Heating operation at outdoor temperature down to -15°C.
- 10 LED's, shows both indoor and outdoor diagnostics.
- Variable Speed DC Inverter outdoor fan.
- M2L diagnostics software cable Port (for PC).
- Low noise level

1.3 Tubing Connections

Flare type interconnecting tubing to be produced on site.
For further details please refer to APPENDIX A on this manual, and to the relevant indoor service Manual,

1.4 Inbox Documentation

Each indoor unit is supplied with its own installation and operation manuals.

1.5 Matching Table

1.5.1 R410A

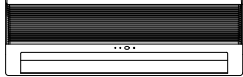
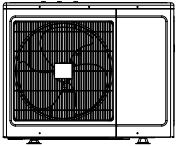
OUTDOOR UNITS		INDOOR UNITS			
					
	MODEL	REFRIGERANT	DELTA 22 DCI	DELTA 25 DCI	DELTA 35 DCI
	Trio 5.2 Delta DCI	R410A	√	√	√

2. PRODUCT DATA SHEET

2.1 Outdoor Unit TRIO 5.2 Delta Specifications.

Model			TRIO Delta 5.2kw DCI R410A		
Operation Mode			Cooling	Heating	
Capacity	Btu/hr		17747(2389~22184)	22525(3413~29914)	
	W		5200 (1000~6500)	6600(1000~7300)	
Total Input	W		1550(450~2150)	1800(450~1900)	
E.E.R (Cooling) / C.O.P (Heating)		W/W	3.35	3.67	
Energy efficiency class			A	A	
Running Current ⁽³⁾		A	6.7	7.8	
Starting Current		A	10.5		
Inrush Current		A	35.0		
Power Supply		V/Ph/Hz	Single Phase / 50Hz / 230V		
Dehumidification		L/h	1.7		
OUTDOOR UNIT	Refrigerant control		Electronic expansion valve		
	Compressor type		Scroll DC Inverter		
	Model		Panasonic 5CS130XCC03		
	Starter type		---		
	Protection device		Outdoor SW control		
	Heat exchanger		Hydrophilic flat fin, Grooved tube coil		
	Fan x No.		Propeller x 1		
	Airflow		m ³ /hr	2860	
	Motor output		W	70	
	Defrost method		Reverse cycle		
	Noise level ⁽⁴⁾	Pressure	dB(A)	50	56
		Power		63	67
	Dimensions	W*H*D	mm	846*690*302	
	Weight		Kg	48	
	Package	W*H*D	mm	990X770X430	
Unit stacking		#	3		
TUBING	Refrigerant Charge		Kg	R410A	
	Charge (7.5m connection tube)		g	1850	
	Fresh Air			NO	
	Tube size O.D.	Liquid	mm	6.35	
		Suction	mm	9.5	
	Connection method between the indoor and outdoor units	Indoor & outdoor		Flared	
		Height difference between indoor units		Max.5m	
		Height difference between indoor & outdoor		Max.5m	
		Tubing length		Standard 7.5m Max. 25m for one unit and 35m for total	
		Additional charge		No need	

2.2 Indoor Units Data

2.2.1 DELTA 22 DCI Specifications

Model Indoor Unit / Type				DELTA 22 DCI / Wall Mounted		
Installation Method				FLARE		
Power Supply		V/Ph/Hz		220-240 / 1/ 50		
INDOOR	Fan Type & Quantity			Crossflow *1		
	Airflow ⁽²⁾ Cooling / Heating	H/M/L	m ³ /hr	400	350	300
	Sound Power Level ⁽³⁾ Cooling / Heating	L - H	dB (A)	49/46/43		
	Sound Pressure Level ⁽⁴⁾ Cooling / Heating	L - H	dB (A)	36/33/30		
	Condensate Drain Tube I.D.		mm	16		
	Dimensions	W/H/D	mm	680	250	185
	Weight		kg	7		
	Package Dimensions	W/H/D	mm	740	320	265
	Stacking Height		Units	9 LEVELS		
	Heating Elements		kW	N/A		
Moisture Removal		L/hr	1			

2.2.2 DELTA 25 DCI Specifications

Model Indoor Unit / Type				DELTA 25 DCI / Wall Mounted		
Installation Method				FLARE		
Power Supply		V/Ph/Hz		220-240 / 1/ 50		
INDOOR	Fan Type & Quantity			Crossflow *1		
	Airflow ⁽²⁾ Cooling / Heating	H/M/L	m ³ /hr	420	350	270
	Sound Power Level ⁽³⁾ Cooling / Heating	L - H	dB (A)	52/48/45		
	Sound Pressure Level ⁽⁴⁾ Cooling / Heating	L - H	dB (A)	39/35/32		
	Condensate Drain Tube I.D.		mm	16		
	Dimensions	W/H/D	mm	680	250	185
	Weight		kg	7		
	Package Dimensions	W/H/D	mm	740	320	260
	Stacking Height		Units	9 LEVELS		
	Heating Elements		kW	N/A		
Moisture Removal		L/hr	1.0			

- (1) Rating conditions in accordance with ISO 5151 and ISO 13253 (for ducted units) and EN14511.
- (2) Airflow in ducted units; at nominal external static pressure.
- (3) Sound power in ducted units is measured at air discharge.
- (4) Sound pressure level measured at 1 meter distance from unit.

2.2.3 DELTA 35 DCI Specifications

Model Indoor Unit / Type				DELTA 35 DCI / Wall Mounted		
Installation Method				FLARE		
Power Supply		V/Ph/Hz		220-240 / 1/ 50		
INDOOR	Fan Type & Quantity			Crossflow *1		
	Airflow ⁽²⁾ Cooling / Heating	H/M/L	m ³ /hr	550	450	350
	Sound Power Level ⁽³⁾ Cooling / Heating	L - H	dB (A)	56/46/42		
	Sound Pressure Level ⁽⁴⁾ Cooling / Heating	L - H	dB (A)	39/33/29		
	Condensate Drain Tube I.D.		mm	16		
	Dimensions	W/H/D	mm	840	250	185
	Weight		kg	8.0		
	Package Dimensions	W/H/D	mm	930	320	265
	Stacking Height		Units	9 LEVELS		
	Heating Elements		kW	N/A		
Moisture Removal		L/hr	1.5			

(1) Rating conditions in accordance with ISO 5151 and ISO 13253 (for ducted units) and EN14511.

(2) Airflow in ducted units; at nominal external static pressure.

(3) Sound power in ducted units is measured at air discharge.

(4) Sound pressure level measured at 1 meter distance from unit.

2.3 Indoor Units Combinations

2.3.1 Cooling

Model	Cooling Capacity [W]				Total Power[W]
	A	B	C	Total Capacity	
22	2200	-	-	2200(1050-2600)	645(450-750)
25	2500	-	-	2500(1100-3500)	740(510-1040)
35	3500	-	-	3500(1200-4200)	1020(510-1250)
22+22	2000	2000	-	4000(1400-5100)	1170(520-1500)
22+25	2000	2150	-	4150(1450-5200)	1220(530-1530)
22+35	2000	3000	-	5000(1720-6200)	1450(610-1910)
25+25	2150	2150	-	4300(1710-6200)	1250(610-1910)
25+35	2150	3000	-	5150(1710-6280)	1510(600-1930)
35+35	3000	3000	-	6000(1800-6400)	1720(635-2110)
22+22+22	1700	1700	1700	5100(1860-6420)	1500(636-2000)
22+22+25	1700	1700	1730	5130(1870-6420)	1510(636-2000)
22+22+35	1700	1700	2600	6000(1870-6450)	1720(635-2110)
22+25+25	1700	1730	1730	5160(1870-6450)	1500(635-2110)
22+25+35	1700	1730	2600	6030(1880-6450)	1730(640-2115)
25+25+25	1730	1730	1740	5200(1860-6440)	1550(640-2020)
25+25+35	1730	1730	2600	6060(1880-6500)	1740(640-2130)

2.3.2 Heating

Model	Heating Capacity [W]				Total Power[W]
	A	B	C	Total Capacity	
22	2600	-	-	2600(1200-3000)	708(450-800)
25	3000	-	-	3000(1200-3500)	795(450-920)
35	4200	-	-	4200(1200-4500)	1080(510-1160)
22+22	2500	2500	-	5000(1600-6000)	1280(460-1560)
22+25	2500	2650	-	5150(1600-6150)	1300(460-1560)
22+35	2500	3350	-	5850(2000-7100)	1420(510-1920)
25+25	2650	2650	-	5300(1800-6500)	1350(480-1600)
25+35	2650	3350	-	6000(2000-7100)	1450(510-1920)
35+35	3350	3350	-	6700(2100-7150)	1700(515-1930)
22+22+22	2100	2100	2100	6300(2100-7220)	1665(525-1980)
22+22+25	2100	2100	2200	6400(2100-7250)	1670(525-1980)
22+22+35	2100	2100	3020	7220(2120-7260)	1870(530-2000)
22+25+25	2100	2200	2200	6500(2120-7260)	1680(635-2000)
22+25+35	2100	2200	3020	7320(2130-7560)	1660(640-2105)
25+25+25	2200	2200	2200	6600(2120-7260)	1800(640-2000)
25+25+35	2200	2200	3020	7420(2200-7600)	1910(640-2110)

3. RATING CONDITIONS

Standard conditions in accordance with ISO 5151, ISO 13253 (for ducted units) and EN 14511.

Cooling:

Indoor: 27°C DB 19°C WB

Outdoor: 35°C DB

Heating:

Indoor: 20°C DB

Outdoor: 7°C DB 6°C WB

3.1 Operating Limits

		Indoor	Outdoor
Cooling	Upper limit	32°C DB 23°C WB	46°C DB
	Lower limit	21°C DB 15°C WB	10°C DB
Heating	Upper limit	27°C DB	24°C DB 18°C WB
	Lower limit	10°C DB	-15°C DB -16°C WB
Voltage	1PH	198 – 264 V	
	3PH	N/A	

4. OUTLINE DIMENSIONS

4.1 Indoor Unit: DELTA 22 / 25 DCI

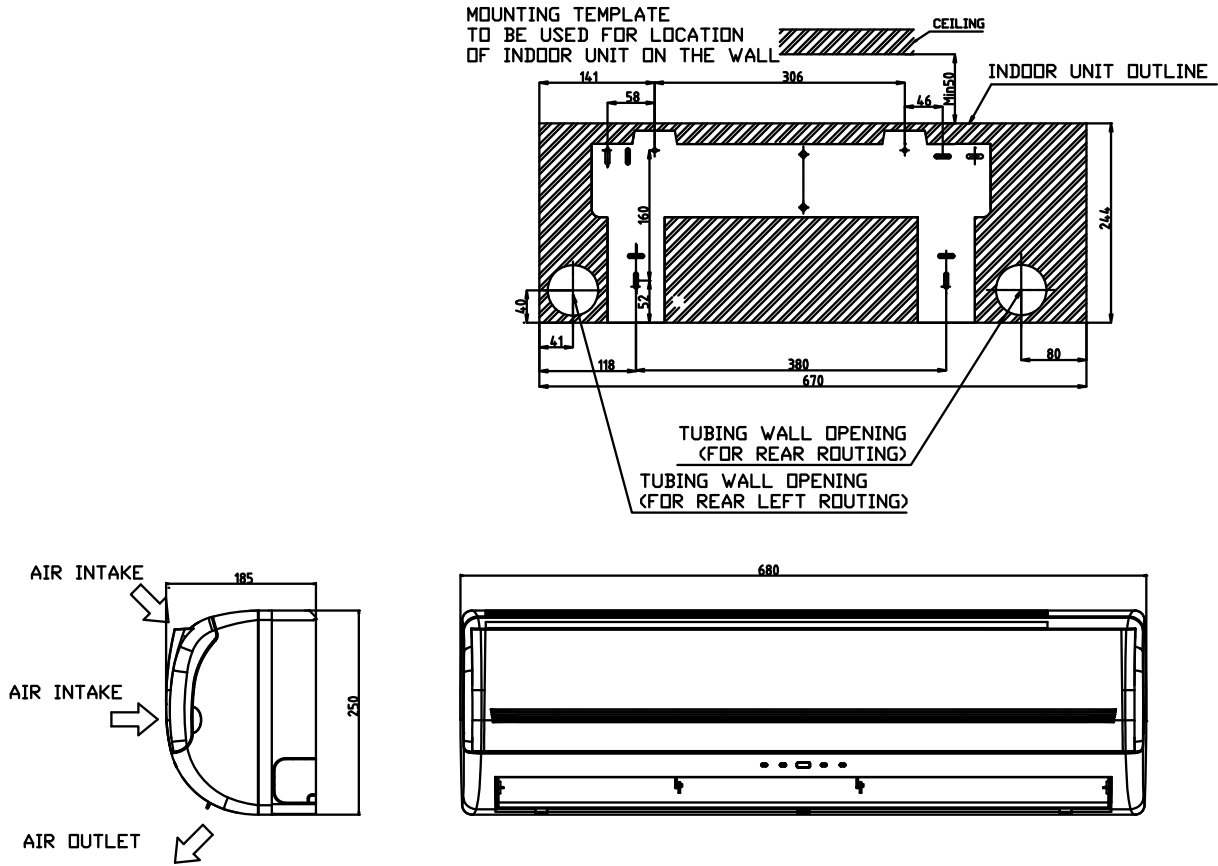

4.2 Indoor Unit: DELTA 35 DCI

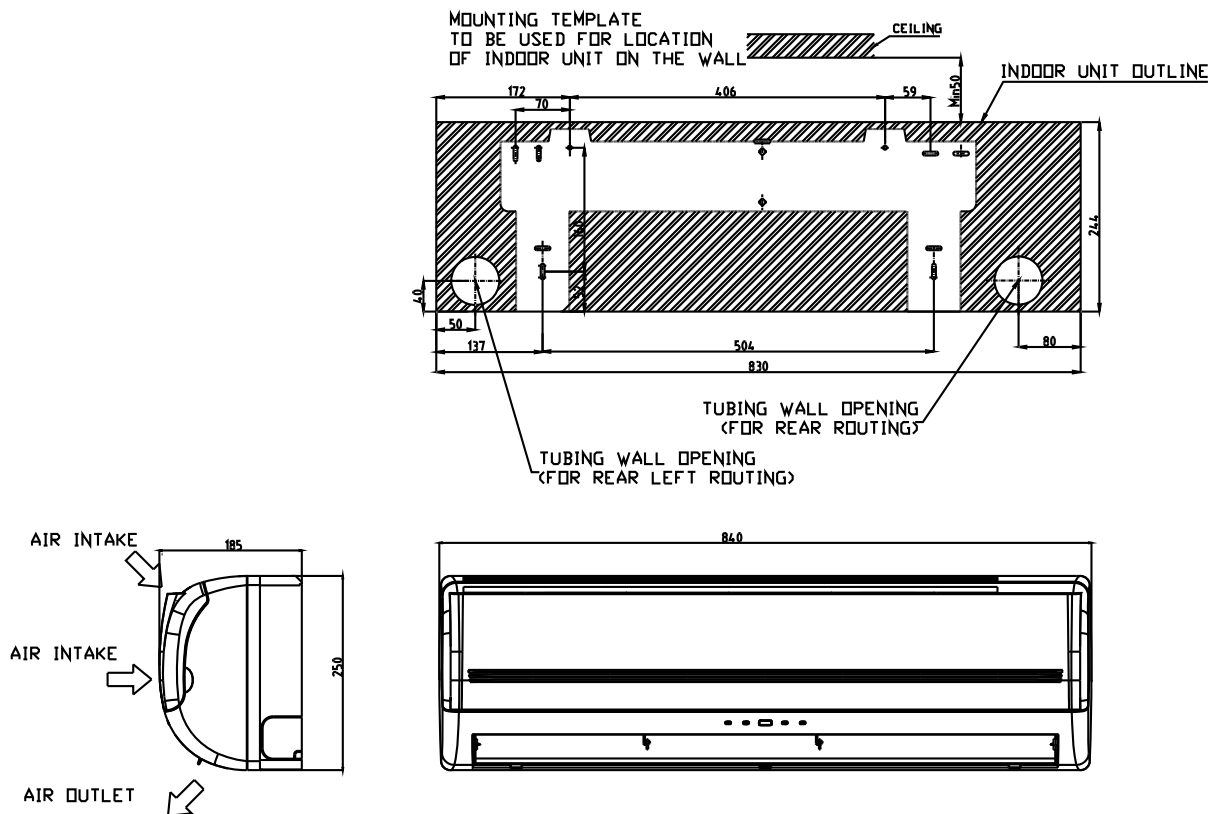

4.3 Outdoor Unit: Trio Delta 5.2 DCI

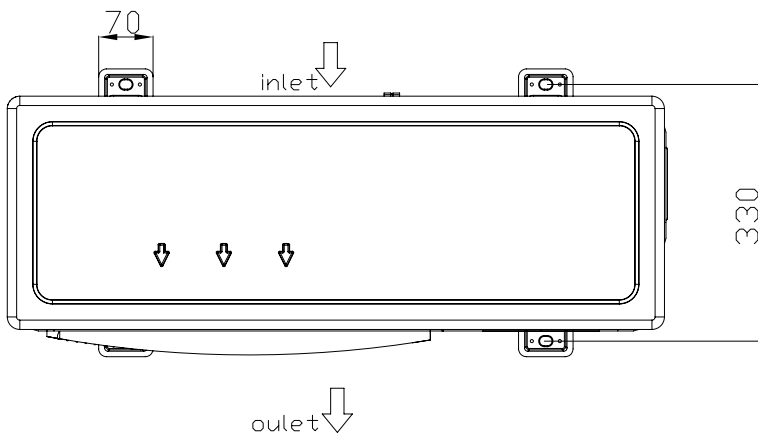
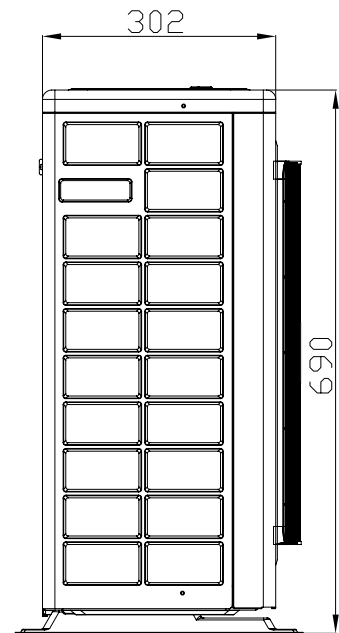
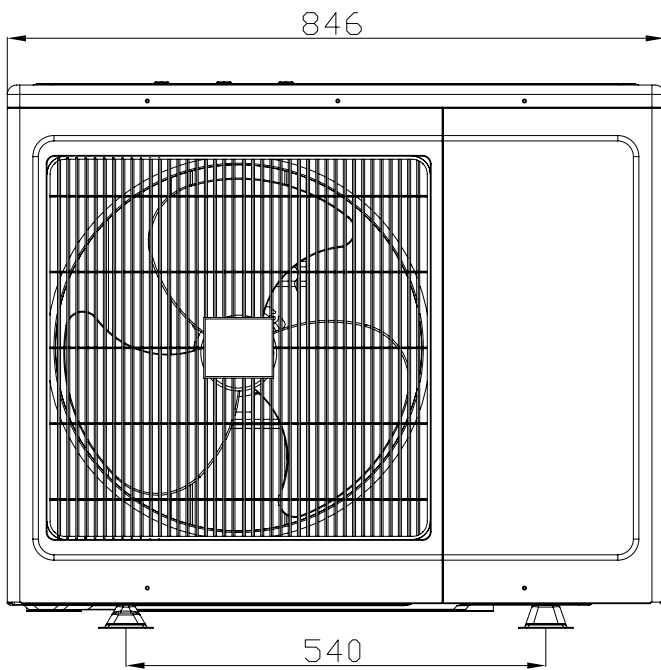

Dimension
Unit: mm

5. PERFORMANCE DATA

5.1 TRIO DELTA 25+25+25

5.1.1 Cooling Capacity (kW) - Run Mode

230[V] : Indoor Fan at High Speed.

OD COIL ENTERING AIR DB TEMPERATURE [C°]	DATA	ID COIL ENTERING AIR DB/WB TEMPERATURE [C°]				
		22/15	24/17	27/19	29/21	32/23
-10 - 20 (protection range)	TC	80 - 110 % of nominal				
	SC	80 - 105 % of nominal				
	PI	25 - 50 % of nominal				
25	TC	5.58	5.90	6.23	6.56	6.88
	SC	4.84	4.95	5.07	5.19	5.30
	PI	1.22	1.24	1.27	1.29	1.32
30	TC	5.06	5.39	5.71	6.04	6.37
	SC	4.59	4.71	4.82	4.94	5.05
	PI	1.36	1.38	1.41	1.43	1.46
35	TC	4.55	4.87	5.20	5.53	5.85
	SC	4.35	4.46	4.58	4.69	4.81
	PI	1.50	1.52	1.55	1.58	1.60
40(Protection Range)	TC	80%-92% of nominal				
	SC	80%-92% of nominal				
	PI	80%-92% of nominal				
46(Protection Range)	TC	70%-85% of nominal				
	SC	70%-85% of nominal				
	PI	90%-100% of nominal				

LEGEND

- TC – Total Cooling Capacity, kW
- PI – Power Input, kW
- WB – Wet Bulb Temp., (°C)
- DB – Dry Bulb Temp., (°C)
- ID – Indoor
- OD – Outdoor
- SC – Sensible Capacity, kW

5.1.2 Capacity Correction Factors

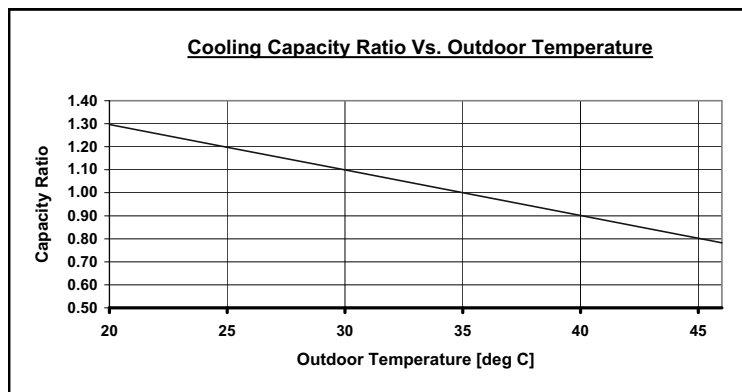

5.1.3 Heating Capacity (kW) - Run Mode

230[V] : Indoor Fan at High Speed.

		ID COIL ENTERING AIR DB TEMPERATURE [C°]		
OD COIL ENTERING AIR DB/WB TEMPERATURE [C°]	DATA	15	20	25
-15/-16	TC	3.52	3.30	3.08
	PI	1.15	1.32	1.48
-10/-12	TC	4.21	3.99	3.78
	PI	1.33	1.49	1.66
-7/-8	TC	4.73	4.52	4.30
	PI	1.46	1.62	1.79
-1/-2	TC	5.00	4.78	4.56
	PI	1.52	1.69	1.86
2/1	TC	5.17	4.95	4.73
	PI	1.57	1.73	1.90
7/6	TC	6.82	6.60	6.38
	PI	1.63	1.80	1.97
10/9	TC	7.09	6.87	6.65
	PI	1.71	1.88	2.04
15/12	TC	7.36	7.14	6.92
	PI	1.79	1.95	2.12
15-24 (Protection Range)	TC	85 - 105 % of nominal		
	PI	80 - 120 % of nominal		

LEGEND

- TC – Total Heating Capacity, kW
- PI – Power Input, kW
- WB – Wet Bulb Temp., (°C)
- DB – Dry Bulb Temp., (°C)
- ID – Indoor
- OU – Outdoor

5.1.4 Capacity Correction Factors

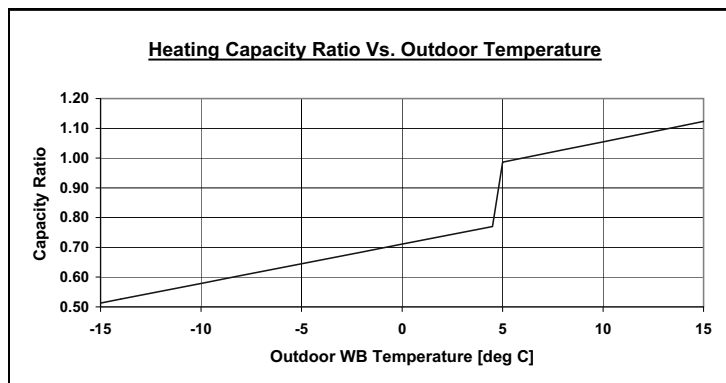

5.2 Delta Trio 25+25+35

5.2.1 Cooling Capacity (kW) - Run Mode

230[V] : Indoor Fan at High Speed.

OD COIL ENTERING AIR DB TEMPERATURE [C°]		DATA	ID COIL ENTERING AIR DB/WB TEMPERATURE [C°]				
			22/15	24/17	27/19	29/21	32/23
-10 - 20 (protection range)	TC	80 - 110 % of nominal					
	SC	80 - 105 % of nominal					
	PI	25 - 50 % of nominal					
25	TC	6.50	6.88	7.26	7.64	8.02	
	SC	5.64	5.77	5.91	6.04	6.18	
	PI	1.37	1.40	1.42	1.45	1.48	
30	TC	5.90	6.28	6.66	7.04	7.42	
	SC	5.35	5.49	5.62	5.76	5.89	
	PI	1.53	1.55	1.58	1.61	1.64	
35	TC	5.30	5.68	6.06	6.44	6.82	
	SC	5.06	5.20	5.33	5.47	5.60	
	PI	1.68	1.71	1.74	1.77	1.80	
40(Protection Range)	TC	80%-92% of nominal					
	SC	80%-92% of nominal					
	PI	80%-92% of nominal					
46(Protection Range)	TC	70%-85% of nominal					
	SC	70%-85% of nominal					
	PI	90%-100% of nominal					

LEGEND

- TC – Total Cooling Capacity, kW
- PI – Power Input, kW
- WB – Wet Bulb Temp., (°C)
- DB – Dry Bulb Temp., (°C)
- ID – Indoor
- OD – Outdoor
- SC – Sensible Capacity, kW

5.2.2 Capacity Correction Factors

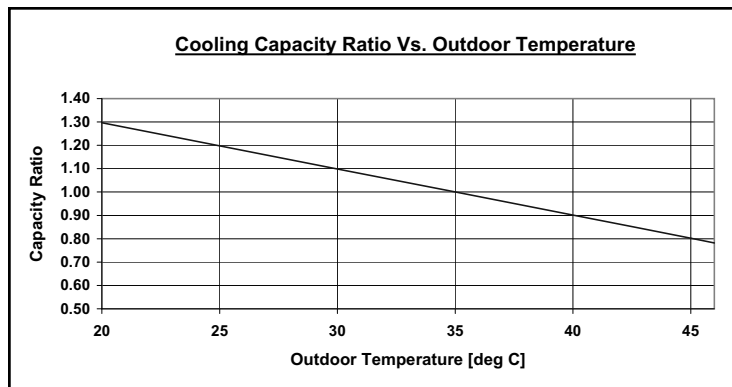

5.2.3 Heating Capacity (kW) - Run Mode
230[V] : Indoor Fan at High Speed.

OD COIL ENTERING AIR DB/WB TEMPERATURE [C°]	DATA	ID COIL ENTERING AIR DB TEMPERATURE [C°]		
		15	20	25
-15/-16	TC	3.95	3.71	3.46
	PI	1.22	1.40	1.57
-10/-12	TC	4.74	4.49	4.25
	PI	1.41	1.58	1.76
-7/-8	TC	5.32	5.08	4.83
	PI	1.55	1.72	1.90
-1/-2	TC	5.62	5.37	5.13
	PI	1.62	1.79	1.97
2/1	TC	5.81	5.57	5.32
	PI	1.66	1.84	2.02
7/6	TC	7.66	7.42	7.18
	PI	1.73	1.91	2.09
10/9	TC	7.97	7.73	7.48
	PI	1.82	1.99	2.17
15/12	TC	8.27	8.03	7.79
	PI	1.90	2.07	2.25
15-24 (Protection Range)	TC	85 - 105 % of nominal		
	PI	80 - 120 % of nominal		

LEGEND

- TC – Total Heating Capacity, kW
- PI – Power Input, kW
- WB – Wet Bulb Temp., (°C)
- DB – Dry Bulb Temp., (°C)
- ID – Indoor
- OU – Outdoor

5.2.4 Capacity Correction Factors

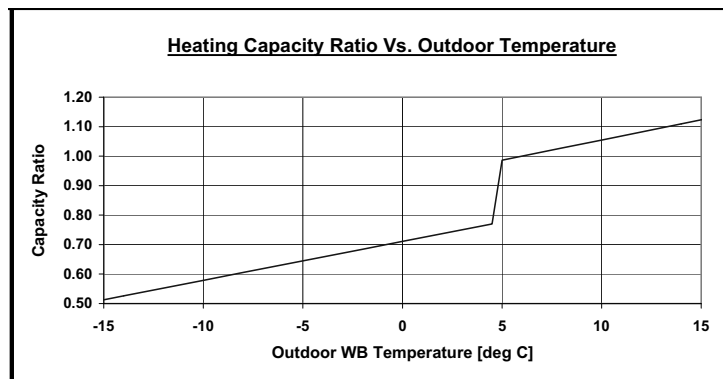

5.3 Delta Trio 35+35

5.3.1 Cooling Capacity (kW) - Run Mode

230[V] : Indoor Fan at High Speed.

OD COIL ENTERING AIR DB TEMPERATURE [C°]		ID COIL ENTERING AIR DB/WB TEMPERATURE [C°]				
		22/15	24/17	27/19	29/21	32/23
-10 - 20 (protection range)	TC	80 - 110 % of nominal				
	SC	80 - 105 % of nominal				
	PI	25 - 50 % of nominal				
25	TC	6.44	6.81	7.19	7.56	7.94
	SC	5.58	5.72	5.85	5.98	6.12
	PI	1.35	1.38	1.41	1.43	1.46
30	TC	5.84	6.22	6.59	6.97	7.35
	SC	5.30	5.43	5.57	5.70	5.83
	PI	1.51	1.54	1.56	1.59	1.62
35	TC	5.25	5.62	6.00	6.38	6.75
	SC	5.01	5.15	5.28	5.41	5.55
	PI	1.66	1.69	1.72	1.75	1.78
40(Protection Range)	TC	80%-92% of nominal				
	SC	80%-92% of nominal				
	PI	80%-92% of nominal				
46(Protection Range)	TC	70%-85% of nominal				
	SC	70%-85% of nominal				
	PI	90%-100% of nominal				

LEGEND

- TC – Total Cooling Capacity, kW
- PI – Power Input, kW
- WB – Wet Bulb Temp., (°C)
- DB – Dry Bulb Temp., (°C)
- ID – Indoor
- OD – Outdoor
- SC – Sensible Capacity, kW

5.3.2 Capacity Correction Factors

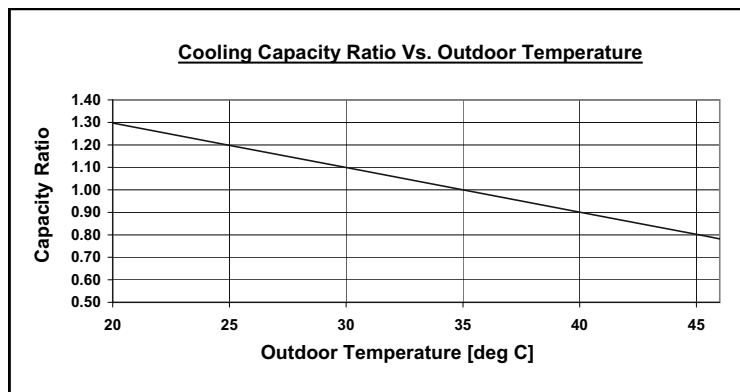

5.3.3 Heating Capacity (kW) - Run Mode)

230[V] : Indoor Fan at High Speed.

		ID COIL ENTERING AIR DB TEMPERATURE [C°]		
OD COIL ENTERING AIR DB/WB TEMPERATURE [C°]	DATA	15	20	25
-15/-16	TC	3.57	3.35	3.13
	PI	1.09	1.24	1.40
-10/-12	TC	4.28	4.05	3.83
	PI	1.25	1.41	1.57
-7/-8	TC	4.81	4.59	4.36
	PI	1.38	1.53	1.69
-1/-2	TC	5.07	4.85	4.63
	PI	1.44	1.60	1.75
2/1	TC	5.25	5.03	4.81
	PI	1.48	1.64	1.79
7/6	TC	6.92	6.70	6.48
	PI	1.54	1.70	1.86
10/9	TC	7.20	6.98	6.75
	PI	1.62	1.77	1.93
15/12	TC	7.47	7.25	7.03
	PI	1.69	1.84	2.00
15-24 (Protection Range)	TC	85 - 105 % of nominal		
	PI	80 - 120 % of nominal		

LEGEND

- TC – Total Heating Capacity, kW
- PI – Power Input, kW
- WB – Wet Bulb Temp., (°C)
- DB – Dry Bulb Temp., (°C)
- ID – Indoor
- OU – Outdoor

5.3.4 Capacity Correction Factors

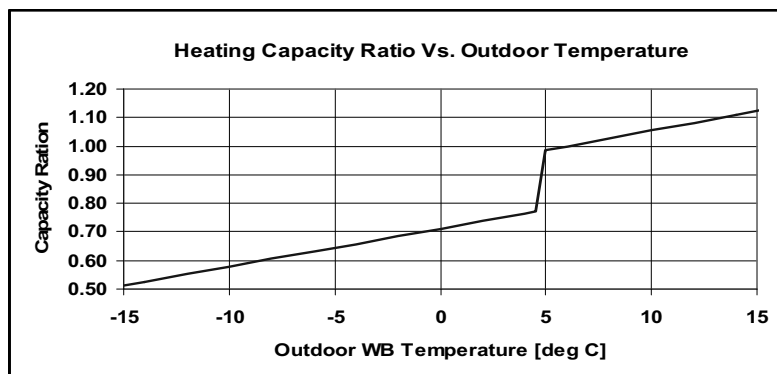

5.4 Capacity Correction Factor Due to Tubing Length (OneWay)

5.4.1 Delta 22 / 25 / 35 DCI

5.4.2 Cooling

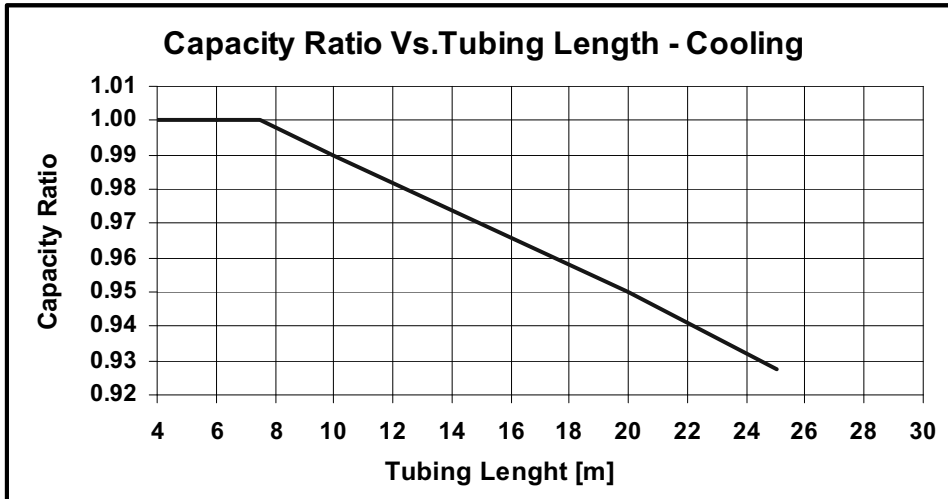

5.4.3 Heating

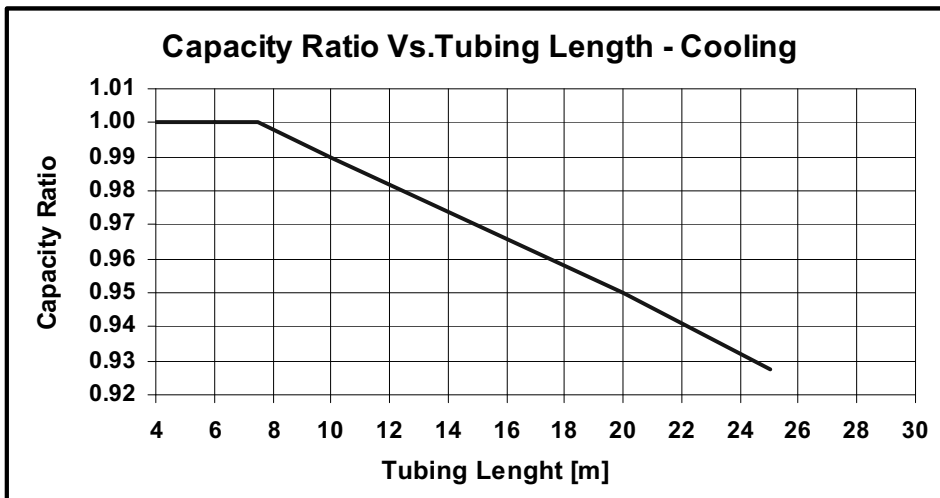

6. PRESSURE CURVES

6.1 Model: Trio Delta 25+25+25

6.1.1 Cooling – Test Mode

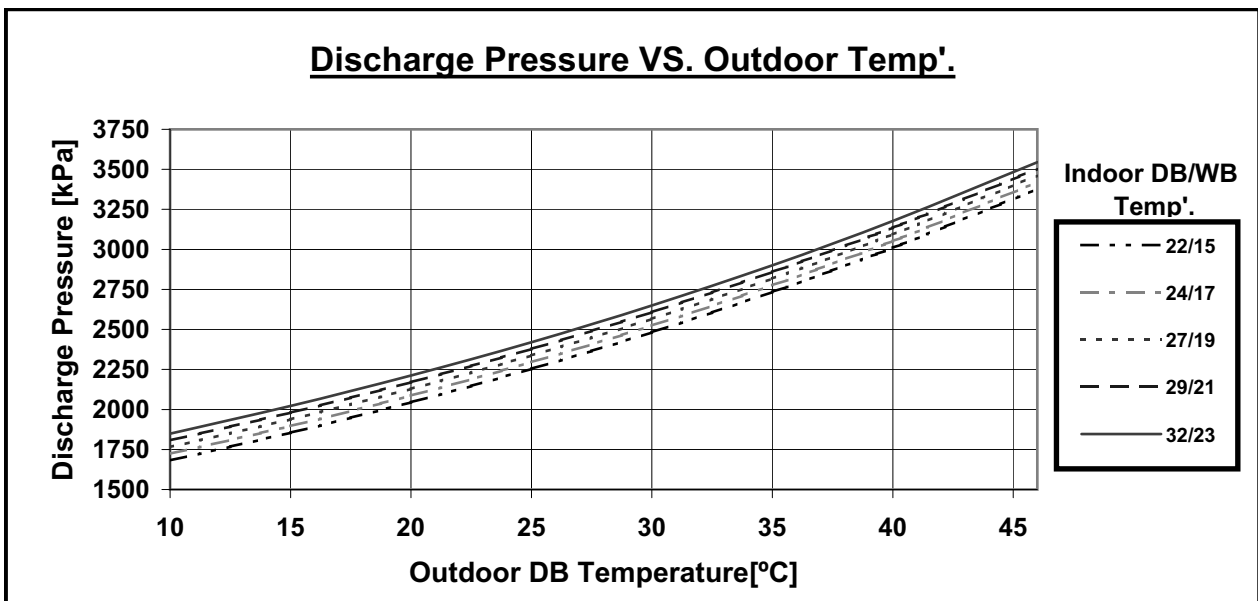
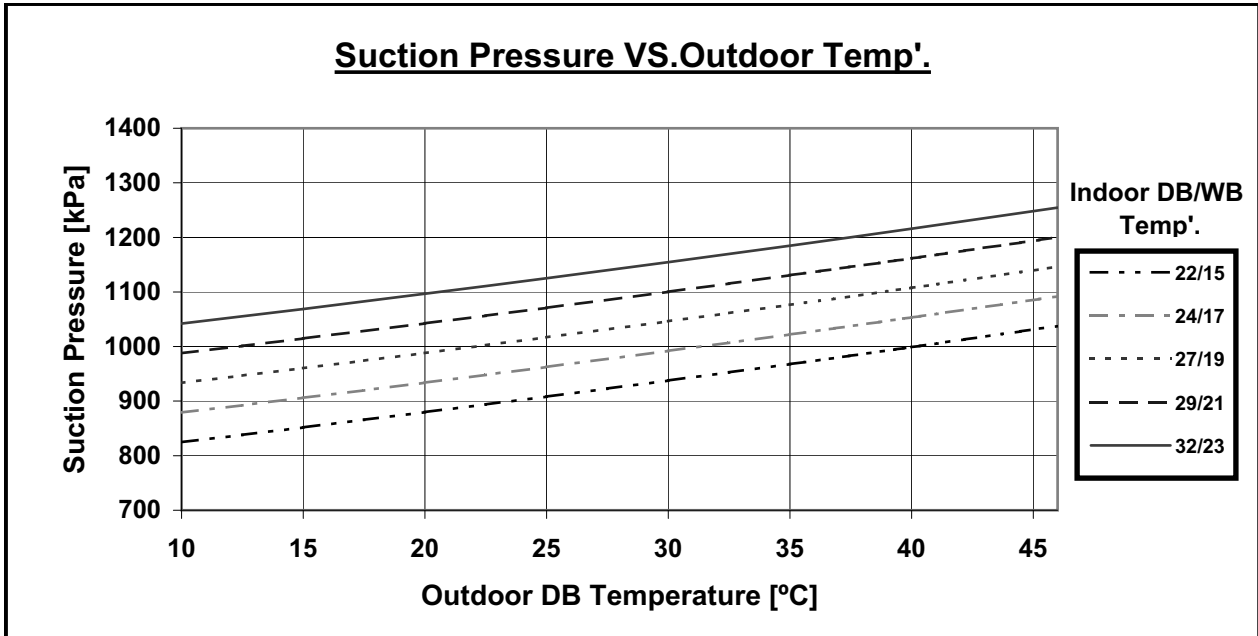

6.1.2 Heating – Test Mode

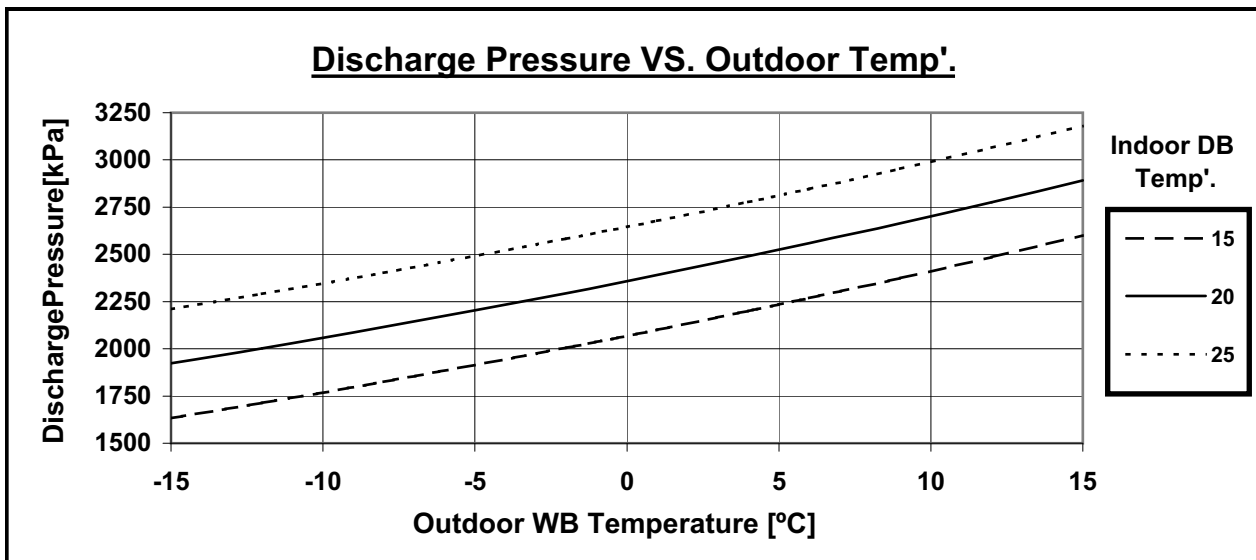
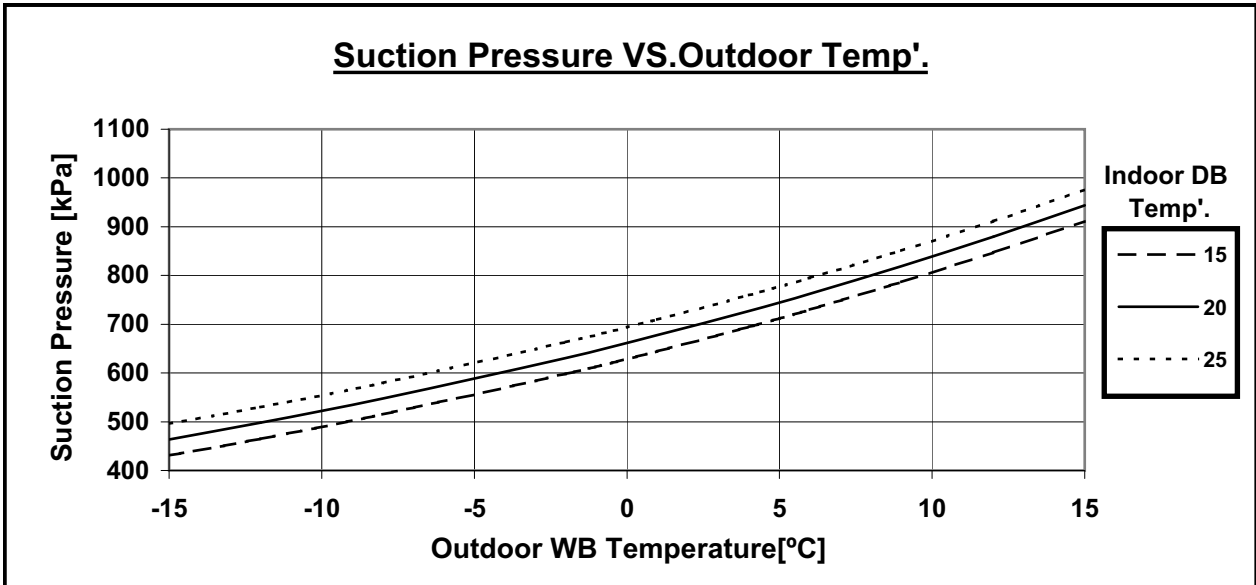

6.2 Model: Trio Delta 25+25+35

6.2.1 Cooling - Test Mode

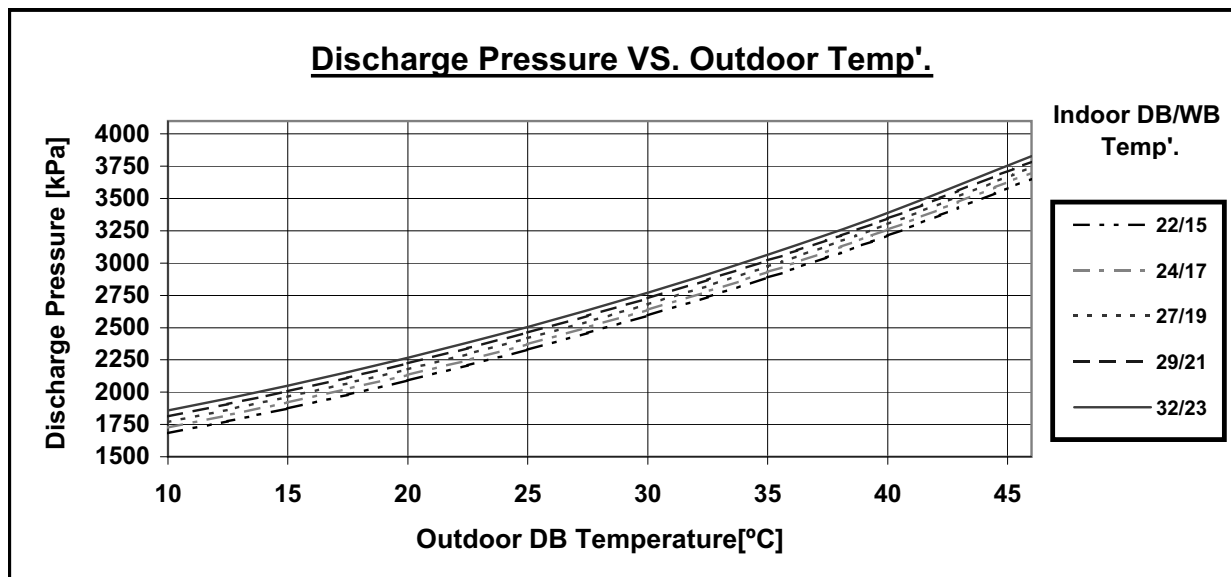
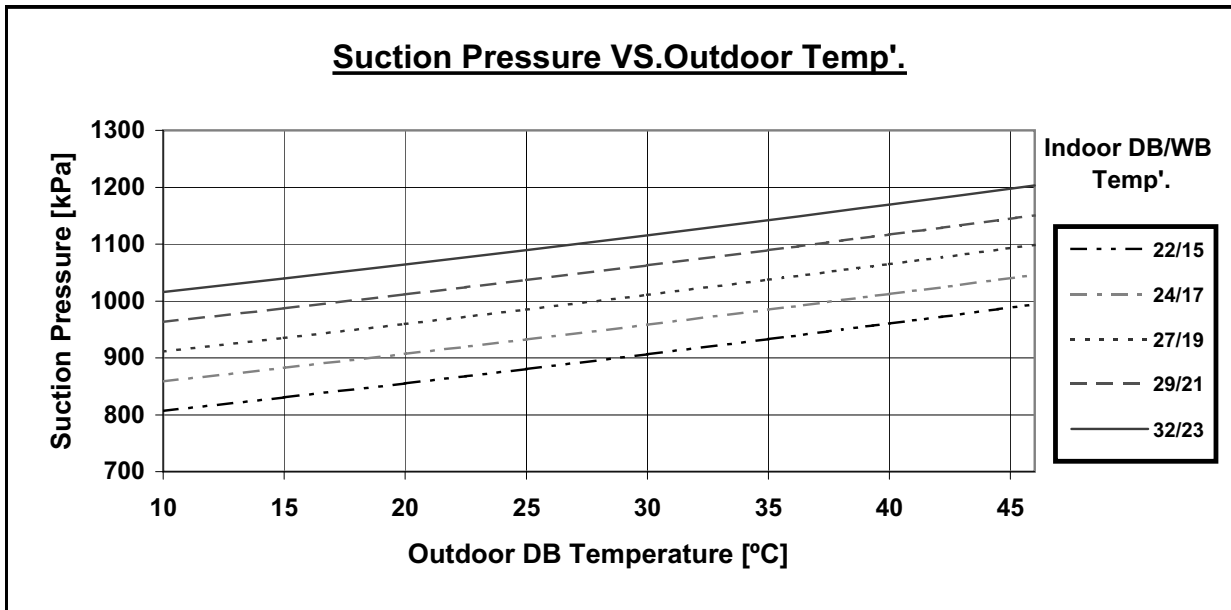

6.2.2 Heating – Test Mode

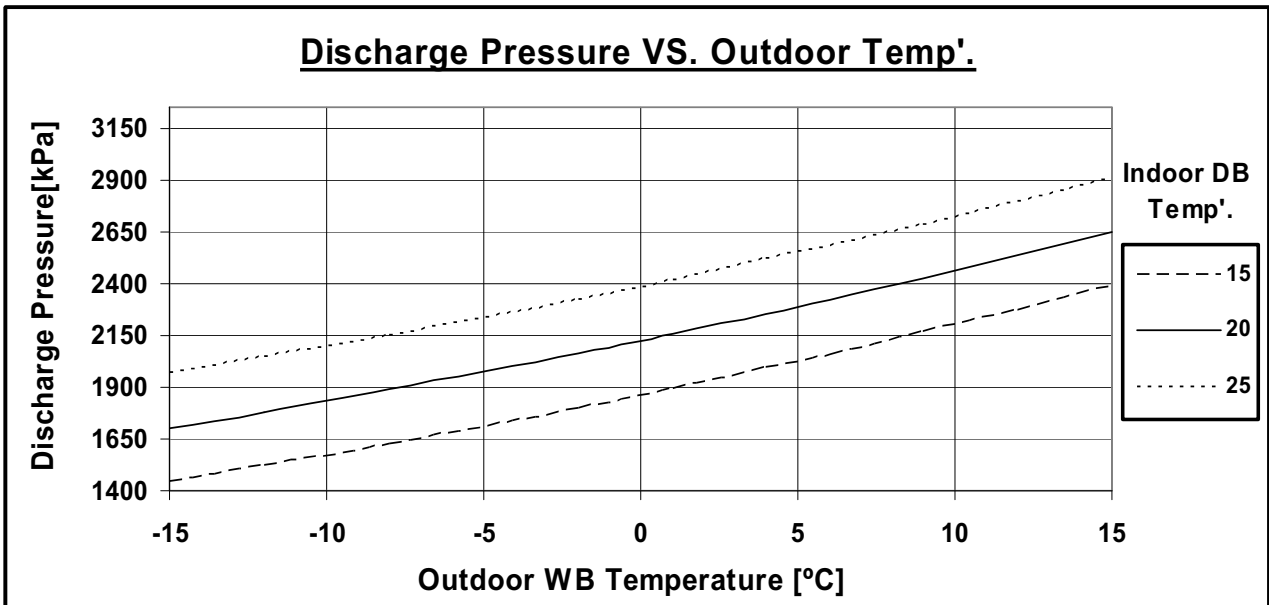
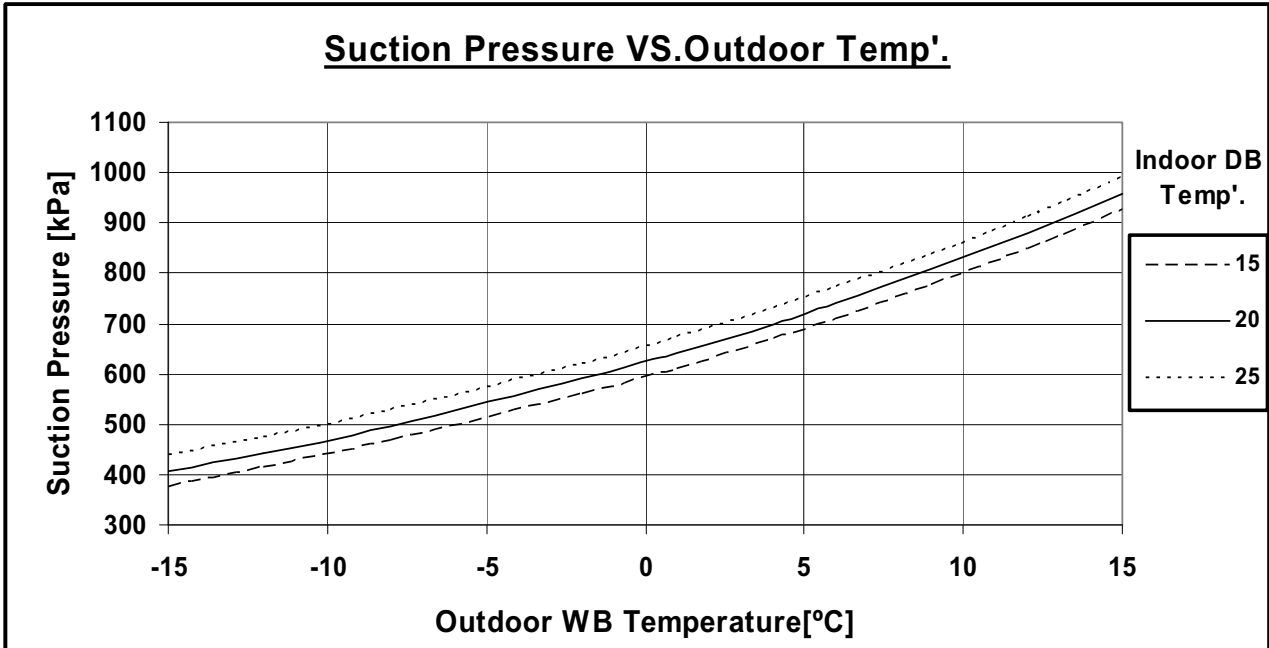

6.3 Model: Trio Delta 35+35

6.3.1 Cooling - Test Mode

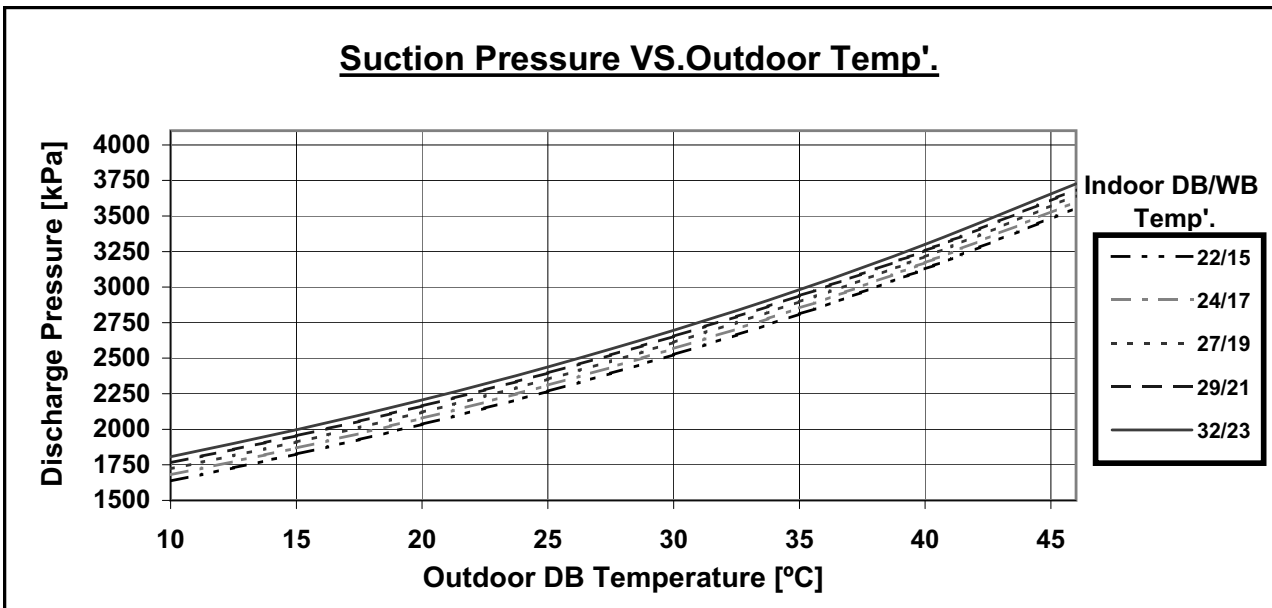
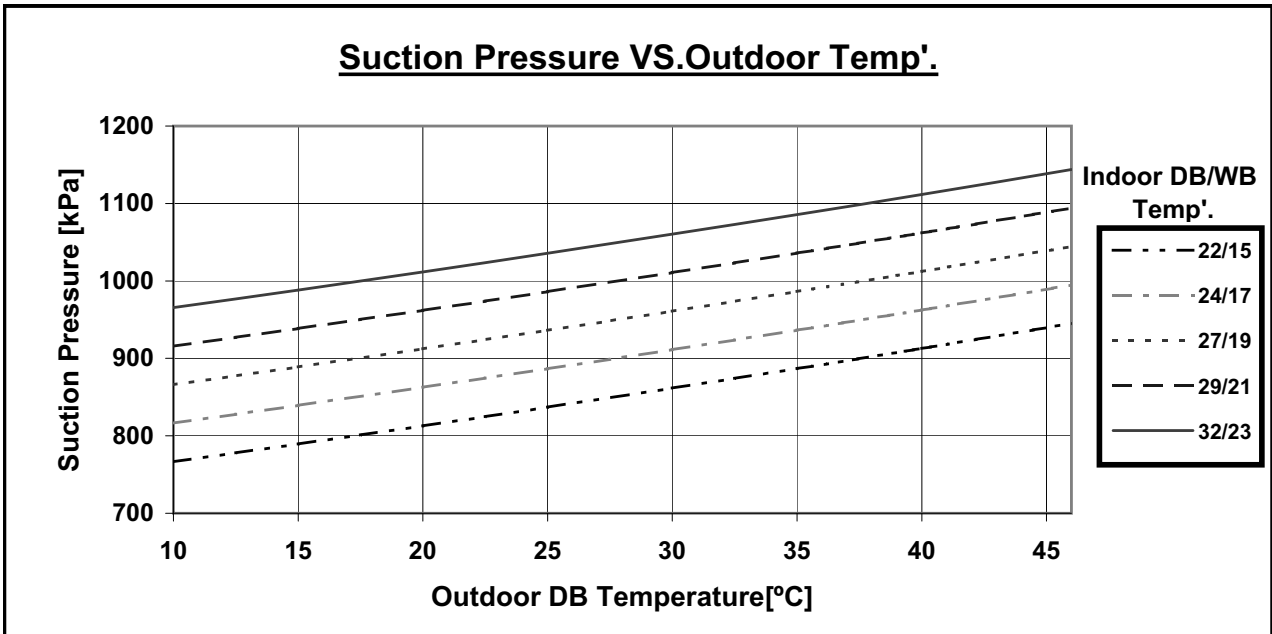

6.3.2 Heating – Test Mode

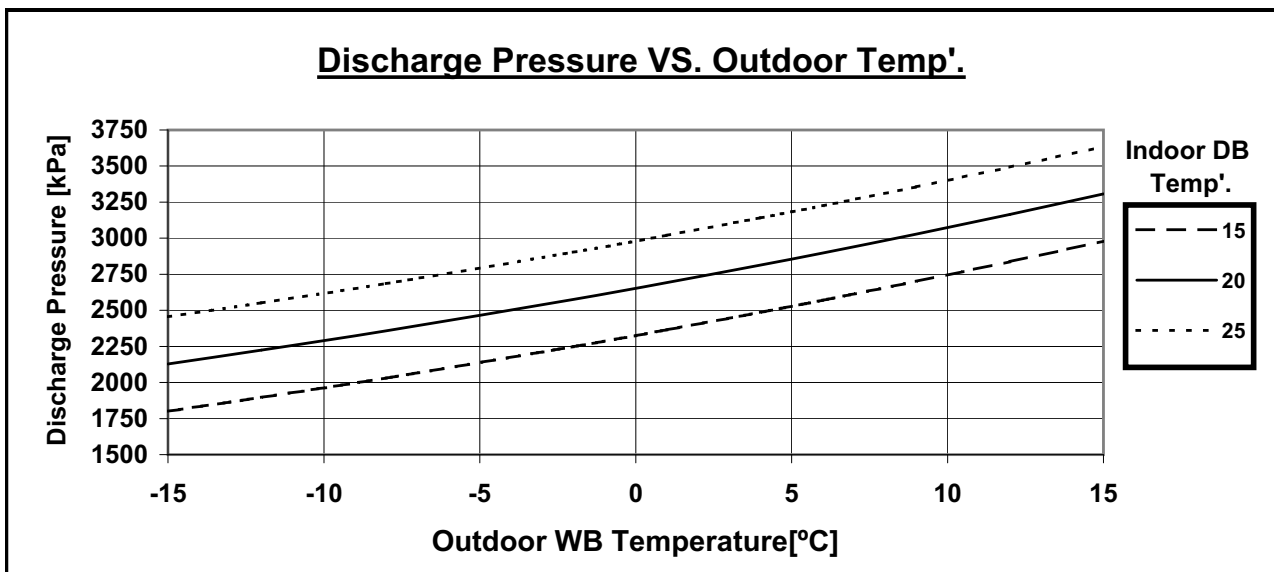
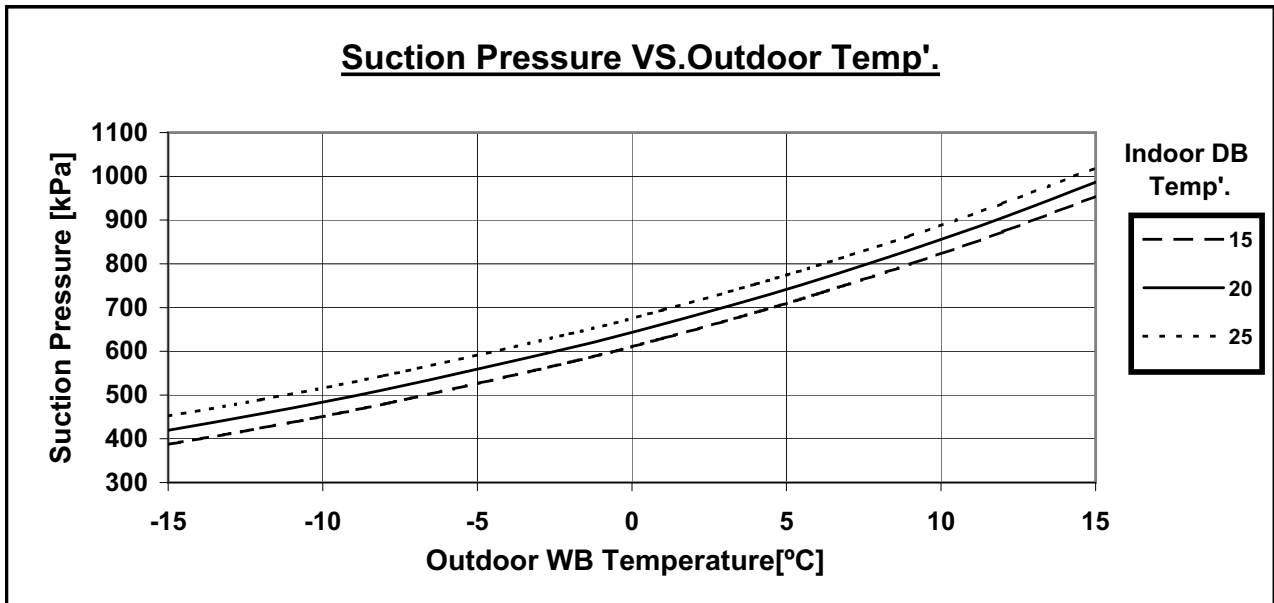

7. ELECTRICAL DATA

7.1 Single Phase Units

MODEL	TRIO 5.2 kW DELTA
Power Supply	1 PH, 220-240 VAC, 50Hz
Connected to	Delta 22, 25 and 35
Maximum Current	9.4 A
Inrush Current*	35 A
Starting Current**	10.5 A
Circuit breaker	20 A
Power supply wiring - No. x cross section, mm ²	3 X 2.5
Interconnecting cable - No. x cross section, mm ²	4 X 1.5

Note:

- * Inrush current is the current when power is up. (charging the DC capacitors at outdoor unit controller).
- ** Starting current is the current when starting the compressor

NOTE

Power wiring cord should comply with local laws and electrical regulations requirements.

8. WIRING DIAGRAMS

8.1 TRIO 5.2 DELTA DCI

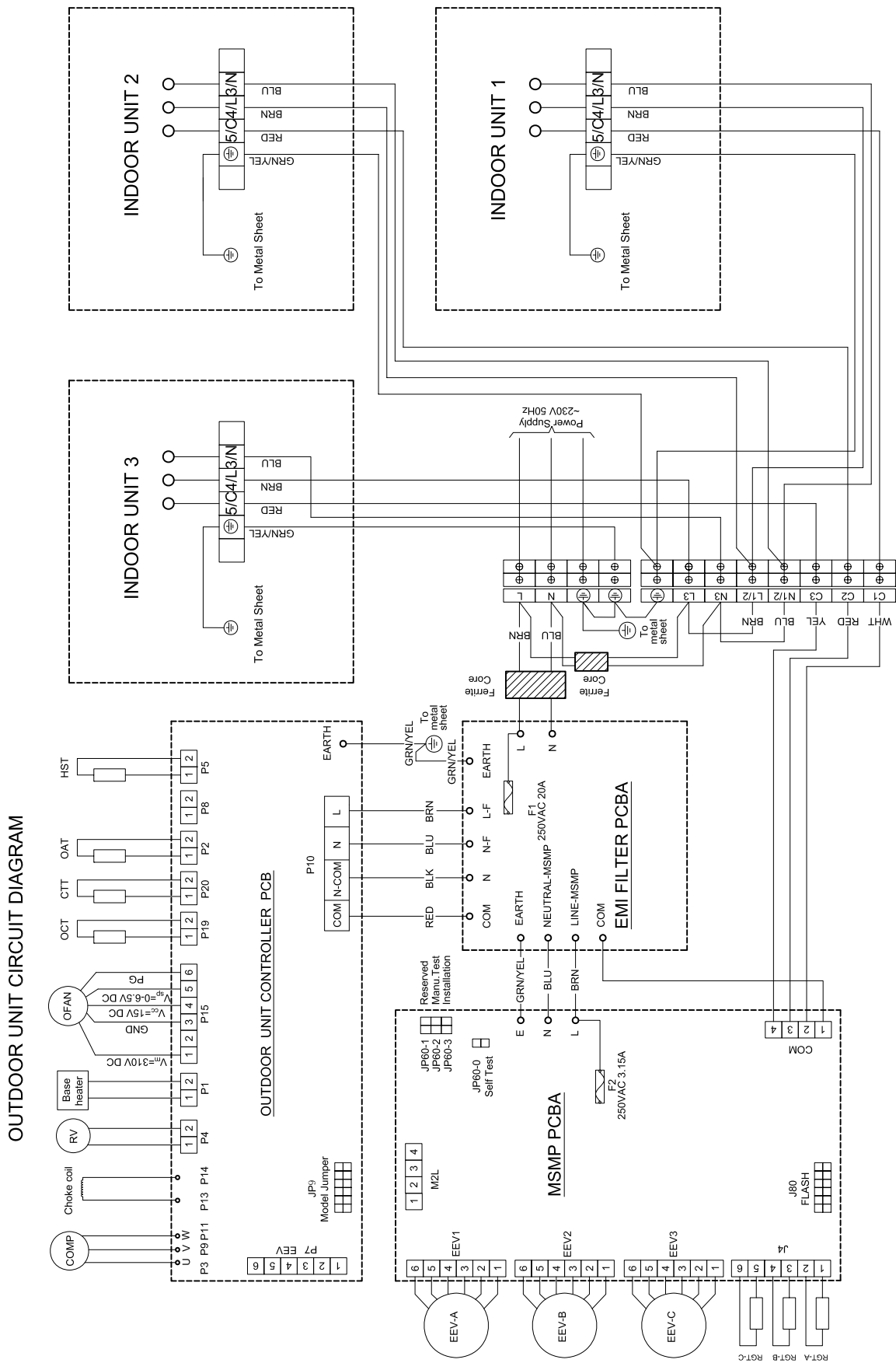

9. REFRIGERATION DIAGRAMS

9.1 Heat Pump Models

9.1.1 TRIO 5.2 DELTA => Cooling & Heating Mode

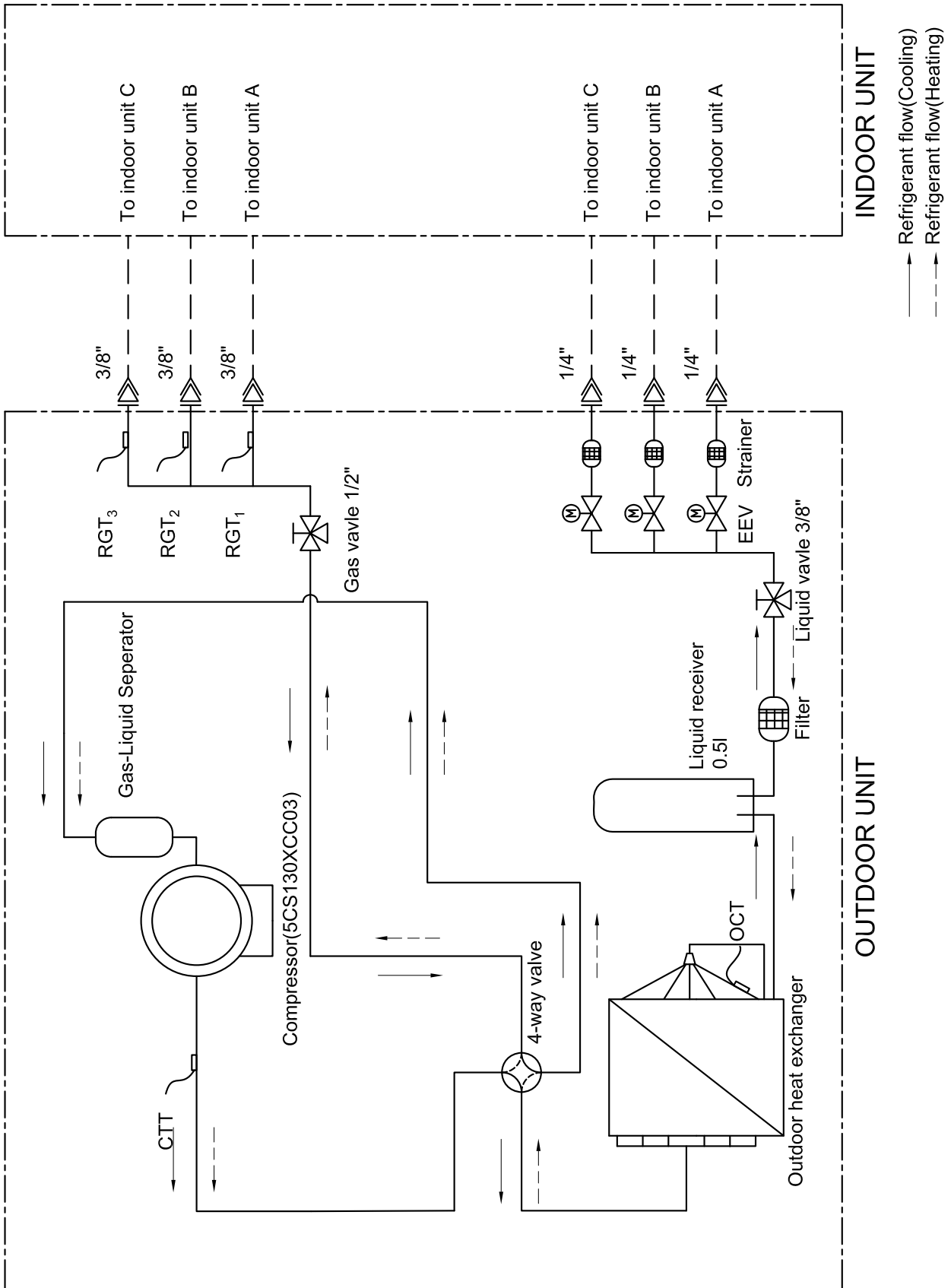

10. TUBING CONNECTIONS

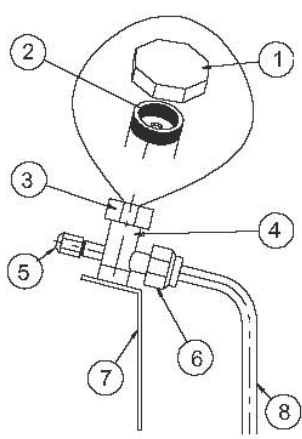
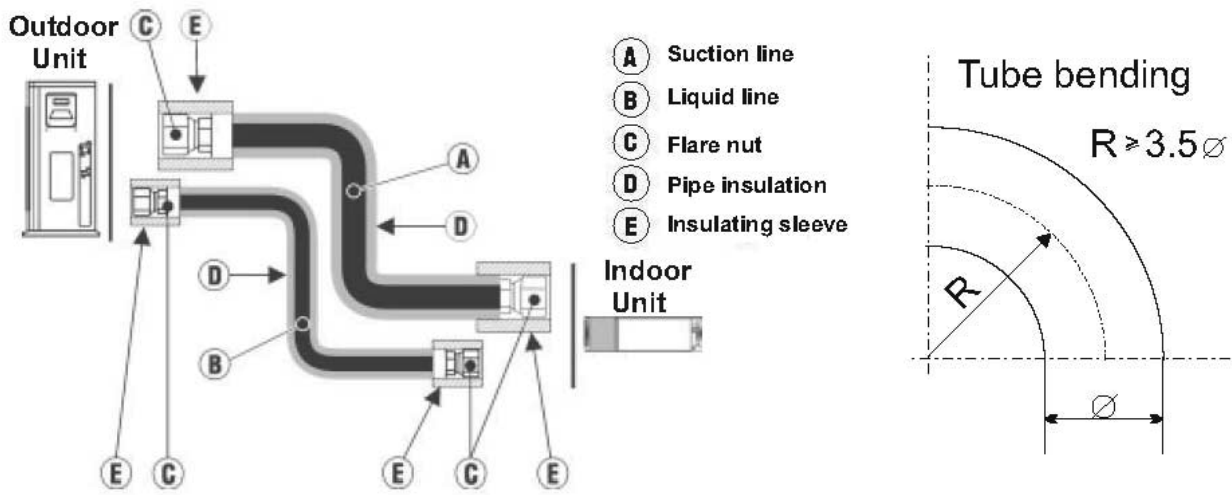

TUBE (Inch)	1/4"	3/8"	1/2"	5/8"	3/4"
TORQUE (Nm)					
Flare Nuts	11-13	40-45	60-65	70-75	80-85
Valve Cap	13-20	13-20	18-25	18-25	40-50
Service Port Cap	11-13	11-13	11-13	11-13	11-13

1. Valve Protection Cap-end
2. Refrigerant Valve Port (use Allen wrench to open/close)
3. Valve Protection Cap
4. Refrigerant Valve
5. Service Port Cap
6. Flare Nut
7. Unit Back Side
8. Copper Tube

When the outdoor unit is installed above the indoor unit an oil trap is required every 5m along the suction line at the lowest point of the riser. In case the indoor unit is installed above the outdoor, no trap is required.

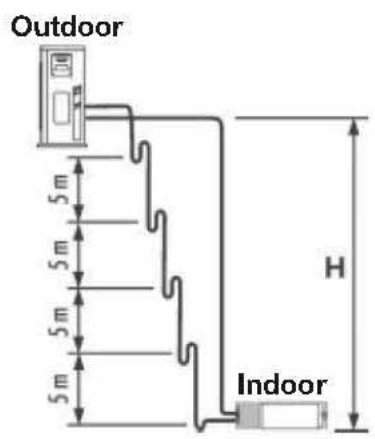

11. CONTROL SYSTEM

11. CONTROL SYSTEM

11.1 General Functions and Operating Rules

The DCI software is fully parametric.

All the model dependent parameters are shown in Blue color and with Italic style [*parameter*]. The parameters values are given in the last section of this control logic chapter of the service manual.

11.2 System Operation Concept

The control function is divided into indoor, MSMP and main outdoor unit controllers. MSMP is a specific PCB in outdoor unit which serves as a bridge between all indoor units and outdoor unit. It communicates with the outdoor unit as one indoor unit and communicates with each indoor unit as one outdoor unit. Each indoor unit will send the request to MSMP for cooling/heating capacity supply. MSMP will deal with all the requests from indoor units and send an integral capacity request to outdoor unit. The outdoor unit will supply the required capacity unless it enters into a protection mode avoiding it from supplying the requested capacity.

The capacity request is transferred via indoor, MSMP and outdoor communication, and is represented by a parameter called 'NLOAD'. NLOAD is an integer number with values between 0 and 127, and it represents the total heat or cool load felt by all the indoor units.

11.3 Compressor Frequency Control

11.3.1 NLOAD setting

The NLOAD setting is done by each indoor unit controller, based on a PI control scheme. MSMP will deal with request from each unit and send a synthetical NLOAD to the outdoor unit. The actual NLOAD to be sent to the outdoor unit controller is based on the calculated LOAD from MSMP and the power shedding function.

NLOAD limits as a function of indoor fan speed:

Indoor Fan Speed	Maximum NLOAD Cooling	Maximum NLOAD Heating
Low	<i>Max NLOADIF1C</i>	127
Medium	<i>Max NLOADIF2C</i>	127
High	<i>Max NLOADIF3C</i>	127
Turbo	<i>Max NLOADIF4C</i>	127
Auto	<i>Max NLOADIF5C</i>	127

Outdoor unit NLOAD calculation by MSMP:

$$ODU\ NLOAD = \min \left\{ \frac{\sum_{i=1}^n CalcIDU\ NLOAD_i \cdot Code_i}{ODUNomCode}, 127 \right\}$$

NLOAD limits as a function of power shedding:

Mode	Power Shedding OFF	Power Shedding ON
Cool	No limit	Nominal Cooling
Heat	No limit	Nominal Heating

11.3.2 Target Frequency Setting

The compressor target frequency is a function of the NLOAD number sent from MSMP and the outdoor air temperature.

Basic Target Frequency Setting:

NLOAD	Target Frequency
127	Maximum frequency
10 < NLOAD < 127	Interpolated value between minimum and maximum frequency
10	Minimum frequency
0	Compressor is stopped

Target frequency limits as a function of outdoor air temperature (OAT):

OAT Range	Cool mode limits	Heat mode limits
OAT < 6	MaxFreqAsOATC	No limit
6 ≤ OAT < 15		MaxFreqAsOAT1H
15 ≤ OAT < 24		MaxFreqAsOAT2H
24 ≤ OAT	No limit	

11.3.3 Frequency Changes Control

Frequency change rate is 1 Hz/sec.

11.3.4

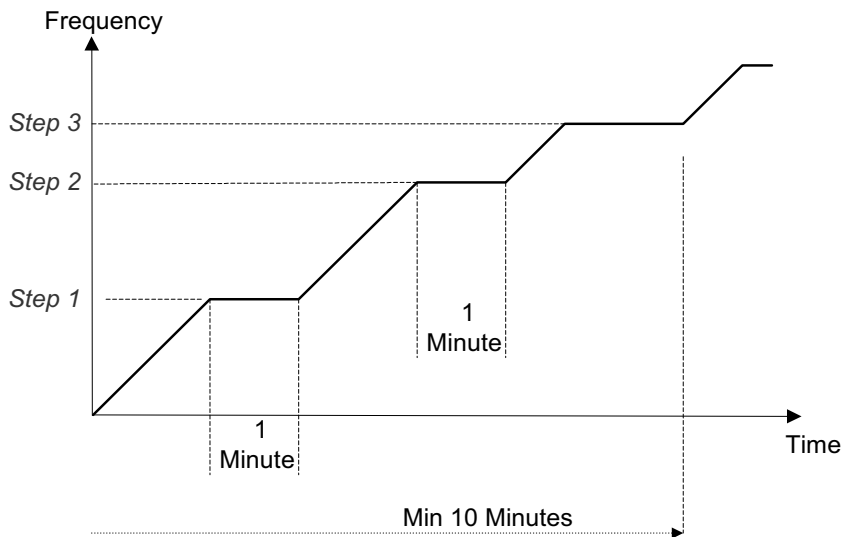

11.3.5 Minimum On and Off Time

3 minutes.

11.4 Indoor Fan Control

10 Indoor fan speeds are determined for each model. 5 speeds for cooling/dry/fan modes and 5 speeds for heating mode.

When user sets the indoor fan speed to a fixed speed (Low/ Medium/ High), unit will operate constantly at set speed.

When Auto Fan is selected, indoor unit controller can operate in all speeds. The actual speed is set according to the cool/heat load.

11.4.1 Turbo Speed

The Turbo speed is activated during the first 30 minutes of unit operation when auto fan speed is selected and under the following conditions:

- Difference between set point and actual room temperature is bigger then 3 degrees.
- Room temperature > 22 for cooling, or < 25 for heating.

11.5 Heating Element Control

Heating element can be started if $LOAD > 0.8 * \text{Maximum NLOAD}$ AND Indoor Coil temperature < 45.

The heating element will be stopped when $LOAD < 0.5 * \text{Maximum NLOAD}$ OR if Indoor Coil temperature > 50.

11.6 Outdoor Fan Control

7 outdoor fan speeds are determined for each model. 3 speeds for cooling and dry modes, and 3 speeds for heating mode, and a very low speed.

Outdoor fan speed is a function of compressor frequency and outdoor air temperature (OAT).

4 routines for fan control are determined. The control routine selection depends on operation mode, compressor speed, and outdoor air temperature (OAT) and heat sink temperature (HST).

Routine	Conditions
A	Heating with $OAT < 15^{\circ}C$ or Cooling with $OAT > 20^{\circ}C$, or $HST > 50^{\circ}C$ or Faulty OAT
B	Cooling with $20^{\circ}C > OAT > 7^{\circ}C$
C	Cooling with $7^{\circ}C > OAT$
D	Heating with $OAT > 15^{\circ}C$

Compressor Frequency (CF)	Outdoor Fan Speed			
	Routine A	Routine B	Routine C	Routine D
$CF = 0$	OFF	OFF	OFF	OFF
$10 \leq CF < OF_{LowFreq}$	Low	Low	Very Low	Low
$10 \leq CF < OF_{MedFreq}$	Medium	Low	Very Low	Low
$OF_{MedFreq} \leq CF$	High	Low	Low	Medium

When compressor is switched to OFF and the heat sink temperature is above 55 degrees, the outdoor fan will remain ON in low speed for up to 3 minutes.

11.7 EEV (electronic Expansion valve) Control

- EEVi opening of the 'i' indoor unit is defined as $EEVi = EEV_{OLi} + EEV_{Cvi}$
- EEV_{OLi} is the initial EEV opening as a function of the compressor frequency, operation mode, unit model and capacity.
 - EEV_{Cvi} is a correction value for the EEV opening that is based on the compressor temperature.
 - During the first 5 minutes of compressor operation $EEV_{Cvi} = 0$.
 - Once the first 5 minutes are over, the correction value is calculated as follow: $EEV_{Cvi}(n) = EEV_{Cvi}(n-1) + EEV_{SHi} + EEV_{CTTi}$
 $EEV_{SHi} = EEV_{minSHi} + EEV_{deltaSHi}$
 - EEV_{minSHi} is correction for the EEV opening of the 'i' indoor unit as of the whole system superheat.
 - $EEV_{deltaSHi}$ is correction for the EEV opening of the 'i' indoor unit as of balance between each unit.
 - EEV_{CTTi} is the correction for the EEV opening of the 'i' indoor unit based on the compressor temperature. A target compressor temperature is set depending on frequency and outdoor air temperature, and the actual compressor temperature is compared to the target temperature to set the required correction to the EEV opening.

11.8 Reversing Valve (RV) Control

Reversing valve is on in heat mode.

Switching of RV state is done only after compressor is off for over 3 minutes.

11.9 Electro Static Filter (ESF) Control

ESF is on when ESF switch is on, Safety switch is pressed, unit is on, AND indoor fan is on.

11.10 Base Heater Control

When OAT is connected, Base Heater will be on when unit is in heating and $OAT < 2^{\circ}C$.

When OAT is disconnected, Base Heater will be on when unit is in heating.

11.11 Indoor Units Operation when Indoor Unit Mode is Different than Outdoor Unit Mode

- Open louvers according to user selection.
- Indoor fan is forced to OFF.
- Led blinks every 2 second

11.12 Fan Mode

In high/ medium/ low indoor fan user setting, unit will operate fan in selected speed.

In Auto Fan user setting, fan speed will be adjusted automatically according to the difference between actual room temperature and user set point temperature.

11.13 Cool Mode

NLOADi is calculated according to the difference between actual room temperature and user set point temperature by PI control.

In high/ medium/ low indoor fan user setting, unit will operate fan in selected speed.

In Auto Fan user setting, fan speed will be adjusted automatically according to the calculated NLOADi.

11.14 Heat Mode

NLOADi is calculated according to the difference between actual room temperature and user set point temperature by PI control.
 In high/ medium/ low indoor fan user setting, unit will operate fan in selected speed.
 In Auto Fan user setting, fan speed will be adjusted automatically according to the calculated NLOADi.

11.14.1 Temperature Compensation

In wall mounted, ducted, and cassette models, 3 degrees are reduced from room temperature reading (except when in I-Feel mode), to compensate for temperature difference between high and low areas in the heated room, and for coil heat radiation on room sensor.

The temperature compensation can be activate or deactivate by shortening of jumper J2 on the indoor unit controller.

Model	J2 Shorted	J2 Opened
Wall mounted	Compensation Disabled	Compensation Enabled
Cassette	Compensation Enabled	Compensation Disabled
Ducted	Compensation Enabled	Compensation Disabled
Floor/Ceiling	Compensation Disabled	Compensation Enabled

11.14.2 Indoor Fan Control in Heat Mode

Indoor fan speed depends on the indoor coil temperature:

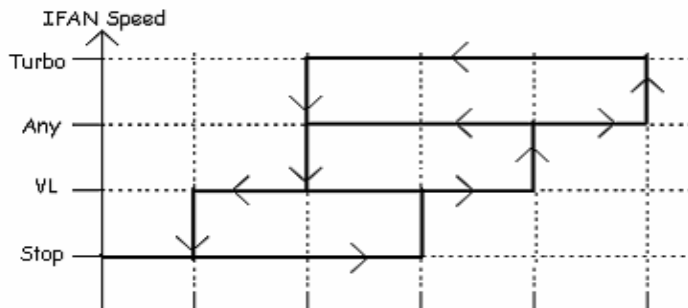

11.15 Auto Cool/Heat Mode

When in auto cool heat mode unit will automatically select between cool and heat mode according to the difference between actual room temperature and user set point temperature (ΔT).

Unit will switch from cool to heat when compressor is off for 3 minutes, and $\Delta T < -3$.

Unit will switch from heat to cool when compressor is off for 5 minutes, and $\Delta T < -3$.

11.16 Dry Mode

As long as room temperature is higher then the set point, indoor fan will work in low speed and compressor will work between 0 and *MaxNLOADIF1C* Hz.

When the room temperature is lower than the set point, compressor will be switched OFF and indoor fan will cycle 3 minutes OFF, 1 minute ON.

11.17 Protections

There are 5 protection codes.

Normal (Norm) – unit operate normally.

Stop Rise (SR) – compressor frequency can not be raised but does not have to be decreased.

HzDown1 (D1) – Compressor frequency is reduced by 2 to 5 Hz per minute.

HzDown2 (D2) – Compressor frequency is reduced by 5 to 10 Hz per minute.

Stop Compressor (SC) – Compressor is stopped.

The MSMP receives the protection status from each one of the indoor unit. It calculates the overall outdoor unit protection status based on each ‘i’ indoor unit protection status weight according to the following average:

$$ODU \text{ protection weight} = \text{round up} \left(\frac{\sum_{i=1}^n IDU_i \text{ protection status weight}}{n} \right)$$

11.17.1 Indoor Coil Defrost Protection

ICT	ICT Trend				
	Fast Increasing	Increasing	No change	Decreasing	Fast Decreasing
ICT < -2	SC	SC	SC	SC	SC
-2 ≤ ICT < 0	D1	D1	D2	D2	D2
0 ≤ ICT < 2	SR	SR	D1	D2	D2
2 ≤ ICT < 4	SR	SR	SR	D1	D2
4 ≤ ICT < 6	Norm	Norm	SR	SR	D1
6 ≤ ICT < 8	Norm	Norm	Norm	SR	SR
8 ≤ ICT	Normal				

11.17.2 Indoor Coil over Heating Protection

ICT	ICT Trend				
	Fast Decreasing	Decreasing	No Change	Increasing	Fast Increasing
ICT > 55	SC	SC	SC	SC	SC
53 < ICT ≤ 55	D1	D1	D2	D2	D2
49 < ICT ≤ 53	SR	SR	D1	D2	D2
47 < ICT ≤ 49	SR	SR	SR	D1	D2
45 < ICT ≤ 47	Norm	Norm	SR	SR	D1
43 < ICT ≤ 45	Norm	Norm	Norm	SR	SR
ICT ≤ 43	Normal				

11.17.3 Compressor over Heating Protection

Compressor temperature can be in one of 5 control zones (4 in protection, and 1 normal), according to the following chart.

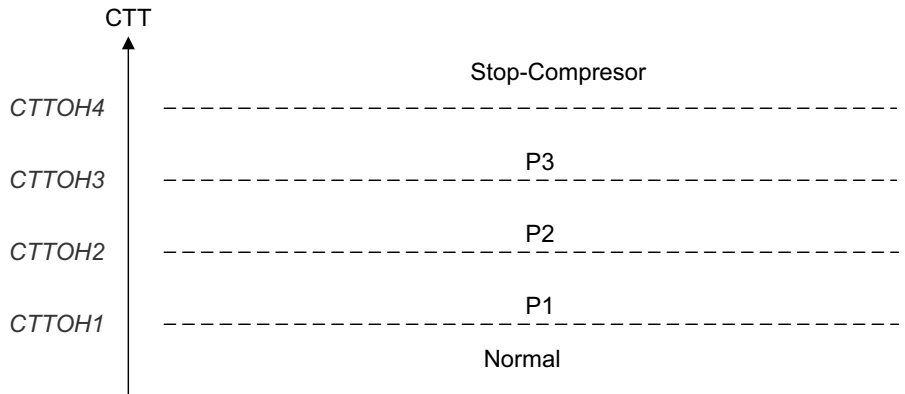

Control Status	Compressor Temperature Increases	Else
P1	Norm	SR
P2	D1	SR
P3	D2	D1
Stop Compressor	SC	

11.17.4 Compressor over Current Protection

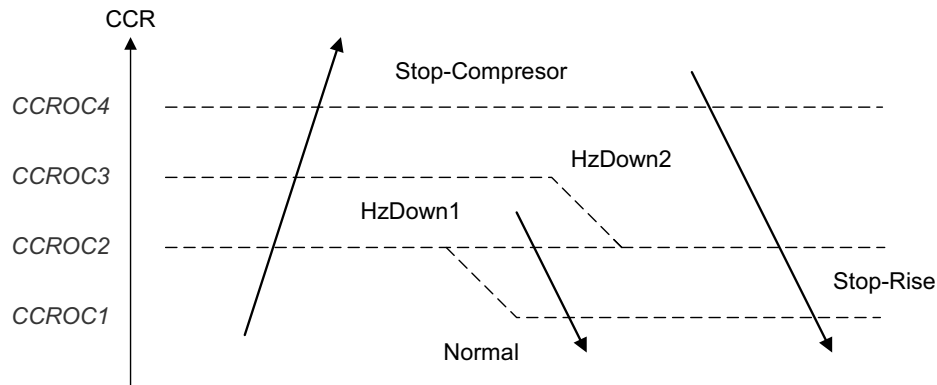

11.17.5 Outdoor Coil Deicing Protection

11.17.5.1 Deicing Starting Conditions

Deicing operation will start when either one of the following conditions exist:

- Case 1: $OCT < OAT - 8$ AND $TLD > DI$
- Case 2: $OCT < OAT - 12$ AND $TLD > 30$ minutes.
- Case 3: OCT is Invalid AND $TLD > DI$
- Case 4: Unit is just switched to STBY AND $OCT < OAT - 8$
- Case 5: $NLOAD = 0$ AND $OCT < OAT - 8$

OCT – Outdoor Coil Temperature

TLD – Time from Last Deicing

DI – Deicing Interval (Time Interval Between Two Deicing)

Deicing interval time when compressor is first started in heat mode, is 10 minutes if $OCT < -2$, and is 40 minutes in other cases.

Deicing interval time is changed (increased/ decreased in 10 minutes steps) as a function of deicing time. If deicing time is shorter than former deicing time, the deicing interval time will be increased. If deicing time is longer than former deicing time, the deicing interval time will be decreased.

11.17.5.2 Deicing Protection Procedure

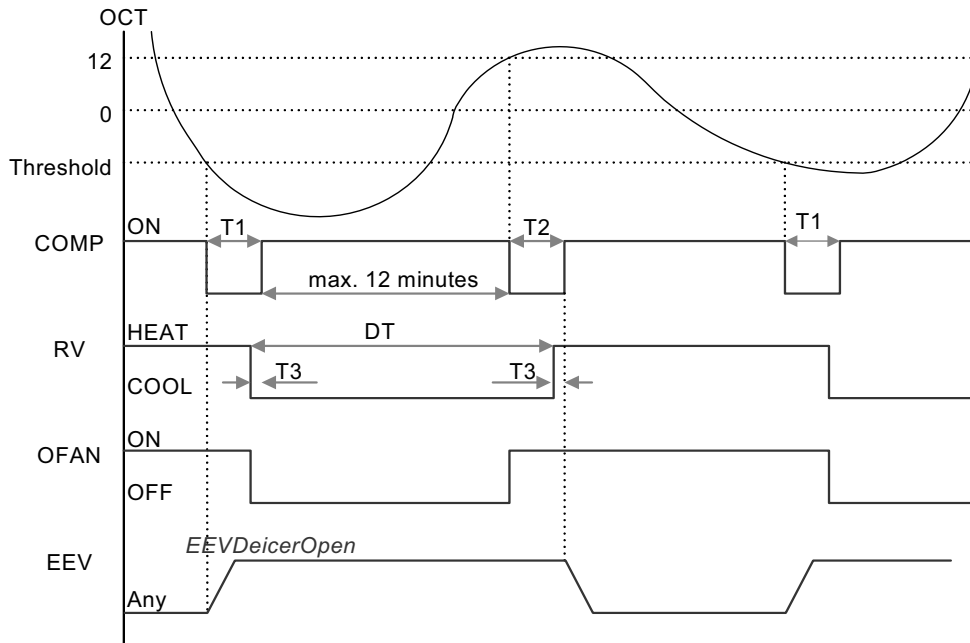

T1 = T2 = 36 seconds, T3 = 6 seconds

11.18 Indoor Unit Dry Contact (excluding Delta range)

Indoor unit Dry contact has two alternative functions that are selected by J8.

	Function	Contact = Open	Contact = Short
J8 = Open	Presence Detector Connection	No Limit	Forced to STBY
J8 = Short	Power Shedding Function	No Limit	Limit NLOAD

11.19 Operating the Unit from the Mode Button

Forced operation allows starting up, shutting down and operating in Cooling or Heating mode, in pre-set temperature according to the following table:

Forced operation Mode	Pre-set Temperature
Cooling	20°C
Heating	28°C

11.20 On Unit Controls and Indicators

11.20.1 Indoor Unit Controls and Indicators for Led Display

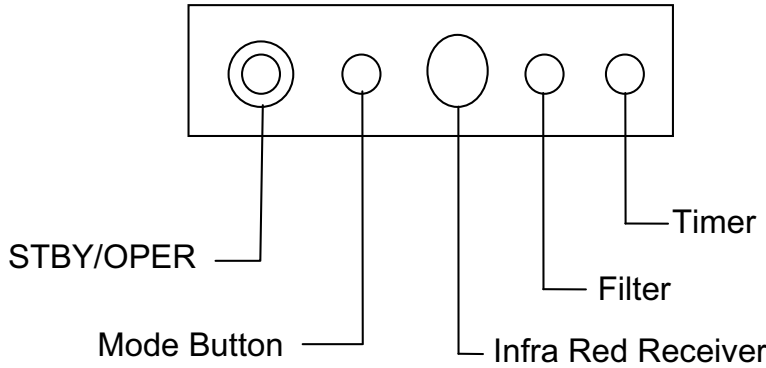

<p>STAND BY INDICATOR</p>	<ol style="list-style-type: none"> 1. Lights up when the Air Conditioner is connected to power and the mode is STBY. 2. Blinks for 3 seconds, when the system is switched to Heat Mode by using the Mode/Reset Switch on the unit (the operation indicator will be off during this blinking time).
<p>OPERATION INDICATOR</p>	<ol style="list-style-type: none"> 1. Lights up during operation mode (except for item in STBY indicator). 2. Blinks for 300 msec., to announce that a R/C infrared signal has been received and stored. 3. Blinks continuously during protections (according to the relevant spec section). 4. Blinks for 3 seconds when the system is switched to Cool Mode by using the Mode/Reset Switch on the unit.
<p>TIMER INDICATOR</p>	<p>Lights up during Timer and Sleep operation.</p>
<p>FILTER INDICATOR</p>	<p>Lights up when Air Filter needs to be cleaned.</p>
<p>MODE/RESET BUTTON</p>	<p>As long as the filter Led is off, the Mode/Reset button functions as Mode switch. Once filter Led is on, the Mode/Reset button functions as Reset switch.</p> <p><u>Mode Function:</u> Every short pressing , the next operation mode is selected, in this order: SB → Cool Mode → Heat Mode → SB → ... In long pressing system enters diagnostic mode (refer to diagnostic mode Sect.)</p> <p><u>Reset Function:</u> For short pressing: When Filter LED is on, it turns off the filter indicator.</p>

Notes

1. Pressing time is defined as the time between press and release.
2. If pressing time is one second or less – press is considered as short pressing.
3. If pressing time is three seconds or longer – pressing is considered as long pressing.
In between, pressing is undetermined and system will not respond to pressing.
4. For the LED functionality during diagnostics, refer to the diagnostics Sect.

11.20.2 Outdoor Unit Controller Indicators

Unit has three LED's.

SB LED is ON when power is ON (230 VAC, even when no communication).

STATUS LED is ON when COMP is ON, and Blinks according to diagnostics mode definitions when either fault or protection occurs.

FAULT LED Blinks according to diagnostics mode definitions when either fault or protection occurs.

11.21 Test Mode**11.21.1 Entering Test Mode**

System can enter Test mode in two ways:

- Automatically when the following conditions of outdoor unit and each indoor unit both exists for 30 minutes continuously:
 - Mode = Cool, Set point = 16, Room temperature = 27 ± 1 , Outdoor temperature = 35 ± 1
- Or
- Mode = Heat, Set point = 30, Room temperature = 20 ± 1 , Outdoor temperature = 7 ± 1
 - Manually when entering diagnostics of each indoor unit with the following settings:
 - Mode = Cool, Set point = 16
 - Mode = Heat, Set point = 30

11.22 Unit Operation in Test Mode

In test mode, the unit will operate in fixed settings according to the indoor fan speed setting:

Indoor Fan Speed Setting	Unit Setting
Low	Minimum Capacity Setting
High	Nominal Capacity Setting
Auto	Maximum Capacity Setting

During test mode, protections are disabled, except for stop compressor status.

SW Parameters

Indoor Units SW Parameters

General Parameters for All Models:

Parameters defining the indoor fan speed as a function of Indoor Coil temperature in heat mode (ICT):

ICTST Speed	ICT to stop indoor fan	23
ICTVLSpeed	ICT to go down to very low speed	26
ICTLSpeed	ICT to start in very low speed	28
ICTHSpeed	ICT to start in increase speed from very low	30
ICTTSpeed	ICT to enable Turbo fan speed	40

Parameters for defrost protection:

ICTDef1	ICT to go back to normal	8
ICTDef2	ICT to 'stop rise' when ICT decrease	6
ICTDef3	ICT to 'stop rise' when ICT is stable	4
ICTDef4	ICT to 'Hz Down' when ICT decrease	2
ICTDef5	ICT to 'Hz Down' when ICT is stable	0
ICTDef6	ICT to stop compressor	-2

Parameters for indoor coil over heating protection:

ICTOH1	ICT to go back to normal	45
ICTOH2	ICT to 'stop rise' when ICT increase	48
ICTOH3	ICT to 'stop rise' when ICT is stable	52
ICTOH4	ICT to 'Hz Down' when ICT increase	55
ICTOH5	ICT to 'Hz Down' when ICT is stable	60
ICTOH6	ICT to stop compressor	62

Model Depended Parameters:

Parameter name	Wall Mounted Models		
	Delta 22	Delta 25	Delta 35
NLOAD limits as a function of selected indoor fan speed			
MaxNLOADIF1C	40	40	40
MaxNLOADIF2C	55	51	55
MaxNLOADIF3C	120	90	90
MaxNLOADIF4C	127	127	127
MaxNLOADIF5C	127	127	127
Indoor Fan speeds			
IFVLOWC	700	700	700
IFLOWC	800	850	850
IFMEDC	950	1050	1000
IFHIGHC	1050	1200	1200
IFTURBOC	1150	1250	1250
IFVLOWH	700	700	700
IFLOWH	850	950	950
IFMEDH	1000	1050	1100
IFHIGHH	1100	1250	1250
IFTURBOH	1200	1350	1300
Nominal Compressor Frequency			
NomLoadC	40	51	61
NomLoadH	55	58	62

Outdoor Units SW Parameters

Parameter Name	TRIO 5.2 DELTA
Compressor Parameters	
MinFreqC	20
MaxFreqC	100
MinFreqH	25
MaxFreqH	100
Step1Freq	40
Step2Freq	80
Step3Freq	90
Frequency limits as a function of outdoor air temperature	
MaxFreqAsOATC	80
MaxFreqAsOAT1H	90
MaxFreqAsOAT2H	60
Compressor Over Heating Protection	
CTTOH1	90
CTTOH2	98
CTTOH3	102
CTTOH4	105
Compressor Over Current Protection [A]	
CCR01	11.4
CCR02	11.8
CCR03	12.2
CCR04	12.6
Outdoor Fan Speed (RPM)	
VL	200
OFLOWC	400
OFMEDC	600
OFMAXC	770
OFLOWH	400
OFMEDH	600
OFMAXH	720

12. TROUBLESHOOTING

1 ELECTRICAL & CONTROL TROUBLESHOOTING

WARNING!!!

When Power Up – the whole outdoor unit controller, including the wiring, is under HIGH VOLTAGE!!!
 Never open the Outdoor unit before turning off the Power!!!
 When turned off, the system is still charged (400V)!!!
 It takes about 3 Min. to discharge the system.
 Touching the controller before discharging may cause an electrical shock!!!

For safe handling of the controller please refer to section 1.6 below.

1.1 Dual Split System Failures and Corrective Actions

No	SYMPTOM	PROBABLE CAUSE	CORRECTIVE ACTION
1	Power supply indicator at indoor unit (Red LED) does not light up.	No power supply	Check power supply from the outdoor. If power supply is OK, check display and display wiring. If OK, replace controller.
2	Indoor fan does not start (louvers are opened and Green LED does light up)	Unit in heat mode and coil is still not warm.	Change to cool mode and check.
		The outdoor unit is in the opposite mode.	Change operation mode and check if fan starts.
		Problem with PCB or capacitor	Change to high speed and Check power supply to motor is higher than 130VAC (for Triac controlled motor) or higher than 220VAC for fixed speed motors, if OK replace capacitor, if not OK replace controller
3	Compressor does not start	Jumper settings of outdoor unit is not correct	Use diagnostics information on MSMP board.
4	One indoor is operating, in cool mode, with no capacity, and the other unit has water leaks/freezing problems	The communication wires of the two indoor units are switched	Check and correct the communication wires connection
5	One indoor is operating in heat mode with a limited capacity, and the coil on the other unit is very hot.		
6	Compressor operate but unit generate no capacity		
7	One unit only is operating	EEV is stuck in close position Communication problems	Check EEV Use diagnostics information on MSMP board.
8	All others	Specific problems of indoor or outdoor units	Use diagnostics information on MSMP board, and perform action items as recommended in single split systems

1.2 Checking the Refrigeration System

Checking system pressures and other thermodynamic measures should be done when system is in Test Mode (in Test mode, system operates in fixed settings). The performance curves given in this manual are given for unit performance in test mode when high indoor fan speed is selected.

Entering test mode:

Set the two indoor units to Cool/16 degrees/High indoor fan speed, or Heat/30 degrees/High indoor fan speed, and enter diagnostics. Note: the two indoor units should be set to the same mode and fan speed.

1.3 Judgment by MSMP Diagnostics

The MSMP controller has 9 LED's (4 green Unit LEDs and 5 red Status/Fault LEDs). For the 4 green Unit LEDs, O-Outdoor unit, A-Indoor unit 1, B-Indoor unit 2, C-Indoor unit 3. For the 5 red Status/Fault LEDs, it should be read from O-A-B-C-D to get fault numbers. The 4 green Unit LEDs will turn on one at a time and the corresponding Indoor/Outdoor unit status/fault code will be displayed on the red Status/Fault LEDs. If the unit is normal (no fault), the green unit LED and the corresponding status will be displayed for 5 seconds and move to the next green unit LED. On the other hand, if the unit is in fault, the green unit LED and the corresponding fault will be displayed for 10 seconds, and hence more time to read the fault code.

STBY LED is ON when power is ON.

1.3.1 MSMP Fault Code for Outdoor unit:

No	Problem	5	4	3	2	1	Possible reason	Corrective Action
1	OCT is disconnected	0	0	0	0	1	1.OCT is not connected to controller terminal; 2.OCT is cut out; 3.Controller is damaged	In case1, reinstall OCT and make sure it's connected well; If fault still exists, move to check case2, use a multimeter to check OCT's resistor, if it's $+\infty$, OCT is damaged and change a new one; if it's around 10K(at 25 \square), then move to case 3; In case 3, change a new controller.
2	OCT is shorted	0	0	0	1	0	1.OCT is shorted; 2.Controller is shorted	In case 1, use a multimeter to check OCT's resistor, if it's 0, OCT is damaged and change a new one; if it's around 10K(at 25 \square), then move to case 2; In case 2, change a new controller.
3	CTT is disconnected	0	0	0	1	1	Similar as item 1	Similar as item 1
4	CTT is shorted	0	0	1	0	0	Similar as item 2	Similar as item 2
5	HST is disconnected (when enabled)	0	0	1	0	1	Similar as item 1	Similar as item 1
6	HST is shorted (when enabled)	0	0	1	1	0	Similar as item 2	Similar as item 2
7	OAT is disconnected (when enabled)	0	0	1	1	1	Similar as item 1	Similar as item 1
8	OAT is shorted (when enabled)	0	1	0	0	0	Similar as item 2	Similar as item 2
9	TSUC is disconnected (when enabled)	0	1	0	0	1	Similar as item 1	Similar as item 1
10	TSUC is shorted (when enabled)	0	1	0	1	0	Similar as item 2	Similar as item 2
11	IPM	0	1	0	1	1	Possibly damaged.	Turn OFF the system. Check wiring. Wait for 3 minutes and turn ON again. If the fault still exists, return the controller to factory and report the fault code.
12	Bad ODU EEPROM	0	1	1	0	0	Similar as item 11.	Similar as item 11.
13	DC under voltage	0	1	1	0	1	Similar as item 11.	Similar as item 11.
14	DC over voltage	0	1	1	1	0	Similar as item 11.	Similar as item 11.
15	AC under voltage	0	1	1	1	1	Similar as item 11.	Similar as item 11.
16	IDU/ODU Communication mismatch	1	0	0	0	0	Possibly miss-wiring between IDU and ODU.	Check connection between IDU and ODU.
17	No Communication	1	0	0	0	1	Possibly mis-wiring between IDU and ODU.	Check connection between IDU and ODU.
18	Illegal ODU Model	1	0	0	1	0	ODU Model jumper setting is wrong;	Check the jumper setting according to the model table on the controller label

19	Bad MSMP EEPROM	1	0	0	1	1	Similar as item 11.	Similar as item 11.
20	Heat sink Over Heating	1	0	1	0	0	Normal AC protection	Turn OFF the system and wait for 30 minutes. Turn ON the system again. If the fault still exists, return the controller to factory and report the fault code.
21	Deicing	1	0	1	0	1	Normal AC protection, no need action.	
22	Compressor Over Heating	1	0	1	1	0	Normal AC protection, no need action.	
23	Compressor Over Current	1	0	1	1	1	Normal AC protection, no need action.	
24	No OFAN Feedback	1	1	0	0	0		Check for OFAN connection between controller and OFAN.
25	OFAN locked	1	1	0	0	1		Check for OFAN connection between controller and OFAN.
26	Compressor start up fail	1	1	0	1	0		Check for compressor wire connection.
27	Bad Communication	1	1	0	1	1	Check for wiring between IDU and ODU.	
...	Reserved							
29	No Fault (Heat Mode)	1	1	1	0	1		
30	No Fault (Cool, Dry, Fan Mode)	1	1	1	1	0		
31	No Fault (Stand By)	1	1	1	1	1		

1.3.2 MSMP Fault Code for Indoor Unit:

No	Problem	5	4	3	2	1	Possible Reason	Corrective Action
1	RT-1 is disconnected	0	0	0	0	1	1. RT-1 is not connected to controller terminal; 2. RT-1 is cut out; 3. Controller is damaged	In case 1, reinstall RT-1 and make sure it's connected well; If fault still exists, move to check case 2, use a multimeter to check RT-1's resistor, if it's $+\infty$, RT-1 is damaged and change a new one; if it's around 10K(at 25 $^{\circ}$ C), then move to case 3; In case 3, change a new controller.
2	RT-1 is shorted	0	0	0	1	0	1. RT-1 is shorted; 2. Controller is shorted	In case 1, use a multimeter to check RT-1's resistor, if it's 0, RT-1 is damaged and change a new one; if it's around 10K(at 25 $^{\circ}$ C), then move to case 2; In case 2, change a new controller.
3	RT-2 is disconnected	0	0	0	1	1	Similar as item 1	Similar as item 1
4	RT-2 is shorted	0	0	1	0	0	Similar as item 2	Similar as item 2
5	RGT is disconnected	0	0	1	0	1	Similar as item 1	Similar as item 1
6	Reserved	0	0	1	1	0		
7	Communication mismatch	0	0	1	1	1	Possibly mis-wiring.	
8	No Communication	0	1	0	0	0	Possibly mis-wiring.	
9	No Encoder	0	1	0	0	1	Possibly mis-wiring, controller damaged or fan motor damaged.	
10	Reserved	0	1	0	1	0		
11	Outdoor unit fault	0	1	0	1	1		Refer to 1.3.1
12	Reserved	0	1	1	0	0		
13	Reserved	0	1	1	0	1		
14	Reserved	0	1	1	1	0		
15	Reserved	0	1	1	1	1		
17	Defrost protection	1	0	0	0	1	Normal AC protection, no need action	
18	Deicing Protection	1	0	0	1	0	Normal AC protection, no need action	
19	Outdoor Unit Protection	1	0	0	1	1		Refer to 1.3.1
20	Indoor Coil HP Protection	1	0	1	0	0	Normal AC protection, no need action	
21	Overflow Protection	1	0	1	0	1	Normal AC protection, no need action	
22	Reserved	1	0	1	1	0		
23	Reserved	1	0	1	1	1		
24	EEPROM Not Updated	1	1	0	0	0	Possibly damaged.	
25	Bad EEPROM	1	1	0	0	1	Possibly damaged.	
26	Bad Communication	1	1	~	1	~	Check for wiring between IDU and ODU.	
27	Using EEPROM data	1	1	~	1	1	A/C is operating with customized A/C parameters from EEPROM	Use MEGATOOL to reset to default parameters
29	No Fault (Heat Mode)	1	1	1	0	1		
30	No Fault (Cool, Dry, Fan Mode)	1	1	1	1	0		
31	No Fault (Stand By)	1	1	1	1	1		

1.4 judgment by Mega Tool

Mega Tool is a special tool to monitor the system states.

Using Mega Tool requires:

- A computer with RS232C port.
- A connection wire for MegaTool.
- Special MegaTool software.

Use MegaTool according to following procedure:

- Setup MegaTool software: copy the software to the computer.
- Connect RS232C port in computer with MegaTool port in Indoor/Outdoor unit controller by the connection wire.
- Run the software and choose the COM port, you can monitor the A/C system state in monitor tab.

1.5 Simple Procedures for Checking the Main Parts

1.5.1 Checking Mains Voltage.

Confirm that the Mains voltage is between 198 and 264 VAC. If Mains voltage is out of this range, abnormal operation of the system is expected. If in range check the Power (Circuit) Breaker and look for broken or loosed cable lugs or wiring mistake(s).

1.5.2 Checking Power Input.

If Indoor unit power LED is unlighted, power down the system and check the fuse of the Indoor unit. If the fuse is OK replace the Indoor unit controller. If the fuse has blown, replace the fuse and power up again. Checking Power Input procedure for the Outdoor unit is the same as with the Indoor unit.

1.5.3 Checking the PCB.

Appearance inspect: Check discoloration, nick and connection of copper foil, short-circuit and open-circuit, component soldering, bulgy and distortion of electrolytic capacitor.

Power circuit check: check voltage of every power level (5V, 12V, 15V) printed on back of PCB.

1.5.4 Checking the Outdoor Fan Motor.

Enter Test Mode (where the OFAN speed is high)

Check the voltage between lead wires according to the normal value as following:

- Between red wire and black wire: 380VDC +/- 20V
- Between orange wire and black wire: 15VDC +/- 1V
- Between yellow wire and black wire: 2-6VDC

1.5.5 Checking the Compressor.

The compressor is brushless permanance magnetic DC motor. Three coil resistances are same. Check the resistance between three poles. The normal value should be 0.642 ohm (U-V), 0.636 ohm (V-W) and 0.652 ohm (U-W). (Environmental temperature 25°C)

1.5.6 Checking the Reverse Valve (RV).

Running in heating mode, check the voltage between two pins of reverse valve connector, normal voltage is 220VAC.

1.5.7 Checking the Electrical Expansion Valve (EEV).

The EEV has two parts, drive part and valve. The drive part is a step motor; it is ringed on the valve. Check the drive voltage (12VDC). When Outdoor unit is power on, EEV shall run and have click and vibration.

1.6 Precaution, Advise and Notice Items

1.6.1 High voltage in Outdoor unit controller.

Whole controller, including the wires, connected to the Outdoor unit controller may have the potential hazard voltage when power is on. Touching the Outdoor unit controller may cause an electrical shock.

Advise: Don't touch the naked lead wire and don't insert finger, conductor or anything else into the controller when power is on.

1.6.2 Charged Capacitors

Three large-capacity electrolytic capacitors are used in the Outdoor unit controller. Therefore, charging voltage (380VDC) remains after power down. Discharging takes about three minutes after turned off.

Touching the Outdoor unit controller before discharging may cause an electrical shock. When open the Outdoor unit controller cover, don't touch the soldering pin by hand or by any conductive material.

Advise:

1. Open the Outdoor unit controller cover only after five minutes from power down.
2. Measure the electrolytic capacitors voltage before farther checking controller for safety.

1.6.3 Additional advises

- When disassemble the controller or the front panel, turn off the power supply.
- When connecting or disconnecting the connectors on the PCB, hold the whole housing, don't pull the wire.
- There are sharp fringes and sting on shell. Use gloves when disassemble the A/C units.

13. EXPLODED VIEWS AND SPARE PARTS LISTS

13.1 Outdoor Unit: TRIO DELTA 5.2 kw DCI

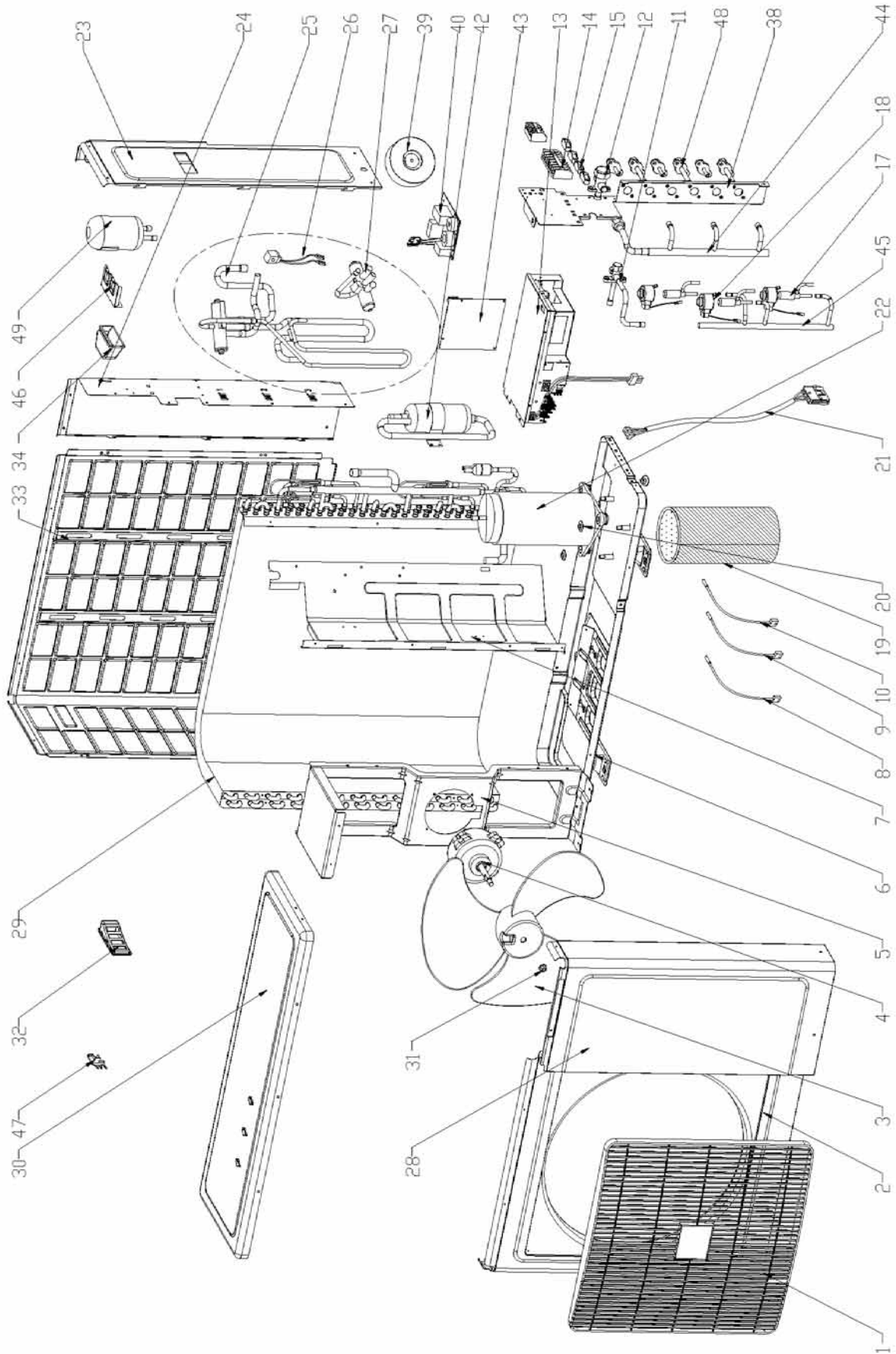

13.2 Outdoor Unit: TRIO DELTA 5.2kw DCI R410A

No.	Item	Description	Qty.
1	4517144	Outlet grid	1
2	452795700	PAINTED LEFT CABINET ASSY	1
3	4526510	OUTDOOR FAN	1
4	453026500R	DC Motor SIC-71FW-F170-2	1
5	453036400	Motor Support	1
6	464600019	Base Plate Painting Assy.	1
7	464160004	Partition Plate	1
8	453238900	Outdoor Air Thermistor(OAT)	1
9	4526775	Compressor Top Thermistor(CTT)	1
10	4526776	Outdoor Coil Thermistor(OCT)	1
11	452783100	High Press Valve R410A	1
12	461010018	Low Press Valve R410A	1
13	453030500	Outdoor DCI Controller/2.8kW	1
14	467420009	4 Poles Terminal Block	1
14	467420010	8 Poles Terminal Block	1
15	204107	Cable clip Nylon	4
17	4526827	Electronical expansion valve CAM-BD15 FKS-1	3
18	452682802	EEV COIL(White Connector 530mm)	1
18	452682800	EEV COIL(Red Connector 530mm)	1
18	452682801	EEV COIL(Yellow Connector 700mm)	1
19	4526477	compressor isulation	1
20	4510677	Nut M8 for compressor	3
21	4526221	cable of compressor	1
22	4526486	Scroll DC compressor 5CS130XCC03	1
23	464630008	Side Plate Painting Assy	1
24	464080001	Painted Right Back Cabinet Assy.	1
25	461600015	4-Way Valve Assy.	1
26	4522509	4-way valve coil	1
27	4518952	Four-Way Valve R410A	1
28	464660009	Painted Right Cabinet Assy.	1
29	452890900	Condenser Assy.	1
30	4516788	Painted Top Cover Assy.	1
31	4523141	Nut M10 for fan	1
32	4516758	Left Handle	1
33	4517028	Guard Net Painting Assy.	1
34	4517772	Right Handle	1
38	464860026	Valve Plate Paint Assy.	1
39	4526396	Choke Assy.	1
40	467300039R	Filter PCB	1
42	452813100	Liquid-Gas Separator	1
43	467300038R	MSMP PCB	1
44	463650003	Manifold Assy.	1
45	463700004	Distributing Pipe Assy.	1
46	464860027	Painted Stop Plate Assy.	1
47	453225700	OAT Support	1
48	452783501	Brass Connector with Flange 3/8"	3
48	452783502	Brass Connector with Flange 1/4"	3
49	463250001	Liquid Accumulator	1

APPENDIX A

INSTALLATION AND OPERATION MANUAL

- ▶ **INSTALLATION MANUAL TRIO DELTA 5.2kw DCI**