



Service Manual

Alpha SP Series

Indoor Units	Outdoor Units
Alpha 9 SP R22	CSP 9 R22
Alpha 12 SP R22	CSP 12 R22
Alpha 9 SP EU R410A	CSP 9 R410A EU
Alpha 12 SP EU R410A	CSP 12 R410A EU
Alpha 9 SP ISR R410A	CSPI 9 R410A RC
	CSPI 9 R410A A2 RC
Alpha 12 SP ISR R410A	CSPI 12 R410A RC
	CSPI 12 R410A A2 RC



REFRIGERANT

R22

R410A

COOLING ONLY

HEAT PUMP

LIST OF EFFECTIVE PAGES

Note: Changes in the pages are indicated by a “Revision#” in the footer of each effected page (when none indicates no changes in the relevant page). All pages in the following list represent effected/ non effected pages divided by chapters.

Dates of issue for original and changed pages are:

Original 0 March 2007

Total number of pages in this publication is 137 consisting of the following:

Page No.	Revision No. #		Page No.	Revision No. #		Page No.	Revision No. #
----------	----------------	--	----------	----------------	--	----------	----------------

Title 2
 A 2
 i 2
 1-1 - 1-3 2
 2-1 - 2-8 2
 3-1 2
 4-1 - 4-4 2
 5-1 - 5-32 2
 6-1 - 6-6 2
 7-1 2
 8-1 - 8-2 2
 9-1 2
 10-1-10-2 2
 11-1 2
 12-1-12-31 2
 13-1-13-2 2
 14-1-14-28 2
 Appendix -A 2

- Zero in this column indicates an original page.

*Due to constant improvements please note that the data on this service manual can be modified with out notice.

**Photos are not contractual

Table of Contents

1.	INTRODUCTION	1-1
2.	PRODUCT DATA SHEET	2-1
3.	RATING CONDITIONS	3-1
4.	OUTLINE DIMENSIONS	4-1
5.	PERFORMANCE DATA & PRESSURE CURVES	5-1
6.	SOUND LEVEL CHARACTERISTICS	6-1
7.	ELECTRICAL DATA.....	7-1
8.	WIRING DIAGRAMS	8-1
9.	ELECTRICAL CONNECTIONS.....	9-1
10.	REFRIGERATION DIAGRAMS.....	10-1
11.	TUBING CONNECTIONS.....	11-1
12.	CONTROL SYSTEM	12-1
13.	TROUBLESHOOTING	13-1
14.	EXPLODED VIEWS AND SPARE PARTS LISTS.....	14-1
15.	APPENDIX A	15-1

1. INTRODUCTION

1.1 General

The new **Alpha** split wall mounted basic on compact indoor and outdoor unit, it range comprise the ST (cooling only) and RC (heat pump) models, as follows:

- **Cooling Only:**

ASP 9 410A (Flat,DF) ST / CSP 9 R410A ST;
ASP 12 R410A (Flat, DF) ST / CSP 12 R410A ST;
ASP 9 R22 (Flat,DF) ST / CSP 9 R22 ST;
ASP 12 R22 (Flat, DF) ST / CSP 12 R22 ST.

- **Heat Pump:**

ASP 9 R410A (Flat,DF) RC / CSP 9 R410A RC;
ASP 12 R410A (Flat, DF) RC / CSP 12 R410A RC;
ASP 9 R22 (Flat,DF) RC / CSP 9 R22 RC
ASP 12 R22 (Flat, DF) RC / CSP 12 R22 RC.

The indoor **Alpha SP** units are available as LED display types only, featuring esthetic design, compact dimensions, and low noise operation.

Display type models availability:

- **LED Type: ASP 9 R410A (Flat, DF), ASP 12 R410A (Flat, DF).**

1.2 Main Features

The **Alpha SP** series benefits from the most advanced technological innovations, namely:

- R410A/R22 models.
- Microprocessor control.
- Infrared remote control with liquid crystal display.
- Supports Indoor Air Quality features, such as –.
- Indoor large diameter cross flow fan, allowing low noise level operation.
- Bended indoor coil with treated aluminum fins and coating for improved efficiency.
- Easy access to the interconnecting tubing and wiring connections, so that removing the front grill or casing is not necessary.
- Refrigerant pipes can be connected to the indoor unit from 5 different optional directions.
- Automatic treated air sweep.
- Low indoor and outdoor noise levels.
- Easy installation and service.
- New package design for indoor unit, it should be based on open sleeve and open sides
- Installation manual to be printed on one page with back and front printing
- One RC simply manual printing on two side as the standard

1.3 Indoor Unit

The indoor unit is wall mounted, and can be easily fitted to many types of residential and commercial applications.

It includes:

- Casing with air inlet and outlet grills.
- A large-diameter tangential fan.
- Bended coil with treated aluminum fins.
- Motorized flaps
- Multi-speed motor with internal protection
- Advanced electronic control box assembly
- Interconnecting wiring terminal block
- Mounting plate

1.4 Filtration

The **Alpha SP** series presents only one type of air filters:

- Easily accessible, and re-usable pre-filters (mesh)

1.5 Control

The microprocessor indoor controller, and an infrared remote control, supplied as standard, provide complete operating function and programming. For further details please refer to the Operation Manual, Appendix A.

1.6 Outdoor Unit

The **Alpha SP** outdoor units can be installed as floor or wall mounted units by using a wall supporting bracket. The metal sheets are protected by anti-corrosion paint work allowing long life resistance. All outdoor units are pre-charged. For further information please refer to the Product Data Sheet, Chapter 2.

It includes :

- Compressor mounted in a soundproofed compartment :

Rotary – for CSP 9 R410A (R22)ST/RC, CSP 12 R410A (R22) ST/RC

- Axial fan.
- Outdoor coil with hydrophilic louver fins for RC units.
- Outlet air fan grill.
- Interconnecting wiring terminal block.

1.7 Tubing Connections

Flare type interconnecting tubing to be produced on site.
For further details please refer to the Installation Manual, Outdoor Chapter 3.

1.8 Inbox Documentation

Each unit is supplied with its own installation and operation manuals, one simply remote control manual Matching Table

1.9 Matching Table

1.9.1 R410A

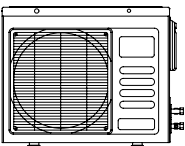
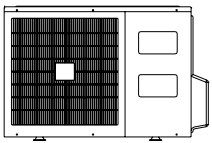
OUTDOOR UNITS			INDOOR UNITS			
						
MODEL	REFRIGER.	ASP9 R410A EU	ASP9 R410A ISR	ASP12 R410A EU	ASP12 R410A ISR	
	CSP 9 EU	R410A	√			
	CSP 9 ISR	R410A		√		
	CSP 12 EU	R410A			√	
	CSP 12 ISR	R410A			√	

1.9.2 R22

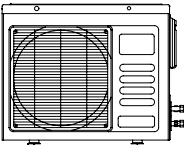
OUTDOOR UNITS			INDOOR UNITS	
				
MODEL	REFRIGER.	ASP 9 R22	ASP 12 R22	
	CSP 9	R22	√	
	CSP 12	R22		√

2. PRODUCT DATA SHEET

2.1 Alpha 9 SP R22 / CSP 9 R22

Model Indoor Unit			ASP 9(ASP FLAT,ASP DF)		
Model Outdoor Unit			CSP 9		
Installation Method of Pipe			Flared		
Characteristics	Units		Cooling Only	Cooling	Heating
Capacity ⁽⁴⁾	Btu/hr		8770	8770	9550
	kW		2.57	2.57	2.80
Power input ⁽⁴⁾	kW		0.94	0.94	0.85
EER (Cooling) or COP(Heating) ⁽⁴⁾	W/W		2.73	2.73	3.30
Energy efficiency class			D	D	C
Power supply	V		220-230		
	Ph		1		
	Hz		50		
Rated current	A		4.4	4.4	4.0
Power factor			0.95	0.95	0.95
Prated (IDU)	W		27		
Prated (IDU+ODU)	W		1090		
Starting current	A		26		
Circuit breaker rating	A		10		
INDOOR	Fan type & quantity		Crossflow x 1		
	Fan speeds	H/M/L	RPM	1250/-/1050	
	Air flow ⁽¹⁾	H/M/L	m3/hr	450/-/350	
	External static pressure	Min	Pa	0	
	Sound power level ⁽²⁾	H/M/L	dB(A)	52/-/48	
	Sound pressure level ⁽³⁾	H/M/L	dB(A)	40/-/35	
	Moisture removal		l/hr	1	
	Condensate drain tube I.D		mm	16	
	Dimensions	WxHxD	mm	680*180*250	
	Net Weight		kg	6	
	Package dimensions	WxHxD	mm	740x310x248	
	Packaged weight		kg	8.5	
	Units per pallet		units	36	
	Stacking height		units	9 levels	
	OUTDOOR	Refrigerant control		Capillary tube	
Compressor type,model		Rotary,TOSHIBA PH170X1C-4DZDE3			
Fan type & quantity		Propeller(direct) x 1			
Fan speeds		H	RPM	900	
Air flow		H	m3/hr	1265	
Sound power level		H	dB(A)	62	63
Sound pressure level ⁽³⁾		H	dB(A)	52	53
Dimensions		WxHxD	mm	610x520x240	
Net Weight			kg	26	26.5
Package dimensions		WxHxD	mm	725*550*355	
Packaged weight			kg	29	29.5
Units per pallet			Units	12	
Stacking height			units	4 levels	
Refrigerant type		R22			
Refrigerant chargeless distance		kg(4m)	0.63kg		
Additional charge			4m<Lin<8m:+5g/m; Lin>8m:+15g/m		
Connections between units	Liquid line	In.(mm)	1/4"(6.35)		
	Suction line	In.(mm)	3/8"(9.53)		
	Max.tubing length	m.	Max.15		
	Max.height difference	m.	Max.7		
Operation control type			Remote control		
Heating elements (Option)		kW			
Others					

⁽¹⁾Airflow in ducted units;at nominal external static pressure.

⁽²⁾Sound power in ducted units is measured at air discharge.

⁽³⁾Sound pressure level measured at 1-meter distance from unit.

⁽⁴⁾Rating conditions in accordance to ISO 5151 and ISO 13253 (for ducted units).

⁽⁵⁾Declaration tolerance is in accordance with EN14511.

2.2 Alpha 12 SP R22 / CSP 12 R22

Model Indoor Unit			ASP 12(ASP FLAT,ASP DF)		
Model Outdoor Unit			CSP 12		
Installation Method of Pipe			Flared		
Characteristics		Units	Cooling Only	Cooling	Heating
Capacity ⁽⁴⁾		Btu/hr	10920	10920	11940
		kW	3.20	3.20	3.50
Power input ⁽⁴⁾		kW	1.14	1.14	1.06
EER (Cooling) or COP(Heating) ⁽⁴⁾		W/W	2.81	2.81	3.30
Energy efficiency class			C	C	C
Power supply		V	220-230		
		Ph	1		
		Hz	50		
Rated current		A	5.2	5.2	4.9
Power factor			0.95	0.95	0.95
Prated (IDU)		W	30		
Prated (IDU+ODU)		W	1425	1446	
Starting current		A	28		
Circuit breaker rating		A	10		
INDOOR	Fan type & quantity			Crossflow x 1	
	Fan speeds	H/M/L	RPM	1250/-/1000	
	Air flow ⁽¹⁾	H/M/L	m3/hr	650/-/500	
	External static pressure	Min	Pa	0	
	Sound power level ⁽²⁾	H/M/L	dB(A)	55/-/49	
	Sound pressure level ⁽³⁾	H/M/L	dB(A)	41/-/34	
	Moisture removal		l/hr	1.1	
	Condensate drain tube I.D		mm	16	
	Dimensions	WxHxD	mm	840x250x180	
	Net Weight		kg	7	
	Package dimensions	WxHxD	mm	900x310x248	
	Packaged weight		kg	9.5	
	Units per pallet		units	36	
	Stacking height		units	9 levels	
OUTDOOR	Refrigerant control			Capillary tube	
	Compressor type,model			Rotary,Sanyo,C-RV212H51BA	
	Fan type & quantity			Propeller(direct) x 1	
	Fan speeds	H	RPM	900	
	Air flow	H	m3/hr	1200	
	Sound power level	H	dB(A)	63	65
	Sound pressure level ⁽³⁾	H	dB(A)	52	54
	Dimensions	WxHxD	mm	610x520x240	
	Net Weight		kg	29.5	30
	Package dimensions	WxHxD	mm	725x550x355	
	Packaged weight		kg	31.5	32
	Units per pallet		Units	12	
	Stacking height		units	4 levels	
	Refrigerant type			R22	
	Refrigerant chargless distance		kg(7.5m)	0.88kg/7.5m	
	Additional charge			4m≤Length≤10m: +0g; 10m Length≤15m: +100g	
Connections between units	Liquid line	In.(mm)	1/4"(6.35)		
	Suction line	In.(mm)	1/2"(12.7)		
	Max.tubing length	m.	Max.15		
	Max.height difference	m.	Max.7		
Operation control type			Remote control		
Heating elements		kW			
Others					

⁽¹⁾Airflow in ducted units; at nominal external static pressure.
⁽²⁾Sound power in ducted units is measured at air discharge.
⁽³⁾Sound pressure level measured at 1-meter distance from unit.
⁽⁴⁾Rating conditions in accordance to ISO 5151 and ISO 13253 (for ducted units).
⁽⁵⁾Declaration tolerance is in accordance with EN14511.

2.3 Alpha 9 SP EU R410A / CSP 9 EU R410A

Model Indoor Unit		ASP 9 R410A flat for EU			
Model Outdoor Unit		CSP 9 R410A for EU			
Installation Method of Pipe		Flared			
Characteristics		Units	Cooling Only	Cooling	Heating
Capacity ⁽⁴⁾		Btu/hr	8700	8700	9040
		kW	2.55	2.55	2.65
Power input ⁽⁴⁾		kW	0.89	0.89	0.82
EER (Cooling) or COP(Heating) ⁽⁴⁾		W/W	2.84	2.84	3.22
Energy efficiency class			C	C	C
Power supply		V	220-230		
		Ph	1		
		Hz	50		
Rated current		A	4.0	4.0	3.7
Power factor		W	0.97	0.97	0.97
Prated(IDU)		W	30		
Prated(IDU+ODU)		W	1072	1072	
Starting current		A	16.5		
Circuit breaker rating		A	10		
INDOOR	Fan type & quantity			Crossflow x 1	
	Fan speeds	H/M/L	RPM	1310/-/1100	
	Air flow ⁽¹⁾	H/M/L	m3/hr	450/-/360	
	External static pressure	Min	Pa	0	
	Sound power level ⁽²⁾	H/M/L	dB(A)	53/-/49	
	Sound pressure level ⁽³⁾	H/M/L	dB(A)	41/-/35	
	Moisture removal		l/hr	0.9	
	Condensate drain tube I.D		mm	16	
	Dimensions	WxHxD	mm	680x250x180	
	Net Weight		kg	6	
	Package dimensions	WxHxD	mm	740x310x248	
	Packaged weight		kg	8.5	
	Units per pallet		units	36	
	Stacking height		units	9 levels	
	OUTDOOR	Refrigerant control			Capillary tube
Compressor type,model			Rotary,Sanyo(Hua Run),C-1RV107		
Fan type & quantity			Propeller(direct) x 1		
Fan speeds		H	RPM	900	
Air flow		H	m3/hr	1200	
Sound power level		H	dB(A)	62	62
Sound pressure level ⁽³⁾		H	dB(A)	51	51
Dimensions		WxHxD	mm	610x520x240	
Net Weight			kg	23.5	24
Package dimensions		WxHxD	mm	725x550x355	
Packaged weight			kg	26	26.5
Units per pallet			Units	12	
Stacking height			units	4 levels	
Refrigerant type				R410A	
Standard charge			kg(7.5m)	0.58kg	
Additional charge			4m≤Length≤10m: +0g; 10m≤Length≤15m: +50g		
Connections between units	Liquid line	In.(mm)	1/4"(6.35)		
	Suction line	In.(mm)	3/8"(9.53)		
	Max.tubing length	m.	Max.15		
	Max.height difference	m.	Max.7		
Operation control type			Remote control		
Heating elements		kW	Remote control(RC-5)		
Others					

⁽¹⁾Airflow in ducted units; at nominal external static pressure.
⁽²⁾Sound power in ducted units is measured at air discharge.
⁽³⁾Sound pressure level measured at 1-meter distance from unit.
⁽⁴⁾Rating conditions in accordance to ISO 5151 and ISO 13253 (for ducted units).
⁽⁵⁾Declaration tolerance is in accordance with EN14511.

2.4 Alpha 12 SP EU R410A / CSP 12 SP EU R410A

Model Indoor Unit		ASP 12 R410A (Flat) for EU		
Model Outdoor Unit		CSP 12 R410A for EU		
Installation Method of Pipe		Flared		
Characteristics	Units	Cooling Only	Cooling	Heating
Capacity ⁽⁴⁾	Btu/hr	11260	11260	11600
	kW	3.30	3.30	3.40
Power input ⁽⁴⁾	kW	1.16	1.16	1.05
EER (Cooling) or COP(Heating) ⁽⁴⁾	W/W	2.84	2.84	3.22
Energy efficiency class		C	C	C
Power supply	V	220-230		
	Ph	1		
	Hz	50		
Rated current	A	5.13	5.13	4.65
Power factor		0.98	0.98	0.98
Prated(IDU)	W	30		
Prated(IDU+ODU)	W	1295	1440	
Starting current	A	28		
Circuit breaker rating	A	10		
INDOOR	Fan type & quantity		Crossflow x 1	
	Fan speeds	H/M/L	RPM	1250/-/1000
	Air flow ⁽¹⁾	H/M/L	m3/hr	650/-/500
	External static pressure	Min	Pa	0
	Sound power level ⁽²⁾	H/M/L	dB(A)	55/-/49
	Sound pressure level ⁽³⁾	H/M/L	dB(A)	41-/34
	Moisture removal		l/hr	1.1
	Condensate drain tube I.D		mm	16
	Dimensions	WxHxD	mm	840x250x180
	Net Weight		kg	7
	Package dimensions	WxHxD	mm	900x310x248
	Packaged weight		kg	9.5
	Units per pallet		units	36
	Stacking height		units	9 levels
OUTDOOR	Refrigerant control		Capillary tube	
	Compressor type,model		Rotary,Sanyo(Hua Run),C-RV133H1D	
	Fan type & quantity		Propeller(direct) x 1	
	Fan speeds	H	RPM	900
	Air flow	H	m3/hr	1200
	Sound power level	H	dB(A)	63
	Sound pressure level ⁽³⁾	H	dB(A)	53
	Dimensions	WxHxD	mm	610x520x240
	Net Weight		kg	29
	Package dimensions	WxHxD	mm	725x550x355
	Packaged weight		kg	31
	Units per pallet		Units	12
	Stacking height		units	4 levels
	Refrigerant type		R410A	
	Standard charge		0.89kg	
	Additional charge		4m≤Length≤10m: +0g; 10m Length≤15m: +50g	
Connections between units	Liquid line	In.(mm)	1/4"(6.35)	
	Suction line	In.(mm)	3/8"(9.53)	
	Max.tubing length	m.	Max.15	
	Max.height difference	m.	Max.7	
Operation control type		Remote control		
Heating elements		kW	Remote control(RC-5)	
Others				

⁽¹⁾Airflow in ducted units; at nominal external static pressure.
⁽²⁾Sound power in ducted units is measured at air discharge.
⁽³⁾Sound pressure level measured at 1-meter distance from unit.
⁽⁴⁾Rating conditions in accordance to ISO 5151 and ISO 13253 (for ducted units).
⁽⁵⁾Declaration tolerance is in accordance with EN14511.

2.5 Alpha 9 SP ISR R410A / CSPI 9 R410A RC A1

Model Indoor Unit			ASP 9 R410A(ASP FLAT, ASP DF) FOR ISRAEL		
Model Outdoor Unit			CSPI 9 R410A RC		
Installation Method of Pipe			Flared		
Characteristics		Units	Cooling	Heating	
Capacity ⁽⁴⁾			8900	9550	
			kW	2.60	
Power input ⁽⁴⁾			0.81	0.80	
EER (Cooling) or COP(Heating) ⁽⁴⁾			3.20	3.50	
Energy efficiency class(SII)			C	C	
Power supply	V		230		
	Ph		1		
	Hz		50		
Rated current	A		3.7	3.6	
Power factor			0.95	0.95	
Prated (IDU)	W		30		
Prated (IDU+ODU)	W		1185		
Starting current	A		16.5		
Circuit breaker rating	A		10		
INDOOR	Fan type & quantity		Crossflow x 1		
	Fan speeds	H/M/L	RPM	1310/-/1100	
	Air flow ⁽¹⁾	H/M/L	m3/hr	450/-/360	
	External static pressure	Min	Pa	0	
	Sound power level ⁽²⁾	H/M/L	dB(A)	53/-/49	
	Sound pressure level ⁽³⁾	H/M/L	dB(A)	41/-/35	
	Moisture removal			l/hr	0.9
	Condensate drain tube I.D			mm	16
	Dimensions	WxHxD	mm	680x250x180	
	Net Weight			kg	6
	Package dimensions	WxHxD	mm	740x310x248	
	Packaged weight			kg	8.5
	Units per pallet			units	36
	Stacking height			units	9 levels
OUTDOOR	Refrigerant control		Capillary tube		
	Compressor type,model		Rotary,Sanyo,C-1RV107		
	Fan type & quantity		Propeller(direct) x 1		
	Fan speeds	H	RPM	900	
	Air flow	H	m3/hr	1200	
	Sound power level	H	dB(A)	62	
	Sound pressure level ⁽³⁾	H	dB(A)	52	
	Dimensions	WxHxD	mm	610x520x240	
	Net Weight			kg	26.5
	Package dimensions	WxHxD	mm	725x550x355	
	Packaged weight			kg	28.5
	Units per pallet			Units	12
	Stacking height			units	4 levels
	Refrigerant type		R410A		
	Refrigerant chargless distance		kg(7.5m)	0.80kg	
	Additional charge		4m≤Length≤10m: +0g; 10m Length≤15m: +50g		
	Connections between units	Liquid line	In.(mm)	1/4"(6.35)	
Suction line		In.(mm)	3/8"(9.53)		
Max.tubing length		m.	Max.15		
Max.height difference		m.	Max.7		
Operation control type		Remote control			
Heating elements		kW			
Others					

⁽¹⁾Airflow in ducted units;at nominal external static pressure.

⁽²⁾Sound power in ducted units is measured at air discharge.

⁽³⁾Sound pressure level measured at 1-meter distance from unit.

⁽⁴⁾Rating conditions in accordance to ISO 5151 and ISO 13253 (for ducted units).

2.6 Alpha 12 SP ISR R410A / CSPI 12 R410A RC A1

Model Indoor Unit		ASP 12 R410A(ASP FLAT,ASP DF) FOR ISRAEL		
Model Outdoor Unit		CSPI 12 R410A RC		
Installation Method of Pipe		Flared		
Characteristics		Units	Cooling Heating	
Capacity ⁽⁴⁾		Btu/hr	11600 12300	
		kW	3.40 3.60	
Power input ⁽⁴⁾		kW	1.11 1.16	
EER (Cooling) or COP(Heating) ^{tt}		W/W	3.05 3.10	
Energy efficiency class(SII)			F F	
Power supply		V	230	
		Ph	1	
		Hz	50	
Rated current		A	5.0 5.3	
Power factor			0.95 0.95	
Prated (IDU)		W	30	
Prated (IDU+ODU)		W	1405	
Starting current		A	28	
Circuit breaker rating		A	10	
INDOOR	Fan type & quantity		Crossflow x 1	
	Fan speeds	H/M/L	RPM	1250/-/1000
	Air flow ⁽¹⁾	H/M/L	m3/hr	630/-/480
	External static pressure	Min	Pa	0
	Sound power level ⁽²⁾	H/M/L	dB(A)	55/-/50
	Sound pressure level ⁽³⁾	H/M/L	dB(A)	41/-/36
	Moisture removal		l/hr	1.1
	Condensate drain tube I.D		mm	16
	Dimensions	WxHxD	mm	840x250x180
	Net Weight		kg	7
	Package dimensions	WxHxD	mm	900x310x248
	Packaged weight		kg	9.5
	Units per pallet		units	36
	Stacking height		units	9 levels
	OUTDOOR	Refrigerant control		Capillary tube
Compressor type,model		Rotary,Sanyo,C-RV133H1D		
Fan type & quantity		Propeller(direct) x 1		
Fan speeds		H	RPM	735
Air flow		H	m3/hr	1450
Sound power level		H	dB(A)	65
Sound pressure level ⁽³⁾		H	dB(A)	54
Dimensions		WxHxD	mm	760x545x245
Net Weight			kg	32.5
Package dimensions		WxHxD	mm	870x600x320
Packaged weight			kg	35
Units per pallet			Units	12
Stacking height			units	3 levels
Refrigerant type				R410A
Refrigerant chargless distance			kg(7.5m)	0.91kg
Additional charge			4m≤Length≤10m: +0g; 10m Length≤15m: +50g	
Connections between units	Liquid line	In.(mm)	1/4"(6.35)	
	Suction line	In.(mm)	3/8"(9.53)	
	Max.tubing length	m.	Max.15	
	Max.height difference	m.	Max.7	
Operation control type			Remote control	
Heating elements (Option)		kW		
Others				

⁽¹⁾Airflow in ducted units;at nominal external static pressure.

⁽²⁾Sound power in ducted units is measured at air discharge.

⁽³⁾Sound pressure level measured at 1-meter distance from unit.

⁽⁴⁾Rating conditions in accordance to ISO 5151 and ISO 13253 (for ducted units).

2.7 ASP 9 R410A A2 ISR / CSPI 9 R410A A2 ISR

Model Indoor Unit		ASP 9 R410A A2 ISR	
Model Outdoor Unit		CSPI 9 R410A A2 ISR	
Installation Method of Pipe		Flared	
Characteristics		Units	Cooling
			Heating
Capacity (4)		Btu/hr	9380
		kW	2.75
Power input (4)		kW	0.8
EER (Cooling) or COP(Heating) (4)		W/W	3.46
Energy efficiency class(SII)			E
Power supply		V	230
		Ph	1
		Hz	50
Rated current		A	3.6
Power factor			0.95
Prated (IDU)		W	30
Prated (IDU+ODU)		W	970
Starting current		A	16.65
Circuit breaker rating		A	10
INDOOR	Fan type & quantity		Crossflow x 1
	Fan speeds	H/M/L	RPM
	Air flow (1)	H/M/L	m3/hr
	External static pressure	Min	Pa
	Sound power level (2)	H/M/L	dB(A)
	Sound pressure level(3)	H/M/L	dB(A)
	Moisture removal		l/hr
	Condensate drain tube I.D		mm
	Dimensions	WxHxD	mm
	Net Weight		kg
	Package dimensions	WxHxD	mm
	Packaged weight		kg
	Units per pallet		units
	Stacking height		units
	OUTDOOR	Refrigerant control	
Compressor type,model		Rotary,Toshiba(GMCC),PA103X1C-4FZDE1	
Fan type & quantity		Propeller(direct) x 1	
Fan speeds		H	RPM
Air flow		H	m3/hr
Sound power level		H	dB(A)
Sound pressure level(3)		H	dB(A)
Dimensions		WxHxD	mm
Net Weight			kg
Package dimensions		WxHxD	mm
Packaged weight			kg
Units per pallet			Units
Stacking height			units
Refrigerant type			R410A
Refrigerant chargeless distance			kg(7.5m)
Additional charge		4m≤Length≤10m: +0g; 10mLength≤15m: +50g	
Connections between units	Liquid line	In.(mm)	1/4"(6.35)
	Suction line	In.(mm)	3/8"(9.53)
	Max.tubing length	m.	Max.15
	Max.height difference	m.	Max.7
Operation control type			Remote control
Heating elements (Option)		kW	
Others			

- (1)Airflow in ducted units;at nominal external static pressure.
- (2)Sound power in ducted units is measured at air discharge.
- (3)Sound pressure level measured at 1-meter distance from unit.
- (4)Rating conditions in accordance to ISO 5151 and ISO 13253 (for ducted units).

2.8 ASP 12 R410A A2 ISR / CSPI 12 R410A A2 ISR

Model Indoor Unit			ASP 12 R410A A2 ISR	
Model Outdoor Unit			CSPI 12 R410A A2 ISR	
Installation Method of Pipe			Flared	
Characteristics		Units	Cooling	Heating
Capacity (4)		Btu/hr	11970	11970
		kW	3.51	3.51
Power input (4)		kW	1.04	1.00
EER (Cooling) or COP(Heating) (4)		W/W	3.38	3.50
Energy efficiency class(SII)			C	C
Power supply		V	230	
		Ph	1	
		Hz	50	
Rated current		A	4.7	4.6
Power factor			0.95	0.95
Prated (IDU)		W	30	
Prated (IDU+ODU)		W	1400	
Starting current		A	26	
Circuit breaker rating		A	10	
INDOOR	Fan type & quantity		Crossflow x 1	
	Fan speeds	H/M/L	RPM	1250/-/880
	Air flow (1)	H/M/L	m3/hr	620/-/390
	External static pressure	Min	Pa	0
	Sound power level (2)	H/M/L	dB(A)	53/-/47
	Sound pressure level(3)	H/M/L	dB(A)	40/-/33
	Moisture removal		l/hr	1.22
	Condensate drain tube I.D		mm	16
	Dimensions	WxHxD	mm	840x250x180
	Net Weight		kg	8
	Package dimensions	WxHxD	mm	900x310x248
	Packaged weight		kg	10.5
	Units per pallet		units	32
	Stacking height		units	8 levels
	OUTDOOR	Refrigerant control		Capillary tube
Compressor type,model		Rotary,Panasonic,5PS132EAC22		
Fan type & quantity		Propeller(direct) x 1		
Fan speeds		H	RPM	735
Air flow		H	m3/hr	1450
Sound power level		H	dB(A)	65
Sound pressure level(3)		H	dB(A)	54
Dimensions		WxHxD	mm	760x545x245
Net Weight			kg	32.5
Package dimensions		WxHxD	mm	870x600x320
Packaged weight			kg	35
Units per pallet			Units	12
Stacking height			units	3 levels
Refrigerant type				R410A
Refrigerant chargeless distance			kg(7.5m)	0.92kg
Additional charge			4m≤Length≤10m: +0g; 10mLength≤15m: +50g	
Connections between units	Liquid line	In.(mm)	1/4"(6.35)	
	Suction line	In.(mm)	3/8"(9.53)	
	Max.tubing length	m.	Max.15	
	Max.height difference	m.	Max.7	
Operation control type			Remote control	
Heating elements (Option)		kW		
Others				

(1)Airflow in ducted units;at nominal external static pressure.
 (2)Sound power in ducted units is measured at air discharge.
 (3)Sound pressure level measured at 1-meter distance from unit.
 (4)Rating conditions in accordance to ISO 5151 and ISO 13253 (for ducted units).

3. RATING CONDITIONS

Standard conditions in accordance with ISO 5151, ISO 13253 (for ducted units) and EN 14511.

Cooling:

Indoor: 27°C DB 19°C WB

Outdoor: 35°C DB

Heating:

Indoor: 20°C DB

Outdoor: 7°C DB 6°C WB

3.1 Operating Limits

3.1.1 R410A

		Indoor	Outdoor
Cooling	Upper limit	32°C DB 23°C WB	46°C DB
	Lower limit	21°C DB 15°C WB	10°C DB
Heating	Upper limit	27°C DB	24°C DB 18°C WB
	Lower limit	10°C DB	-9°C DB -10°C WB
Voltage		198 – 264 V	

3.1.2 R22

		Indoor	Outdoor
Cooling	Upper limit	32°C DB 23°C WB	46°C DB
	Lower limit	21°C DB 15°C WB	10°C DB
Heating	Upper limit	27°C DB	24°C DB 18°C WB
	Lower limit	10°C DB	-5°C DB -10°C WB
Voltage		198 – 264 V	

4. OUTLINE DIMENSIONS

4.1 Alpha SP 9

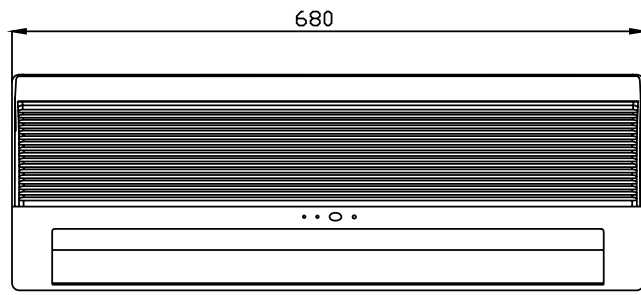
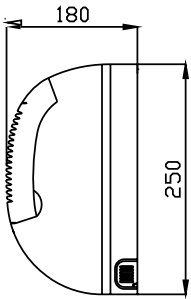
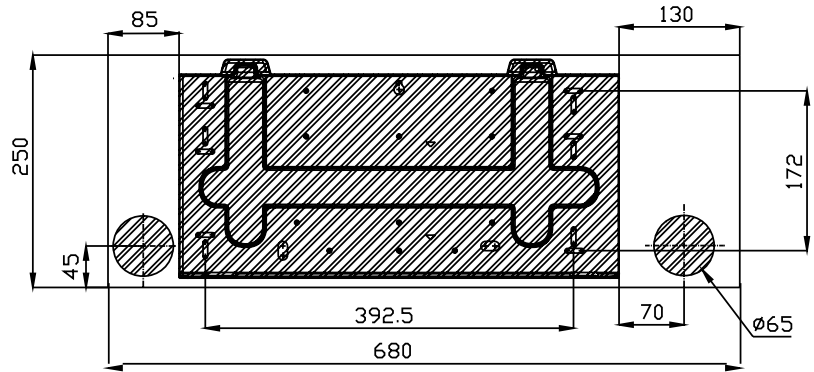

4.2 Alpha SP 12

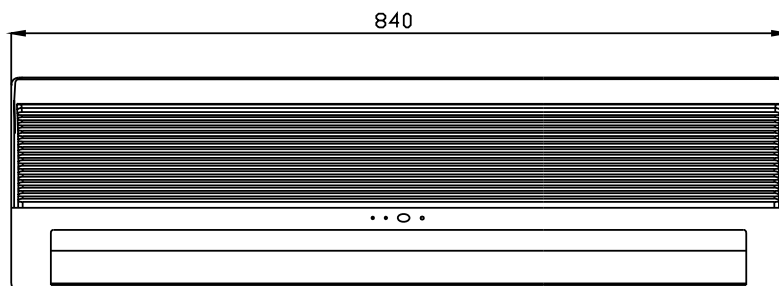
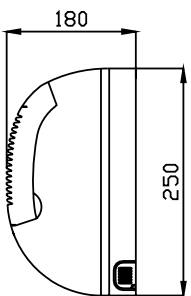
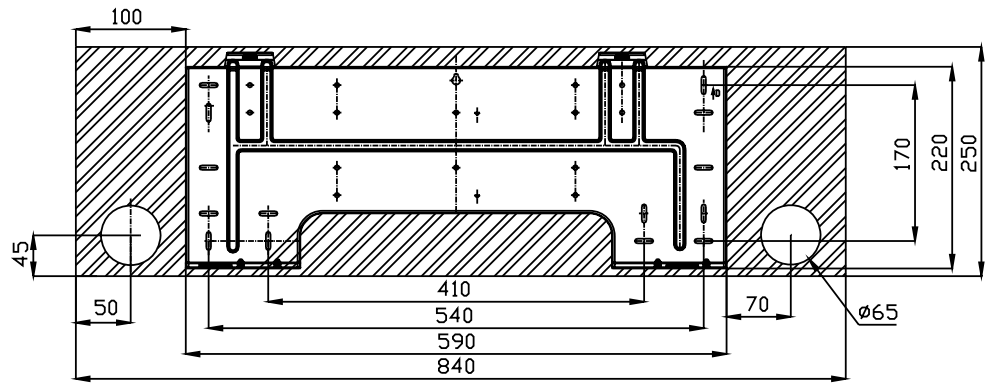

4.3 Alpha 7, 9 (Omega)

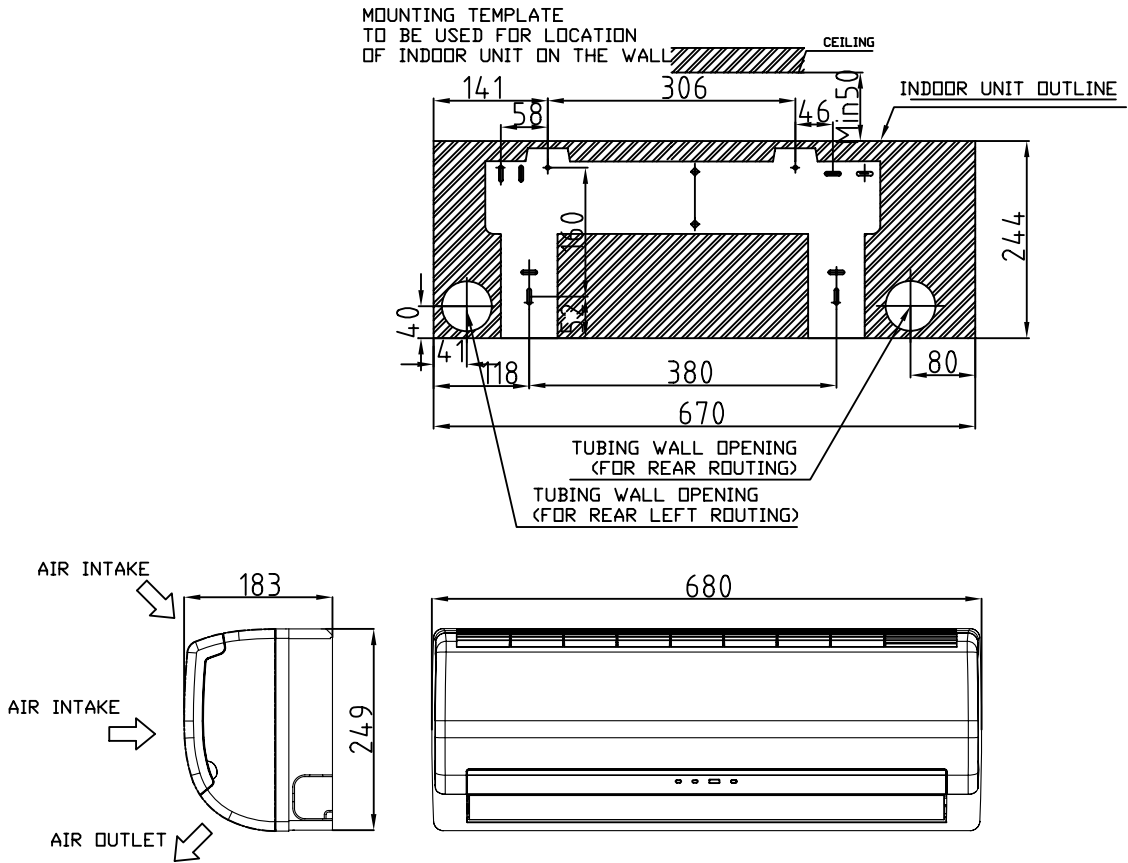

4.4 Alpha 12 (Omega)

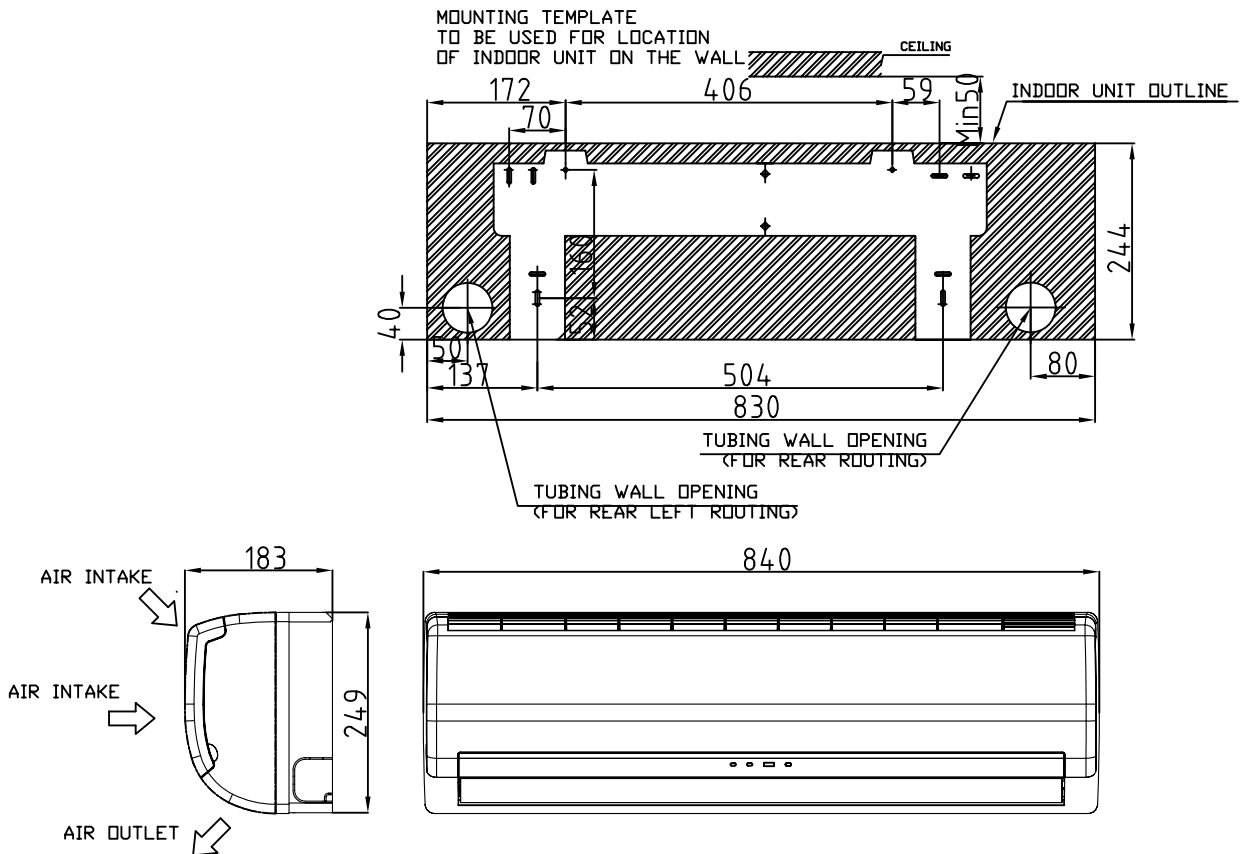

4.5 Alpha 9 DF

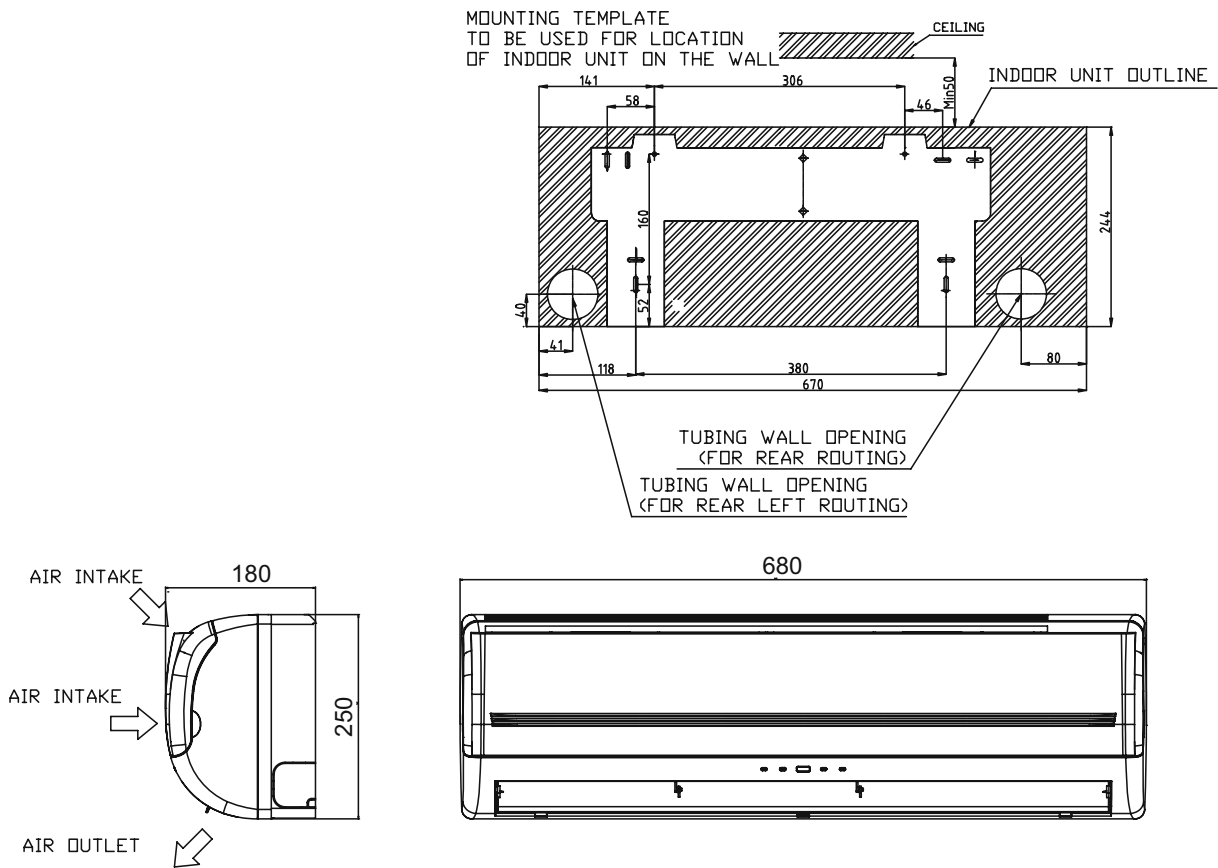

4.6 Alpha 12 DF

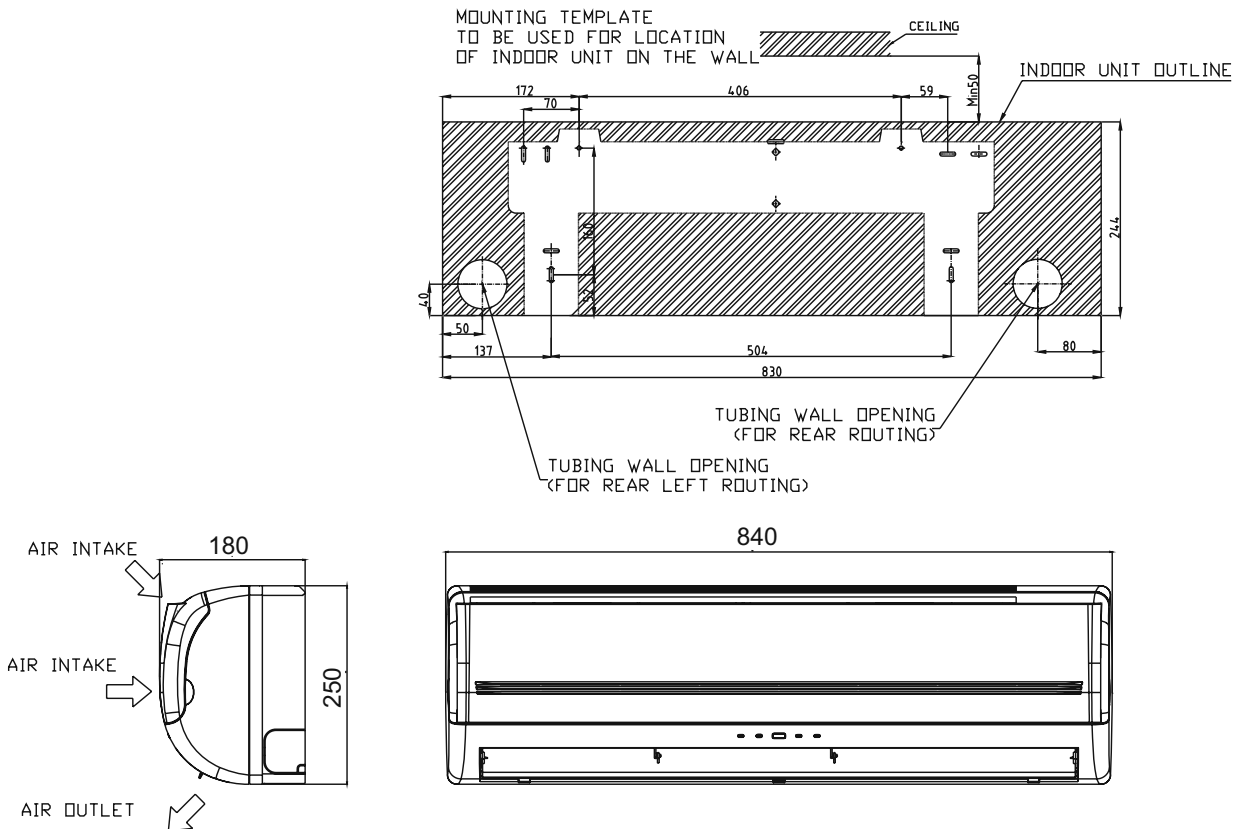

4.7 CSP9/12 R410A (EU), CSP(I)9 R410A, CSP9/12 R22 (CON9)

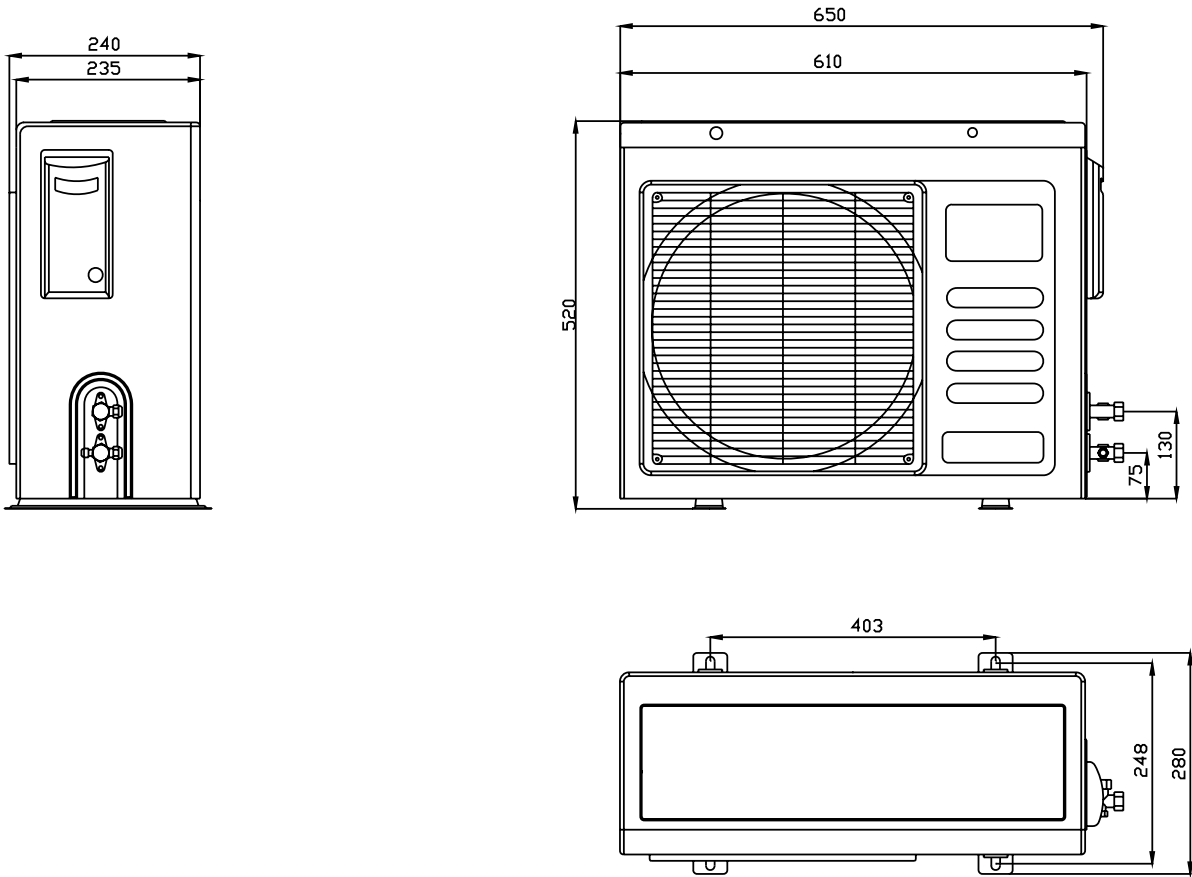

4.8 CSP(I)12 R410A (GCZ)

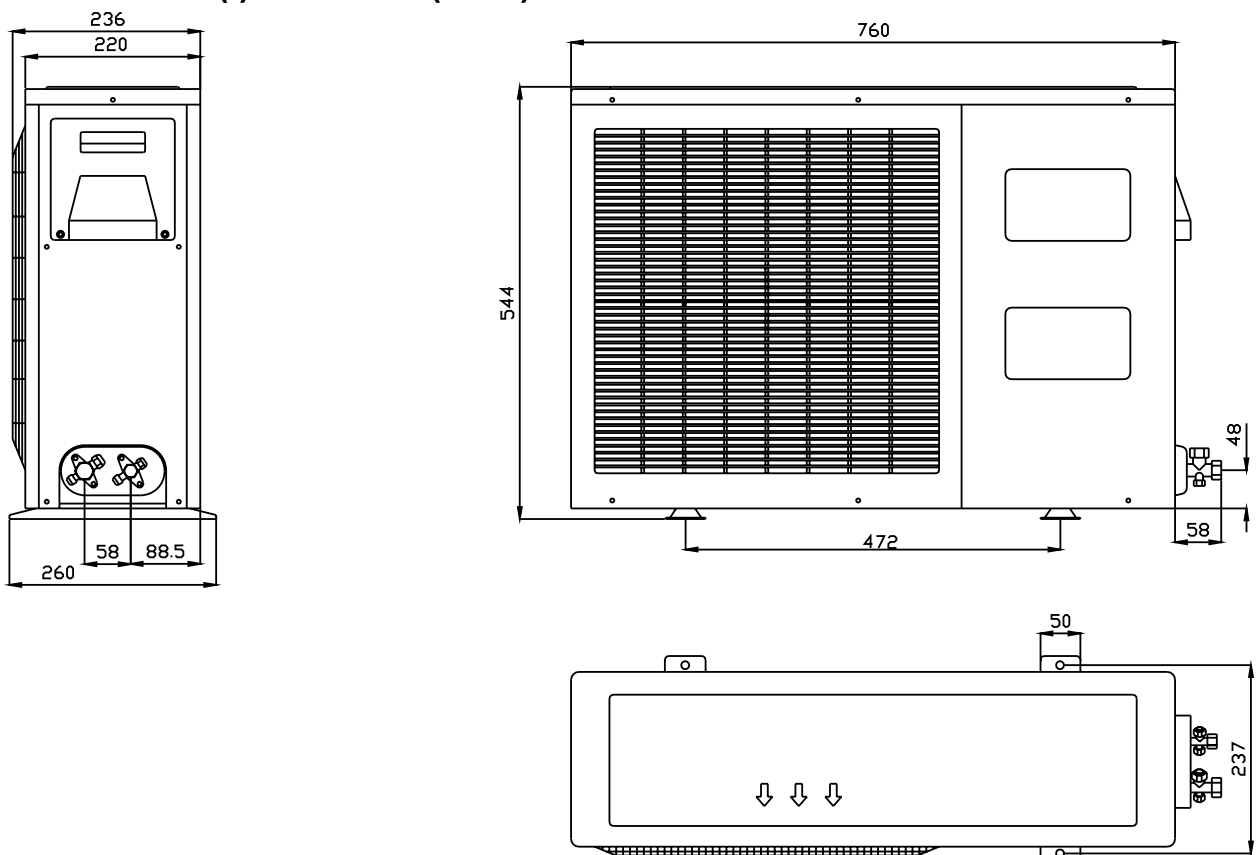

5. PERFORMANCE DATA & PRESSURE CURVES

5.1 Alpha9 SP/CSP9 R22

5.1.1 Cooling Mode at 7.5m Tubing Connection.

230V : Indoor Fan at High Speed.

Entering Air DB OD Coil(°C)	Data	Entering Air WB/DB ID Coil(°C)				
		15/21	17/24	19/27	21/29	23/32
15	TC	2.71	2.81	2.87	2.94	2.98
	SC	1.89	1.97	2.05	2.10	2.14
	PI	0.67	0.67	0.67	0.67	0.67
20	TC	2.62	2.76	2.85	2.92	2.98
	SC	1.85	1.95	2.04	2.09	2.13
	PI	0.72	0.73	0.73	0.73	0.73
25	TC	2.48	2.68	2.82	2.90	2.97
	SC	1.81	1.92	2.02	2.08	2.12
	PI	0.78	0.79	0.79	0.80	0.80
30	TC	2.32	2.53	2.73	2.82	2.91
	SC	1.75	1.86	1.98	2.03	2.07
	PI	0.84	0.86	0.86	0.87	0.88
35	TC	2.15	2.33	2.57	2.70	2.83
	SC	1.66	1.78	1.93	1.99	2.02
	PI	0.91	0.93	0.94	0.95	0.95
40	TC	1.95	2.13	2.32	2.54	2.67
	SC	1.57	1.69	1.83	1.88	1.92
	PI	0.98	1.00	1.01	1.03	1.04
46	TC	1.69	1.85	2.04	2.25	2.42
	SC	1.44	1.55	1.66	1.72	1.76
	PI	1.07	1.09	1.11	1.13	1.14

LEGEND

- TC – Total Cooling Capacity, kW
- SC – Sensible Capacity, kW
- PI – Power Input, kW
- WB – Wet Bulb Temp., (°C)
- DB – Dry Bulb Temp., (°C)
- ID – Indoor
- OD – Outdoor

(1) Marked area is below standard operating limits. For operating in low ambient conditions, an A.S.K Kit is required.

5.1.2 Heating

ENTERING WB OD COIL(°C)	ENTERING AIR DB ID COIL(°C)					
	15		20		25	
	TH	PI	TH	PI	TH	PI
-10	1.47	0.68	1.41	0.72	1.36	0.76
-7	1.58	0.70	1.53	0.74	1.47	0.78
-2	1.68	0.71	1.62	0.75	1.57	0.79
2	2.04	0.74	1.96	0.79	1.88	0.83
6	2.88	0.79	2.80	0.85	2.70	0.90
10	3.14	0.84	3.05	0.90	2.97	0.96
15	3.39	0.88	3.30	0.94	3.22	1.00
20	3.57	0.90	3.49	0.98	3.39	1.05

LEGEND

- TH – Total Heating Capacity, kW
- PI – Power Input, kW
- WB – Wet Bulb Temp., (°C)
- DB – Dry Bulb Temp., (°C)
- ID – Indoor
- OD – Outdoor

5.2 Model: Alpha9 SP/CSP9 R22

5.2.1 Cooling

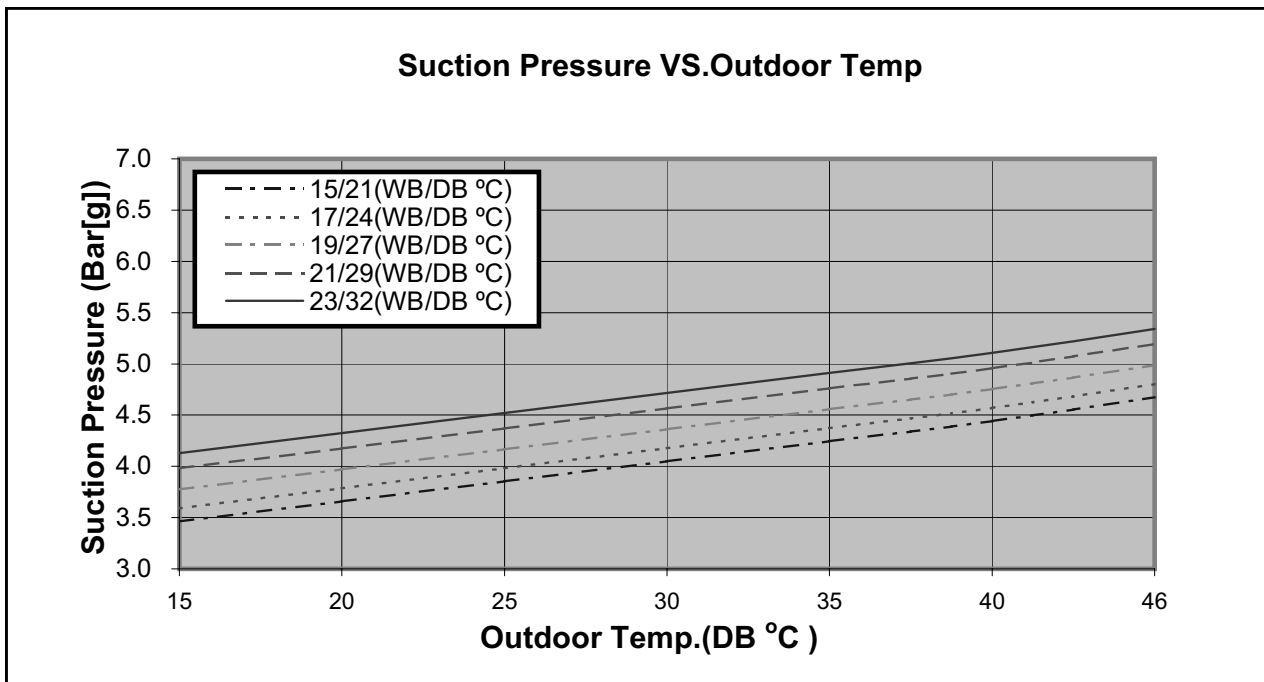
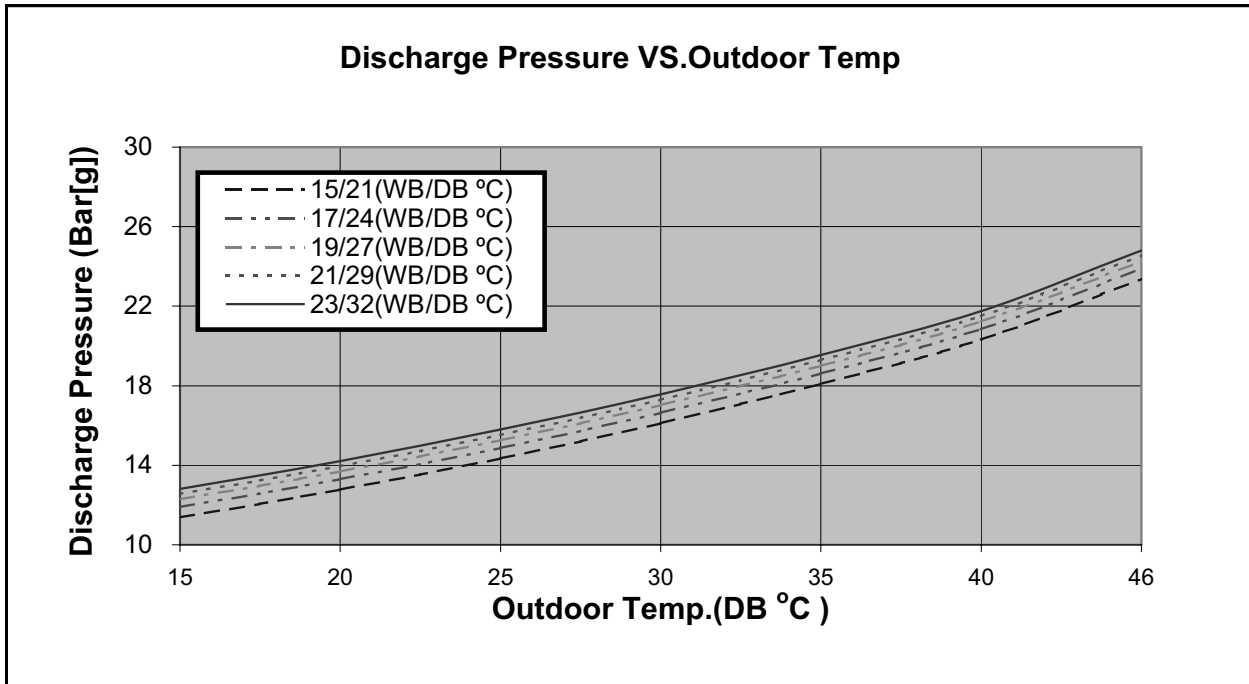

5.2.2 Heating

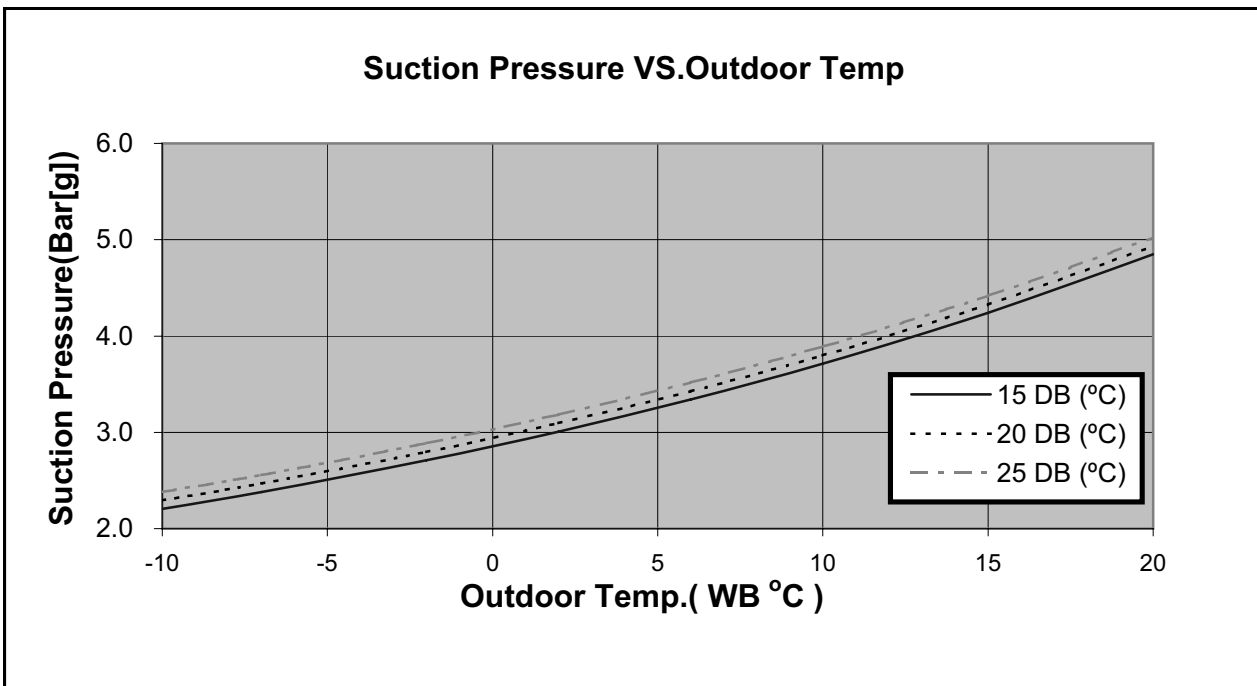
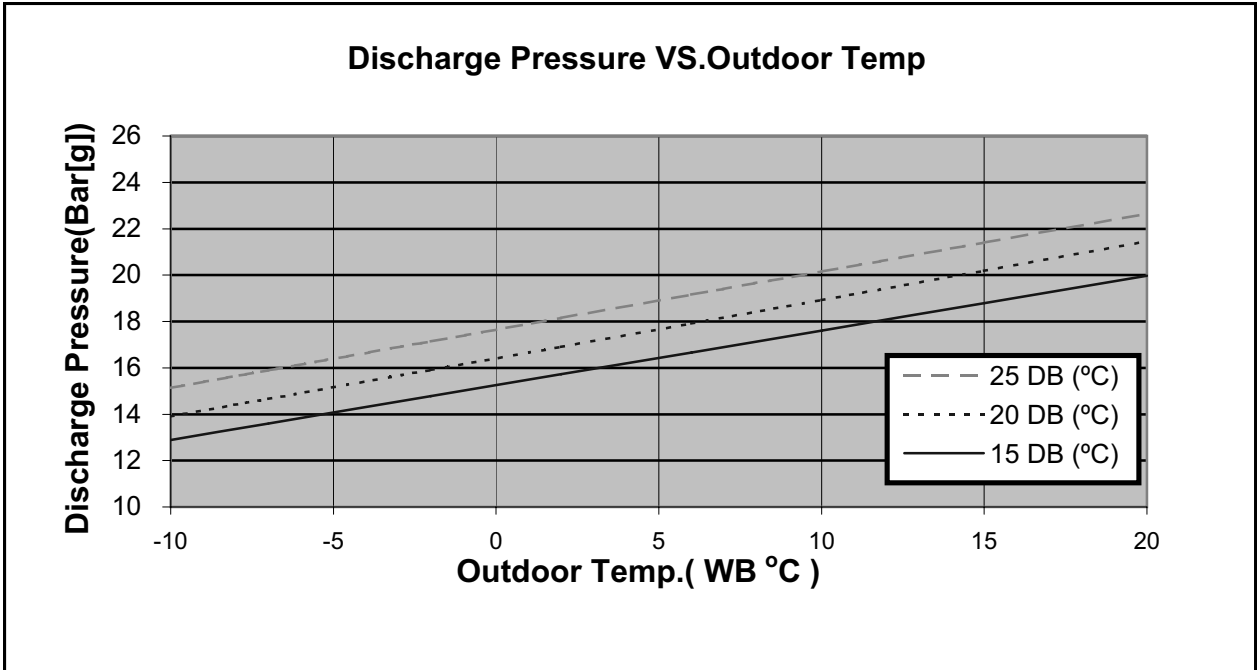

5.3 Alpha12 SP/CSP12 R22

5.3.1 Cooling Mode at 7.5m Tubing Connection.

230V : Indoor Fan at High Speed.

Entering Air DB OD Coil(°C)	Data	Entering Air WB/DB ID Coil(°C)				
		15/21	17/24	19/27	21/29	23/32
15	TC	3.37	3.49	3.58	3.66	3.72
	SC	2.35	2.45	2.55	2.61	2.66
	PI	0.81	0.81	0.81	0.81	0.82
20	TC	3.26	3.44	3.55	3.63	3.71
	SC	2.30	2.43	2.53	2.60	2.65
	PI	0.88	0.88	0.88	0.89	0.89
25	TC	3.09	3.33	3.51	3.61	3.70
	SC	2.24	2.38	2.51	2.58	2.63
	PI	0.95	0.95	0.96	0.97	0.97
30	TC	2.89	3.14	3.40	3.52	3.62
	SC	2.17	2.31	2.46	2.53	2.58
	PI	1.02	1.04	1.05	1.06	1.06
35	TC	2.67	2.90	3.20	3.36	3.52
	SC	2.07	2.22	2.40	2.47	2.52
	PI	1.10	1.12	1.14	1.15	1.16
40	TC	2.43	2.65	2.89	3.16	3.32
	SC	1.95	2.10	2.27	2.34	2.39
	PI	1.19	1.21	1.23	1.24	1.26
46	TC	2.11	2.31	2.54	2.80	3.02
	SC	1.79	1.92	2.07	2.14	2.19
	PI	1.30	1.32	1.35	1.37	1.38

LEGEND

- TC – Total Cooling Capacity, kW
- SC – Sensible Capacity, kW
- PI – Power Input, kW
- WB – Wet Bulb Temp., (°C)
- DB – Dry Bulb Temp., (°C)
- ID – Indoor
- OD – Outdoor

(1) Marked area is below standard operating limits. For operating in low ambient conditions, an A.S.K Kit is required.

5.3.2 Heating

ENTERING WB OD COIL(°C)	ENTERING AIR DB ID COIL(°C)					
	15		20		25	
	TH	PI	TH	PI	TH	PI
-10	1.84	0.85	1.77	0.90	1.70	0.95
-7	1.98	0.87	1.91	0.92	1.84	0.97
-2	2.10	0.88	2.03	0.93	1.96	0.99
2	2.56	0.92	2.45	0.98	2.35	1.04
6	3.61	0.99	3.50	1.06	3.38	1.13
10	3.92	1.05	3.82	1.12	3.71	1.20
15	4.24	1.09	4.13	1.18	4.03	1.25
20	4.46	1.12	4.36	1.22	4.24	1.31

LEGEND

- TH – Total Heating Capacity, kW
- PI – Power Input, kW
- WB – Wet Bulb Temp., (°C)_w
- DB – Dry Bulb Temp., (°C)
- ID – Indoor
- OD – Outdoor

5.4 Alpha12 SP/CSP12 R22

5.4.1 Cooling

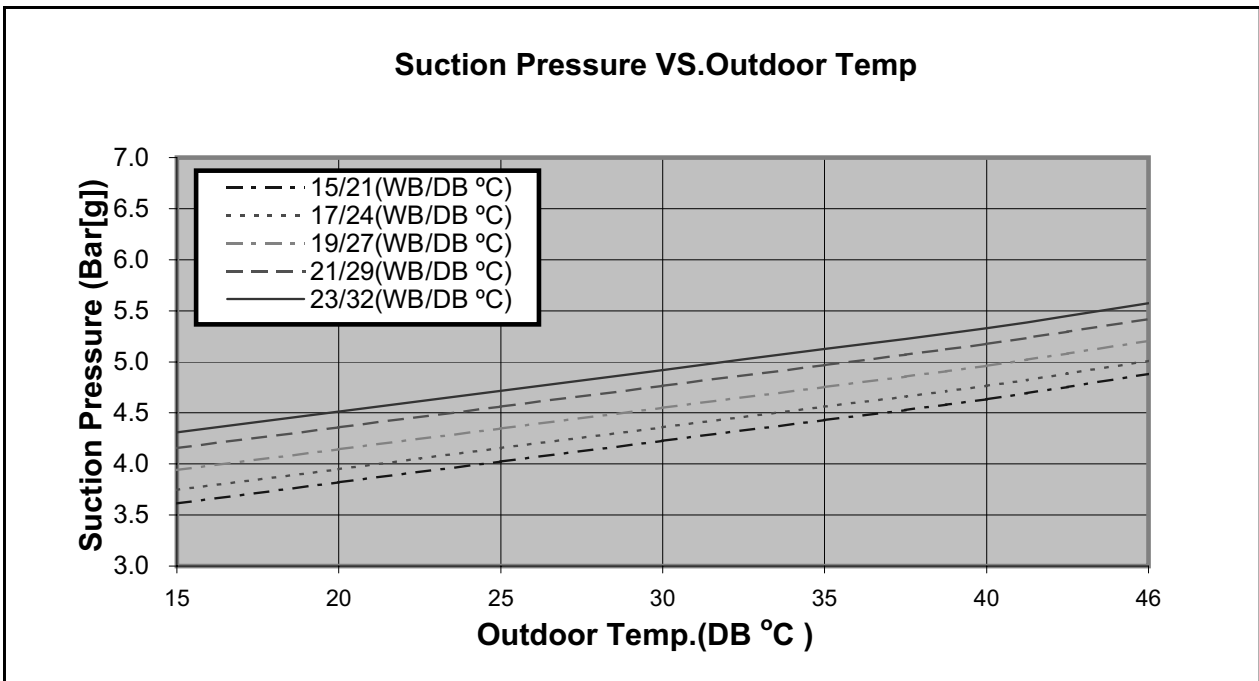
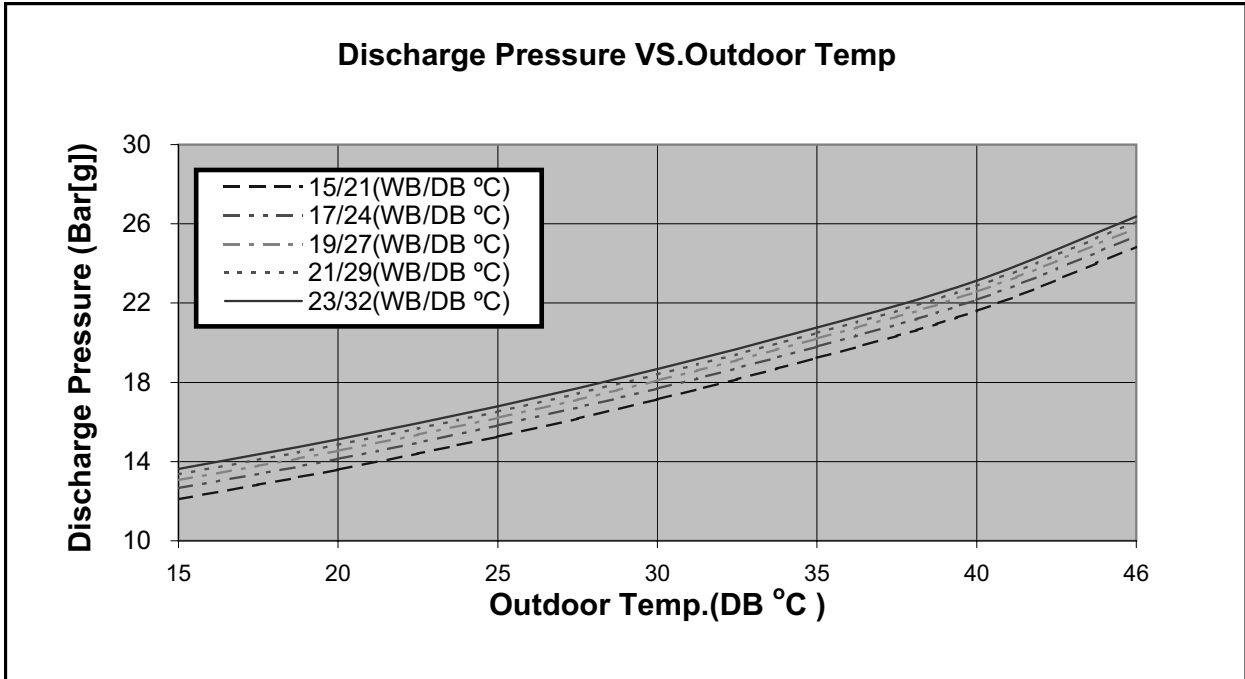

5.4.2 Heating

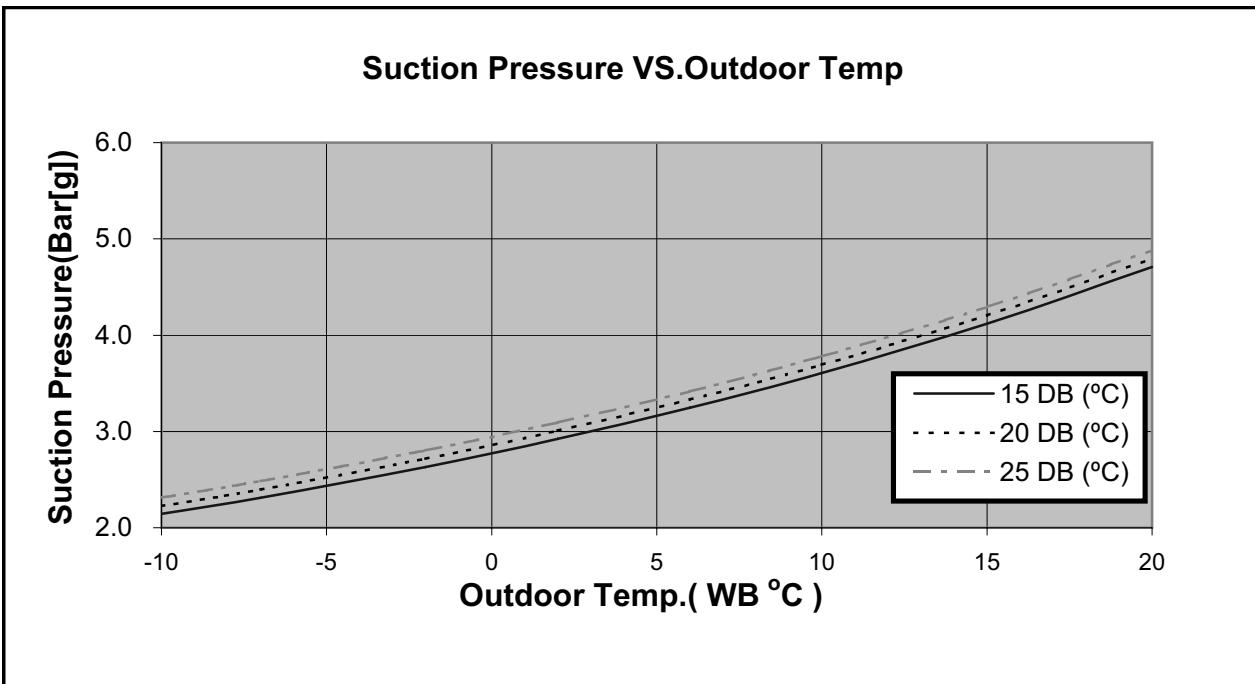
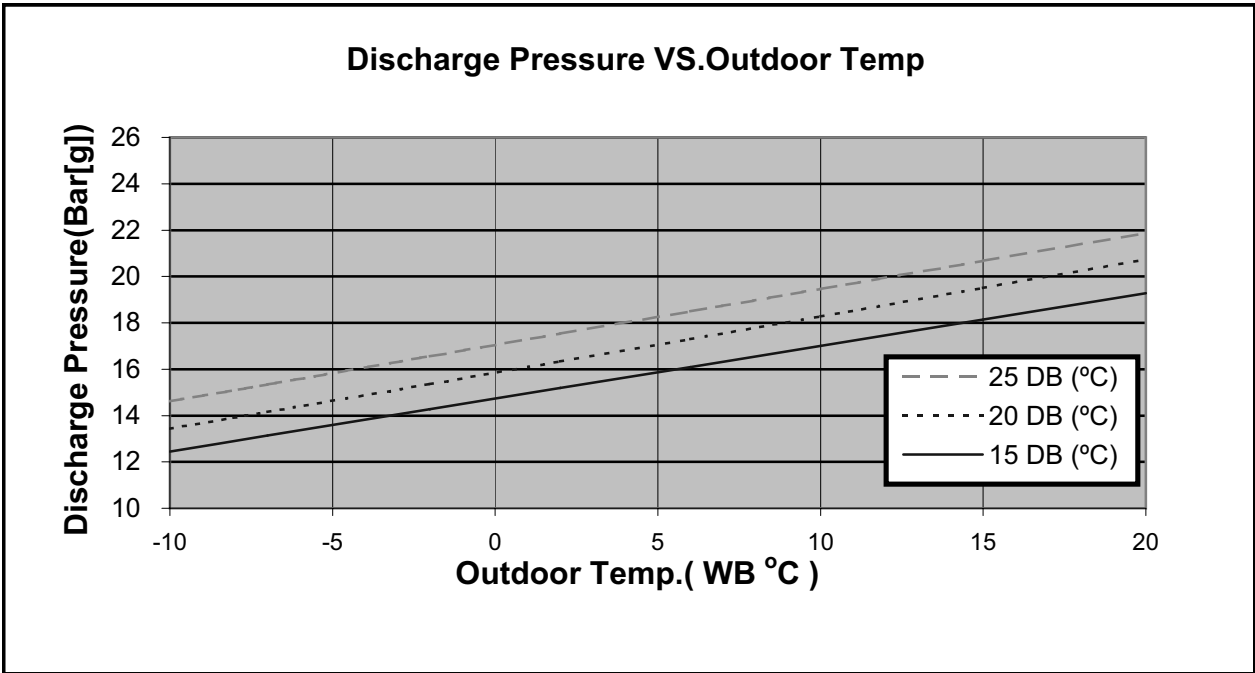

5.5 Alpha9 SP EU/CSP9 EU R410A

5.5.1 Cooling Mode at 7.5m Tubing Connection.

230V : Indoor Fan at High Speed.

Entering Air DB OD Coil(°C)	Data	Entering Air WB/DB ID Coil(°C)				
		15/21	17/24	19/27	21/29	23/32
15	TC	2.69	2.78	2.85	2.92	2.96
	SC	1.87	1.95	2.03	2.08	2.12
	PI	0.63	0.63	0.63	0.63	0.64
20	TC	2.60	2.74	2.83	2.89	2.96
	SC	1.83	1.93	2.01	2.07	2.11
	PI	0.69	0.69	0.69	0.69	0.69
25	TC	2.46	2.66	2.79	2.88	2.95
	SC	1.79	1.90	2.00	2.06	2.09
	PI	0.74	0.75	0.75	0.76	0.76
30	TC	2.30	2.51	2.71	2.80	2.89
	SC	1.73	1.84	1.96	2.01	2.05
	PI	0.80	0.81	0.82	0.82	0.83
35	TC	2.13	2.31	2.55	2.68	2.80
	SC	1.65	1.76	1.91	1.97	2.00
	PI	0.86	0.88	0.89	0.90	0.90
40	TC	1.94	2.11	2.30	2.52	2.65
	SC	1.55	1.67	1.81	1.86	1.90
	PI	0.93	0.94	0.96	0.97	0.98
46	TC	1.68	1.84	2.02	2.23	2.41
	SC	1.43	1.53	1.65	1.70	1.74
	PI	1.02	1.03	1.05	1.07	1.08

LEGEND

- TC – Total Cooling Capacity, kW
- SC – Sensible Capacity, kW
- PI – Power Input, kW
- WB – Wet Bulb Temp., (°C)
- DB – Dry Bulb Temp., (°C)
- ID – Indoor
- OD – Outdoor

(1) Marked area is below standard operating limits. For operating in low ambient conditions, an A.S.K Kit is required

5.5.2 Heating

ENTERING WB OD COIL(°C)	ENTERING AIR DB ID COIL(°C)					
	15		20		25	
	TH	PI	TH	PI	TH	PI
-10	1.39	0.66	1.34	0.70	1.29	0.73
-7	1.50	0.67	1.44	0.71	1.39	0.75
-2	1.59	0.68	1.54	0.72	1.48	0.76
2	1.93	0.71	1.86	0.76	1.78	0.80
6	2.73	0.77	2.65	0.82	2.56	0.87
10	2.97	0.81	2.89	0.87	2.81	0.93
15	3.21	0.84	3.13	0.91	3.05	0.97
20	3.38	0.87	3.30	0.94	3.21	1.02

LEGEND

- TH – Total Heating Capacity, kW
- PI – Power Input, kW
- WB – Wet Bulb Temp., (°C)
- DB – Dry Bulb Temp., (°C)
- ID – Indoor
- OD – Outdoor

5.6 Model: Alpha9 SP EU/CSP9 EU R410A

5.6.1 Cooling

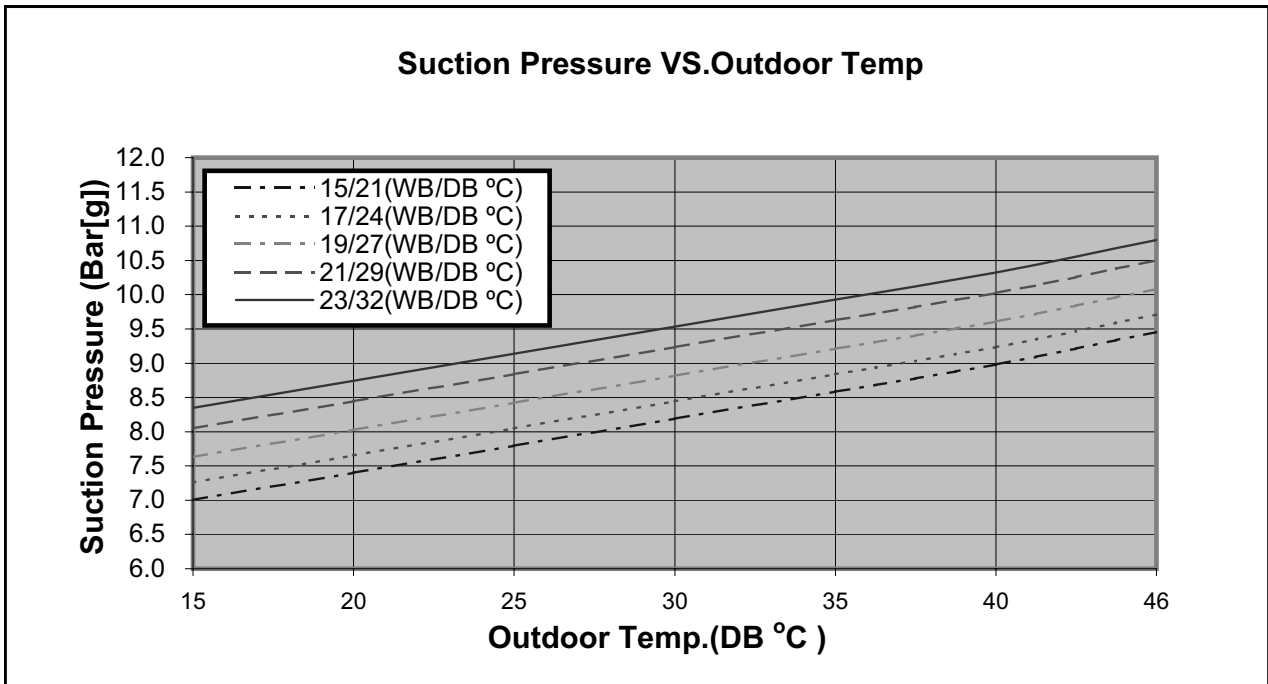
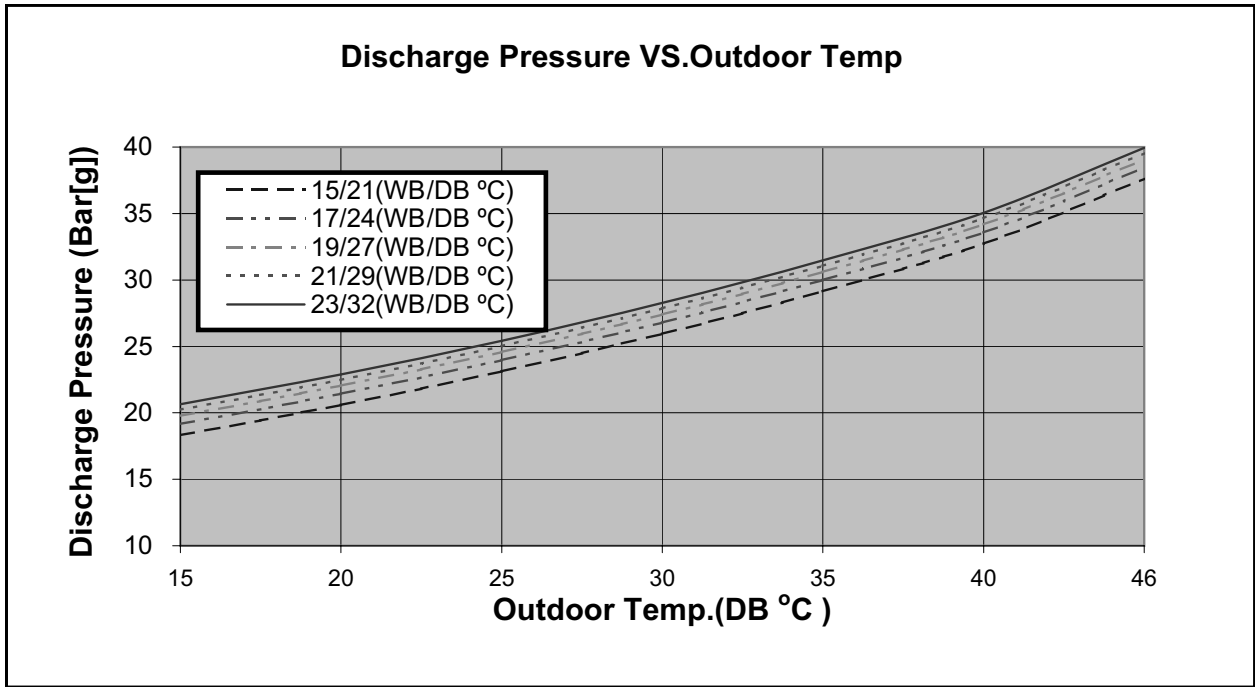

5.6.2 Heating

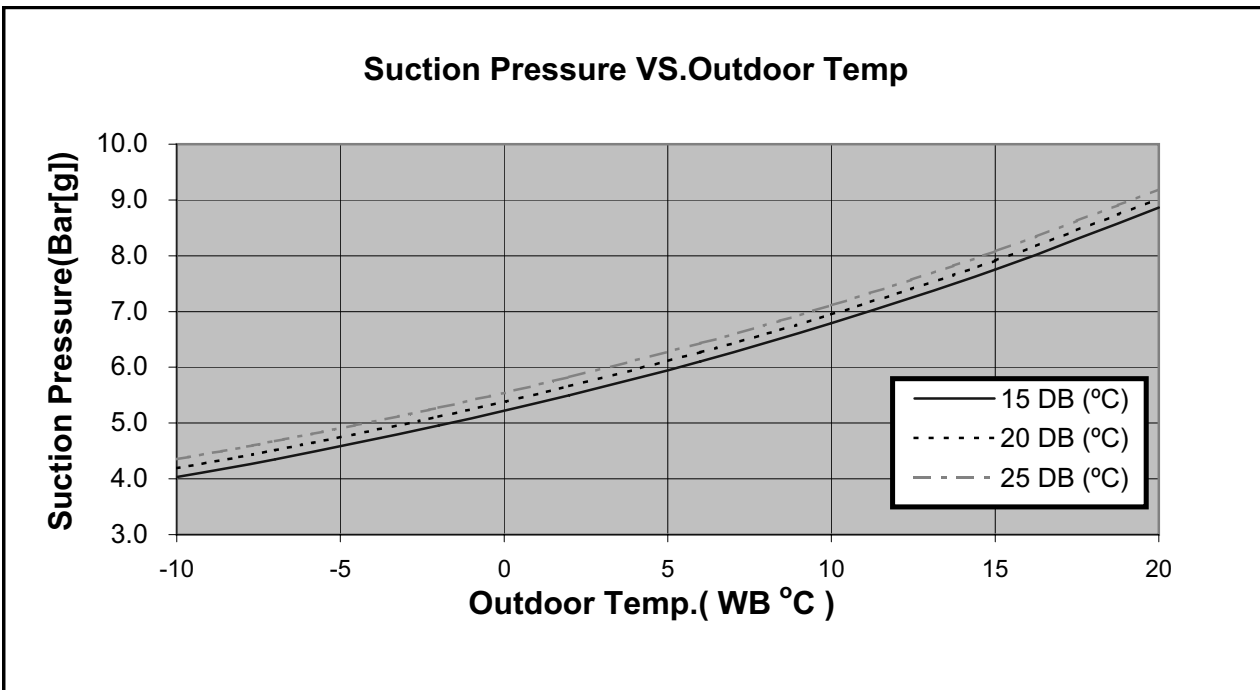
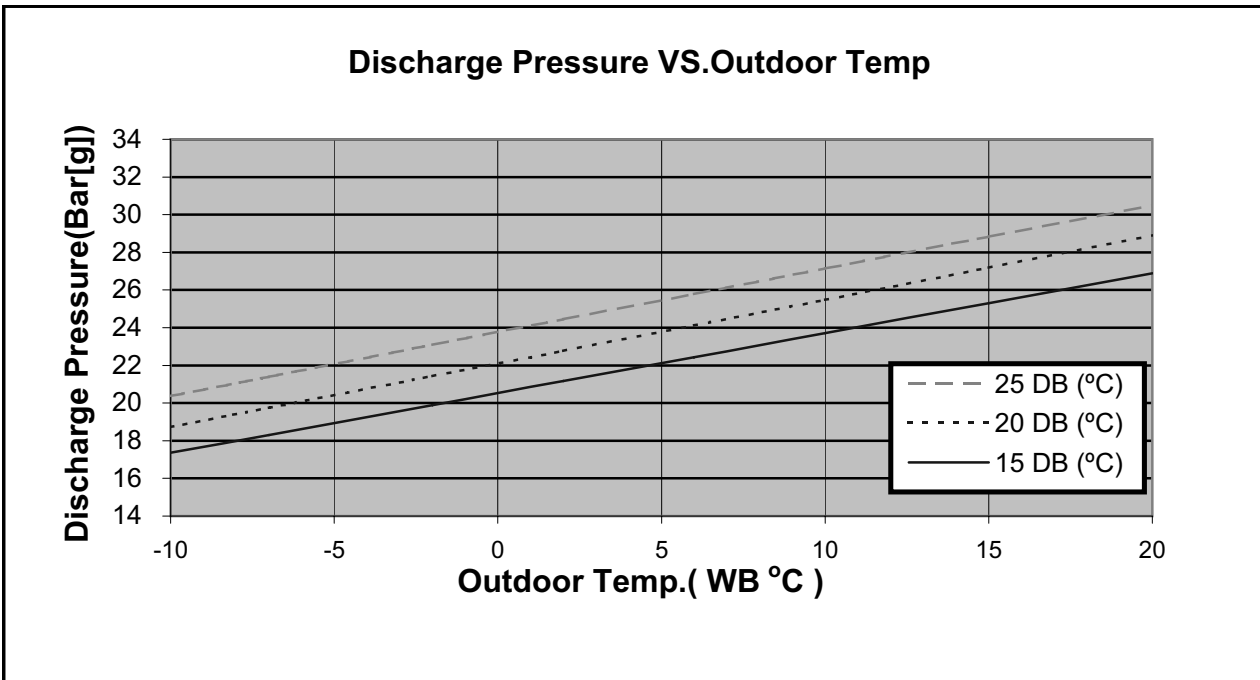

5.7 Model: Alpha12 SP EU/CSP12 EU R410A

5.7.1 Cooling Mode at 7.5m Tubing Connection.

230V : Indoor Fan at High Speed.

Entering Air DB OD Coil(°C)	Data	Entering Air WB/DB ID Coil(°C)				
		15/21	17/24	19/27	21/29	23/32
15	TC	3.48	3.60	3.69	3.77	3.83
	SC	2.53	2.64	2.74	2.81	2.86
	PI	0.82	0.82	0.83	0.83	0.83
20	TC	3.37	3.55	3.66	3.75	3.83
	SC	2.48	2.61	2.72	2.80	2.85
	PI	0.89	0.90	0.90	0.90	0.91
25	TC	3.18	3.44	3.61	3.72	3.81
	SC	2.41	2.56	2.70	2.78	2.83
	PI	0.97	0.97	0.98	0.98	0.99
30	TC	2.98	3.24	3.50	3.63	3.73
	SC	2.34	2.48	2.64	2.72	2.77
	PI	1.04	1.06	1.07	1.07	1.08
35	TC	2.76	2.99	3.30	3.47	3.63
	SC	2.22	2.38	2.58	2.65	2.71
	PI	1.12	1.14	1.16	1.17	1.18
40	TC	2.51	2.73	2.98	3.26	3.42
	SC	2.09	2.25	2.44	2.52	2.57
	PI	1.21	1.23	1.25	1.27	1.28
46	TC	2.18	2.38	2.62	2.89	3.11
	SC	1.93	2.07	2.23	2.30	2.35
	PI	1.32	1.34	1.37	1.39	1.41

LEGEND

- TC – Total Cooling Capacity, kWv
- SC – Sensible Capacity, kW
- PI – Power Input, kW
- WB – Wet Bulb Temp., (°C)
- DB – Dry Bulb Temp., (°C)
- ID – Indoor
- OD – Outdoor

(1) Marked area is below standard operating limits. For operating in low ambient conditions, refer to Optional Accessories (Chapter 15).

5.7.2 Heating

ENTERING WB OD COIL(°C)	ENTERING AIR DB ID COIL(°C)					
	15		20		25	
	TH	PI	TH	PI	TH	PI
-10	1.79	0.84	1.72	0.89	1.65	0.94
-7	1.92	0.86	1.85	0.91	1.79	0.96
-2	2.04	0.87	1.97	0.92	1.90	0.98
2	2.48	0.91	2.38	0.97	2.28	1.03
6	3.50	0.98	3.40	1.05	3.28	1.12
10	3.81	1.04	3.71	1.11	3.60	1.18
15	4.11	1.08	4.01	1.17	3.91	1.24
20	4.34	1.11	4.23	1.21	4.11	1.30

LEGEND

- TH – Total Heating Capacity, kW
- PI – Power Input, kW
- WB – Wet Bulb Temp., (°C)
- DB – Dry Bulb Temp., (°C)
- ID – Indoor
- OU – Outdoor

5.8. Model: Alpha12 SP EU/CSP12 EU R410A

5.8.1 Cooling

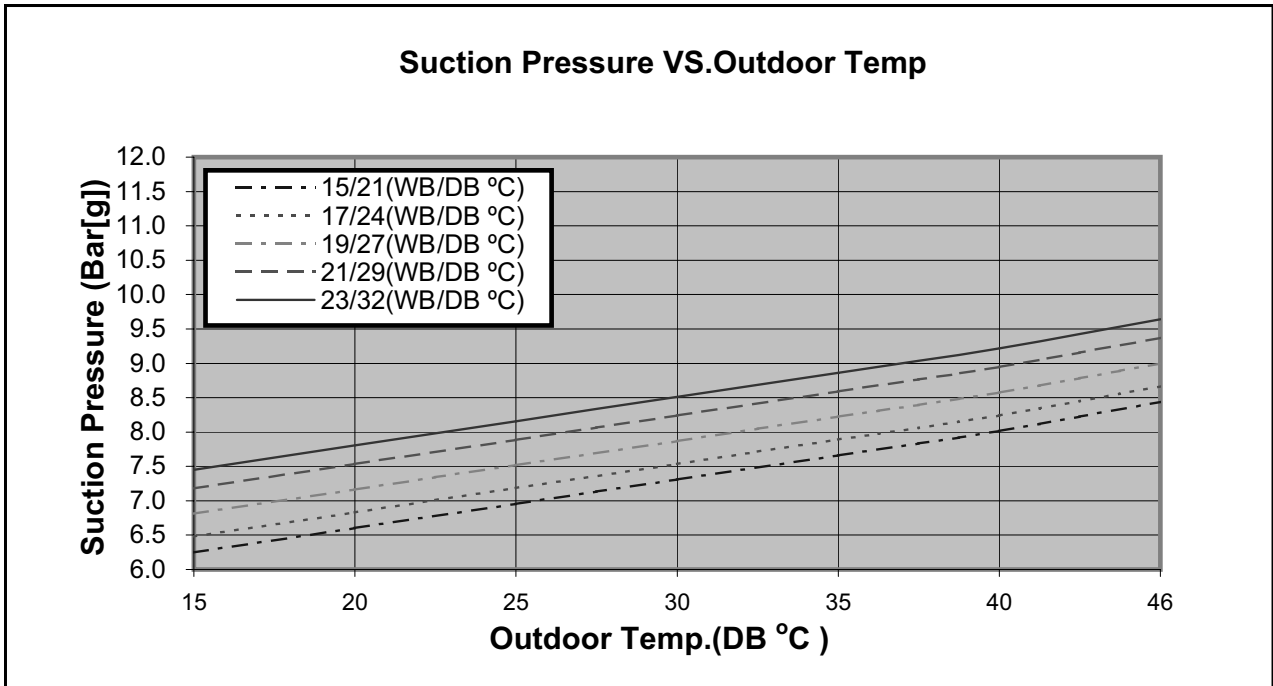
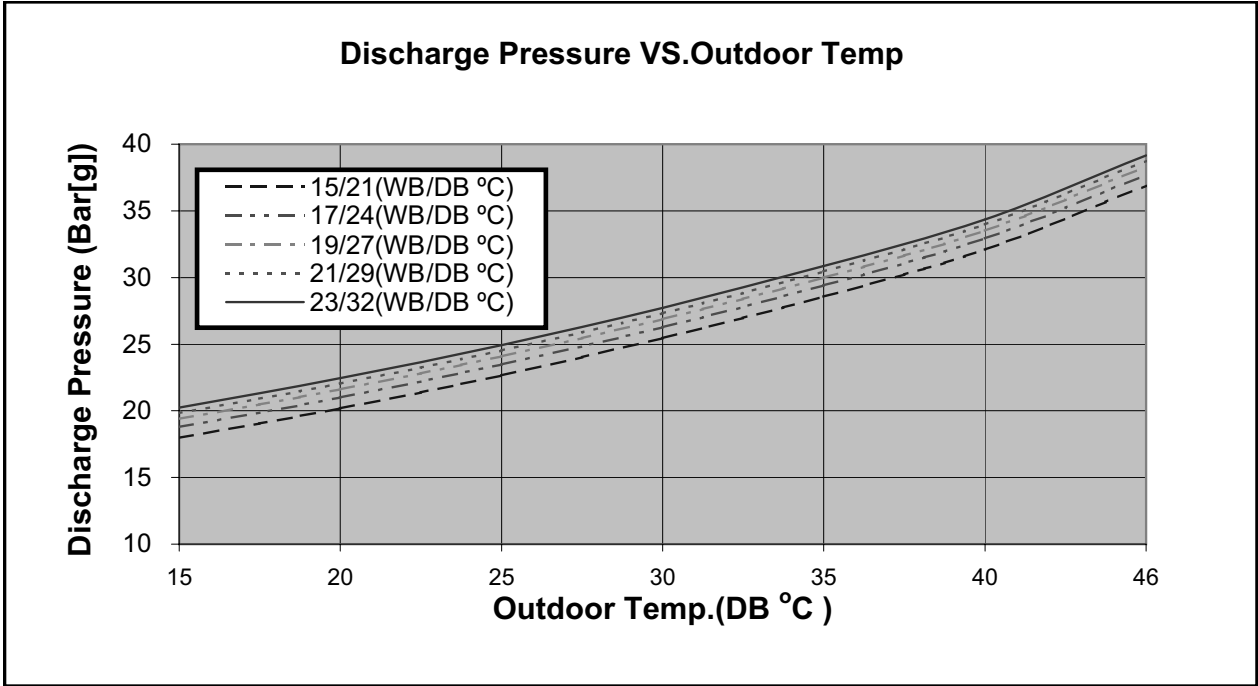

5.8.2 Heating.

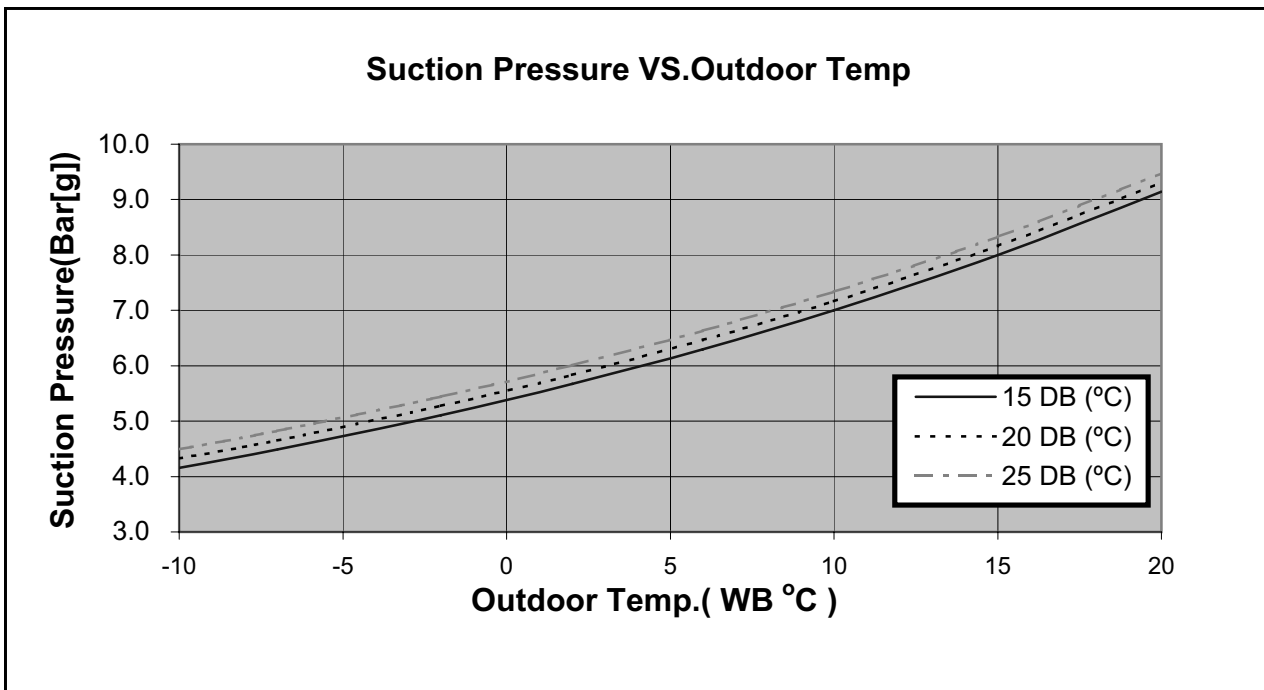
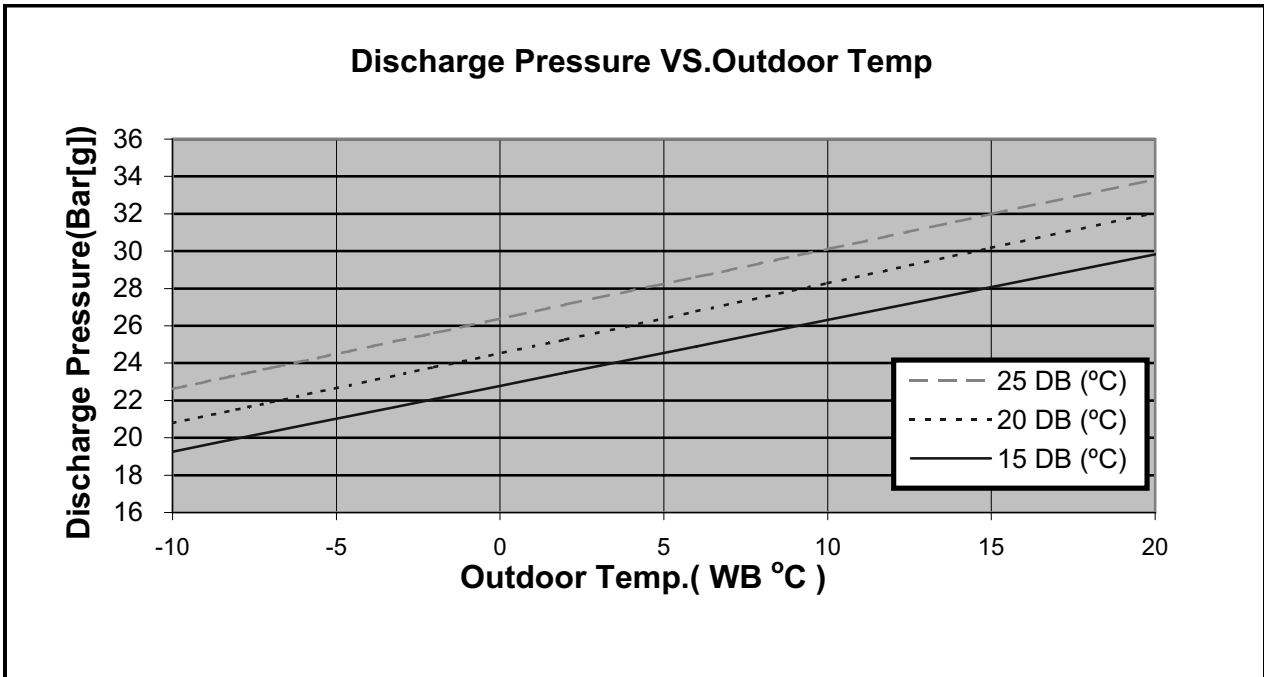

5.9 Model: Alpha9 SP ISR/CSP9 ISR R410A A1

5.9.1 Cooling Mode at 7.5m Tubing Connection.

230V : Indoor Fan at High Speed.

Entering Air DB OD Coil(°C)	Data	Entering Air WB/DB ID Coil(°C)				
		15/21	17/24	19/27	21/29	23/32
15	TC	2.74	2.84	2.91	2.97	3.02
	SC	1.99	2.07	2.15	2.21	2.25
	PI	0.57	0.58	0.58	0.58	0.58
20	TC	2.65	2.79	2.88	2.95	3.01
	SC	1.95	2.05	2.14	2.20	2.24
	PI	0.62	0.63	0.63	0.63	0.63
25	TC	2.51	2.71	2.85	2.93	3.01
	SC	1.90	2.01	2.12	2.19	2.23
	PI	0.67	0.68	0.68	0.69	0.69
30	TC	2.35	2.55	2.76	2.86	2.94
	SC	1.84	1.95	2.08	2.14	2.18
	PI	0.73	0.74	0.74	0.75	0.76
35	TC	2.17	2.36	2.60	2.73	2.86
	SC	1.75	1.87	2.03	2.09	2.13
	PI	0.78	0.80	0.81	0.82	0.82
40	TC	1.98	2.15	2.35	2.57	2.70
	SC	1.65	1.77	1.92	1.98	2.02
	PI	0.85	0.86	0.87	0.88	0.89
46	TC	1.71	1.87	2.06	2.28	2.45
	SC	1.52	1.63	1.75	1.81	1.85
	PI	0.92	0.94	0.96	0.97	0.98

LEGEND

- TC – Total Cooling Capacity, kWv
- SC – Sensible Capacity, kW
- PI – Power Input, kW
- WB – Wet Bulb Temp., (°C)
- DB – Dry Bulb Temp., (°C)
- ID – Indoor
- OD – Outdoor

(1) Marked area is below standard operating limits. For operating in low ambient conditions, refer to Optional Accessories (Chapter 15).

5.9.2 Heating

ENTERING WB OD COIL(°C)	ENTERING AIR DB ID COIL(°C)					
	15		20		25	
	TH	PI	TH	PI	TH	PI
-10	1.47	0.64	1.41	0.68	1.36	0.72
-7	1.58	0.66	1.53	0.69	1.47	0.73
-2	1.68	0.66	1.62	0.70	1.57	0.74
2	2.04	0.70	1.96	0.74	1.88	0.78
6	2.88	0.75	2.80	0.80	2.70	0.85
10	3.14	0.79	3.05	0.84	2.97	0.90
15	3.39	0.82	3.30	0.89	3.22	0.94
20	3.57	0.85	3.49	0.92	3.39	0.99

LEGEND

- TH – Total Heating Capacity, kW
- PI – Power Input, kW
- WB – Wet Bulb Temp., (°C)
- DB – Dry Bulb Temp., (°C)
- ID – Indoor
- OU – Outdoor

5.10. Model: Alpha9 SP ISR/CSP9 ISR R410A A1

5.10.1 Cooling

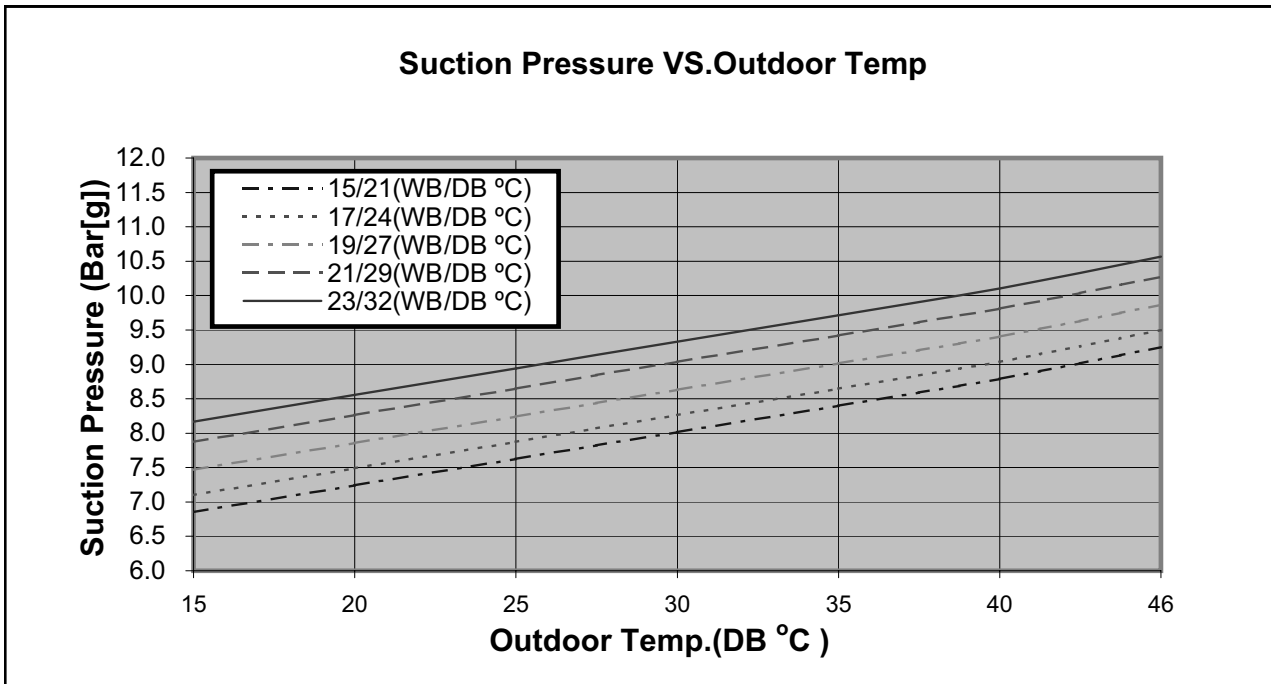
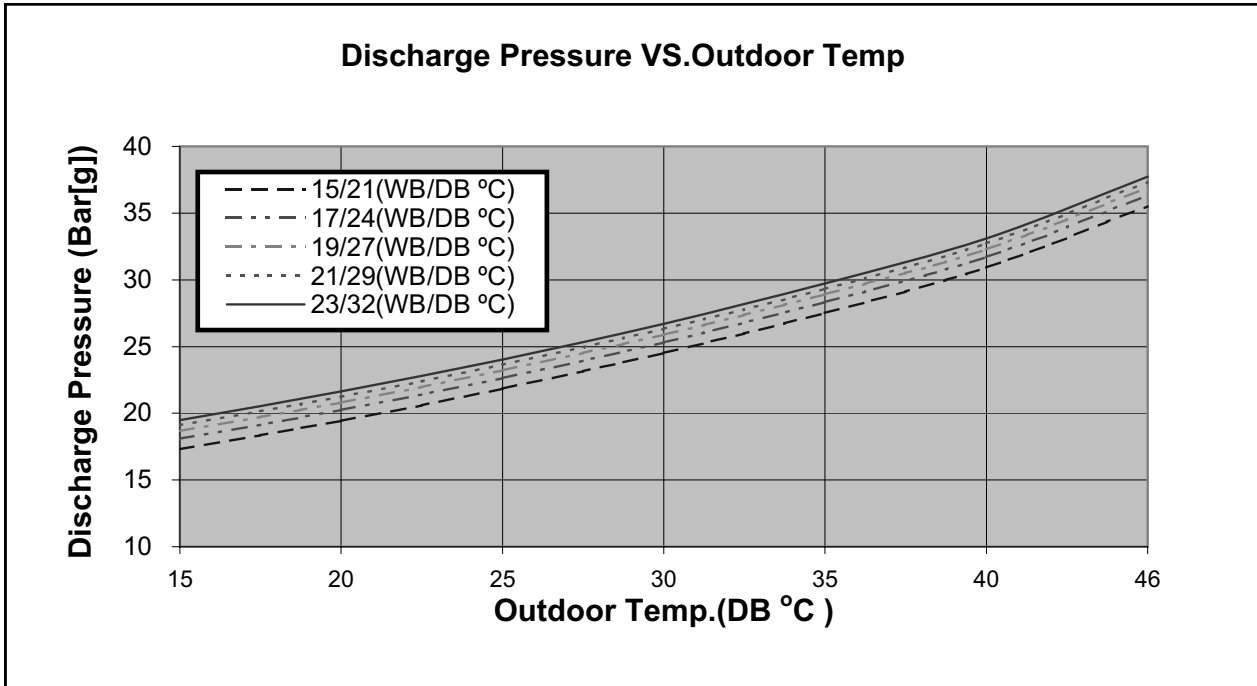

5.10.2 Heating.

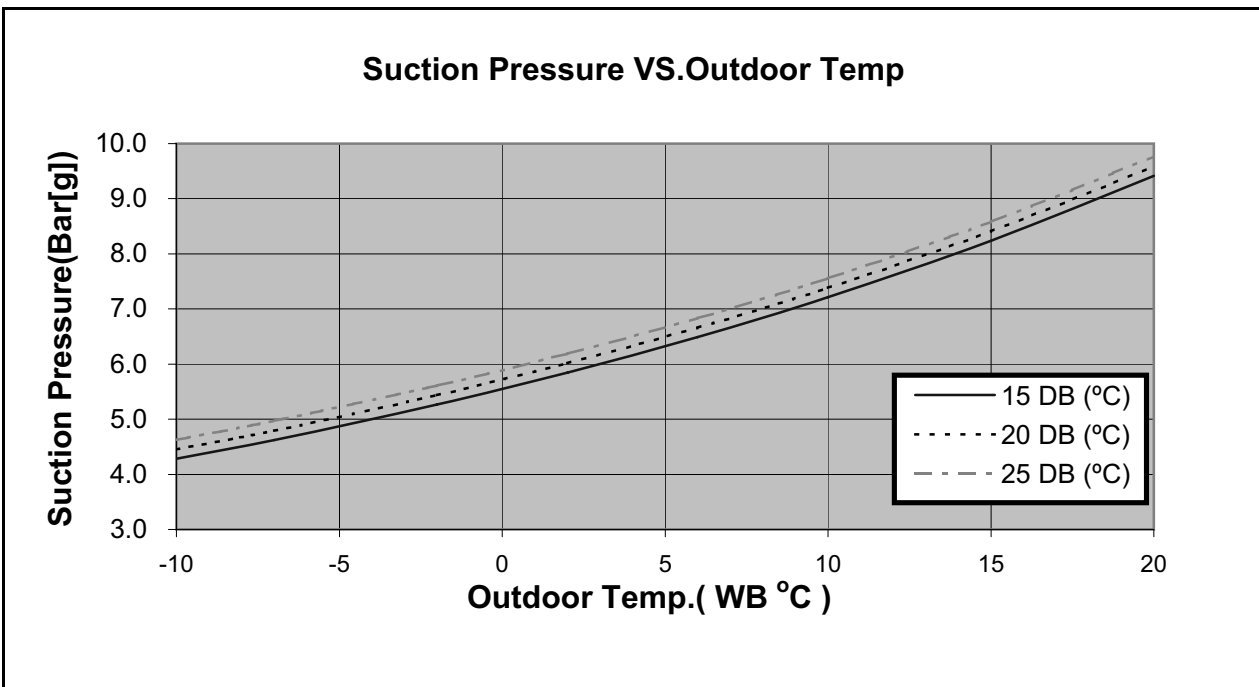
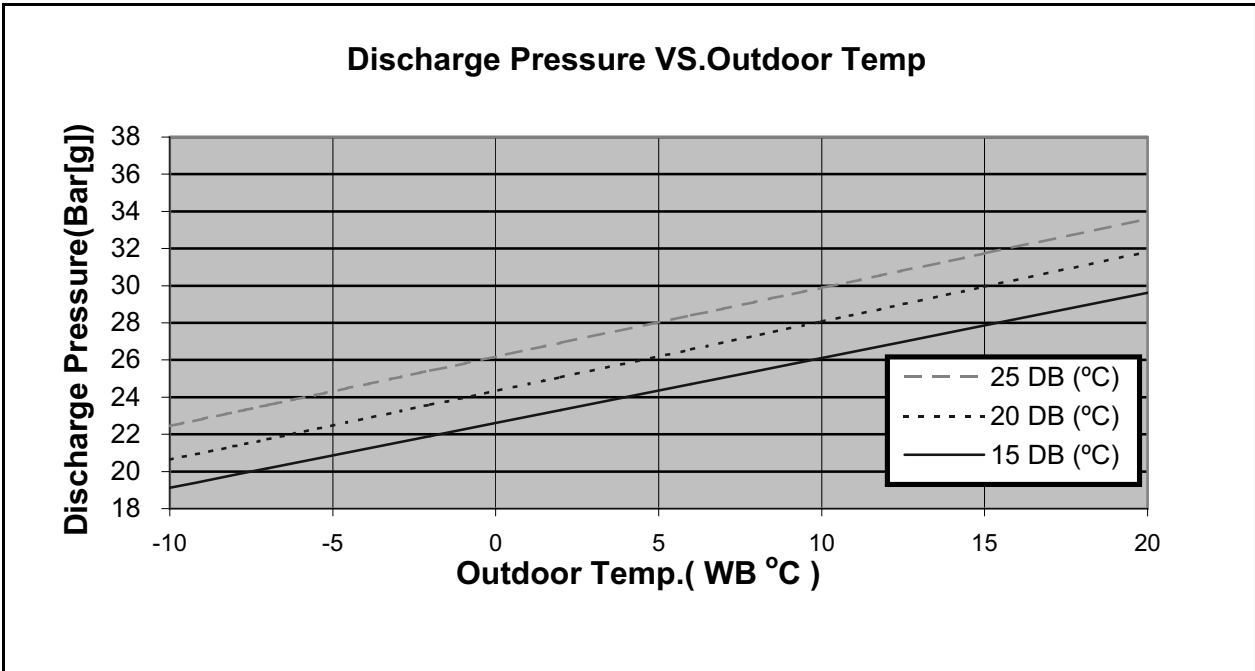

5.11 Model: Alpha12 SP ISR/CSP12 ISR R410A A1

5.11.1 Cooling Mode at 7.5m Tubing Connection.

230V : Indoor Fan at High Speed.

Entering Air DB OD Coil(°C)	Data	Entering Air WB/DB ID Coil(°C)				
		15/21	17/24	19/27	21/29	23/32
15	TC	3.58	3.71	3.80	3.89	3.95
	SC	2.50	2.60	2.71	2.77	2.82
	PI	0.79	0.79	0.79	0.79	0.80
20	TC	3.47	3.65	3.77	3.86	3.94
	SC	2.45	2.58	2.69	2.77	2.82
	PI	0.85	0.86	0.86	0.86	0.87
25	TC	3.28	3.54	3.72	3.84	3.93
	SC	2.39	2.53	2.67	2.75	2.80
	PI	0.92	0.93	0.94	0.94	0.95
30	TC	3.07	3.34	3.61	3.74	3.85
	SC	2.31	2.46	2.61	2.69	2.74
	PI	1.00	1.01	1.02	1.03	1.04
35	TC	2.84	3.08	3.40	3.57	3.74
	SC	2.20	2.35	2.55	2.62	2.68
	PI	1.07	1.09	1.11	1.12	1.12
40	TC	2.58	2.81	3.07	3.35	3.53
	SC	2.07	2.23	2.41	2.49	2.54
	PI	1.16	1.18	1.20	1.21	1.22
46	TC	2.24	2.45	2.69	2.98	3.21
	SC	1.91	2.04	2.20	2.28	2.33
	PI	1.27	1.29	1.31	1.33	1.35

LEGEND

- TC – Total Cooling Capacity, kWv
- SC – Sensible Capacity, kW
- PI – Power Input, kW
- WB – Wet Bulb Temp., (°C)
- DB – Dry Bulb Temp., (°C)
- ID – Indoor
- OD – Outdoor

(1) Marked area is below standard operating limits. For operating in low ambient conditions, refer to Optional Accessories (Chapter 15).

5.11.2 Heating

ENTERING WB OD COIL(°C)	ENTERING AIR DB ID COIL(°C)					
	15		20		25	
	TH	PI	TH	PI	TH	PI
-10	1.89	0.93	1.82	0.99	1.75	1.04
-7	2.03	0.95	1.96	1.00	1.89	1.06
-2	2.16	0.96	2.09	1.02	2.02	1.08
2	2.63	1.01	2.52	1.07	2.41	1.14
6	3.71	1.08	3.60	1.16	3.47	1.23
10	4.03	1.14	3.92	1.22	3.82	1.31
15	4.36	1.19	4.25	1.29	4.14	1.37
20	4.59	1.23	4.48	1.33	4.36	1.44

LEGEND

- TH – Total Heating Capacity, kW
- PI – Power Input, kW
- WB – Wet Bulb Temp., (°C)
- DB – Dry Bulb Temp., (°C)
- ID – Indoor
- OU – Outdoor

5.12. Model: Alpha12 SP ISR/CSP12 ISR R410A A1

5.12.1 Cooling

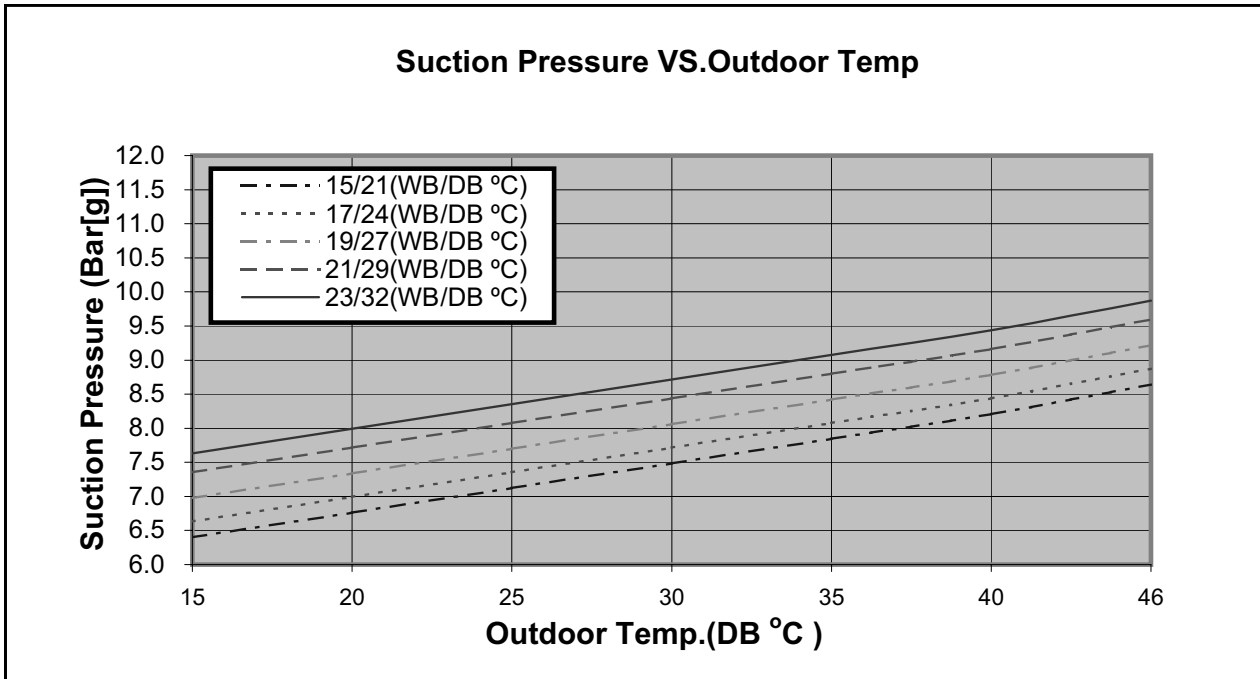
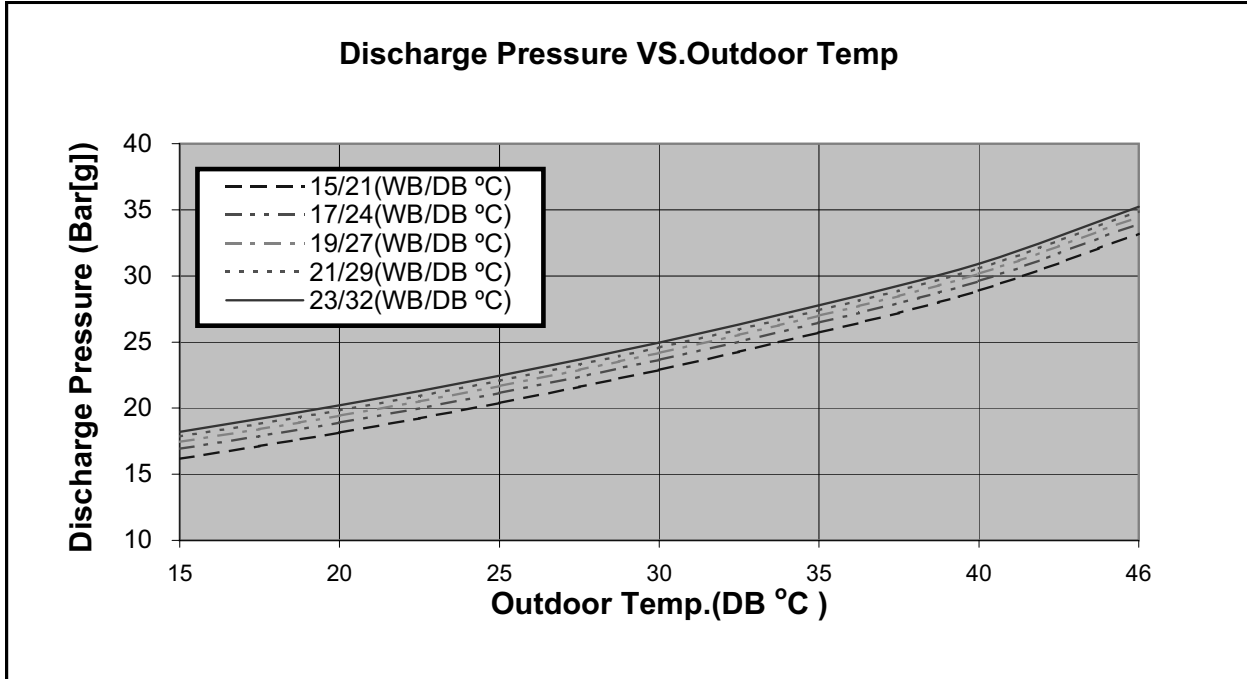

5.12.2 Heating.

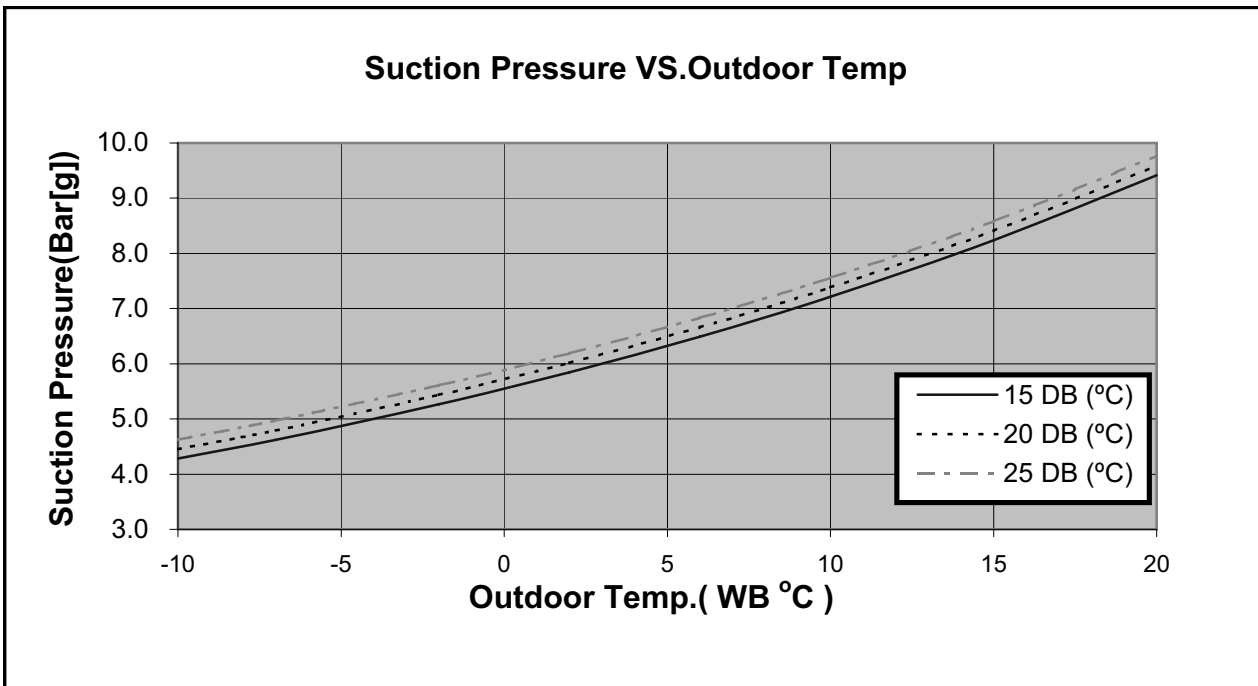
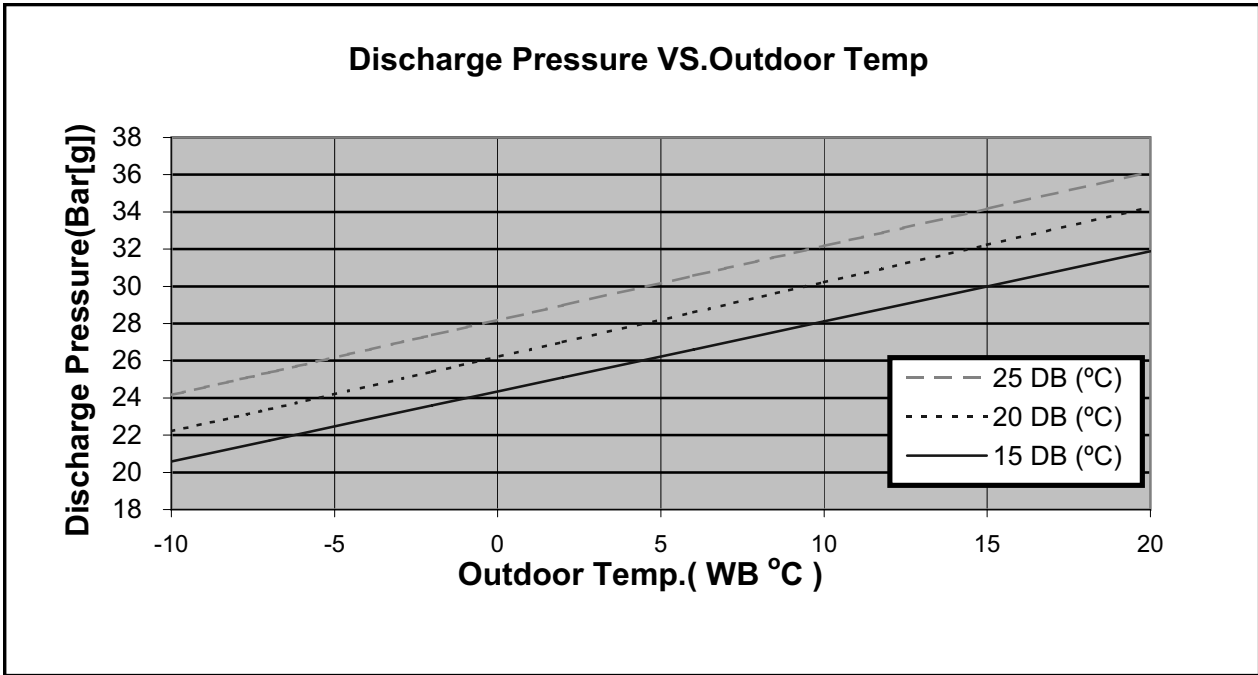

5.13 Model: Alpha SP 9 R410A A2 ISR / CSP 9 R410A A2 ISR

5.13.1 Cooling Mode at 7.5m Tubing Connection.

230V : Indoor Fan at High Speed.

Entering Air DB OD Coil(°C)	Data	Entering Air WB/DB ID Coil(°C)				
		15/21	17/24	19/27	21/29	23/32
15	TC	2.90	3.00	3.07	3.15	3.19
	SC	2.10	2.19	2.27	2.33	2.37
	PI	0.57	0.57	0.57	0.57	0.57
20	TC	2.80	2.96	3.05	3.12	3.19
	SC	2.05	2.17	2.26	2.32	2.36
	PI	0.62	0.62	0.62	0.62	0.62
25	TC	2.65	2.86	3.01	3.10	3.18
	SC	2.00	2.12	2.24	2.30	2.35
	PI	0.67	0.67	0.67	0.68	0.68
30	TC	2.48	2.70	2.92	3.02	3.11
	SC	1.94	2.06	2.19	2.25	2.30
	PI	0.72	0.73	0.73	0.74	0.75
35	TC	2.30	2.49	2.75	2.89	3.02
	SC	1.84	1.98	2.14	2.20	2.24
	PI	0.77	0.79	0.80	0.81	0.81
40	TC	2.09	2.27	2.48	2.71	2.85
	SC	1.74	1.87	2.02	2.09	2.13
	PI	0.84	0.85	0.86	0.87	0.88
46	TC	1.81	1.98	2.18	2.41	2.59
	SC	1.60	1.71	1.85	1.91	1.95
	PI	0.91	0.93	0.95	0.96	0.97

LEGEND

- TC – Total Cooling Capacity, kWv
- SC – Sensible Capacity, kW
- PI – Power Input, kW
- WB – Wet Bulb Temp., (°C)
- DB – Dry Bulb Temp., (°C)
- ID – Indoor
- OD – Outdoor

(1) Marked area is below standard operating limits. For operating in low ambient conditions, refer to Optional Accessories (Chapter 15).

5.13.2 Heating

ENTERING WB OD COIL(°C)	ENTERING AIR DB ID COIL(°C)					
	15		20		25	
	TH	PI	TH	PI	TH	PI
-10	1.39	0.64	1.34	0.68	1.29	0.72
-7	1.50	0.66	1.44	0.69	1.39	0.73
-2	1.59	0.66	1.54	0.70	1.48	0.74
2	1.93	0.70	1.86	0.74	1.78	0.78
6	2.73	0.75	2.65	0.80	2.56	0.85
10	2.97	0.79	2.89	0.84	2.81	0.90
15	3.21	0.82	3.13	0.89	3.05	0.94
20	3.38	0.85	3.30	0.92	3.21	0.99

LEGEND

- TH – Total Heating Capacity, kW
- PI – Power Input, kW
- WB – Wet Bulb Temp., (°C)
- DB – Dry Bulb Temp., (°C)
- ID – Indoor
- OU – Outdoor

5.14. Model: Alpha 9 SP ISR / CSP 9 ISR R410A A2

5.14.1 Cooling

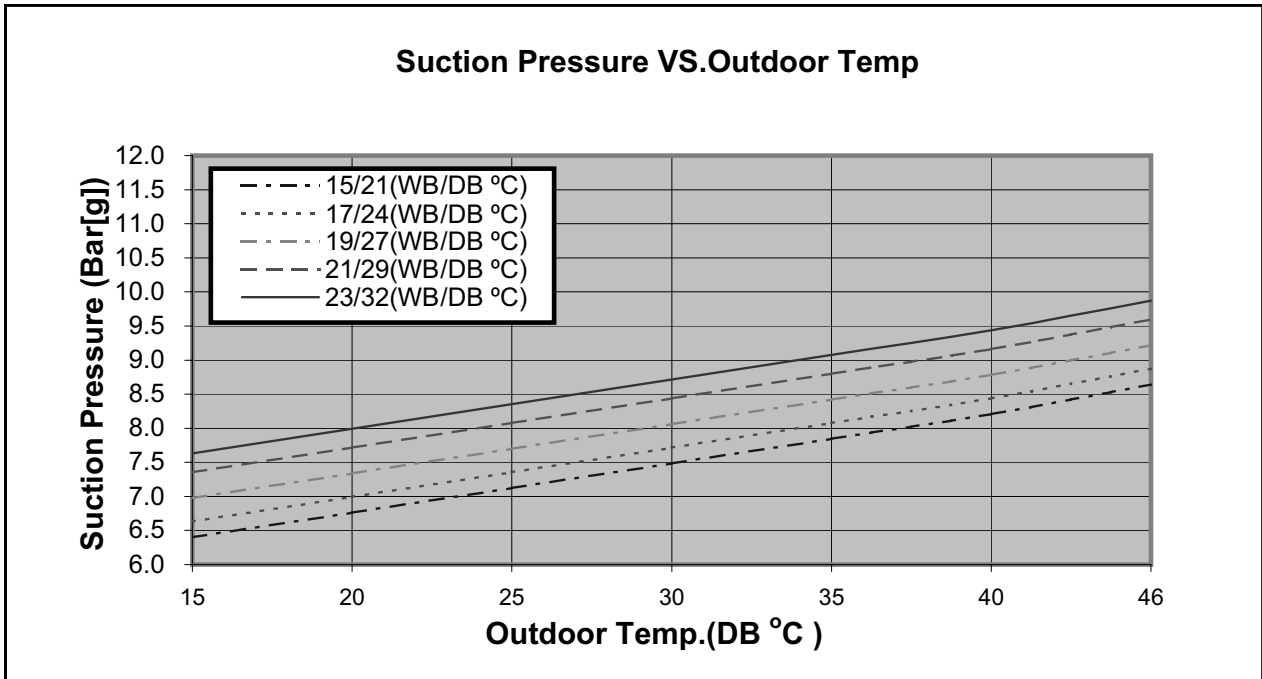
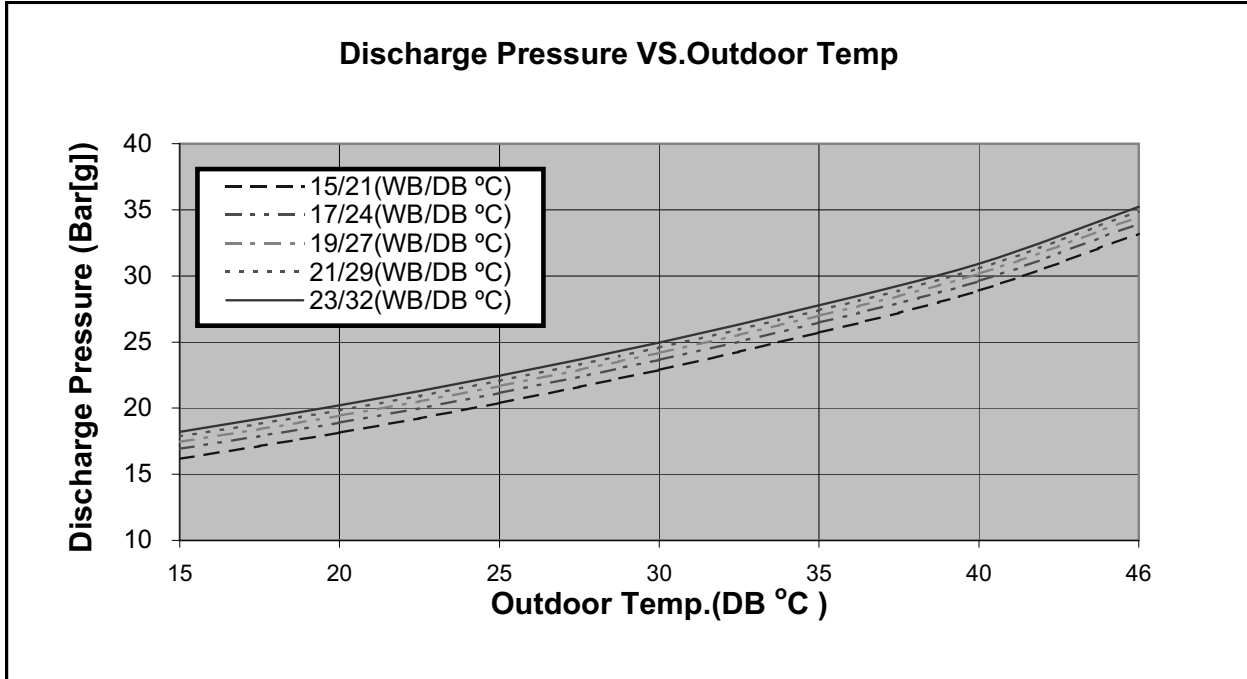

5.8.2 Heating.

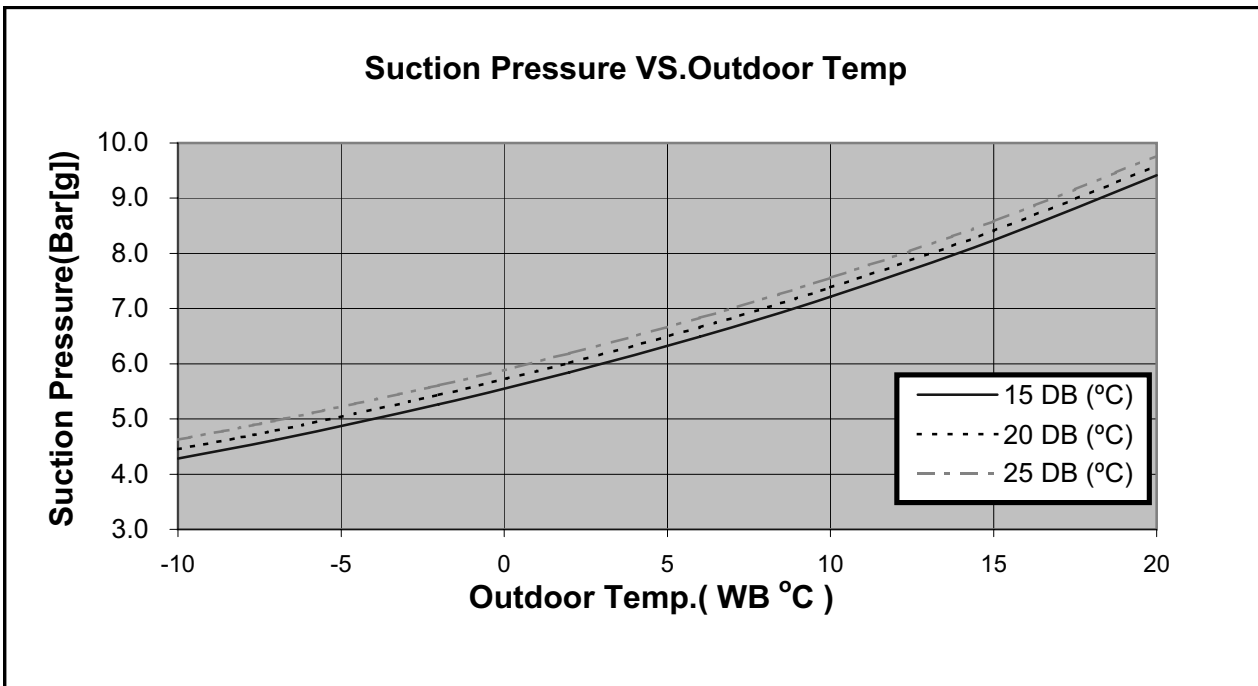
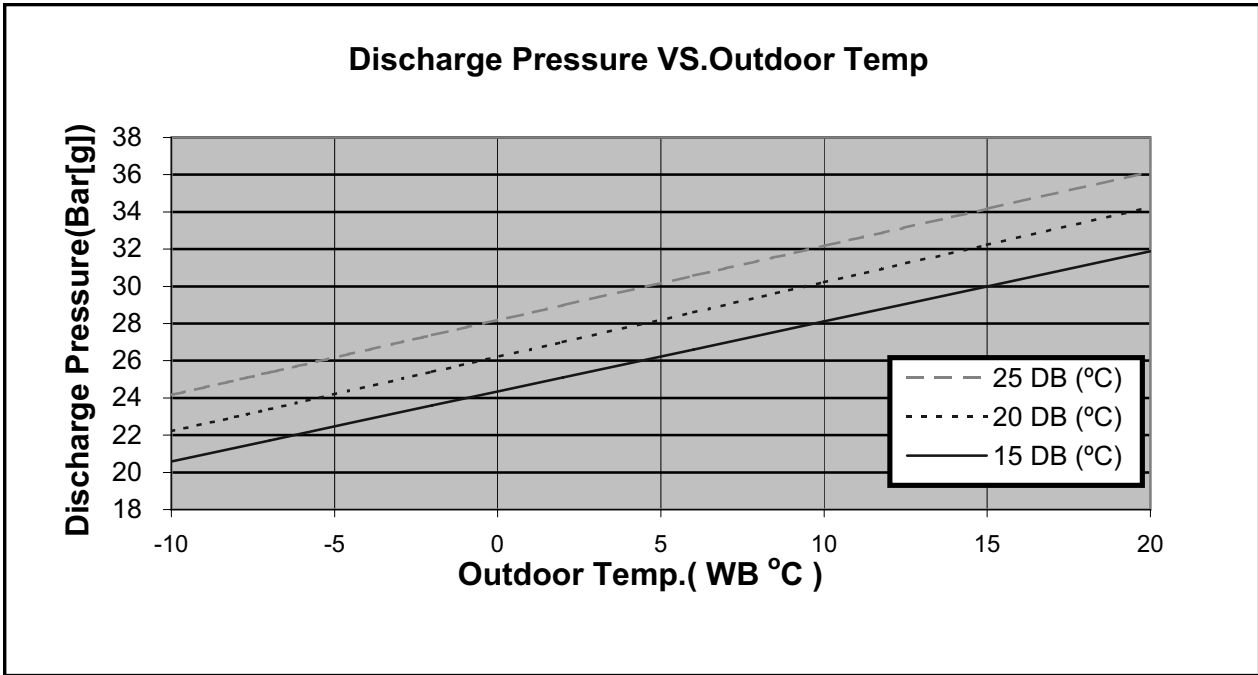

5.15 Model: Alpha SP 12 R410A A2 ISR / CSP 12 R410A A2 ISR

5.15.1 Cooling Mode at 7.5m Tubing Connection.

230V : Indoor Fan at High Speed.

Entering Air DB OD Coil(°C)	Data	Entering Air WB/DB ID Coil(°C)				
		15/21	17/24	19/27	21/29	23/32
15	TC	3.70	3.83	3.92	4.02	4.08
	SC	2.68	2.80	2.91	2.98	3.03
	PI	0.74	0.74	0.74	0.74	0.75
20	TC	3.58	3.77	3.89	3.98	4.07
	SC	2.63	2.77	2.89	2.97	3.03
	PI	0.80	0.80	0.81	0.81	0.81
25	TC	3.39	3.66	3.84	3.96	4.06
	SC	2.56	2.72	2.87	2.95	3.00
	PI	0.87	0.87	0.88	0.88	0.89
30	TC	3.17	3.45	3.73	3.86	3.97
	SC	2.48	2.64	2.80	2.89	2.94
	PI	0.93	0.95	0.96	0.96	0.97
35	TC	2.93	3.18	3.51	3.69	3.86
	SC	2.36	2.53	2.74	2.82	2.87
	PI	1.01	1.02	1.04	1.05	1.05
40	TC	2.67	2.90	3.17	3.46	3.64
	SC	2.22	2.39	2.59	2.67	2.73
	PI	1.09	1.10	1.12	1.14	1.15
46	TC	2.31	2.53	2.78	3.07	3.31
	SC	2.05	2.20	2.36	2.45	2.50
	PI	1.19	1.20	1.23	1.25	1.26

LEGEND

- TC – Total Cooling Capacity, kWv
- SC – Sensible Capacity, kW
- PI – Power Input, kW
- WB – Wet Bulb Temp., (°C)
- DB – Dry Bulb Temp., (°C)
- ID – Indoor
- OD – Outdoor

(1) Marked area is below standard operating limits. For operating in low ambient conditions, refer to Optional Accessories (Chapter 15).

5.15.2 Heating

ENTERING WB OD COIL(°C)	ENTERING AIR DB ID COIL(°C)					
	15		20		25	
	TH	PI	TH	PI	TH	PI
-10	1.84	0.80	1.77	0.85	1.70	0.90
-7	1.98	0.82	1.91	0.87	1.84	0.91
-2	2.11	0.83	2.04	0.88	1.97	0.93
2	2.56	0.87	2.46	0.93	2.35	0.98
6	3.62	0.94	3.51	1.00	3.39	1.06
10	3.93	0.99	3.83	1.06	3.72	1.13
15	4.25	1.03	4.14	1.11	4.04	1.18
20	4.48	1.06	4.37	1.15	4.25	1.24

LEGEND

- TH – Total Heating Capacity, kW
- PI – Power Input, kW
- WB – Wet Bulb Temp., (°C)
- DB – Dry Bulb Temp., (°C)
- ID – Indoor
- OU – Outdoor

5.16. Model: Alpha 12 SP ISR / CSP 12 ISR R410A A2

5.16.1 Cooling

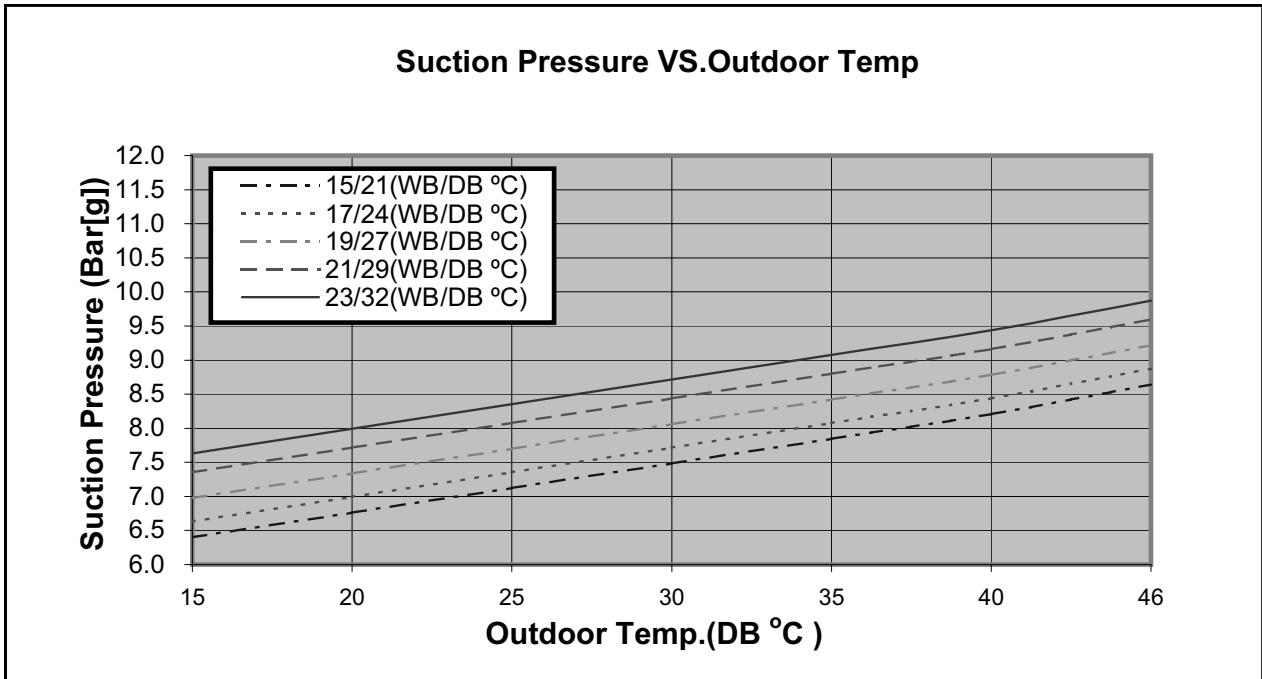
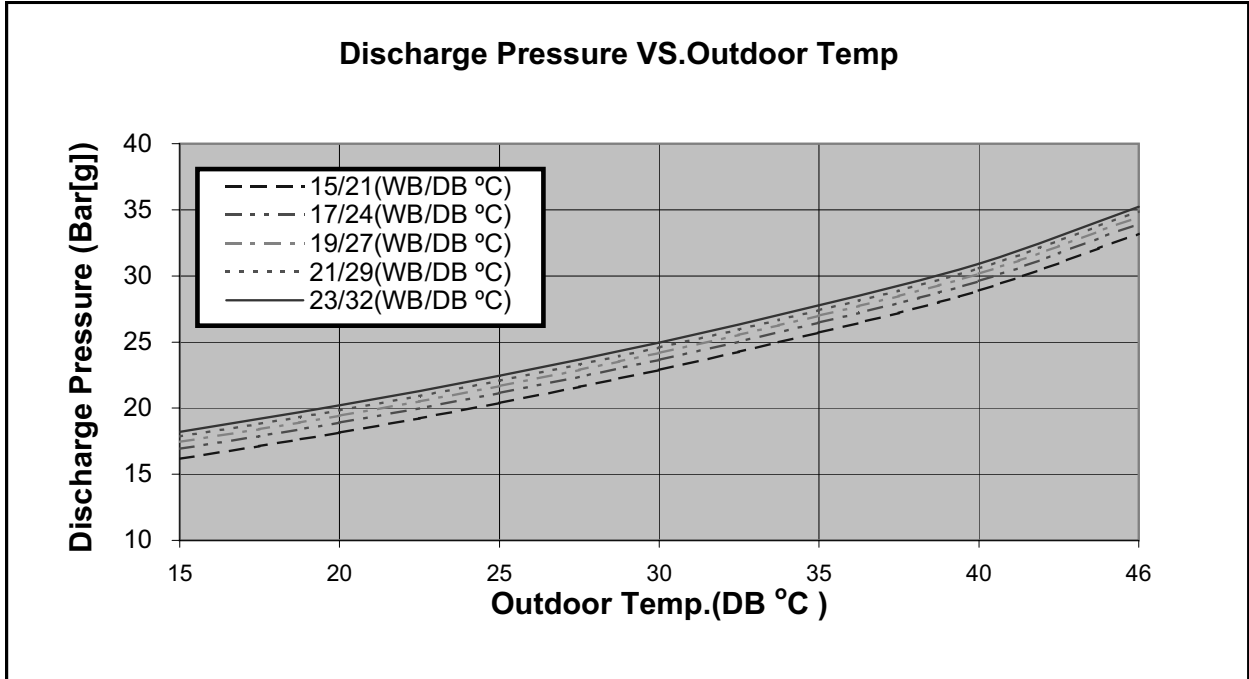

5.16.2 Heating.

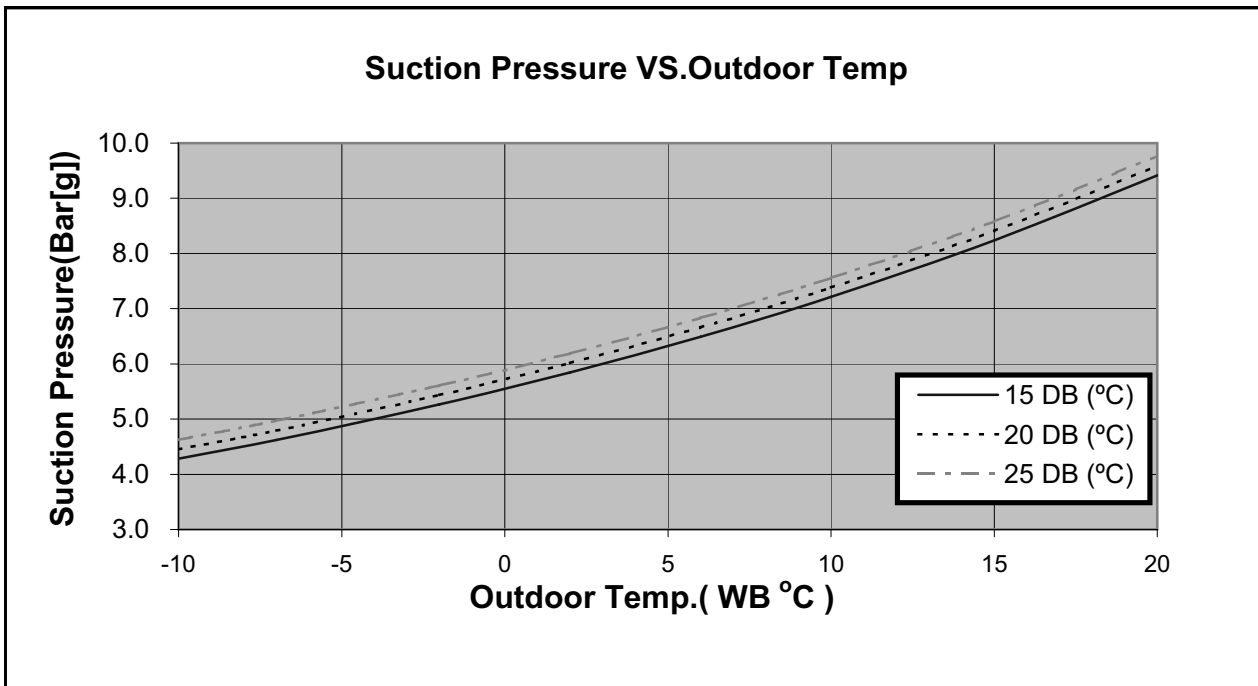
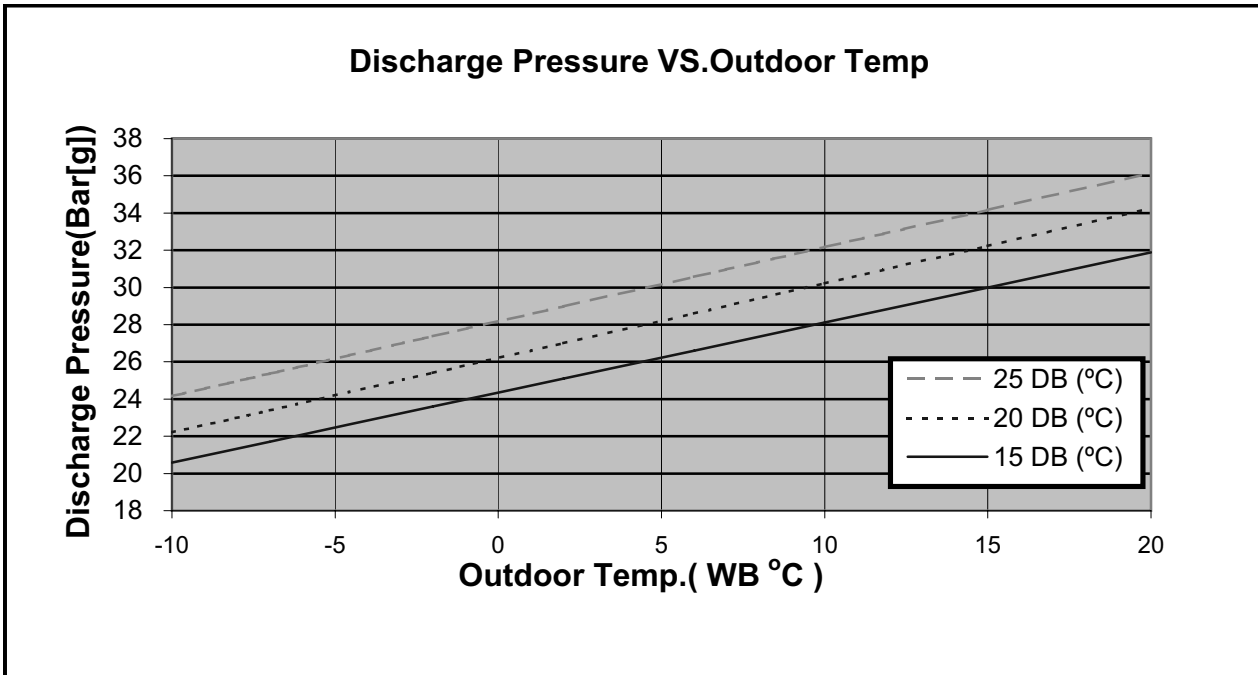

6. SOUND LEVEL CHARACTERISTICS

6.1 Sound Pressure Level

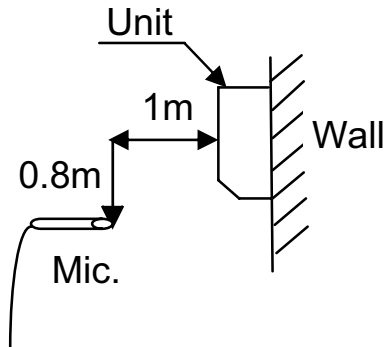
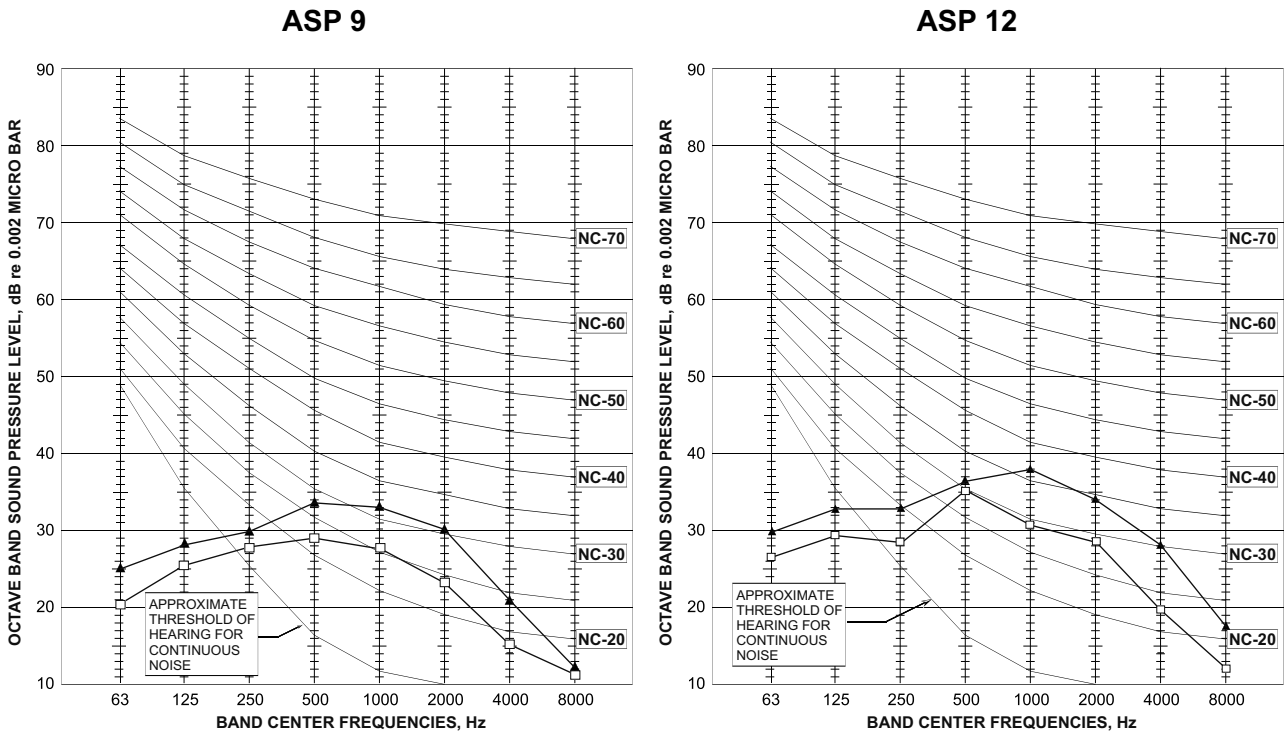

Figure 1

6.2 Sound Pressure Level Spectrum (Measured as Figure 1)



FAN SPEED	LINE
HI	—▲—
ME	—○—
LO	—□—

6.3 Outdoor units

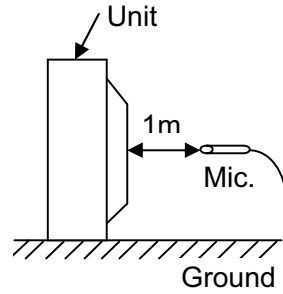
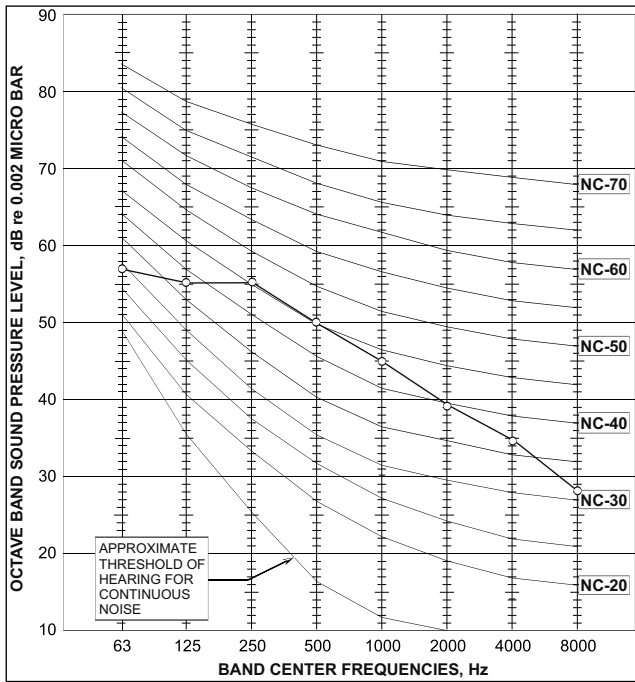

Figure 2

6.4 Sound Pressure Level Spectrum (Measured as Figure 2)

CSP9 RC R22 Cooling



CSP9 RC R22 Heating

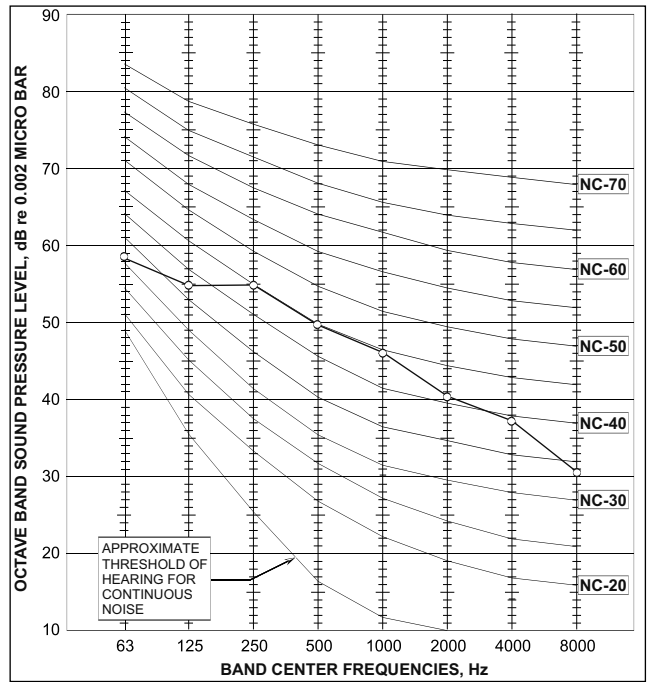

CSP12 RC R22 Cooling

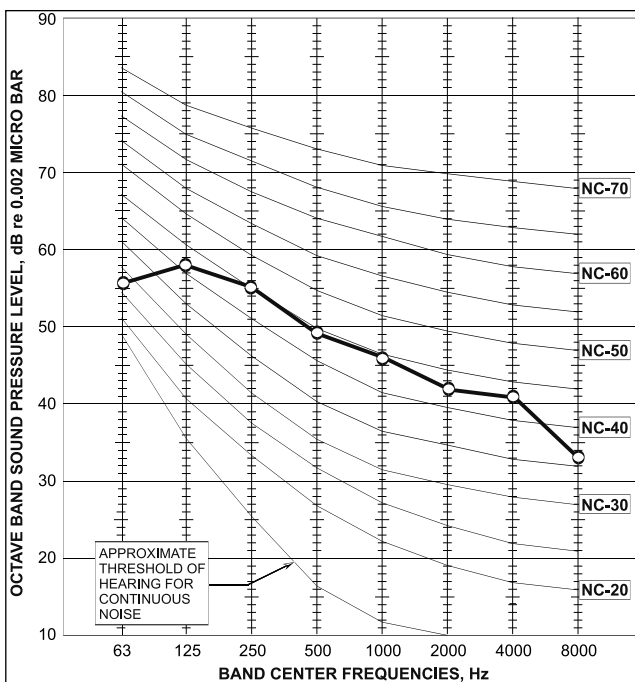

CSP12 RC R22 Heating

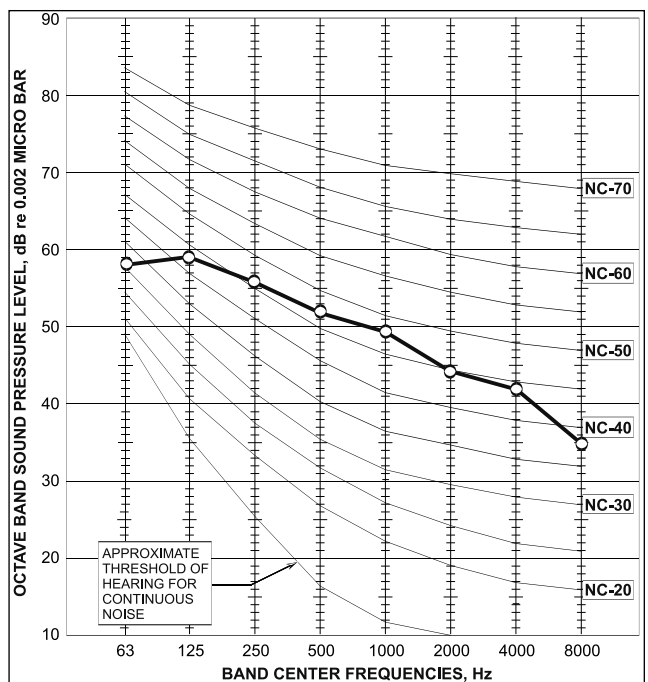

CSP12 ST R22 Cooling

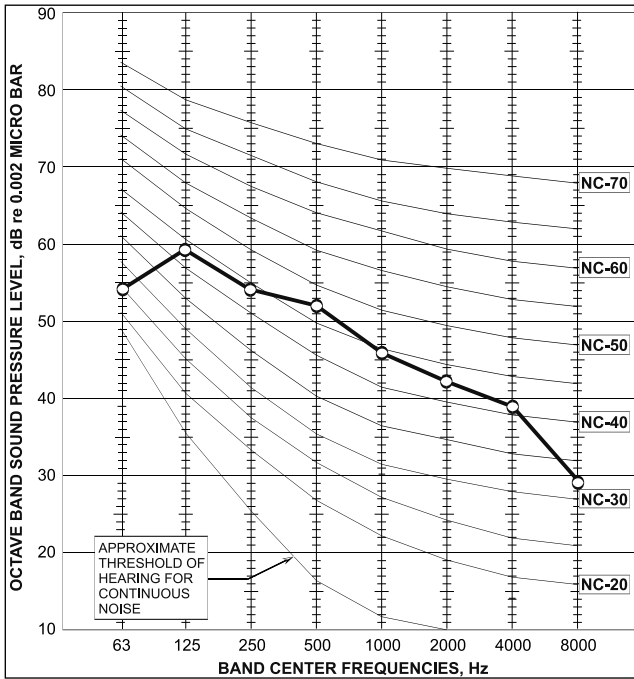

CSP9 RC R410A Cooling

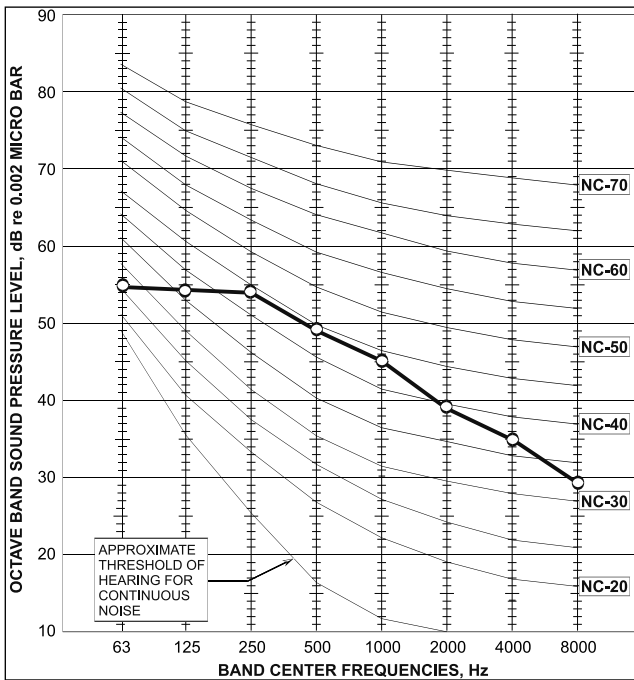

CSP9 RC R410A Heating

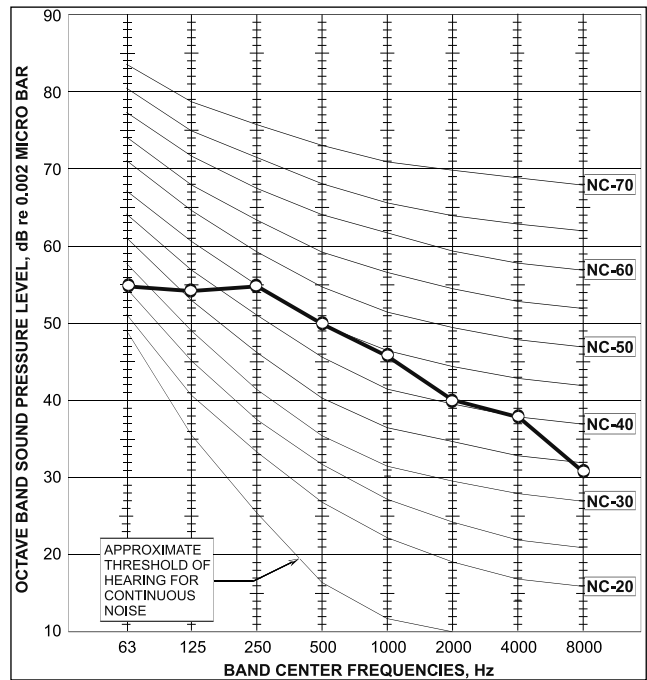

FAN SPEED	LINE
HI	—▲—
ME	—○—
LO	—□—

CSP9 ST R410A Cooling

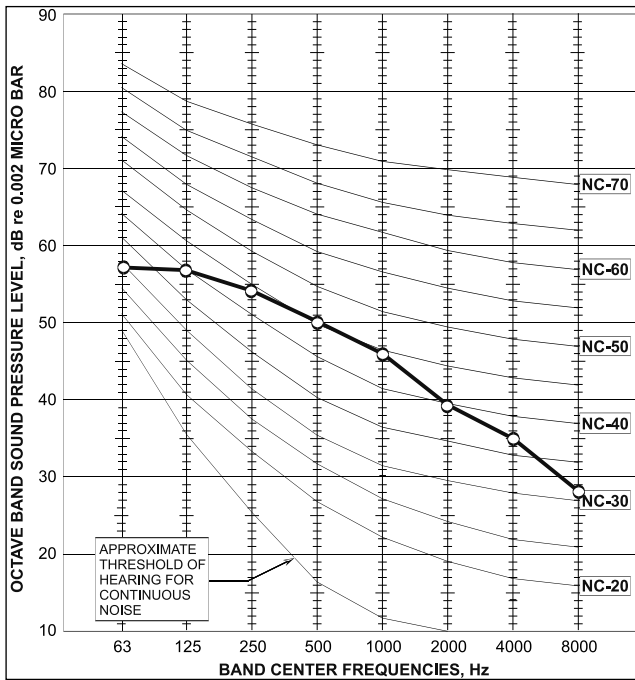

CSP12 RC R410A Cooling

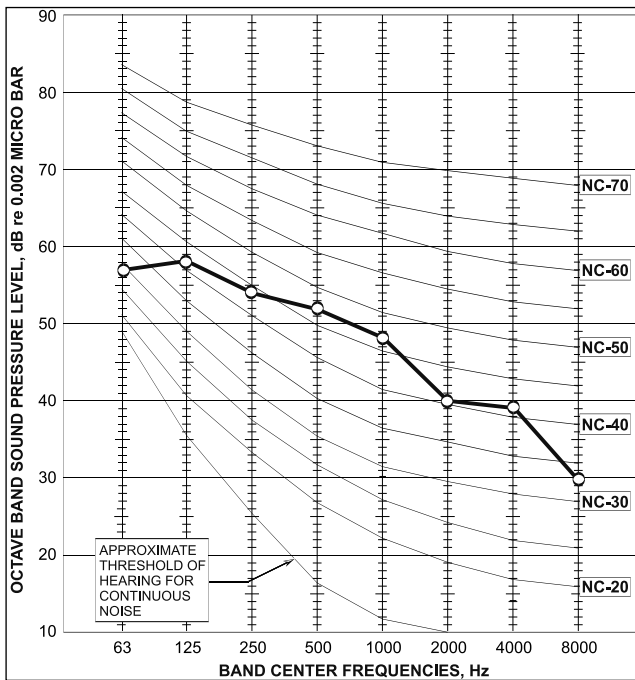

CSP12 RC R410A Heating

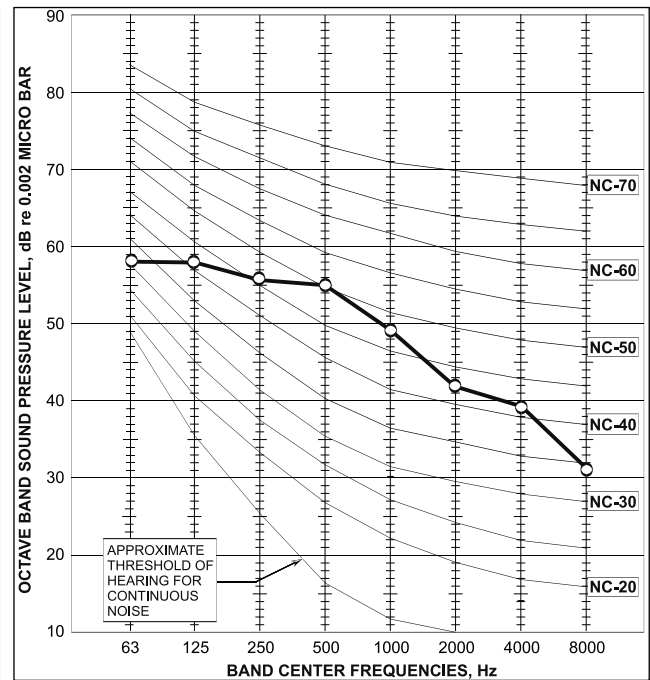

CSP12 ST R410A Cooling

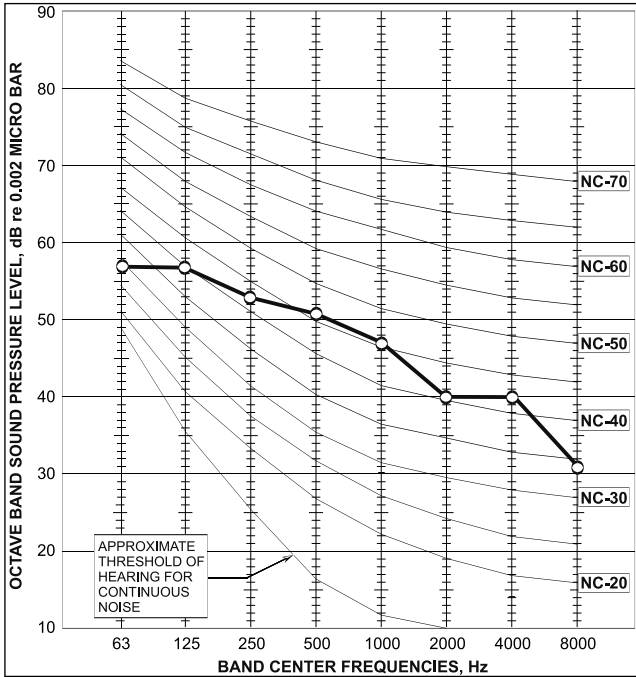

CSP(I)9 RC R410A Cooling

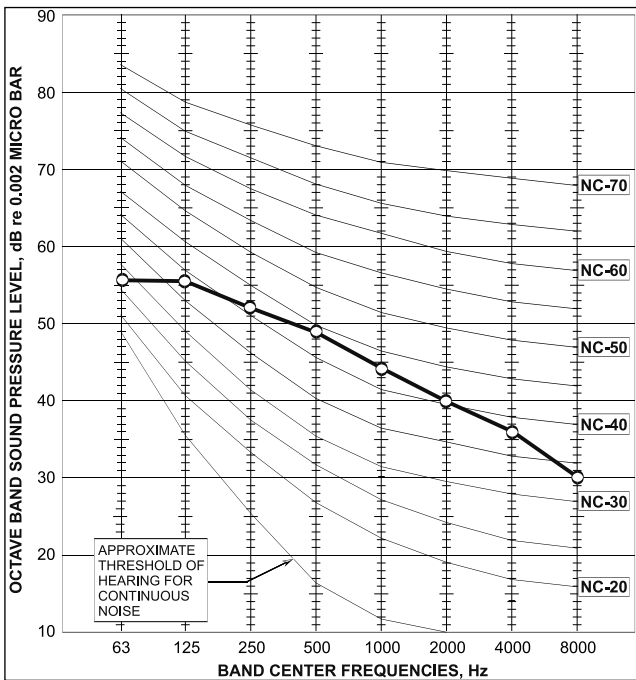

CSP(I)9 RC R410A Heating

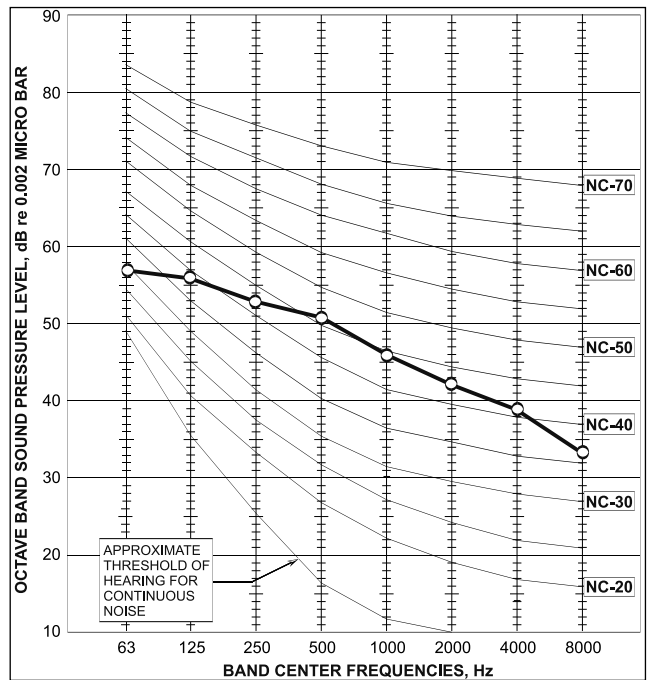

CSP(I)12 RC R410A Cooling

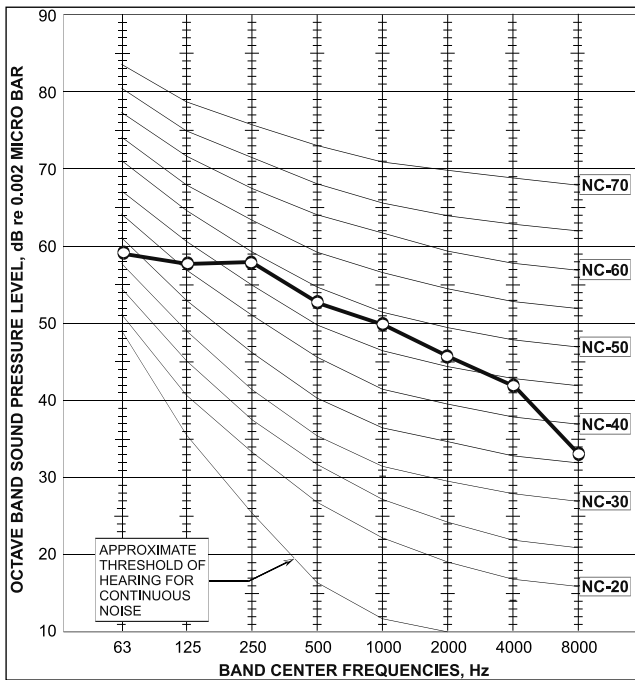

CSP(I)12 RC R410A Heating

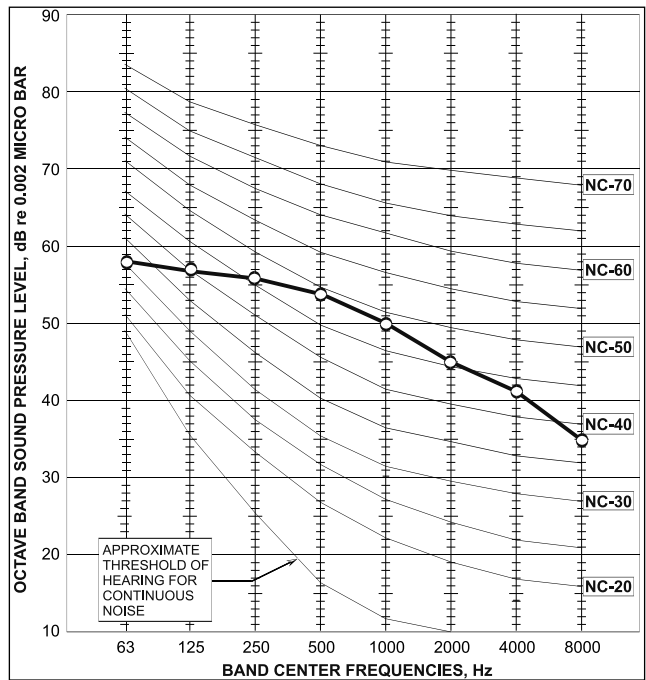

7. ELECTRICAL DATA

7.1 Single Phase Units

MODEL	ASP 9	ASP 12
Power Supply	To indoor	To indoor
	1PH-230V-50Hz	1PH-230V-50Hz
Max Current, A	6.5	7.7
Circuit Breaker,A	10	10
Power Supply Wiring No. X Cross Section mm ²	3x1.0 mm ²	3x1.0 mm ²
Interconnecting Cable RC Model No. X Cross Section mm ²	5x1.0 mm ² +2x0.5 mm ² (OCT sensor)	5x1.0 mm ² +2x0.5 mm ² (OCT sensor)
Interconnecting Cable ST Model No. X Cross Section mm ²	4x1.0 mm ²	4x1.0 mm ²

NOTE

Power wiring cord should comply with local laws and electrical regulations requirements.

8. WIRING DIAGRAMS

8.1 Indoor Unit : ASP9,12

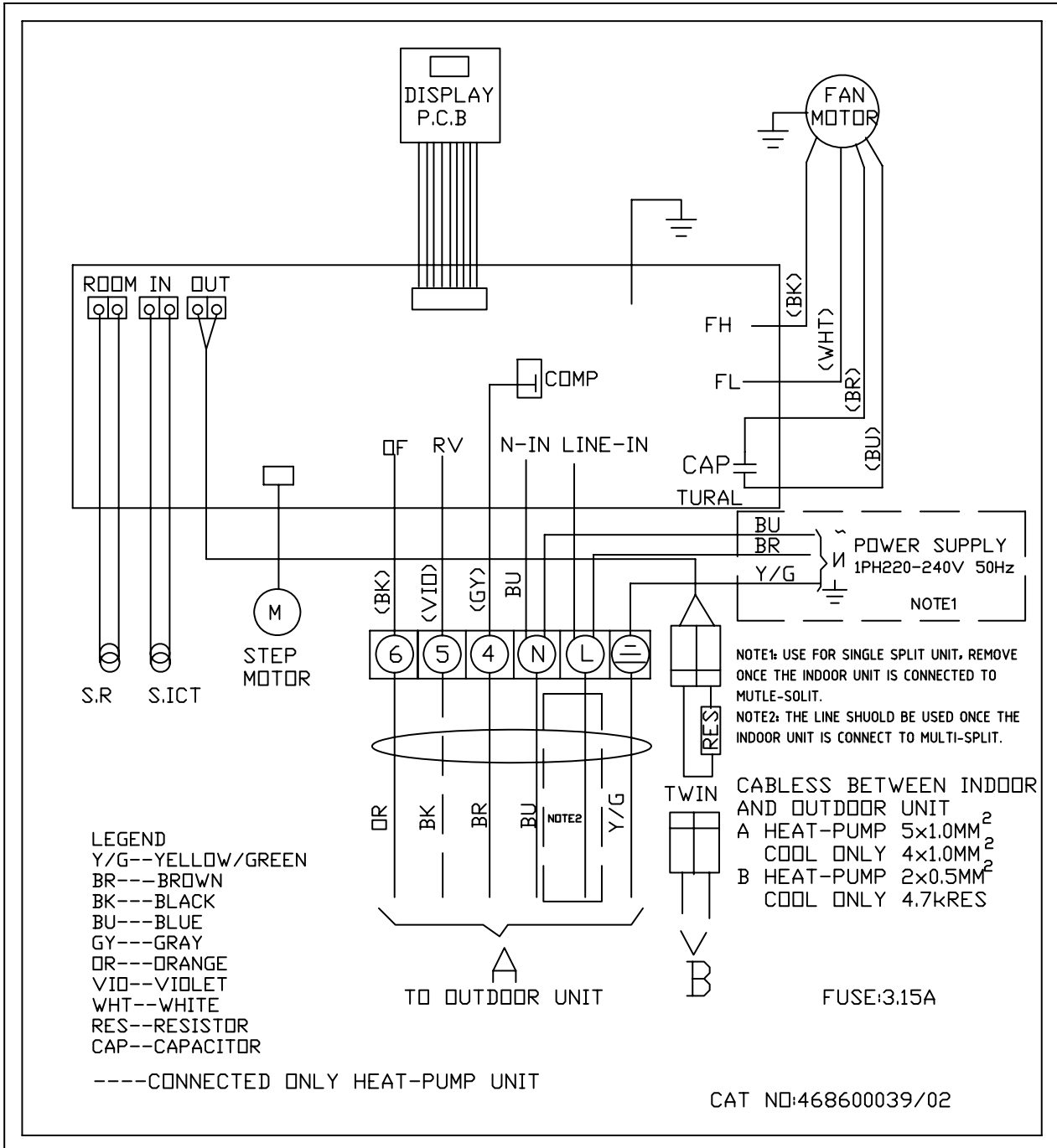

8.2 Outdoor Unit: CSP9, 12

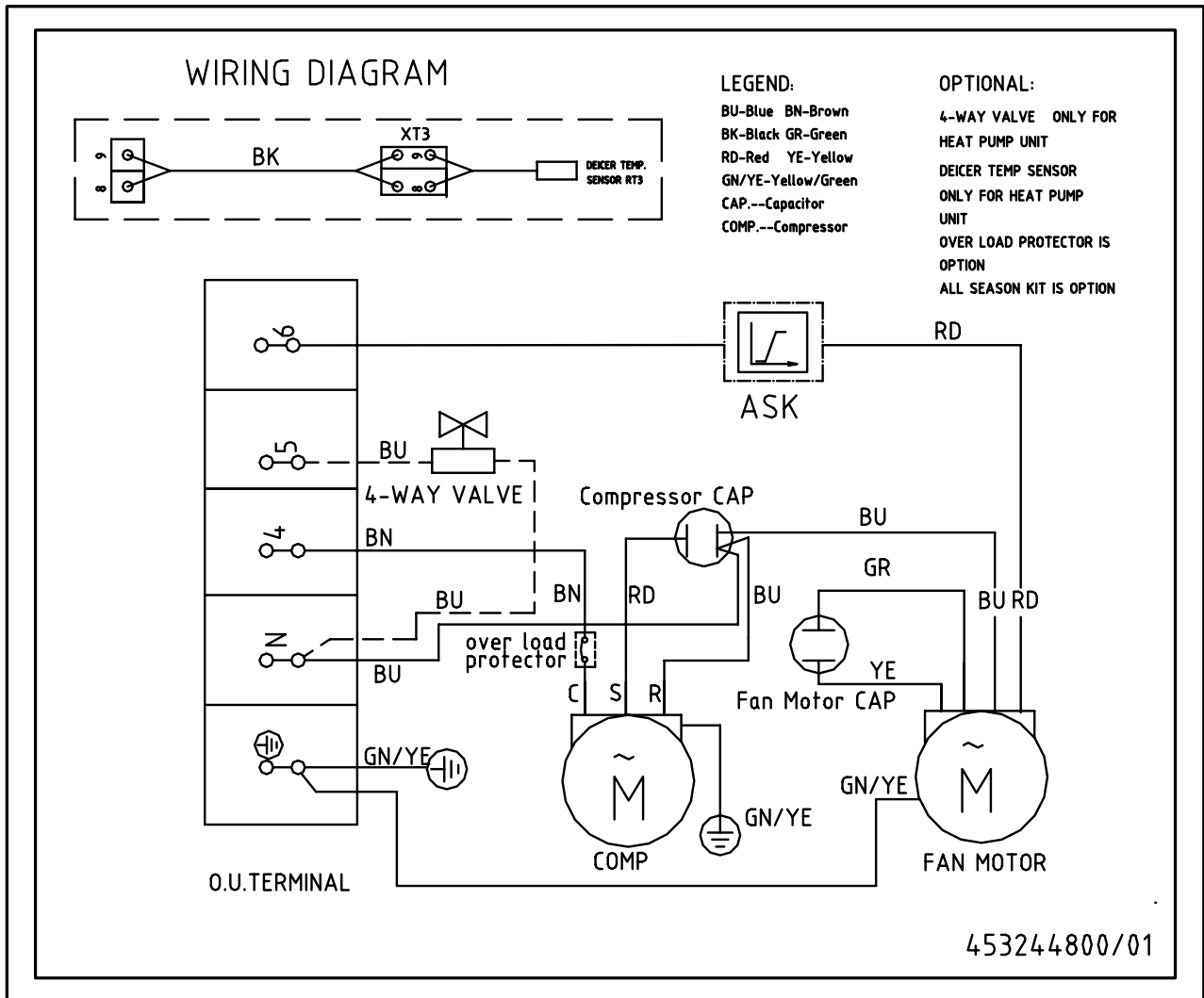

9. ELECTRICAL CONNECTIONS

9.1 ASP9, 12/CSP9, 12

indoor unit

outdoor unit

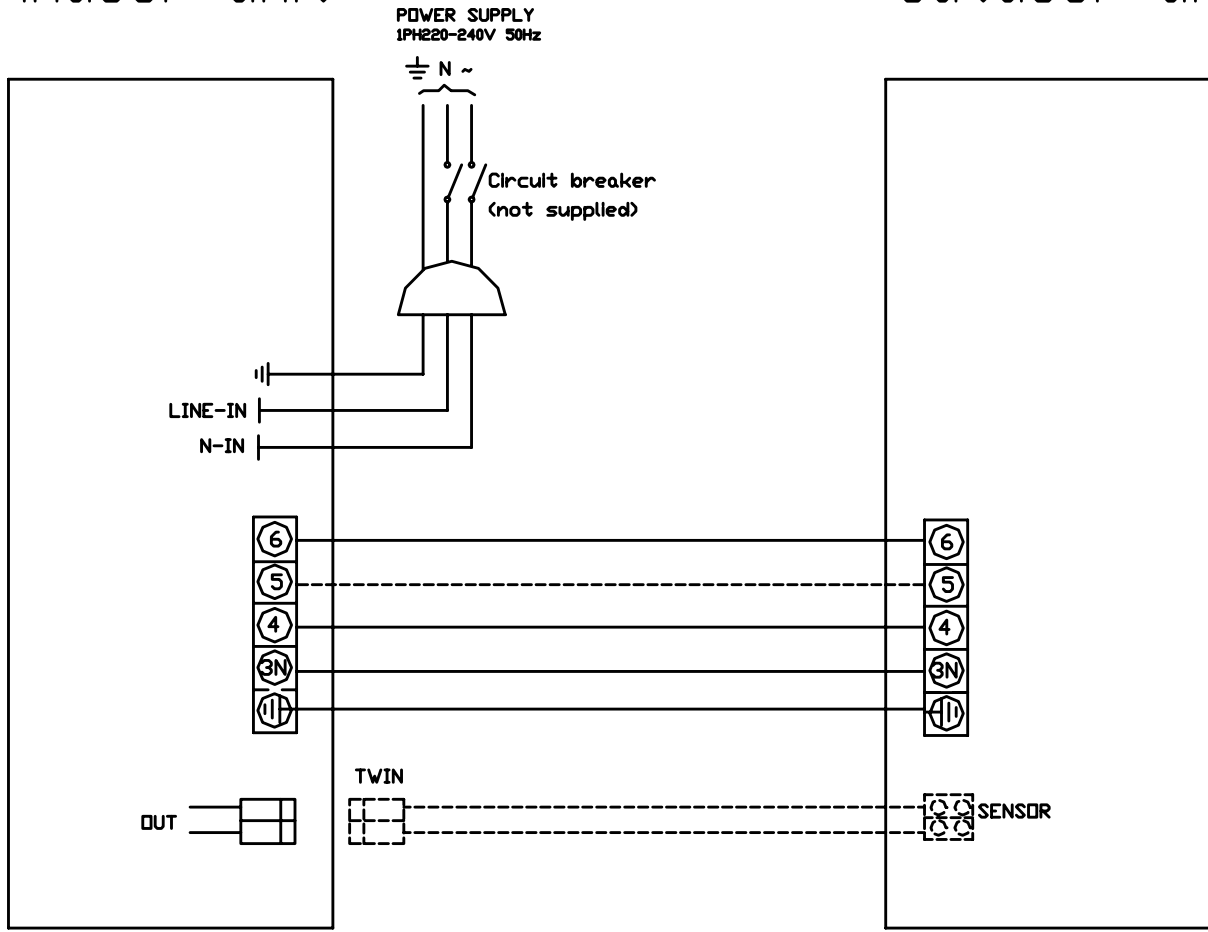

----CONNECTED ONLY HEAT-PUMP UNIT

10. REFRIGERATION DIAGRAMS

10.1 Heat Pump Models

10.1.1 Alpha9, 12 SP/CSP9, 12

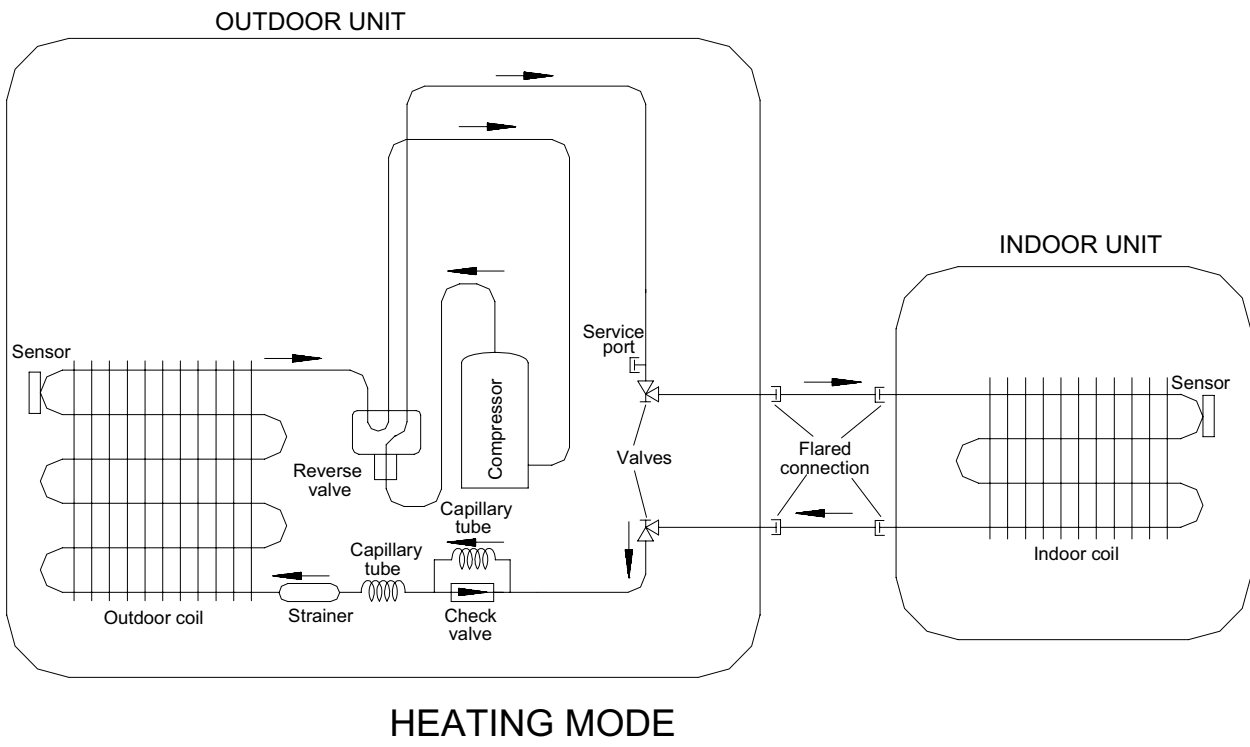
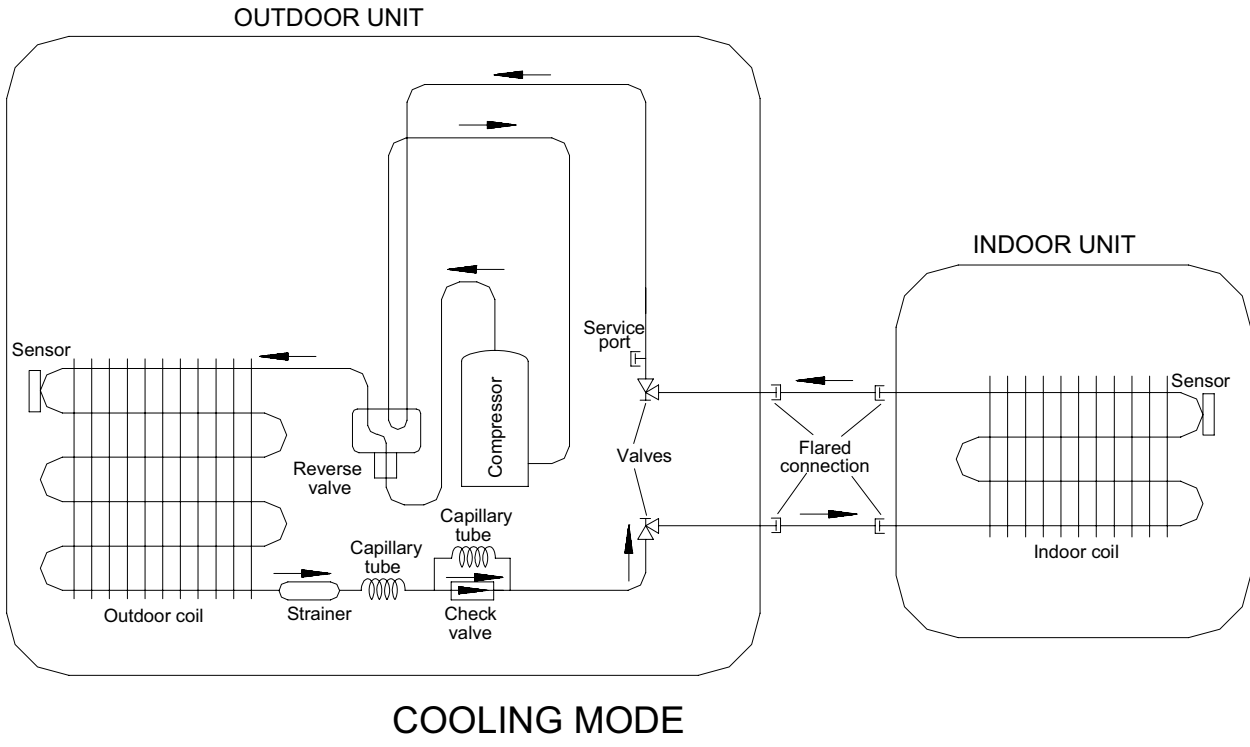

10.2 Cooling Only Models

10.2.1 Alpha9, 12 SP/CSP9, 12

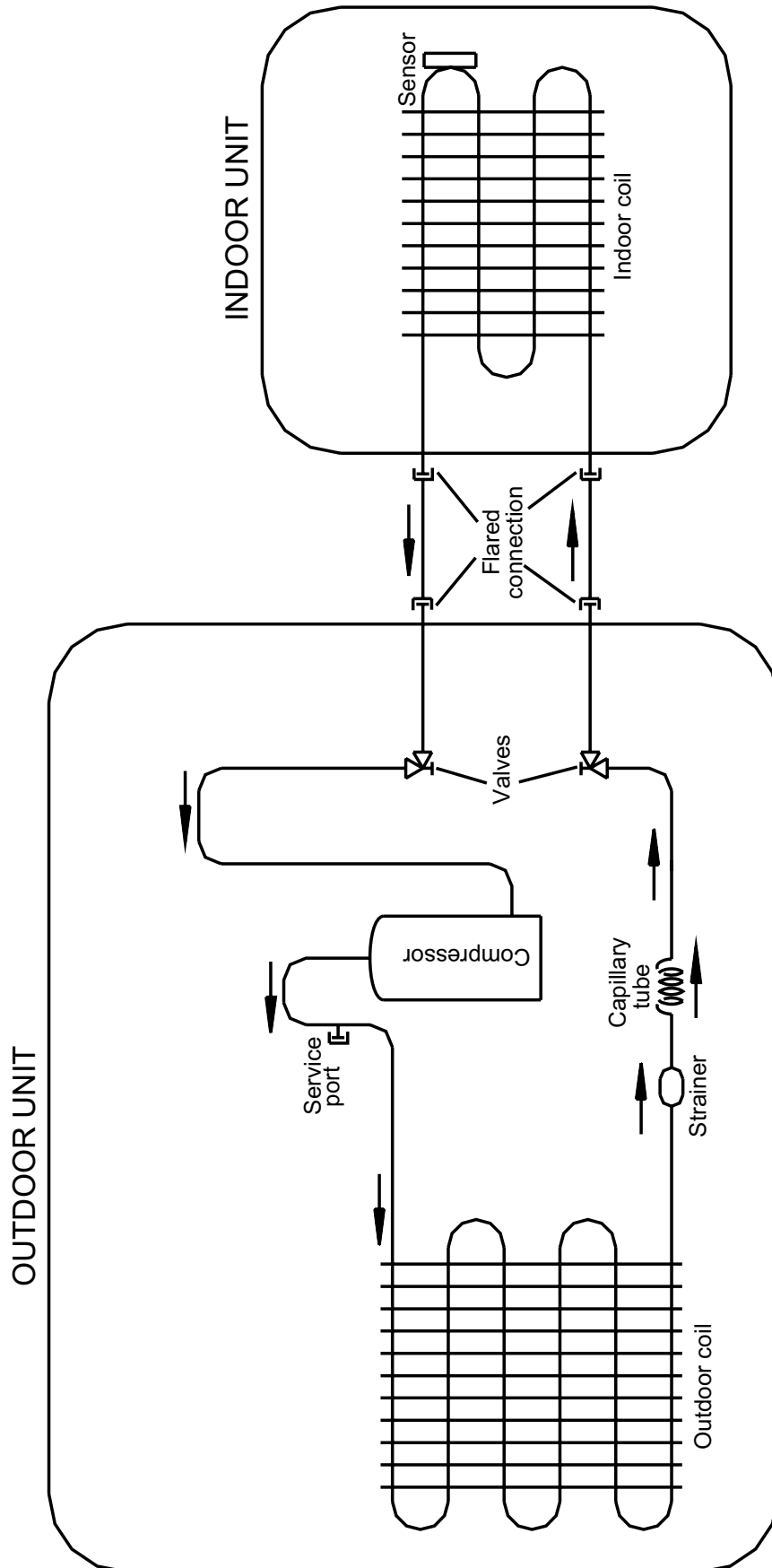

11. TUBING CONNECTIONS

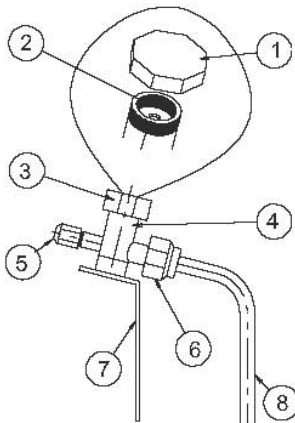
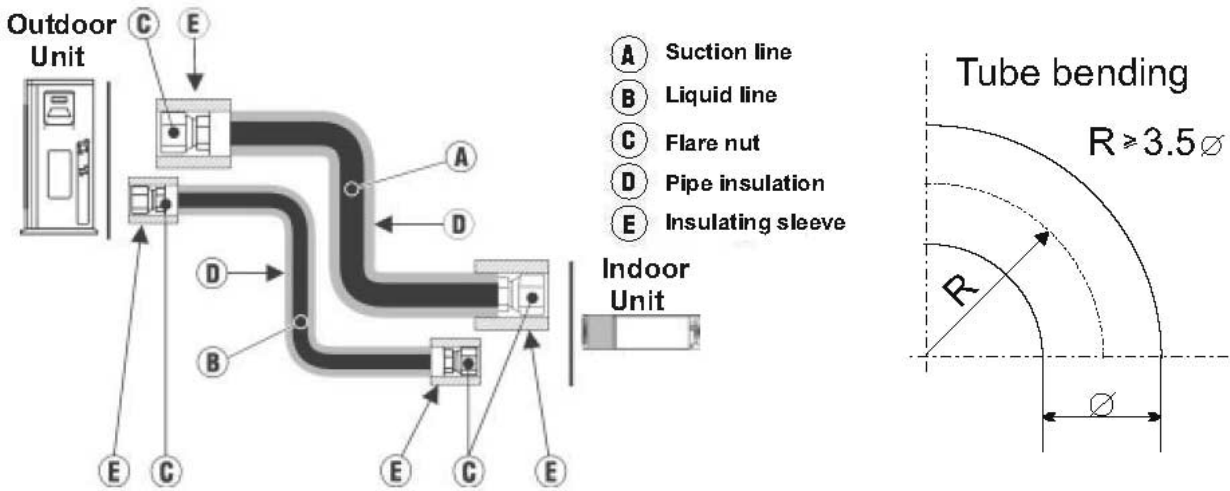

TUBE (Inch)	1/4"	3/8"	1/2"	5/8"	3/4"
TORQUE (Nm)					
Flare Nuts	11-13	40-45	60-65	70-75	80-85
Valve Cap	13-20	13-20	18-25	18-25	40-50
Service Port Cap	11-13	11-13	11-13	11-13	11-13

1. Valve Protection Cap-end
2. Refrigerant Valve Port (use Allen wrench to open/close)
3. Valve Protection Cap
4. Refrigerant Valve
5. Service Port Cap
6. Flare Nut
7. Unit Back Side
8. Copper Tube

When the outdoor unit is installed above the indoor unit an oil trap is required every 5m along the suction line at the lowest point of the riser. In case the indoor unit is installed above the outdoor, no trap is required.

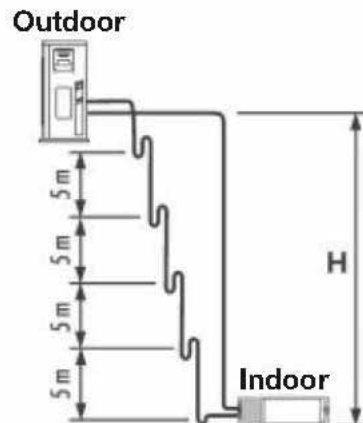

12. CONTROL SYSTEM ASP9, ASP12

12.1 Electronic Control

12.1.1 Introduction

The electronic control information is designed for service applications, and is common to the following groups of air-conditioners:

- **ST/ RC group** -Cooling only / cooling and heating by heat pump.
- **SH group** -Cooling and heating by heat pump and supplementary heater.
- **RH group** -Cooling, heating by heaters only.

12.1.2 Jumpers Settings

GROUP	J6 Setting	J2 Setting
ST / RC	Open	Open
SH	Closed	Open
RH	Closed	Closed

12.2 Legend

AC	- Alternate Current
A/C	- Air-Conditioner
ANY	- ON or OFF status
CLOCK	- ON/OFF Operation Input, (dry contact)
COMP	- Compressor
CPU	- Central Processing Unit
ELUM	- Extended Louver Upward Movement (Software Jumper)
E ² PROM, EEP	- Erase Enable Programmable Read Only Memory
HE	- Heating Element
HPC	- High Pressure Control
H/W	- Hardware
ICP	- Indoor Condensation Pump
ICT	- Indoor Coil Temperature (RT2) sensor
IF, IFAN	- Indoor Fan
IR	- Infra Red
LEVEL1	- Normal Water Level
LEVEL2/3	- Medium/High Water Level
LEVEL4	- Overflow Level
Max	- Maximum
Min	- Minimum
min	- Minute (time)
NA	- Not Applicable
OCP	- Outdoor Condensation Pump
OCT	- Outdoor Coil Temperature (RT3) sensor
OF, OFAN	- Outdoor Fan
OPER	- Operate
Para.	- Paragraph
RAT	- Return Air Temperature (RT1) sensor
RC	- Reverse Cycle (Heat Pump)
R/C	- Remote Control
RCT	- Remote Control Temperature
RH	- Resistance Heater
RT	- Room Temperature (i.e. RCT in IFEEL mode, RAT otherwise)
RV	- Reversing Valve
SB, STBY	- Stand-By
sec	- Second (time)
Sect	- Section
SH	- Supplementary Heater
SPT	- Set Point Temperature
ST	- Standard (a Model with Cooling Only)
S/W	- Software
TEMP	- Temperature
W/O	- Without
WVL	- Water Valve
ΔT	- The difference between SPT and RT. in Heat Mode: $\Delta T = SPT - RT$ in Cool/Dry/Fan Mode: $\Delta T = RT - SPT$

12.3 General functions

12.3.1 COMP operation

For each Mode including POWER OFF & SB, a Min time delay of 3 min before COMP restarting, excluding DEICING Mode

The Min operation time of COMP under different operating conditions is

Operation Mode	Min operation time of COMP
Heat, Cool or Auto Modes	3 min.
Fan, Dry, Overflow, Protection modes, or mode change	ignored

12.3.2 IFAN operation

- Min time interval between IFAN speed change in AUTOFAN Mode, is 30 sec.
- Min time interval between IFAN speed change in H/M/L Mode is 1 sec.
- IFAN speed in Heat/Cool Autofan Mode is determined according to the following table:

ΔT	IFAN Speed
$\Delta T \geq 2$	HIGH
$2 \geq \Delta T \geq 1$	MED
$1 \geq \Delta T$	LOW

where in Heat Mode: $\Delta T = SPT - RT$
 in Cool Mode: $\Delta T = RT - SPT$

Note:

- In Heat Mode, the rules in section 4.0.3 have the higher priority.
- The table above can be represent by a hysteresis curve which will minimize the switching of the IFAN relay and will minimize the change in IFAN speed:

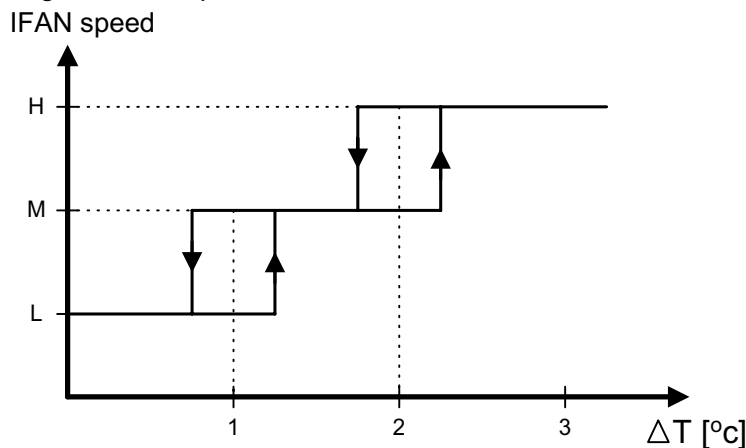

12.3.3 OFAN operation

- Min time interval between OFAN ON/OFF state change is 30 sec.
- In general, OFAN starts together with COMP.

12.3.4 HE operation

- Minimum Heaters ON or OFF time is 30 sec.
- Heaters can be activated only if IFAN is on.

12.3.5 Protections

- High pressure protection is applicable to all operating modes.
- Deicing control is valid in Heat and Auto Heat Mode only.
- Defrosting control is valid in Dry, Cool, Heat and Auto Modes.
- No reset after protection modes.

12.3.6 Thermistors operation

- Return air Temp. is detected by RAT (RT1) in normal Mode, or by RCT (R/C sensor) in I-FEEL Mode.
- Indoor Coil Temp. is detected by ICT (RT2).

12.3.6.1 Definition of thermistor faults:

- a. Thermistor is disconnected -
The thermistor reading is below -30°C .
- b. Thermistor is shorted -
The thermistor reading is over 75°C .
- c. Thermistor Temp reading doesn't change (irrelevant for RT1) -
 - (i) This test is performed only once after a unit is switched from OFF/STBY to operation. At the first occurrence of 10 min continuous COMP operation, the current ICT & OCT are compared with those when the COMP was switched from OFF to ON 10 min before. If the ΔT is less than 3°C , the thermistor is regarded as defective.
 - (ii) The ICT and OCT no-change error can be disabled together by connecting a 4.7 kohm resistor (5%) to the OCT connector. These resistors are equivalent to a thermistor at $43\pm 1^{\circ}\text{C}$ and $48\pm 1^{\circ}\text{C}$ respectively.
 - (iii) Connecting a 4.7 k resistor to the ICT connector will disable the ICT no-change error only.

12.3.6.2 Handling the thermistor faults in a COMP unit

- i. ICT/OCT thermistor is disconnected or shorted -
The invalid thermistor temperature is replaced by 43°C, so that the unit can continue the normal operation. All protections related to that faulty thermistor will be disabled. For example, in case of any ICT fault, the ICT high pressure protection in Heat Mode and ICT defrost protection in Cool Mode will not operate anymore. The same is also applied to the OCT fault.
- ii. RAT thermistor is disconnected or shorted –
The RAT will be derived from the ICT by using the equations :
- Heat Mode: $RAT = ICT / 2.3$
Cool Mode $RAT = ICT * 4$

Notes:

- In case of any thermistor failure, the STBY LED will be blinking until the fault condition is corrected.
- User can use the system diagnostics function to find out the nature of the thermistor faults.

- i. RAT thermistor is disconnected or shorted –
System will operate continuously in the last IFAN & WVW status when turned ON.

Notes:

- As in the COMP unit, the STBY LED will be blinking to indicate a thermistor fault. And, the user can use the system diagnostics function to find out the nature of the fault.

12.4 Cooling Mode - General

- 1) Room Temperature, RT, is detected by
 - RAT in normal operation, or
 - RCT (R/C sensor) in I-FEEL mode.
- 2) The resolution of RT is 1°C.
 - RT is activating COMP/WVL if (RT > SPT), and
 - RT is stopping COMP/WVL if (RT ≤ SPT).
- 3) Indoor Coil Temp is detected by ICT (RT2).
- 4) Outdoor Coil Temp is detected by OCT (RT3).
- 5) OFAN OPERATIONS
 - OFAN starts together with COMP in general.

12.4.1 Cooling

Mode: Cool, Auto (at Cooling)
 Temp: Selected desired temperature.
 Fan: HIGH, MED, LOW
 Timer: Any
 I Feel: On or Off

Control function

Maintains room temp at desired level by comparing RT and SPT.

(RT - SPT) [°C]

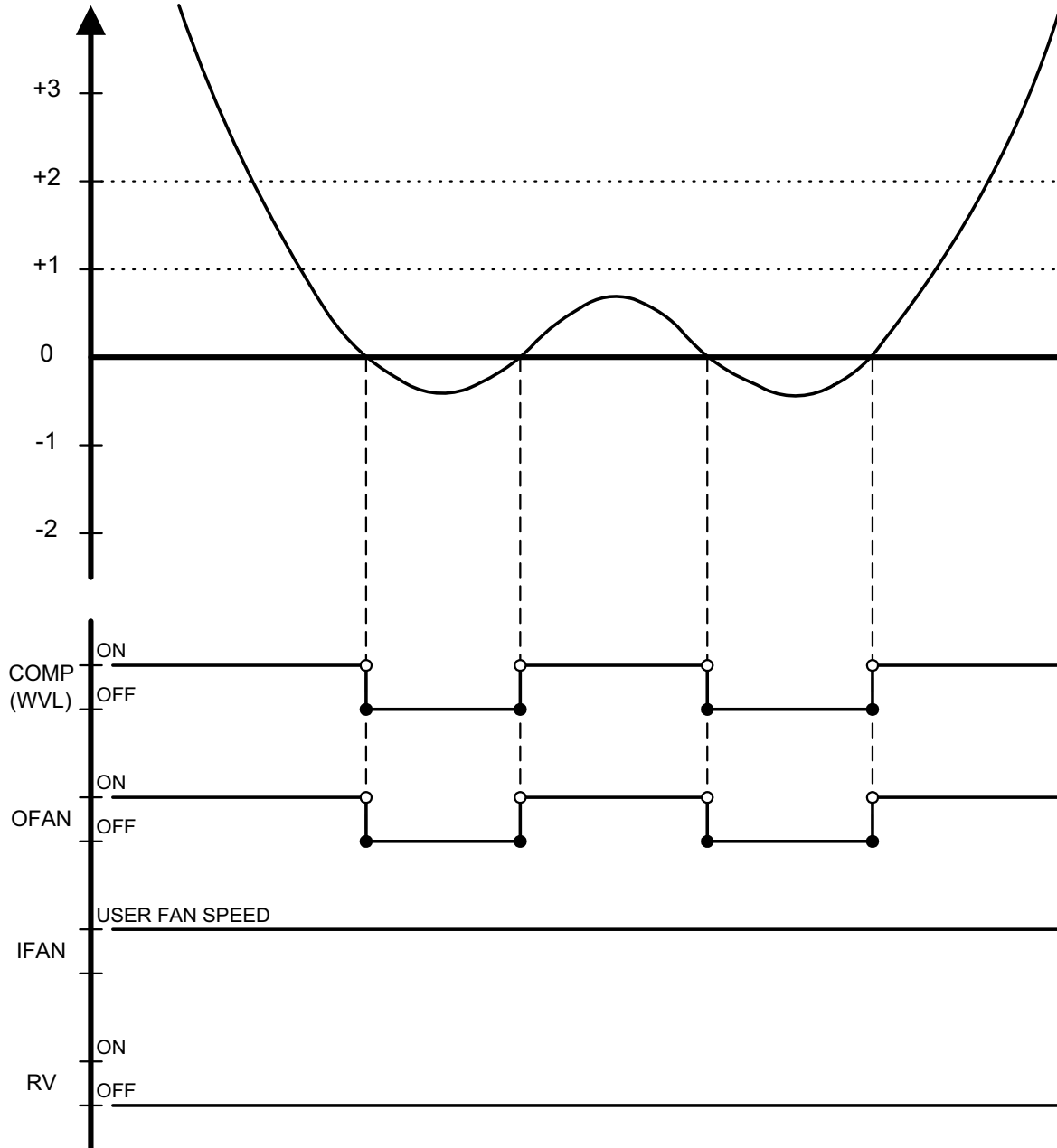

Note:

- 1) IFAN is always running at High, Medium or Low speed selected by user.
- 2) In IFEEL mode, the Room Temperature (RT) is the RCT from a R/C. Otherwise, the RT is the RAT from the Room Thermistor.

12.4.2 Cooling with Autofan

Mode: Cool, Auto (at cooling)
 Temp: Selected desired temperature
 Fan: Auto
 Timer: Any
 I Feel: On or Off

Control function

Maintains room temp at desired level and controls the IFAN speed for optimal comfort.

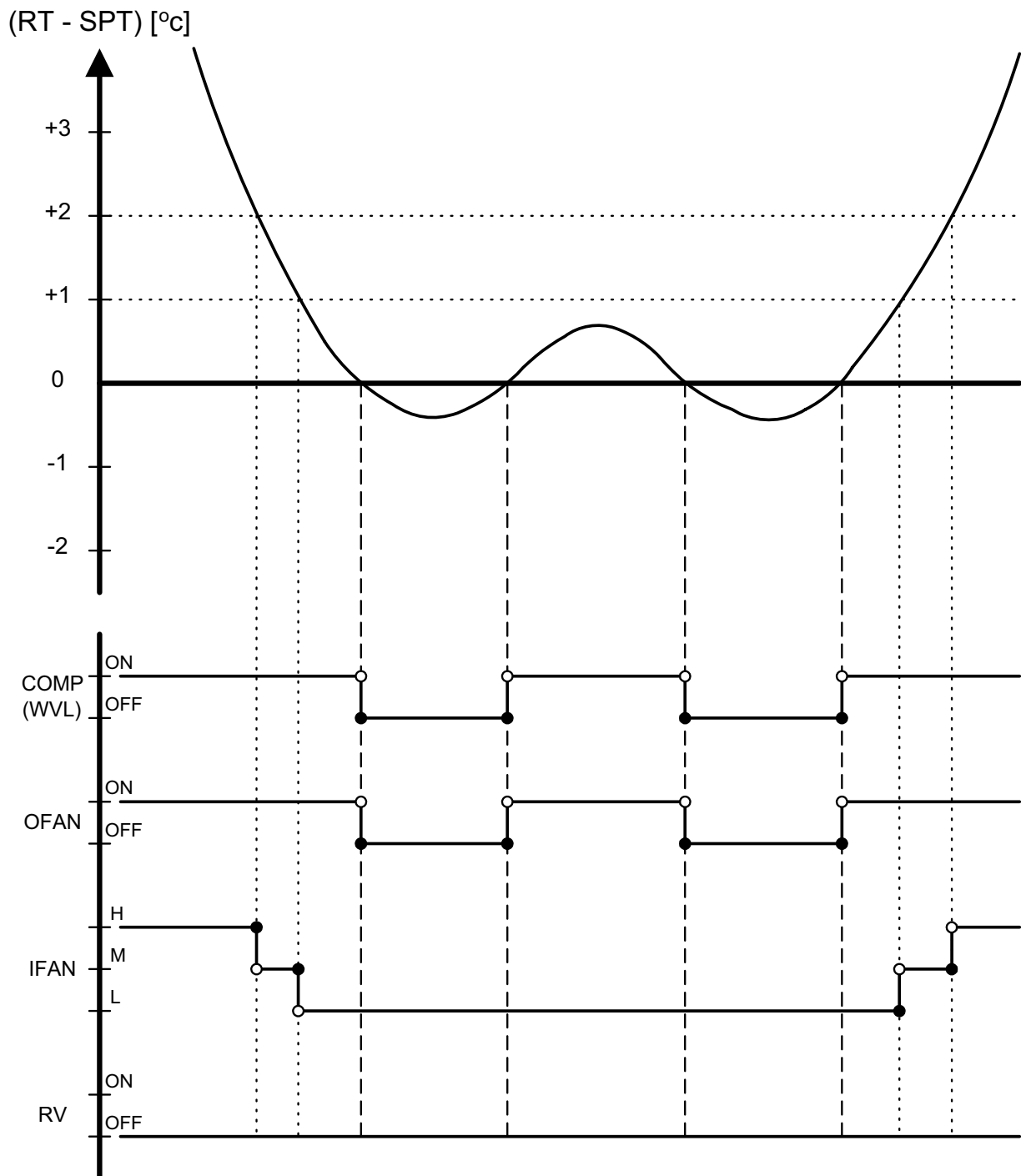

12.5 Heating Mode

12.5.1 Heating Mode - General

- In heating Mode, temp. compensation schedule will be activated for wall mounted units.

SPT [°C]	Add to SPT	
	I-FEEL ON	I-FEEL OFF
$18 \leq SPT \leq 27$	0 °C	+2 °C
$27 < SPT \leq 30$	0 °C	+3 °C

Notes :

- No compensation will be activated in Forced operation modes

12.5.2 IF operating rules

- As a general rule for **RC and SH groups**, when **COMP is ON**, excluding protection modes, IFAN will be switched ON if
- ICT > 35°C or
at the IFTC 30 sec after the COMP is switched ON. In this case, the IFAN will be started at low speed.

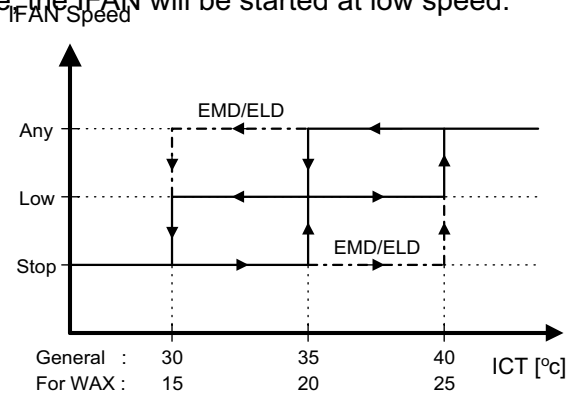

Notes :

- In **SH or RC group**, if HE is set to OFF due to low ICT, IFAN will be switched to LOW and will be turned OFF after 30 sec.
- An exception to this rule (4.0.3.a) is the Back-up mode for SH.
- In **RC and SH groups**, whenever **COMP & HE are both OFF**, excluding protection modes, IFAN operation will be according to the following:

In **other models** IFAN will operate in low speed for 30 sec and then stop. If COMP is OFF for more than 3 minutes and IFEEL Mode is inactive, IFAN will operate in low speed according to the following graph:

IFAN (Low Speed)

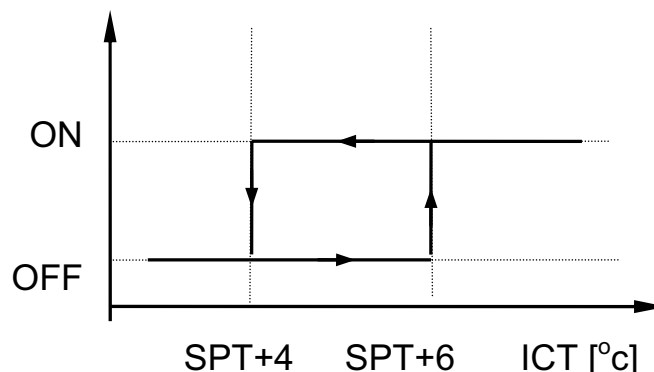

12.5.3 HE operation

- For **all Groups**, HE can be ON only when IFAN is ON.
- For **all Groups**, HE switches to OFF when $ICT > 50\text{ }^{\circ}\text{C}$, and is activated again when $ICT \leq 45\text{ }^{\circ}\text{C}$.
- In **SH or RC group**, HE operation is limited by the following graph:

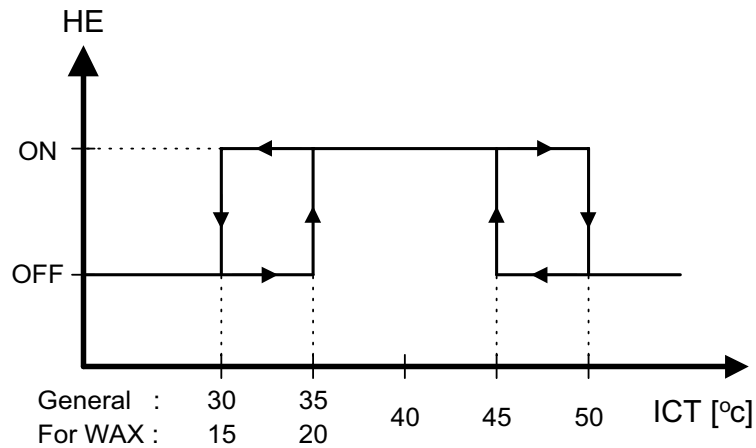

- Back-up mode for **SH group**

After COMP has been working for 5 minutes, HE & IFAN are activated even if the ICT is still below 35°C. This situation is called Back-up Mode. Both HE & IFAN will work in Back-up Mode until the ICT reaches 35°C. Then, the operation goes on in the usual mode .

12.5.4 Heating, RC or SH Group

Mode: Heat, Auto (at heating)
 Temp: Selected desired temperature
 Fan: HIGH, MED, LOW
 Timer: Any
 I Feel: On or Off

Control function

Maintains room temp. at desired level by comparing RAT or RCT to SPT.

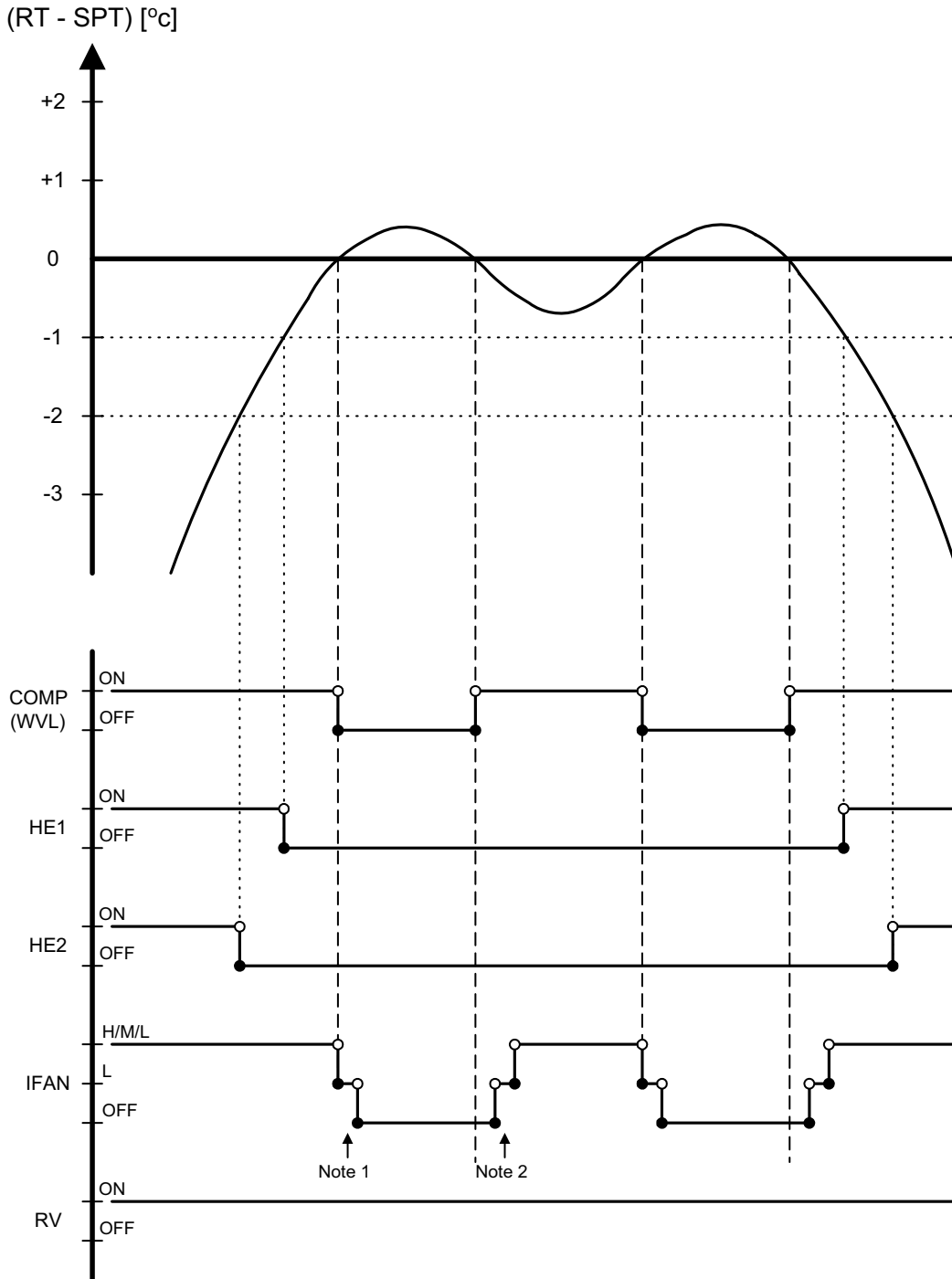

12.5.5 Heating, RC or SH Group with Autofan

Mode: Heat, Auto (at heating)
 Temp: Selected desired temperature
 Fan: Auto
 Timer: Any
 I Feel: On or Off

Control function

Maintains room temp at desired level by controlling COMP, IFAN and OFAN.

(RT - SPT) [°c]

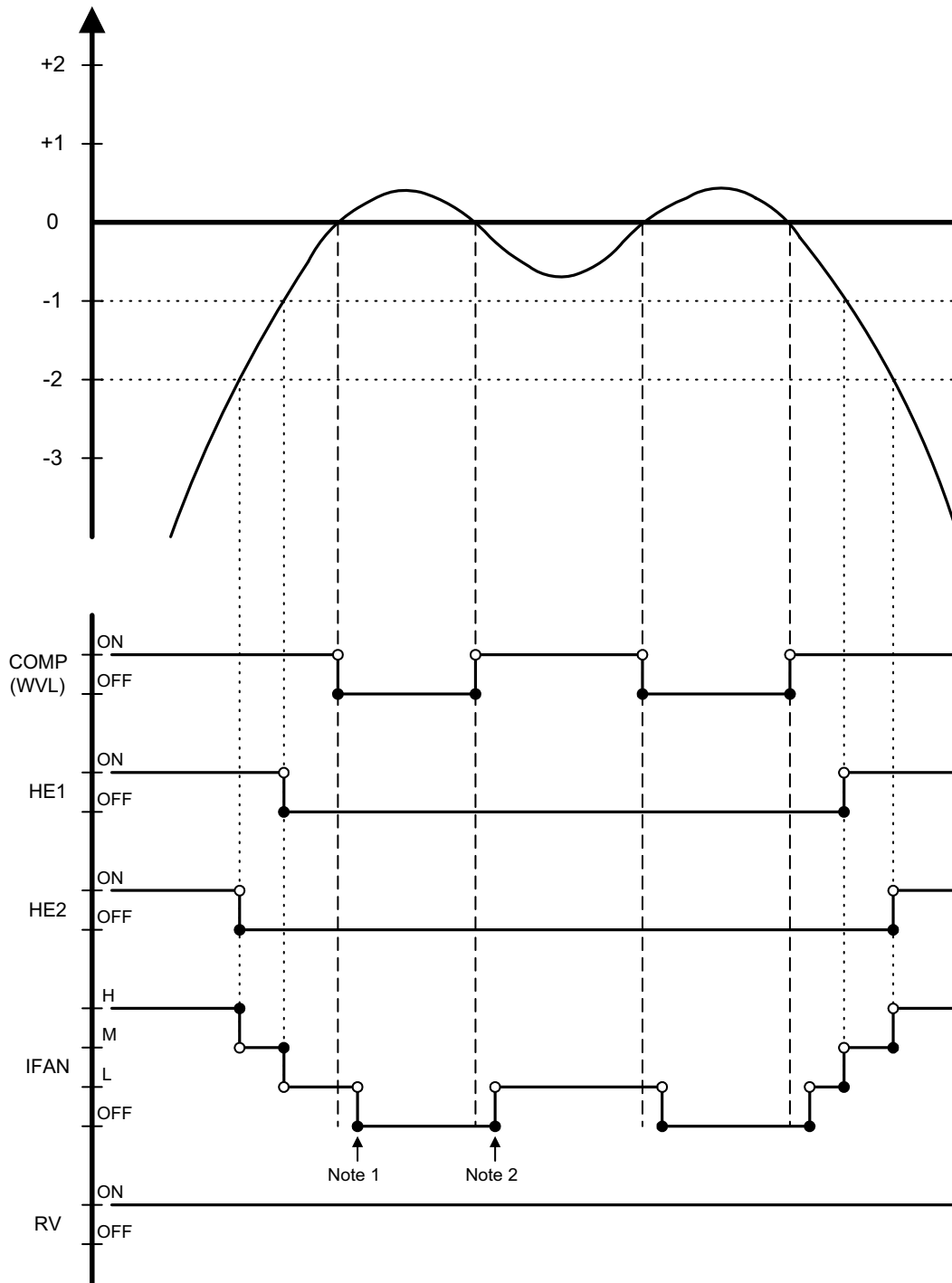

12.5.6 OFAN operation is controlled by the graph below when

1. (RAT \geq SPT - 2°C), AND
2. (ICT \geq 45°C), AND
3. (COMP is ON)

Otherwise, OFAN runs together with COMP.

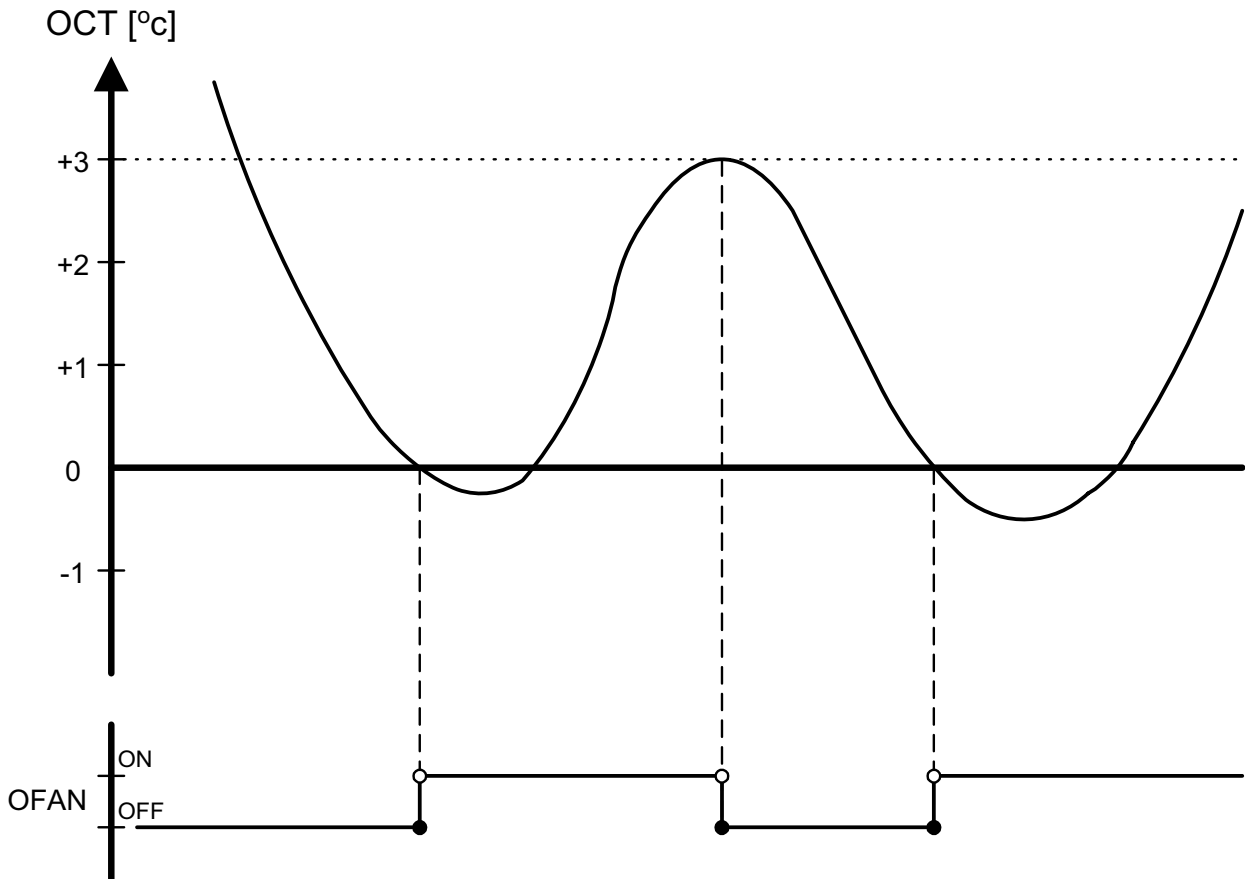

12.6 Automatic Cooling or Heating

12.6.1 Automatic Cooling or Heating - General

- Switching-temperature between Cooling and Heating is $SPT \pm 3^{\circ}\text{C}$.
- Autofan in Automatic Cooling and Heating Mode will activate “Cooling with Autofan Mode” and “Heating with Autofan Mode” respectively.
- When the Auto Mode is started with $SPT \pm 0^{\circ}\text{C}$, the unit will not select Auto Heat or Auto Cool mode immediately. Instead, the unit will be in a temporary Fan Mode with IFAN operating at low speed. The proper Auto Heat mode or Auto Cool will be started whenever the RT reaches $SPT-1^{\circ}\text{C}$ or $SPT+1^{\circ}\text{C}$ respectively.
- For RC & SH units, Mode change between Auto Heat & Auto Cool Modes is possible only after the COMP has been OFF during the last T minutes.

Mode Change	time, T
Auto Cool to Auto Heat	3 min
Auto Heat to Auto Cool	4 min

- When unit is changed from Cool/Dry mode to Auto Mode, the unit will continue to operate at (Auto) Cool Mode until the conditions for switching from Auto Cool to Auto Heat are satisfied. Similarly, when unit is changed from Heat Mode to Auto Mode, the unit will continue to operate at (Auto) Heat Mode until the conditions for switching from Auto Heat to Auto Cool are satisfied.

12.6.2 Auto Cooling or Heating, RC or SH Groups

- Mode: Auto
- Temp: Selected desired temperature
- Fan: Any
- Timer: Any
- I Feel: On or Off

Control function

Maintains room temp at desired level by selecting between cooling and heating modes.

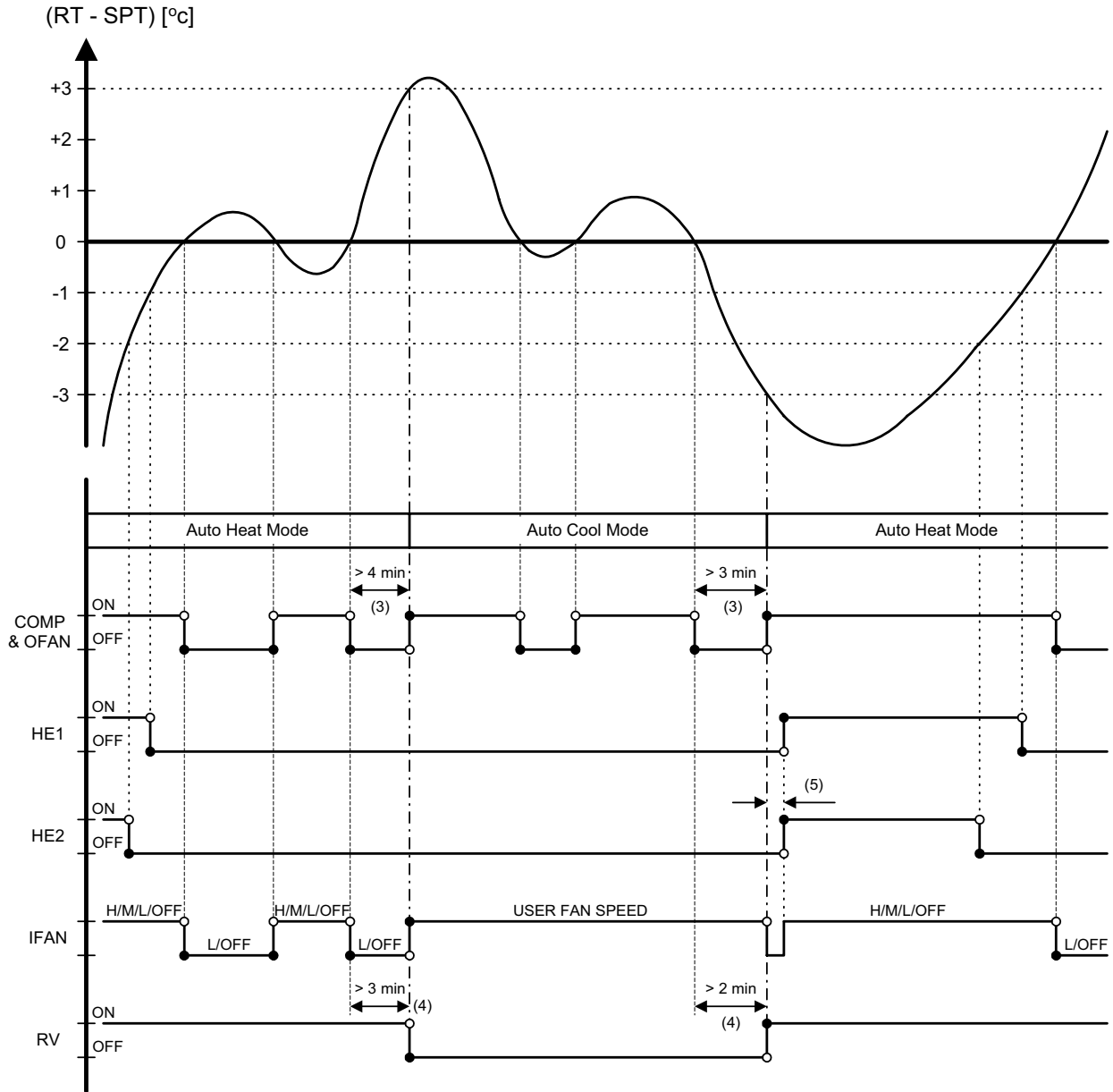

12.7 Dry Mode

12.7.1 Dry, ST or RC group

Mode: Dry
 Temp: Selected desired temp
 Fan: Low (automatically selected by software)
 Timer: Any
 I FEEL: Any

Control function

Reduce room humidity with minimum temp. fluctuations by operating in Cool Mode with low speed IFAN.

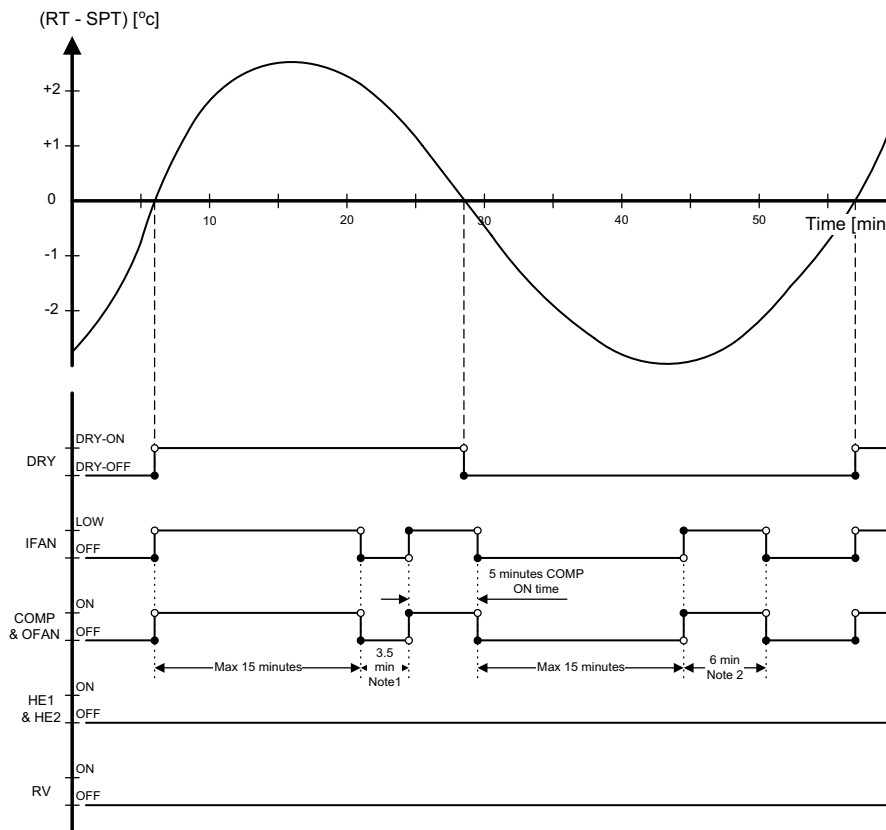

Notes :

- When Dry is ON, the COMP is forced OFF for 3.5 min (longer than the 3 min Min COMP-Off time) after every 15 min of continuous COMP operation.
- When Dry is OFF, the COMP is forced ON for 6 min (longer than the 3 min Min COMP-On time) after every 15 min of continuous COMP OFF time.
- When Dry is changed from ON to OFF or vice versa, the limits mentioned in (1) & (2) are ignored. The COMP operation is only controlled by the 3 min Min OFF time and 1 min Min ON time.
- In Dry Mode, IFAN is LOW when COMP is ON, and is OFF when COMP is OFF.

12.8 Protection

12.8.1 Cooling Mode Protections

Indoor Coil Defrost

Mode: Cooling, Dry, Auto
 Temp: Selected desired temp.
 Fan: Any
 Timer: Any
 I Feel: On or Off

Control Function

Protect the indoor coil from ice formation at low ambient temperature.

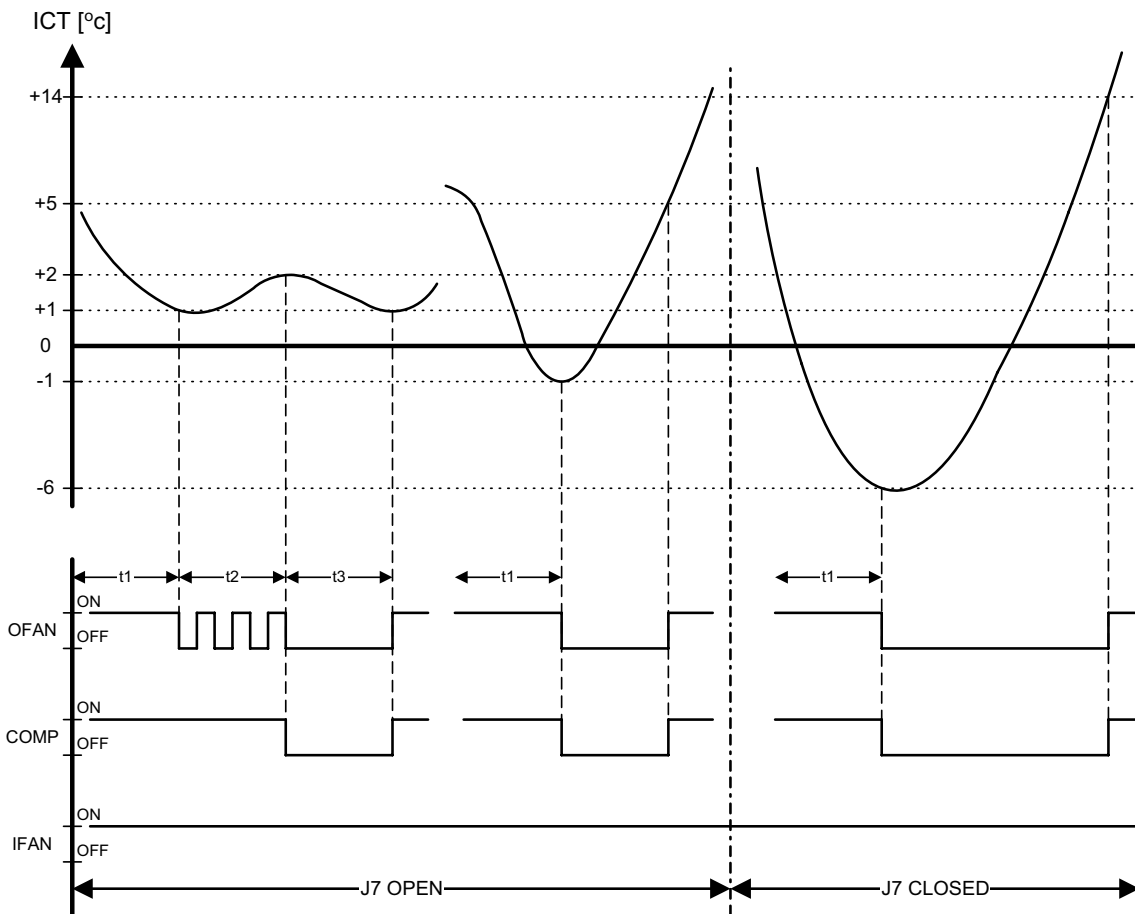

t1 = 5 min minimum for each COMP starting
 t2 = OFAN cycling (alternate between ON and OFF every 30 sec) for 20 min maximum
 t3 = COMP and OFAN stop for 10 min minimum

Notes:

- When J7 is closed (connected), OFAN cycling is cancelled and the set temperature for COMP & OFAN cut-out and cut-in are changed. COMP & OFAN are forced OFF when $ICT \leq -6^{\circ}C$, and are kept OFF until $ICT > 14^{\circ}C$.
- For WAX model, the defrost processes is simpler. When J7 is open, COMP & OFAN are forced OFF when $ICT \leq -1^{\circ}C$, and are kept OFF until $ICT > 5^{\circ}C$. When J7 is closed, the WAX defrosting process is the same as that of the other models (R.H.S. of the graph above). In both cases, the ICT checking in t2 and t3 are not applied.

12.8.2 High Pressure Protection

Mode: (Auto) Cooling or Dry
 Temp: Selected desired temp.
 Fan: Any
 Timer: Any
 I Feel: On or Off

Control Function

To protect the COMP from the high pressure built-up in the outdoor coil during normal cooling operation, by switching OFF the IFAN and COMP.

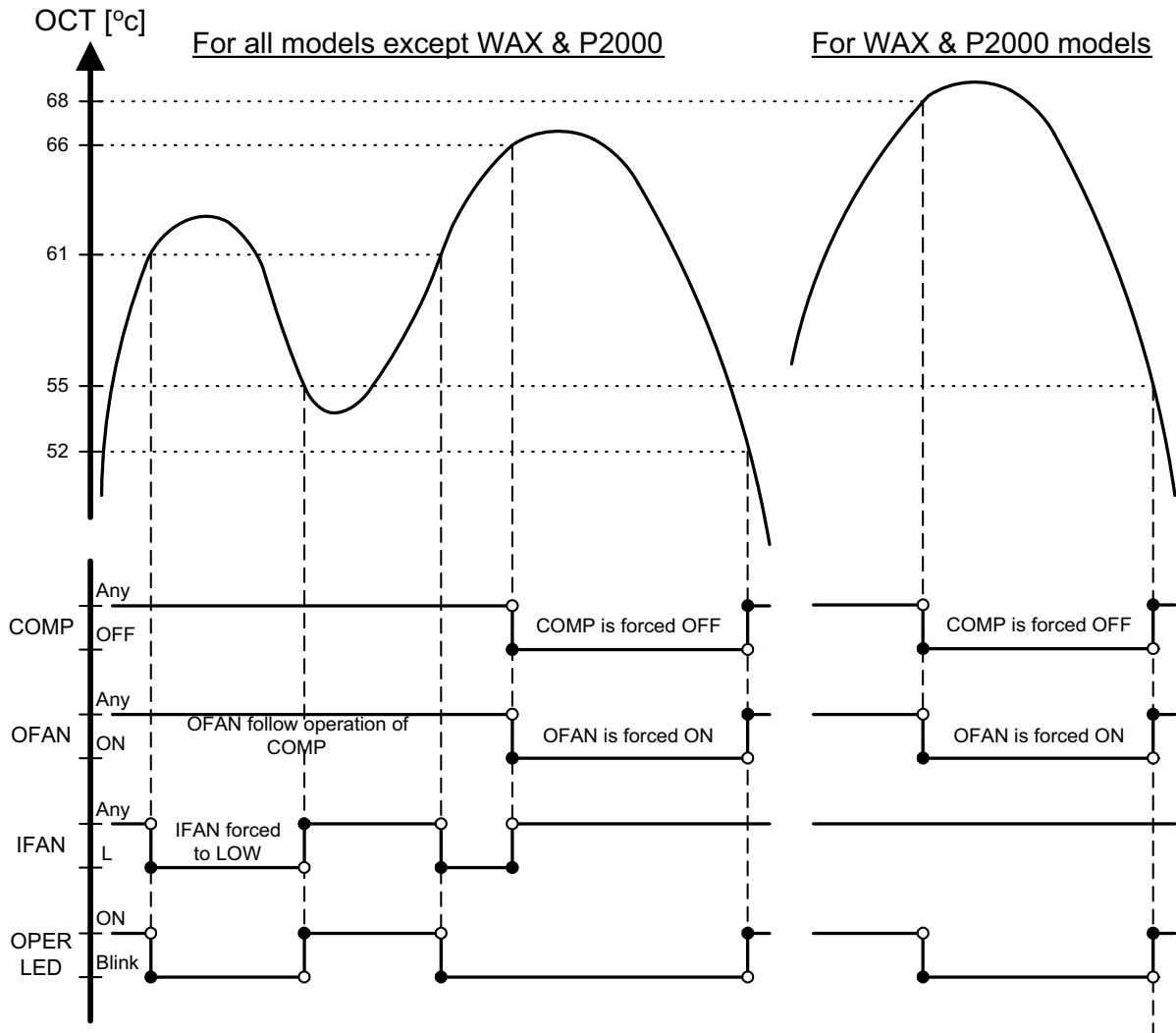

Note:

- The ICT is also monitored during Cool and Dry mode, in case the RV control circuit is faulty. Whenever ICT reaches 70°C, which indicates a high pressure in the indoor coil, the COMP will be forced off automatically. The COMP can be turned on again only after the ICT is under 70°C again and after the 3 min COMP ON delay time. The OPER LED will not blink in this case.

12.8.3 Heating Mode Protections

Outdoor coil Deicing (excluding RH Group)

Mode: Heating, Auto (at heating)

Temp: Selected desired Temp

Fan: Any

Timer: Any

I FEEL: Any

Control function

Protects the Outdoor coil from ice formation by controlling COMP & RV operation.

Scope

This new deicer is designed to operate at extreme temp conditions. The deicing cycle could be triggered from:

1. OCT temp and time between two consecutive deicing cycles.
2. Detection of ice forming by change of the OCT temp.

Both algorithms adjust the time between deicing cycles to optimize the A/C performance. The algorithm will automatically increase the time between deicing cycles and reduce the deicing cycle as needed.

The algorithm uses EEPROM data to operate.

Deicing procedure

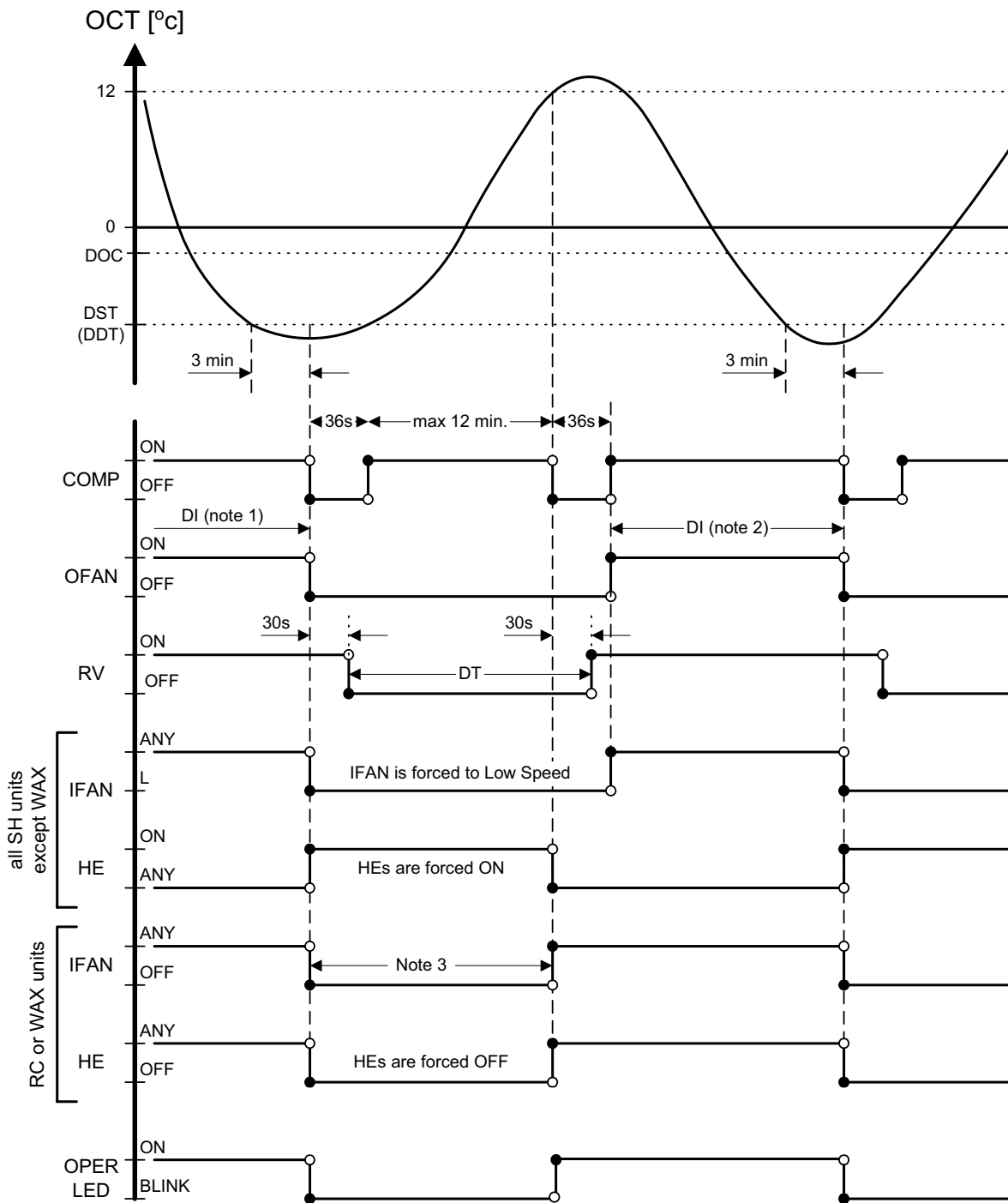

Notes :

- At the first COMP activation after SB or OFF, if (OCT < 0°C), then DI = 10 min, else DI = 40 min.
- In the following Deicing cycles, the time interval between two Deicing cycles activation is between 30 to 80 min (refer to the flow chart).
- For RC group, HEs are forced OFF. IFAN operation is as in Heat Mode, Sect 4.0.3.a, i.e. IFAN will be set to OFF when ICT < 30°C. For WAX, the IFAN is simply forced OFF.
- For SH group, HEs are forced ON and IFAN is forced to operate in Low speed, regardless of the ICT and difference between RAT & SPT.

12.8.4 High pressure protection (excluding RH Group)

Mode: (Auto) Heating
 Fan: Any
 Timer: Any
 I Feel: On or Off

Control Function

Protect the Compressor from high pressure by switching OFF the OFAN and COMP.

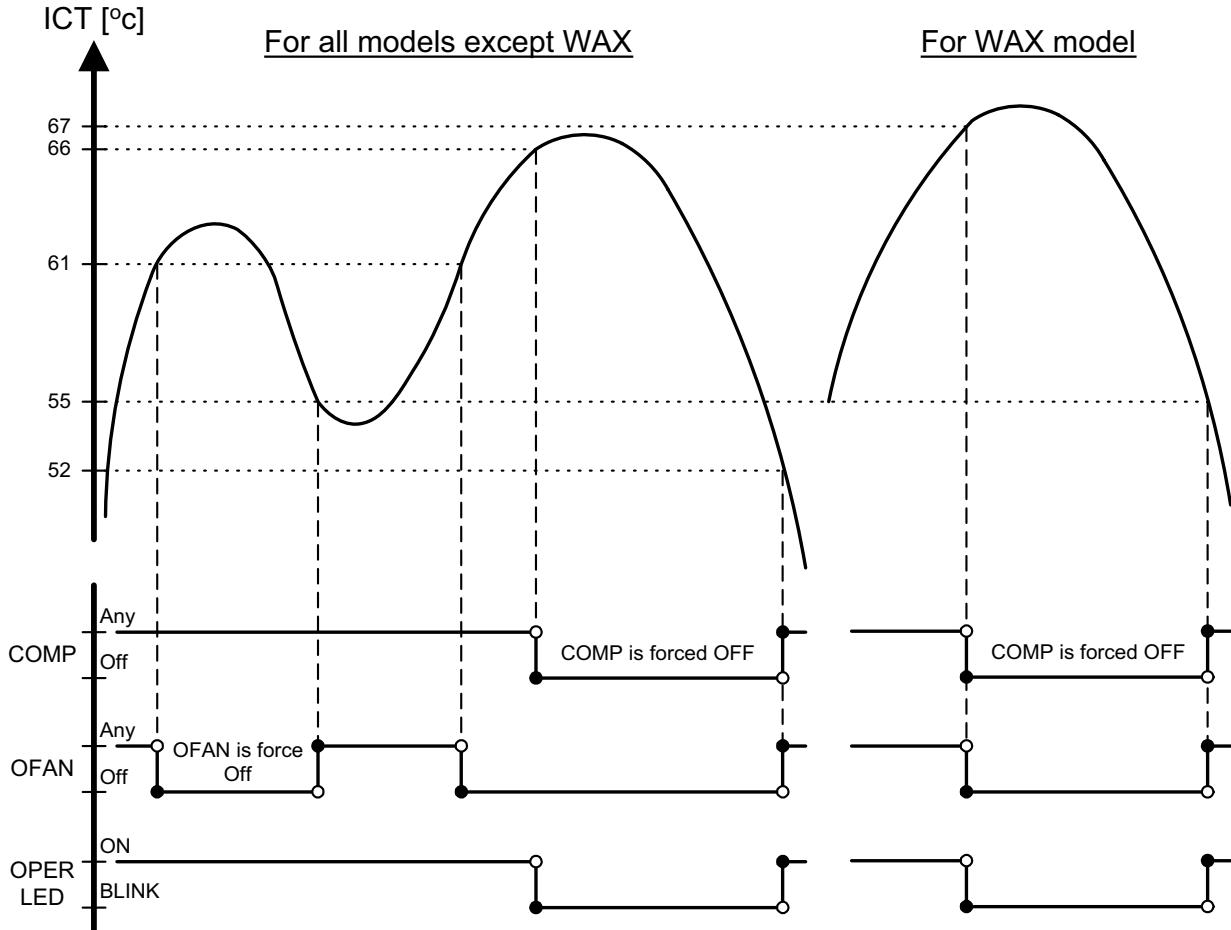

Notes:

- IFAN, HE1 and HE2 will be activated according to the relevant Heating Mode Sect.
- In case of any malfunction in the relay control circuit, the OCT is also monitored during heating mode. Whenever OCT reaches 70°C, which indicates a high pressure in the outdoor coil, the COMP will be forced off automatically. The COMP can be turned on again only after the 3 min COMP ON delay and the OCT is under 70°C. The OPER LED will not blink in this case.

12.9 Timer

Mode: Any
Temp. Selected desired temp
Fan: Any
Timer: Timer On, Timer Off
I Feel: On or Off

Control function

- Starts or stops the unit operation after pre-set time. If RC-1 is used, the timer setting will be (0.5 - 24 Hr) from the moment the timer is set. The minimum resolution is 30 minutes.
If RC-2 or later version of remote controls is used, the timer setting will be (0:00 - 23:50) real time with 10 minutes resolution.

- After power failure, all pre-set timers are cleared. The system is forced to STBY mode and the Timer LED indicator is blinked to indicate the situation. The LED keeps blinking until the timer settings can be reloaded from a R/C message.

Note: If all timers are inactive, the system will not be forced OFF after the power failure. The last OPER/STBY status will be loaded from the EEP instead.

- When the A/C receives any valid message from a R/C, the current ON/OFF timer settings will be replaced by the new timer settings in the R/C message.

Note: The following timer related operations will not affect the A/C operating mode (Heat/Cool/Auto/Dry/Fan) setting.

- Set ON/OFF timer
- Clear ON/OFF timer
- R/C ON Timer is time-up
- R/C OFF Timer is time-up

E.g. When a STBY A/C unit (with Cool Mode setting in its EEP) is turned on by the ON-TIMER of a R/C with heat mode setting, the A/C will start in Cool Mode.

12.10 Forced Operation

Forced operation allows units to start, stop and operate in Cooling or Heating in pre-set temperature according to the following table:

Forced operation mode	Pre-set Temp for : WMZ, WMF, WNG models
Cooling	22°C
Heating	28°C

Note:

- While under the forced operation, the temperature compensation schedule.
- The forced operation is activated when the mode button on the Display Board is used to switch the unit to Cool or Heat mode.
- The IFAN is always set to Autofan Speed in forced operation.

12.11 Sleep Mode

- Mode: Any
- Temp: Set – desired temperature selected
- Fan: Any
- Timer: Interact with Sleep Timer as described in sect 12.2
- I Feel: On or Off

The Sleep mode is activated by using the sleep button on the R/C. In Sleep Mode, the unit will automatically adjust the SPT to turn up/down the room temperature (RT) gradually to provide maximum comfort to the user in sleep.

Sleep is treated as TIMER function. Therefore, the TIMER LED is activated similar to TIMER function.

12.11.1 Adjustment in Sleep Mode

1. in cool, auto cool or dry modes, the SPT adjustment is positive (from 0 to +3°C).
2. In heat or auto heat modes, the SPT adjustment is negative (from 0 to -3°C).
3. In other modes, there is no SPT adjustment.
4. The SPT adjustment is cancelled when the Sleep mode is cancelled.

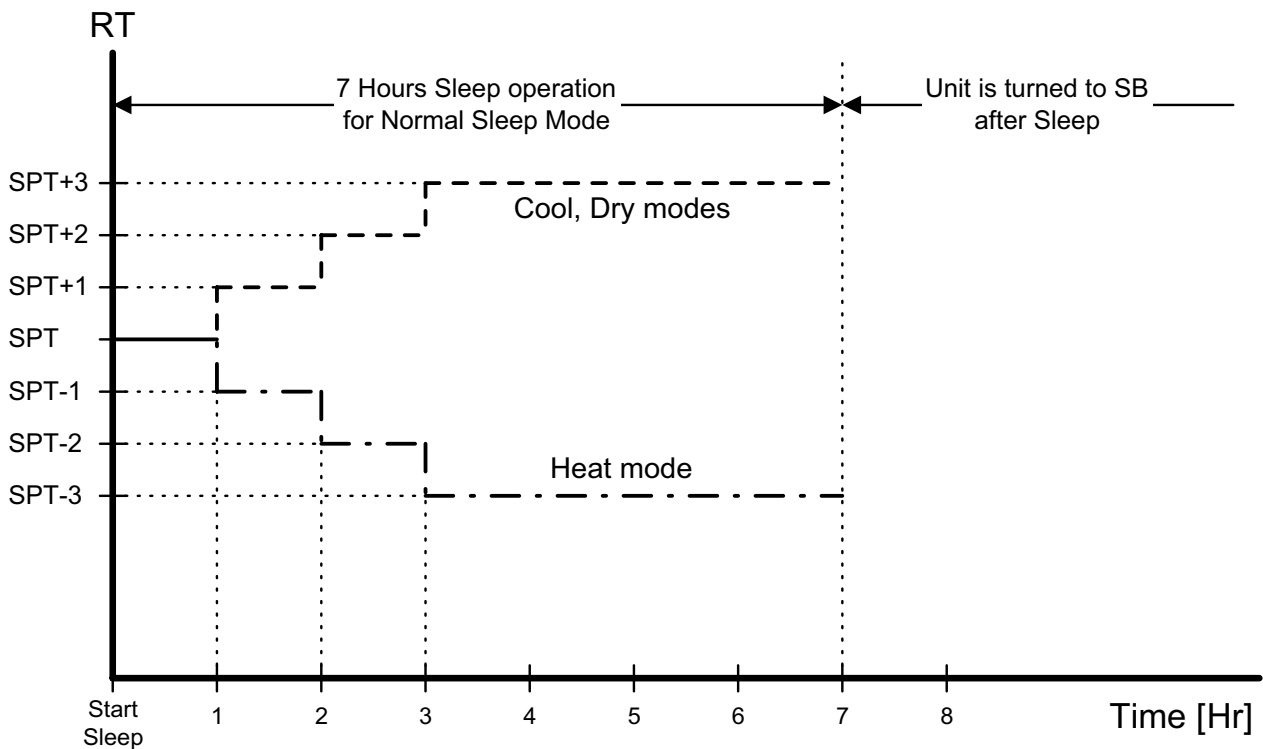

Note: If Off-timer is active, the unit may go to SB before or after 7 hours of sleep operation.

12.11.2 Time adjustment in Sleep Mode

The user can make use of the Off-Timer to extend the Sleep Time from 7 hours to 12 hour (max). The operation of the new "Extended Sleep Mode" is illustrated by the graphs below.

Case 1 is the Standard Sleep Mode, which is the only sleep mode in previous version of MCU. The A/C unit simply works for 7 hours, then goes to SB.

Case 2 is the new Extended Sleep Mode. If an active Off-Timer is set to turn off the A/C between 7-12 hour, relative to the starting of Sleep, the Sleep time is extended.

And, instead of going to SB at the 7th hour, the A/C will work until reaching the Off-time.

Case 3 is an exception to case 2. The Sleep Mode will not be extended to the Off-Time when the Off-Timer is preceded by an On-Timer, which is also between 7-12 hour.

Case 1 : Standard Sleep Mode

Condition : Off-timer is not set or is beyond 12 hour.

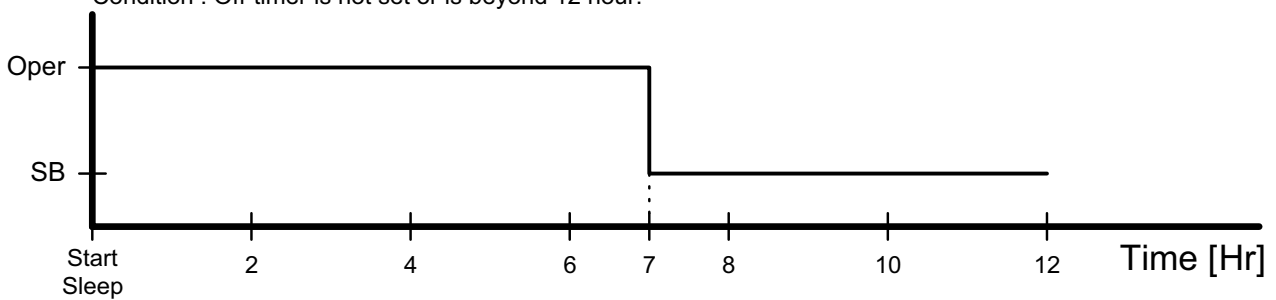

Case 2 : Extended Sleep Mode

Condition : Off-timer is set at 7-12 hour.

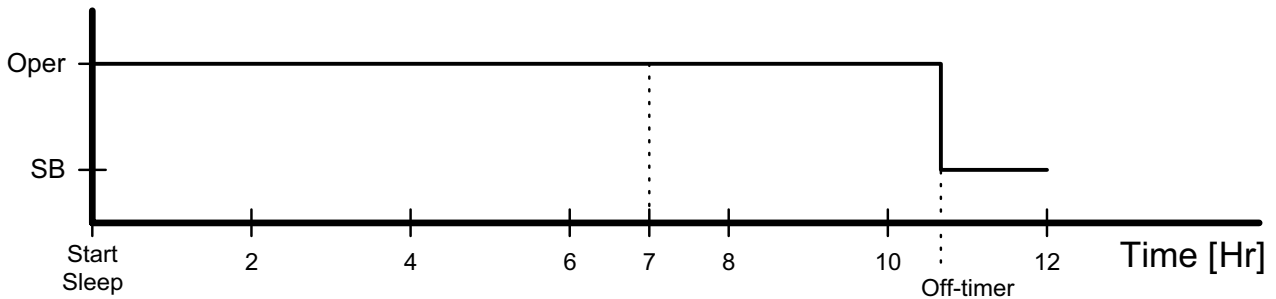

Case 3 : Exception to Case 2

Condition : Off-timer is set at 7-12 hour
On-timer is set at 7-12 hour and before Off-timer

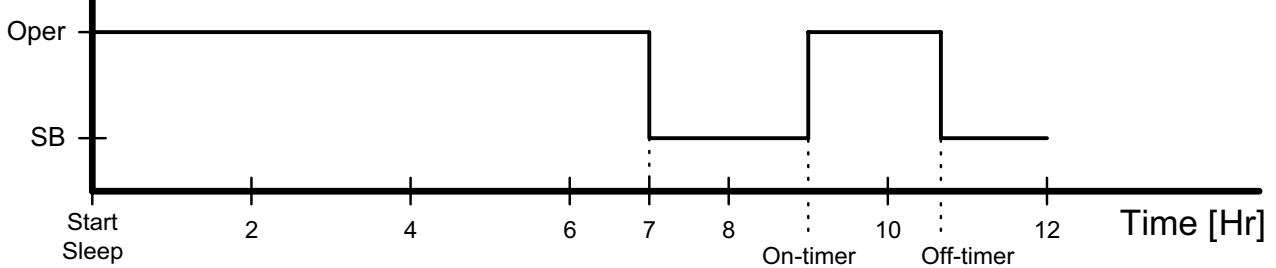

12.12 Controller Self-Test Procedure

12.12.1 By Shorting Test Jumper J1

SELF-TEST FLOW CHART
FOR CONTROLLER (VERSION 4V5 OR HIGHER)

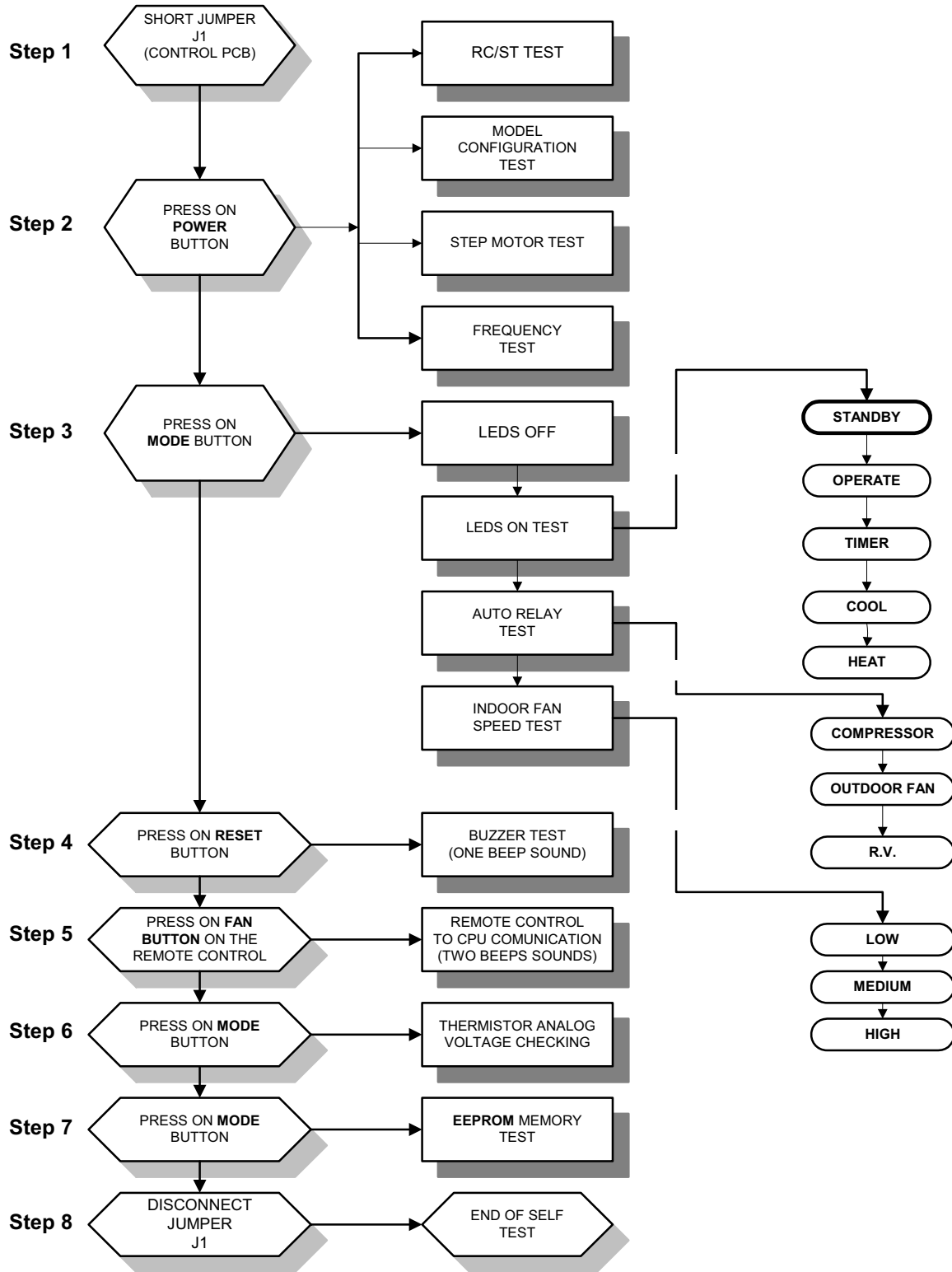

12.12.2 By Remote Control Settings:

- a. 1: TURNING ON THE POWER.
Turn ON the power, make sure that the unit is in operation.
- b. STEP 2 : ENABLE SELF-TEST MODE
 - Use the remote control to send the first settings to display / indoor unit HEAT mode, HIGH IFAN, set temperature to 16 °C, no I-FEEL Sleep or any other timer settings are needed.
 - Cover the IR transmitter components in the remote control so that it will not transmit the signals to the indoor unit display.
 - Use the remote control to send the second settings to display / indoor unit COOL mode, LOW IFAN, no I-FEEL Sleep or any other timer settings.
 - Uncover the remote control IR transmitter and change the temperature settings. If the display/indoor unit receive the settings properly the following steps will start:
- c. STEP 3: MODEL SETTING CONFIRMATION
 - The STAND-BY and COOL LEDS will indicate the operation mode as follows:

OPERATION MODE	STAND-BY LED	COOL LED
ST	ON	OFF
RC	OFF	OFF
SH	OFF	ON
RH	ON	ON

- Testing the Model configuration. Selected by the COMP, STAND-BY, TIMER LEDS and FILTER will indicate the model configuration as follows (the relevant line for this manual is highlighted):

MODEL	COMP	OPERATE LED	TIMER LED	FILTER LED
WNG	ON	OFF	OFF	OFF
WMZ	ON	ON	OFF	ON
WMN4	OFF	OFF	ON	OFF
WMN2/WHX	OFF	ON	OFF	ON
WMN3	OFF	ON	ON	ON

In this term the step motor will turn to HOME POSITION.

d. STEP 4 : AUTO LED WALK TEST.

- All the LEDS will turn OFF.
- All the LEDS will turn ON for 1 second one by one in the following sequence:
 STAND-BY ⇨ OPERATE ⇨ TIMER ⇨ FILTER ⇨ COOL ⇨ HEAT.
- In PRX all the LEDS will turn ON for 1 second one by one in the following sequence : 18 °c ⇨ 20 °c ⇨ 22 °c ⇨ 24 °c ⇨ 26 °c ⇨ 28 °c ⇨ 30 °c ⇨ High IFAN ⇨ Auto IFAN ⇨ Med IFAN ⇨ Low IFAN ⇨ STAND-BY⇨ TIMER ⇨ FILTER ⇨COOL⇨ HEAT.

e. STEP 5: AUTO REALY WALK TEST:

- All relays will energize one by one in the following sequence:
 COMPRESSOR ⇨ OUTDOOR FAN⇨R. V. ⇨ HEATER 1 ⇨ HEATER 2
 ⇨ INDOOR WATER PUMP ⇨ SWING or OUTDOOR WATER PUMP ⇨
 INDOOR FAN: LOW ⇨ MID ⇨ HIGH.
- When the relay walk test is completed, the next test will start automatically.

f. STEP 6: FREQUENCY TESTING:

- If the frequency measuring process fails the COOL LED will turn ON. In order to move to the next step, press ON/OFF button on the remote control.

g. STEP 7: INPUT TEST.

- The test purpose is to check the analog real time indicators (thermistors, LEVEL and clock) according to the table below.

LED Indicator	Condition for LED to be ON
STBY LED	Room thermistor ≠ 25°c
OPER LED	Indoor coil thermistor ≠ 25°c
TIMER LED	Outdoor coil thermistor ≠ 25°c
FILTER LED	Clock
COOL LED	LEVEL 2&3
HEAT LED	LEVEL 4

h. STEP 8: TIMING RESET TEST (WATCH DOG).

- The test purpose is to verify that the CPU rise time after power failure is between 1 to 3 sec, test results are indicated on the LEDS : STAND-BY,OPER, TIMER and FILTER turning ON one by one.
- The results of the test are coded as follows:
 Pass condition:
 1 sec - STAND-BY and OPER are turned ON
 2 sec - STAND-BY, OPER and TIMER are turned ON

Fail condition:

0 sec - STAND-BY is turned ON

3 sec - STAND-BY, OPER, TIMER and FILTER are turned ON

- When the timing reset test is completed, the next test will start automatically.

i. STEP 9: MEMORY TEST (EEPROM)

- The test purpose is to check if the memory is functioning correctly. The test result is reported by using the STAND-BY and FILTER LEDS:

LED Indicator	Condition for LED to be ON
STAND-BY LED	Test passed
FILTER LED	Test failed

AT THIS POINT THE SELF-TEST IS COMPLETED.

In order to terminate Self-Test mode the User can change the unit setting from COOL Mode, LOW FAN to COOL Mode, MED FAN or to wait without using the remote control for 60 sec.

Values of Sensors Temperature VS. Voltage (DC)

Temp. (*C)	Voltage (V)	Temp. (*C)	Voltage (V)	Temp. (*C)	Voltage (V)	Temp. (*C)	Voltage (V)
-20	4.554	2	3.744	24	2.555	46	1.487
-19	4.529	3	3.695	25	2.5	47	1.447
-18	4.502	4	3.646	26	2.445	48	1.409
-17	4.475	5	3.595	27	2.391	49	1.371
-16	4.446	6	3.544	28	2.338	50	1.334
-15	4.417	7	3.492	29	2.284	51	1.298
-14	4.386	8	3.439	30	2.232	52	1.263
-13	4.354	9	3.386	31	2.18	53	1.228
-12	4.322	10	3.332	32	2.128	54	1.195
-11	4.287	11	3.278	33	2.077	55	1.162
-10	4.252	12	3.223	34	2.027	56	1.13
9	4.216	13	3.168	35	1.978	57	1.099
-8	4.178	14	3.113	36	1.929	58	1.069
-7	4.14	15	3.058	37	1.881	59	1.04
-6	4.1	16	3.002	38	1.834	60	1.011
-5	4.059	17	2.946	39	1.798	61	0.983
-4	4.017	18	2.89	40	1.742	62	0.956
-3	3.974	19	2.833	41	1.698	63	0.929
-2	3.93	20	2.777	42	1.654	64	0.904
-1	3.885	21	2.722	43	1.611	65	0.879
0	3.839	22	2.666	44	1.569	66	0.854
1	3.792	23	2.61	45	1.527	67	0.831

12.13 On Unit Indicators and Controls

<p>STAND BY INDICATOR</p>	<p>Lights up when the Air Conditioner is connected to power and ready to receive the R/C commands Blinks continuously in case of any thermistor failure.</p>
<p>OPERATION INDICATOR</p>	<p>Lights up during operation. Blinks for 300 ms, to announce that a R/C infrared signal has been received and stored. Blinks continuously during</p> <ul style="list-style-type: none"> • OCT High Pressure Protection Mode • ICT High Pressure Protection Mode • Deicing in Heating Mode • Water Over Flow in ECC Model
<p>MODE BUTTON (Cool, Heat, SB)</p>	<p>Use to cycle the operation mode of the A/C unit among COOL, HEAT and SB modes, without using the R/C. Every time this switch is pressed, the next operation mode is selected, in this order : SB → Cool Mode → Heat Mode → SB → ... Press this button continuously for 5 sec or more to start the Diagnostic Mode.</p>

12.14 Clock Random Delay From 0 to 2.5 seconds

- 0 = Clock Switch Open
- 1 = Clock Switch close

The Clock is activate according to the following table:

A/C STATE (before clock is changed)	CLOCK STATE (before clock is changed)	CLOCK ACTION (clock is changed)	A/C NEW STATE (after clock is changed)
ON	1	0	OFF
OFF	0	1	ON
OFF by interrupt ⁽¹⁾	1	0	OFF
ON by interrupt ⁽¹⁾	0	1	ON

Notes :

1. Clock can be interrupted by :
 - R/C - POWER ON/OFF Push-button.
 - R/C - TIMER.
 - R/C - SLEEP.
 - A/C - MODE SWITCH.
2. Any change in the CLOCK level during the first 6 sec after the system Reset is ignored.

13. TROUBLESHOOTING

NO	SYMPTON	PROBABLE CAUSE	CORRECTIVE ACTION
1.	The stand-by indicator (red led) on the central control display panel doesn't light up.	There is no correct voltage between the line and neutral terminals on main P.C.B	-If the voltage is low repair power supply. -If there is no voltage repair general wiring. -If there is correct voltage replace main or display P.C.B'S
2.	The operation indicator (green led) on the central control display panel does not light up.	The remote control batteries are discharged	-Replace batteries of the remote control.
3.	The operation indicator (green led) does not light up when starting from unit.	Check main P.C.B and display P.C.B	-Replace P.C.B if necessary.
4.	The indoor fan does not function correctly.	Check the voltage between indoor fan terminals on the main P.C.B	-If there is voltage replace capacitor or motor.
5.	The outdoor fan does not function correctly.	Check the voltage between outdoor fan terminals on the main P.C.B There is voltage between outdoor fan terminals on the outdoor unit. There is no voltage between outdoor fan terminals on the outdoor unit.	-If there is no voltage replace main P.C.B -Replace capacitor or motor. -Check and repair electrical wiring between indoor and outdoor units.
6.	The compressor does not start up.	Check voltage on compressor terminals on the outdoor unit. (with ammeter) Check if there is correct voltage between compressor terminals on the outdoor unit.	-If no voltage replace main P.C.B -If low voltage repair power supply. -If the voltage correct replace capacitor or compressor. -If there is no voltage repair electrical wiring between indoor and outdoor units.
7.	The refrigeration system does not function correctly.	Check for leaks or restrictions. With ammeter. Pressure gauge or surface thermometer.	-Repair refrigeration system and charge refrigerant if necessary.

NO	SYMPTON	PROBABLE CAUSE	CORRECTIVE ACTION
8	No cooling or heating only indoor fan works.	Outdoor fan motor faulty or other fault caused, compressor overload protection cut out.	-Replace P.C.B. -Outdoor fan blocked remove obstructions.
9.	Only indoor fan and compressor working.	Outdoor fan blocked.	-Remove obstructions.
10.	Only indoor fan working.	-Run capacitor of outdoor fan motor faulty. -Windings of outdoor fan are shorted.	-Replace capacitor. -Replace motor.
11.	No cooling or heating takes place, indoor fans working.	-Overload safety device on compressor is cut out (low voltage or high temperature). -Compressor runs capacitor faulty. -Compressor windings are shorted.	-Check for proper voltage, switch off power and try again after one hour. -Replace compressor capacitor. -Replace compressor.
12.	No air supply at indoor unit, compressor operates.	-Indoor fan motor is blocked or turns slowly. -Indoor fan run capacitor faulty. -Motor windings are shorted.	-Check voltage, repair wiring if necessary. -Check fan wheel if it is tight enough on motor shaft, tighten if necessary.
13.	Partial, limited air supply at indoor unit.	Lack of refrigerant (will accompanied by whistling noise) cause ice formation on indoor unit coil in cooling mode.	-charge the unit after localizing leak.
14.	Water accumulates and over flow from indoor unit section.	Drain tube or spout of drain pan clogged.	-Disassemble plastic drain tube from spout of indoor unit drain pan.
15.	Water dripping from outdoor unit base, (in heating mode).	Water drain outlet is clogged.	-Open outdoor unit cover clean out water outlet clean the base inside thoroughly.
16.	Freeze-up of outdoor coil in heating mode, poor heating effect in room, indoor fan operates.	-Faulty outdoor thermistor. -Faulty control cable. -Outdoor temperature is below design conditions. -Outdoor unit air outlet is blocked.	-Replace thermistor. -Repair control cable. -Shut unit off, it cannot work properly. -Remove obstructions.
17.	Unit is in heat mode but operating in cooling.	-Faulty RV coil. -RV coil is ok valve is stuck position.	-Replace RV coil. -Replace the reversing valve.

14. EXPLODED VIEWS AND SPARE PARTS LISTS

14.1 Indoor Unit Alpha 9, 12 SP R22

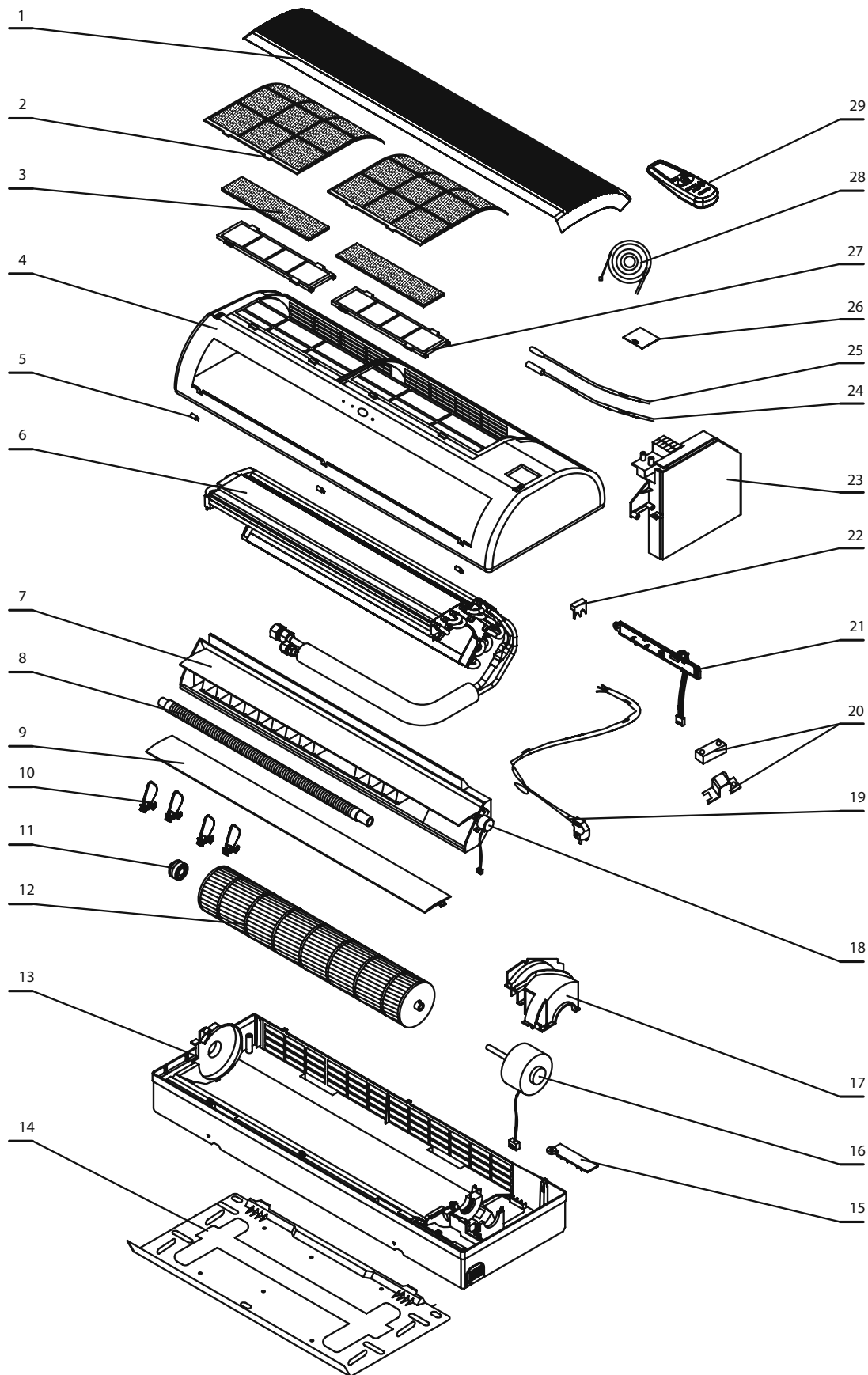

14.2 Indoor Unit Alpha 9 SP R22

No.	Item	Description	Quan.
1	4525979	IOD 7/9 Grille	1
	4527484		1
2	4525989	FILTER	2
4	452700501	Front Frame Assy.	1
	452700509		1
5	4525987	SCREW COVER	3
6	4523860	Coil ASSY	1
7	4525982	AIR OUTLET FRAME	1
8	4523693	DRAIN HOSE	1
9	4525991	LOUVER	1
10	4525992	Vertical flapA	8
10	4525993	Vertical flapB	2
11	4523526	Bearing assy fan	1
12	453264200	Impeller Fan	1
13	4526659	REAR PANEL ASSY	1
14	464220008	Mount Bracket./Low Cost ALPHA 9	1
15	4526000	TUBE CLIP	1
16	4523534R	MOTOR	1
17	4525998	MOTEOR COVER	1
18	4523507	Step motor	1
20	4525988	CABLE LOCKER	1
21	467300003R	Display Board Assy./ WME7/9/12(WME Controller,16pin)	1
22	4516263	SENSOR BASE	1
23	467300051R	Controller / Omega	1
24	438082	Thermistor Indoor coil BLACK	1
25	4519813	Thermistor room	1
26	453027000	Terminal Cover	1
28	4520416	Defrost cable EXPORT UNITS	1
29	412040R	Remote controller RC5-RC 975-630-00	1

14.3 Indoor Unit Alpha 12 SP R22

No.	Item	Description	Quan.
1	4527501	IOD 12 Grille	1
	4527502		1
2	4527507	Filter	2
4	452766801	Front Frame Assy.	1
	452766805		1
5	4525987	SCREW COVER	3
6	462350047	Evaporator Assy./CON 12 R22	1
7	4527506	Air Outlet	1
8	4523693	DRAIN HOSE	1
9	4527509	Horizontal Flap	1
10	4525992	VER. FLAP A	9
10	4527510	Vertical Flap B	3
11	4523526	Bearing assy fan	1
12	4527111	FAN ASSY PLASTIC	1
13	4527186	IOD-12 REAR PANEL ASSY	1
14	464220007	Mount Bracket./Low Cost ALPHA 12	1
15	4527512	Tube Clip	1
16	4527112R	Motor Compact 12	1
17	4525998	MOTEOR COVER	1
18	4523507	Step motor	1
20	4525988	CABLE LOCKER	1
21	467300003R	Display Board Assy./ WME7/9/12(WME Controller,16pin)	1
22	4516263	SENSOR BASE	1
23	467300051R	Controller / Omega	1
24	438082	Thermistor Indoor coil BLACK	1
25	4519813	Thermistor room	1
26	453027000	Terminal Cover	1
28	4520416	Defrost cable EXPORT UNITS	1
29	412040R	Remote controller RC5-RC 975-630-00	1

14.4 Outdoor Unit: CSP 9, 12 RC R22

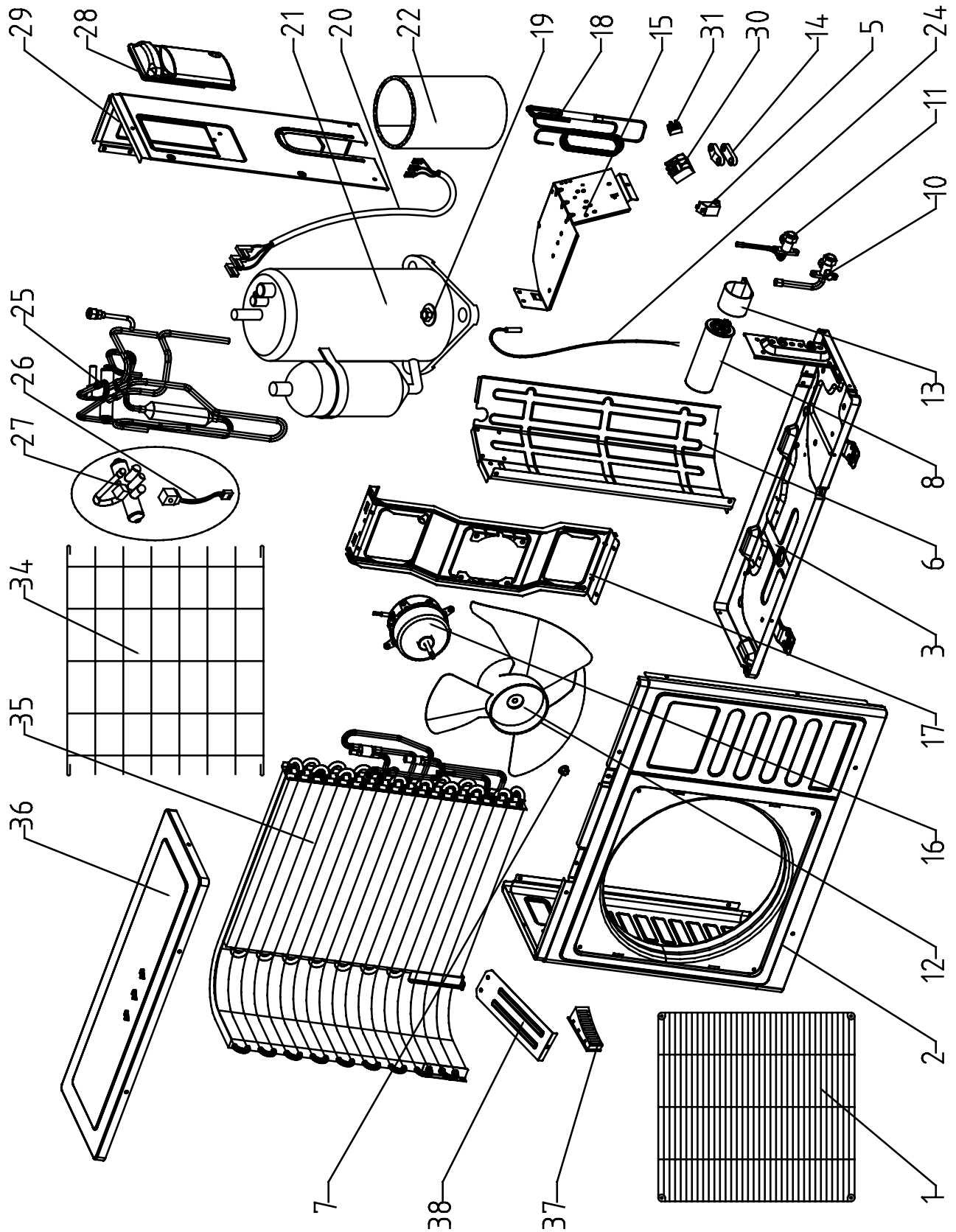

14.5 Outdoor Unit CSP 9 RC R22

No.	Item	Description	Quan.
1	4526481	CON Outdoor Grille	1
2	464660013	Front panel Painting assy/CON 9/12	1
3	464600056	Base Plate Painting Assy./CON SP 9 R22	1
5	455000108	Double patch Capacitor for fan motor 2uF	1
6	4526141	PARTITION PLATE	1
7	4510679	Nut M6 GB6187-86	1
8	455000401	Compressor Capacitor 30uF (CBB65)	1
10	4523587	GAS VALVE	1
11	4523533	Liquid Valve	1
12	4523707	AXIAL FAN	1
13	4518839	Comp. Capacitor Clip	1
14	204107	Cable clip Nylon	1
15	453044500	Pedestal/Control	1
16	466100017R	Metal Motor 20W 900rpm/Outdoor Unit	1
17	4526146	MOTOR SUPPORT ASSY	1
18	4523913	Capillary assy	1
19	201019	Nut M8	3
20	391498	Wire assy	1
21	452982000	Compressor assy PH170X1C-4DZDE3	1
22	469100003	Insulation Felt/ Compressor	1
24	4516637	Out sensor Black	1
25	4526875	4-W vavle welding assy	1
26	4514005	4-W valve coil	1
27	224213	4-W valve	1
28	4526668	R lifter	1
29	4526669	SIDE PANEL PAINTING	1
30	4514588	5 Poles terminal block	1
31	236179	2 Poles terminal block	1
34	464800008	Guard Net Painting Assy. /CON	1
35	4526651	Cond. Assy	1
36	4526675	TOP COVER PAINTING	1
37	436358	L. lifter	1
38	4526143	LINKER OF MOTOR SUPPORT ASSY	1

14.6 Outdoor Unit: CSP 12 RC R22

No.	Item	Description	Quan.
1	4526481	CON Outdoor Grille	1
2	464660013	Front panel Painting assy/CON 9/12	1
3	464600040	Base Painting assy/ CON 12 R410A	1
5	455000108	Double patch Capacitor for fan motor 2uF	1
6	464160019	Partition plate/CON 9/12	1
7	4510679	Nut M6 GB6187-86	1
8	455000502	Compressor Capacitor With Screw 25uF (CBB65)	1
10	461010021	Gas Valve 1/2" R22	1
11	461000013	Liquid Valve 1/4" R22	1
12	4523707	AXIAL FAN	1
14	204107	Cable clip Nylon	1
15	464180011	Capacitor Support/CON 9/12	1
16	466100017R	Metal Motor 20W 900rpm/Outdoor Unit	1
17	453045000	Motor support	1
18	463600030	Capillary Assy. (OD2.6xID1.6x800+450)	1
19	201019	Nut M8	3
20	391498	Wire assy	1
21	460030002R	Compressor Assy/ SANYO C-RV212H51BA	1
22	469100003	Insulation Felt/ Compressor	1
24	4516637	Out sensor Black	1
25	461600038	4-Way Valve Assy./CON12 R22	1
26	4514005	4-W valve coil	1
27	224213	4-W valve	1
28	4526668	R lifter	1
29	464630010	Side Plate Painting Assy./Right/CON 9/12	1
30	4514588	5 Poles terminal block	1
31	236179	2 Poles terminal block	1
34	464800008	Guard Net Painting Assy. /CON	1
35	462300046	Condenser Assy/CON 12 R22	1
36	4526675	TOP COVER PAINTING	1
37	436358	L. lifter	1
38	4526143	LINKER OF MOTOR SUPPORT ASSY	1

14.7 Indoor Unit: Alpha 9, 12 SP R410A EU

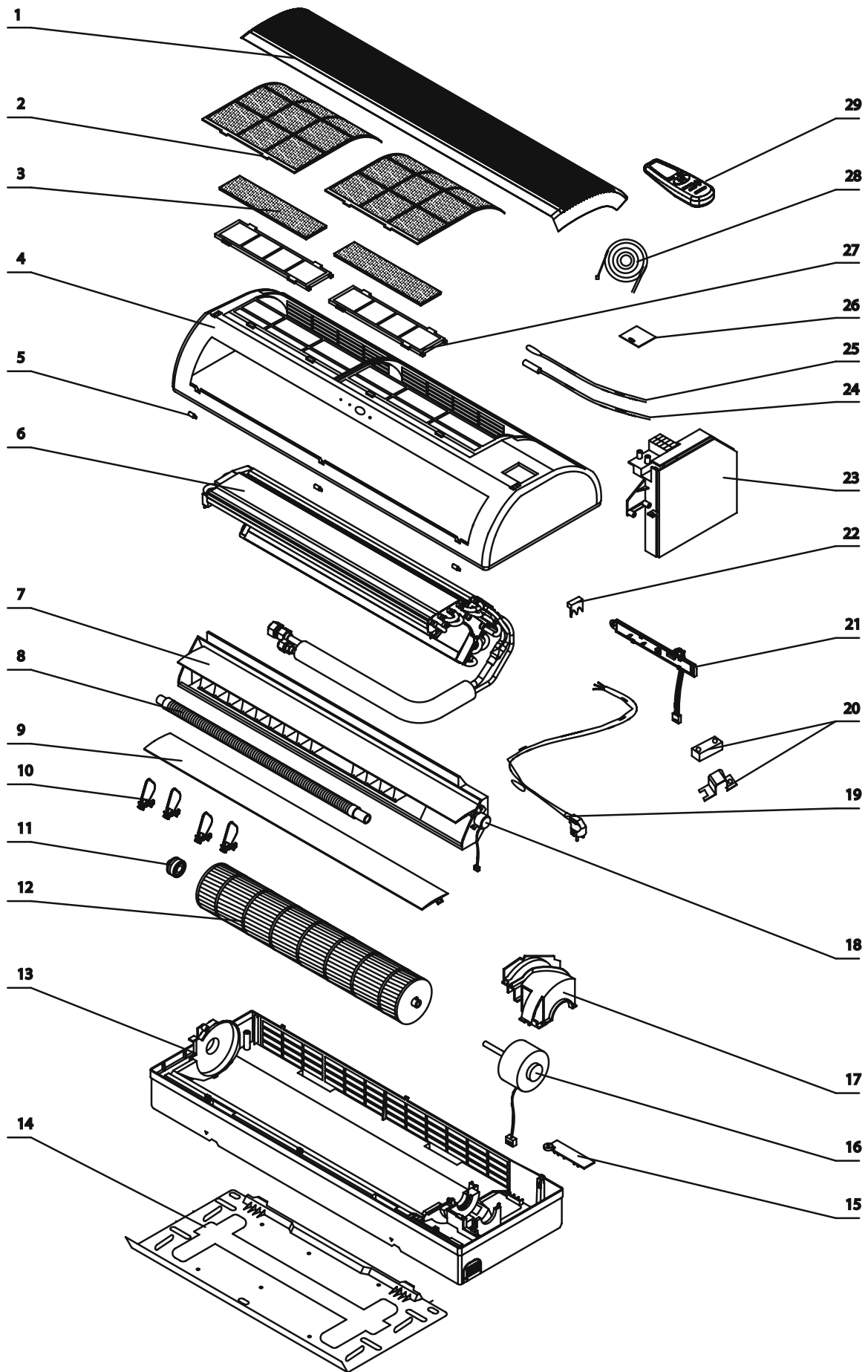

14.8 Indoor Unit Alpha 9, SP R410A EU

No.	P/N	Description	Quan.
1	4525979	IOD 7/9 Grille A	1
	4527484	IOD 7/9 Grille B	1
2	4525989	FILTER	2
4	452700501	AIRWELL Front Frame Assy.	1
	452700509	ELECTRA Front Frame Assy.	1
5	4525987	SCREW COVER	3
6	462350045	Evaporator Assy./Low Cost ALPHA 9 R410A For EU	1
7	452784400	IOD-7,9 Air Outlet Assy. (no wire)	1
8	4523693	DRAIN HOSE	1
9	4525991	LOUVER	1
10	4525992	VER. FLAP A	8
10	4525993	VER. FLAP B	2
11	4523526	BERAING ASSY FAN	1
12	453264200	Impeller Fan	1
13	4526659	REAR PANEL ASSY	1
14	464220008	Mount Bracket./Low Cost ALPHA 9	1
15	4526000	TUBE CLIP	1
16	4527112R	Motor Compact 12	1
17	4525998	MOTEOR COVER	1
18	4523507	Step motor	1
20	4525988	CABLE LOCKER	1
21	467300003R	Display Board Assy./ WME7/9/12(WME Controller,16pin)	1
22	4516263	SENSOR BASE	1
23	467300051R	Controller / Omega	1
24	438082	Thermistor Indoor coil BLACK	1
25	4519813	Thermistor room	1
26	453027000	Terminal Cover	1
28	4520416	Defrost cable EXPORT UNITS	1
29	412040R	Remote controller RC5-RC 975-630-00	1

14.9 Indoor Unit Alpha 12, SP R410A EU

NO.	P/N	Description	Quan.
1	4527502	IOD12 Grille B	1
	465100014	Grill /Alpha 12 FAGOR	1
	4527501	IOD 12 Grille A	1
2	4527507	Filter	2
	453082900	Filter for DELTA 12	2
4	452766805	ELECTRA Front Frame Assy.	1
	465720128	Front Frame Assy./Delta F 12	1
	452766801	AIRWELL Front Frame Assy.	1
5	4525987	SCREW COVER	3
6	470680012	Evaporator List/Low Cost ALPHA 12 R410A For EU	1
7	452784401	IOD-12 Air Outlet Assy. (no wire)	1
	4527506	Air Outlet	1
8	4523693	DRAIN HOSE	1
9	4527509	Horizontal Flap	1
10	4525992	VER. FLAP A	9
10	4527510	Vertical Flap B	3
11	4523526	BERAING ASSY FAN	1
12	4527111	FAN ASSY PLASTIC	1
13	4527186	IOD-12 REAR PANEL ASSY	1
14	464220007	Mount Bracket./Low Cost ALPHA 12	1
15	4527512	Tube Clip	1
16	4527112R	Motor Compact 12	1
17	4525998	MOTEOR COVER	1
18	4523507	Step motor	1
20	4525988	CABLE LOCKER	1
21	467300003R	Display Board Assy./ WME7/9/12(WME Controller,16pin)	1
	467300041R	Display Board/ Delta7/9/12 fix RPM	1
22	4516263	SENSOR BASE	1
23	467300051R	Controller / Omega	1
	467300049R	Controller / Delta7/9/12 fix RPM	1
24	438082	Thermistor Indoor coil BLACK	1
25	4519813	Thermistor room	1
26	453027000	Terminal Cover	1
28	4520416	Defrost cable EXPORT UNITS	1
29	412040R	Remote controller RC5-RC 975-630-00	1
32	465440009	Frame Left Crank	1
32	465440010	Frame Right Crank	1

14.10 Outdoor Unit: CSP 9, 12 RC R410A EU

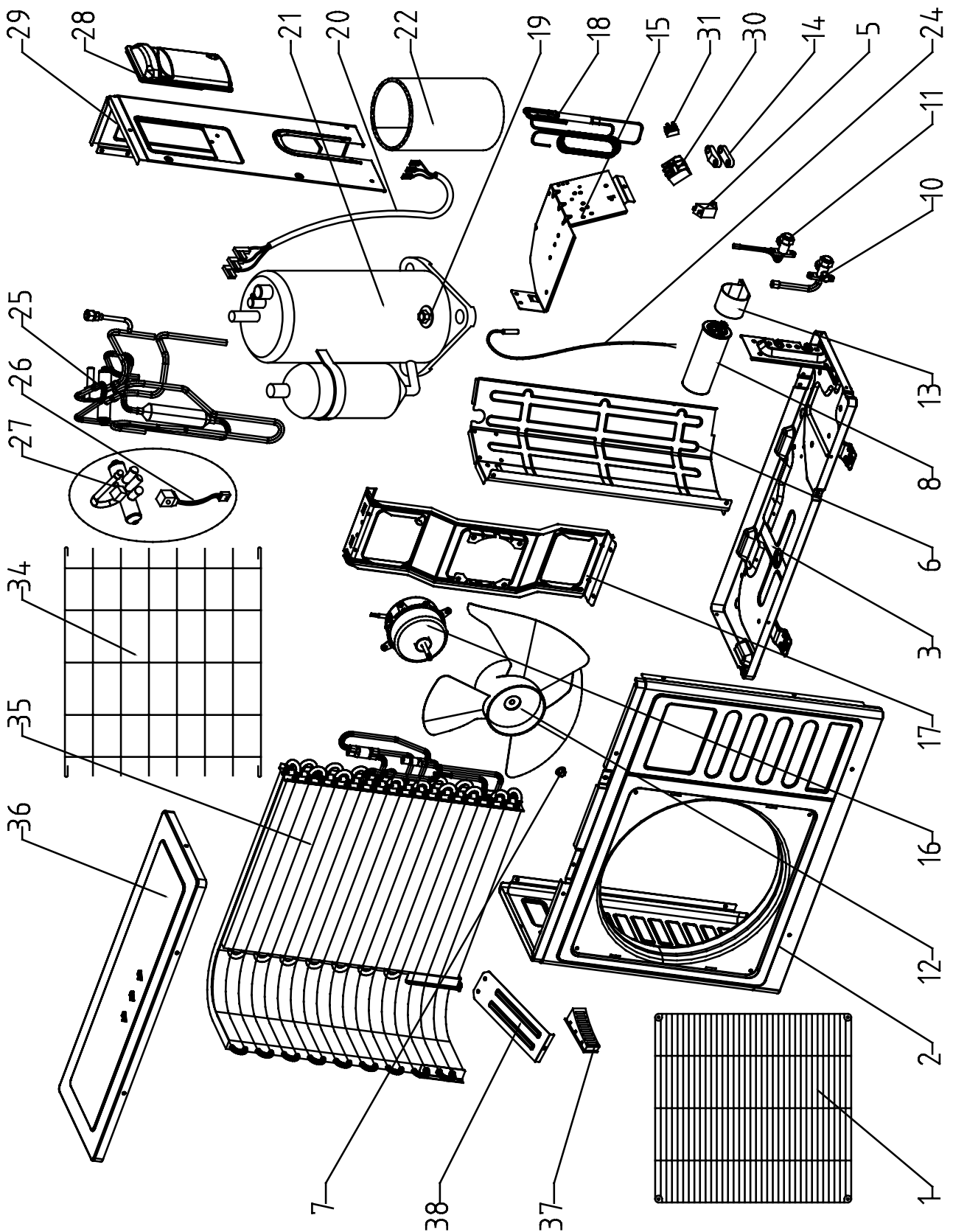

14.11 Outdoor Unit: CSP 9, RC R410A EU

NO.	P/N	Description	Quan.
1	4526481	CON Outdoor Grille	1
2	464660013	Front panel Painting assy/CON 9/12	1
3	464600046	Base Plate Painting assy/CON 9 R410A	1
5	455000108	Double patch Capacitor for fan motor 2uF	1
6	464160019	Partition plate/CON 9/12	1
7	4510679	Nut M6 GB6187-86	1
8	455000503	Compressor Capacitor With Screw 30uF (CBB65)	1
10	461010020	Gas Valve 3/8" R410A	1
11	461000011	Liquid Valve 1/4" R410A	1
12	4523707	AXIAL FAN	1
14	204107	Cable clip Nylon	1
15	464180011	Capacitor Support/CON 9/12	1
16	466100017R	Metal Motor 20W 900rpm/Outdoor Unit	1
17	453045000	Motor support	1
18	463600026	Capillary Assy. 2.6x1.4x1200	1
19	201019	Nut M8	3
20	391498	Wire assy	1
21	460090002R	Compressor Assy./SANYO C-1RV107H1C	1
22	469100003	Insulation Felt/ Compressor	1
24	4516637	Out sensor Black	1
25	461600034	4-Way Valve Assy./CON 9 R410A	1
26	4520071	4-W valve coil for R410A	1
27	4518951	4-W valve SHF-4H for R410A	1
28	4526668	R lifter	1
29	464630010	Side Plate Painting Assy./Right/CON 9/12	1
30	4514588	5 Poles terminal block	1
31	236179	2 Poles terminal block	1
34	464800008	Guard Net Painting Assy. /CON	1
35	462300038	Condenser Assy/CON 9	1
36	4526675	TOP COVER PAINTING	1
37	436358	L. lifter	1
38	4526143	LINKER OF MOTOR SUPPORT ASSY	1

14.12 Outdoor Unit: CSP 12 RC R410A EU

NO.	P/N	Description	Quan.
1	4526481	CON Outdoor Grille	1
2	464660013	Front panel Painting assy/CON 9/12	1
3	464600040	Base Painting assy/ CON 12 R410A	1
5	455000108	Double patch Capacitor for fan motor 2uF	1
6	464160019	Partition plate/CON 9/12	1
7	4510679	Nut M6 GB6187-86	1
8	455000502	Compressor Capacitor With Screw 25uF (CBB65)	1
10	461010020	Gas Valve 3/8" R410A	1
11	461000011	Liquid Valve 1/4" R410A	1
12	4523707	AXIAL FAN	1
14	204107	Cable clip Nylon	1
15	464180011	Capacitor Support/CON 9/12	1
16	466100017R	Metal Motor 20W 900rpm/Outdoor Unit	1
17	453045000	Motor support	1
18	463600028	Capillary Assy.	1
19	201019	Nut M8	3
20	391498	Wire assy	1
21	460090000R	Compressor Assy./SANYO C-RV133H1D	1
22	469100003	Insulation Felt/ Compressor	1
24	4516637	Out sensor Black	1
25	461600031	4-Way Valve System Assy./ CON 12 R410A	1
26	4520071	4-W valve coil for R410A	1
27	4518951	4-W valve SHF-4H for R410A	1
28	4526668	R lifter	1
29	464630010	Side Plate Painting Assy./Right/CON 9/12	1
30	4514588	5 Poles terminal block	1
31	236179	2 Poles terminal block	1
34	464800008	Guard Net Painting Assy. /CON	1
35	462300039	Condenser Assy/CON 12 For EU	1
36	4526675	TOP COVER PAINTING	1
37	436358	L. lifter	1
38	4526143	LINKER OF MOTOR SUPPORT ASSY	1

14.13 Outdoor Unit: CSP 9, 12 ST R410A EU

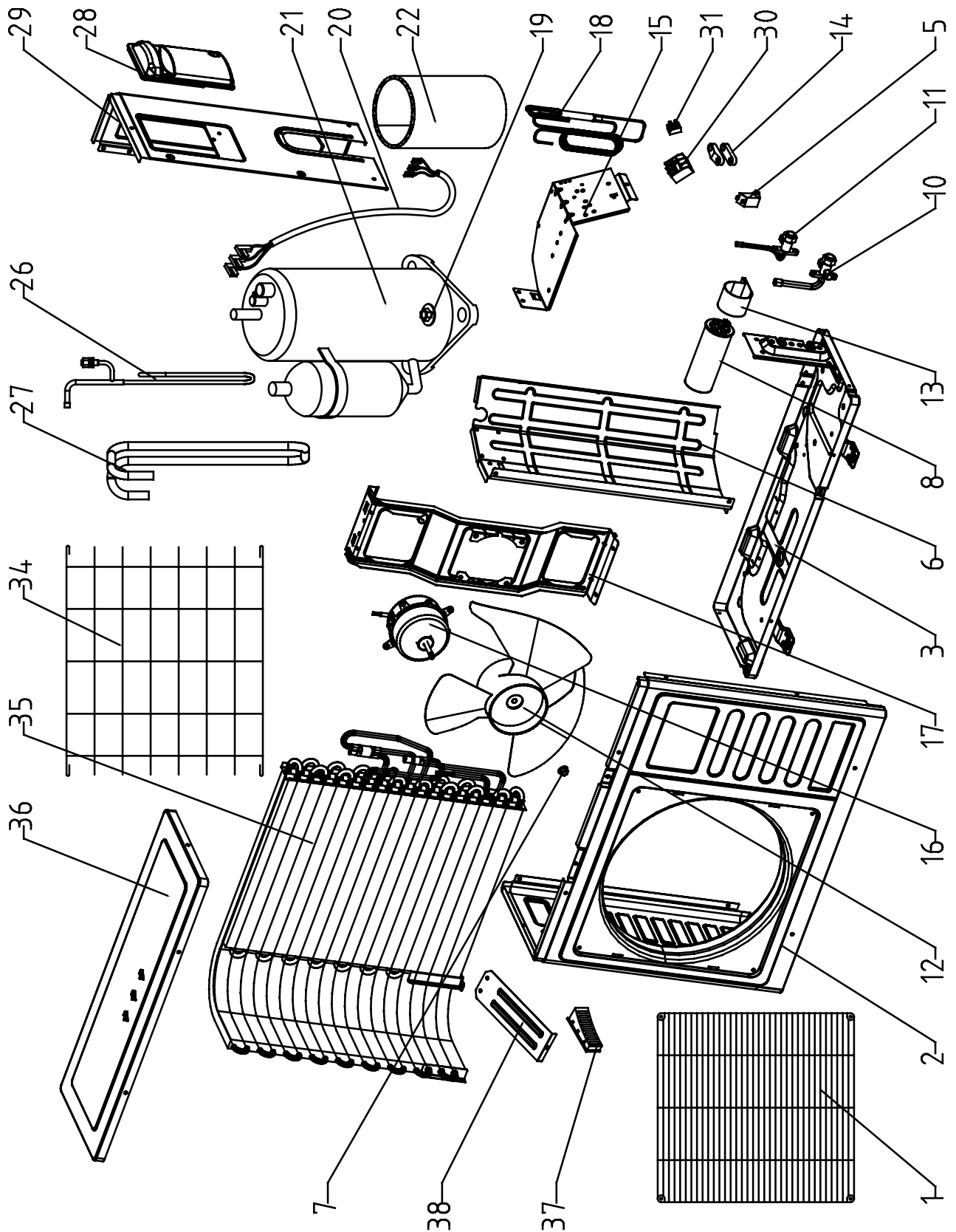

14.14 Outdoor Unit: CSP 9 ST R410A EU

NO.	P/N	Description	Quan.
1	4526481	CON Outdoor Grille	1
2	464660013	Front panel Painting assy/CON 9/12	1
3	464600046	Base Plate Painting assy/CON 9 R410A	1
5	455000108	Double patch Capacitor for fan motor 2uF	1
6	464160019	Partition plate/CON 9/12	1
7	4510679	Nut M6 GB6187-86	1
8	455000503	Compressor Capacitor With Screw 30uF (CBB65)	1
10	461010020	Gas Valve 3/8" R410A	1
11	461000011	Liquid Valve 1/4" R410A	1
12	4523707	AXIAL FAN	1
14	204107	Cable clip Nylon	1
15	464180011	Capacitor Support/CON 9/12	1
16	466100017R	Metal Motor 20W 900rpm/Outdoor Unit	1
17	453045000	Motor support	1
18	463600026	Capillary Assy. 2.6x1.4x1200	1
19	201019	Nut M8	3
20	391498	Wire assy	1
21	460090002R	Compressor Assy./SANYO C-1RV107H1C	1
22	469100003	Insulation Felt/ Compressor	1
26	463300375	Discharge Pipe TP2M 7.94*0.8/CON 9 ST R410A	1
27	463300377	Scution Pipe TP2M 9.53*0.8/CON 9 ST R410A	1
28	4526668	R lifter	1
29	464630010	Side Plate Painting Assy./Right/CON 9/12	1
31	236179	2 2 Poles terminal block	1
34	464800008	Guard Net Painting Assy. /CON	1
35	462300042	Condenser Assy/CON 9 ST	1
36	4526675	TOP COVER PAINTING	1
37	436358	L. lifter	1
38	4526143	LINKER OF MOTOR SUPPORT ASSY	1

14.15 Outdoor Unit: CSP 12 ST R410A EU

No.	P/N	Description	Quan.
1	4526481	CON Outdoor Grille	1
2	464660013	Front panel Painting assy/CON 9/12	1
3	464600040	Base Painting assy/ CON 12 R410A	1
5	455000108	Double patch Capacitor for fan motor 2uF	1
6	464160019	Partition plate/CON 9/12	1
7	4510679	Nut M6 GB6187-86	1
8	455000502	Compressor Capacitor With Screw 25uF (CBB65)	1
10	461010020	Gas Valve 3/8" R410A	1
11	461000011	Liquid Valve 1/4" R410A	1
12	4523707	AXIAL FAN	1
14	204107	Cable clip Nylon	1
15	464180011	Capacitor Support/CON 9/12	1
16	466100017R	Metal Motor 20W 900rpm/Outdoor Unit	1
17	453045000	Motor support	1
18	463600028	Capillary Assy.	1
19	201019	Nut M8	3
20	391498	Wire assy	1
21	460090000R	Compressor Assy./SANYO C-RV133H1D	1
22	469100003	Insulation Felt/ Compressor	1
26	463300376	Discharge Pipe TP2M 7.94*0.8/CON 12 ST R410A	1
27	463300378	Scution Pipe TP2M 9.53*0.8/CON 12 ST R410A	1
28	4526668	R lifter	1
29	464630010	Side Plate Painting Assy./Right/CON 9/12	1
30	4514588	5 Poles terminal block	1
34	464800008	Guard Net Painting Assy. /CON	1
35	462300043	Condenser Assy/CON 12 ST	1
36	4526675	TOP COVER PAINTING	1
37	436358	L. lifter	1
38	4526143	LINKER OF MOTOR SUPPORT ASSY	1

14.16 Indoor Unit: Alpha SP 9, 12 R410A ISR

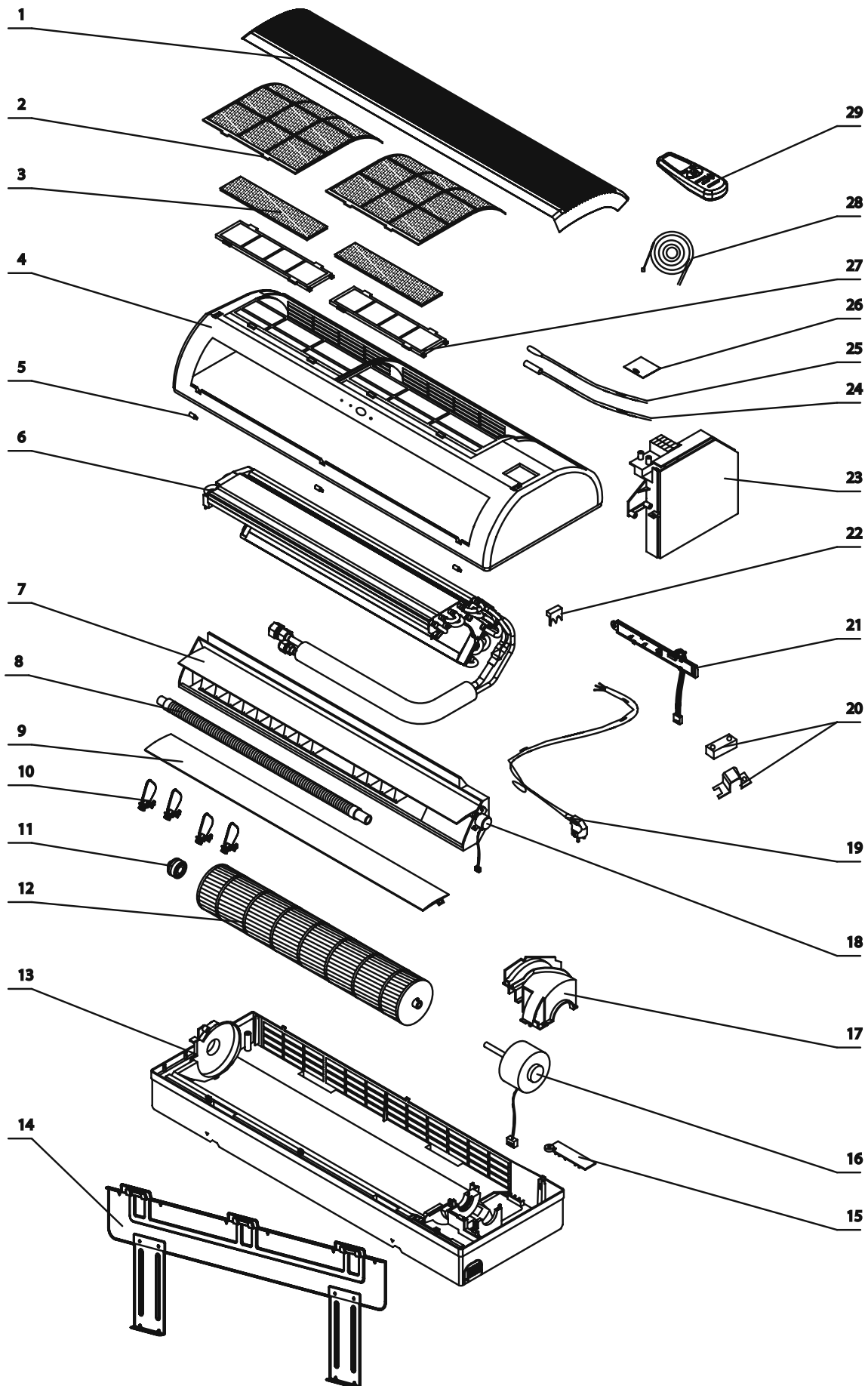

14.17 Indoor Unit: Alpha SP 9 R410A ISR A1

No.	Item	Description	Quan.
1	465100013	Grill /Alpha 7,9 F	1
	4525979	IOD 7/9 Grille A	1
2	453036500	Filter for DELTA 7/9	2
	4525989	FILTER	2
4	465720127	Front Frame Assy./Delta F 9	1
	465020076	Silk-Screen Front Frame Assy./ALPHA SP 9 MEGA AIR R410A	1
	465020080	Silk-Screen Front Frame Assy./ALPHA SP 9 JETPOINT AIR R410A	1
5	4525987	SCREW COVER	3
6	462350045	Evaporator Assy./Low Cost ALPHA 9 R410A For EU	1
7	4525982	AIR OUTLET FRAME	1
8	4523693	DRAIN HOSE	1
9	4525991	LOUVER	1
10	4525992	VER. FLAP A	8
10	4525993	VER. FLAP B	2
11	4523526	BERAING ASSY FAN	1
12	453264200	Impeller Fan	1
13	4526659	REAR PANEL ASSY	1
14	464220008	Mount Bracket./Low Cost ALPHA 9	1
15	4526000	TUBE CLIP	1
16	4527112R	Motor Compact 12	1
17	4525998	MOTEOR COVER	1
18	4523507	Step motor	1
20	4525988	CABLE LOCKER	1
21	467300041R	Display Board/ Delta7/9/12 fix RPM	1
	467300003R	Display Board Assy./ WME7/9/12(WME Controller,16pin)	1
22	4516263	SENSOR BASE	1
23	467300049R	Controller / Delta7/9/12 fix RPM	1
	467300051R	Controller / Omega	1
24	438082	Thermistor Indoor coil BLACK	1
25	4519813	Thermistor room	1
26	453027000	Terminal Cover	1
28	4520416	Terminal Cover	1
29	412040R	Remote controller RC5-RC 975-630-00	1
32	465440009	Frame Left Crank	1
32	465440010	Frame Right Crank	1

14.18 Indoor Unit: Alpha SP 9 R410A ISR A2

No.	Item Code	Item Description	Quantity
1	4525979	IOD 7/9 Grille A	1
2	4525989	FILTER	2
4	4527003	ELECTRA Front Frame Assy.	1
4	452700501	AIRWELL Front Frame Assy.	1
4	465020076	Silk-Screen Front Frame Assy./ALPHA SP 9	1
4	465020080	Silk-Screen Front Frame Assy./ALPHA SP 9	1
5	4525987	SCREW COVER	3
6	4523860	Coil ASSY	1
7	452784400	IOD-7,9 Air outlet Assy	1
8	4523693	DRAIN HOSE	1
9	4525991	LOUVER	1
10	4525992	VER. FLAP A	9
10	4525993	VER. FLAP B	3
11	4523526	BERAING ASSY FAN	1
12	453264200	Impeller Fan	1
13	4526659	REAR PANEL ASSY	1
14	464220008	Mount Bracket./Low Cost ALPHA 9	1
15	4526000	TUBE CLIP	1
16	4527112R	Motor Compact 12	1
17	4525998	MOTEOR COVER	1
18	4523507	Step motor	1
19	455013401R	ISR ISRPowerCord/3G/1.0/2100(187)	1
20	4525988	CABLE LOCKER	1
21	467300003R	Display Board Assy./ WME7/9/12(WME Contr	1
22	4516263	SENSOR BASE	1
23	467300198R	Controller/Delta 7/9/12 S/W:10V14	1
24	438082	Thermistor Indoor	1
25	467400024	Indoor Air Inlet Temperature Se	1
26	453027000	Terminal Cover	1
28	4520416	Defrost cable EXPORT UNITS	1
29	412040R	Remote controller RC5-RC	1

14.19 Indoor Unit: Alpha SP 9 R410A ISR A2 (Omega)

No.	Item Code	Item Description	Quantity
1	465100008	Grill/ ALPHA7/9 Flat-Type	1
2	453036500	Filter for DELTA 7/9	2
4	465720065	Front Frame Assy./OMEGA 9	1
5	4525987	SCREW COVER	3
6	4523860	Coil ASSY	1
7	452784400	IOD-7,9 Air outlet Assy	1
8	4523693	DRAIN HOSE	1
9	4525991	LOUVER	1
10	4525992	VER. FLAP A	8
10	4525993	VER. FLAP B	2
11	4523526	BERAING ASSY FAN	1
12	453264200	Impeller Fan	1
13	4526659	REAR PANEL ASSY	1
14	464220008	Mount Bracket./Low Cost ALPHA 9	1
15	4526000	TUBE CLIP	1
16	4527112R	Motor Compact 12	1
17	4525998	MOTEOR COVER	1
18	4523507	Step motor	1
19	455013401R	ISR ISRPowerCord/3G/1.0/2100(187)	1
20	4525988	CABLE LOCKER	1
21	453089600R	Display assy. for DELTA EHK:936A034-00	1
22	4516263	SENSOR BASE	1
23	467300198R	Controller/Delta 7/9/12 S/W:10V14	1
24	438082	Thermistor Indoor	1
25	4519813	Thermistor room	1
26	465340008	Terminal Cover/ ALPHA7/9 Flat-Type	1
28	4520416	Defrost cable EXPORT UNITS	1
29	438600R	Remote controller RC3-RC 973-600-00	1
32	453100500	Grill L axis	1
32	453100600	Grill R axis	1
33	465340063	Display Cover/ omega7/9 ELCO	1

14.20 Indoor Unit: Alpha SP 12 R410A ISR A1

No.	Item	Description	Quan.
1	465100014	Grill /Alpha 12F	1
	4527501	IOD 12 Grille A	1
2	453082900	Filter for DELTA 12	2
	4527507	Filter	2
4	465720128	Front Frame Assy./Delta F 12	1
	465020077	Silk-Screen Front Frame Assy./ALPHA SP 12 MEGA AIR R410A	1
	465020081	Silk-Screen Front Frame Assy./ALPHA SP 12 JETPOINT AIR R410A	1
5	4525987	SCREW COVER/HIPS/Low Cost ALPHA 9/12	3
6	470680012	Evaporator List/Low Cost ALPHA 12 R410A For EU	1
7	4527506	Air outlet	1
8	4523693	Drain hose	1
9	4527509	Horizontal flap	1
10	4525992	Vertical flapA	9
10	4527510	Vertical flapB	3
11	4523526	BERAING ASSY FAN	1
12	4527111	FAN ASSY PLASTIC	1
13	4527186	IOD-12 REAR PANEL ASSY	1
14	464220007	Mount Bracket./Low Cost ALPHA 12	1
15	4527512	Tube Clip	1
16	4527112R	Motor Compact 12	1
17	4525998	MOTEOR COVER	1
18	4523507	STEP MOTOR	1
20	4525988	CABLE LOCKER	1
21	467300041R	Display Board/ Delta7/9/12 fix RPM	1
	467300003R	Display Board Assy./ WME7/9/12(WME Controller,16pin)	1
22	4516263	SENSOR BASE	1
23	467300049R	Controller / Delta7/9/12 fix RPM	1
	467300051R	Controller / Omega	1
24	438082	Thermistor Indoor coil BLACK	1
25	4519813	Thermistor room	1
26	453027000	Terminal Cover/Lex-18	1
28	4520416	Defrost cable	1
29	412040R	Remote controller RC5-RC 975-630-00	1
32	465440009	Frame Left Crank	1
32	465440010	Frame Right Crank	1

14.21 Indoor Unit: Alpha SP 12 R410A ISR A2

No.	Item Code	Item Description	Quantity
1	4527501	IOD12 Grille A	1
2	4527507	Filter	2
4	452766800	ELECTRA Front Frame Assy.	1
4	452766801	AIRWELL Front Frame Assy.	1
5	4525987	SCREW COVER	3
6	453058200	Evap. System Assy./Alfa12	1
7	452784401	IOD-12 Air Outlet Assy. (no wire)	1
8	4523693	DRAIN HOSE	1
9	4527509	Horizontal Flap	1
10	4525992	VER. FLAP A	9
10	4527510	Vertical Flap B	3
11	4523526	BERAING ASSY FAN	1
12	4527111	FAN ASSY PLASTIC	1
13	4527186	IOD-12 REAR PANEL ASSY	1
14	464220007	Mount Bracket./Low Cost ALPHA 12	1
15	4526000	Tube Clip	1
16	4527112R	Motor Compact 12	1
17	4525998	MOTEOR COVER	1
18	4523507	Step motor	1
19	455013401R	ISR ISRPowCord/3G/1.0/2100(187)	1
20	4525988	CABLE LOCKER	1
21	467300003R	Display Board Assy./ WME7/9/12(WME Contr	1
22	4516263	SENSOR BASE	1
23	467300198R	Controller/Delta 7/9/12 S/W:10V14	1
24	467400024	Thermistor Indoor	1
25	4519813	Thermistor room	1
26	453027000	Terminal Cover	1
28	4520416	Defrost cable EXPORT UNITS	1
29	467240007	Remote controller Assy.with batteries.	1

14.22 Indoor Unit: Alpha SP 12 R410A ISR A2 (Omega)

No.	Item Code	Item Description	Quantity
1	465100009	Grill/ ALPHA12 Flat-Type	1
2	453082900	Filter for DELTA 12	2
4	465720066	Front Frame Assy./OMEGA 12	1
5	4525987	SCREW COVER	3
6	453058200	Evap. System Assy./Alfa12	1
7	452784401	IOD-12 Air Outlet Assy. (no wire)	1
8	4523693	DRAIN HOSE	1
9	4527509	Horizontal Flap	1
10	4525992	VER. FLAP A	9
10	4527510	Vertical Flap B	3
11	4523526	BERAING ASSY FAN	1
12	4527111	FAN ASSY PLASTIC	1
13	4527186	IOD-12 REAR PANEL ASSY	1
14	464220007	Mount Bracket./Low Cost ALPHA 12	1
15	4526000	TUBE CLIP	1
16	4527112R	Motor Compact 12	1
17	4525998	MOTEOR COVER	1
18	4523507	Step motor	1
20	4525988	CABLE LOCKER	1
21	453089600R	Display assy. for DELTA EHK:936A034-00	1
22	4516263	SENSOR BASE	1
23	467300198R	Controller/Delta 7/9/12 S/W:10V14	1
24	438082	Thermistor Indoor	1
25	4519813	Thermistor room	1
26	465340008	Terminal Cover/ ALPHA7/9 Flat-Type	1
28	4520416	Defrost cable EXPORT UNITS	1
29	438600R	Remote controller RC3-RC 973-600-00	1
32	453100500	Grill L axis	1
32	453100600	Grill R axis	1
33	465340064	Display Cover/ omega12 ELCO	1

14.23 Outdoor Unit: CSP 9, 12 RC R410A ISR

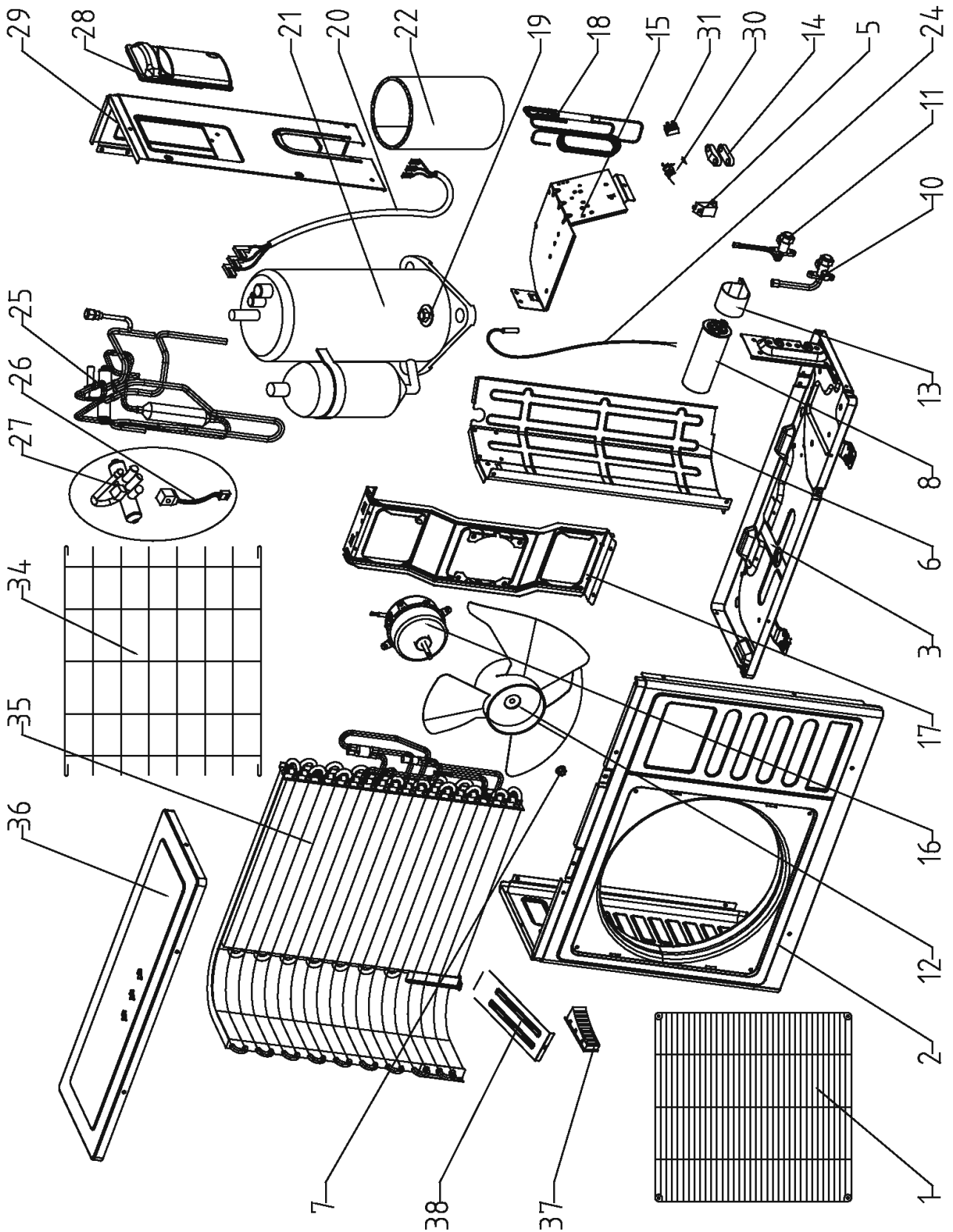

14.24

Outdoor Unit: CON SP 9 RC R410A ISR A1

No.	Item	Description	Quan.
1	4526481	Fan Cover / Grille	1
2	464660013	Front panel Painted Assy	1
3	464600046	Base Painting Assy.	1
5	455000108	Fan Capacitor	1
6	464160019	Partition Plate	1
7	4510679	Nut for Fan Motor	1
8	455000503	Compressor Capacitor	1
10	461010020	Gas Valve	1
11	461000011	Liquid Valve	1
12	4523707	Fan	1
14	204107	Cable clip Nylon	1
15	464180011	Capacitor Support/CON 9/12	1
16	466100017R	Fan Motor	1
17	453045000	Motor support	1
18	463600027	Capillary assy	1
19	201019	Nut M8 for compressor	3
20	391498	Compressor Wire Assy	1
21	460090002R	Compressor Assy.	1
22	469100003	Compressor Jacket	1
24	4516637	Out sensor / OU coil sensor	1
25	461600032	4-Way Valve Soldering Assy	1
26	4520071	4-W Valve coil(RC)/ Discharge Tubing(ST)	1
27	4518951	4-W Valve(RC)/ Suction Tubing(ST)	1
28	4526668	R lifter	1
29	464630010	Right side panel (painting plate)	1
30	4514588	5 Poles terminal block	1
31	236179	2 Poles terminal block	1
35	462300036	Condenser Soldering Assy.	1
36	4526675	Cover panel Painting Assy	1
37	436358	Left/Small Handle	1
38	4526143	CLIP OF MOTOR BRACKET	1

14.25 Outdoor Unit: CON SP 9 RC R410A ISR A2

No.	Item Code	Item Description	Quantity
1	4526481	COND Outdoor Grille	1
2	464660013	Front panel Painting assy/CON 9/12	1
3	464600046	Base Plate Painting assy/CON 9 R410A	1
5	455000108	Double patch Capacitor for fan	1
6	464160019	Partition plate/CON 9/12	1
7	4510679	Nut M6 GB6187-86	1
8	455000502	Compressor Capacitor 35uF With Screw	1
10	461010020	GasValve3/8 R410A	1
11	461000011	LiquidValve1/4 R410A	1
12	4523707	AXIAL FAN	1
14	204107	Cable clip Nylon	1
15	464180011	Capacitor Support/CON 9/12	1
16	466100017R	Metal Motor 20W 900rpm/Outdoor Unit	1
17	453045000	Motor support	1
18	463600039	CapillaryAssy.2.6x1.4x1100800/CONSP9cop3	1
19	4510677	Nut With Flange M8 -D=24	3
20	391498	Wire assy	1
21	460170001R	Compressor Assy./ PA103X1C-4DZDE	1
22	469100003	Insulation Felt/ Compressor	1
24	4516637	Out sensor Black	1
25	461600050	4-Way Valve Assy./CON 9 R410A	1
26	4520071	4-W valve coil for R410A	1
27	4518951	4-W valve SHF-4H for R410A	1
28	4526668	R lifter	1
29	464630010	Side Plate Painting Assy./Right/CON 9/12	1
30	4514588	5 Poles terminal block	1
31	236179	2 Poles terminal block	1
35	462300057	Condenser Assy/CON SP 9 cop 3.3	1
36	4526675	TOP COVER PAINTING	1
37	436358	L. lifter	1
38	4526143	LINKER OF MOTOR S	1

14.26 Outdoor Unit: GCZ 12 RC R410A ISR

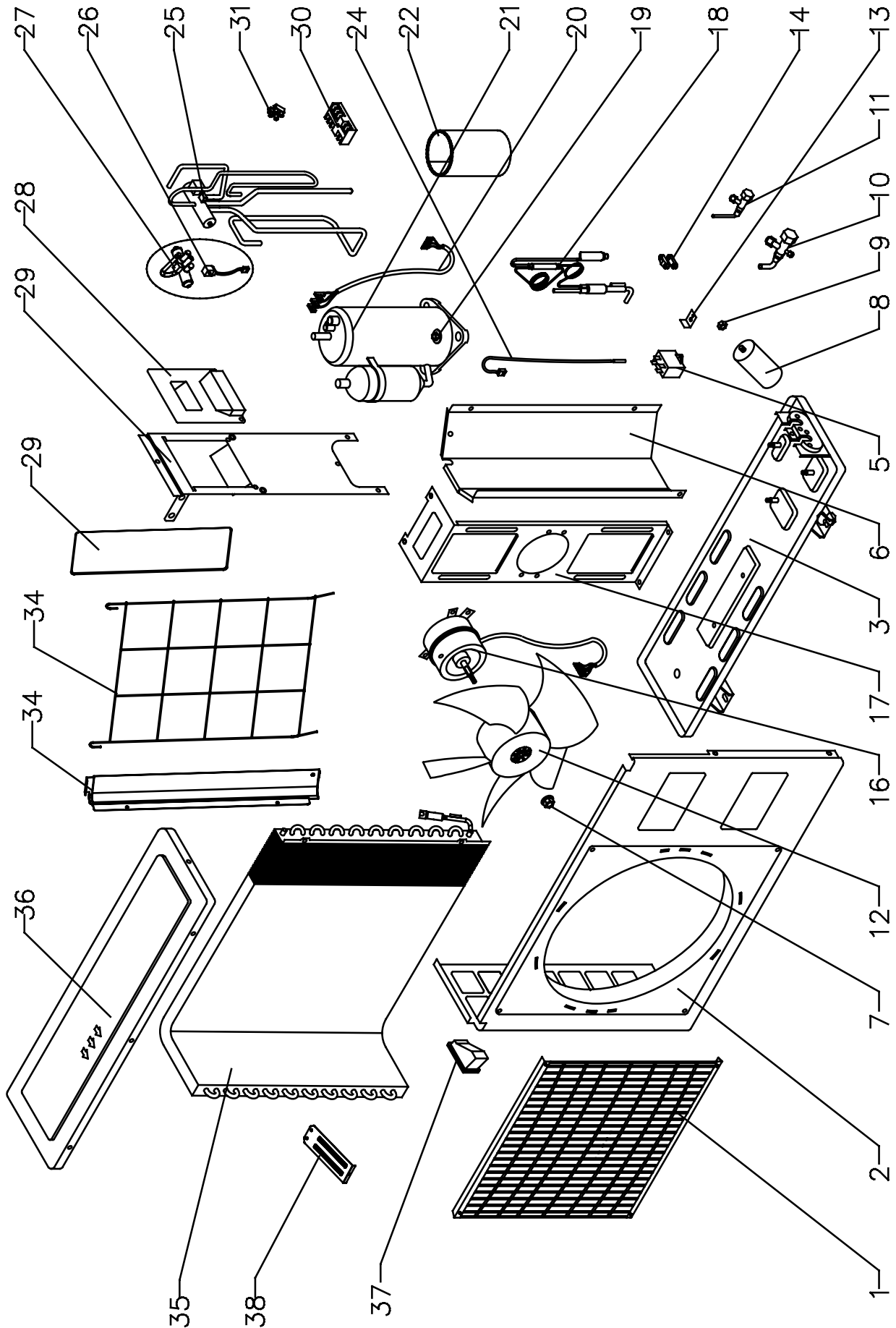

14.27 Outdoor Unit: GCZ 12 RC R410A ISR A1

No.	Item	Description	Quan.
1	464800009	Fan Cover / Grille	1
2	464660014	Front panel Painted Assy	1
3	464600044	Base Painting Assy.	1
5	455000108	Fan Capacitor	1
6	464160018	Partition Plate	1
8	455000502	Compressor Capacitor	1
10	461010019	Gas Valve	1
11	461000010	Liquid Valve	1
12	293289	Fan	1
13	4518022	Capacitor clip	1
14	204107	Cable clip Nylon	1
16	466100016R	Fan Motor	1
17	464860002	Motor support	1
18	463600029	Capillary assy	1
19	201019	Nut M8 for compressor	3
20	391498	Compressor Wire Assy	1
21	460090000R	Compressor Assy.	1
22	469100003	Compressor Jacket	1
24	4516637	Out sensor / OU coil sensor	1
25	461600033	4-Way Valve Soldering Assy	1
26	4520071	4-W Valve coil(RC)/ Discharge Tubing(ST)	1
27	4518951	4-W Valve(RC)/ Suction Tubing(ST)	1
28	436357	R.lifter	1
29	460129	Right side panel (painting plate)	1
29	464770007	Rear Plate/Right Painting Assy/GCZ 9/12	1
30	4514588	5 Poles terminal block	1
31	236179	2 Poles terminal block	1
34	464800007	Guard Net Painting Assy.	1
34	464770001	Rear Plate/Left Painting Assy	1
35	462300037	Condenser Soldering Assy.	1
36	464700009	Cover panel Painting Assy	1
37	436358	Left/Small Handle	1
38	453085800	CLIP OF MOTOR BRACKET	1

14.28 Outdoor Unit: GCZ 12 RC R410A ISR A2

No.	Item Code	Item Description	Quantity
1	464800009	Front Guard Net Painting Assy./GCZ	1
2	4516159	Front panel Painting assy	1
3	464600066	Base Plate Painting assy/CON SP 12 R410A	1
5	455000108	Double patch Capacitor for fan	1
6	464160018	Partition plate/GCZ 9/12	1
8	455000503	Compressor Capacitor With Screw	1
10	461010019	valve	1
11	461000010	LiquidValve1/4 R410A	1
12	466000002	Axial Fan D=400/CON SP 12 cop 3.3	1
13	4518022	Cap. Clip	1
14	204107	Cable clip Nylon	1
16	466100022R	Metal Motor 25W 735rpm/Outdoor Unit/CON	1
17	464860002	Motor Support Assy.	1
18	463600029	CapillaryAssy.2.6x1.4x600500	1
19	4510677	Nut With Flange M8 -D=24	3
20	391498	Wire assy	1
21	460150005R	CompressorAssy5PS132EAA22Panasonic	1
22	469100003	Insulation Felt/ Compressor	1
24	4516637	Out sensor Black	1
25	461600051	4-Way Valve Assy./GCZ 12 R410A	1
26	4520071	4-W valve coil for R410A	1
27	4518951	4-W valve SHF-4H for R410A	1
28	436357	R.lifter	1
29	460129	Side panel Painting assy	1
29	464770007	Rear Plate/Right Painting Assy/GCZ 9/12	1
30	4514588	5 Poles terminal block	1
31	236179	2 Poles terminal block	1
34	464770001	Rear Plate/Left Painting Assy	1
34	464800007	Back Guard Net Painting Assy./GCZ	1
35	462300037	Condenser Assy/GCZ 12	1
36	4516158	Cover panel Painting assy	1
37	436358	L. lifter	1
38	453085800	Connect Plate/Motor Support	1

APPENDIX A

INSTALLATION AND OPERATION MANUAL

- ▶ OPERATION MANUAL ALPHA SP 9, 12
- ▶ OPERATION MANUAL ALPHA SP 9, 12 (Delta Grill)
- ▶ INSTALLATION MANUAL ALPHA SP 9, 12