



Service Manual

Alpha / Delta Series

Indoor Units	Outdoor Units
Alpha 7	CON 7 (Alpha)
Delta 7	GCN 7
Alpha 9	GCN 9 (Alpha)
Delta 9 DF	ONG3-9 B1
	ONG3-9 B2
Alpha 12	GCN 12 (Alpha)
Delta 12 DF	ONG3-12 B1
	ONG3-12 B2
Alpha 17	ONG3-14 B1
Alpha 17	ONG3-17 (Alpha)
Delta 17 DF	ONG3-17
Delta 24	OU7-24C



REFRIGERANT

R410A

COOLING ONLY

HEAT PUMP

LIST OF EFFECTIVE PAGES

Note: Changes in the pages are indicated by a “Revision#” in the footer of each effected page (when none indicates no changes in the relevant page). All pages in the following list represent effected/ non effected pages divided by chapters.

Dates of issue for original and changed pages are:

Original 0 10 December 2004

Total number of pages in this publication is 169 consisting of the following:

Page No.	Revision No. #		Page No.	Revision No. #		Page No.	Revision No. #
----------	----------------	--	----------	----------------	--	----------	----------------

Title 3
 A 3
 i 3
 1-1 - 1-2 3
 2-1 - 2-13 3
 3-1 3
 4-1 - 4-6 3
 5-1 - 5-40 3
 6-1 - 6-8 3
 7-1 3
 8-1 - 8-5 3
 9-1 3
 10-1-10-4 3
 11-1 3
 12-1-12-32 3
 13-1-13-2 3
 14-1-14-49 3
 Appendix -A 3

- Zero in this column indicates an original page.

*Due to constant improvements please note that the data on this service manual can be modified with out notice.
 **Photos are not contractual

Table of Contents

1.	INTRODUCTION	1-1
2.	PRODUCT DATA SHEET	2-1
3.	RATING CONDITIONS	3-1
4.	OUTLINE DIMENSIONS	4-1
5.	PERFORMANCE DATA & PRESSURE CURVES	5-1
6.	SOUND LEVEL CHARACTERISTICS	6-1
7.	ELECTRICAL DATA.....	7-1
8.	WIRING DIAGRAMS	8-1
9.	ELECTRICAL CONNECTIONS.....	9-1
10.	REFRIGERATION DIAGRAMS.....	10-1
11.	TUBING CONNECTIONS.....	11-1
12.	CONTROL SYSTEM	12-1
13.	TROUBLESHOOTING	13-1
14.	EXPLODED VIEWS AND SPARE PARTS LISTS.....	14-1
15.	APPENDIX A	15-1

1. INTRODUCTION

1.1 General

The new **Alpha / Delta** split wall mounted is based on the compact range. It comprise the ST (cooling only) and RC (heat pump) models,

The indoor **Alpha / Delta** units are available as LED display types, featuring esthetic design, compact dimensions, and low noise operation.

1.2 Main Features

The **Alpha / Delta** series benefits from the most advanced technological innovations, namely:

- R410A models
- Microprocessor control.
- Infrared remote control with liquid crystal display.
- Indoor large diameter cross flow fan, allowing low noise level operation.
- Bended indoor coil with treated aluminum fins and coating for improved efficiency.
- High COP.
- Easy access to the interconnecting tubing and wiring connections, so that removing the front grill or casing is not necessary.
- Refrigerant pipes can be connected to the indoor unit from 5 different optional directions.
- Automatic treated air sweep.
- Easy installation and service.
- 4M length tubing connection kit is provided in the outdoor unit (optional).

1.3 Indoor Unit

The indoor unit is wall mounted, and can be easily fitted to many types of residential and commercial applications.

It includes:

- Casing with air inlet and outlet grills.
- A large-diameter tangential fan.
- Bended coil with treated aluminum fins.
- Motorized flaps
- Multi-speed motor with internal protection
- Advanced electronic control box assembly
- Interconnecting wiring terminal block
- Mounting plate

1.4 Filtration

The **Alpha / Delta** series presents several types of air filters

- Easily accessible, and re-usable pre-filters (mesh)
- Pre-charged electrostatic filter (optional)
- Active carbon filter (optional)

1.5 Control

The microprocessor indoor controller, and an infrared remote control, supplied as standard, provide complete operating function and programming. For further details please refer to the Operation Manual, Appendix A.

1.6 Outdoor Unit

The **Alpha / Delta** outdoor units can be installed as floor or wall mounted units by using a wall supporting bracket. The metal sheets are protected by anti-corrosion paint work allowing long life resistance. All outdoor units are pre-charged. For further information please refer to the Product Data Sheet, Chapter 2.

It includes :

- A Rotary compressor mounted in a soundproofed compartment :
- Axial fan.
- Outdoor coil with hydrophilic louver fins for RC units.
- Outlet air fan grill.
- Service valves" flare" type connection.
- Interconnecting wiring terminal block.

1.7 Tubing Connections

Flare type interconnecting tubing can be produced on site.

A connection pipe kit is provided in outdoor package.

For further details please refer to the Installation Manual, Appendix A.

1.8 Accessories

ASK (All Season Kit):

For low ambient working conditions in cooling, an ASK can be installed inside the outdoor unit. This kit allows cooling operation down to outdoor temp of -10 °C by gradually controlling the outdoor fan speed motor.

1.9 Inbox Documentation

Each unit is supplied with its own installation and operation manuals.

2. PRODUCT DATA SHEET

2.1 Alpha 7 / CON7 (Alpha)

Model Indoor Unit		Alpha 7			
Model Outdoor Unit		CON 7 (Alpha)			
Installation Method of Pipe		Flared			
Characteristics		Units	Cooling Only	Cooling	Heating
Capacity ⁽¹⁾		Btu/hr	7000	7000	7300
		kW	2.05	2.05	2.15
Power input ⁽¹⁾		kW	0.68	0.68	0.63
EER (Cooling) or COP(Heating) ⁽¹⁾		W/W	3.01	3.01	3.41
Energy efficiency class			B	B	B
Power supply		V/Ph/Hz	230V/Single/50Hz		
Rated current		A	3.0	3.0	2.8
Starting current		A	15		
Circuit breaker rating		A	10		
INDOOR	Fan type & quantity		Crossflow x 1		
	Fan speeds	H/M/L	RPM	1150/950	
	Air flow ⁽²⁾	H/M/L	m3/hr	390/320	
	External static pressure	Min-Max	Pa	0	
	Sound power level ⁽³⁾	H/M/L	dB(A)	50/44	
	Sound pressure level ⁽⁴⁾	H/M/L	dB(A)	37/32	
	Moisture removal		l/hr	0.8	
	Condensate drain tube I.D		mm	16	
	Dimensions	WxHxD	mm	680*250*180	
	Weight		kg	7	
	Package dimensions	WxHxD	mm	740*250*310	
	Packaged weight		kg	9.5	
	Units per pallet		units	36	
	Stacking height		units	9 levels	
	OUTDOOR	Refrigerant control		Capillary tube	
Compressor type, model		Rotary,TOSHIBA,PA82X1C-4DZDE			
Fan type & quantity		Propeller(direct) x 1			
Fan speeds		H/L	RPM	850	
Air flow		H/L	m3/hr	1200	
Sound power level		H/L	dB(A)	61	62
Sound pressure level ⁽⁴⁾		H/L	dB(A)	52	53
Dimensions		WxHxD	mm	610*235*490	
Weight			kg	27	27.5
Package dimensions		WxHxD	mm	720*550*360	
Packaged weight			kg	30/33.5(with kit)	30.5/34(with kit)
Units per pallet			Units	12	
Stacking height			units	4 levels	
Refrigerant type				R410A	
Refrigerant chargeless distance			Kg/m	0.72kg/7.5m	
Additional charge			kg	4m<length≤10m,0.72kg; 10m<length≤15m,0.8kg	
Connections between units		Liquid line	In.(mm)	Φ 1/4"(6.35)	
	Suction line	In.(mm)	Φ 3/8"(9.53)		
	Max.tubing length	m.	Max.15		
	Max.height difference	m.	Max.7		
Operation control type			Remote control		
Heating elements		kW			
Others					

(1) Rating conditions in accordance with ISO 5151 and ISO 13253 (for ducted units) and EN 14511.

(2) Airflow in ducted units; at nominal external static pressure.

(3) Sound power in ducted units is measured at air discharge.

(4) Sound pressure level measured at 1 meter distance from unit.

2.2 Delta 7 R410A A2 DF / GCN 7 RC R410A A2

Model Indoor Unit		Delta 7 R410A A2 DF		
Model Outdoor Unit		GCN 7 RC R410A A2		
Installation Method of Pipe		Flared		
Characteristics		Units	Cooling Heating	
Capacity (4)		Btu/hr	7780 7850	
		kW	2.28 2.30	
Power input (4)		kW	0.62 0.67	
EER (Cooling) or COP(Heating) (4)		W/W	3.70 3.45	
Energy efficiency class(SII)			A A	
Power supply		V	230	
		Ph	1	
		Hz	50	
Rated current		A	2.8 3.0	
Power factor			0.95 0.95	
Prated (IDU)		W	30	
Prated (IDU+ODU)		W	890	
Starting current		A	15	
Circuit breaker rating		A	10	
INDOOR	Fan type & quantity		Crossflow x 1	
	Fan speeds	H/M/L	RPM	1050/-/900
	Air flow (1)	H/M/L	m3/hr	450/-/380
	External static pressure	Min	Pa	0
	Sound power level (2)	H/M/L	dB(A)	50/-/44
	Sound pressure level(3)	H/M/L	dB(A)	37/-/31
	Moisture removal		l/hr	0.74
	Condensate drain tube I.D		mm	16
	Dimensions	WxHxD	mm	680x250x180
	Net Weight		kg	6
	Package dimensions	WxHxD	mm	740x310x248
	Packaged weight		kg	8.5
	Units per pallet		units	32
	Stacking height		units	8 levels
OUTDOOR	Refrigerant control		Capillary tube	
	Compressor type,model		Rotary,Toshiba(GMCC),PA82X1C-4DZDE	
	Fan type & quantity		Propeller(direct) x 1	
	Fan speeds	H	RPM	830
	Air flow	H	m3/hr	1450
	Sound power level	H	dB(A)	60
	Sound pressure level(3)	H	dB(A)	50
	Dimensions	WxHxD	mm	830x545x245
	Net Weight		kg	31.5
	Package dimensions	WxHxD	mm	870x600x320
	Packaged weight		kg	34
	Units per pallet		Units	12
	Stacking height		units	3 levels
	Refrigerant type			R410A
	Refrigerant chargeless distance		kg(7.5m)	0.8kg
	Additional charge			4m≤Length≤10m: +0g; 10m□Length≤15m: +50g
	Connections between units	Liquid line	In.(mm)	1/4"(6.35)
Suction line		In.(mm)	3/8"(9.53)	
Max.tubing length		m.	Max.15	
Max.height difference		m.	Max.7	
Operation control type			Remote control	
Heating elements(Optional)		kW		
Others				

- (1) Rating conditions in accordance with ISO 5151 and ISO 13253 (for ducted units) and EN 14511.
- (2) Airflow in ducted units; at nominal external static pressure.
- (3) Sound power in ducted units is measured at air discharge.
- (4) Sound pressure level measured at 1 meter distance from unit.

2.3 Alpha 9 / GCN9 (Alpha)

Model Indoor Unit			Alpha 9		
Model Outdoor Unit			GCN 9 (Alpha)		
Installation Method of Pipe			Flared		
Characteristics		Units	Cooling Only	Cooling	Heating
Capacity ⁽¹⁾		Btu/hr	9000	9000	9650
		kW	2.64	2.64	2.83
Power input ⁽¹⁾		kW	0.87	0.87	0.93
EER (Cooling) or COP(Heating) ⁽¹⁾		W/W	3.03	3.03	3.04
Energy efficiency class			B	B	D
Power supply		V/Ph/Hz	230V/Single/50Hz		
Rated current		A	3.9	3.9	4.1
Starting current		A	21.7		
Circuit breaker rating		A	10		
INDOOR	Fan type & quantity		Crossflow x 1		
	Fan speeds	H/M/L	RPM 1310/1100		
	Air flow ⁽²⁾	H/M/L	m3/hr 450/360		
	External static pressure	Min-Max	Pa 0		
	Sound power level ⁽³⁾	H/M/L	dB(A) 53/49		
	Sound pressure level ⁽⁴⁾	H/M/L	dB(A) 41/35		
	Moisture removal		l/hr 1.2		
	Condensate drain tube I.D		mm 16		
	Dimensions	WxHxD	mm 680*250*180		
	Weight		kg 7		
	Package dimensions	WxHxD	mm 740*250*310		
	Packaged weight		kg 9.5		
	Units per pallet		units 36		
	Stacking height		units 9 levels		
	OUTDOOR	Refrigerant control		Capillary tube	
Compressor type,model		Rotary,TOSHIBA,PA108X1C-4FZDE			
Fan type & quantity		Propeller(direct) x 1			
Fan speeds		H/L	RPM 750		
Air flow		H/L	m3/hr 1370		
Sound power level		H/L	59	61	
Sound pressure level ⁽⁴⁾		H/L	49	51	
Dimensions		WxHxD	mm 830x245x545		
Weight			32.5	33.5	
Package dimensions		WxHxD	mm 880x320x610		
Packaged weight			35/38.5(with kit)	36/39.5(with kit)	
Units per pallet			Units 9		
Stacking height			units 3levels		
Refrigerant type		R410A			
Refrigerant chargless distance		kg/m	0.85kg/7.5m	0.9kg/7.5m	
Additional charge		kg	4m<length≤10m,0.85kg 10m<length≤15m,0.93kg	4m<length≤10m,0.9kg 10m<length≤15m,0.98kg	
Connections between units	Liquid line	In.(mm)	Φ 1/4"(6.35)		
	Suction line	In.(mm)	Φ 3/8"(9.53)		
	Max.tubing length	m.	Max.15		
	Max.height difference	m.	Max.7		
Operation control type			Remote control		
Heating elements		kW			
Others					

- (1) Rating conditions in accordance with ISO 5151 and ISO 13253 (for ducted units). and EN 14511
- (2) Airflow in ducted units; at nominal external static pressure.
- (3) Sound power in ducted units is measured at air discharge.
- (4) Sound pressure level measured at 1 meter distance from unit.

2.4 Delta 9 RC/ST fixed RPM R410A / ONG3-9 R410A B1

Model		Indoor unit	Delta 9RC/ST fixed rpm R410A		
		Outdoor unit	ONG3-9 R410A B1		
Characteristics		Units	Cooling Only	Cooling	Heating
Capacity (4)	Total	Btu/hr	8870	8870	9720
		kW	2.6	2.6	2.85
	Sensible capacity	kW	1940	1940	-
	Moisture removal	l/hr	0.98	0.98	-
Power input (4)		kW	0.78	0.78	0.850
EER (Cooling) or COP(Heating) (4)		W/W	3.34	3.34	3.35
Power supply		V/Ph/Hz	220-240V/Single/50Hz		
Running Current (Rated)		A	3.5	3.5	3.8
Starting current		A	21.7		
Circuit breaker rating		A	10		
INDOOR	Model		Delta 9RC/ST fixed rpm R410A		
	Fan type & quantity		Centifugal x1		
	Fan speeds		H/M/L	RPM	1310/-/1100
	Air flow (1)	H	L/S	125	
		M		-	
		L		100	
	Coil	Area	M ²	0.126	
		Rows	Qty	2	
		Fin Spacing	mm	1.5	
	External static pressure		Nom	Pa	0
	Airflow direction control		-		
	Air Filter		supplied by others		
	Running Current (Rated)		amp	0.13	
	Sound	Power level (H/M/L)	dB(A)	53/-/49	
		Pressure level(3) (H/M/L)	dB(A)	41/-/35	
	Cooling Temperature Operating Range (Min/Max)		21°C DB (15 °C WB) / 32°C DB (23°C WB)		
	Heating Temperature Operating Range (Min/Max)		-	10°C /27°C	
	Condensate drain tube I.D		mm	16	
	Dimensions/(packaged)		WxDxH	mm 680*250*180 / 740*310*248	
	Weight		kg	9.5	
OUTDOOR	Model		ONG3-9 R410A B1		
	Compressor	Type	Single Rotary		
		Model	PA103X1C-4DZDE		
		Motor kW	watt	840/870	
		Running Current (Rated)	amp	3.90/3.80	
		Motor Speed	RPM	3000	
	Fan	Type	Propeller(direct) x 1		
		Blades	Qty	3	
		Diameter	mm	400	
		Air flow	m3/hr	1750	
		Motor Type	fixed RPM		
		Speed (H/L)	RPM	730	
		Motor output	watt	20	
	Coil	Area	M ²	0.45	
		Rows	Qty	2	
		Fin Spacing	mm	1.5	
	Sound	Power level (H/L)	dB(A)	60 / -	
		Pressure level(3) (H/L)	dB(A)	49 / -	
	Cooling Temperature Operating Range (Min/Max)		21°C/ 46°C		
	Heating Temperature Operating Range (Min/Max)		-9°C / 24°C		
Dimensions/(packaged)		WxDxH	mm 795*610*290 / 970*650*394		
Weight(packaged)		kg	32 / 34.5	33 / 35.5	
Refrigerant	Type	R410A			
	Control	Capillary tube			
	Chargless distance	kg/m	0.91kg/7.5m		
	Add charge per mtr	g/m	4m < L≤10m: +0g; 10m < L≤15m: +80g		
Connections between units	Liquid line	In.(mm)	1/4"(6.35)		
	Suction line	In.(mm)	3/8"(9.53)		
	Type	Flared			
	Max.tubing length	m.	Max15		
	Max.height difference	m.	Max.8		
Operation control type		RC7 Remote control			
Heating elements (Option)		kW	-	-	
Others			-	-	

(1) Airflow in ducted units;at nominal external static pressure.

(2)Sound power in ducted units is measured at air discharge.

(3)Sound pressure level measured at 1-meter distance from unit.

(4)Rating conditions in accordance to AS 3823, ISO 5151 and ISO 13253 (for ducted units).

2.5 Delta 9 R410A B2 DF / ONG3-9 RC R410A B2 ISR

Model Indoor Unit		Delta 9 R410A B2 DF ISR		
Model Outdoor Unit		ONG3-9 RC R410A B2 ISR		
Installation Method of Pipe		Flared		
Characteristics		Units	Cooling Heating	
Capacity (4)	Btu/hr		9210 9890	
	kW		2.70 2.90	
Power input (4)	kW		0.75 0.83	
EER (Cooling) or COP(Heating) (4)	W/W		3.60 3.50	
Energy efficiency class(SII)			C C	
Power supply	V		230	
	Ph		1	
	Hz		50	
Rated current	A		3.4 3.8	
Power factor			0.95 0.95	
Prated (IDU)	W		30	
Prated (IDU+ODU)	W		1050	
Starting current	A		16.6	
Circuit breaker rating	A		10	
INDOOR	Fan type & quantity		Crossflow x 1	
	Fan speeds	H/M/L	RPM	1320/-/1100
	Air flow (1)	H/M/L	m3/hr	450/-/360
	External static pressure	Min	Pa	0
	Sound power level (2)	H/M/L	dB(A)	53/-/49
	Sound pressure level(3)	H/M/L	dB(A)	41/-/35
	Moisture removal	l/hr		1.02
	Condensate drain tube I.D	mm		16
	Dimensions	WxHxD	mm	680x250x180
	Net Weight	kg		6
	Package dimensions	WxHxD	mm	740x310x248
	Packaged weight	kg		8.5
	Units per pallet	units		32
	Stacking height	units		8 levels
OUTDOOR	Refrigerant control		Capillary tube	
	Compressor type,model		Rotary,Toshiba(GMCC),PA103X1C-4FZDE1	
	Fan type & quantity		Propeller(direct) x 1	
	Fan speeds	H	RPM	780
	Air flow	H	m3/hr	1800
	Sound power level	H	dB(A)	59
	Sound pressure level(3)	H	dB(A)	49
	Dimensions	WxHxD	mm	795x610x290
	Net Weight	kg		33
	Package dimensions	WxHxD	mm	970x650x394
	Packaged weight	kg		35.5
	Units per pallet	Units		9
	Stacking height	units		3 levels
	Refrigerant type			R410A
	Refrigerant chargeless distance	kg(7.5m)		0.95kg
	Additional charge			4m≤Length≤10m: +0g; 10m≤Length≤15m: +50g
	Connections between units	Liquid line	In.(mm)	1/4"(6.35)
Suction line		In.(mm)	3/8"(9.53)	
Max.tubing length		m.	Max.15	
Max.height difference		m.	Max.7	
Operation control type			Remote control	
Heating elements(Optional)	kW			
Others				

- (1) Rating conditions in accordance with ISO 5151 and ISO 13253 (for ducted units) and EN 14511.
- (2) Airflow in ducted units; at nominal external static pressure.
- (3) Sound power in ducted units is measured at air discharge.
- (4) Sound pressure level measured at 1 meter distance from unit.

2.6 Alpha 12 / GCN12 (Alpha)

Model Indoor Unit		Alpha 12			
Model Outdoor Unit		GCN 12 (Alpha)			
Installation Method of Pipe		Flared			
Characteristics		Units	Cooling Only	Cooling	Heating
Capacity ⁽¹⁾		Btu/hr	12000	12000	12900
		kW	3.50	3.50	3.78
Power input ⁽¹⁾		kW	1.16	1.16	1.17
EER (Cooling) or COP(Heating) ⁽¹⁾		W/W	3.02	3.02	3.23
Energy efficiency class			B	B	C
Power supply		V/Ph/Hz	230V/Single/50Hz		
Rated current		A	5.2	5.2	5.2
Starting current		A	31.5		
Circuit breaker rating		A	10		
INDOOR	Fan type & quantity		Crossflow x 1		
	Fan speeds	H/M/L	RPM	1210/950	
	Air flow ⁽²⁾	H/M/L	m3/hr	620/460	
	External static pressure	Min-Max	Pa	0	
	Sound power level ⁽³⁾	H/M/L	dB(A)	53/47	
	Sound pressure level ⁽⁴⁾	H/M/L	dB(A)	40/33	
	Moisture removal		l/hr	1.5	
	Condensate drain tube I.D		mm	16	
	Dimensions	WxHxD	mm	840*250*180	
	Weight		kg	8	
	Package dimensions	WxHxD	mm	900*250*310	
	Packaged weight		kg	11	
	Units per pallet		units	36	
	Stacking height		units	9 levels	
OUTDOOR	Refrigerant control		Capillary tube		
	Compressor type,model		Rotary,TOSHIBA,PA145X2C-4FT		
	Fan type & quantity		Propeller(direct) x 1		
	Fan speeds	H/L	RPM	830	
	Air flow	H/L	m3/hr	1450	
	Sound power level	H/L	dB(A)	65	65
	Sound pressure level ⁽⁴⁾	H/L	dB(A)	54	54
	Dimensions	WxHxD	mm	830x245x545	
	Weight		kg	37	38
	Package dimensions	WxHxD	mm	880x320x610	
	Packaged weight		kg	39.5/43(with kit)	40.5/44(with kit)
	Units per pallet		Units	9	
	Stacking height		units	3 levels	
	Refrigerant type			R410A	
	Refrigerant chargless distance		kg/m	0.89kg/7.5m	
	Additional charge per 1 meter		g/m	4m≤length≤10m,0.89kg 10m<length≤15m,0.97kg	
	Connections between units	Liquid line	In.(mm)	Φ1/4"(6.35)	
Suction line		In.(mm)	ø3/8"(9.53)		
Max.tubing length		m.	Max.15		
Max.height difference		m.	Max.7		
Operation control type			Remote control		
Heating elements		kW			
Others					

(1) Rating conditions in accordance with ISO 5151 and ISO 13253 (for ducted units) and EN 14511.

(2) Airflow in ducted units; at nominal external static pressure.

(3) Sound power in ducted units is measured at air discharge.

(4) Sound pressure level measured at 1 meter distance from unit.

2.7 Delta 12 RC/ST fixed RPM R410A / ONG3-12 R410A B1

Model		Indoor unit		Delta 12RC/ST fixed rpm R410A			
Characteristics		Outdoor unit		ONG3-12 R410A B1			
		Units		Cooling Only	Cooling	Heating	
Capacity (4)	Total	Btu/hr		11260	11260	12280	
		kW		3.3	3.3	3.60	
	Sensible capacity		kW		2.585	2.585	-
	Moisture removal		l/hr		1.05	1.05	-
Power input (4)		kW		1.01	1.01	1.030	
EER (Cooling) or COP(Heating) (4)		W/W		3.26	3.26	3.47	
Power supply		V/Ph/Hz		220-240V/Single/50Hz			
Running Current (Rated)		A		4.6	4.6	4.7	
Starting current		A		24			
Circuit breaker rating		A		10			
Model				Delta 12RC/ST fixed rpm R410A			
Fan type & quantity				Centifugal x1			
Fan speeds		H/M/L		RPM			
				1210/-/950			
Air flow (1)	H		L/S	172			
	M			-			
	L			127			
Coil	Area		M ²		0.167		
	Rows		Qty		2		
	Fin Spacing		mm		1.5		
	External static pressure		Nom		Pa		
				0			
Airflow direction control				-			
Air Filter				supplied by others			
Running Current (Rated)		amp		0.13			
Sound	Power level (H/M/L)		dB(A)		53/-/47		
	Pressure level(3) (H/M)		dB(A)		40/-/33		
Cooling Temperature Operating Range (Min/Max)				21 °C DB (15°C WB) / 32°C DB (23°C WB)			
Heating Temperature Operating Range (Min/Max)				- / 10 °C ~27 °C			
Condensate drain tube I.D		mm		16			
Dimensions/(packaged)		WxDxH		mm			
				840*250*180 / 900*310*248			
Weight		kg		10.5			
Model				ONG3-12 R410A B1			
Compressor	Type		Single Rotary				
	Model		PANSONIC, 5PS132EAA22				
	Motor kW		watt		1085/1115		
	Running Current (Rated)		amp		5.05/4.85		
	Motor Speed		RPM		3000		
Fan	Type		Propeller(direct) x 1				
	Blades		Qty		3		
	Diameter		mm		400		
	Air flow		m3/hr		1850		
	Motor Type		Fixed RPM				
	Speed (H/L)		RPM		810		
Coil	Motor output		watt		25		
	Area		M ²		0.45		
	Rows		Qty		2		
	Fin Spacing		mm		1.5		
Sound	Power level (H/L)		dB(A)		61/-		
	Pressure level(3) (H/L)		dB(A)		50/-		
Cooling Temperature Operating Range (Min/Max)				21 °C / 46 °C			
Heating Temperature Operating Range (Min/Max)				-9 °C / 24 °C			
Dimensions/(packaged)		WxDxH		mm			
				795*610*290 / 970*650*394			
Weight(packaged)		kg		33.5 / 36 / 34.5 / 37			
Refrigerant	Type		R410A				
	Control		Capillary tube				
	Chargless distance		kg/m		0.93kg/7.5m		
	Add charge per mtr		g/m		4m < L≤10m: +0g; 10m < L≤15m: +80g		
Connections between units	Liquid line		In.(mm)		1/4"(6.35)		
	Suction line		In.(mm)		3/8"(9.53)		
	Type		Flared				
	Max.tubing length		m.		Max15		
Max.height difference		m.		Max.8			
Operation control type				RC7 Remote control			
Heating elements (Option)		kW		-			
Others				-			

(1) Airflow in ducted units;at nominal external static pressure.

(2)Sound power in ducted units is measured at air discharge.

(3)Sound pressure level measured at 1-meter distance from unit.

(4)Rating conditions in accordance to AS 3823, ISO 5151 and ISO 13253 (for ducted units).

2.8 Delta 12 R410A B2 DF / ONG3-12 RC R410A B2 ISR

Model Indoor Unit		Delta 12 R410A B2 DF ISR		
Model Outdoor Unit		ONG3-12 RC R410A B2 ISR		
Installation Method of Pipe		Flared		
Characteristics		Units	Cooling Heating	
Capacity (4)		Btu/hr	12110 12620	
		kW	3.55 3.70	
Power input (4)		kW	0.99 1.03	
EER (Cooling) or COP(Heating) (4)		W/W	3.60 3.60	
Energy efficiency class(SII)			A A	
Power supply		V	230	
		Ph	1	
		Hz	50	
Rated current		A	4.5 4.7	
Power factor			0.95 0.95	
Prated (IDU)		W	30	
Prated (IDU+ODU)		W	1430	
Starting current		A	24	
Circuit breaker rating		A	10	
INDOOR	Fan type & quantity		Crossflow x 1	
	Fan speeds	H/M/L	RPM	1250/-/880
	Air flow (1)	H/M/L	m3/hr	620/-/390
	External static pressure	Min	Pa	0
	Sound power level (2)	H/M/L	dB(A)	53/-/47
	Sound pressure level(3)	H/M/L	dB(A)	40/-/33
	Moisture removal		l/hr	1.26
	Condensate drain tube I.D		mm	16
	Dimensions	WxHxD	mm	840x250x180
	Net Weight		kg	8
	Package dimensions	WxHxD	mm	900x310x248
	Packaged weight		kg	10.5
	Units per pallet		units	32
	Stacking height		units	8 levels
OUTDOOR	Refrigerant control		Capillary tube	
	Compressor type,model		Rotary,Panasonic,5PS132EAC22	
	Fan type & quantity		Propeller(direct) x 1	
	Fan speeds	H	RPM	810
	Air flow	H	m3/hr	1850
	Sound power level	H	dB(A)	62
	Sound pressure level(3)	H	dB(A)	52
	Dimensions	WxHxD	mm	795x610x290
	Net Weight		kg	34.5
	Package dimensions	WxHxD	mm	970x650x394
	Packaged weight		kg	37
	Units per pallet		Units	9
	Stacking height		units	3 levels
	Refrigerant type			R410A
	Refrigerant chargless distance		kg(7.5m)	0.98kg
	Additional charge			4m≤Length≤10m: +0g; 10m≤Length≤15m: +70g
	Connections between units	Liquid line	In.(mm)	1/4"(6.35)
Suction line		In.(mm)	3/8"(9.53)	
Max.tubing length		m.	Max.15	
Max.height difference		m.	Max.7	
Operation control type			Remote control	
Heating elements (Option)		kW		
Others				

- (1) Rating conditions in accordance with ISO 5151 and ISO 13253 (for ducted units) and EN 14511.
- (2) Airflow in ducted units; at nominal external static pressure.
- (3) Sound power in ducted units is measured at air discharge.
- (4) Sound pressure level measured at 1 meter distance from unit.

2.9 Delta 17 R410A B1 DF / ONG3-14 RC R410A B1 ISR

Model Indoor Unit		DELTA 17 R410A B1 DF ISR	
Model Outdoor Unit		ONG3-14 RC R410A B1 ISR	
Installation Method of Pipe		Flared	
Characteristics		Units	Cooling Heating
Capacity (4)		Btu/hr	16040
		kW	4.70
Power input (4)		kW	1.40
EER (Cooling) or COP(Heating) (4)		W/W	3.38
Energy efficiency class(SII)			C
Power supply		V	230
		Ph	1
		Hz	50
Rated current		A	6.4
Power factor			0.95
Prated (IDU)		W	42
Prated (IDU+ODU)		W	1830
Starting current		A	28.4
Circuit breaker rating		A	15
INDOOR	Fan type & quantity		Crossflow x 1
	Fan speeds	H/M/L	RPM
	Air flow (1)	H/M/L	m3/hr
	External static pressure	Min	Pa
	Sound power level (2)	H/M/L	dB(A)
	Sound pressure level(3)	H/M/L	dB(A)
	Moisture removal		l/hr
	Condensate drain tube I.D		mm
	Dimensions	WxHxD	mm
	Net Weight		kg
	Package dimensions	WxHxD	mm
	Packaged weight		kg
	Units per pallet		units
	Stacking height		units
OUTDOOR	Refrigerant control		Capillary tube
	Compressor type,model		Rotary,Panasonic,5KS170EAB21
	Fan type & quantity		Propeller(direct) x 1
	Fan speeds	H	RPM
	Air flow	H	m3/hr
	Sound power level	H	dB(A)
	Sound pressure level(3)	H	dB(A)
	Dimensions	WxHxD	mm
	Net Weight		kg
	Package dimensions	WxHxD	mm
	Packaged weight		kg
	Units per pallet		Units
	Stacking height		units
	Refrigerant type		R410A
	Refrigerant chargeless distance		kg(7.5m)
	Additional charge		4m≤Length≤10m: +0g; 10m≤Length≤15m: +150g
	Connections between units	Liquid line	In.(mm)
Suction line		In.(mm)	1/2"(12.7)
Max.tubing length		m.	Max.15
Max.height difference		m.	Max.7
Operation control type			Remote control
Heating elements (Option)		kW	
Others			

(1) Rating conditions in accordance with ISO 5151 and ISO 13253 (for ducted units) and EN 14511.

(2) Airflow in ducted units; at nominal external static pressure.

(3) Sound power in ducted units is measured at air discharge.

(4) Sound pressure level measured at 1 meter distance from unit.

2.10 Alpha 17 / ONG3-17 (Alpha)

Model Indoor Unit		Alpha 17			
Model Outdoor Unit		ONG3 17 (Alpha)			
Installation Method of Pipe		Flared			
Characteristics		Units	cooling only	Cooling	Heating
Capacity ⁽¹⁾		Btu/hr	17570	17570	18250
		kW	5.15	5.15	5.35
Power input ⁽¹⁾		kW	1.70	1.70	1.65
EER (Cooling) or COP(Heating) ⁽¹⁾		W/W	3.03	3.03	3.24
Energy efficiency class			B	B	C
Power supply		V/Ph/Hz	230V/Single/50Hz		
Rated current		A	7.6	7.6	7.4
Starting current		A	30		
Circuit breaker rating		A	15		
INDOOR	Fan type & quantity		Cross flow x 1		
	Fan speeds	H/M/L	RPM		
	Air flow ⁽²⁾	H/M/L	m3/hr		
	External static pressure	Min-Max	Pa		
	Sound power level ⁽³⁾	H/M/L	dB(A)		
	Sound pressure level ⁽⁴⁾	H/M/L	dB(A)		
	Moisture removal		l/hr		
	Condensate drain tube I.D		mm		
	Dimensions	WxHxD	mm		
	Weight		kg		
	Package dimensions	WxHxD	mm		
	Packaged weight		kg		
	Units per pallet		units		
	Stacking height		units		
	OUTDOOR	Refrigerant control		Capillary tube	
Compressor type, model		Rotary,TOSHIBA,PA200X2CS-4KT1			
Fan type & quantity		Propeller(direct) x 1			
Fan speeds		H/L	RPM		
Air flow		H/L	m3/hr		
Sound power level		H/L	64	65	
Sound pressure level ⁽⁴⁾		H/L	53	54	
Dimensions		WxHxD	mm		
Weight			42	43	
Package dimensions		WxHxD	mm		
Packaged weight			45/49(with kit)	46/50(with kit)	
Units per pallet			Units		
Stacking height			units		
Refrigerant type			R410A		
Refrigerant chargeless distance			kg/m		
Additional charge per 1 meter		g/m			
		4m ≤ L ≤10M:0g 10m ≤ L ≤15M:+100g			
Connections between units	Liquid line	ln.(mm)	ø1/4"(6.35)		
	Suction line	ln.(mm)	ø 1/2"(12.7)		
	Max.tubing length	m.	Max.15		
	Max.height difference	m.	Max.7		
Operation control type		Remote Control			
Heating elements		kW			
Others		ASK Factory Option			

(1) Rating conditions in accordance with ISO 5151 and ISO 13253 (for ducted units) and EN 14511.

(2) Airflow in ducted units; at nominal external static pressure.

(3) Sound power in ducted units is measured at air discharge.

(4) Sound pressure level measured at 1 meter distance from unit.

2.11 Delta 17 RC/ST fixed RPM R410A / ONG3-17 (Alpha)

Model Indoor Unit			Delta 17RC/ST fixed rpm R410A		
Model Outdoor Unit			ONG3 17 (Alpha)		
Installation Method of Pipe			Flared		
Characteristics		Units	cooling only	Cooling	Heating
Capacity ⁽¹⁾		Btu/hr	17570	17570	18250
		kW	5.15	5.15	5.35
Power input ⁽¹⁾		kW	1.70	1.70	1.65
EER (Cooling) or COP(Heating) ⁽¹⁾		W/W	3.03	3.03	3.24
Energy efficiency class			B	B	C
Power supply		V/Ph/Hz	230V/Single/50Hz		
Rated current		A	7.6	7.6	7.4
Starting current		A	30		
Circuit breaker rating		A	15		
INDOOR	Fan type & quantity		Cross flow x 1		
	Fan speeds	H/M/L	RPM		
	Air flow ⁽²⁾	H/M/L	m3/hr		
	External static pressure	Min-Max	Pa		
	Sound power level ⁽³⁾	H/M/L	dB(A)		
	Sound pressure level ⁽⁴⁾	H/M/L	dB(A)		
	Moisture removal		l/hr		
	Condensate drain tube I.D		mm		
	Dimensions	WxHxD	mm		
	Weight		kg		
	Package dimensions	WxHxD	mm		
	Packaged weight		kg		
	Units per pallet		units		
	Stacking height		units		
OUTDOOR	Refrigerant control		Capillary tube		
	Compressor type, model		Rotary,TOSHIBA,PA200X2CS-4KT1		
	Fan type & quantity		Propeller(direct) x 1		
	Fan speeds	H/L	RPM		
	Air flow	H/L	m3/hr		
	Sound power level	H/L	64	65	
	Sound pressure level ⁽⁴⁾	H/L	53	54	
	Dimensions	WxHxD	mm		
	Weight		42	43	
	Package dimensions	WxHxD	mm		
	Packaged weight		45/49(with kit)	46/50(with kit)	
	Units per pallet		Units		
	Stacking height		units		
	Refrigerant type		R410A		
	Refrigerant chargeless distance		kg/m		
	Additional charge per 1 meter		g/m		
	Connections between units	Liquid line	ln.(mm)	ø1/4"(6.35)	
Suction line		ln.(mm)	ø 1/2"(12.7)		
Max.tubing length		m.	Max.15		
Max.height difference		m.	Max.7		
Operation control type		Remote Control			
Heating elements		kW			
Others		ASK Factory Option			

(1) Rating conditions in accordance with ISO 5151 and ISO 13253 (for ducted units) and EN 14511.

(2) Airflow in ducted units; at nominal external static pressure.

(3) Sound power in ducted units is measured at air discharge.

(4) Sound pressure level measured at 1 meter distance from unit.

2.12 Delta 17 R410A DF / ONG3-17 RC R410A

Model Indoor Unit		Delta 17 R410A DF	
Model Outdoor Unit		ONG3-17 RC R410A	
Installation Method of Pipe		Flared	
Characteristics		Units	Cooling
			Heating
Capacity ⁽⁴⁾		Btu/hr	18430
		kW	5.40
Power input ⁽⁴⁾		kW	1.69
EER (Cooling) or COP(Heating) (4)		W/W	3.20
Energy efficiency class(SII)			F
Power supply		V	230
		Ph	1
		Hz	50
Rated current		A	7.7
Power factor			0.95
Prated (IDU)		W	40
Prated (IDU+ODU)		W	2150
Starting current		A	32
Circuit breaker rating		A	15
INDOOR	Fan type & quantity		Crossflow x 1
	Fan speeds	H/M/L	RPM
	Air flow ⁽¹⁾	H/M/L	m3/hr
	External static pressure	Min	Pa
	Sound power level ⁽²⁾	H/M/L	dB(A)
	Sound pressure level ⁽³⁾	H/M/L	dB(A)
	Moisture removal		l/hr
	Condensate drain tube I.D		mm
	Dimensions	WxHxD	mm
	Net Weight		kg
	Package dimensions	WxHxD	mm
	Packaged weight		kg
	Units per pallet		units
	Stacking height		units
OUTDOOR	Refrigerant control		Capillary tube
	Compressor type,model		Rotary,TOSHIBA PA200X2CS-4KT1
	Fan type & quantity		Propeller(direct) x 1
	Fan speeds	H	RPM
	Air flow	H	m3/hr
	Sound power level	H	dB(A)
	Sound pressure level ⁽³⁾	H	dB(A)
	Dimensions	WxHxD	mm
	Net Weight		kg
	Package dimensions	WxHxD	mm
	Packaged weight		kg
	Units per pallet		Units
	Stacking height		units
	Refrigerant type		R410A
	Refrigerant chargless distance		kg(7.5m)
	Additional charge		4m≤Length≤10m: +0g; 10m≤Length≤15m: +100g
	Connections between units	Liquid line	In.(mm)
Suction line		In.(mm)	1/2"(12.7)
Max.tubing length		m.	Max.15
Max.height difference		m.	Max.7
Operation control type			Remote control
Heating elements (Option)		kW	
Others			

(1) Rating conditions in accordance with ISO 5151 and ISO 13253 (for ducted units) and EN 14511.

(2) Airflow in ducted units; at nominal external static pressure.

(3) Sound power in ducted units is measured at air discharge.

(4) Sound pressure level measured at 1 meter distance from unit.

2.13 Delta 24 R410A / OU7-24C R410A

Model Indoor Unit			Delta 24				
Model Outdoor Unit			OU7-24C				
Installation method			WALL MOUNTED				
Characteristics		Units	Cooling only	Cooling	Heating		
Capacity ⁽¹⁾		Btu/hr	23100	23100	24150		
		kW	6.77	6.77	7.08		
Power input ⁽¹⁾		kW	2.24	2.24	2.35		
COP ⁽¹⁾		W/W	3.02	3.02	2.95		
Energy efficiency class			B	B	D		
Power supply		V/ Ph /Hz	230/50/1				
Rated current		A	10.5		11.0		
Starting current		A	63				
Circuit breaker rating		A	20				
INDOOR	Fan type & quantity		CROSS FLOW *1				
	Fan speeds	H/ M/ L	RPM	1300	1200	1100	
	Air flow ⁽²⁾	H/ M/ L	m ₃ /hr	910	820	740	
	External static pressure		Min-Max	Pa			
	Sound power level ⁽³⁾		H/ M/ L	dB(A)			
	Sound pressure level ⁽⁴⁾		H/ M/ L	dB(A)			
	Moisture removal		L/hr	2.3			
	Condensate drain tube I.D		mm	16			
	Dimensions		W/ H / D	mm	1060	295	210
	Weight		kg	15			
	Package dimensions		W/ H / D	mm	1125	360	280
	Packaged weight		kg	18			
	Units per pallet		Units	16			
	Stacking height		Units	8			
	OUTDOOR	Refrigerant control		CAPILLARY TUBE			
Compressor type, model		ROTARY					
Fan type & quantity		AXIAL*1					
Fan speeds		H / L	RPM	850		720	
Air flow		H / L	m ₃ /hr	3100		2600	
Sound power level		H / L	dB(A)				
Sound pressure level ⁽⁴⁾		H / L	dB(A)				
Dimensions		W/ H / D	mm	900	680	340	
Weight		kg	64				
Package dimensions		W/ H / D	mm	985	730	406	
Packaged weight		kg	67				
Units per pallet		Units	6				
Stacking height		Units	2				
Refrigerant type			R410A				
Refrigerant chargeless distance		kg/m	1.7 / 7.5				
Additional charge		g/m	7.5m<Add 30g / <15m				
Connections between units		Liquid line		In.	3/8		
	Suction line		In.	5/8			
	Max. tubing length		m.	15			
	Max. height difference		m.	7			
Operation control type			LCD REMOTE CONTROL				
Heating elements		kW					
Others							

(1) Rating conditions in accordance with ISO 5151 and ISO 13253 (for ducted units) and EN 14511.

(2) Airflow in ducted units; at nominal external static pressure.

(3) Sound power in ducted units is measured at air discharge.

(4) Sound pressure level measured at 1 meter distance from unit.

3. RATING CONDITIONS

Standard conditions in accordance with ISO 5151, ISO 13253 (for ducted units) and EN 14511.

Cooling:

Indoor: 27°C DB 19°C WB

Outdoor: 35°C DB

Heating:

Indoor: 20°C DB

Outdoor: 7°C DB 6°C WB

3.1 Operating Limits

3.1.1 R410A

		Indoor	Outdoor
Cooling	Upper limit	32°C DB 23°C WB	46°C DB
	Lower limit	21°C DB 15°C WB	10°C DB
Heating	Upper limit	27°C DB	24°C DB 18°C WB
	Lower limit	10°C DB	-9°C DB -10°C WB
Voltage		198 – 264 V	

4. OUTLINE DIMENSIONS

4.1 Indoor Unit: Apha 7, 9 (Omega)

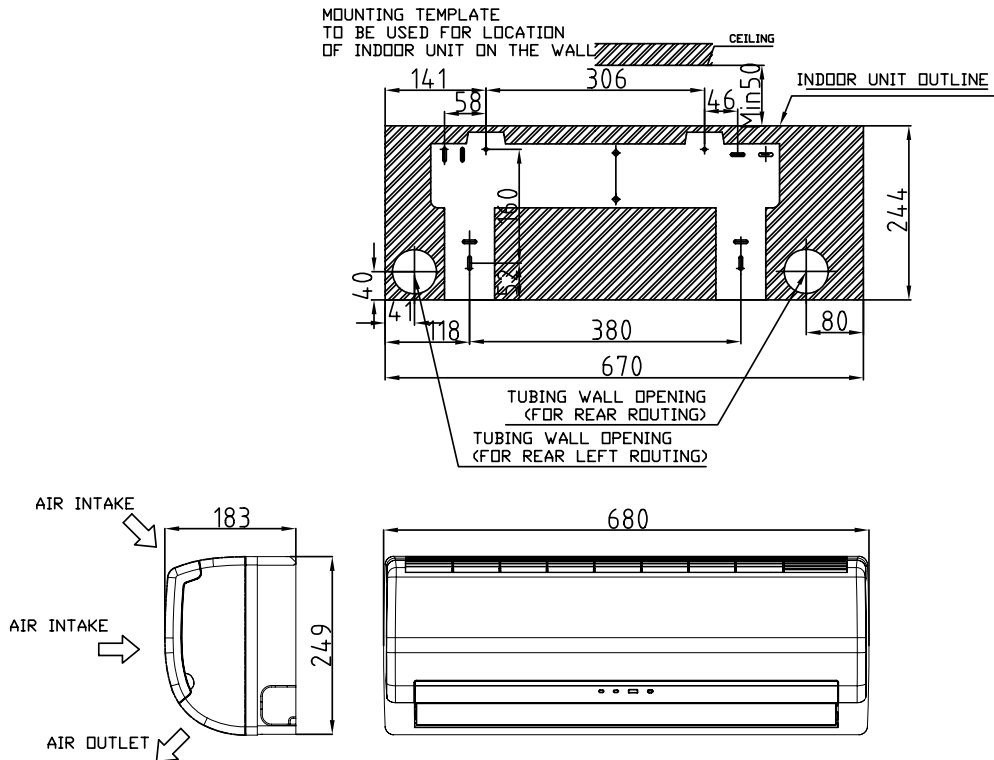

4.2 Indoor Unit: Alpha 12 (Omega)

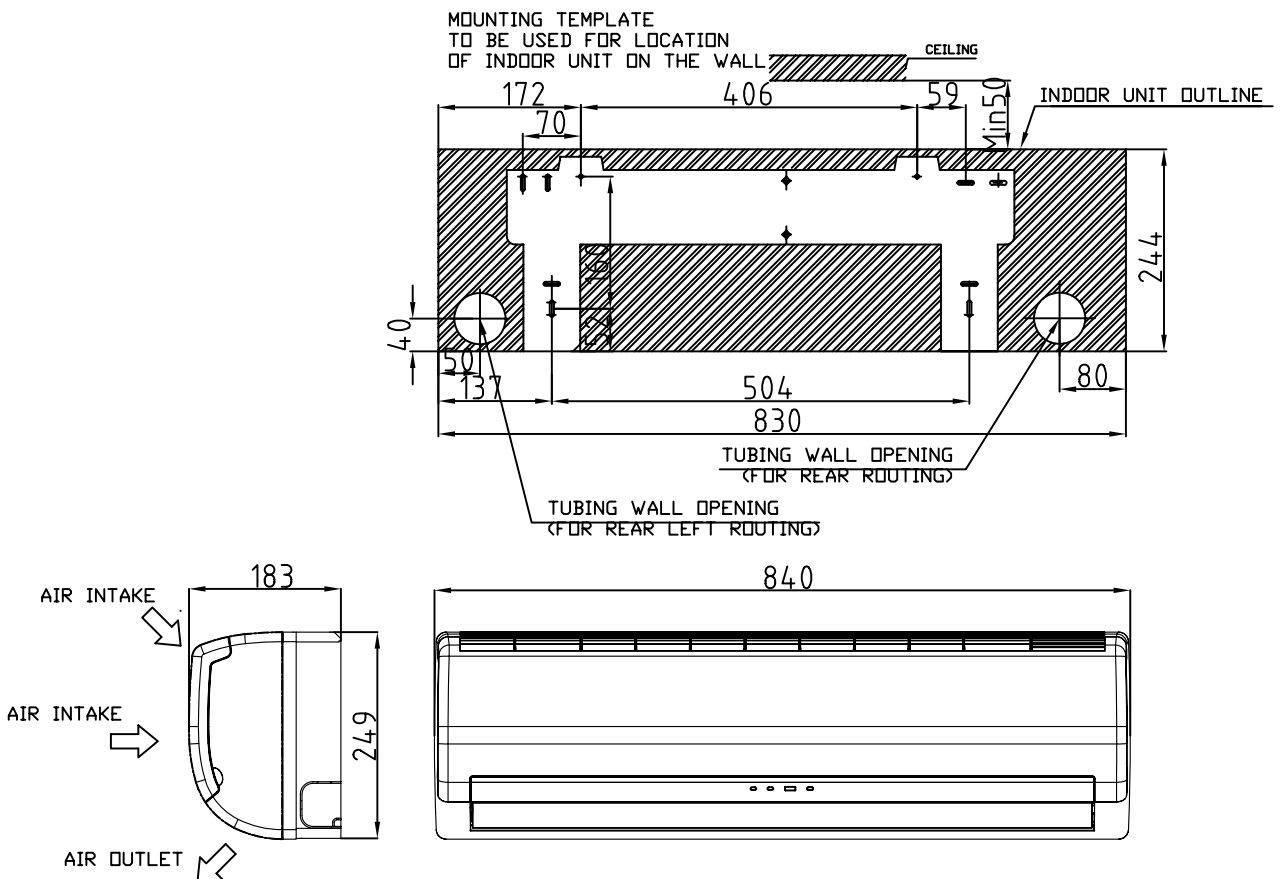

4.3 Indoor Unit: Alpha 17

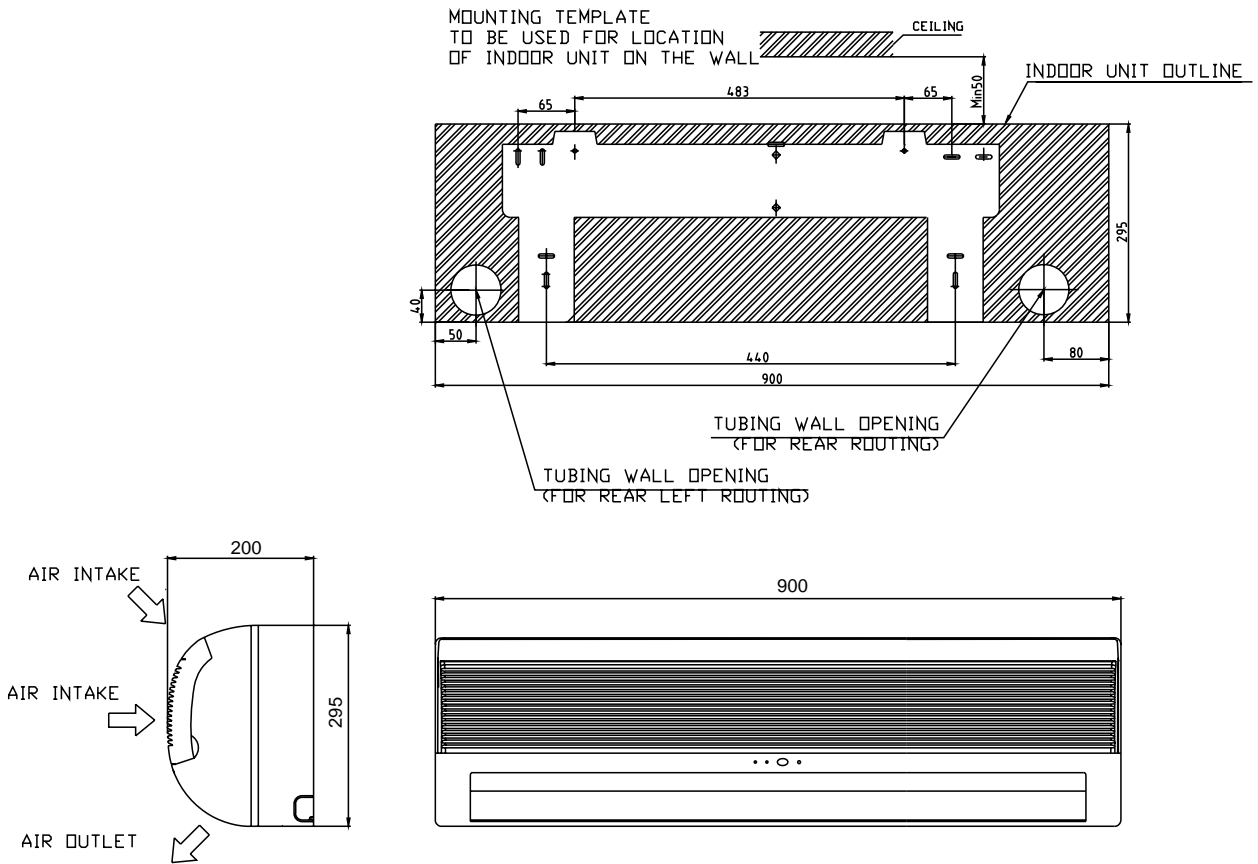

4.4 Indoor Unit: Alpha 9DF

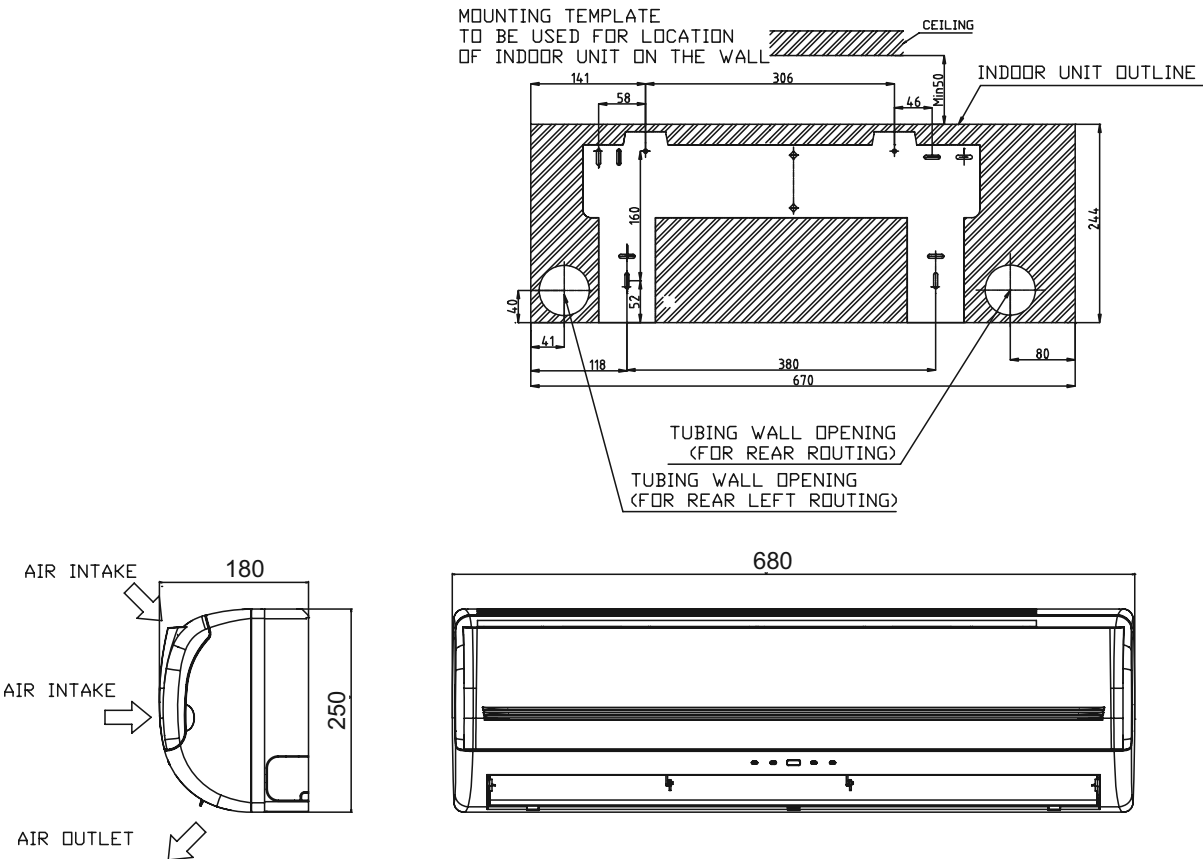

4.5 Indoor Unit: Alpha 12DF

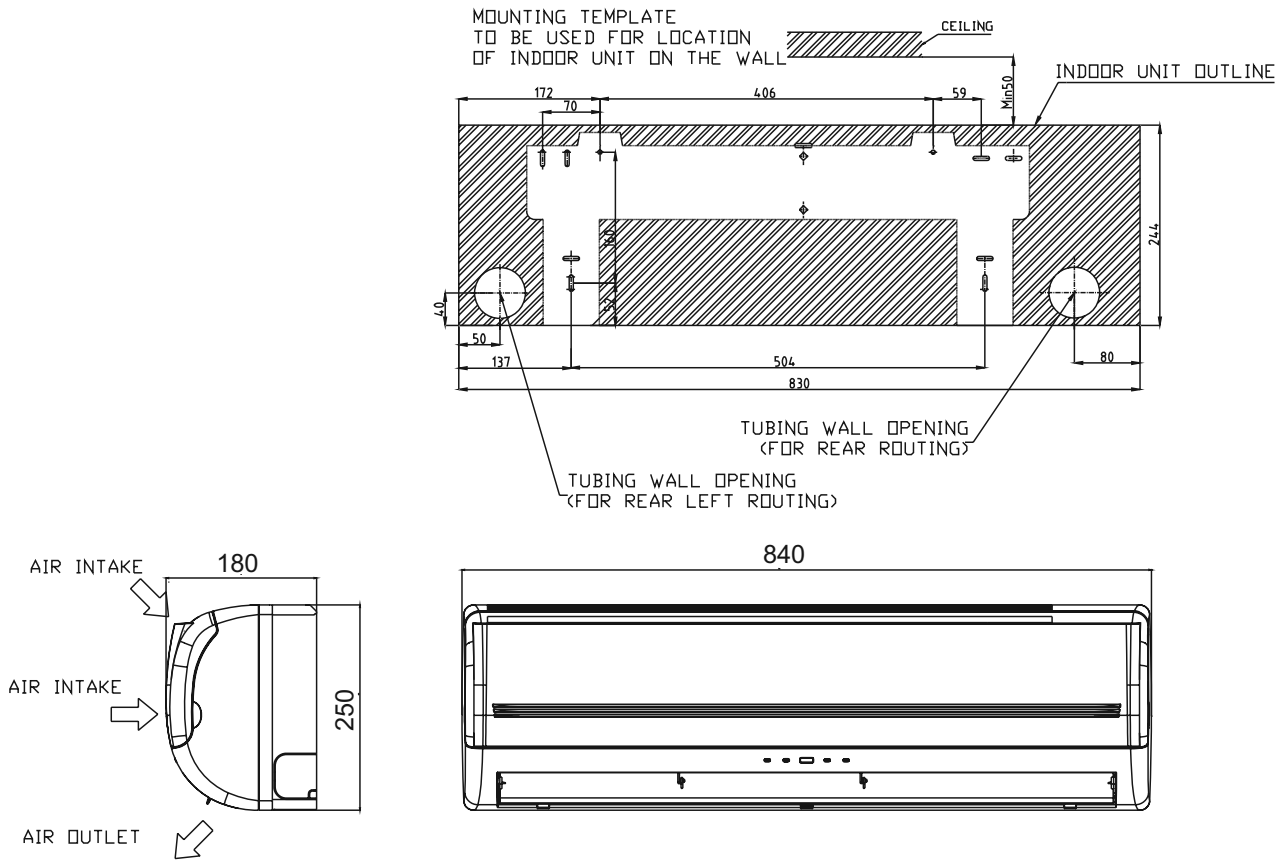

4.6 Indoor Unit: Delta 17F

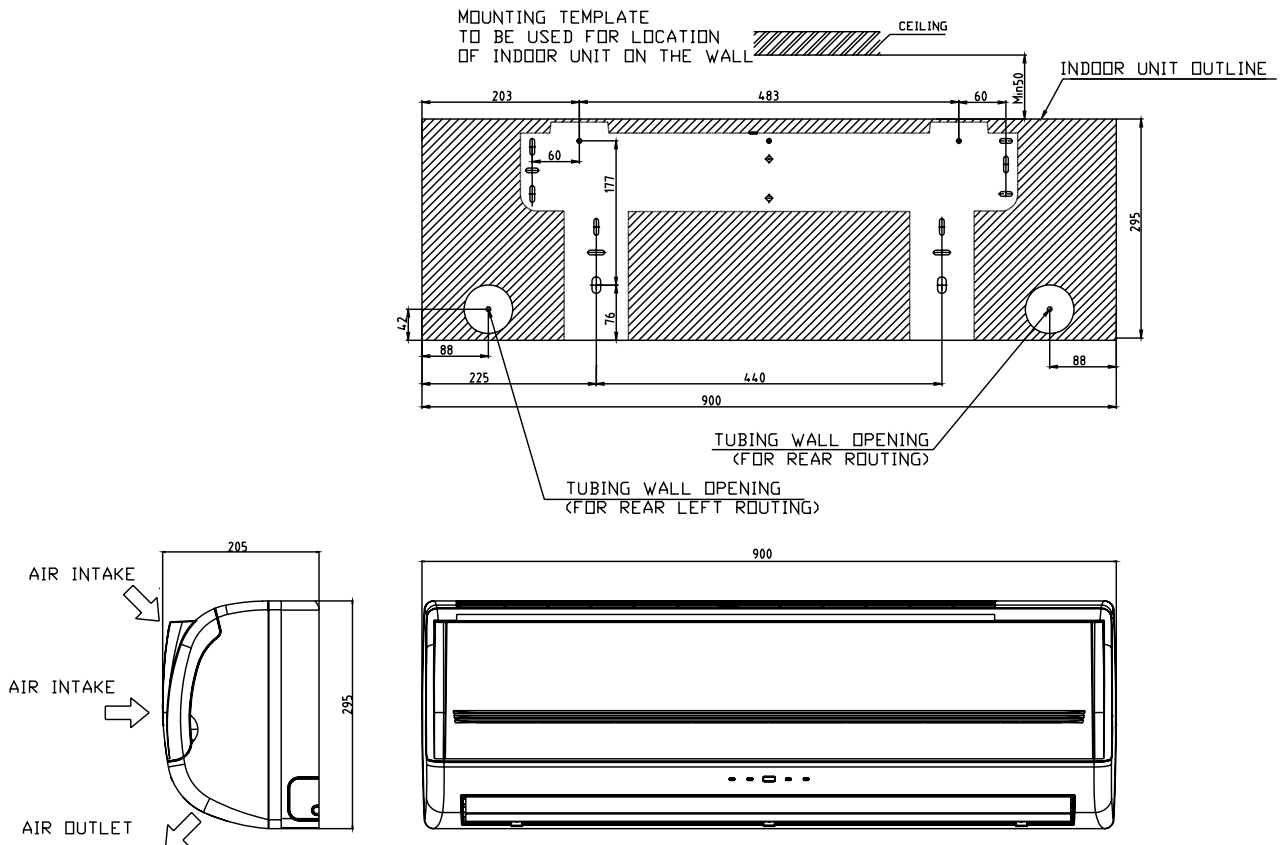

4.7 Indoor Unit: Delta 24F

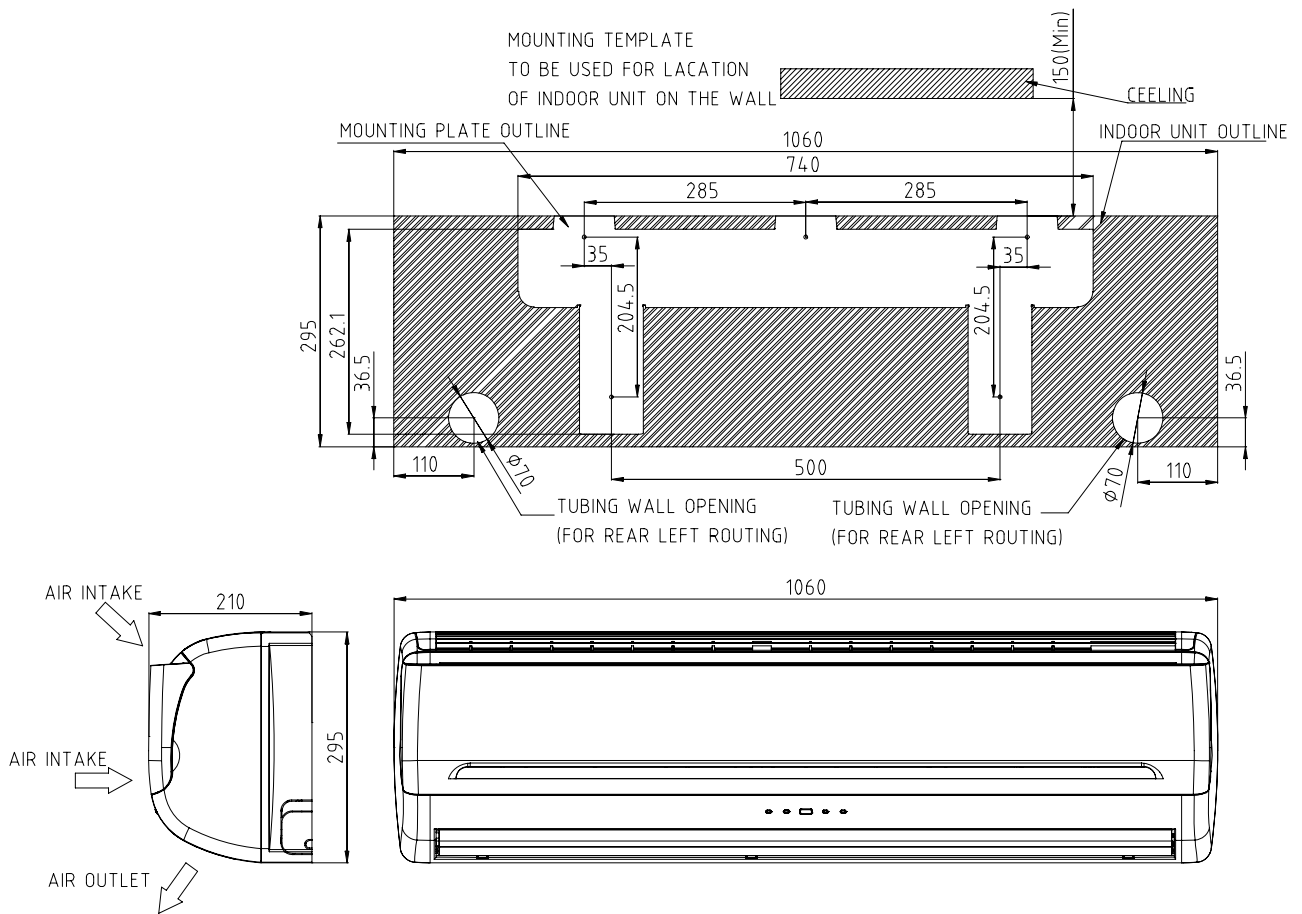

4.8 Outdoor Unit CON 7 (Alpha)

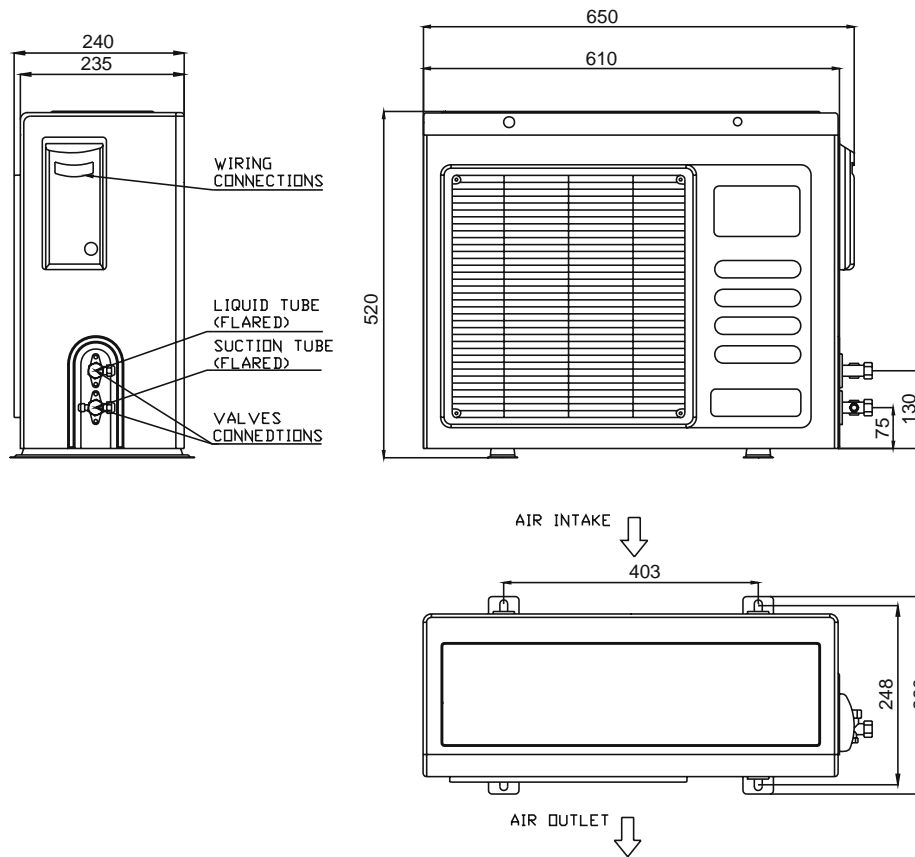

4.9 Outdoor Unit GCN 7, 9, 12 (Alpha)

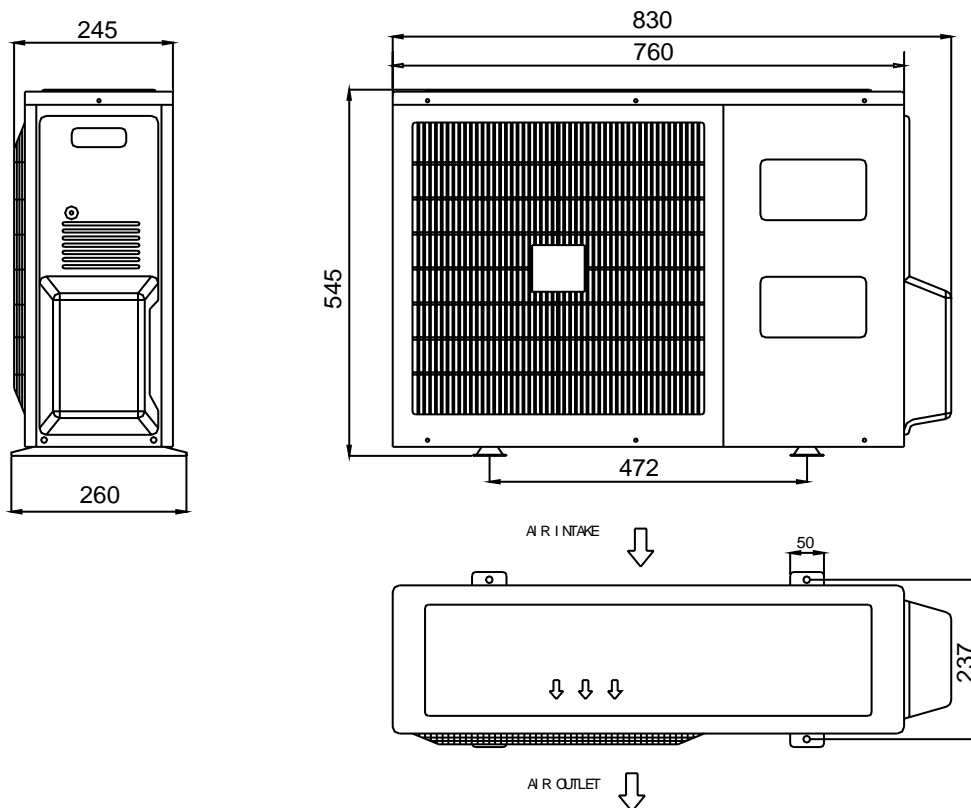

4.10 Outdoor Unit ONG3- 9, 12, 14, 17 (Alpha)

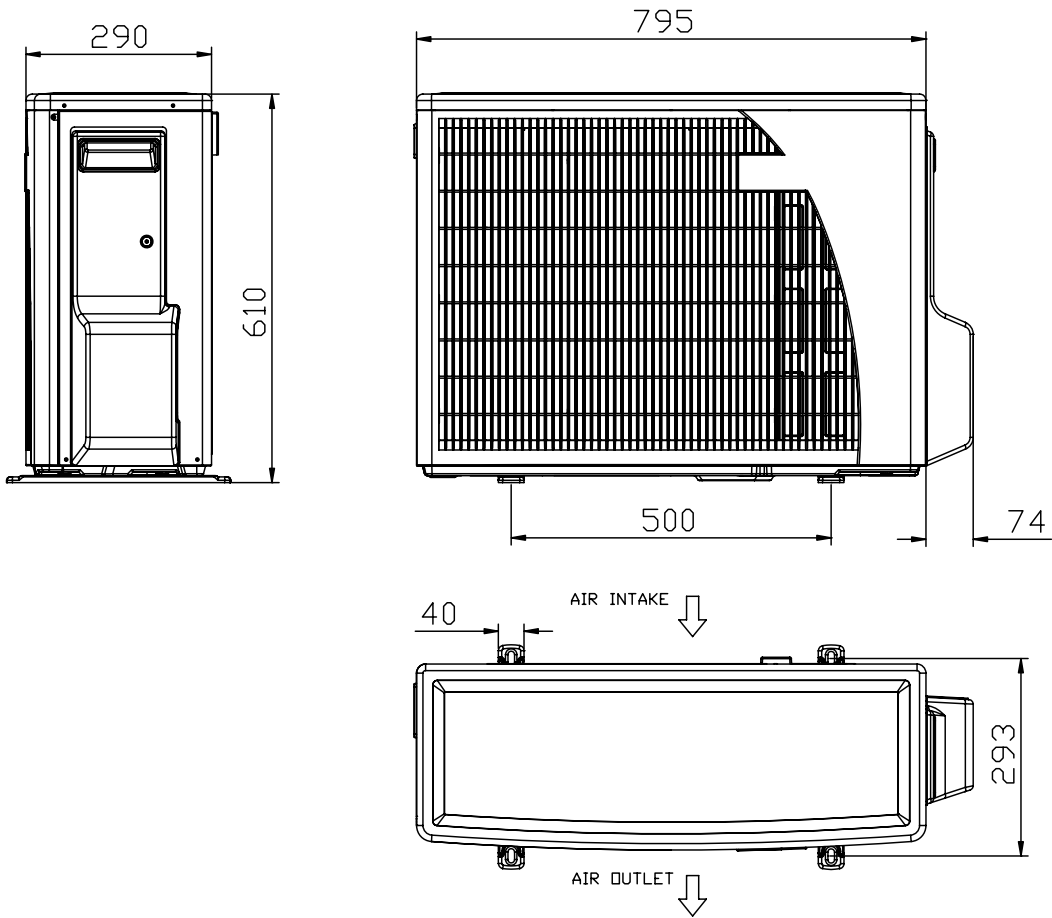

4.11 Outdoor Unit OU7-24C

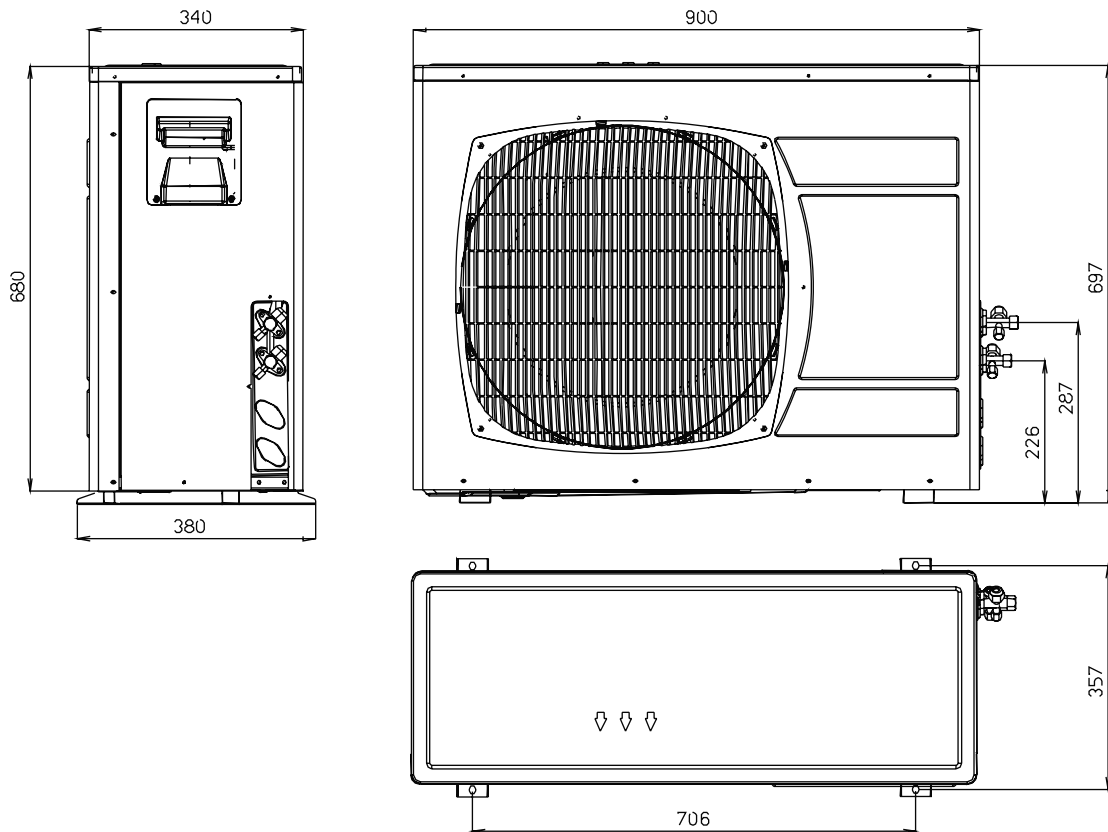

5. PERFORMANCE DATA & PRESSURE CURVES

5.1 Alpha7/CON7

5.1.1 Cooling Mode at 7.5m Tubing Connection.

230V : Indoor Fan at High Speed.

ENTERING AIR DB OD Coil(°C)	Data	ENTERING AIR WB/DB ID Coil(°C)				
		15/21	17/24	19/27	21/29	23/32
15 ⁽¹⁾	TC	2.16	2.24	2.29	2.34	2.38
	SC	1.49	1.55	1.61	1.65	1.68
	PI	0.48	0.48	0.48	0.49	0.49
20 ⁽¹⁾	TC	2.09	2.20	2.27	2.33	2.38
	SC	1.46	1.54	1.60	1.65	1.68
	PI	0.52	0.53	0.53	0.53	0.53
25	TC	1.98	2.14	2.25	2.31	2.37
	SC	1.42	1.51	1.59	1.64	1.67
	PI	0.57	0.57	0.57	0.58	0.58
30	TC	1.85	2.01	2.18	2.25	2.32
	SC	1.38	1.46	1.56	1.60	1.63
	PI	0.61	0.62	0.62	0.63	0.64
35	TC	1.71	1.86	2.05	2.15	2.25
	SC	1.31	1.40	1.52	1.56	1.59
	PI	0.66	0.67	0.68	0.69	0.69
40	TC	1.56	1.70	1.85	2.02	2.13
	SC	1.23	1.33	1.44	1.48	1.51
	PI	0.71	0.72	0.73	0.74	0.75
46	TC	1.35	1.48	1.62	1.79	1.93
	SC	1.14	1.22	1.31	1.36	1.39
	PI	0.78	0.79	0.81	0.82	0.83

LEGEND

- TC – Total Cooling Capacity, kW
- SC – Sensible Capacity, kW
- PI – Power Input, kW
- WB – Wet Bulb Temp., (°C)
- DB – Dry Bulb Temp., (°C)
- ID – Indoor
- OD – Outdoor

(1) Marked area is below standard operating limits. For operating in low ambient conditions, an A.S.K Kit is required.

5.1.2 Heating

ENTERING WB OD COIL(°C)	ENTERING AIR DB ID COIL(°C)					
	15		20		25	
	TH	PI	TH	PI	TH	PI
-10	1.13	0.50	1.09	0.54	1.04	0.56
-7	1.21	0.52	1.17	0.54	1.13	0.57
-2	1.29	0.52	1.25	0.55	1.20	0.59
2	1.57	0.55	1.51	0.58	1.44	0.62
6	2.21	0.59	2.15	0.63	2.07	0.67
10	2.41	0.62	2.34	0.66	2.28	0.71
15	2.60	0.65	2.54	0.70	2.47	0.74
20	2.74	0.67	2.68	0.72	2.60	0.78

LEGEND

- TH – Total Heating Capacity, kW
- PI – Power Input, kW
- WB – Wet Bulb Temp., (°C)
- DB – Dry Bulb Temp., (°C)
- ID – Indoor
- OD – Outdoor

5.2 Model: Alpha7/CON7

5.2.1 Cooling

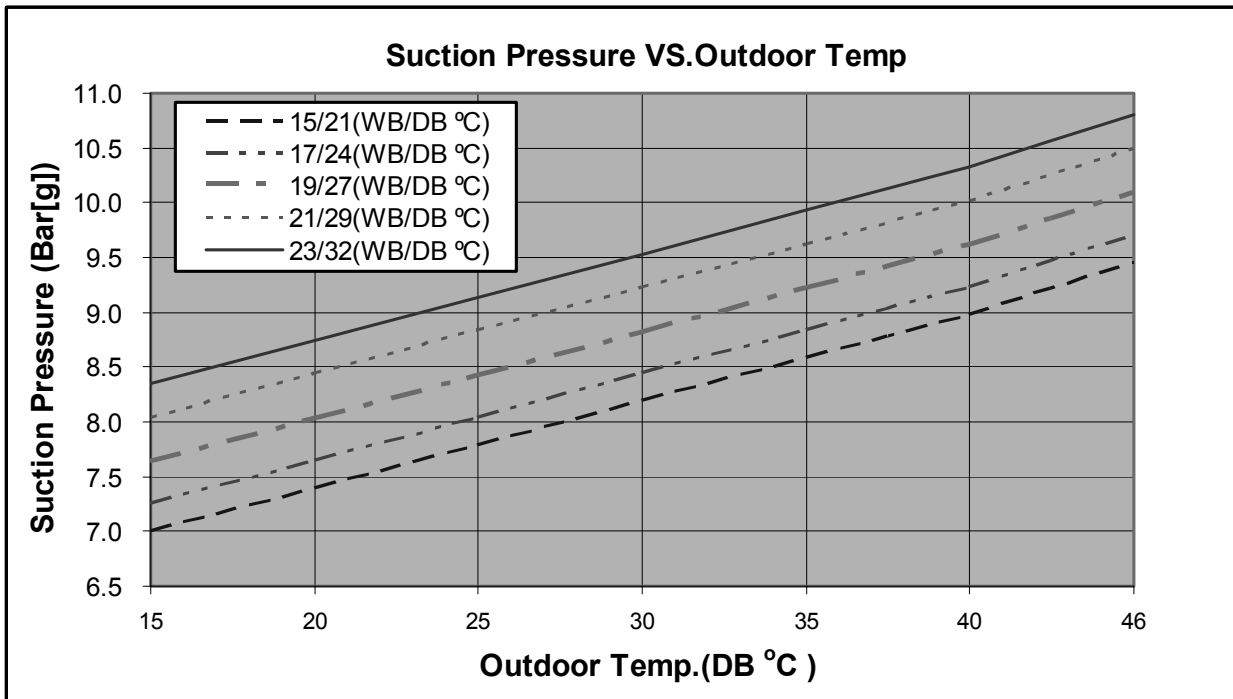
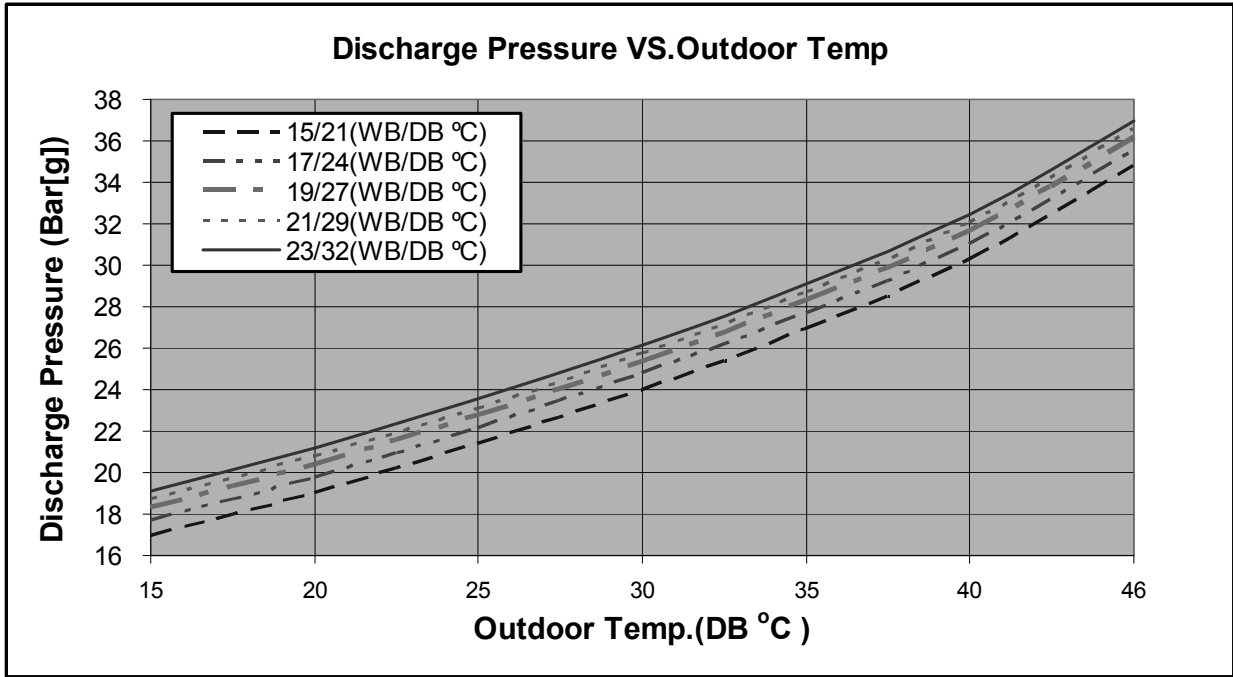

5.2.2 Heating

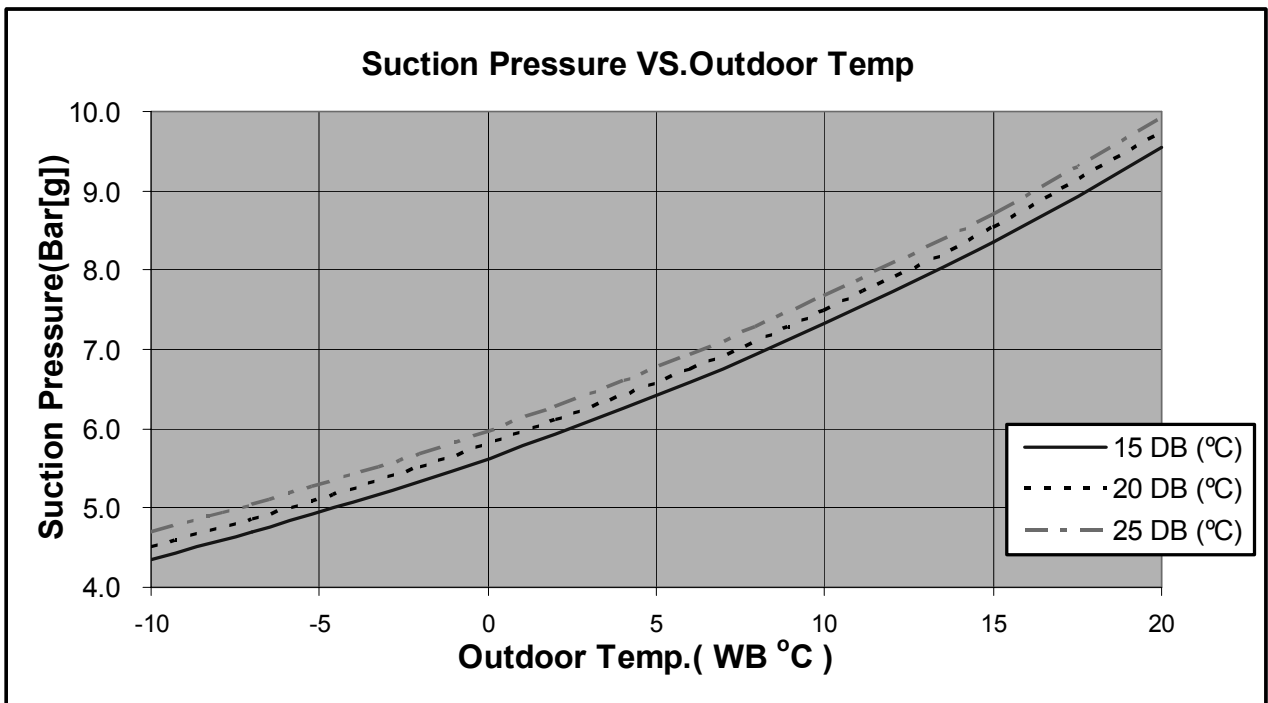
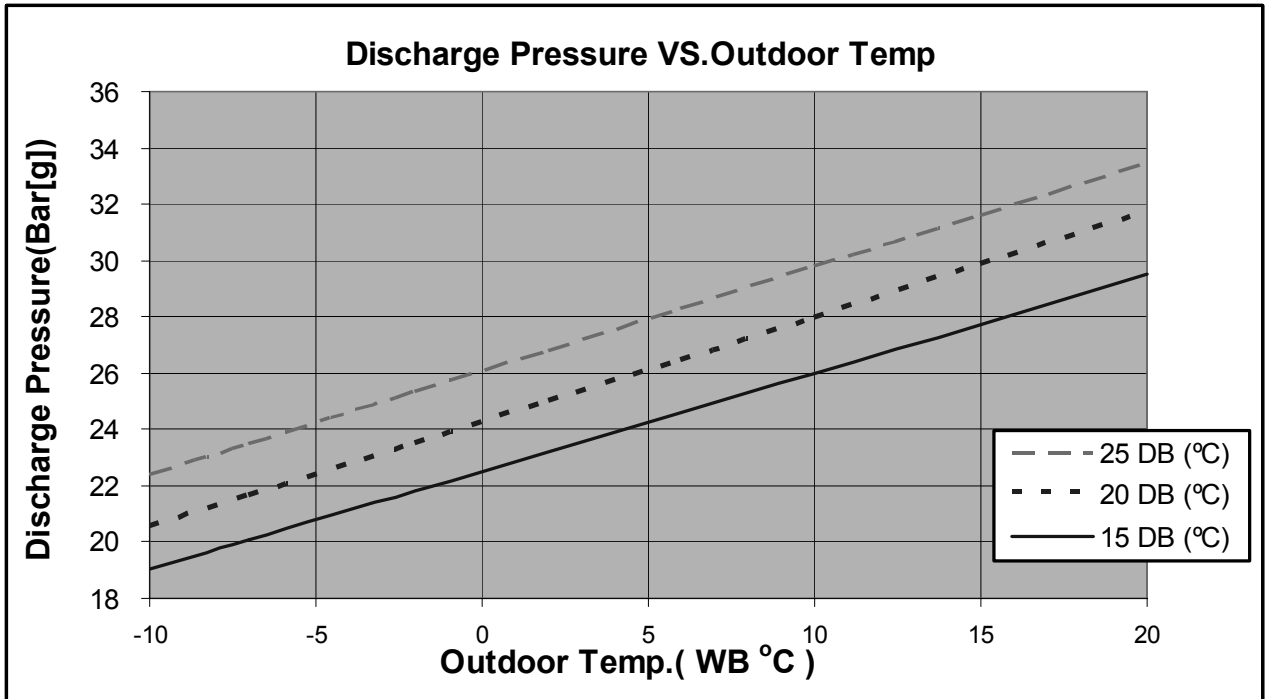

5.3 Alpha7 DF / GCN7 RC R410A A2

5.3.1 Cooling Mode at 7.5m Tubing Connection.

230V : Indoor Fan at High Speed.

Entering Air DB OD Coil(°C)	Data	Entering Air WB/DB ID Coil(°C)				
		15/21	17/24	19/27	21/29	23/32
15	TC	2.40	2.49	2.55	2.61	2.65
	SC	1.67	1.74	1.81	1.85	1.89
	PI	0.44	0.44	0.44	0.44	0.44
20	TC	2.33	2.45	2.53	2.59	2.64
	SC	1.64	1.73	1.80	1.85	1.88
	PI	0.48	0.48	0.48	0.48	0.48
25	TC	2.20	2.38	2.50	2.57	2.64
	SC	1.59	1.69	1.78	1.84	1.87
	PI	0.52	0.52	0.52	0.53	0.53
30	TC	2.06	2.24	2.42	2.51	2.58
	SC	1.54	1.64	1.75	1.80	1.83
	PI	0.56	0.56	0.57	0.57	0.58
35	TC	1.90	2.07	2.28	2.39	2.51
	SC	1.47	1.57	1.71	1.75	1.79
	PI	0.60	0.61	0.62	0.62	0.63
40	TC	1.73	1.89	2.06	2.25	2.37
	SC	1.38	1.49	1.61	1.66	1.70
	PI	0.65	0.66	0.67	0.68	0.68
46	TC	1.50	1.64	1.81	2.00	2.15
	SC	1.28	1.37	1.47	1.52	1.56
	PI	0.71	0.72	0.73	0.74	0.75

LEGEND

- TC – Total Cooling Capacity, kW
- SC – Sensible Capacity, kW
- PI – Power Input, kW
- WB – Wet Bulb Temp., (°C)
- DB – Dry Bulb Temp., (°C)
- ID – Indoor
- OD – Outdoor

(1) Marked area is below standard operating limits. For operating in low ambient conditions, an A.S.K Kit is required.

5.3.2 Heating

ENTERING WB OD COIL(°C)	ENTERING AIR DB ID COIL(°C)					
	15		20		25	
	TH	PI	TH	PI	TH	PI
-10	1.21	0.54	1.16	0.57	1.12	0.60
-7	1.30	0.55	1.25	0.58	1.21	0.61
-2	1.38	0.56	1.33	0.59	1.29	0.62
2	1.68	0.58	1.61	0.62	1.54	0.66
6	2.37	0.63	2.30	0.67	2.22	0.71
10	2.58	0.66	2.51	0.71	2.44	0.76
15	2.78	0.69	2.71	0.74	2.65	0.79
20	2.93	0.71	2.86	0.77	2.78	0.83

LEGEND

- TH – Total Heating Capacity, kW
- PI – Power Input, kW
- WB – Wet Bulb Temp., (°C)
- DB – Dry Bulb Temp., (°C)
- ID – Indoor
- OD – Outdoor

5.4 Alpha7 DF / GCN7 RC R410A A2

5.4.1 Cooling

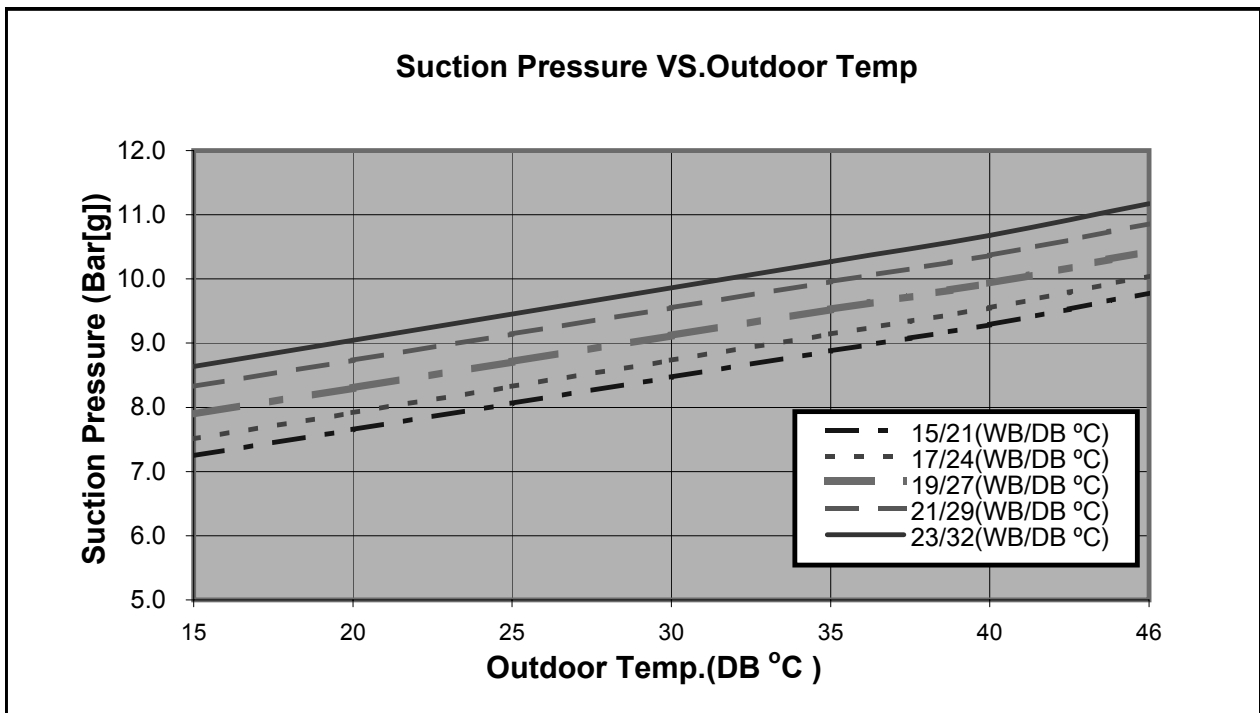
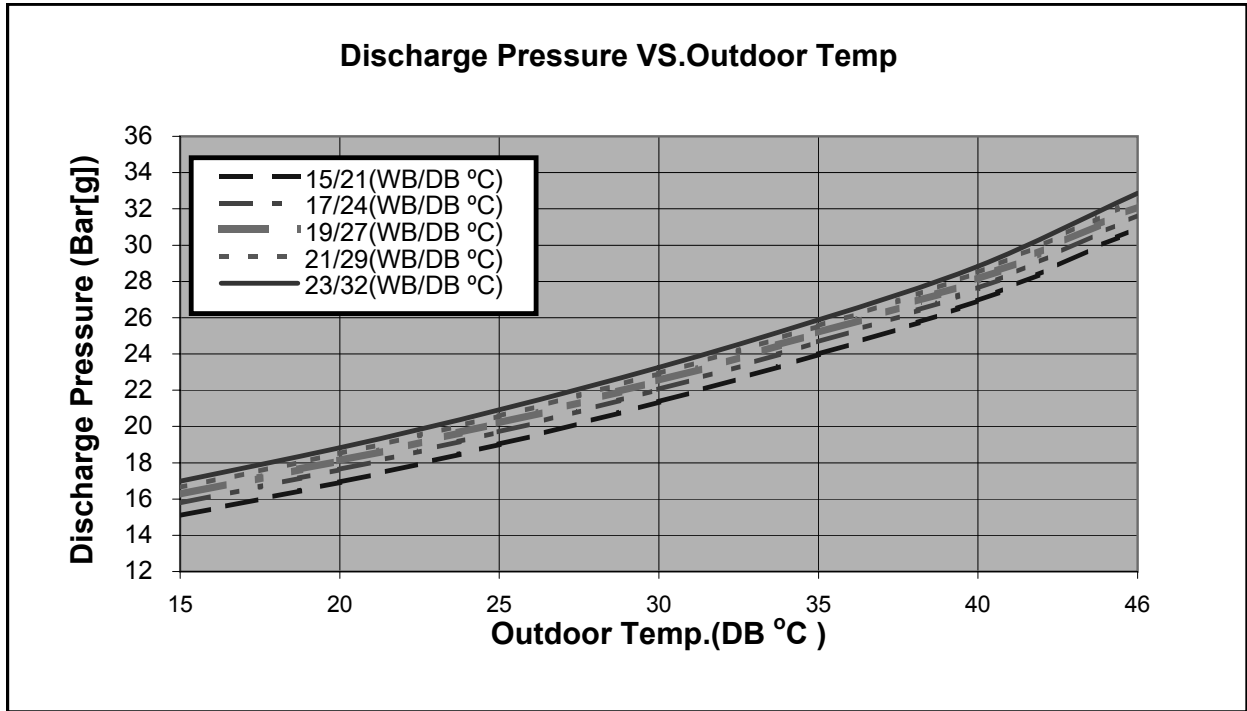

5.4.2 Heating

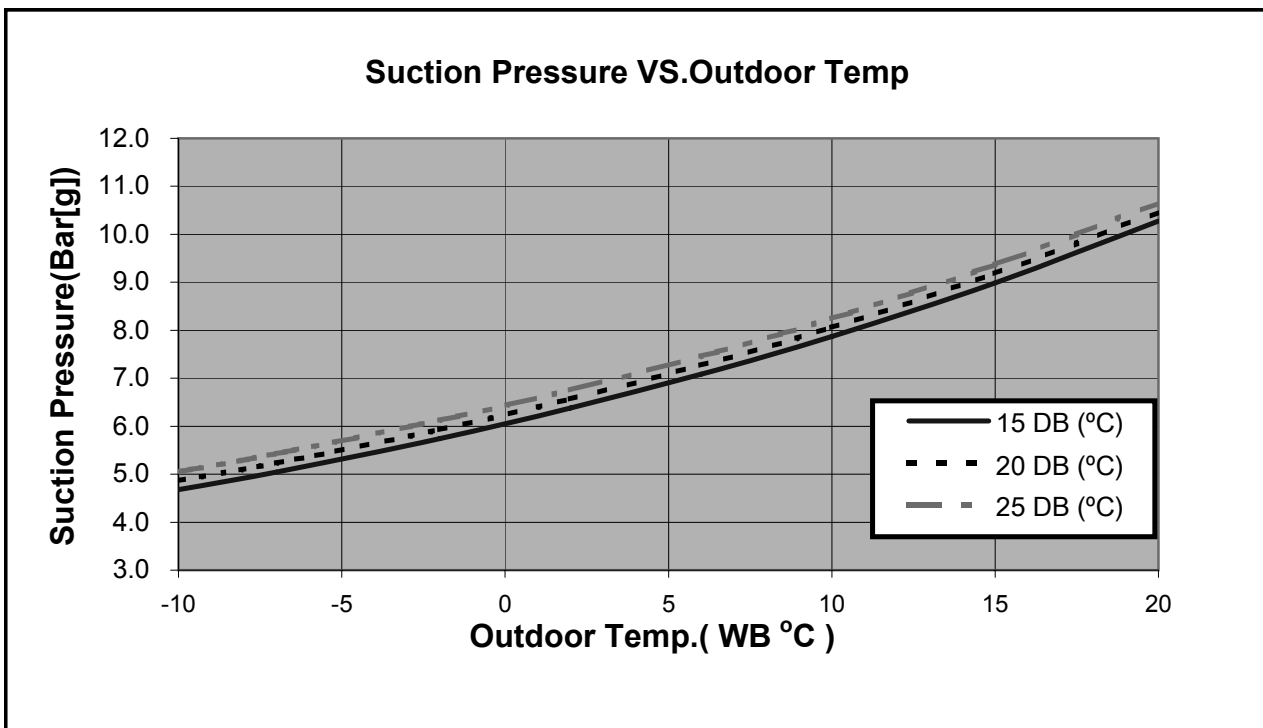
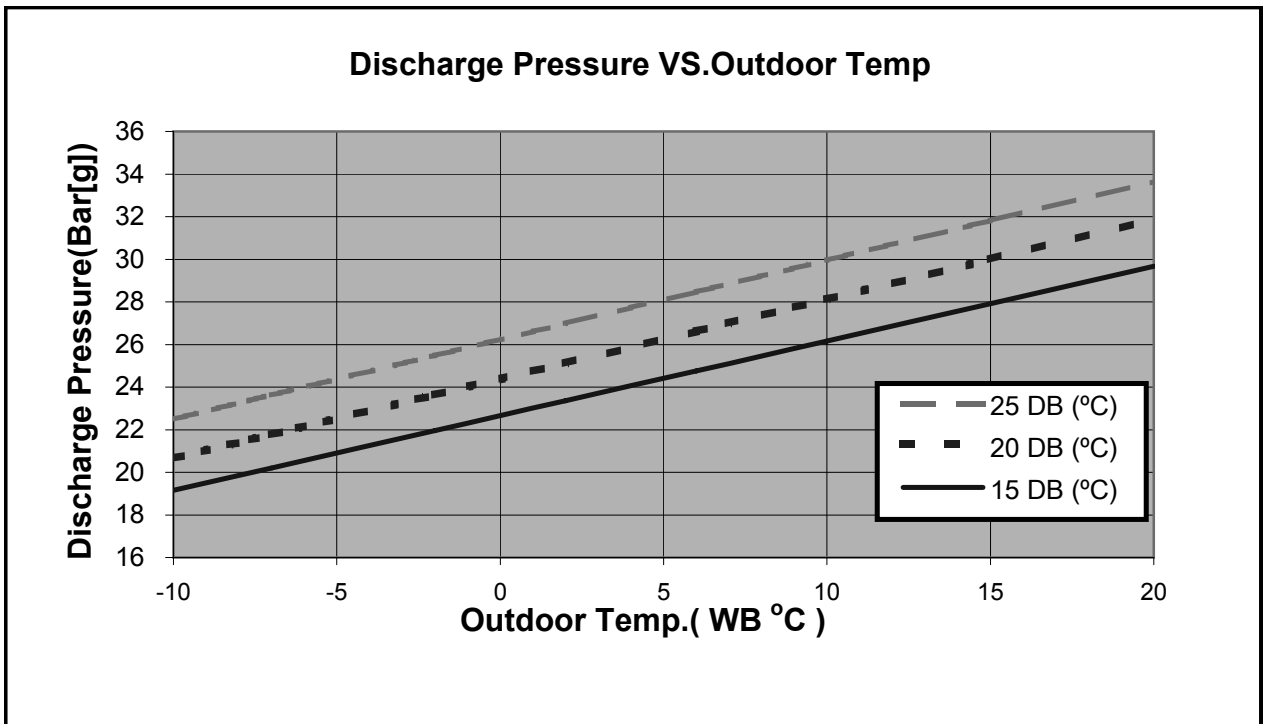

5.5 Alpha9 / GCN9

5.5.1 Cooling Mode at 7.5m Tubing Connection.

230V : Indoor Fan at High Speed.

ENTERING AIR DB OD Coil(°C)	Data	ENTERING AIR WB/DB ID Coil(°C)				
		15/21	17/24	19/27	21/29	23/32
15 ⁽¹⁾	TC	2.78	2.88	2.95	3.02	3.07
	SC	1.78	1.86	1.93	1.98	2.02
	PI	0.62	0.62	0.62	0.62	0.62
20 ⁽¹⁾	TC	2.69	2.84	2.93	3.00	3.06
	SC	1.75	1.84	1.92	1.97	2.01
	PI	0.67	0.67	0.67	0.68	0.68
25	TC	2.55	2.75	2.89	2.98	3.05
	SC	1.70	1.81	1.90	1.96	2.00
	PI	0.72	0.73	0.73	0.74	0.74
30	TC	2.38	2.59	2.80	2.90	2.99
	SC	1.65	1.75	1.86	1.92	1.95
	PI	0.78	0.79	0.80	0.81	0.81
35	TC	2.21	2.39	2.64	2.77	2.90
	SC	1.57	1.68	1.82	1.87	1.91
	PI	0.84	0.86	0.87	0.88	0.88
40	TC	2.01	2.18	2.38	2.60	2.74
	SC	1.48	1.59	1.72	1.78	1.81
	PI	0.91	0.92	0.94	0.95	0.96
46	TC	1.74	1.90	2.09	2.31	2.49
	SC	1.36	1.46	1.57	1.62	1.66
	PI	0.99	1.01	1.03	1.04	1.06

LEGEND

- TC – Total Cooling Capacity, kW
- SC – Sensible Capacity, kW
- PI – Power Input, kW
- WB – Wet Bulb Temp., (°C)
- DB – Dry Bulb Temp., (°C)
- ID – Indoor
- OD – Outdoor

(1) Marked area is below standard operating limits. For operating in low ambient conditions, an A.S.K Kit is required.

5.5.2 Heating

ENTERING WB OD COIL(°C)	ENTERING AIR DB ID COIL(°C)					
	15		20		25	
	TH	PI	TH	PI	TH	PI
-10	1.49	0.74	1.43	0.79	1.37	0.83
-7	1.60	0.76	1.54	0.80	1.49	0.85
-2	1.70	0.77	1.64	0.82	1.58	0.86
2	2.07	0.81	1.98	0.86	1.90	0.91
6	2.91	0.87	2.83	0.93	2.73	0.99
10	3.17	0.92	3.08	0.98	3.00	1.05
15	3.42	0.96	3.34	1.03	3.25	1.10
20	3.61	0.99	3.52	1.07	3.42	1.15

LEGENDw

- TH – Total Heating Capacity, kW
- PI – Power Input, kW
- WB – Wet Bulb Temp., (°C)
- DB – Dry Bulb Temp., (°C)
- ID – Indoor
- OD – Outdoor

5.6 Model: Alpha9 / GCN9

5.6.1 Cooling

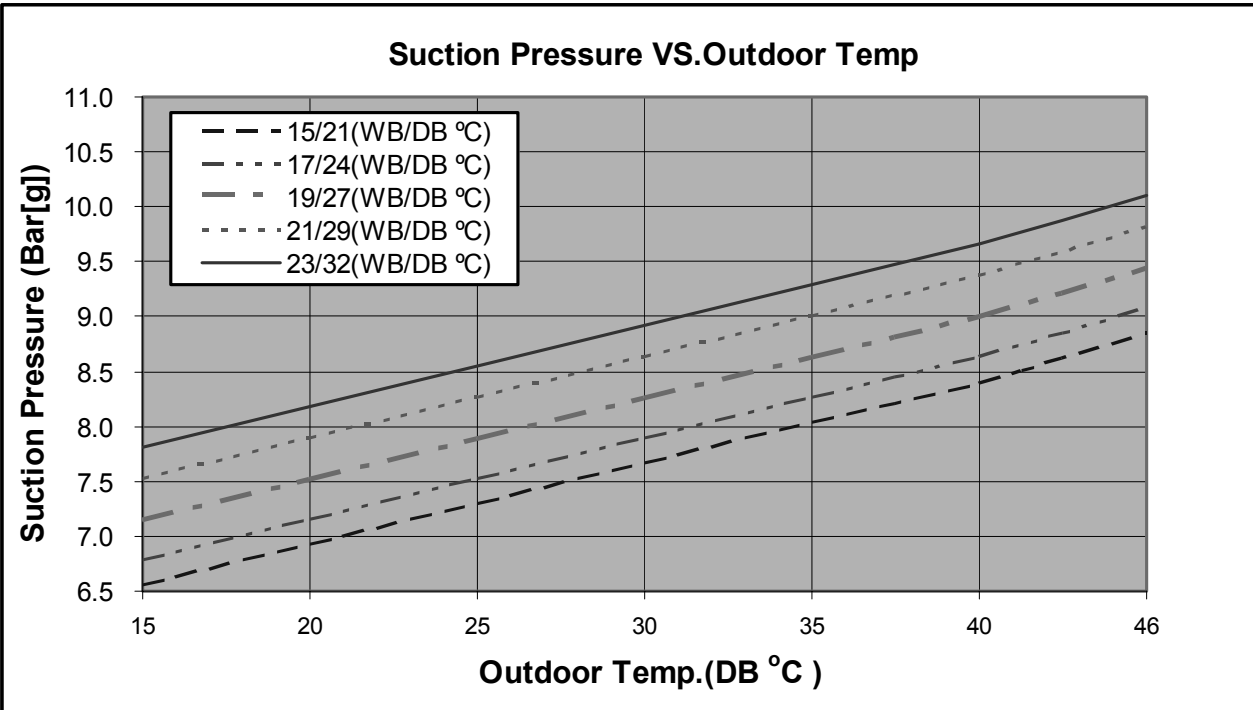
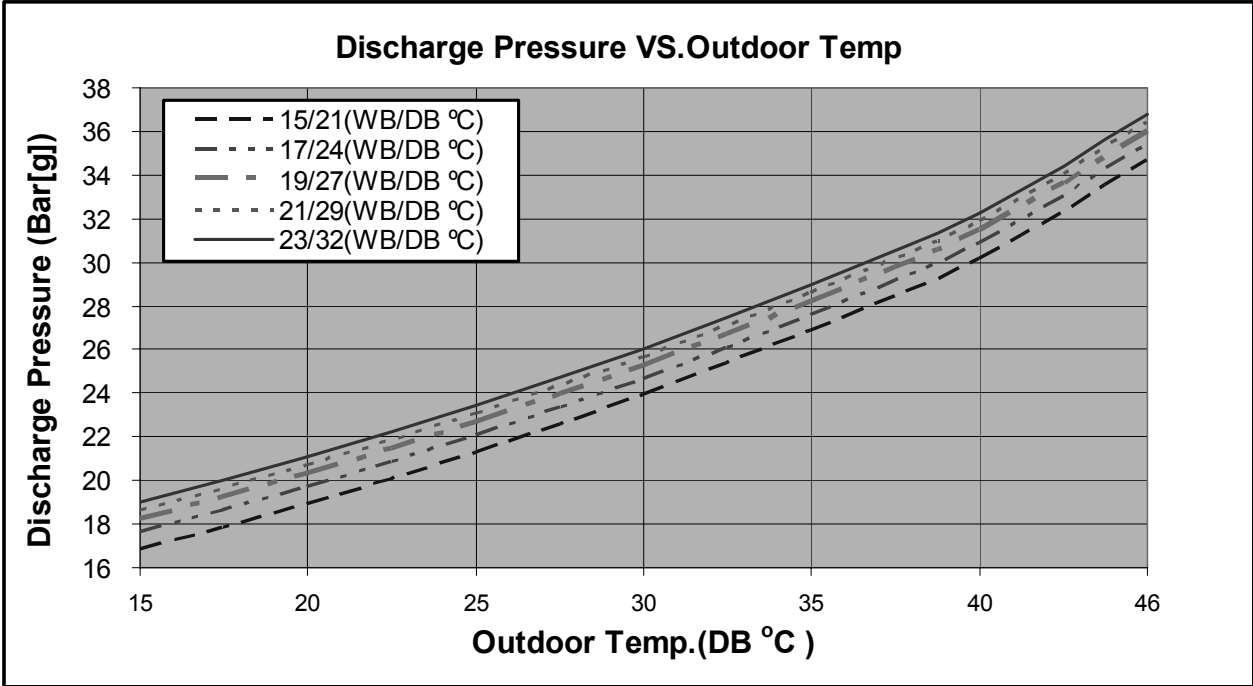

5.6.2 Heating

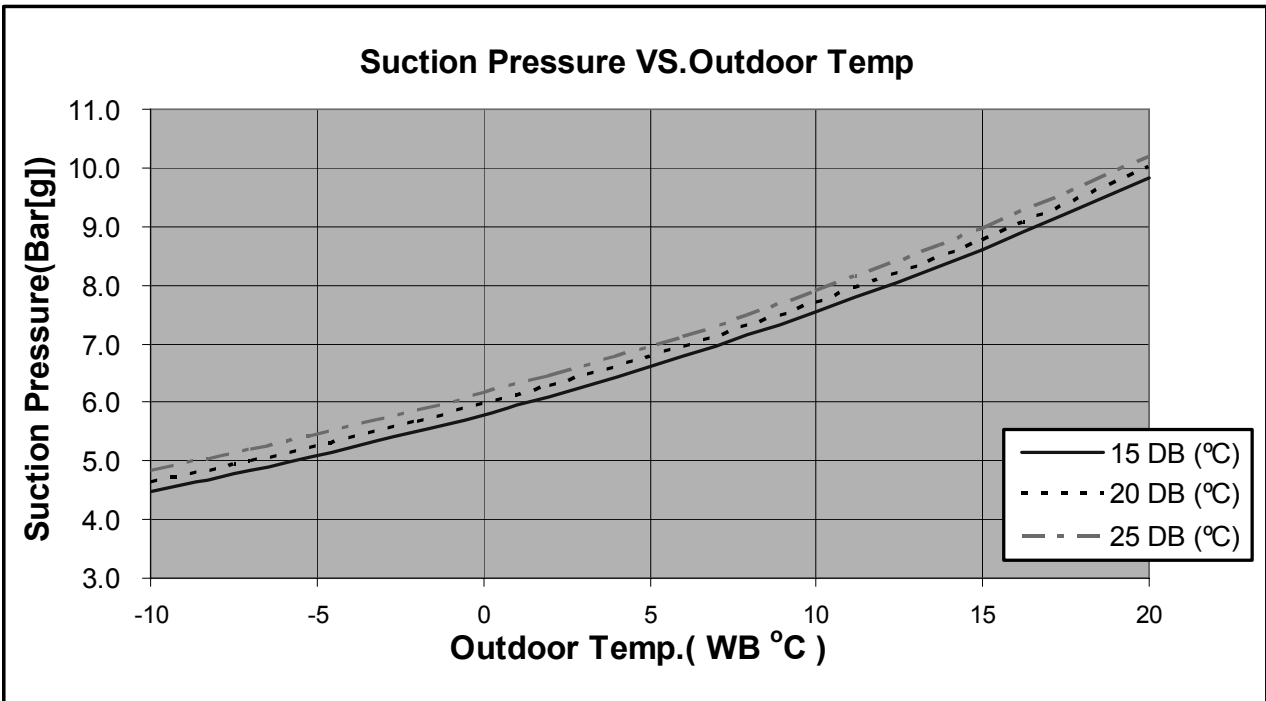
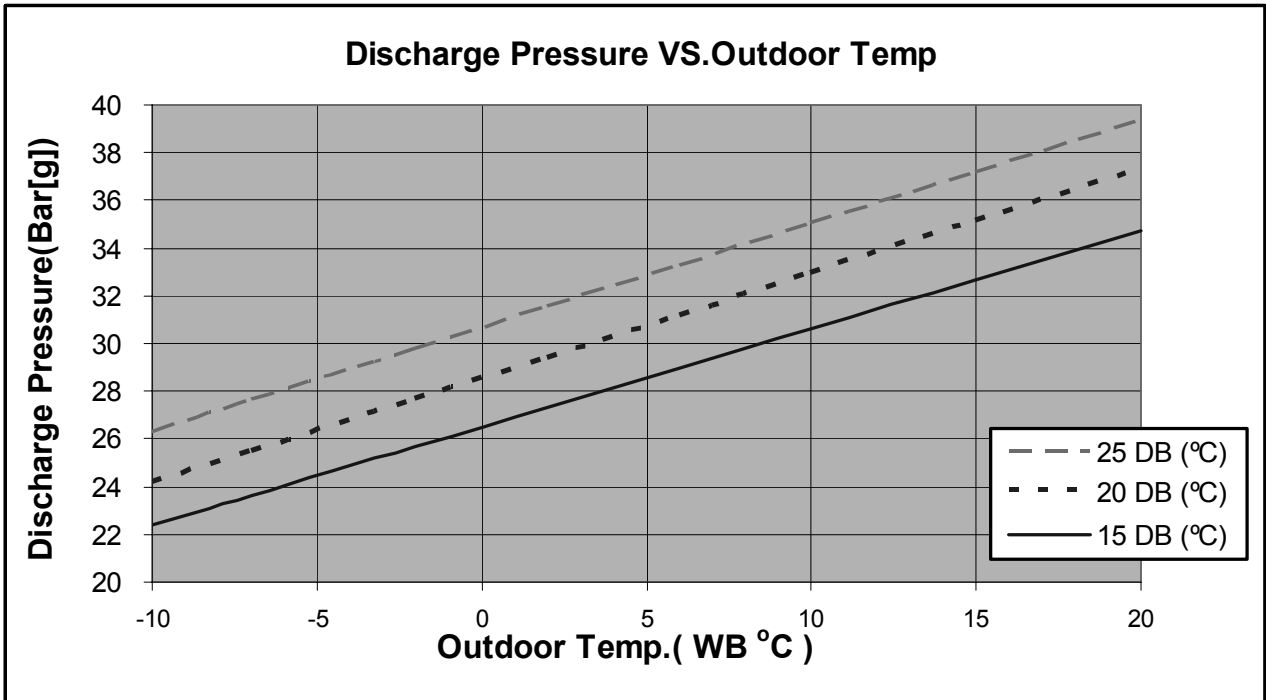

5.7 Alpha9 DF / ONG3-9 RC R410A B2

5.7.1 Cooling Mode at 7.5m Tubing Connection.

230V : Indoor Fan at High Speed.

Entering Air DB OD Coil(°C)	Data	Entering Air WB/DB ID Coil(°C)				
		15/21	17/24	19/27	21/29	23/32
15	TC	2.85	2.95	3.02	3.09	3.14
	SC	1.82	1.90	1.97	2.02	2.06
	PI	0.53	0.53	0.53	0.54	0.54
20	TC	2.75	2.90	2.99	3.06	3.13
	SC	1.79	1.88	1.96	2.02	2.05
	PI	0.58	0.58	0.58	0.58	0.59
25	TC	2.61	2.81	2.96	3.05	3.12
	SC	1.74	1.85	1.95	2.00	2.04
	PI	0.62	0.63	0.63	0.64	0.64
30	TC	2.44	2.65	2.87	2.97	3.06
	SC	1.68	1.79	1.90	1.96	2.00
	PI	0.67	0.68	0.69	0.69	0.70
35	TC	2.26	2.45	2.70	2.84	2.97
	SC	1.60	1.72	1.86	1.91	1.95
	PI	0.73	0.74	0.75	0.76	0.76
40	TC	2.05	2.23	2.44	2.66	2.80
	SC	1.51	1.63	1.76	1.82	1.85
	PI	0.78	0.80	0.81	0.82	0.83
46	TC	1.78	1.95	2.14	2.36	2.55
	SC	1.39	1.49	1.60	1.66	1.70
	PI	0.86	0.87	0.89	0.90	0.91

LEGEND

- TC – Total Cooling Capacity, kW
- SC – Sensible Capacity, kW
- PI – Power Input, kW
- WB – Wet Bulb Temp., (°C)
- DB – Dry Bulb Temp., (°C)
- ID – Indoor
- OD – Outdoor

(1) Marked area is below standard operating limits. For operating in low ambient conditions, an A.S.K Kit is required.

5.7.2 Heating

ENTERING WB OD COIL(°C)	ENTERING AIR DB ID COIL(°C)					
	15		20		25	
	TH	PI	TH	PI	TH	PI
-10	1.52	0.66	1.46	0.71	1.41	0.74
-7	1.64	0.68	1.58	0.72	1.52	0.76
-2	1.74	0.69	1.68	0.73	1.62	0.77
2	2.12	0.72	2.03	0.77	1.94	0.81
6	2.99	0.78	2.90	0.83	2.80	0.88
10	3.25	0.82	3.16	0.88	3.07	0.94
15	3.51	0.85	3.42	0.92	3.34	0.98
20	3.70	0.88	3.61	0.95	3.51	1.03

LEGEND

- TH – Total Heating Capacity, kW
- PI – Power Input, kW
- WB – Wet Bulb Temp., (°C)
- DB – Dry Bulb Temp., (°C)
- ID – Indoor
- OD – Outdoor

5.8 Alpha9 DF / ONG3-9 RC R410A B2

5.8.1 Cooling

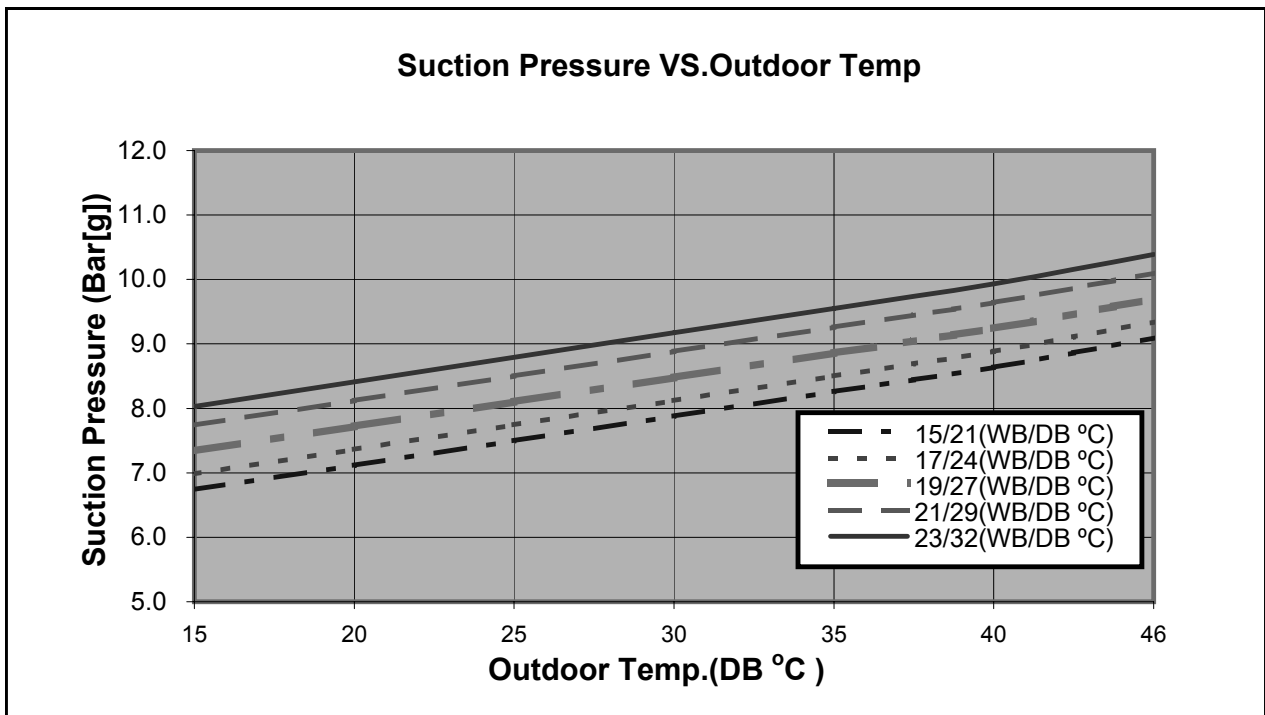
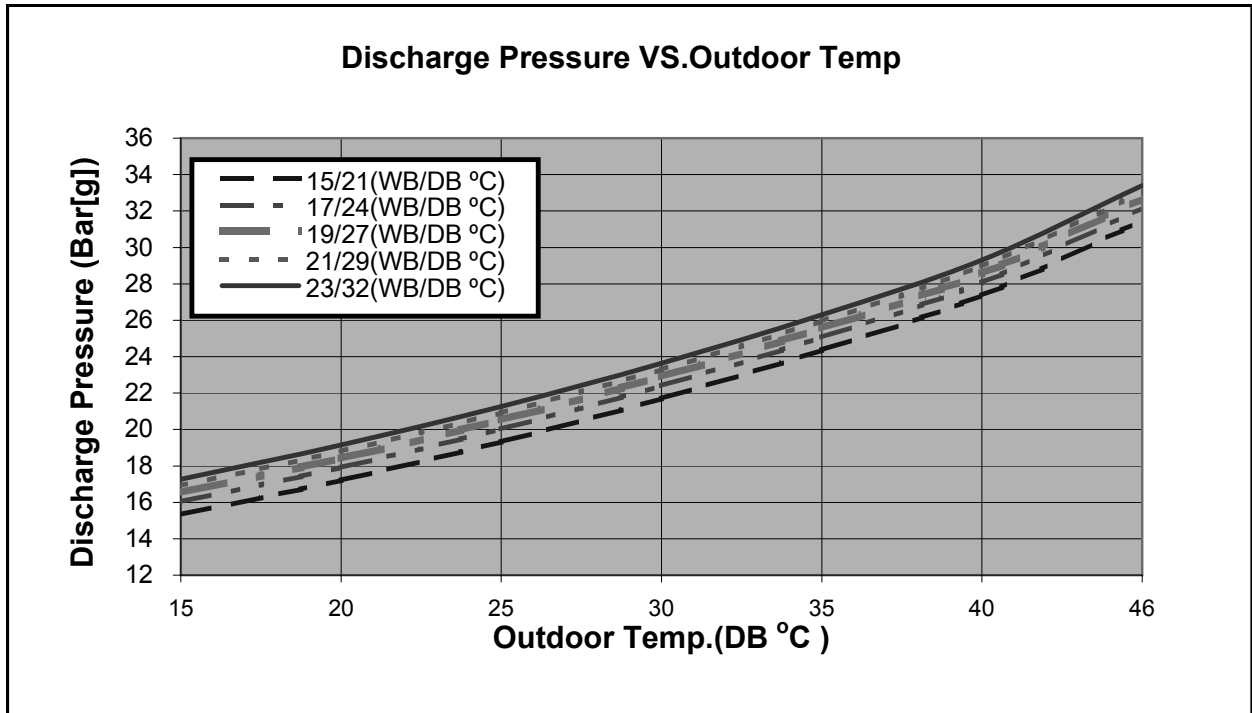

5.8.2 Heating

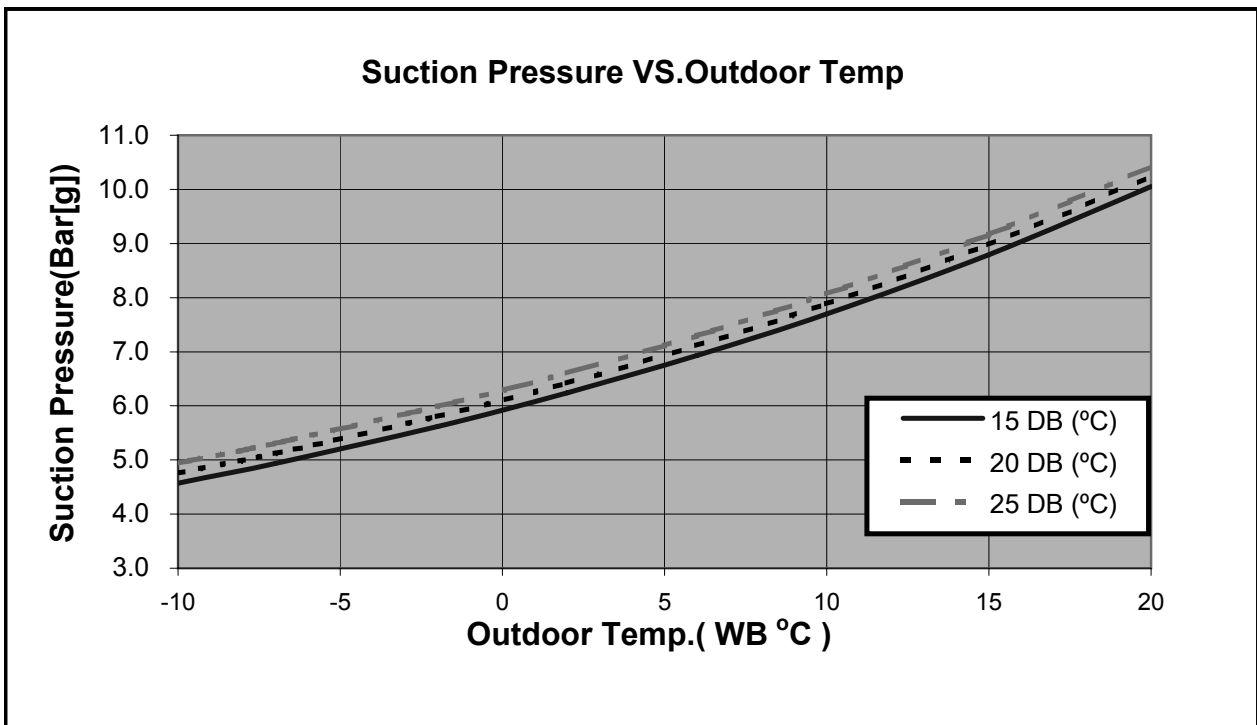
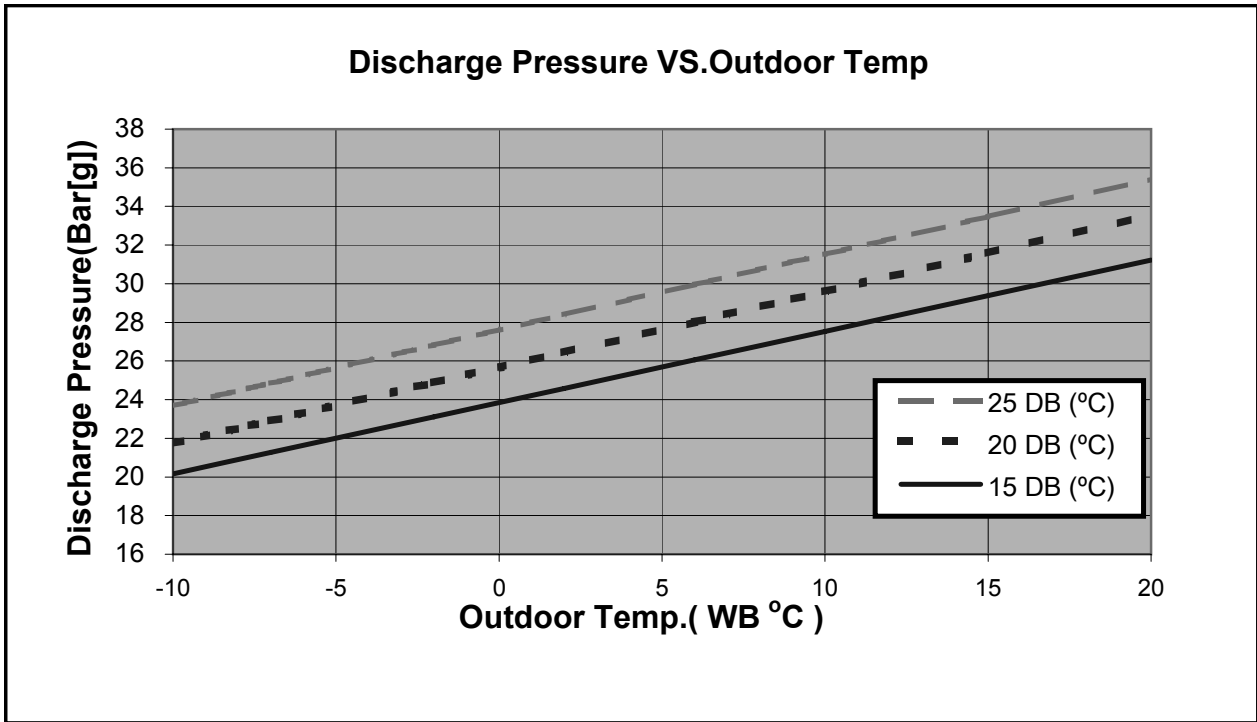

5.9 Alpha12 / GCN12

5.9.1 Cooling Mode at 7.5m Tubing Connection.

230V : Indoor Fan at High Speed.

ENTERING AIR DB OD Coil(°C)	Data	ENTERING AIR WB/DB ID Coil(°C)				
		15/21	17/24	19/27	21/29	23/32
15 ⁽¹⁾	TC	3.69	3.82	3.91	4.00	4.06
	SC	2.42	2.52	2.62	2.69	2.74
	PI	0.82	0.82	0.83	0.83	0.83
20 ⁽¹⁾	TC	3.57	3.76	3.88	3.97	4.06
	SC	2.37	2.50	2.60	2.68	2.73
	PI	0.89	0.90	0.90	0.90	0.91
25	TC	3.38	3.65	3.83	3.95	4.05
	SC	2.31	2.45	2.59	2.66	2.71
	PI	0.96	0.97	0.98	0.98	0.99
30	TC	3.16	3.44	3.71	3.85	3.96
	SC	2.24	2.38	2.53	2.60	2.65
	PI	1.04	1.06	1.07	1.07	1.08
35	TC	2.92	3.17	3.50	3.68	3.85
	SC	2.13	2.28	2.47	2.54	2.59
	PI	1.12	1.14	1.16	1.17	1.18
40	TC	2.66	2.89	3.16	3.45	3.63
	SC	2.01	2.16	2.34	2.41	2.46
	PI	1.21	1.23	1.25	1.27	1.28
46	TC	2.31	2.52	2.77	3.06	3.30
	SC	1.85	1.98	2.13	2.20	2.25
	PI	1.32	1.34	1.37	1.39	1.41

LEGEND

- TC – Total Cooling Capacity, kW
- SC – Sensible Capacity, kW
- PI – Power Input, kW
- WB – Wet Bulb Temp., (°C)
- DB – Dry Bulb Temp., (°C)
- ID – Indoor
- OD – Outdoor

(1) Marked area is below standard operating limits. For operating in low ambient conditions, an A.S.K Kit is required

5.9.2 Heating

ENTERING WB OD COIL(°C)	ENTERING AIR DB ID COIL(°C)					
	15		20		25	
	TH	PI	TH	PI	TH	PI
-10	1.98	0.94	1.91	1.00	1.83	1.05
-7	2.14	0.96	2.06	1.01	1.98	1.07
-2	2.27	0.97	2.19	1.03	2.12	1.09
2	2.76	1.02	2.65	1.08	2.53	1.15
6	3.89	1.09	3.78	1.17	3.65	1.24
10	4.23	1.15	4.12	1.23	4.01	1.32
15	4.57	1.21	4.46	1.30	4.35	1.38
20	4.82	1.24	4.71	1.35	4.57	1.45

LEGEND

- TH – Total Heating Capacity, kW
- PI – Power Input, kW
- WB – Wet Bulb Temp., (°C)
- DB – Dry Bulb Temp., (°C)
- ID – Indoor
- OD – Outdoor

5.10 Model: Alpha12 / GCN12

5.10.1 Cooling

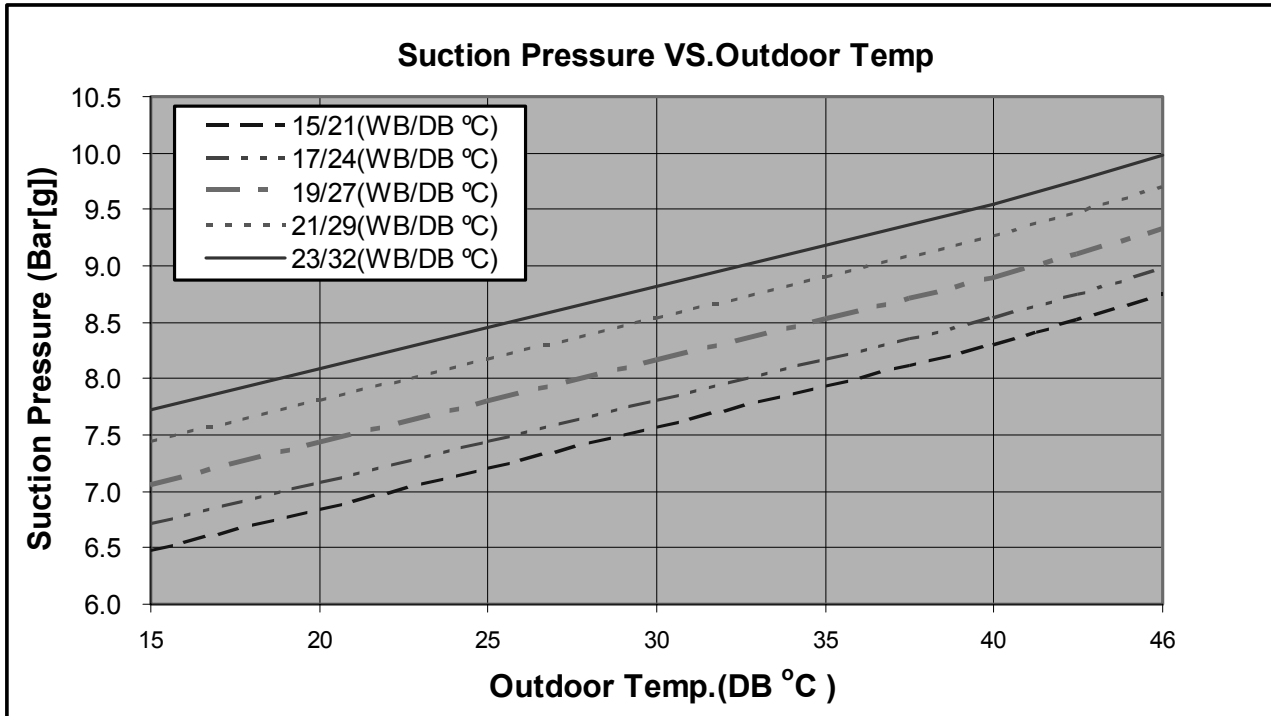
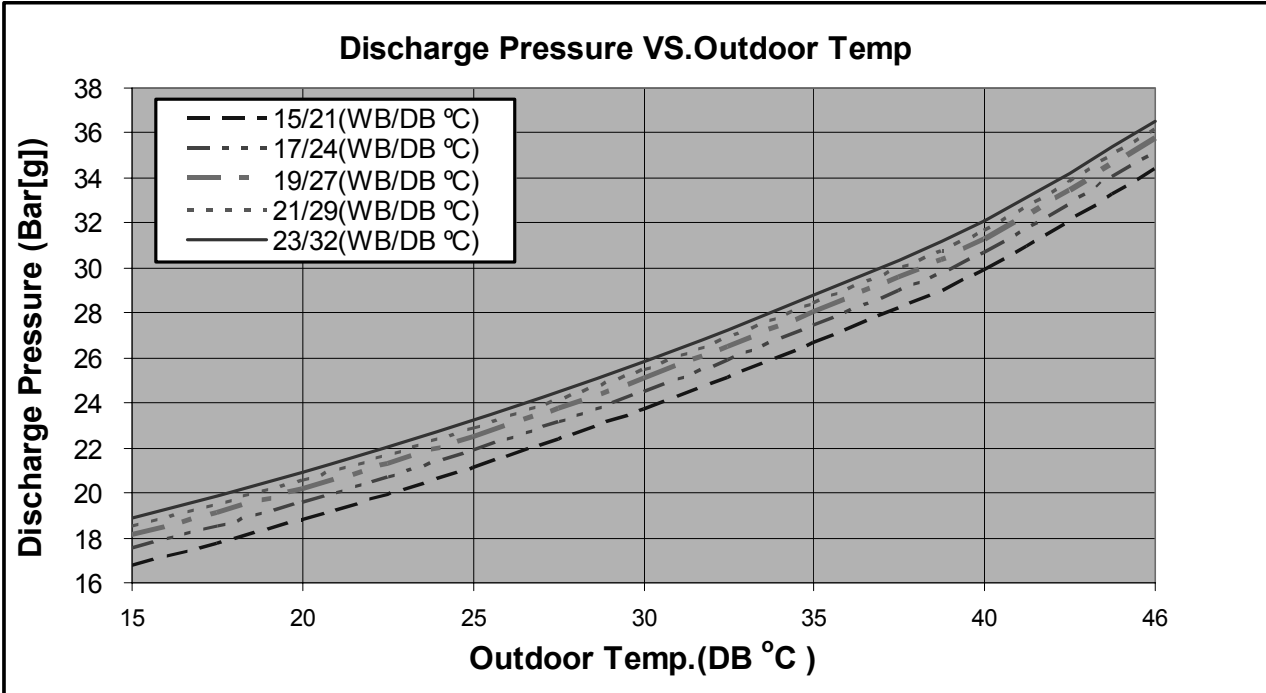

5.10.2 Heating

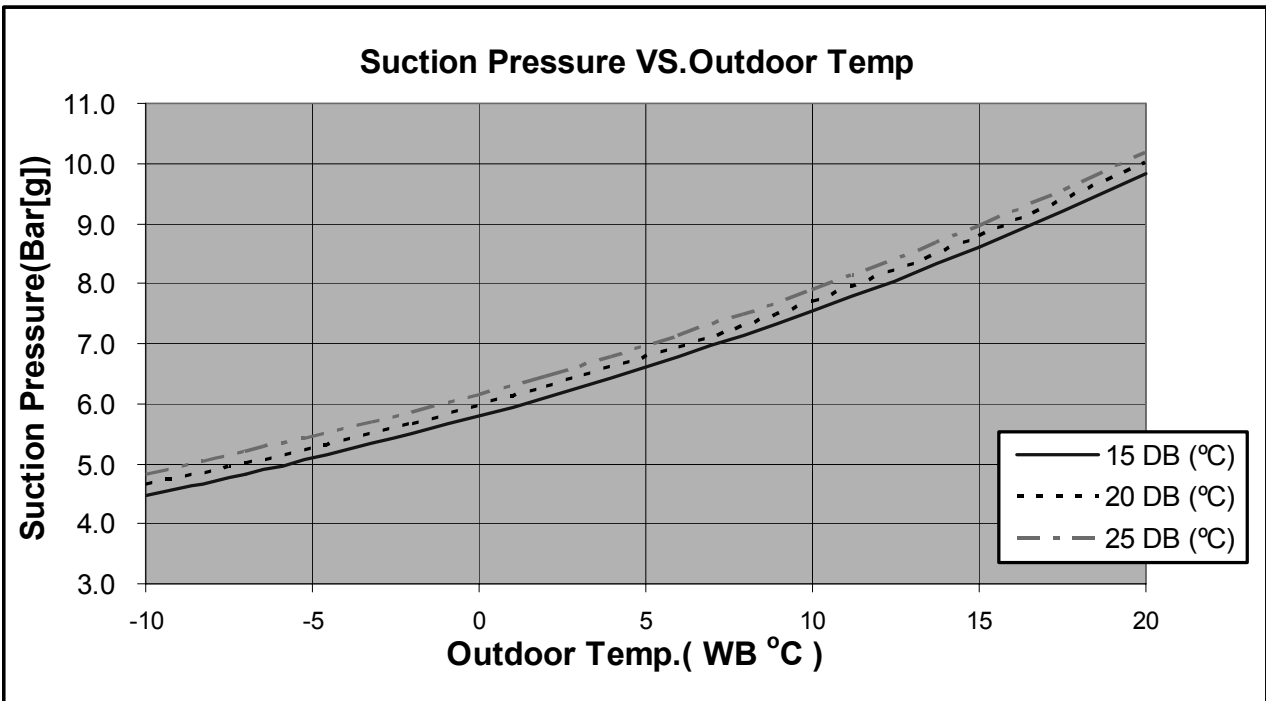
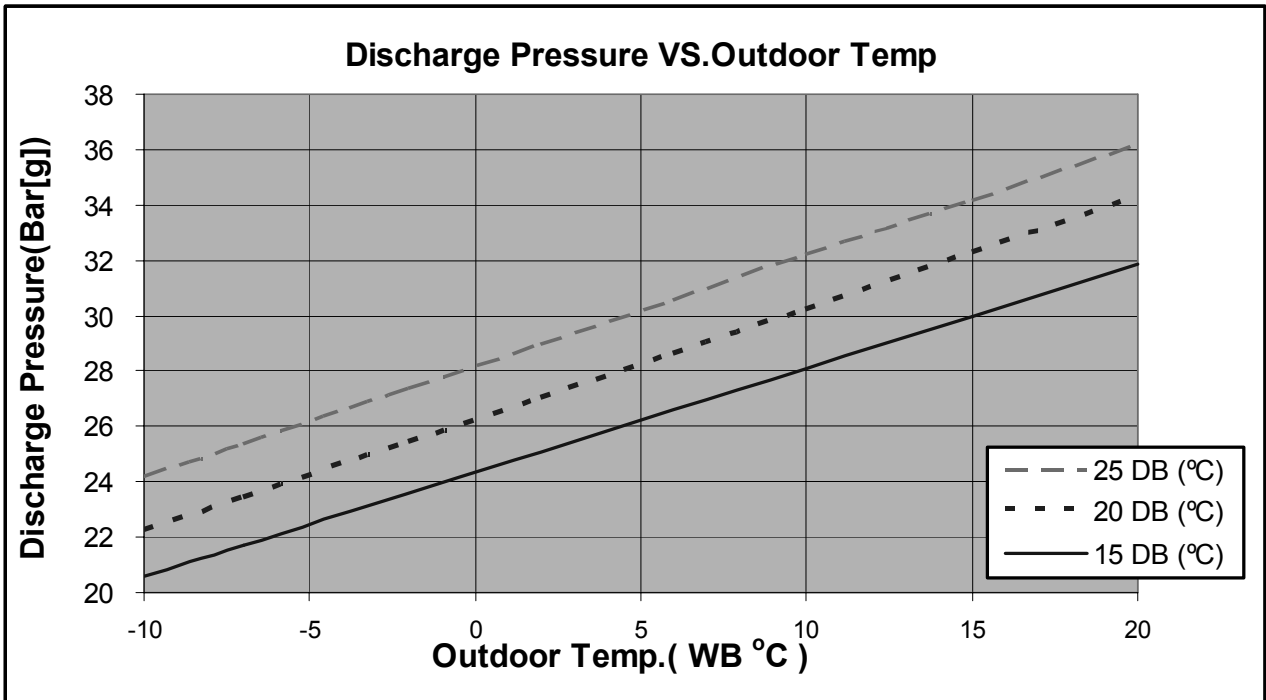

5.11 Alpha12 DF / ONG3-12 RC R410A B2

5.11.1 Cooling Mode at 7.5m Tubing Connection.

230V : Indoor Fan at High Speed.

Entering Air DB OD Coil(°C)	Data	Entering Air WB/DB ID Coil(°C)				
		15/21	17/24	19/27	21/29	23/32
15	TC	3.74	3.88	3.97	4.06	4.12
	SC	2.46	2.56	2.66	2.73	2.78
	PI	0.70	0.70	0.70	0.71	0.71
20	TC	3.62	3.82	3.94	4.03	4.12
	SC	2.41	2.54	2.65	2.72	2.77
	PI	0.76	0.76	0.77	0.77	0.77
25	TC	3.43	3.70	3.89	4.01	4.10
	SC	2.35	2.49	2.63	2.70	2.75
	PI	0.82	0.83	0.83	0.84	0.85
30	TC	3.20	3.49	3.77	3.90	4.02
	SC	2.27	2.42	2.57	2.65	2.70
	PI	0.89	0.90	0.91	0.92	0.92
35	TC	2.97	3.22	3.55	3.73	3.90
	SC	2.16	2.32	2.51	2.58	2.63
	PI	0.96	0.97	0.99	1.00	1.00
40	TC	2.70	2.94	3.20	3.50	3.68
	SC	2.04	2.19	2.38	2.45	2.50
	PI	1.03	1.05	1.07	1.08	1.09
46	TC	2.34	2.56	2.81	3.11	3.35
	SC	1.88	2.01	2.17	2.24	2.29
	PI	1.13	1.15	1.17	1.19	1.20

LEGEND

- TC – Total Cooling Capacity, kW
- SC – Sensible Capacity, kW
- PI – Power Input, kW
- WB – Wet Bulb Temp., (°C)
- DB – Dry Bulb Temp., (°C)
- ID – Indoor
- OD – Outdoor

(1) Marked area is below standard operating limits. For operating in low ambient conditions, an A.S.K Kit is required

5.11.2 Heating

ENTERING WB OD COIL(°C)	ENTERING AIR DB ID COIL(°C)					
	15		20		25	
	TH	PI	TH	PI	TH	PI
-10	1.94	0.82	1.87	0.88	1.79	0.92
-7	2.09	0.84	2.02	0.89	1.94	0.94
-2	2.22	0.85	2.15	0.91	2.07	0.96
2	2.70	0.90	2.59	0.95	2.48	1.01
6	3.81	0.96	3.70	1.03	3.57	1.09
10	4.14	1.02	4.03	1.09	3.92	1.16
15	4.48	1.06	4.37	1.14	4.26	1.22
20	4.72	1.09	4.61	1.18	4.48	1.28

LEGEND

- TH – Total Heating Capacity, kW
- PI – Power Input, kW
- WB – Wet Bulb Temp., (°C)
- DB – Dry Bulb Temp., (°C)
- ID – Indoor
- OD – Outdoor

5.12 Model: Alpha12 DF / ONG3-12 RC R410A B2

5.12.1 Cooling

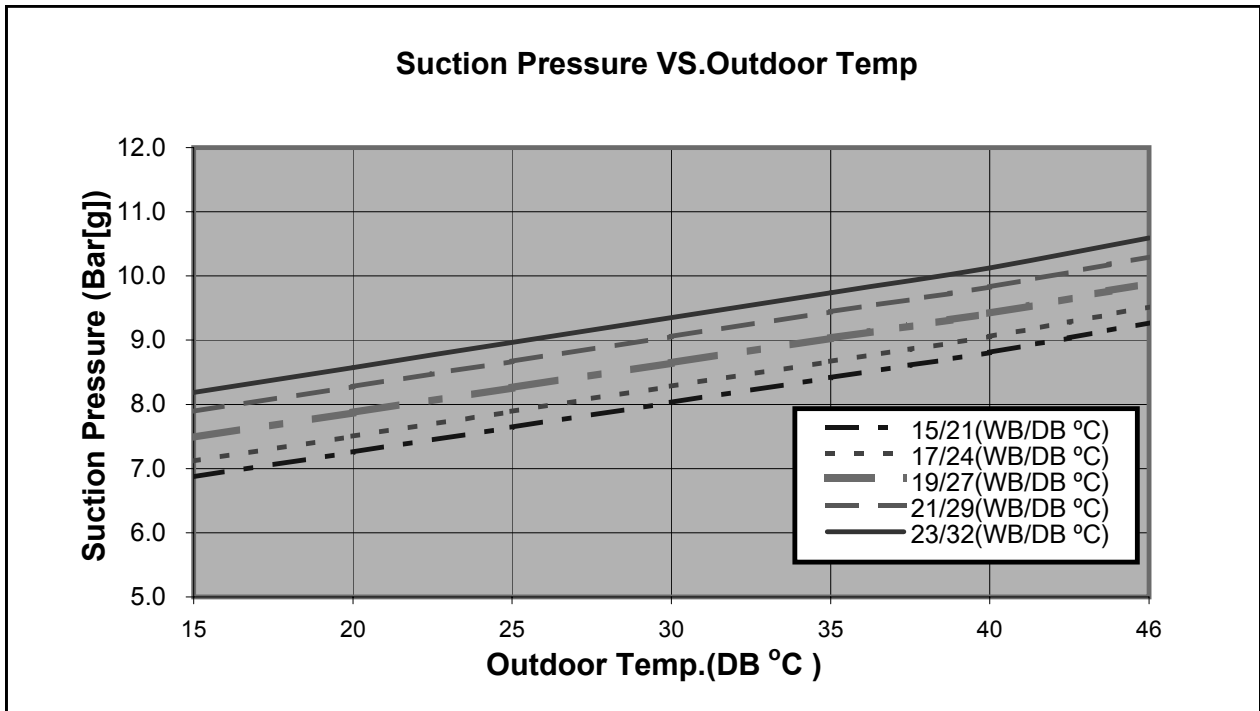
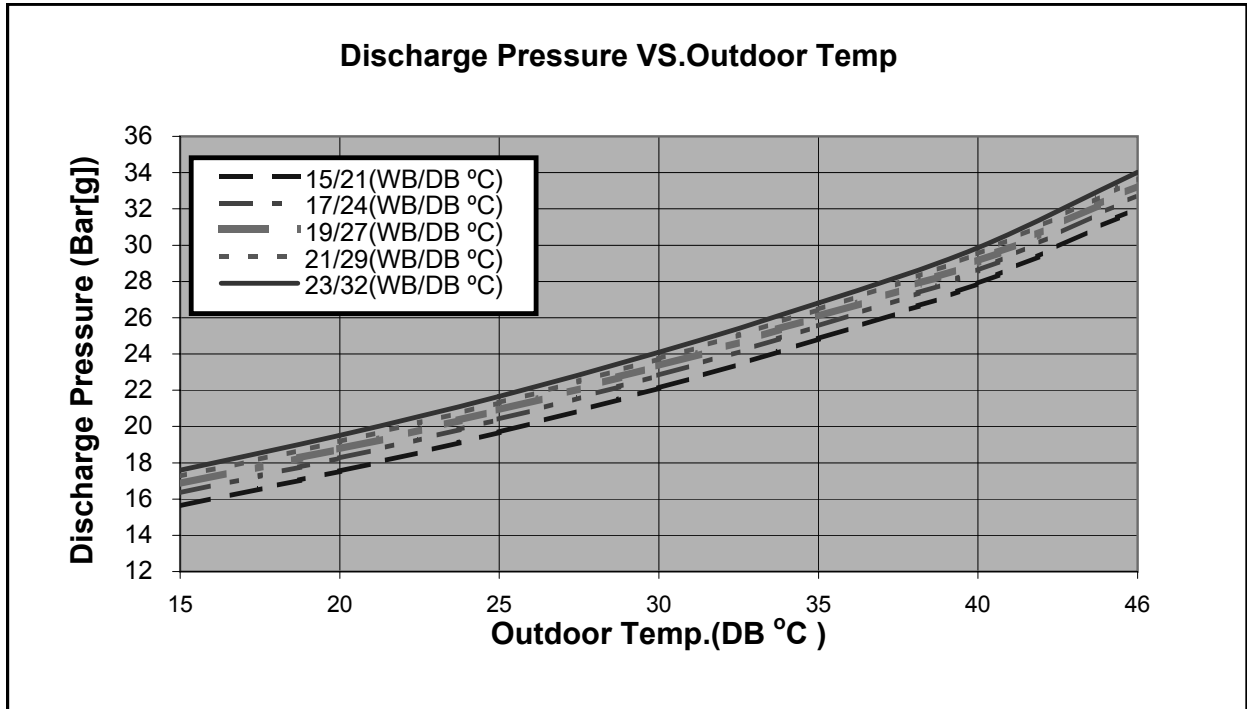

5.12.2 Heating

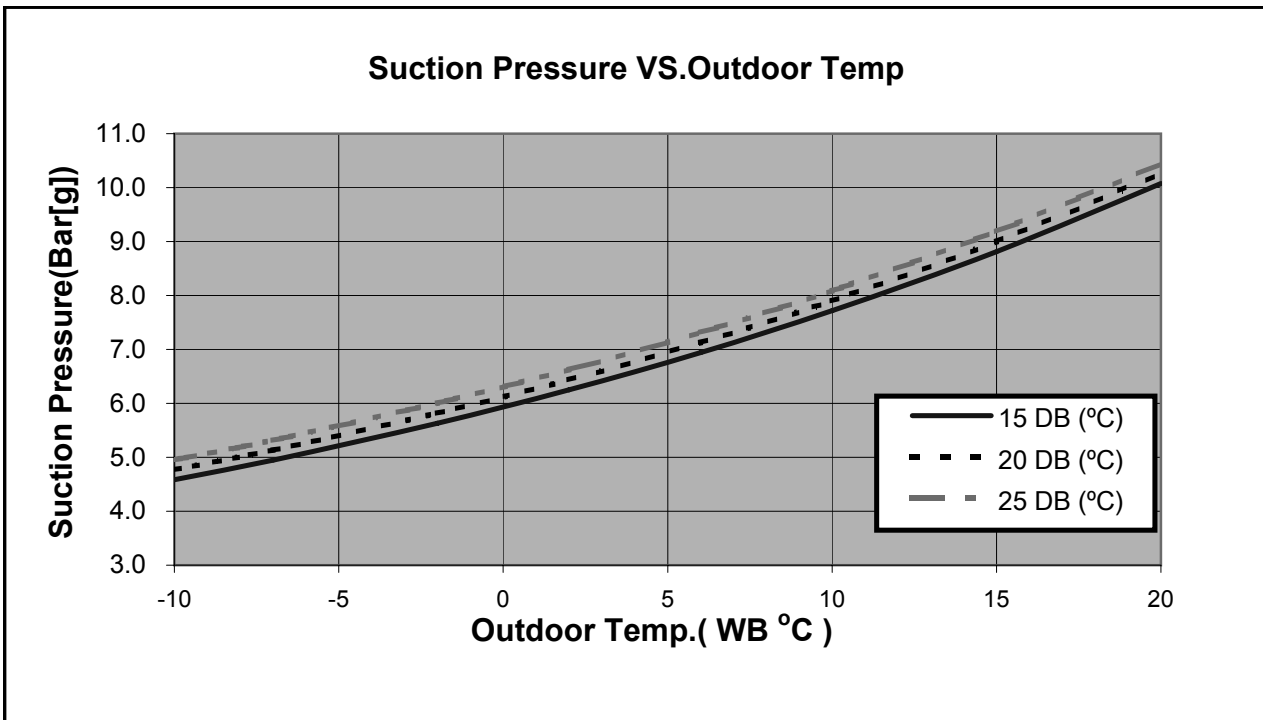
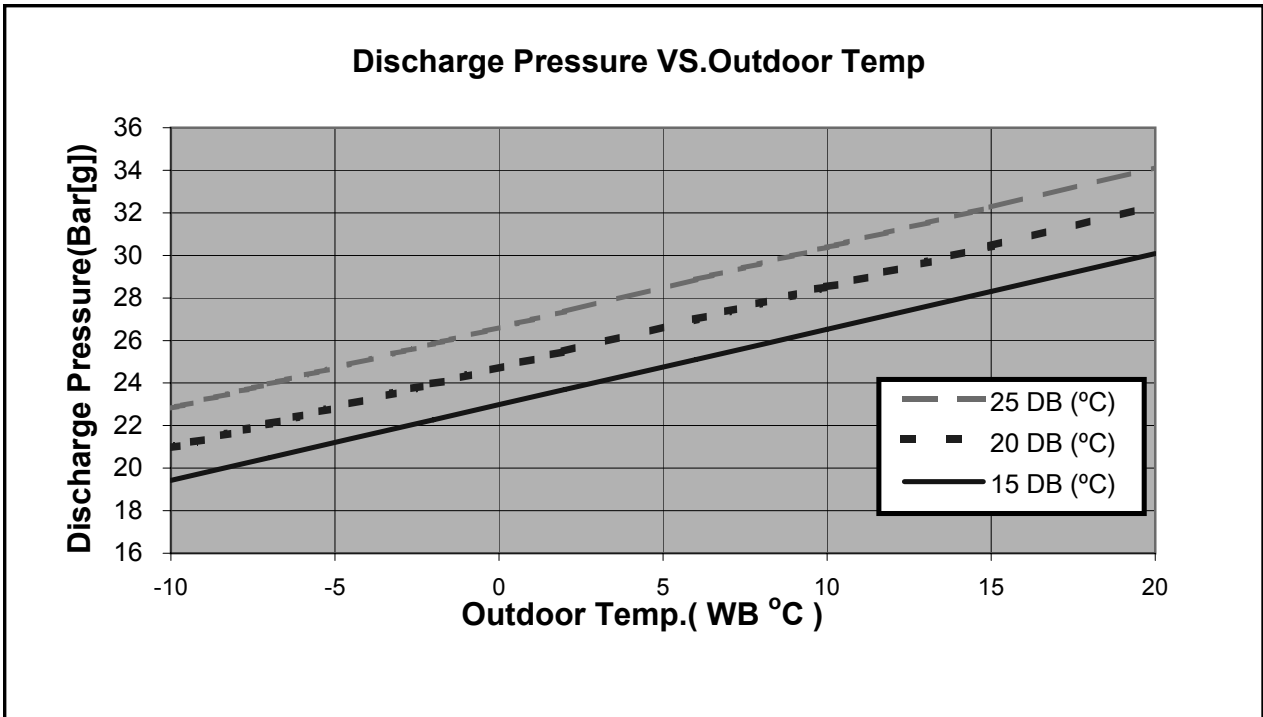

5.13 Alpha17 DF / ONG3-14 RC R410A B2

5.13.1 Cooling Mode at 7.5m Tubing Connection.

230V : Indoor Fan at High Speed.

Entering Air DB OD Coil(°C)	Data	Entering Air WB/DB ID Coil(°C)				
		15/21	17/24	19/27	21/29	23/32
15	TC	4.95	5.13	5.25	5.38	5.46
	SC	3.06	3.19	3.32	3.40	3.46
	PI	0.99	0.99	1.00	1.00	1.00
20	TC	4.79	5.05	5.21	5.33	5.45
	SC	3.00	3.16	3.30	3.39	3.45
	PI	1.08	1.08	1.08	1.09	1.09
25	TC	4.53	4.90	5.15	5.30	5.43
	SC	2.92	3.10	3.27	3.37	3.43
	PI	1.16	1.17	1.18	1.19	1.20
30	TC	4.24	4.62	4.99	5.17	5.32
	SC	2.83	3.01	3.20	3.29	3.36
	PI	1.26	1.27	1.29	1.30	1.31
35	TC	3.93	4.26	4.70	4.94	5.17
	SC	2.69	2.89	3.13	3.22	3.28
	PI	1.35	1.38	1.40	1.41	1.42
40	TC	3.57	3.89	4.24	4.64	4.88
	SC	2.54	2.73	2.96	3.05	3.11
	PI	1.46	1.48	1.51	1.53	1.54
46	TC	3.10	3.39	3.72	4.12	4.43
	SC	2.34	2.50	2.70	2.79	2.85
	PI	1.60	1.62	1.66	1.68	1.70

LEGEND

- TC – Total Cooling Capacity, kW
- SC – Sensible Capacity, kW
- PI – Power Input, kW
- WB – Wet Bulb Temp., (°C)
- DB – Dry Bulb Temp., (°C)
- ID – Indoor
- OD – Outdoor

(1) Marked area is below standard operating limits. For operating in low ambient conditions, an A.S.K Kit is required

5.13.2 Heating

ENTERING WB OD COIL(°C)	ENTERING AIR DB ID COIL(°C)					
	15		20		25	
	TH	PI	TH	PI	TH	PI
-10	2.57	1.12	2.47	1.19	2.38	1.25
-7	2.77	1.15	2.67	1.21	2.57	1.28
-2	2.94	1.16	2.84	1.23	2.74	1.30
2	3.58	1.22	3.43	1.30	3.28	1.37
6	5.05	1.31	4.90	1.40	4.73	1.49
10	5.49	1.38	5.34	1.48	5.19	1.58
15	5.93	1.44	5.78	1.55	5.64	1.65
20	6.25	1.48	6.10	1.61	5.93	1.74

LEGEND

- TH – Total Heating Capacity, kW
- PI – Power Input, kW
- WB – Wet Bulb Temp., (°C)
- DB – Dry Bulb Temp., (°C)
- ID – Indoor
- OD – Outdoor

5.14 Model: Alpha17 DF / ONG3-14 RC R410A B2

5.14.1 Cooling

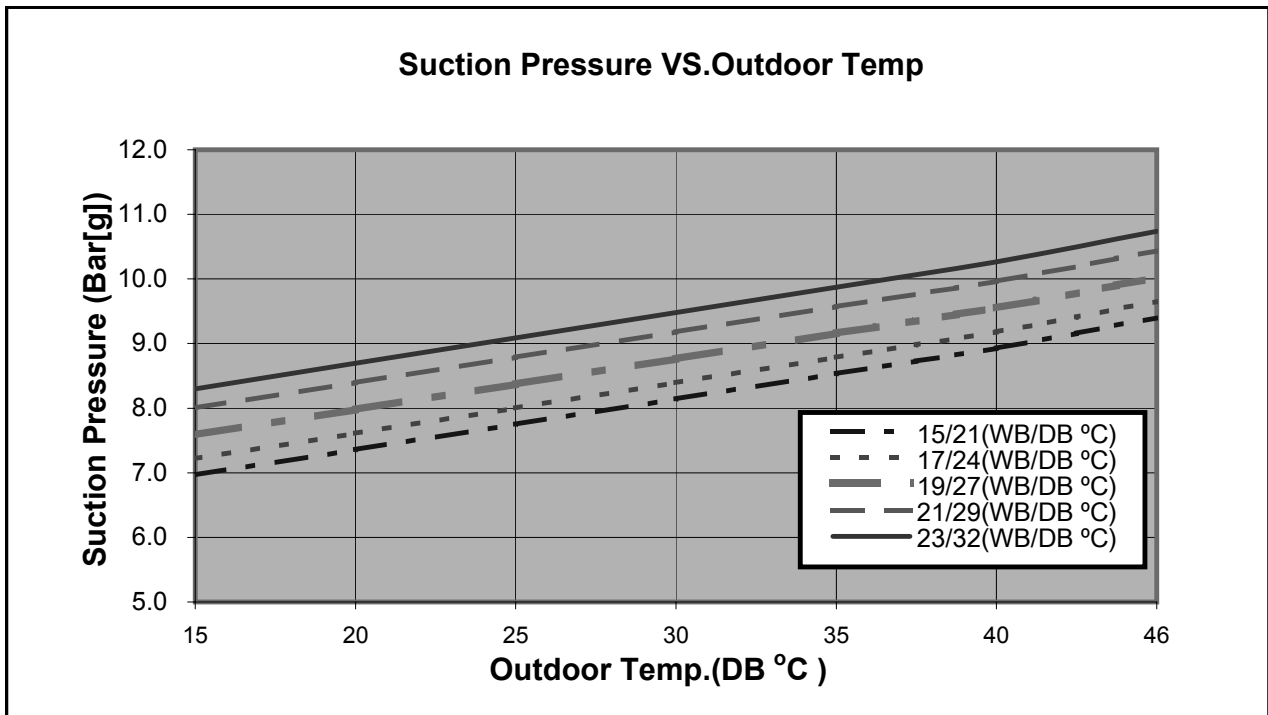
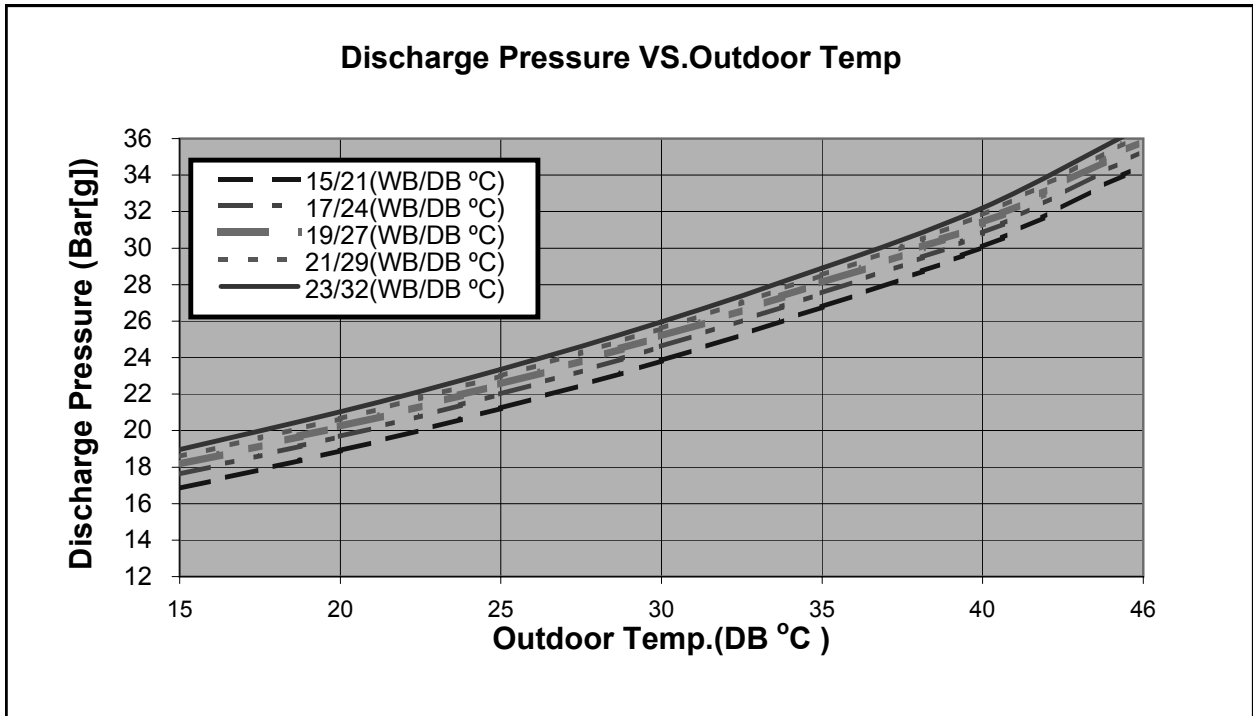

5.14.2 Heating

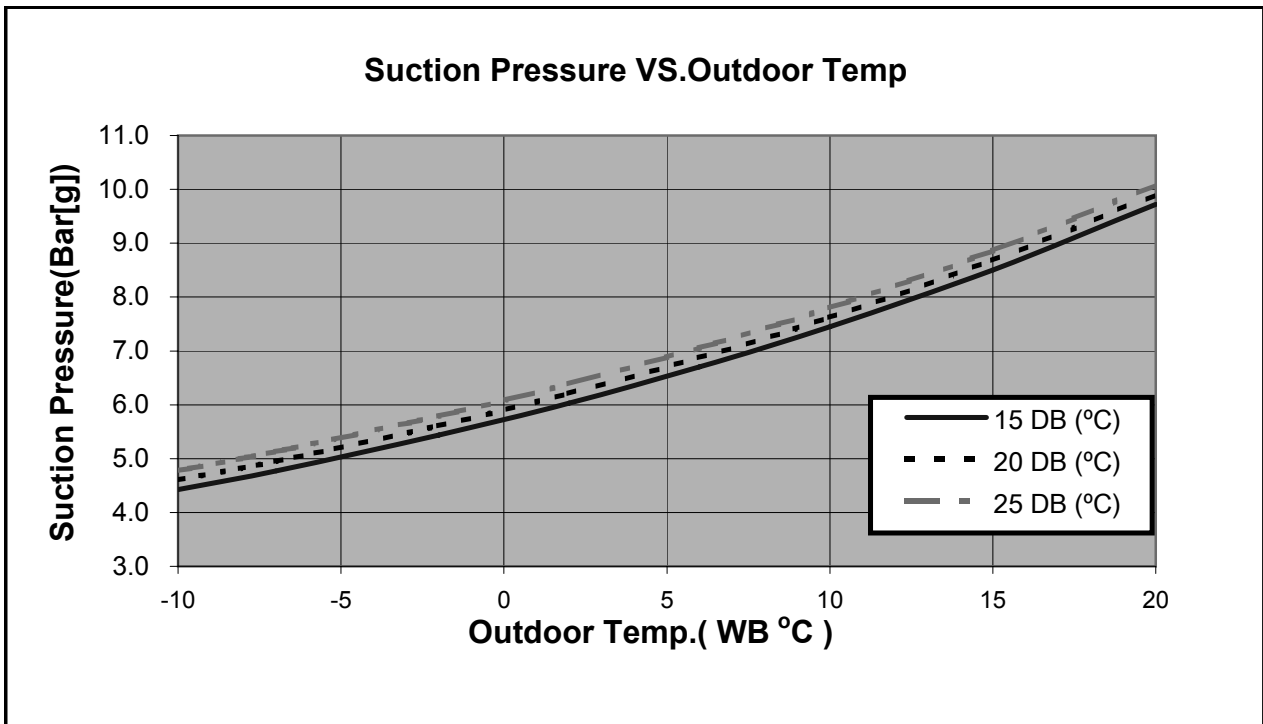
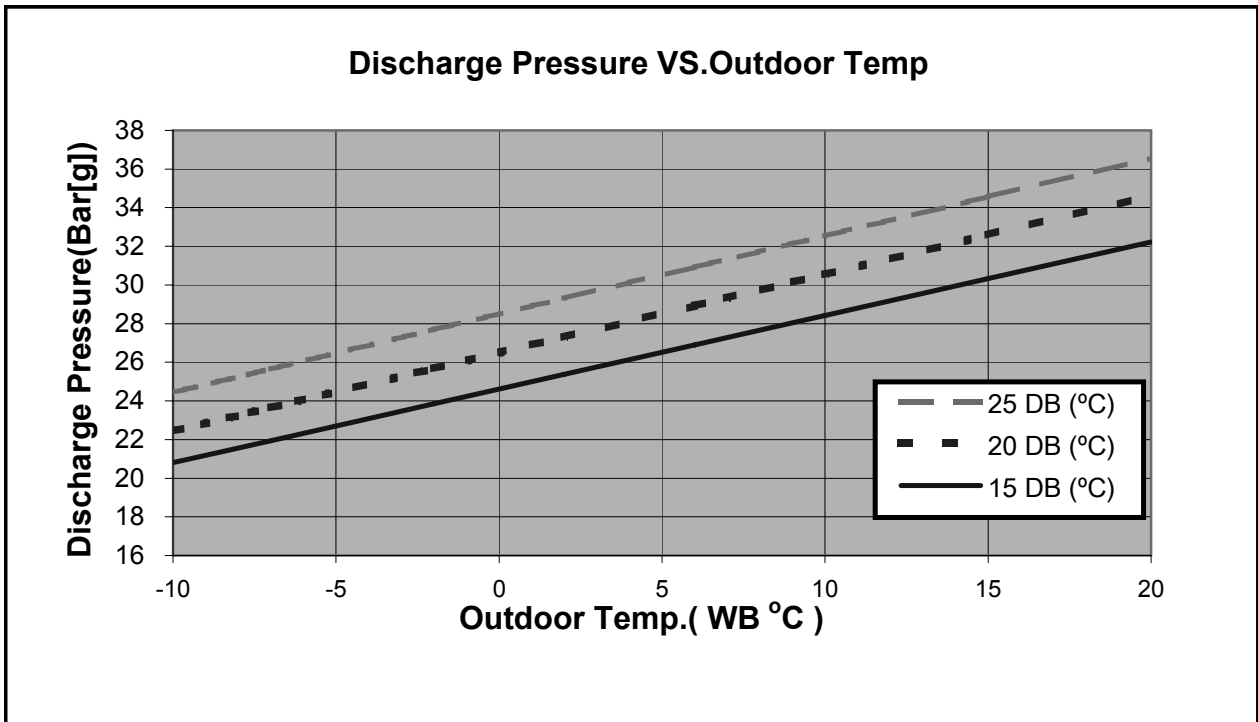

5.15 Model: Alpha17/ ONG17 R410A

5.15.1 Cooling Mode at 7.5m Tubing Connection.

230V : Indoor Fan at High Speed.

ENTERING AIR DB OD COIL (°C)	DATA	ENTERING AIR WB/DB ID COIL (°C)				
		15/21	17/24	19/27	21/29	23/32
15 ⁽¹⁾	TC	5.43	5.62	5.75	5.89	5.98
	SC	3.56	3.72	3.86	3.96	4.03
	PI	1.21	1.21	1.21	1.21	1.22
20 ⁽¹⁾	TC	5.25	5.54	5.71	5.85	5.97
	SC	3.49	3.68	3.84	3.95	4.02
	PI	1.31	1.31	1.32	1.32	1.33
25	TC	4.97	5.36	5.64	5.81	5.95
	SC	3.40	3.61	3.81	3.92	3.99
	PI	1.41	1.42	1.43	1.44	1.45
30	TC	4.65	5.06	5.47	5.66	5.83
	SC	3.30	3.50	3.73	3.84	3.91
	PI	1.53	1.55	1.56	1.57	1.59
35	TC	4.30	4.67	5.15	5.41	5.66
	SC	3.14	3.36	3.64	3.75	3.82
	PI	1.65	1.67	1.70	1.71	1.72
40	TC	3.91	4.26	4.65	5.08	5.34
	SC	2.95	3.18	3.44	3.55	3.63
	PI	1.77	1.80	1.83	1.86	1.87
46	TC	3.39	3.71	4.08	4.51	4.86
	SC	2.72	2.92	3.14	3.25	3.32
	PI	1.94	1.97	2.01	2.04	2.06

LEGEND

- TC – Total Cooling Capacity, kWv
- SC – Sensible Capacity, kW
- PI – Power Input, kW
- WB – Wet Bulb Temp., (°C)
- DB – Dry Bulb Temp., (°C)
- ID – Indoor
- OD – Outdoor

(1) Marked area is below standard operating limits. For operating in low ambient conditions, refer to Optional Accessories (Chapter 15).

5.15.2 Heating Mode at 7.5m Tubing Connection.

230V : Indoor Fan at High Speed.

ENTERING AIR WB OU COIL (°C)	ENTERING AIR DB ID COIL (°C)					
	15		20		25	
	TH	PI	TH	PI	TH	PI
-10	2.81	1.32	2.70	1.41	2.59	1.48
-7	3.02	1.35	2.92	1.43	2.81	1.50
-2	3.21	1.37	3.10	1.45	3.00	1.53
2	3.91	1.44	3.75	1.53	3.58	1.62
6	5.51	1.54	5.35	1.65	5.16	1.75
10	5.99	1.63	5.83	1.74	5.67	1.86
15	6.47	1.70	6.31	1.83	6.15	1.95
20	6.82	1.75	6.66	1.90	6.47	2.05

* the above chart includes the weighted deicing influence.

LEGEND

- TH – Total Heating Capacity, kW
- PI – Power Input, kW
- WB – Wet Bulb Temp., (°C)
- DB – Dry Bulb Temp., (°C)
- ID – Indoor
- OU – Outdoor

5.16 Capacity Correction Factor Due to Tubing Length

5.16.1 Cooling

Model	TOTAL TUBING LENGTH (One Way)								
	3m	7.5m	10m	15m	20m	25m	30m	40m	50m
Alpha7,9,12,17	1.02	1	0.97	0.95	---	---	---	---	---

* Minimum recommended tubing length between indoor and outdoor units is 3m.

5.16.2 Heating

Model	TOTAL TUBING LENGTH(One Way)								
	3m	7.5m	10m	15m	20m	25m	30m	40m	50m
Alpha7,9,12,17	1.03	1	0.98	0.96	---	---	---	---	---

* Minimum recommended tubing length between indoor and outdoor units is 3m.

5.17 Model: Alpha17/ONG3-17

5.17.1 Cooling

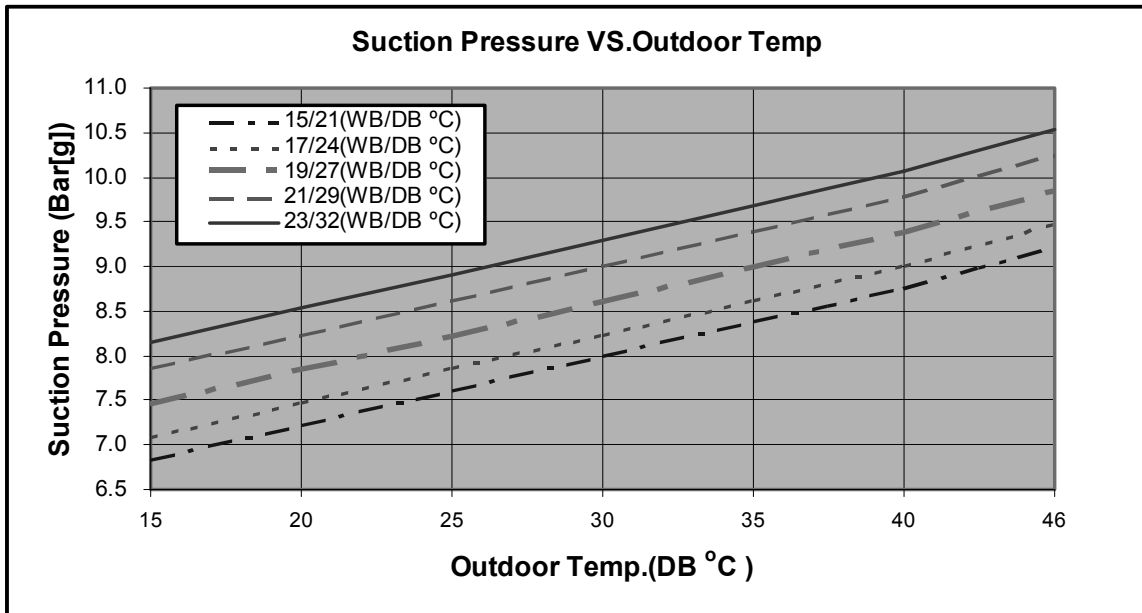
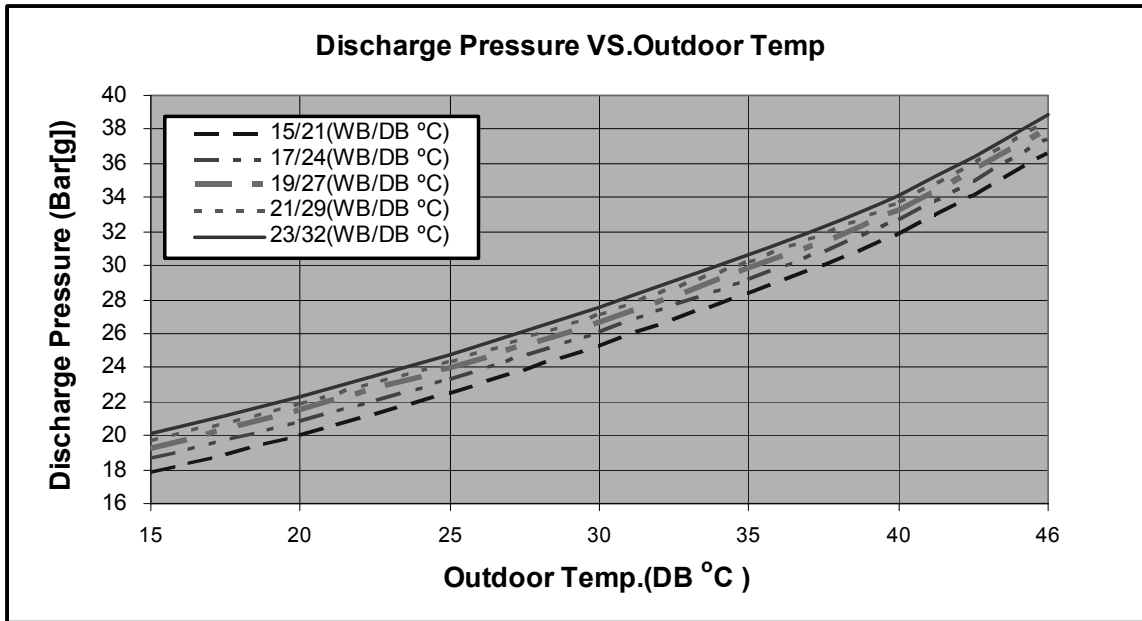

5.17.2 Heating.

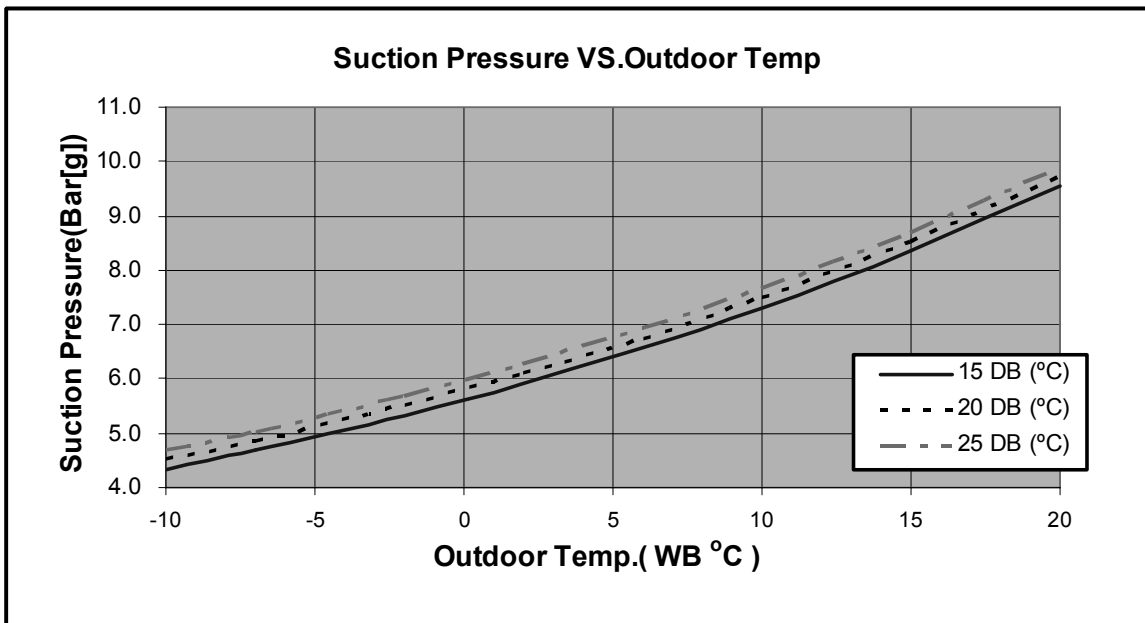
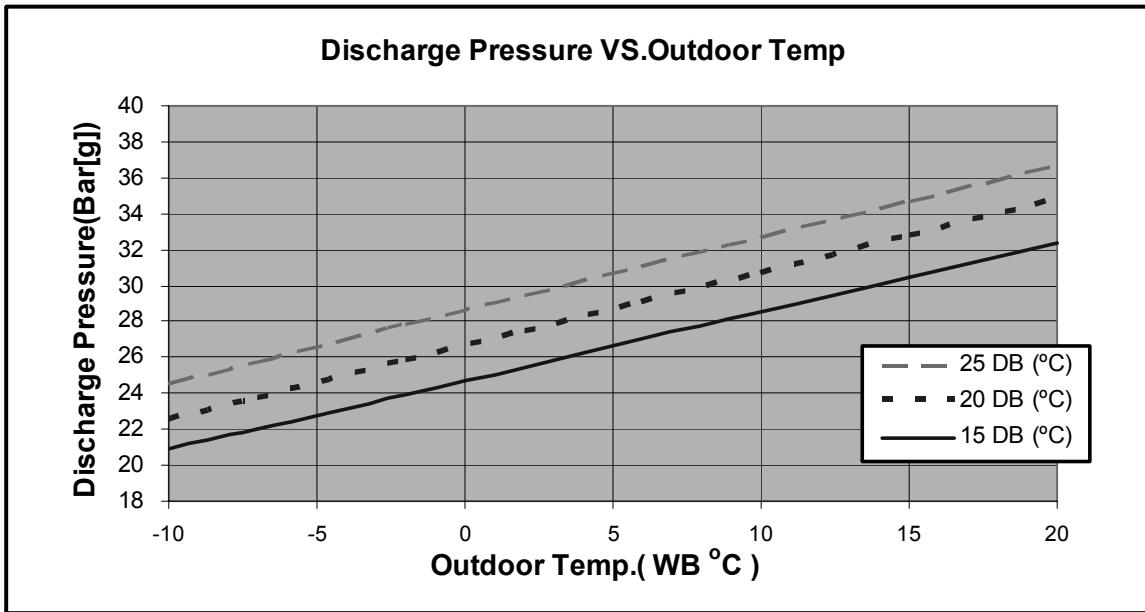

5.18 Model: ALPHA17 DF / ONG3-17RC R410A B2

5.18.1 Cooling Mode at 7.5m Tubing Connection.

230V : Indoor Fan at High Speed.

Entering Air DB OD Coil(°C)	Data	Entering Air WB/DB ID Coil(°C)				
		15/21	17/24	19/27	21/29	23/32
15	TC	5.69	5.89	6.03	6.18	6.27
	SC	3.38	3.53	3.66	3.76	3.83
	PI	1.20	1.20	1.20	1.21	1.21
20	TC	5.51	5.80	5.99	6.13	6.26
	SC	3.32	3.49	3.64	3.75	3.82
	PI	1.30	1.31	1.31	1.32	1.32
25	TC	5.21	5.63	5.91	6.09	6.24
	SC	3.23	3.43	3.62	3.72	3.79
	PI	1.41	1.42	1.43	1.43	1.44
30	TC	4.87	5.31	5.73	5.94	6.11
	SC	3.13	3.33	3.54	3.64	3.71
	PI	1.52	1.54	1.55	1.56	1.58
35	TC	4.51	4.90	5.40	5.67	5.94
	SC	2.98	3.19	3.45	3.55	3.62
	PI	1.64	1.66	1.69	1.70	1.71
40	TC	4.10	4.47	4.87	5.33	5.60
	SC	2.80	3.02	3.27	3.37	3.44
	PI	1.76	1.79	1.82	1.84	1.86
46	TC	3.56	3.89	4.28	4.73	5.09
	SC	2.58	2.77	2.98	3.08	3.15
	PI	1.93	1.96	2.00	2.03	2.05

LEGEND

- TC – Total Cooling Capacity, kWv
- SC – Sensible Capacity, kW
- PI – Power Input, kW
- WB – Wet Bulb Temp., (°C)
- DB – Dry Bulb Temp., (°C)
- ID – Indoor
- OD – Outdoor

(1) Marked area is below standard operating limits. For operating in low ambient conditions, refer to Optional Accessories (Chapter 15).

5.8.2 Heating

ENTERING WB OD COIL(°C)	ENTERING AIR DB ID COIL(°C)					
	15		20		25	
	TH	PI	TH	PI	TH	PI
-10	2.89	1.34	2.78	1.42	2.67	1.49
-7	3.11	1.37	3.00	1.44	2.89	1.52
-2	3.30	1.39	3.19	1.47	3.08	1.55
2	4.02	1.45	3.85	1.54	3.69	1.64
6	5.67	1.56	5.50	1.67	5.31	1.77
10	6.16	1.65	6.00	1.76	5.83	1.88
15	6.66	1.72	6.49	1.85	6.33	1.97
20	7.01	1.77	6.85	1.92	6.66	2.07

LEGEND

- TH – Total Heating Capacity, kW
- PI – Power Input, kW
- WB – Wet Bulb Temp., (°C)
- DB – Dry Bulb Temp., (°C)
- ID – Indoor
- OD – Outdoor

5.19 Model: ALPHA17 DF / ONG3-17RC R410A B2

5.19.1 Cooling

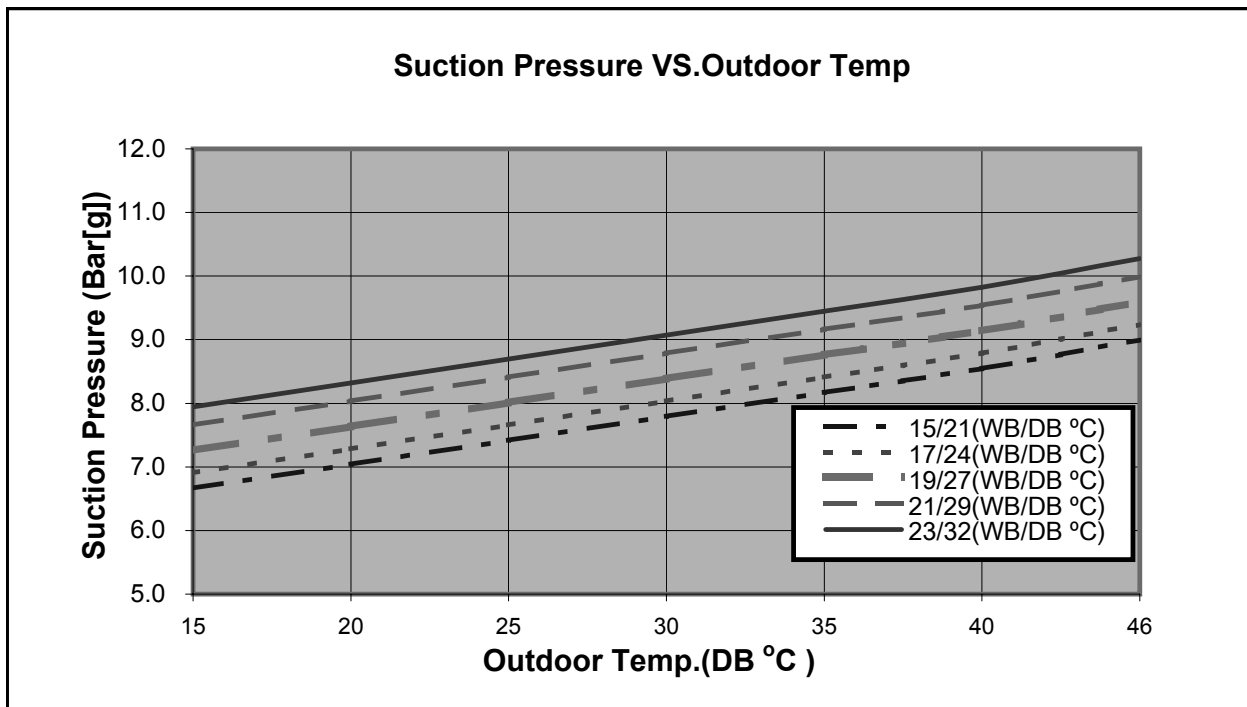
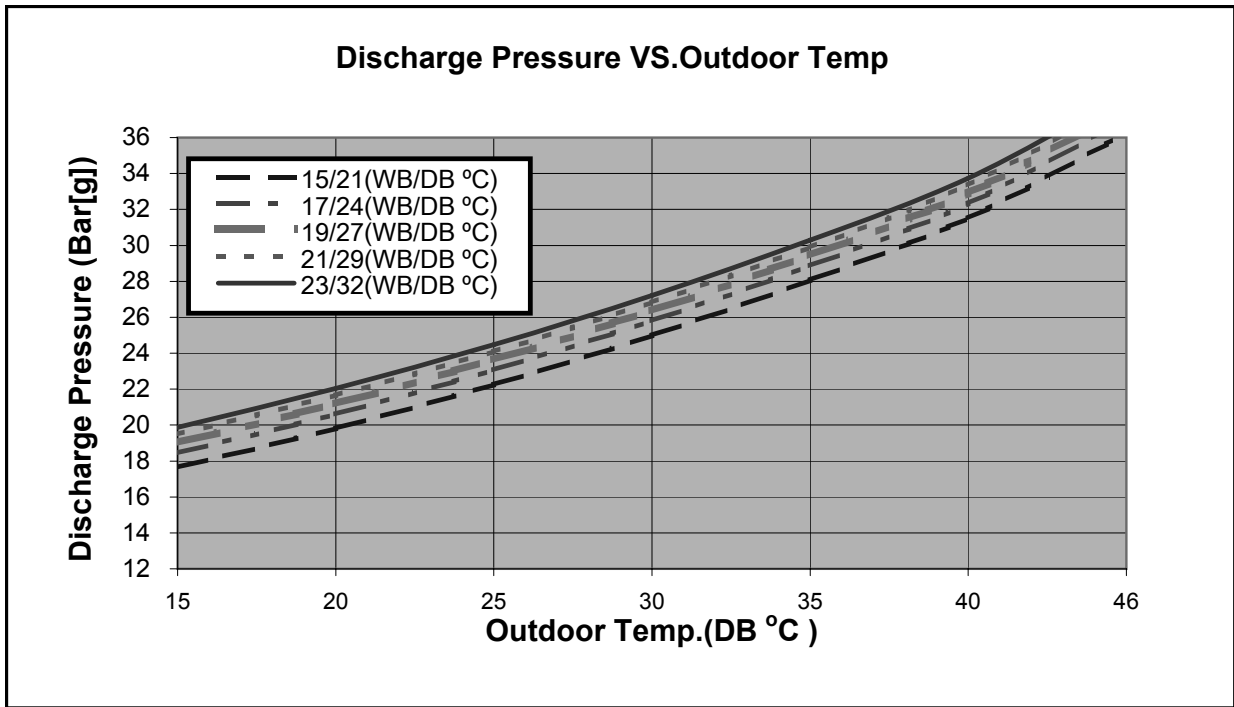

5.19.2 Heating.

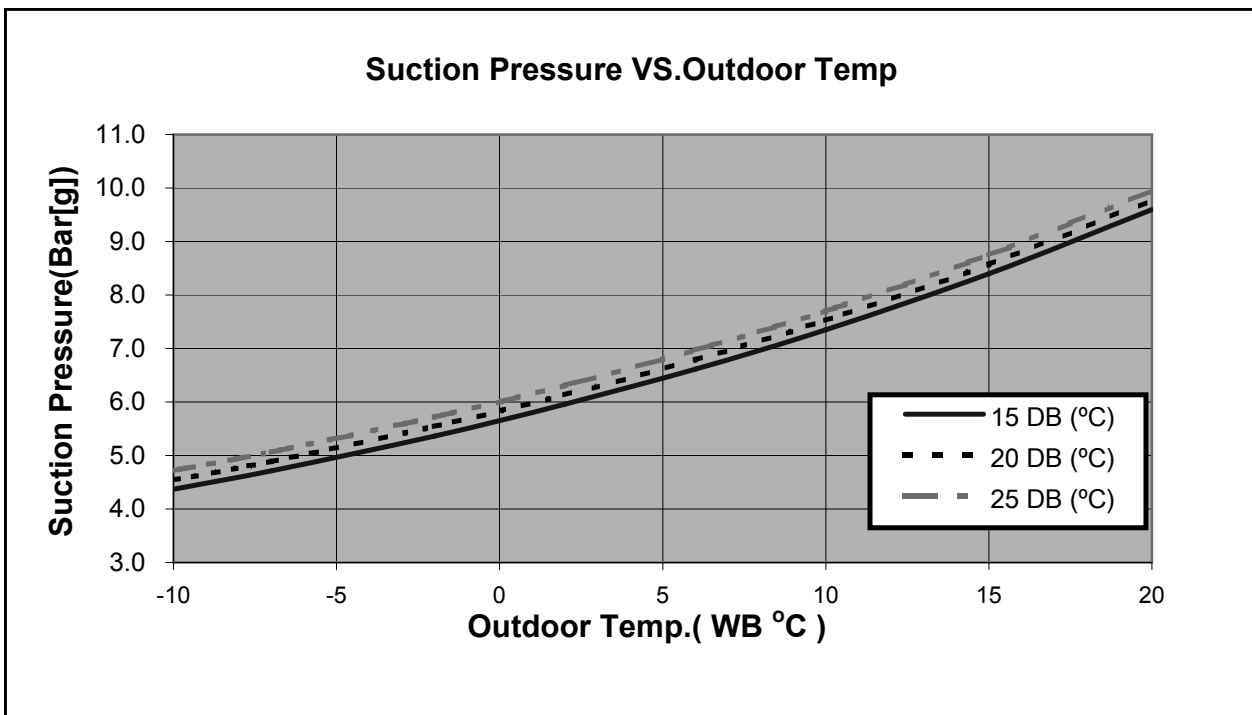
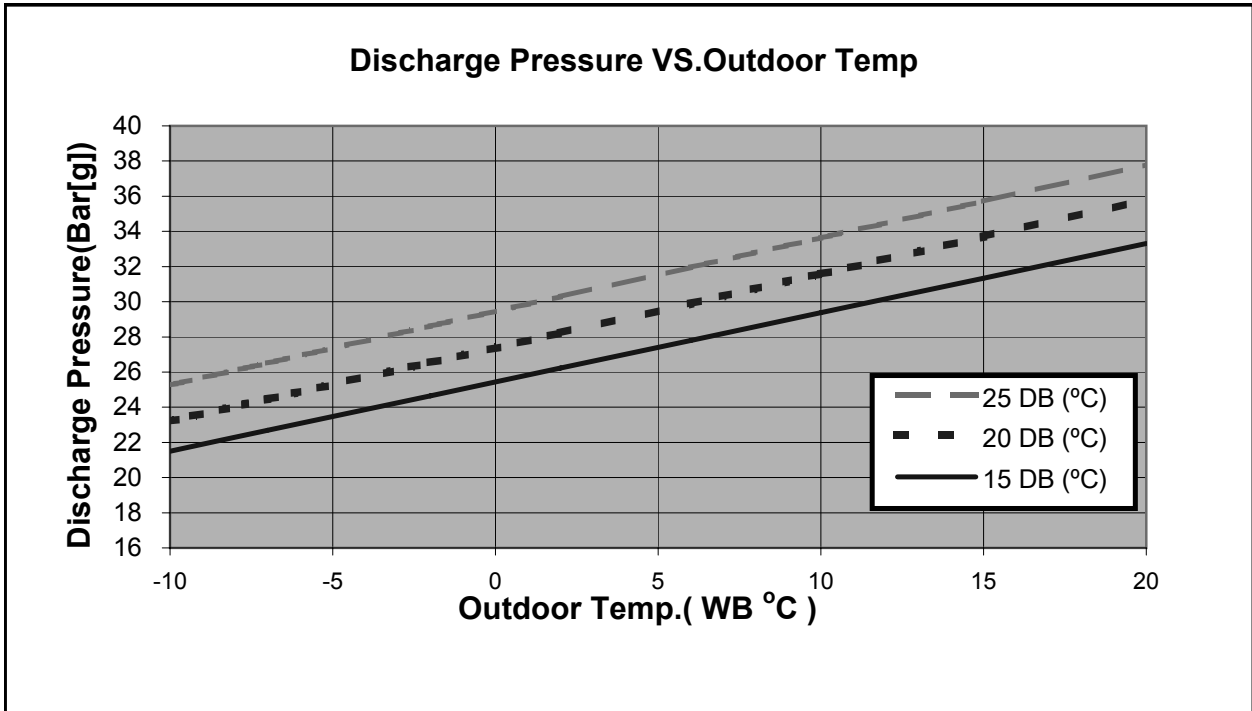

5.20 Model: Delta 24 / OU7-24C R410A

5.20.1 Cooling Mode at 7.5m Tubing Connection.

230V : Indoor Fan at High Speed.

Entering Air DB OD Coil(°C)	Data	Entering Air WB/DB ID Coil(°C)				
		15/21	17/24	19/27	21/29	23/32
15	TC	7.14	7.39	7.57	7.74	7.86
	SC	4.80	5.00	5.20	5.33	5.43
	PI	1.59	1.59	1.59	1.60	1.61
20	TC	6.90	7.28	7.51	7.68	7.85
	SC	4.70	4.96	5.17	5.31	5.41
	PI	1.72	1.73	1.74	1.75	1.75
25	TC	6.53	7.05	7.42	7.64	7.83
	SC	4.58	4.86	5.13	5.28	5.37
	PI	1.86	1.88	1.89	1.90	1.91
30	TC	6.11	6.65	7.19	7.44	7.66
	SC	4.44	4.72	5.02	5.16	5.26
	PI	2.01	2.04	2.06	2.07	2.09
35	TC	5.66	6.14	6.77	7.11	7.45
	SC	4.22	4.52	4.90	5.04	5.14
	PI	2.17	2.20	2.24	2.26	2.27
40	TC	5.14	5.60	6.11	6.68	7.02
	SC	3.98	4.28	4.64	4.78	4.88
	PI	2.34	2.37	2.41	2.45	2.47
46	TC	4.46	4.88	5.37	5.93	6.39
	SC	3.66	3.93	4.23	4.37	4.47
	PI	2.56	2.59	2.65	2.69	2.72

LEGEND

- TC – Total Cooling Capacity, kWv
- SC – Sensible Capacity, kW
- PI – Power Input, kW
- WB – Wet Bulb Temp., (°C)
- DB – Dry Bulb Temp., (°C)
- ID – Indoor
- OD – Outdoor

(1) Marked area is below standard operating limits. For operating in low ambient conditions, refer to Optional Accessories (Chapter 15).

5.20.2 Heating

ENTERING WB OD COIL(°C)	ENTERING AIR DB ID COIL(°C)					
	15		20		25	
	TH	PI	TH	PI	TH	PI
-10	3.72	1.88	3.58	2.00	3.43	2.10
-7	4.00	1.93	3.86	2.03	3.72	2.14
-2	4.25	1.95	4.11	2.07	3.96	2.19
2	5.17	2.04	4.96	2.17	4.74	2.30
6	7.29	2.20	7.08	2.35	6.83	2.50
10	7.93	2.32	7.72	2.48	7.50	2.65
15	8.57	2.42	8.35	2.61	8.14	2.77
20	9.03	2.49	8.81	2.70	8.57	2.91

LEGEND

- TH – Total Heating Capacity, kW
- PI – Power Input, kW
- WB – Wet Bulb Temp., (°C)
- DB – Dry Bulb Temp., (°C)
- ID – Indoor
- OD – Outdoor

5.21 Model: Delta 24 / OU7-24C R410A

5.21.1 Cooling

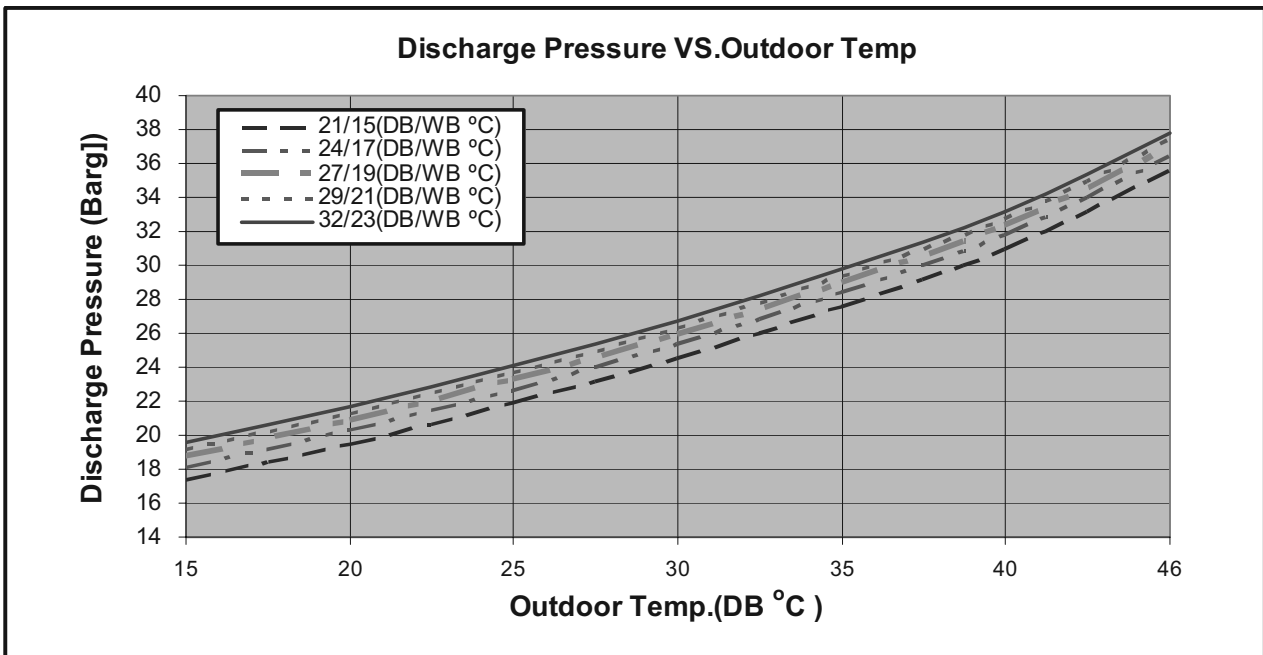
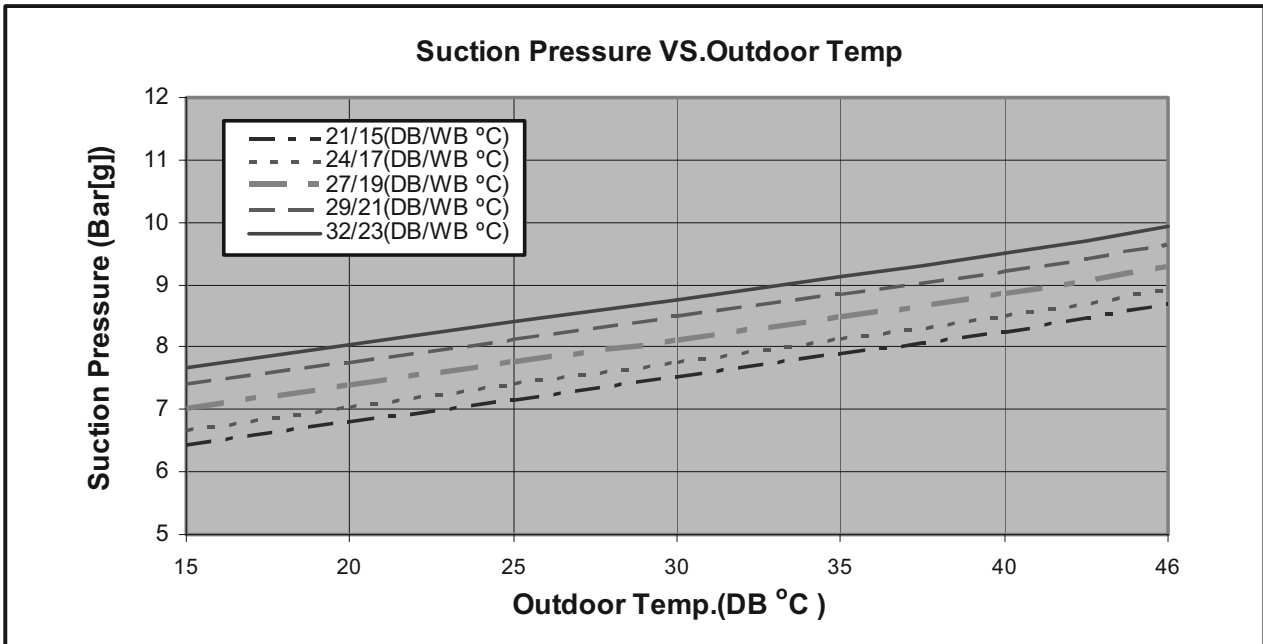

5.21.2 Heating.

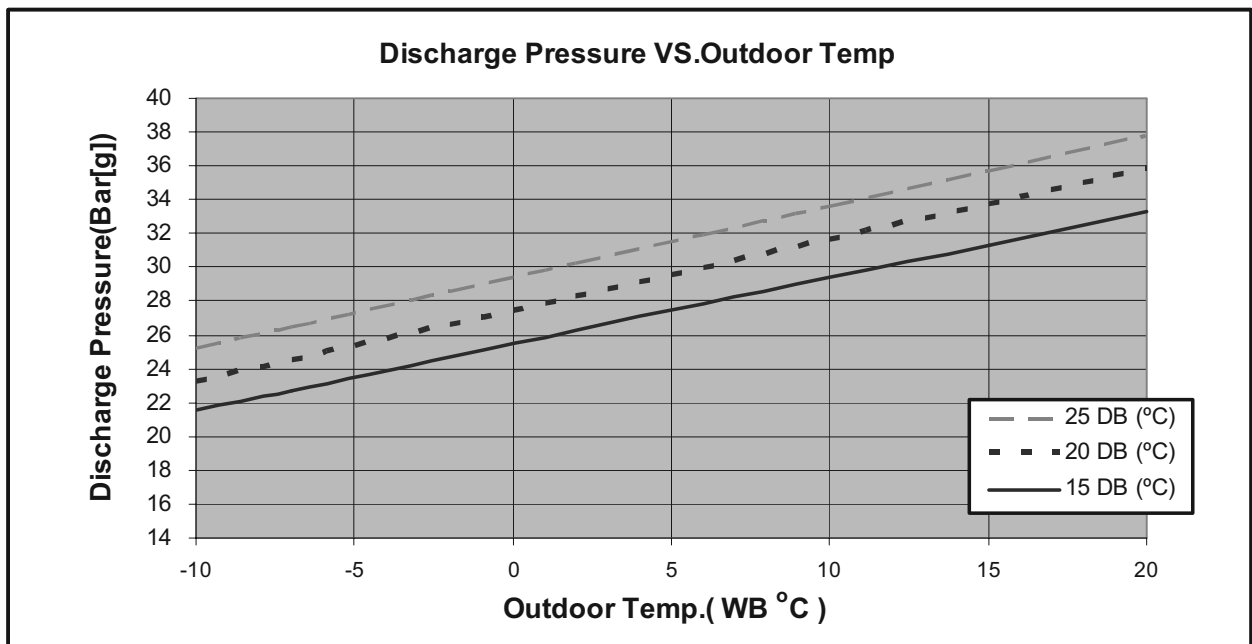
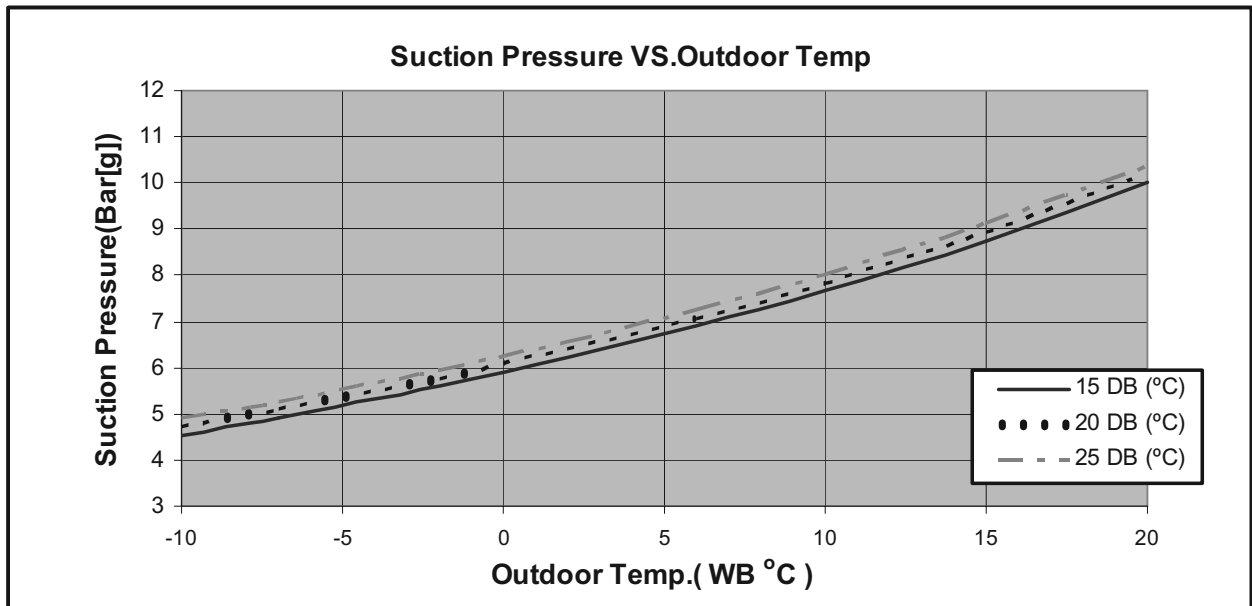

6. SOUND LEVEL CHARACTERISTICS

6.1 Sound Pressure Level

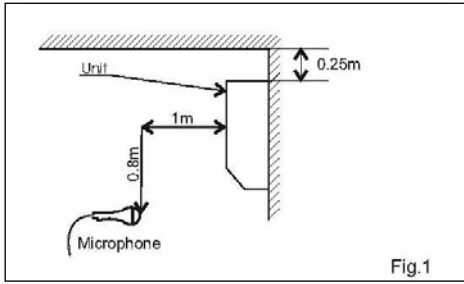

Figure 1. Wall Mounted

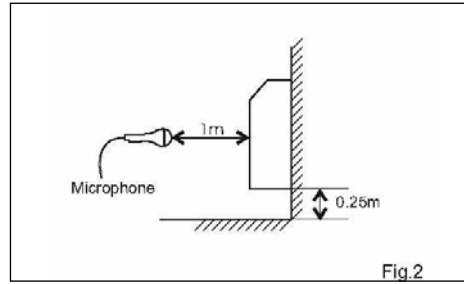

Figure 2. Floor Mounted

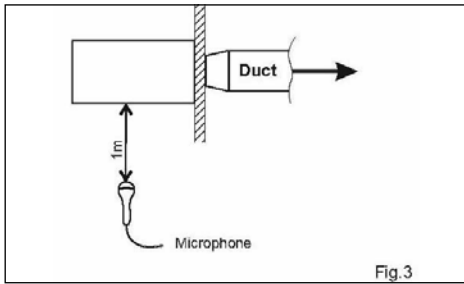

Figure 3. Ducted

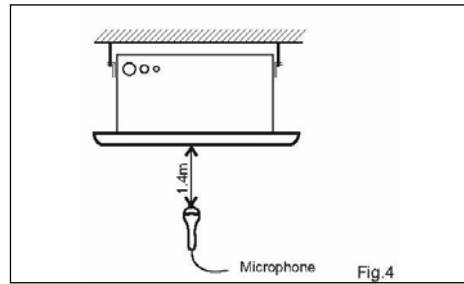
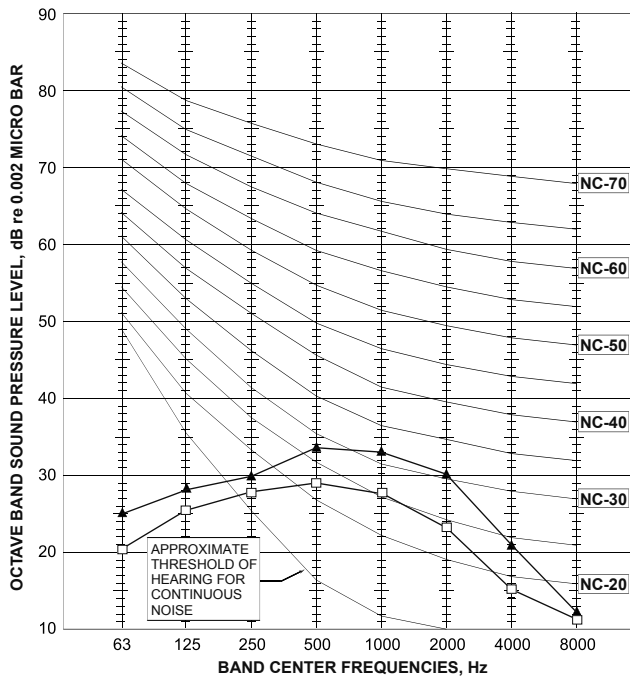

Figure 4. Cassette

6.2 Sound Pressure Level Spectrum (Measured as Figure 1)

Alpha 7



Alpha 9

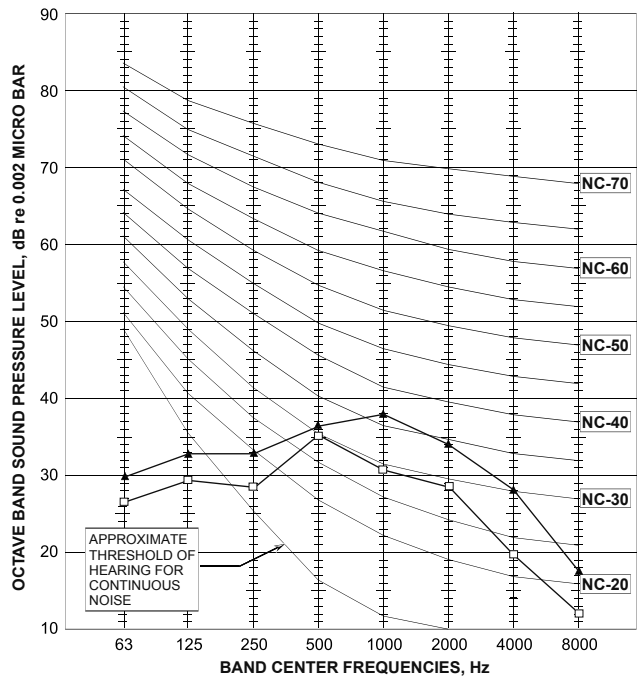

FAN SPEED	LINE
HI	—▲—
LO	—□—

Alpha 12

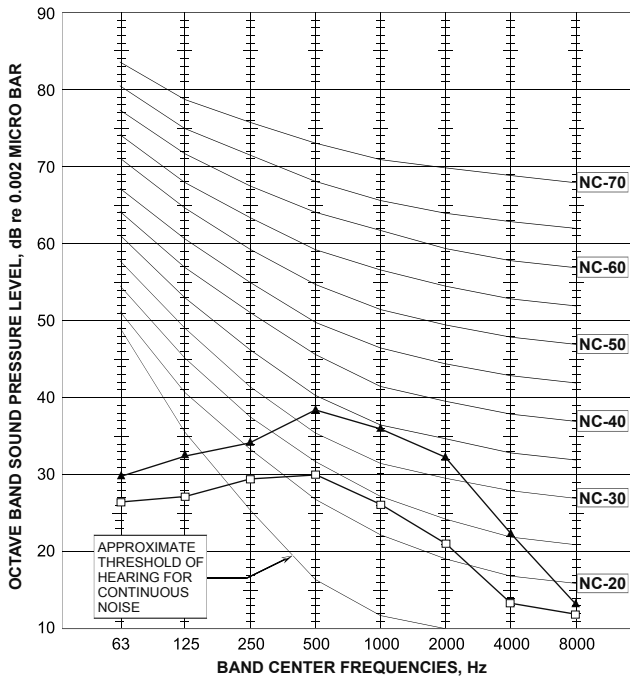

Alpha 17

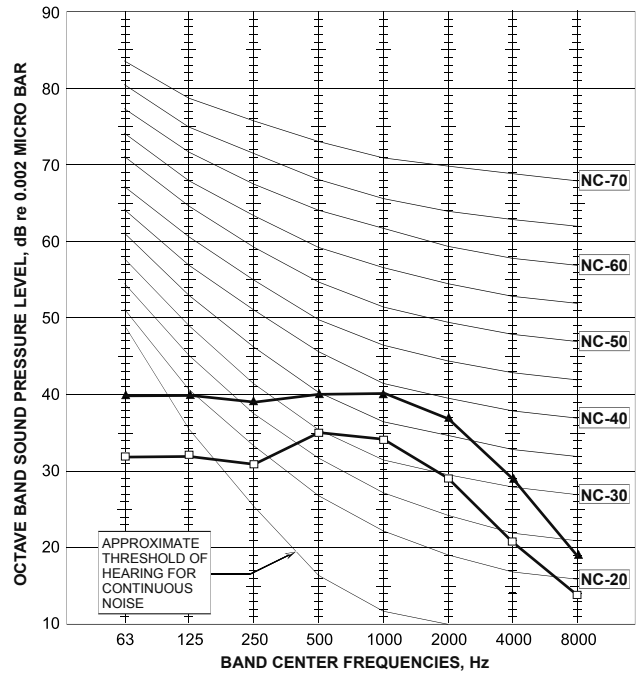

Alpha 7 DF

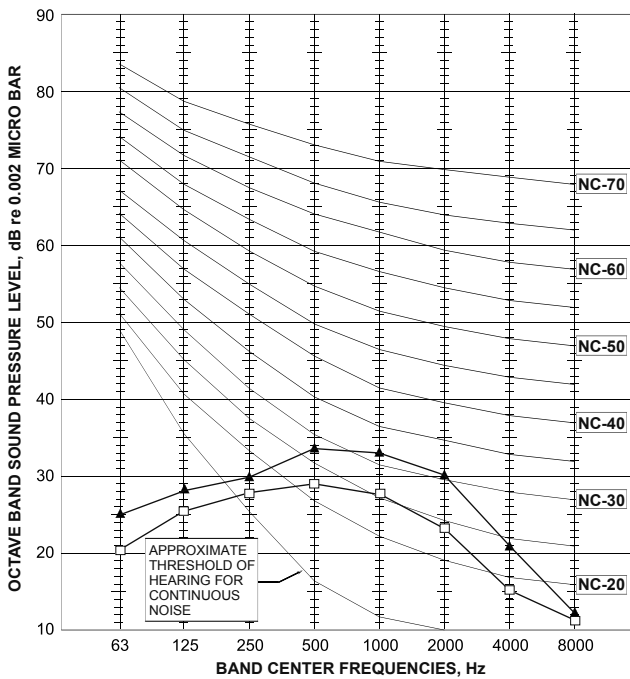

Alpha 9 DF

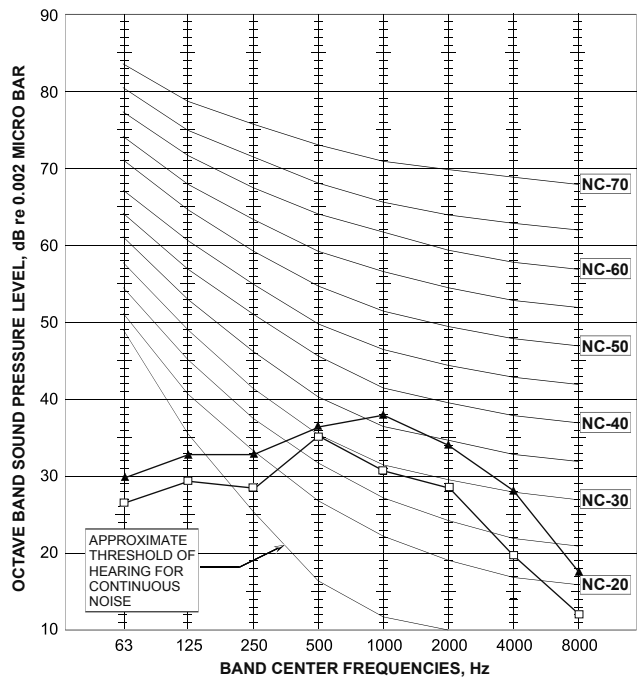

FAN SPEED	LINE
HI	—▲—
LO	—□—

Alpha 12 DF

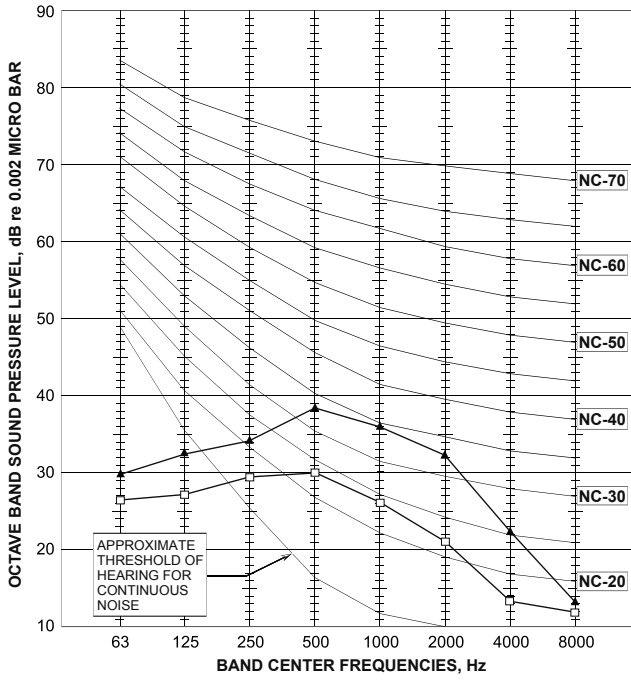

Delta 17

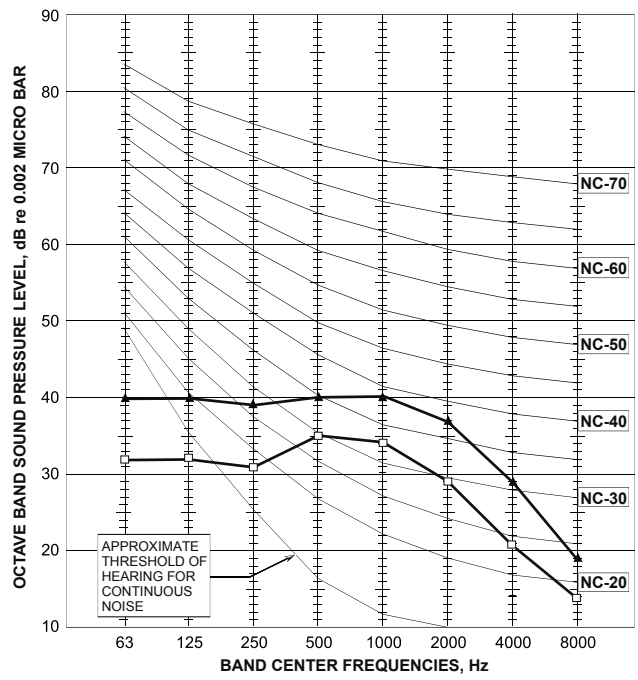

FAN SPEED	LINE
HI	—▲—
LO	—□—

6.3 Outdoor units

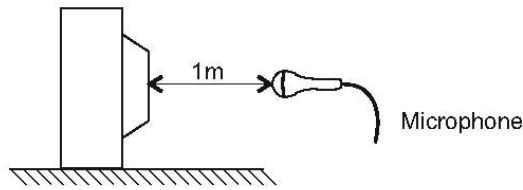

Fig.5

Microphone Distance from Unit

6.4 Sound Pressure Level Spectrum (Measured as Figure 5)

CON 7 Cooling

CON 7 Heating

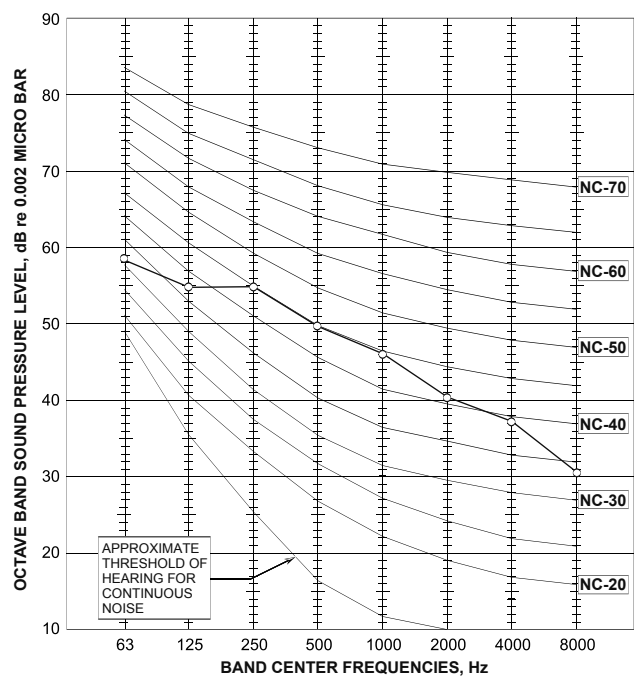
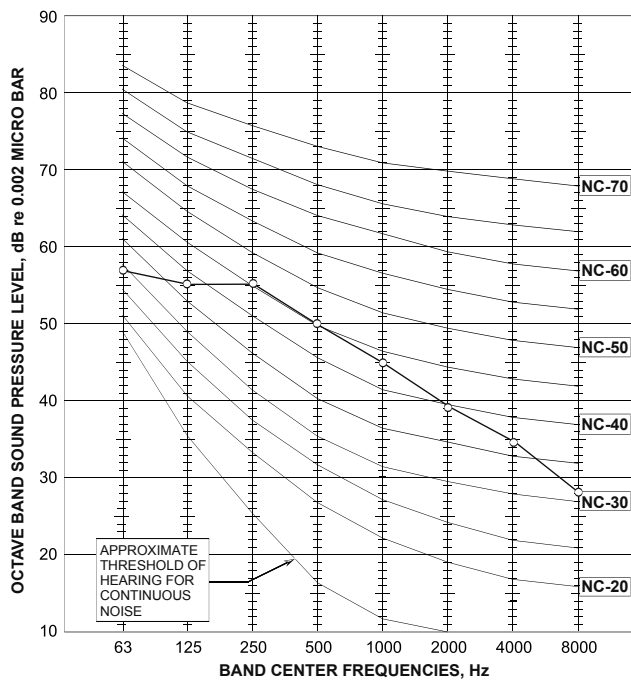

FAN SPEED	LINE
HI	—▲—
LO	—□—

GCN 9 Cooling

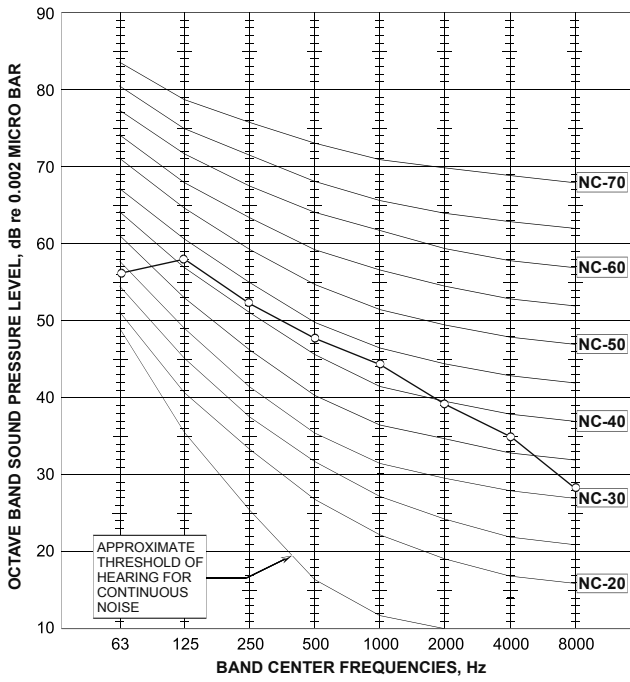

GCN 9 Heating

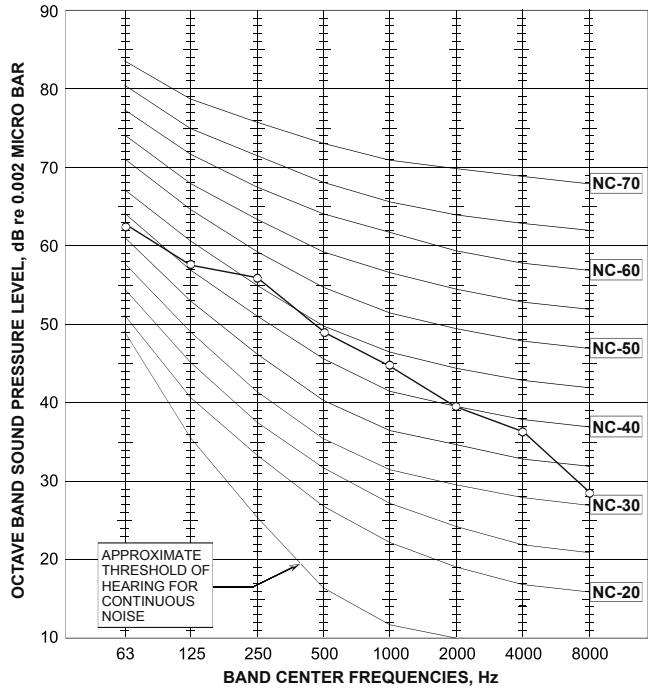

GCN 12 Cooling

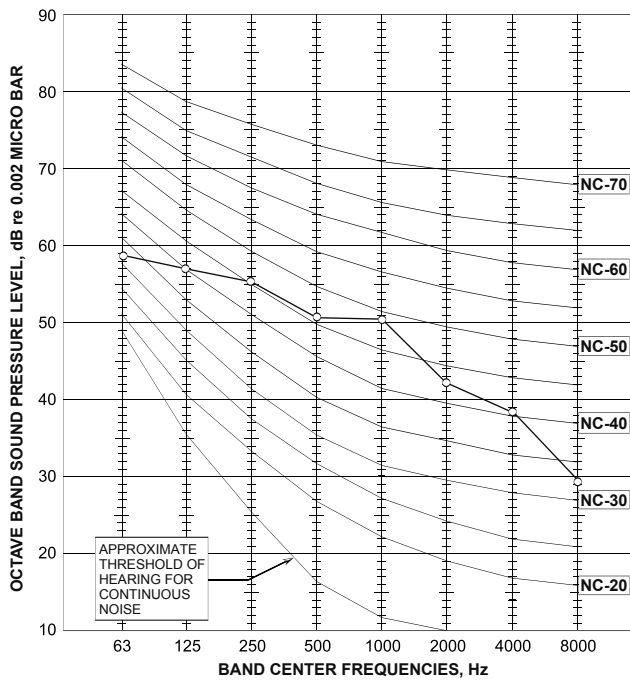

GCN 12 Heating

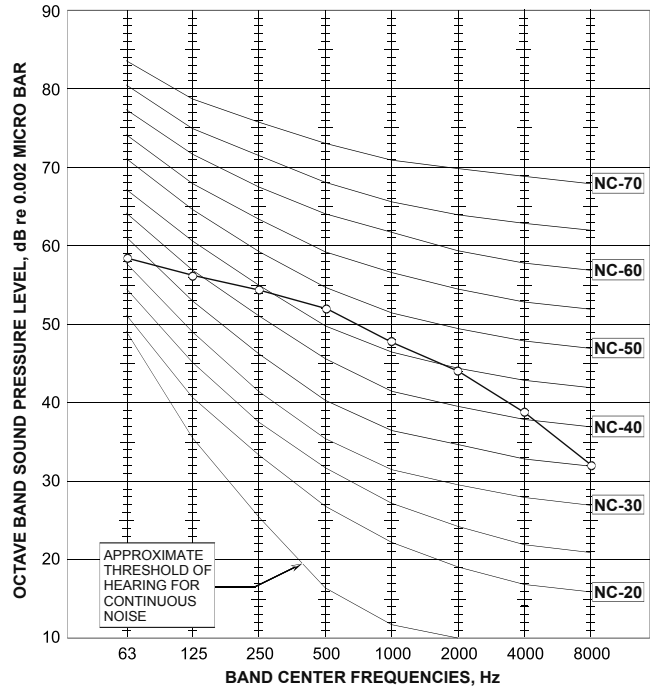

FAN SPEED	LINE
HI	—▲—
LO	—□—

ONG3-17 Cooling

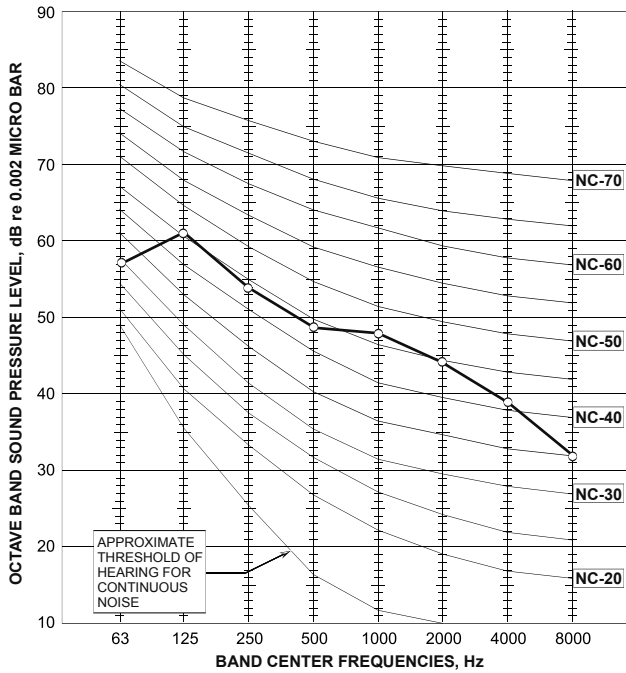

ONG3-17 Heating

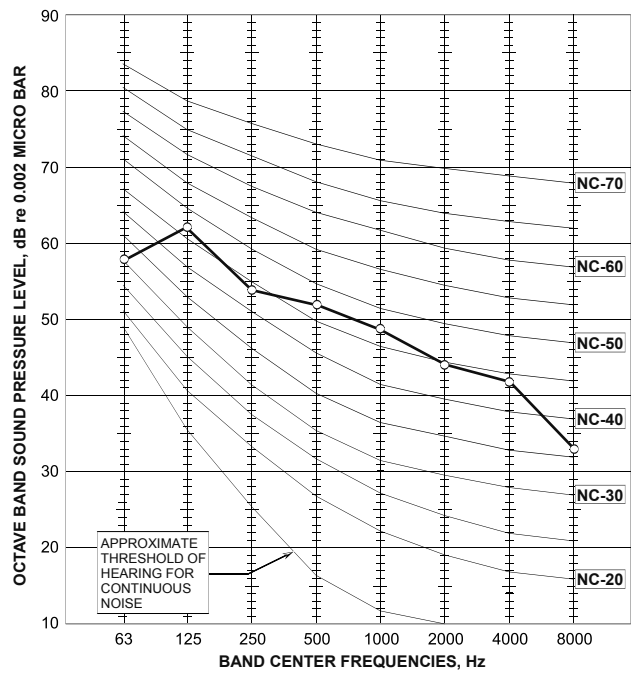

GCN 7 Cooling

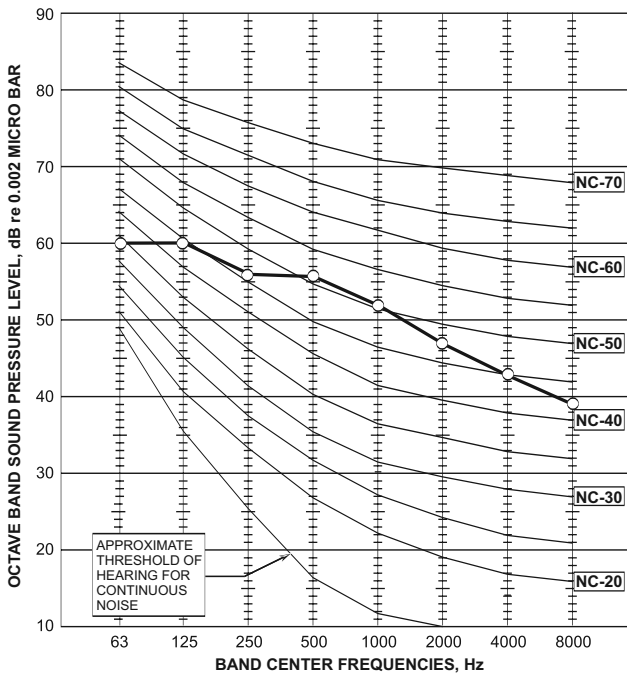

GCN 7 Heating

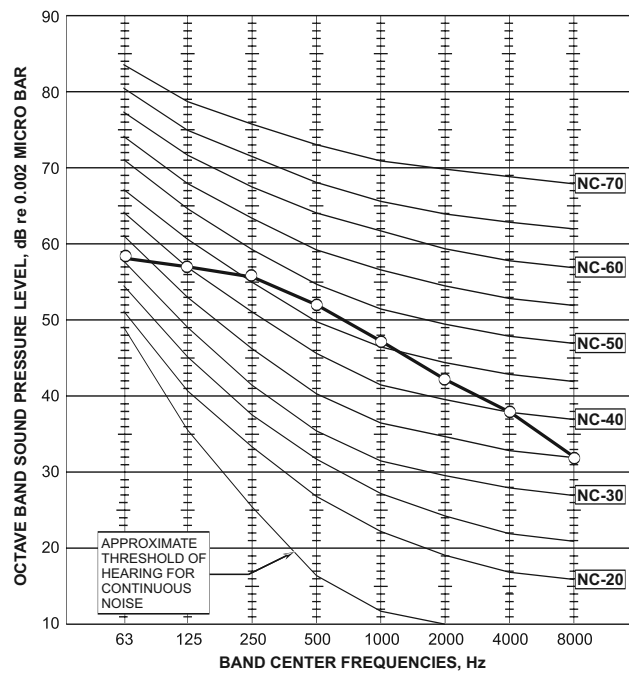

FAN SPEED	LINE
HI	—▲—
LO	—□—

ONG3-9 Cooling

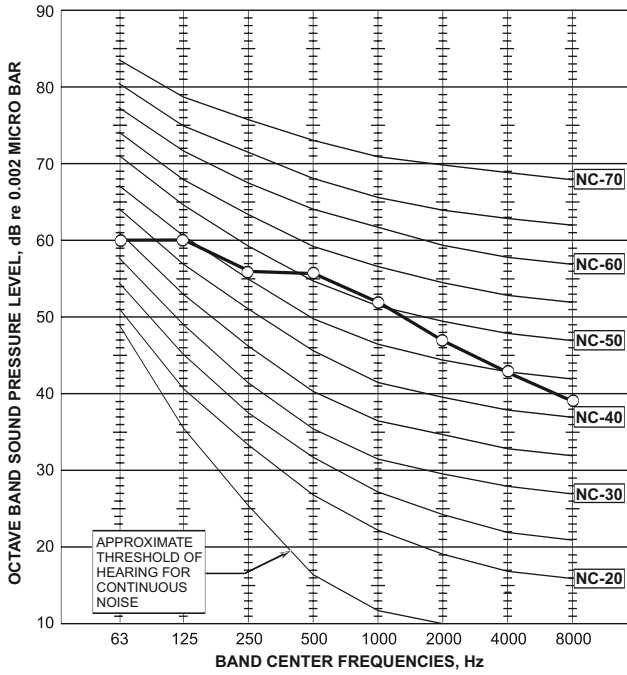

ONG3-9 Heating

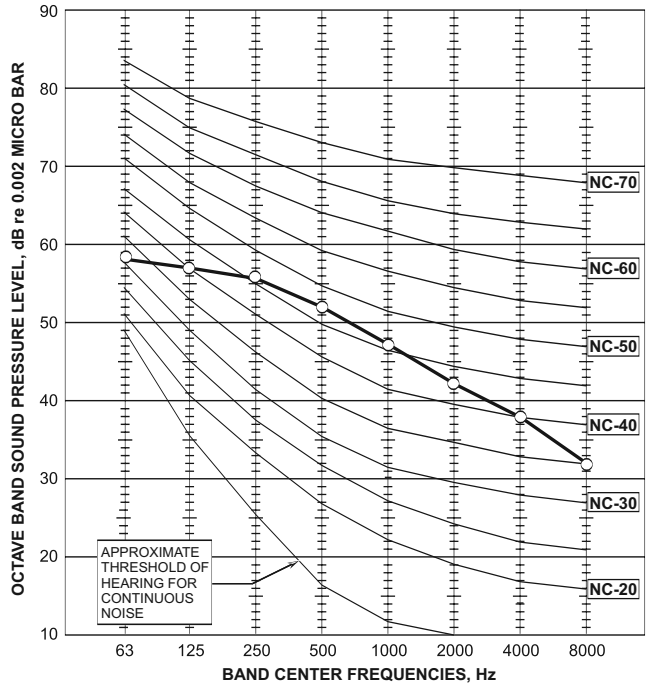

ONG3-12 Cooling

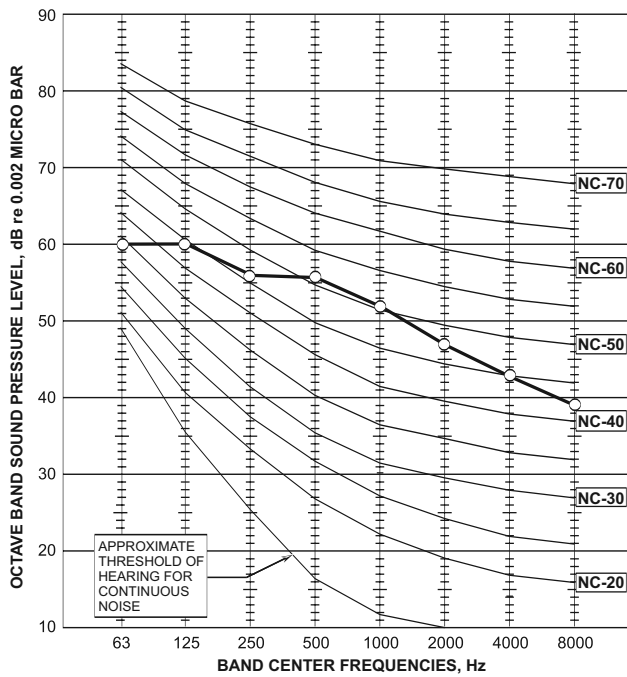

ONG3-12 Heating

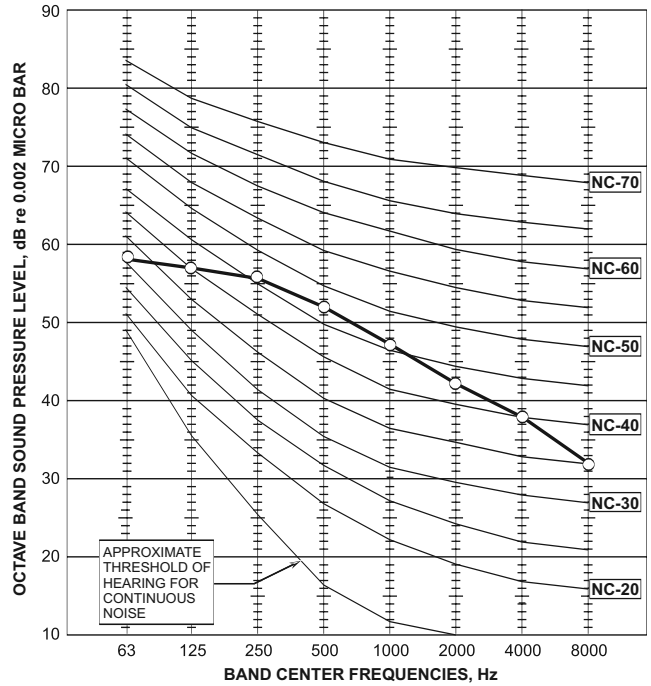

FAN SPEED	LINE
HI	—▲—
LO	—□—

ONG3-14 Cooling

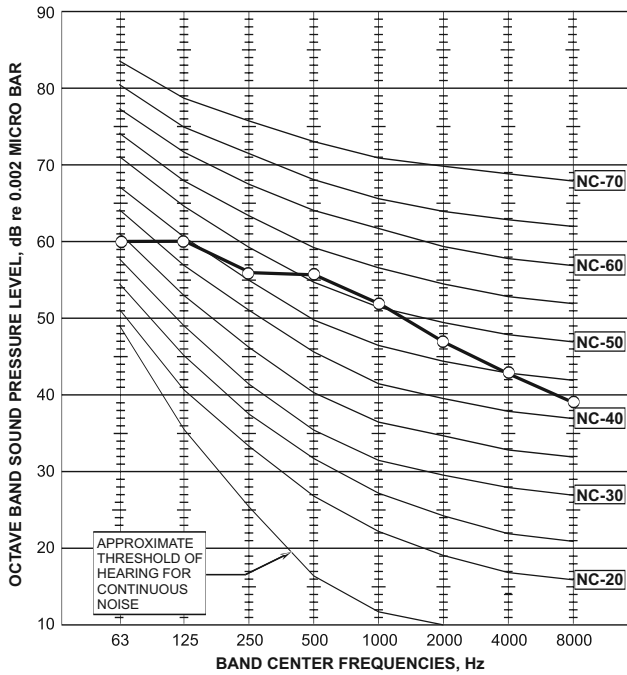

ONG3-14 Heating

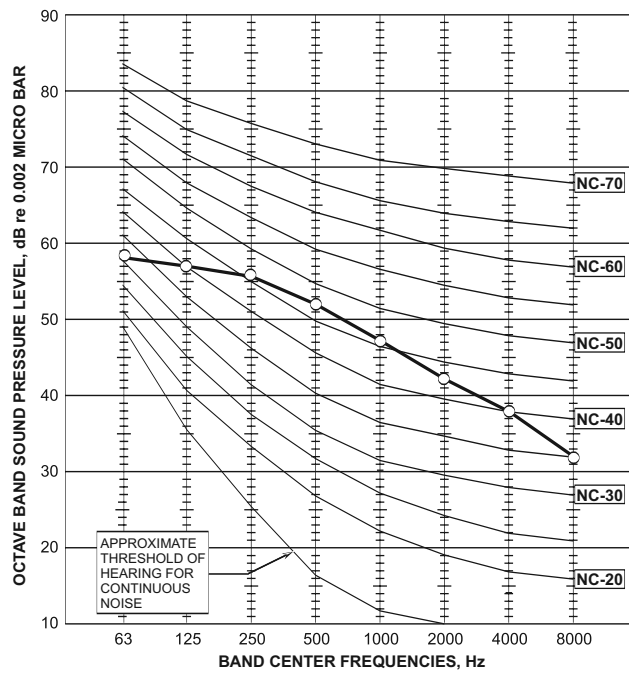

ONG3-17 Cooling

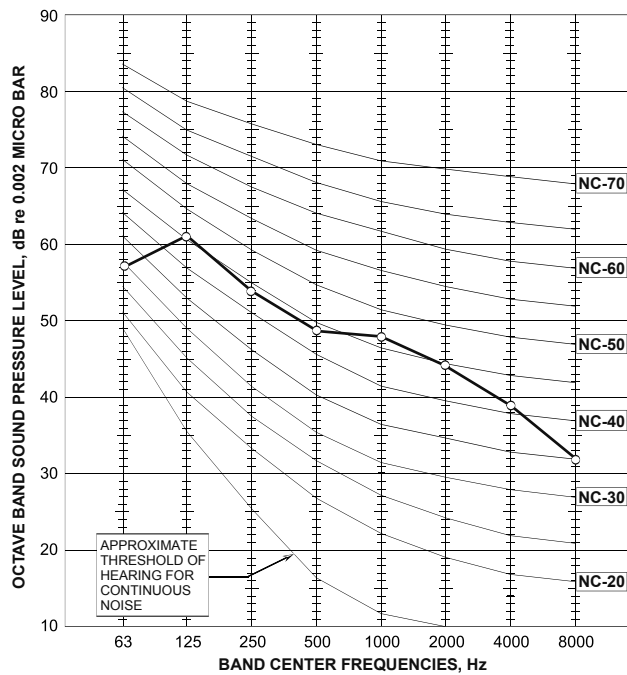

ONG3-17 Heating

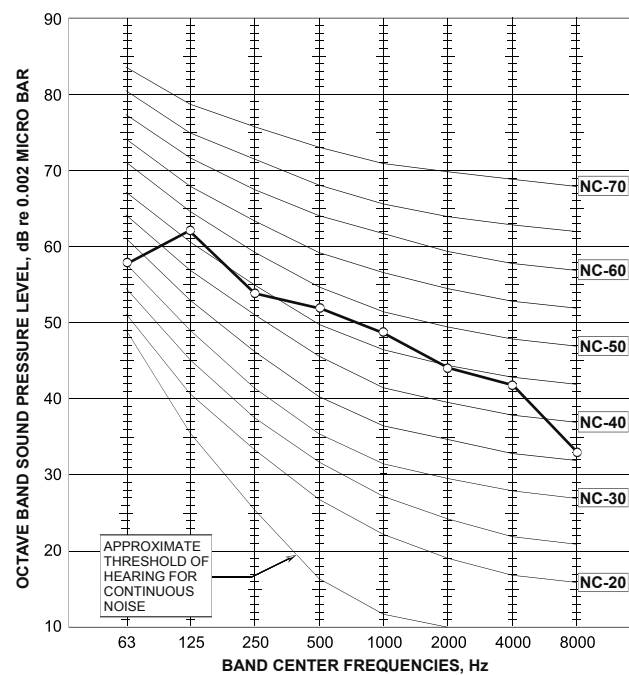

FAN SPEED	LINE
HI	—▲—
LO	—□—

7. ELECTRICAL DATA

7.1 Single Phase Units

MODEL	Alpha 7	Alpha 9
Power Supply	To indoor	To indoor
	1PH-230V-50Hz	1PH-230V-50Hz
Max Current, A	4.1	6.5
Circuit Breaker,A	10	10
Power Supply Wiring No. X Cross Section mm ²	3x1.0 mm ²	3x1.0 mm ²
Interconnecting Cable RC Model No. X Cross Section mm ²	5x1.0 mm ² +2x0.5 mm ² (OCT sensor)	5x1.0 mm ² +2x0.5 mm ² (OCT sensor)
Interconnecting Cable ST Model No. X Cross Section mm ²	4x1.0 mm ²	4x1.0 mm ²

MODEL	Alpha 12	Alpha 17 / Delta 17
Power Supply	To indoor	To indoor
	1PH-230V-50Hz	1PH-230V-50Hz
Max Current, A	7.7	10.4
Circuit Breaker,A	10	15
Power Supply Wiring No. X Cross Section mm ²	3x1.0 mm ²	3x1.5 mm ²
Interconnecting Cable RC Model No. X Cross Section mm ²	5x1.0 mm ² +2x0.5 mm ² (OCT sensor)	5x1.5 mm ² +2x0.5 mm ² (OCT sensor)
Interconnecting Cable ST Model No. X Cross Section mm ²	4x1.0 mm ²	4x1.5 mm ²

MODEL	Delta 24
Power Supply	To outdoor
	1PH-230V-50Hz
Max Current, A	14.0
Circuit Breaker,A	20
Power Supply Wiring No. X Cross Section mm ²	3x2.5 mm ²
Interconnecting Cable RC Model No. X Cross Section mm ²	6x1.5 mm ² +2x0.5 mm ² (OCT sensor)
Interconnecting Cable ST Model No. X Cross Section mm ²	5x1.5 mm ² +2x0.5 mm ²

NOTE

Power wiring cord should comply with local laws and electrical regulations requirements.

8. WIRING DIAGRAMS

8.1 Indoor Unit: Alpha / Delta 7,9,12

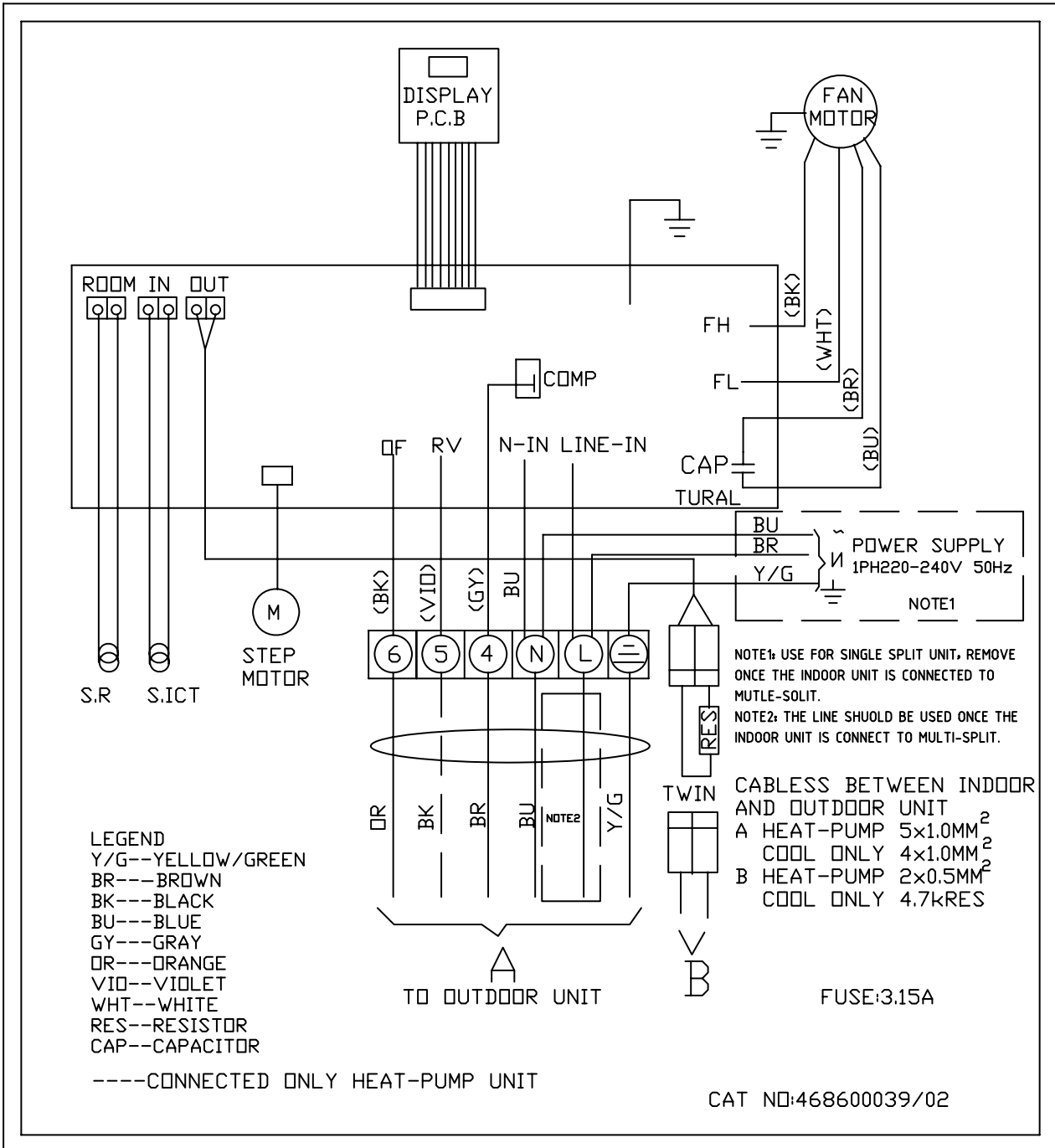

8.2 Indoor Unit: Delta 17, 24

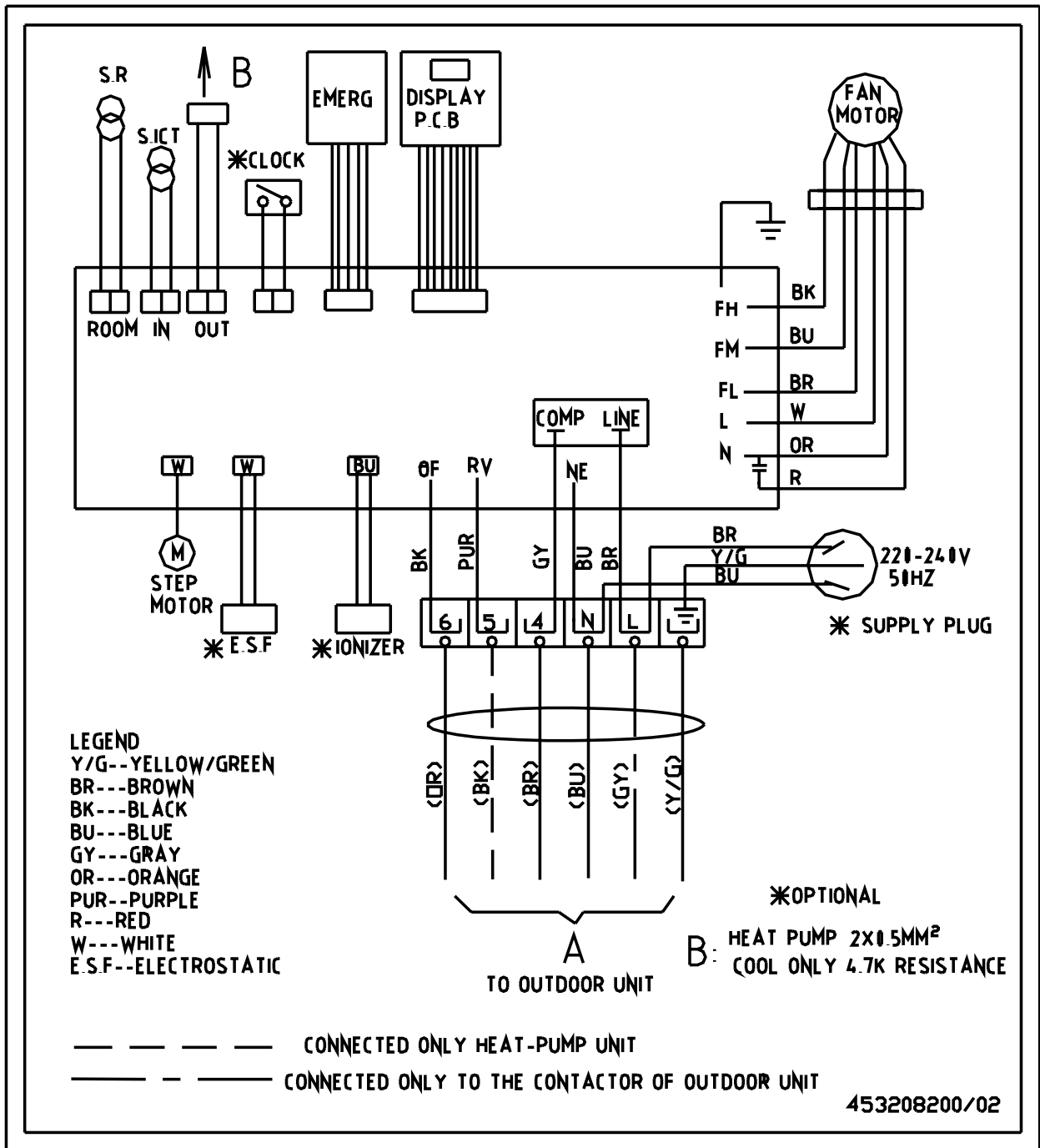

8.2 Outdoor Unit: CON 7

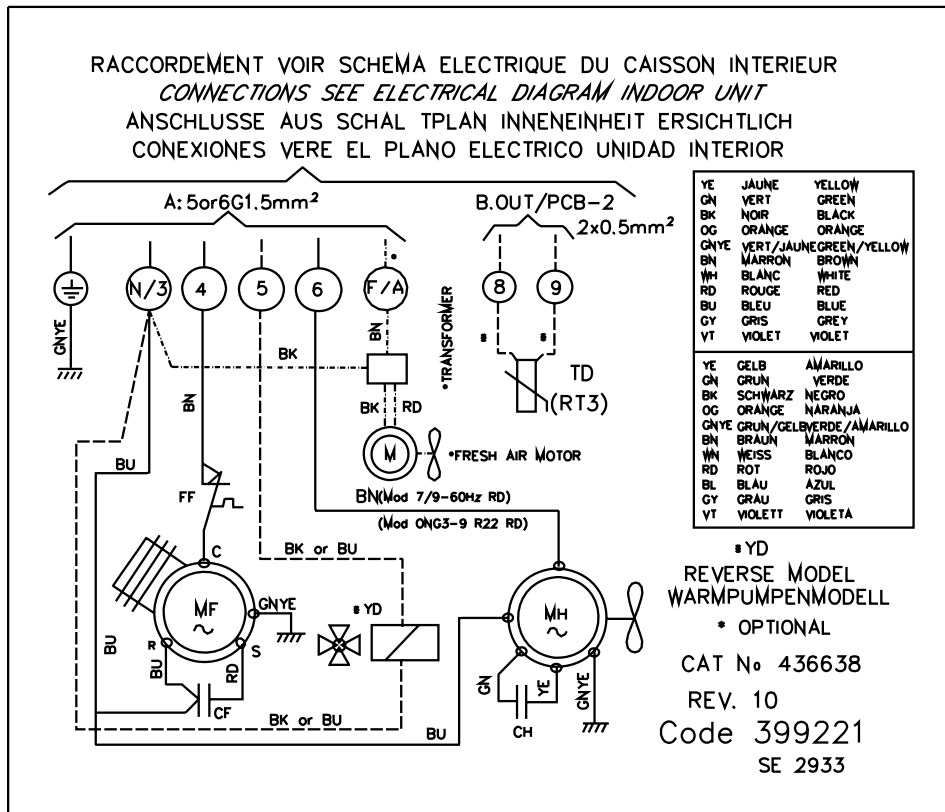

8.3 Outdoor Unit: CON 7 with easy connection kit

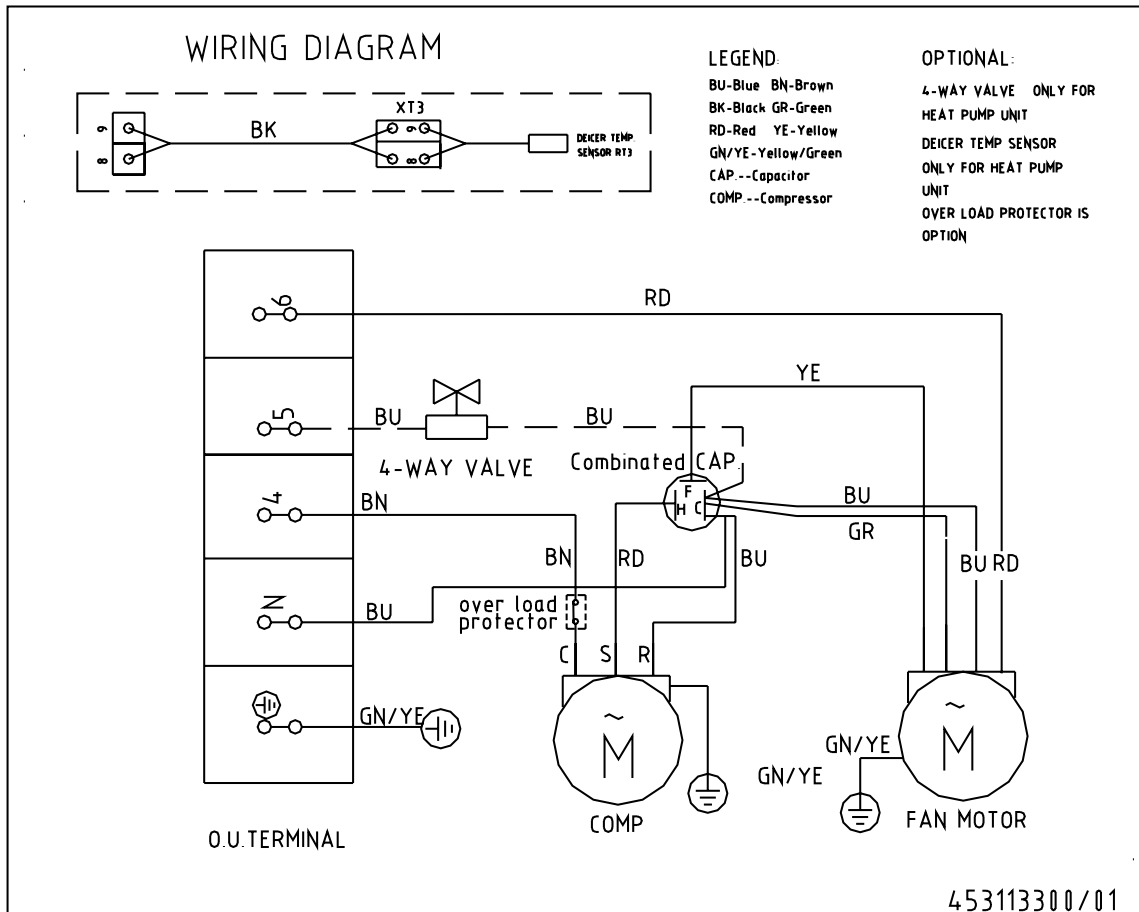

8.4 Outdoor Unit: GCN 7, 9, 12

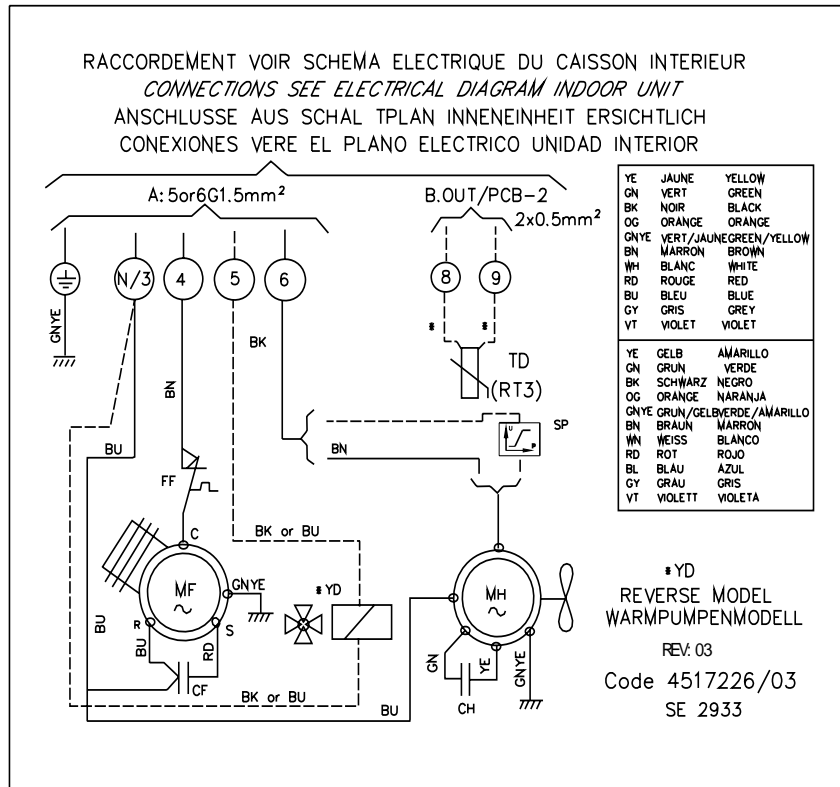

8.5 Outdoor Unit: GCN 9,12 with easy connection kit

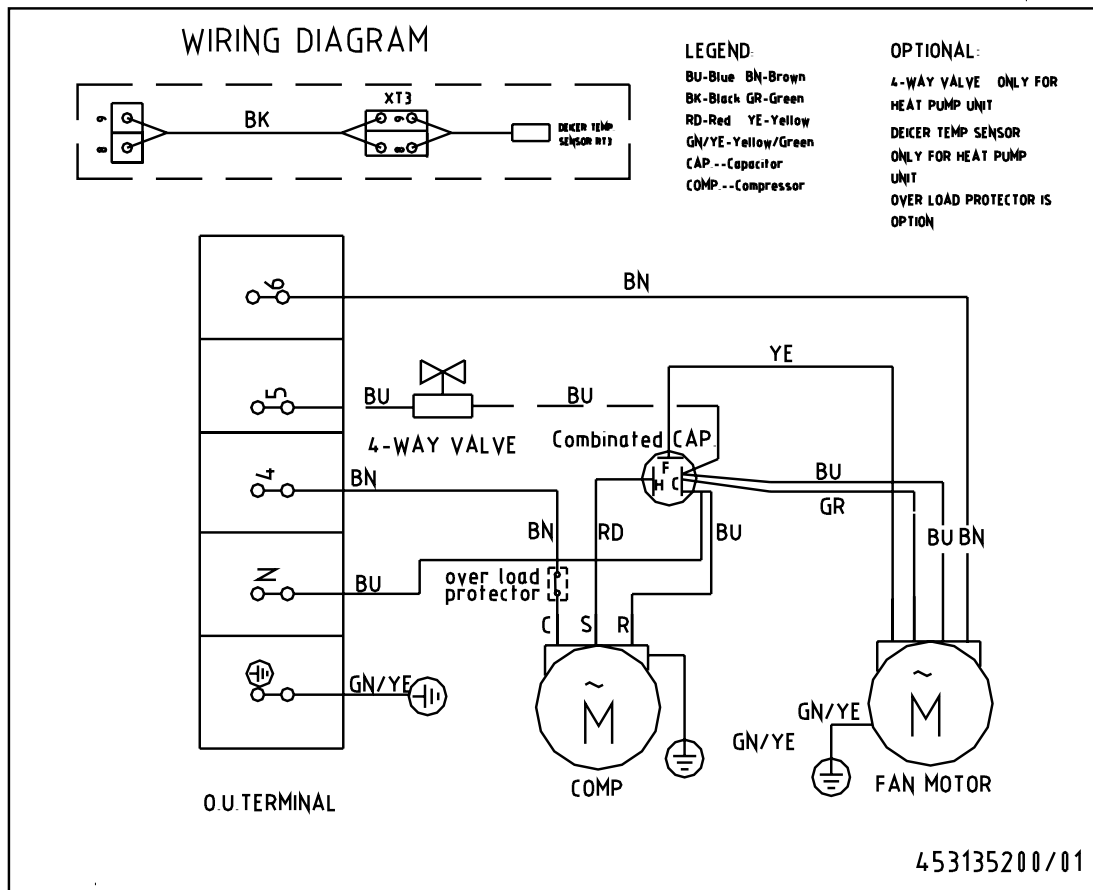

8.6 Outdoor Unit: ONG3-9, 12, 14, 17

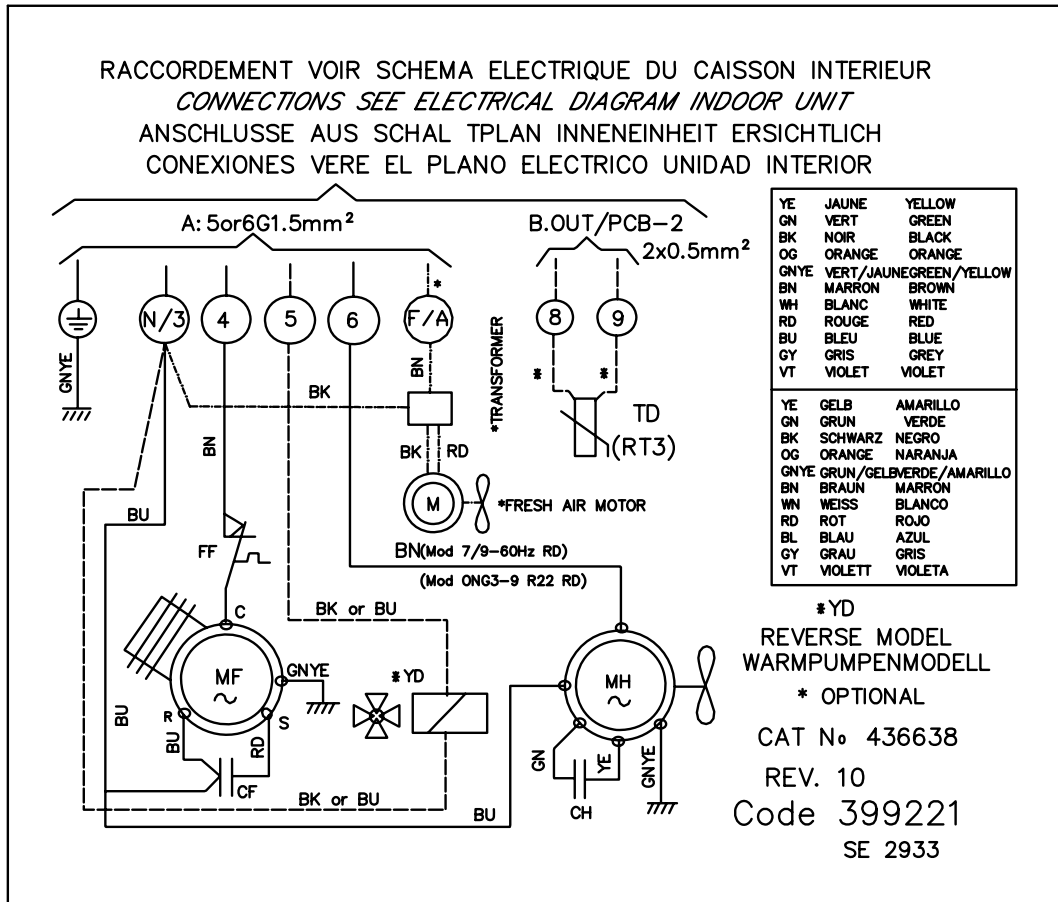

8.6 Outdoor Unit: OU7-24C

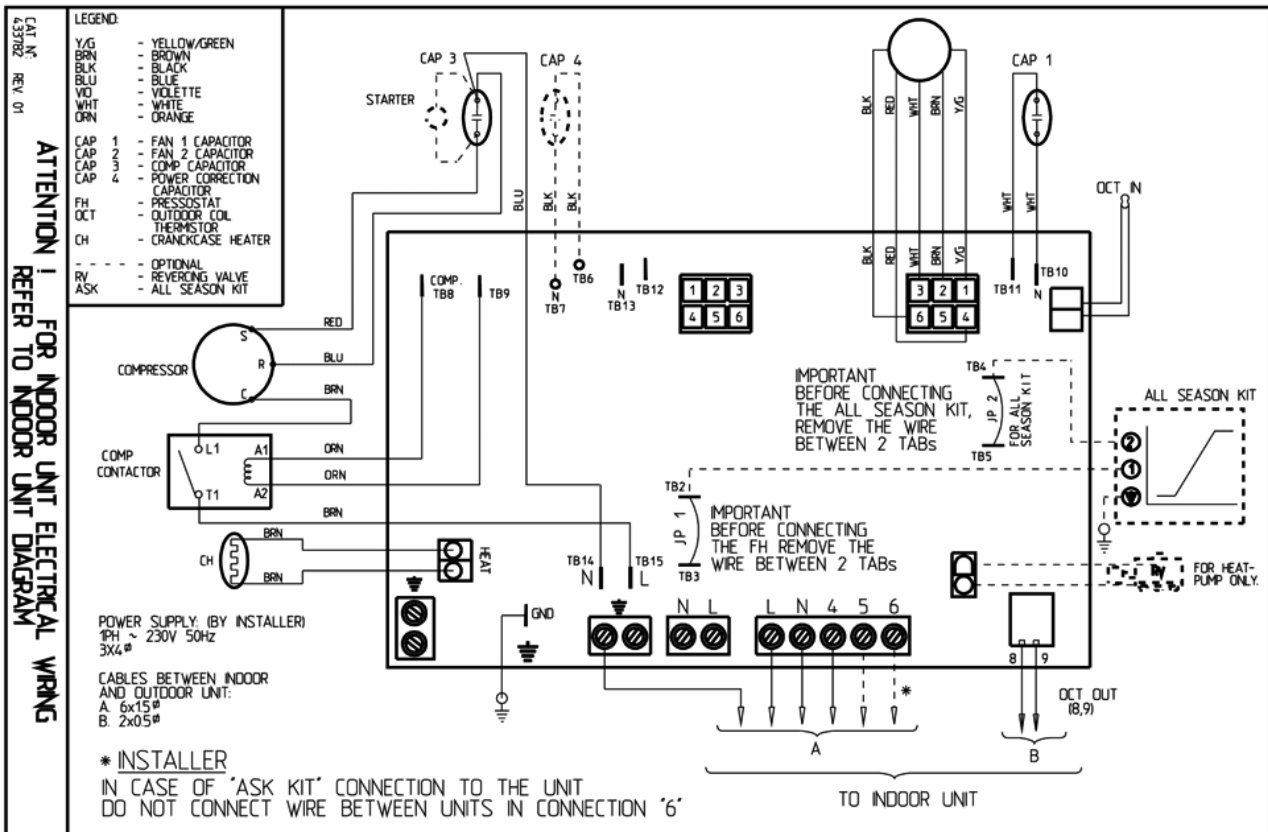

9. ELECTRICAL CONNECTIONS

9.1 Alpha / Delta 7,9,12,17

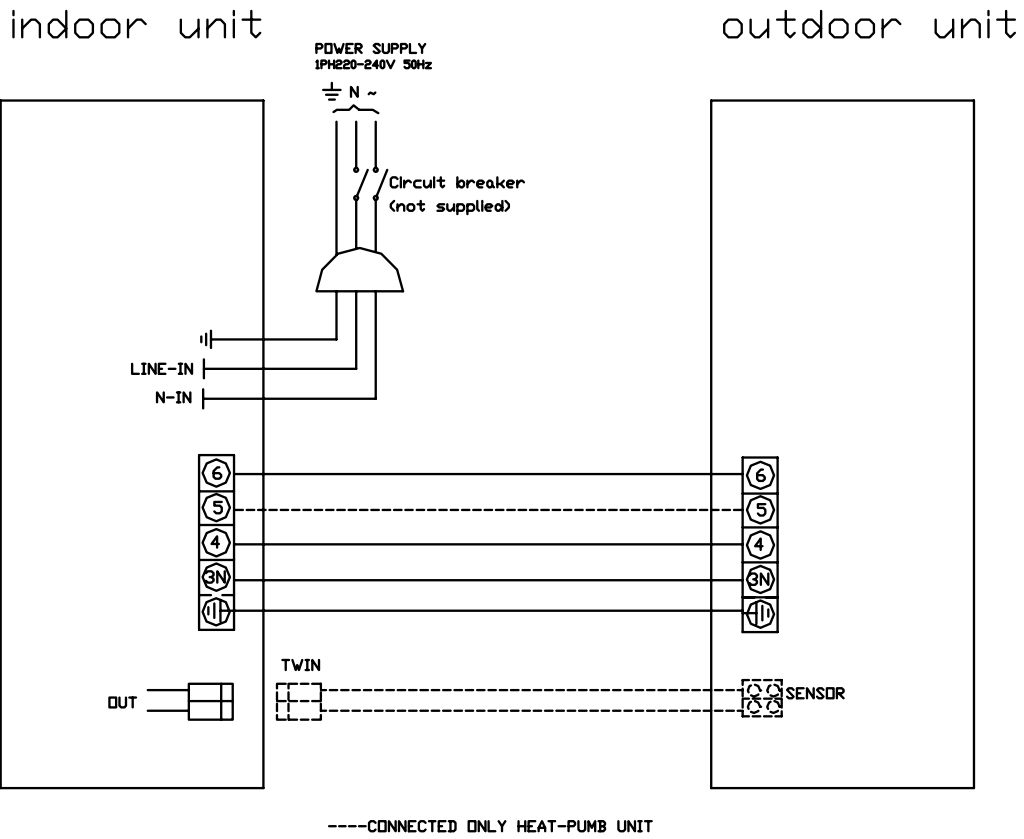

9.2 Delta 24

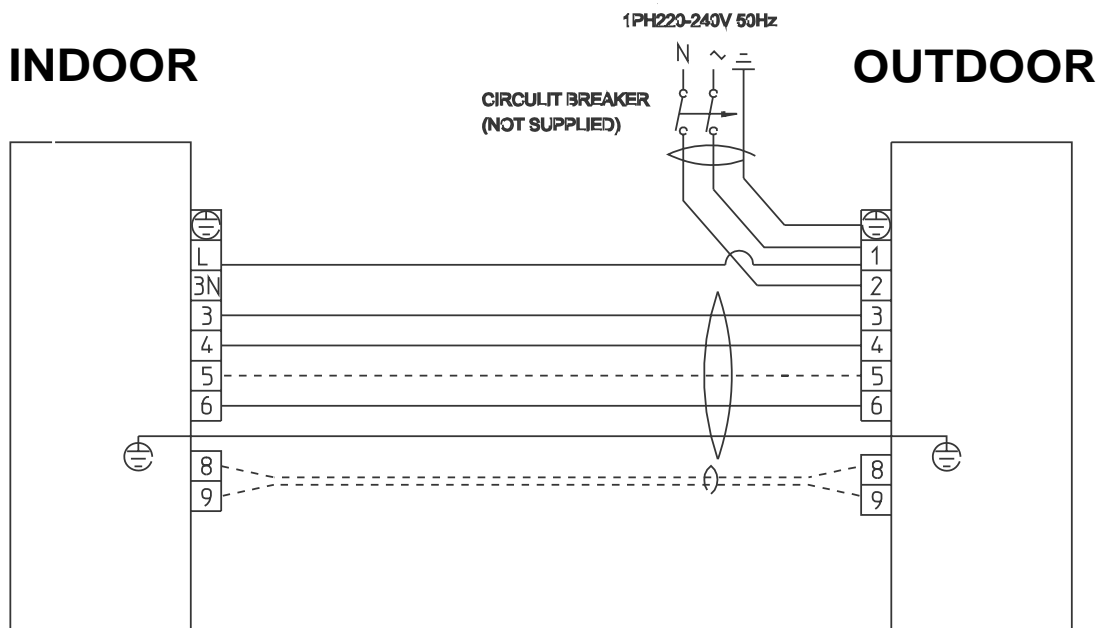

10. REFRIGERATION DIAGRAMS

10.1 Heat Pump Models

10.1.1 Alpha / Delta 7, 9, 12, 17 RC

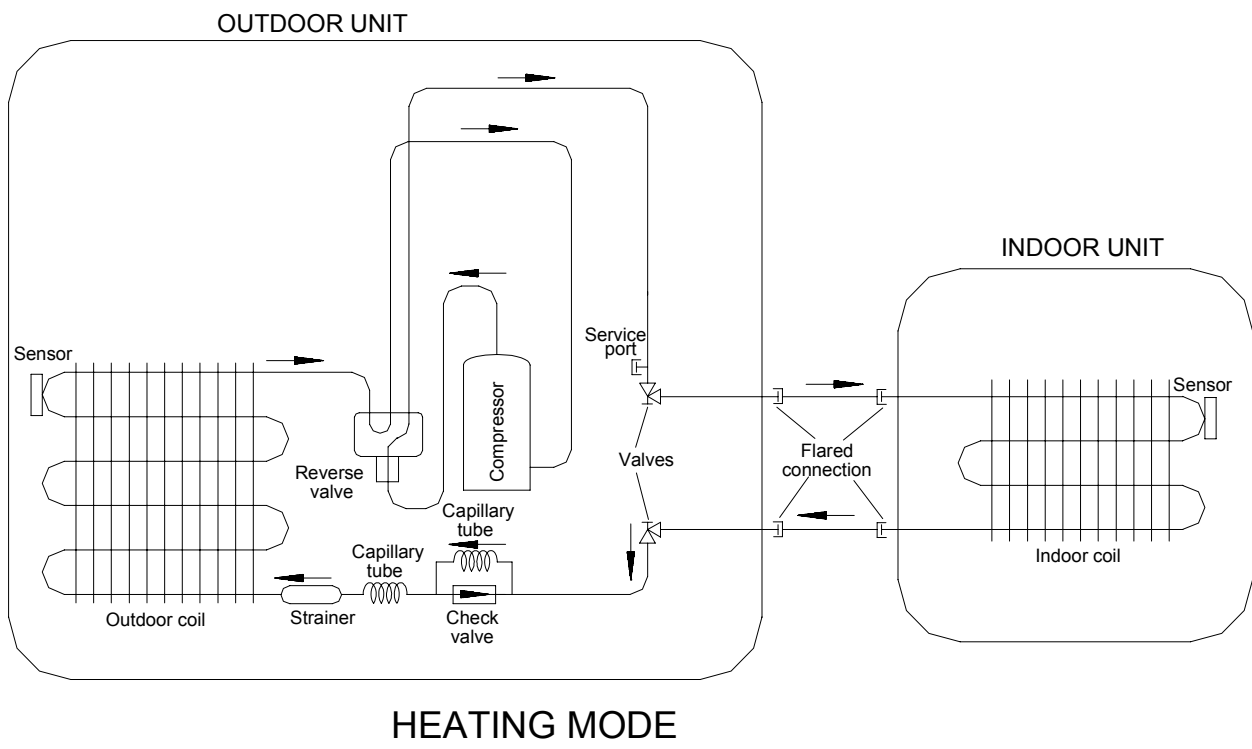
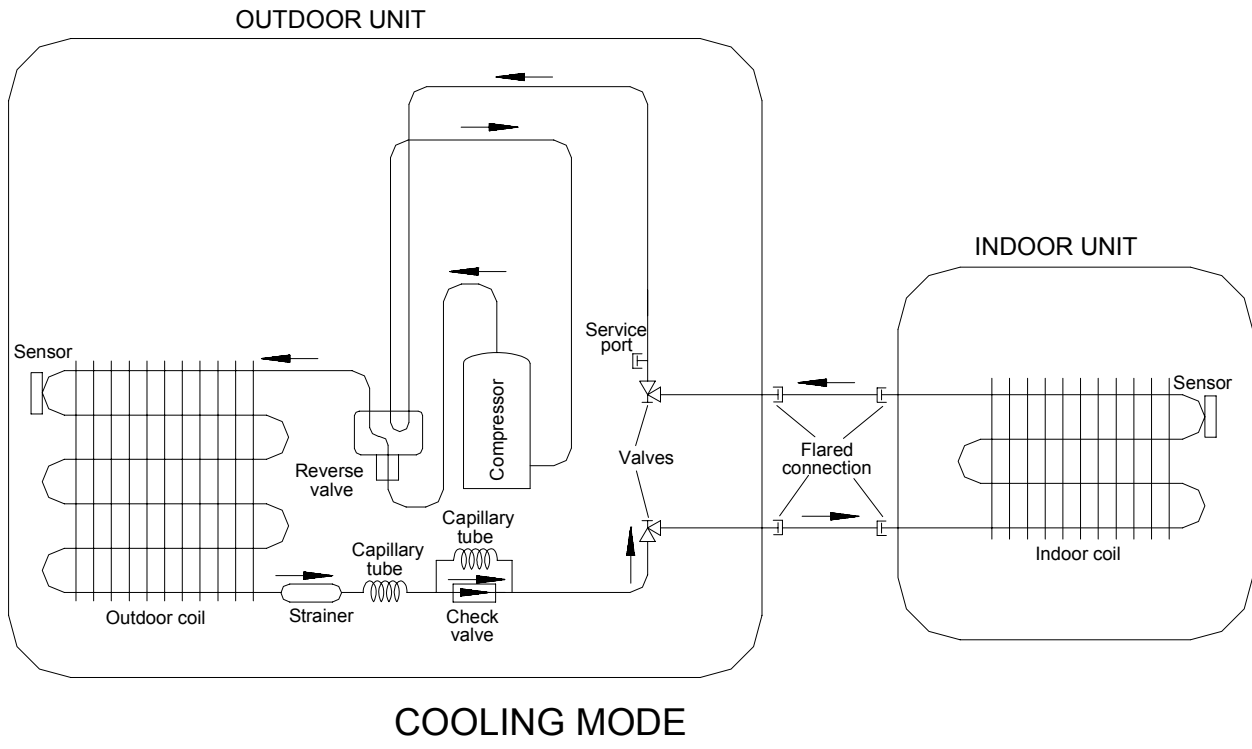

10.1.2 Delta 17 / ONG3-17

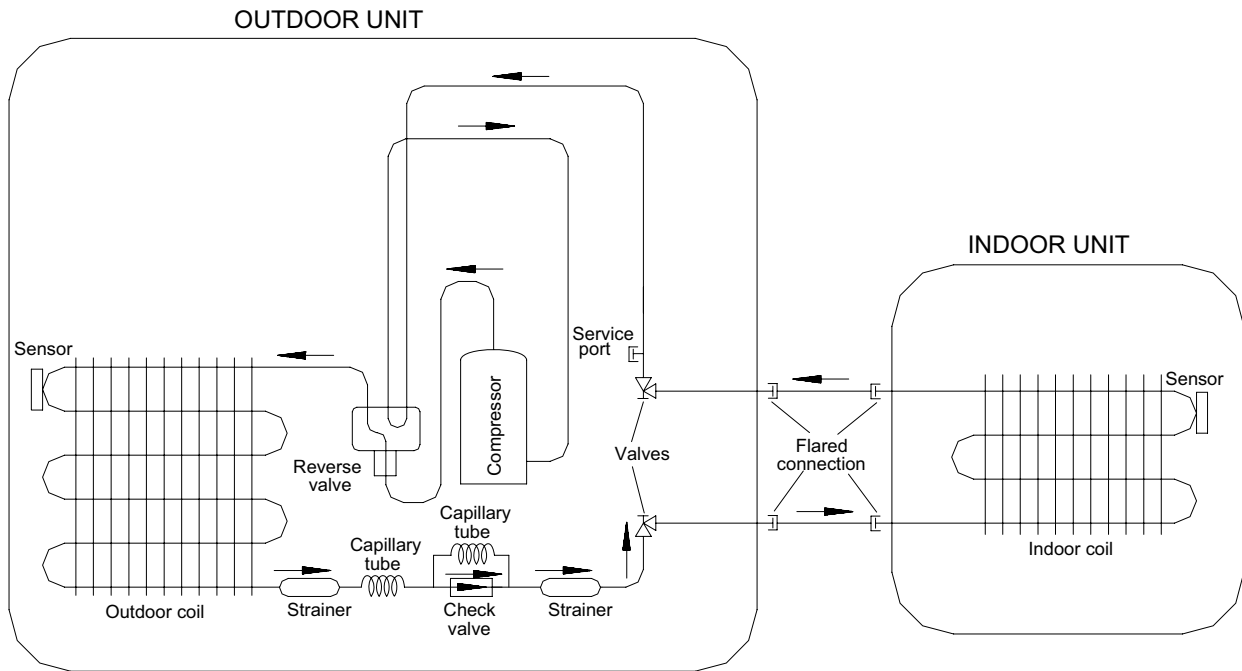

COOLING MODE

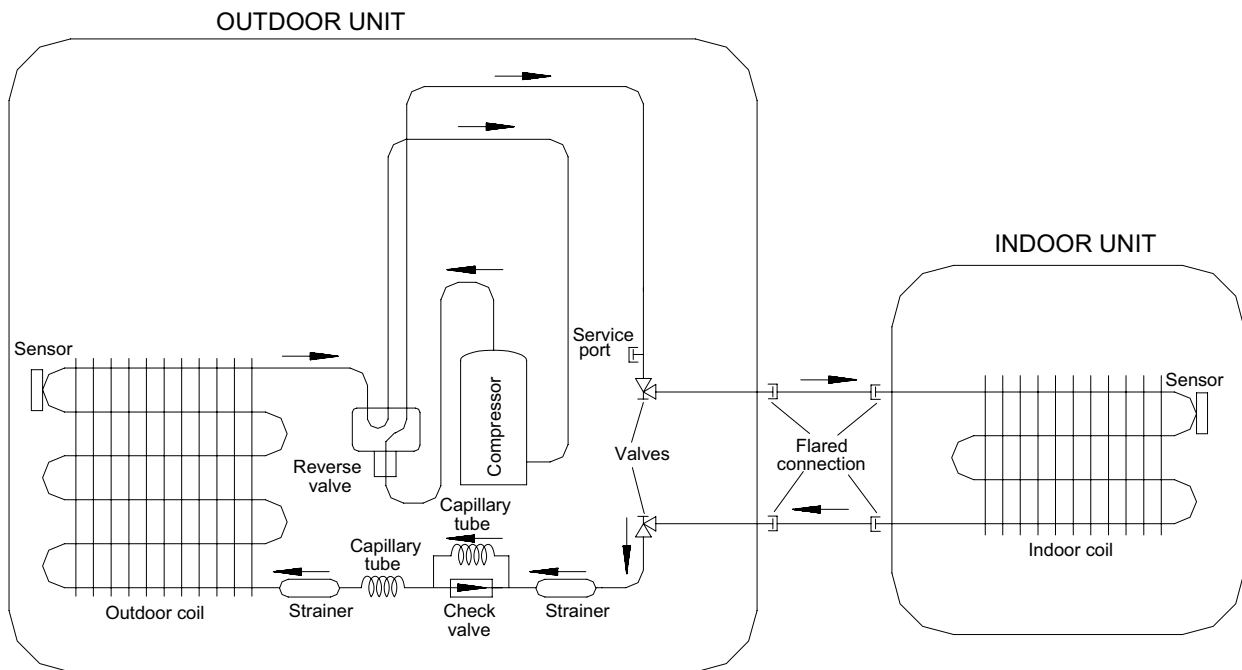

HEATING MODE

10.1.3 Delta 24 / OU7-24C

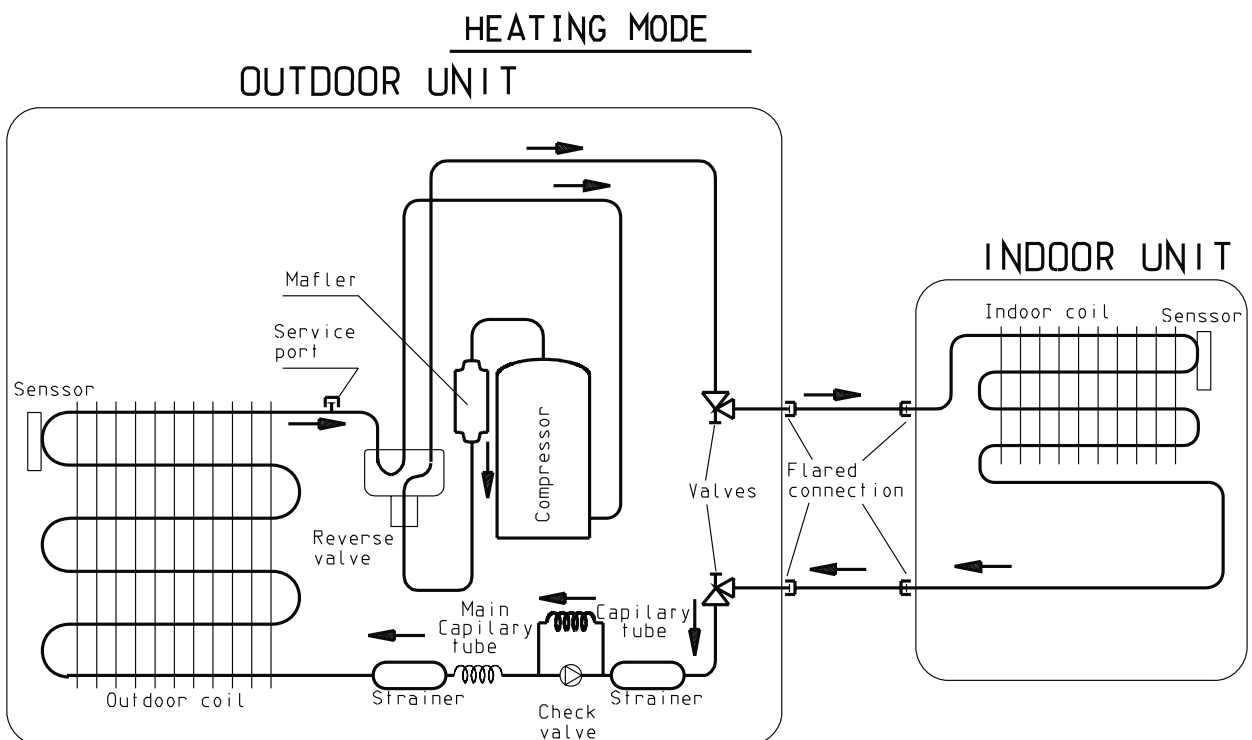
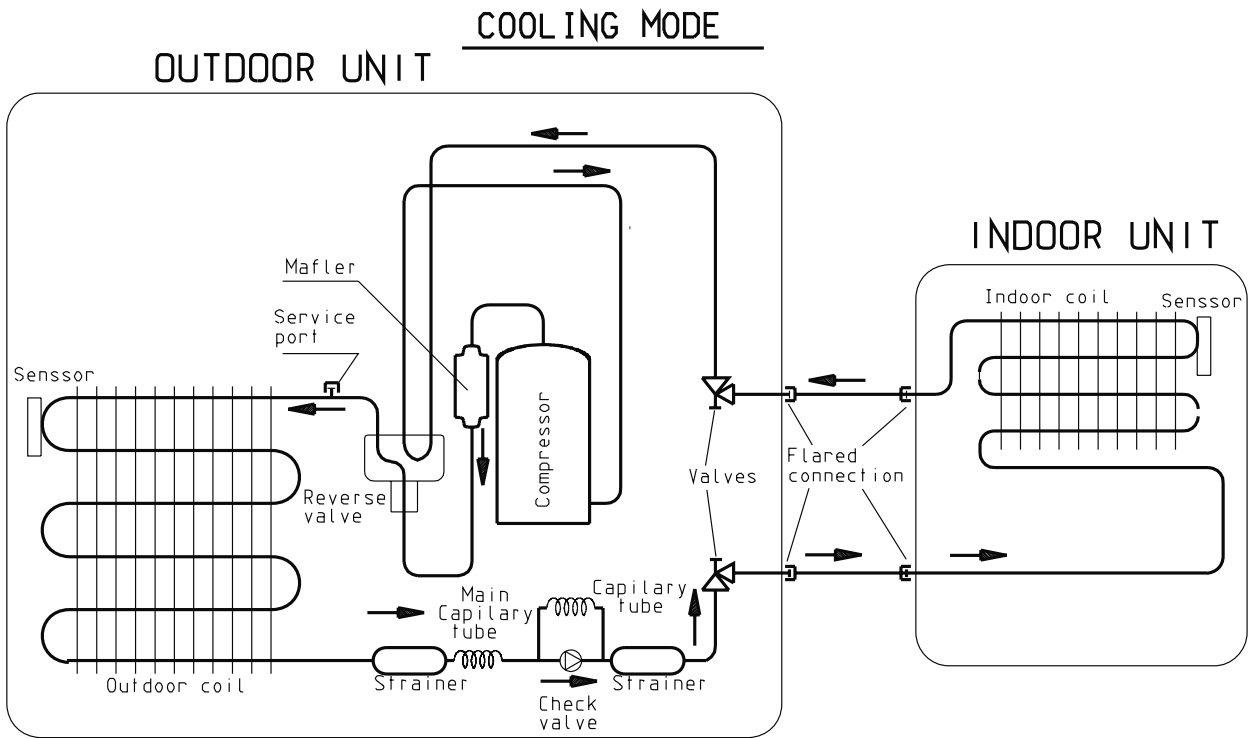

10.2 Cooling Only Models

10.2.1 All Models

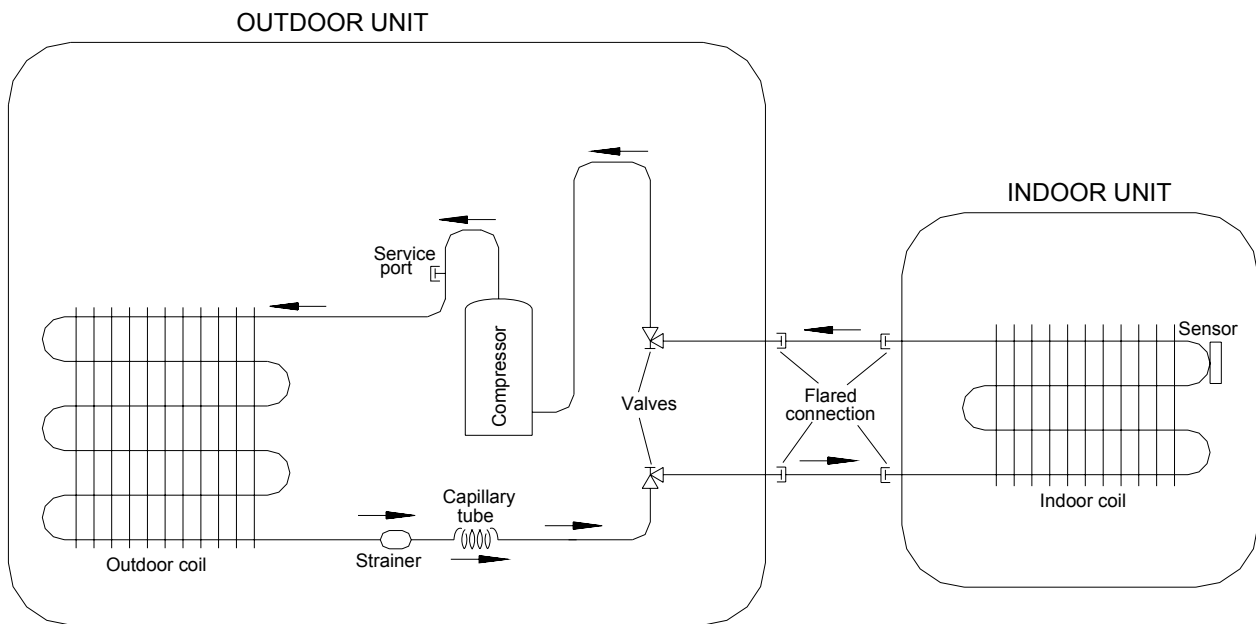

11. TUBING CONNECTIONS

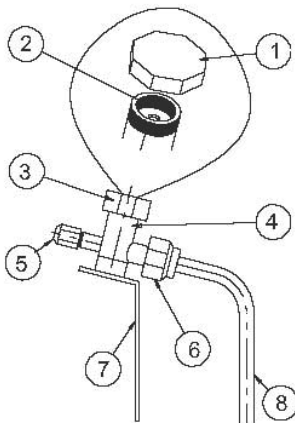
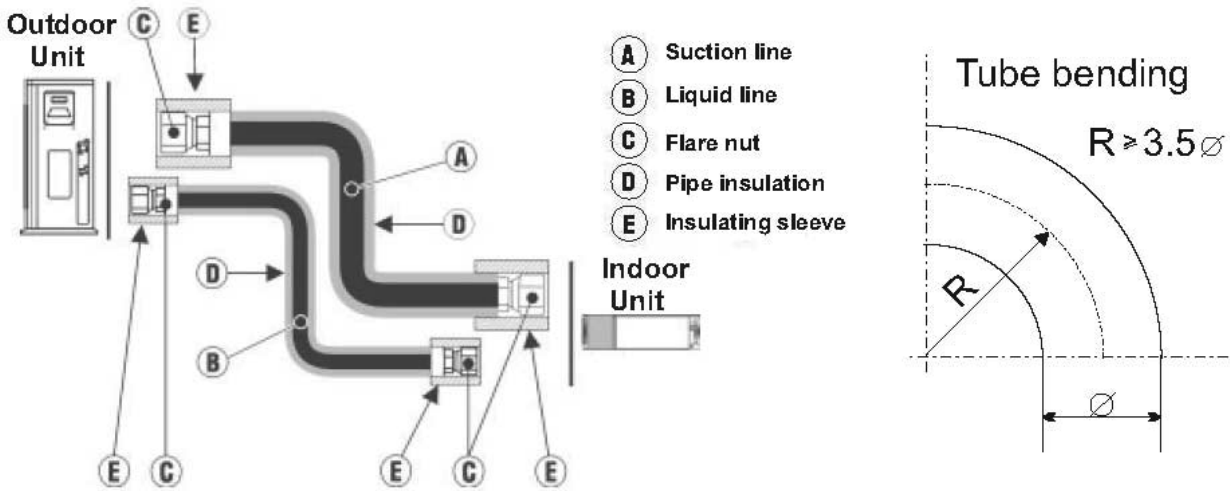

TUBE (Inch)	1/4"	3/8"	1/2"	5/8"	3/4"
TORQUE (Nm)					
Flare Nuts	11-13	40-45	60-65	70-75	80-85
Valve Cap	13-20	13-20	18-25	18-25	40-50
Service Port Cap	11-13	11-13	11-13	11-13	11-13

1. Valve Protection Cap-end
2. Refrigerant Valve Port (use Allen wrench to open/close)
3. Valve Protection Cap
4. Refrigerant Valve
5. Service Port Cap
6. Flare Nut
7. Unit Back Side
8. Copper Tube

When the outdoor unit is installed above the indoor unit an oil trap is required every 5m along the suction line at the lowest point of the riser. In case the indoor unit is installed above the outdoor, no trap is required.

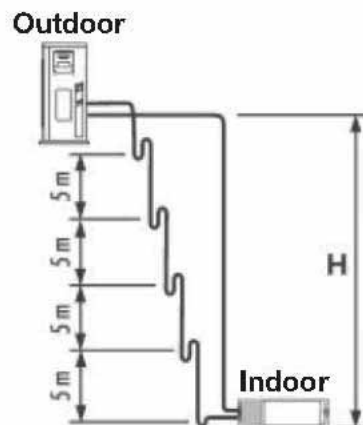

12. CONTROL SYSTEM

12.1 Electronic Control

12.1.1 Introduction

The electronic control information is designed for service applications, and is common to the following groups of air-conditioners:

- **ST/ RC group** -Cooling only / cooling and heating by heat pump.
- **SH group** -Cooling and heating by heat pump and supplementary heater.
- **RH group** -Cooling, heating by heaters only.

12.1.2 Jumpers Settings

GROUP	J6 Setting	J2 Setting
ST / RC	Open	Open
SH	Closed	Open
RH	Closed	Closed

12.2 Legend

AC	- Alternate Current
A/C	- Air-Conditioner
ANY	- ON or OFF status
CLOCK	- ON/OFF Operation Input, (dry contact)
COMP	- Compressor
CPU	- Central Processing Unit
ELUM	- Extended Louver Upward Movement (Software Jumper)
E ² PROM, EEP	- Erase Enable Programmable Read Only Memory
HE	- Heating Element
HPC	- High Pressure Control
H/W	- Hardware
ICP	- Indoor Condensation Pump
ICT	- Indoor Coil Temperature (RT2) sensor
IF, IFAN	- Indoor Fan
IR	- Infra Red
LEVEL1	- Normal Water Level
LEVEL2/3	- Medium/High Water Level
LEVEL4	- Overflow Level
Max	- Maximum
Min	- Minimum
min	- Minute (time)
NA	- Not Applicable
OCP	- Outdoor Condensation Pump
OCT	- Outdoor Coil Temperature (RT3) sensor
OF, OFAN	- Outdoor Fan
OPER	- Operate
Para.	- Paragraph
RAT	- Return Air Temperature (RT1) sensor
RC	- Reverse Cycle (Heat Pump)
R/C	- Remote Control
RCT	- Remote Control Temperature
RH	- Resistance Heater
RT	- Room Temperature (i.e. RCT in IFEEL mode, RAT otherwise)
RV	- Reversing Valve
SB, STBY	- Stand-By
sec	- Second (time)
Sect	- Section
SH	- Supplementary Heater
SPT	- Set Point Temperature
ST	- Standard (a Model with Cooling Only)
S/W	- Software
TEMP	- Temperature
W/O	- Without
WVL	- Water Valve
ΔT	- The difference between SPT and RT. in Heat Mode: $\Delta T = SPT - RT$ in Cool/Dry/Fan Mode: $\Delta T = RT - SPT$

12.3 General functions

12.3.1 COMP operation

For each Mode including POWER OFF & SB, a Min time delay of 3 min before COMP restarting, excluding DEICING Mode

The Min operation time of COMP under different operating conditions is

Operation Mode	Min operation time of COMP
Heat, Cool or Auto Modes	3 min.
Fan, Dry, Overflow, Protection modes, or mode change	ignored

12.3.2 IFAN operation

- Min time interval between IFAN speed change in AUTOFAN Mode, is 30 sec.
- Min time interval between IFAN speed change in H/M/L Mode is 1 sec.
- IFAN speed in Heat/Cool Autofan Mode is determined according to the following table:

ΔT	IFAN Speed
$\Delta T \geq 2$	HIGH
$2 \geq \Delta T \geq 1$	MED
$1 \geq \Delta T$	LOW

where in Heat Mode: $\Delta T = SPT - RT$
 in Cool Mode: $\Delta T = RT - SPT$

Note:

- In Heat Mode, the rules in section 4.0.3 have the higher priority.
- The table above can be represent by a hysteresis curve which will minimize the switching of the IFAN relay and will minimize the change in IFAN speed:

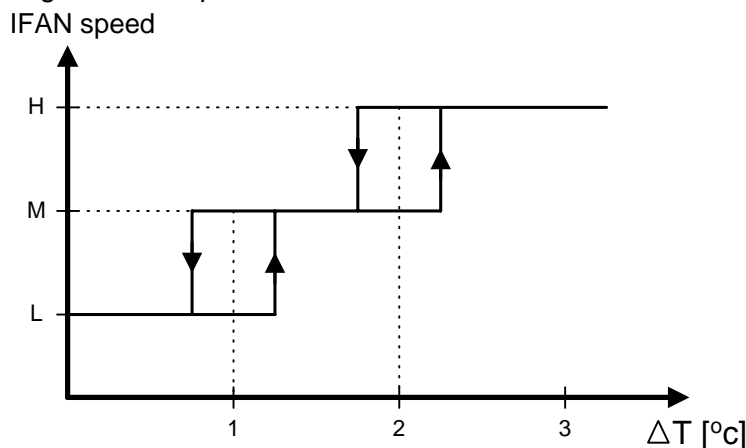

12.3.3 OFAN operation

- Min time interval between OFAN ON/OFF state change is 30 sec.
- In general, OFAN starts together with COMP.

12.3.4 HE operation

- Minimum Heaters ON or OFF time is 30 sec.
- Heaters can be activated only if IFAN is on.

12.3.5 Protections

- High pressure protection is applicable to all operating modes.
- Deicing control is valid in Heat and Auto Heat Mode only.
- Defrosting control is valid in Dry, Cool, Heat and Auto Modes.
- No reset after protection modes.

12.3.6 Thermistors operation

- Return air Temp. is detected by RAT (RT1) in normal Mode, or by RCT (R/C sensor) in I-FEEL Mode.
- Indoor Coil Temp. is detected by ICT (RT2).

12.3.6.1 Definition of thermistor faults:

- a. Thermistor is disconnected -
The thermistor reading is below -30°C .
- b. Thermistor is shorted -
The thermistor reading is over 75°C .
- c. Thermistor Temp reading doesn't change (irrelevant for RT1) -
 - (i) This test is performed only once after a unit is switched from OFF/STBY to operation. At the first occurrence of 10 min continuous COMP operation, the current ICT & OCT are compared with those when the COMP was switched from OFF to ON 10 min before. If the ΔT is less than 3°C , the thermistor is regarded as defective.
 - (ii) The ICT and OCT no-change error can be disabled together by connecting a 4.7 kohm resistor (5%) to the OCT connector. These resistors are equivalent to a thermistor at $43\pm 1^{\circ}\text{C}$ and $48\pm 1^{\circ}\text{C}$ respectively.
 - (iii) Connecting a 4.7 k resistor to the ICT connector will disable the ICT no-change error only.

12.3.6.2 Handling the thermistor faults in a COMP unit

- i. ICT/OCT thermistor is disconnected or shorted -
The invalid thermistor temperature is replaced by 43°C, so that the unit can continue the normal operation. All protections related to that faulty thermistor will be disabled. For example, in case of any ICT fault, the ICT high pressure protection in Heat Mode and ICT defrost protection in Cool Mode will not operate anymore. The same is also applied to the OCT fault.
- ii. RAT thermistor is disconnected or shorted –
The RAT will be derived from the ICT by using the equations :
- | | |
|------------|---------------|
| Heat Mode: | $RAT=ICT/2.3$ |
| Cool Mode | $RAT=ICT*4$ |

Notes:

- In case of any thermistor failure, the STBY LED will be blinking until the fault condition is corrected.
- User can use the system diagnostics function to find out the nature of the thermistor faults.

- i. RAT thermistor is disconnected or shorted –
System will operate continuously in the last IFAN & WVW status when turned ON.

Notes:

- As in the COMP unit, the STBY LED will be blinking to indicate a thermistor fault. And, the user can use the system diagnostics function to find out the nature of the fault.

12.4 Cooling Mode - General

- 1) Room Temperature, RT, is detected by
 - RAT in normal operation, or
 - RCT (R/C sensor) in I-FEEL mode.
- 2) The resolution of RT is 1°C.
 - RT is activating COMP/WVL if (RT > SPT), and
 - RT is stopping COMP/WVL if (RT ≤ SPT).
- 3) Indoor Coil Temp is detected by ICT (RT2).
- 4) Outdoor Coil Temp is detected by OCT (RT3).
- 5) OFAN OPERATIONS
 - OFAN starts together with COMP in general.

12.4.1 Cooling

Mode: Cool, Auto (at Cooling)
 Temp: Selected desired temperature.
 Fan: HIGH, MED, LOW
 Timer: Any
 I Feel: On or Off

Control function

Maintains room temp at desired level by comparing RT and SPT.

(RT - SPT) [°c]

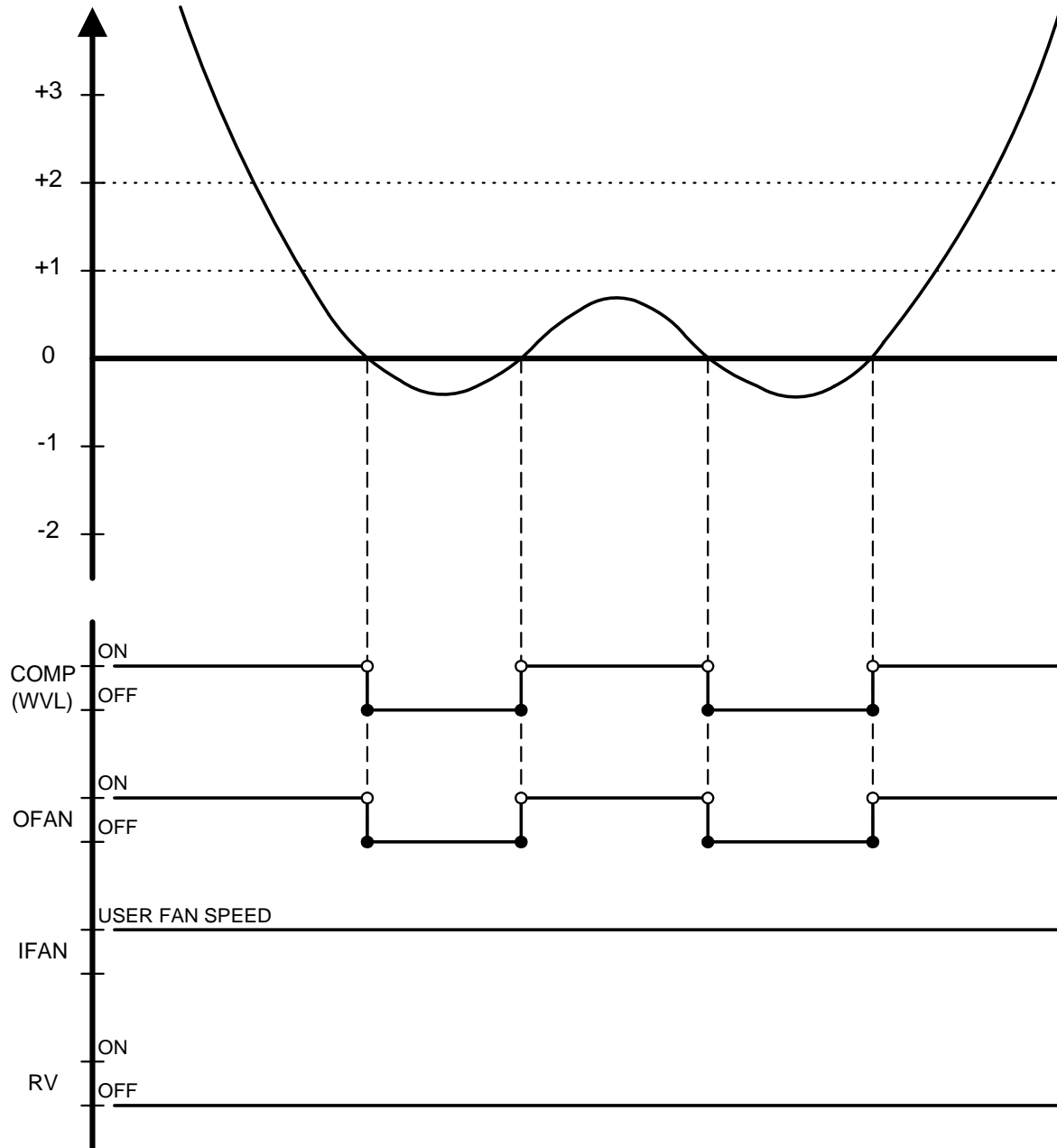

Note:

- 1) IFAN is always running at High, Medium or Low speed selected by user.
- 2) In IFEEL mode, the Room Temperature (RT) is the RCT from a R/C. Otherwise, the RT is the RAT from the Room Thermistor.

12.4.2 Cooling with Autofan

- Mode: Cool, Auto (at cooling)
- Temp: Selected desired temperature
- Fan: Auto
- Timer: Any
- I Feel: On or Off

Control function

Maintains room temp at desired level and controls the IFAN speed for optimal comfort.

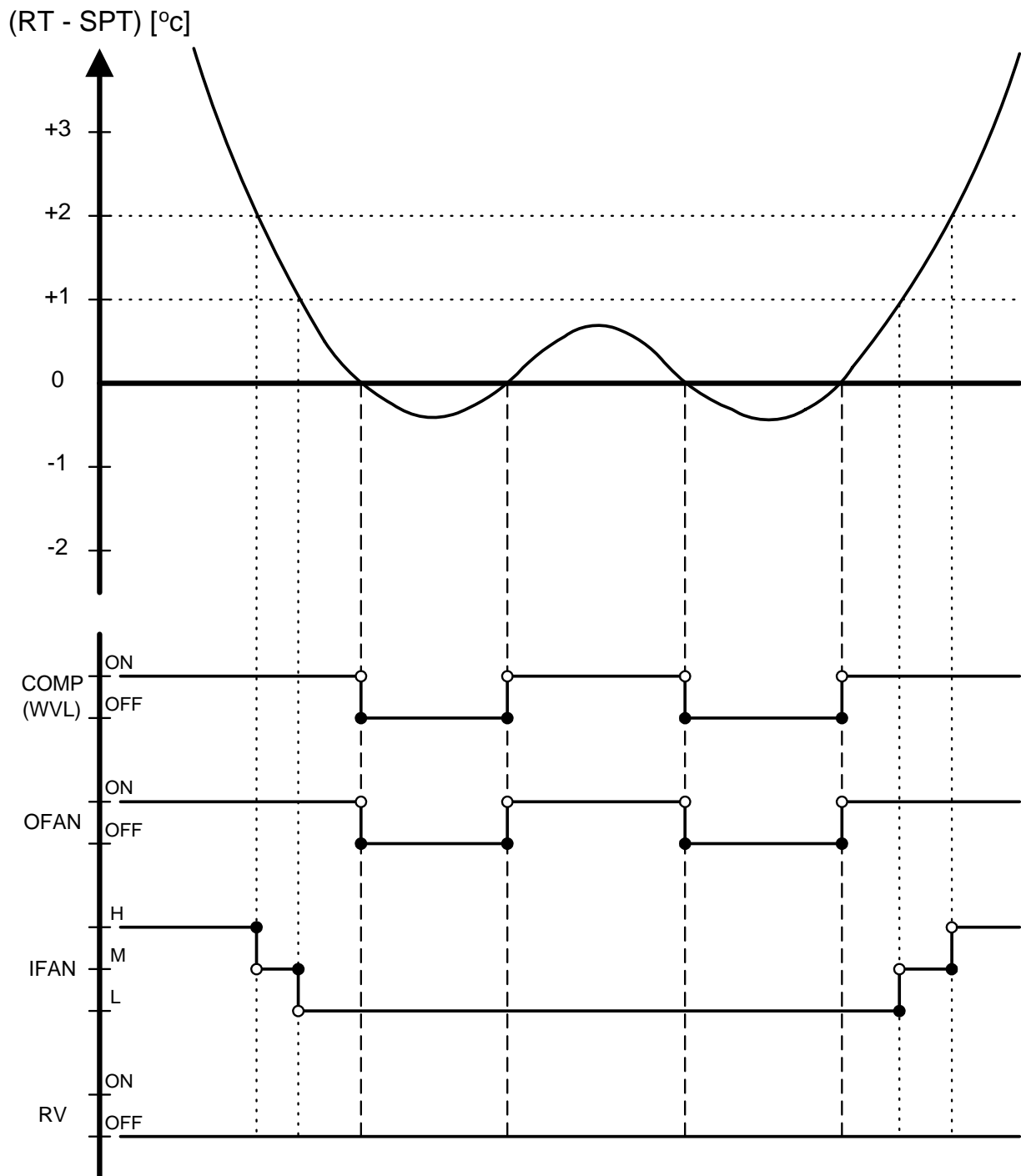

12.5 Heating Mode

12.5.1 Heating Mode - General

- In heating Mode, temp. compensation schedule will be activated for wall mounted units.

SPT [°C]	Add to SPT	
	I-FEEL ON	I-FEEL OFF
$18 \leq SPT \leq 27$	0 °C	+2 °C
$27 < SPT \leq 30$	0 °C	+3 °C

Notes :

- No compensation will be activated in Forced operation modes

12.5.2 IF operating rules

- As a general rule for **RC and SH groups**, when **COMP is ON**, excluding protection modes, IFAN will be switched ON if
- ICT > 35°C or
at the IFTC 30 sec after the COMP is switched ON. In this case, the IFAN will be started at low speed.

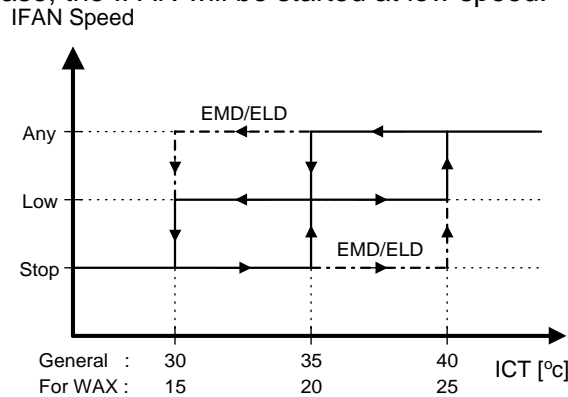

Notes :

- In **SH or RC group**, if HE is set to OFF due to low ICT, IFAN will be switched to LOW and will be turned OFF after 30 sec.
- An exception to this rule (4.0.3.a) is the Back-up mode for SH.
- In **RC and SH groups**, whenever **COMP & HE are both OFF**, excluding protection modes, IFAN operation will be according to the following:

In **other models** IFAN will operate in low speed for 30 sec and then stop. If COMP is OFF for more than 3 minutes and IFEEL Mode is inactive, IFAN will operate in low speed according to the following graph:

IFAN (Low Speed)

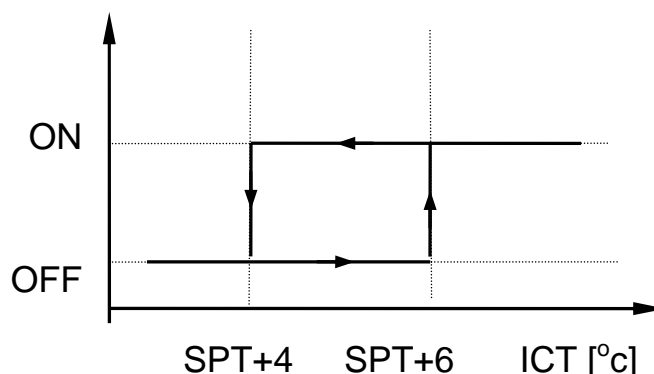

12.5.3 HE operation

- For **all Groups**, HE can be ON only when IFAN is ON.
- For **all Groups**, HE switches to OFF when $ICT > 50\text{ }^{\circ}\text{C}$, and is activated again when $ICT \leq 45\text{ }^{\circ}\text{C}$.
- In **SH or RC group**, HE operation is limited by the following graph:

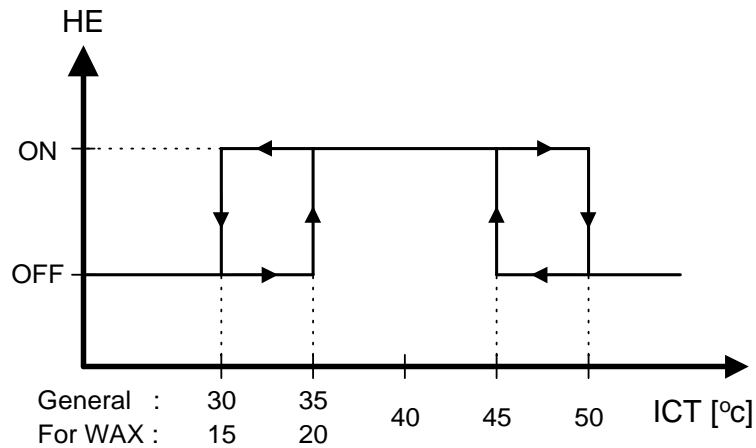

- Back-up mode for **SH group**

After COMP has been working for 5 minutes, HE & IFAN are activated even if the ICT is still below 35°C. This situation is called Back-up Mode. Both HE & IFAN will work in Back-up Mode until the ICT reaches 35°C. Then, the operation goes on in the usual mode .

12.5.4 Heating, RC or SH Group

Mode: Heat, Auto (at heating)
 Temp: Selected desired temperature
 Fan: HIGH, MED, LOW
 Timer: Any
 I Feel: On or Off

Control function

Maintains room temp. at desired level by comparing RAT or RCT to SPT.

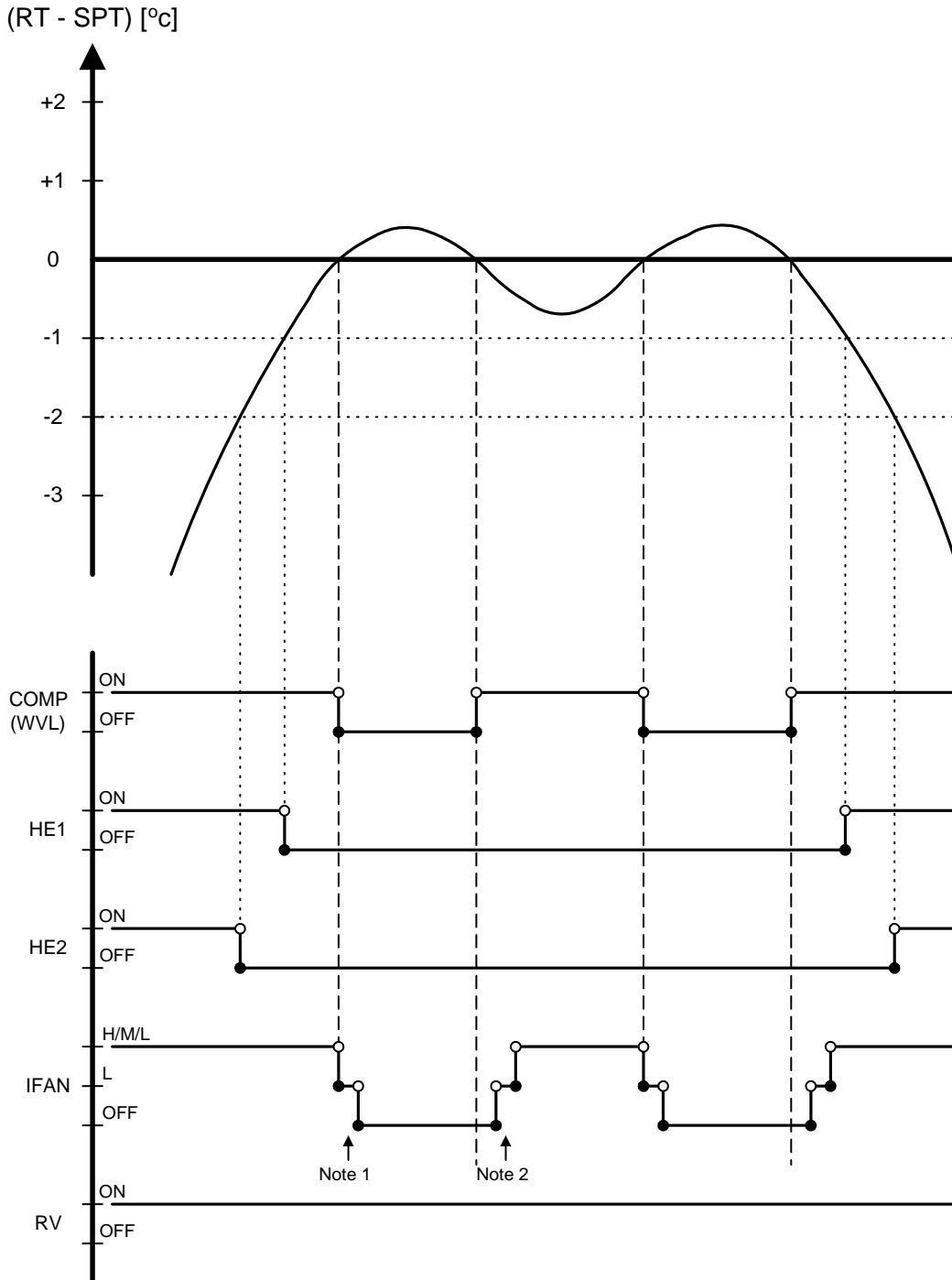

12.5.5 Heating, RC or SH Group with Autofan

Mode: Heat, Auto (at heating)
 Temp: Selected desired temperature
 Fan: Auto
 Timer: Any
 I Feel: On or Off

Control function

Maintains room temp at desired level by controlling COMP, IFAN and OFAN.

(RT - SPT) [°C]

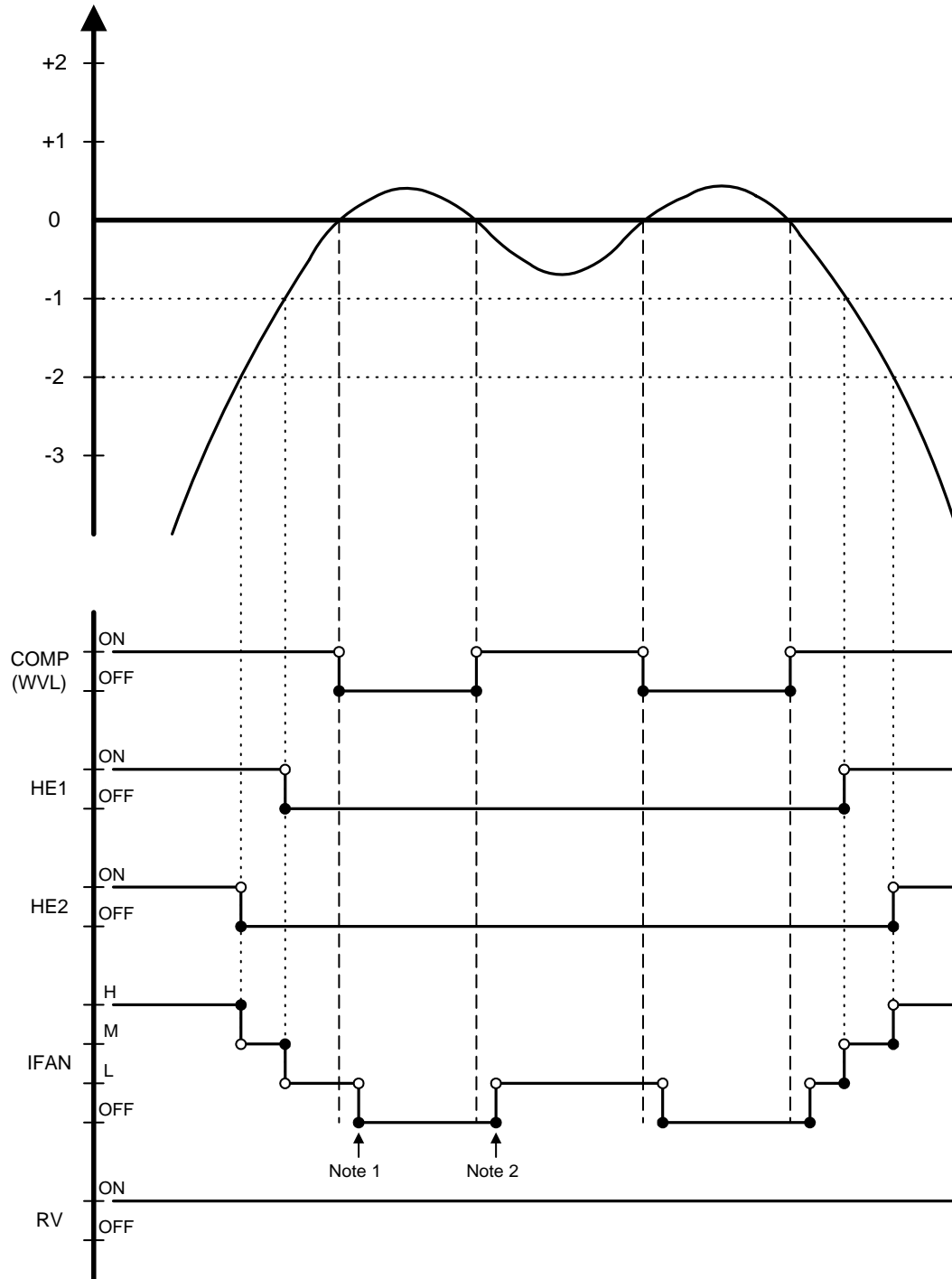

12.5.6 OFAN operation is controlled by the graph below when

1. (RAT \geq SPT - 2°C), AND
2. (ICT \geq 45°C), AND
3. (COMP is ON)

Otherwise, OFAN runs together with COMP.

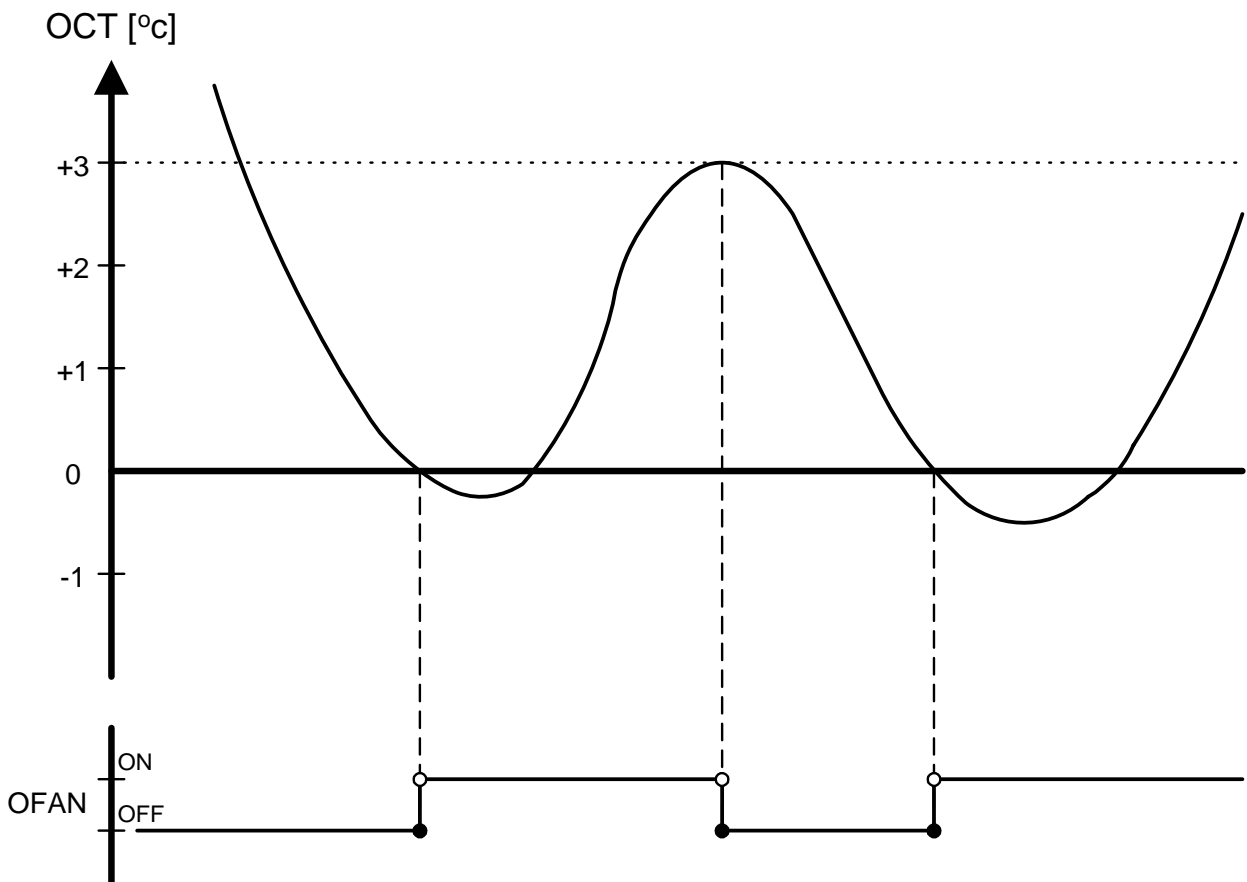

12.6 Automatic Cooling or Heating

12.6.1 Automatic Cooling or Heating - General

- Switching-temperature between Cooling and Heating is $SPT \pm 3^{\circ}\text{C}$.
- Autofan in Automatic Cooling and Heating Mode will activate “Cooling with Autofan Mode” and “Heating with Autofan Mode” respectively.
- When the Auto Mode is started with $SPT \pm 0^{\circ}\text{C}$, the unit will not select Auto Heat or Auto Cool mode immediately. Instead, the unit will be in a temporary Fan Mode with IFAN operating at low speed. The proper Auto Heat mode or Auto Cool will be started whenever the RT reaches $SPT-1^{\circ}\text{C}$ or $SPT+1^{\circ}\text{C}$ respectively.
- For RC & SH units, Mode change between Auto Heat & Auto Cool Modes is possible only after the COMP has been OFF during the last T minutes.

Mode Change	time, T
Auto Cool to Auto Heat	3 min
Auto Heat to Auto Cool	4 min

- When unit is changed from Cool/Dry mode to Auto Mode, the unit will continue to operate at (Auto) Cool Mode until the conditions for switching from Auto Cool to Auto Heat are satisfied. Similarly, when unit is changed from Heat Mode to Auto Mode, the unit will continue to operate at (Auto) Heat Mode until the conditions for switching from Auto Heat to Auto Cool are satisfied.

12.6.2 Auto Cooling or Heating, RC or SH Groups

- Mode: Auto
- Temp: Selected desired temperature
- Fan: Any
- Timer: Any
- I Feel: On or Off

Control function

Maintains room temp at desired level by selecting between cooling and heating modes.

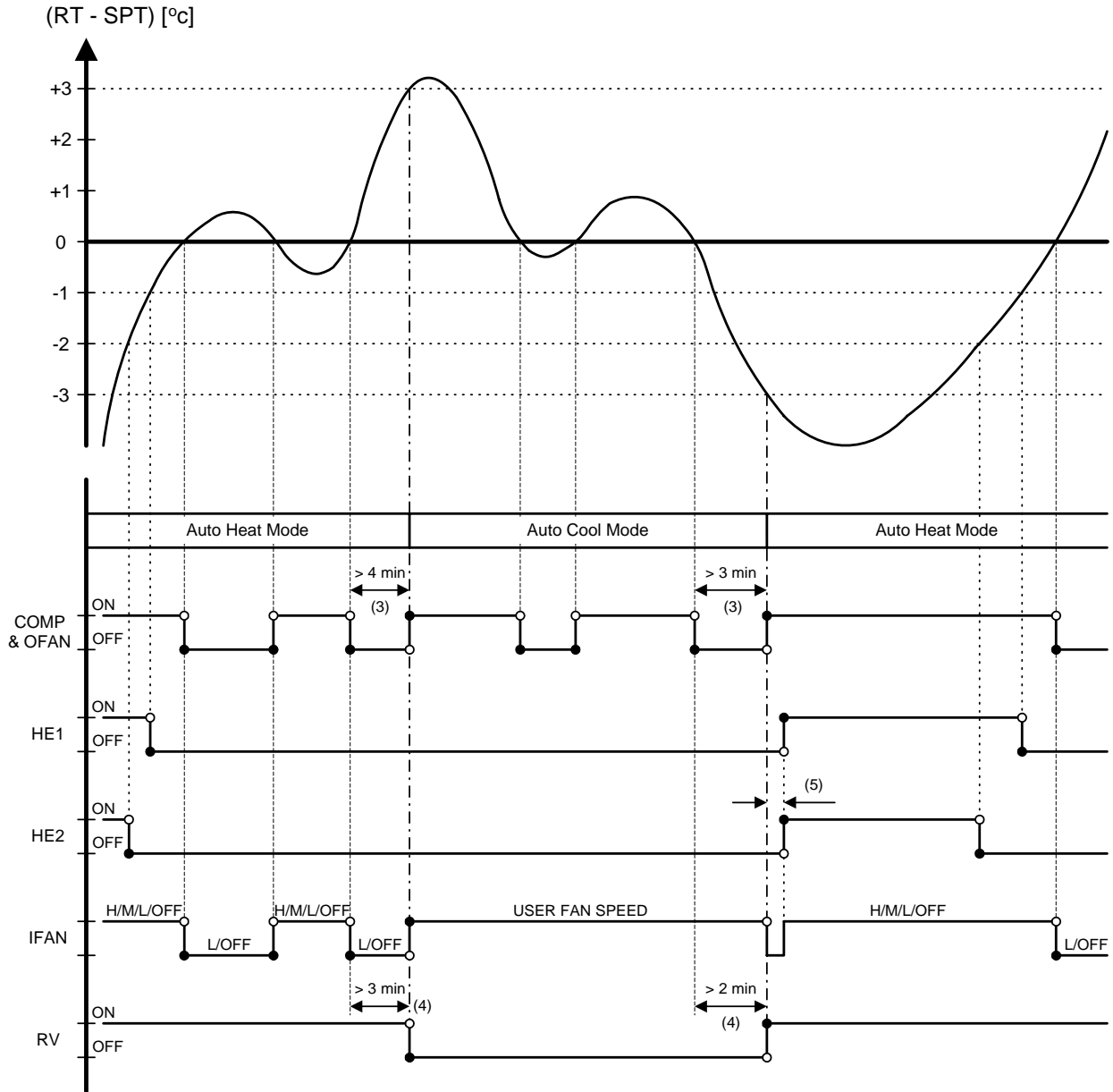

12.7 Dry Mode

12.7.1 Dry, ST or RC group

Mode: Dry
 Temp: Selected desired temp
 Fan: Low (automatically selected by software)
 Timer: Any
 I FEEL: Any

Control function

Reduce room humidity with minimum temp. fluctuations by operating in Cool Mode with low speed IFAN.

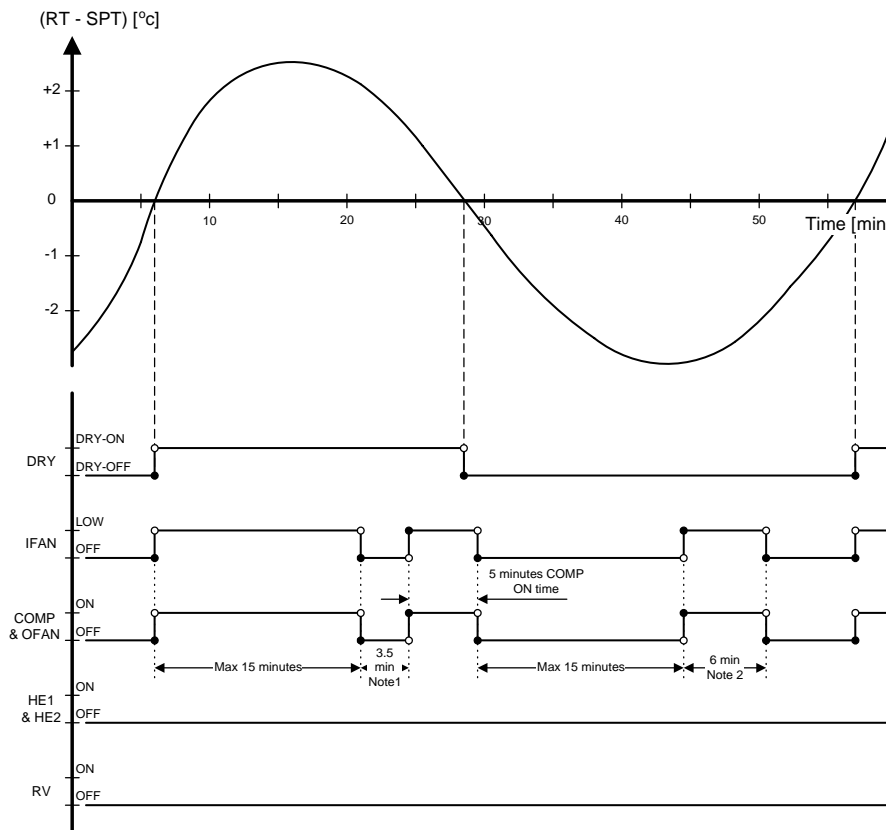

Notes :

- When Dry is ON, the COMP is forced OFF for 3.5 min (longer than the 3 min Min COMP-Off time) after every 15 min of continuous COMP operation.
- When Dry is OFF, the COMP is forced ON for 6 min (longer than the 3 min Min COMP-On time) after every 15 min of continuous COMP OFF time.
- When Dry is changed from ON to OFF or vice versa, the limits mentioned in (1) & (2) are ignored. The COMP operation is only controlled by the 3 min Min OFF time and 1 min Min ON time.
- In Dry Mode, IFAN is LOW when COMP is ON, and is OFF when COMP is OFF.

12.8 Protection

12.8.1 Cooling Mode Protections

Indoor Coil Defrost

Mode: Cooling, Dry, Auto
 Temp: Selected desired temp.
 Fan: Any
 Timer: Any
 I Feel: On or Off

Control Function

Protect the indoor coil from ice formation at low ambient temperature.

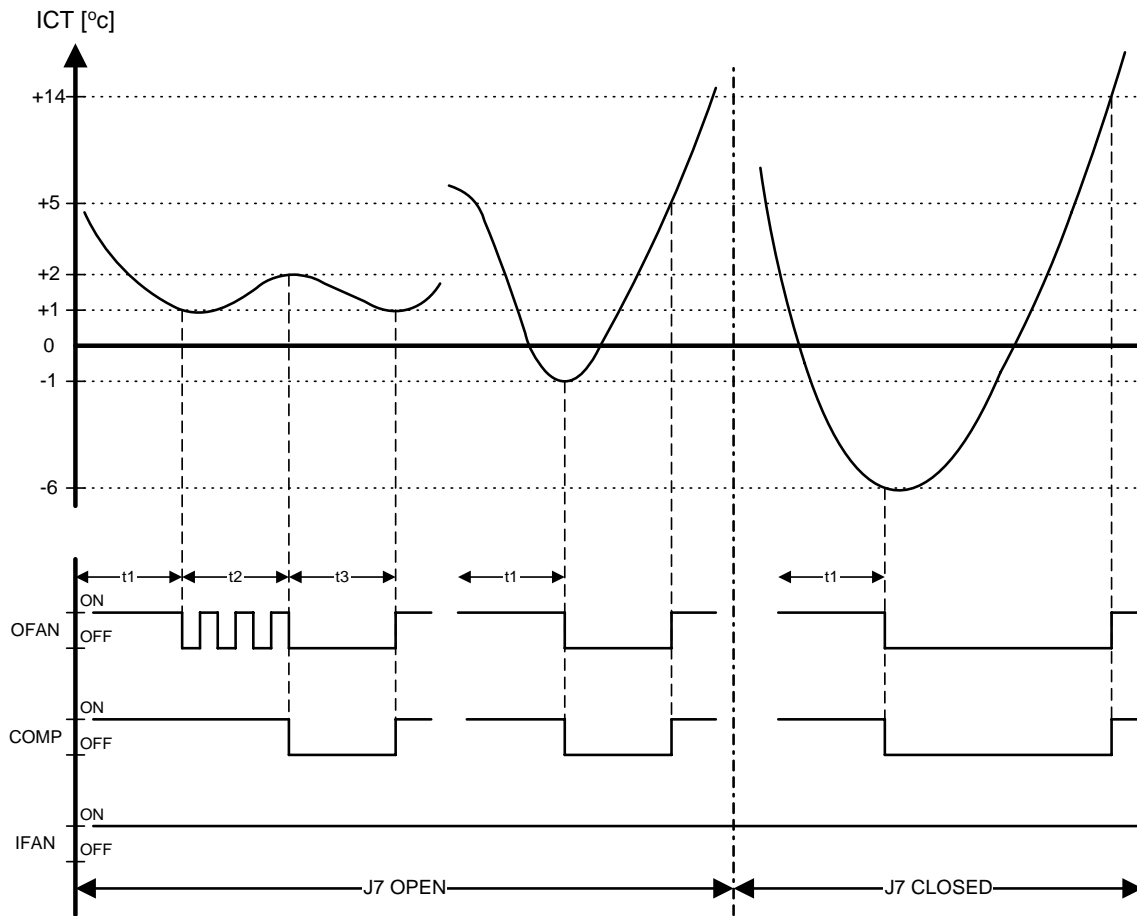

t1 = 5 min minimum for each COMP starting
 t2 = OFAN cycling (alternate between ON and OFF every 30 sec) for 20 min maximum
 t3 = COMP and OFAN stop for 10 min minimum

Notes:

- When J7 is closed (connected), OFAN cycling is cancelled and the set temperature for COMP & OFAN cut-out and cut-in are changed. COMP & OFAN are forced OFF when $ICT \leq -6^{\circ}C$, and are kept OFF until $ICT > 14^{\circ}C$.
- For WAX model, the defrost processes is simpler. When J7 is open, COMP & OFAN are forced OFF when $ICT \leq -1^{\circ}C$, and are kept OFF until $ICT > 5^{\circ}C$. When J7 is closed, the WAX defrosting process is the same as that of the other models (R.H.S. of the graph above). In both cases, the ICT checking in t2 and t3 are not applied.

12.8.2 High Pressure Protection

Mode: (Auto) Cooling or Dry
 Temp: Selected desired temp.
 Fan: Any
 Timer: Any
 I Feel: On or Off

Control Function

To protect the COMP from the high pressure built-up in the outdoor coil during normal cooling operation, by switching OFF the IFAN and COMP.

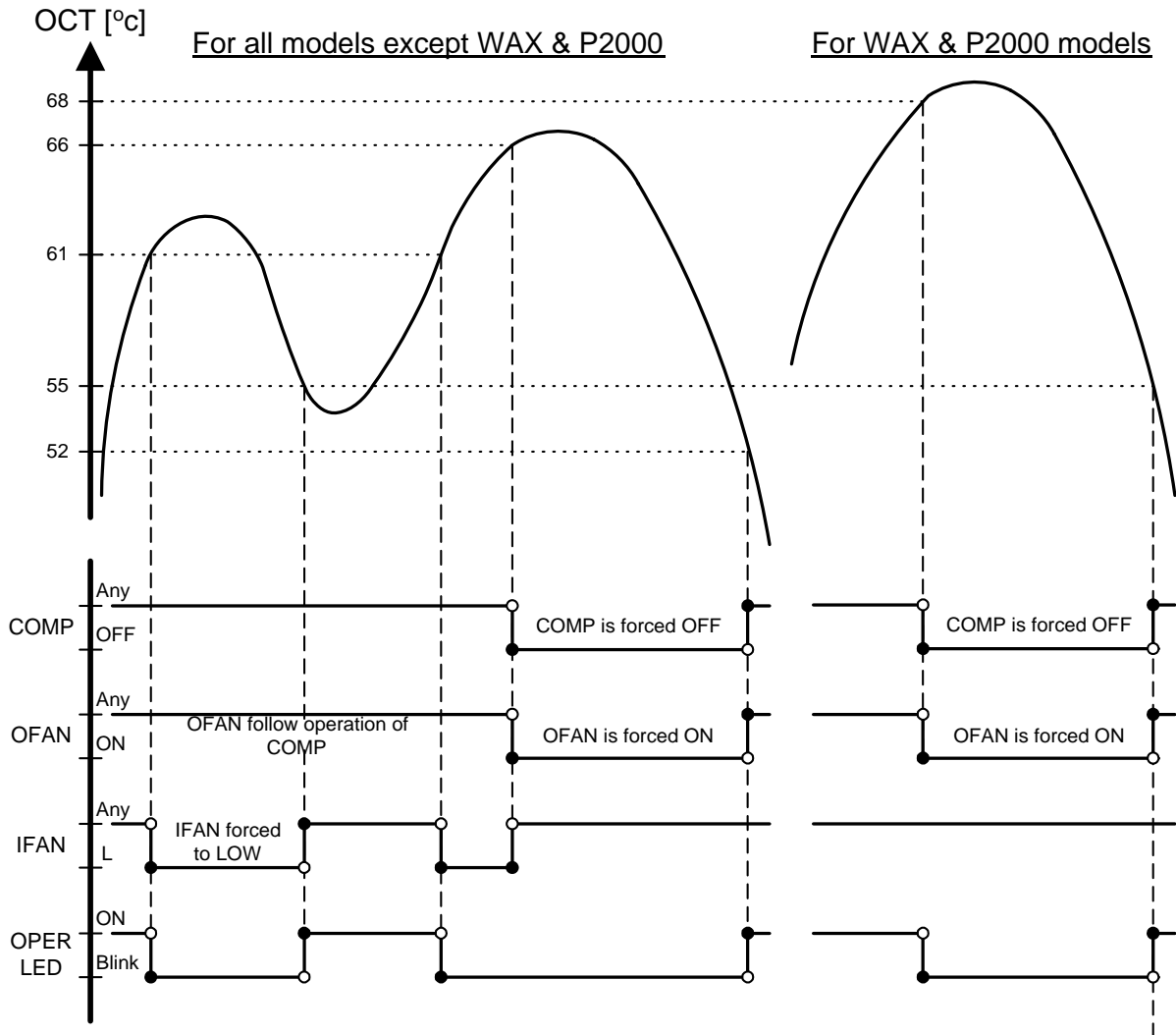

Note:

- The ICT is also monitored during Cool and Dry mode, in case the RV control circuit is faulty. Whenever ICT reaches 70°C, which indicates a high pressure in the indoor coil, the COMP will be forced off automatically. The COMP can be turned on again only after the ICT is under 70°C again and after the 3 min COMP ON delay time. The OPER LED will not blink in this case.

12.8.3 Heating Mode Protections

Outdoor coil Deicing (excluding RH Group)

Mode: Heating, Auto (at heating)

Temp: Selected desired Temp

Fan: Any

Timer: Any

I FEEL: Any

Control function

Protects the Outdoor coil from ice formation by controlling COMP & RV operation.

Scope

This new deicer is designed to operate at extreme temp conditions. The deicing cycle could be triggered from:

1. OCT temp and time between two consecutive deicing cycles.
2. Detection of ice forming by change of the OCT temp.

Both algorithms adjust the time between deicing cycles to optimize the A/C performance. The algorithm will automatically increase the time between deicing cycles and reduce the deicing cycle as needed.

The algorithm uses EEPROM data to operate.

Deicing procedure

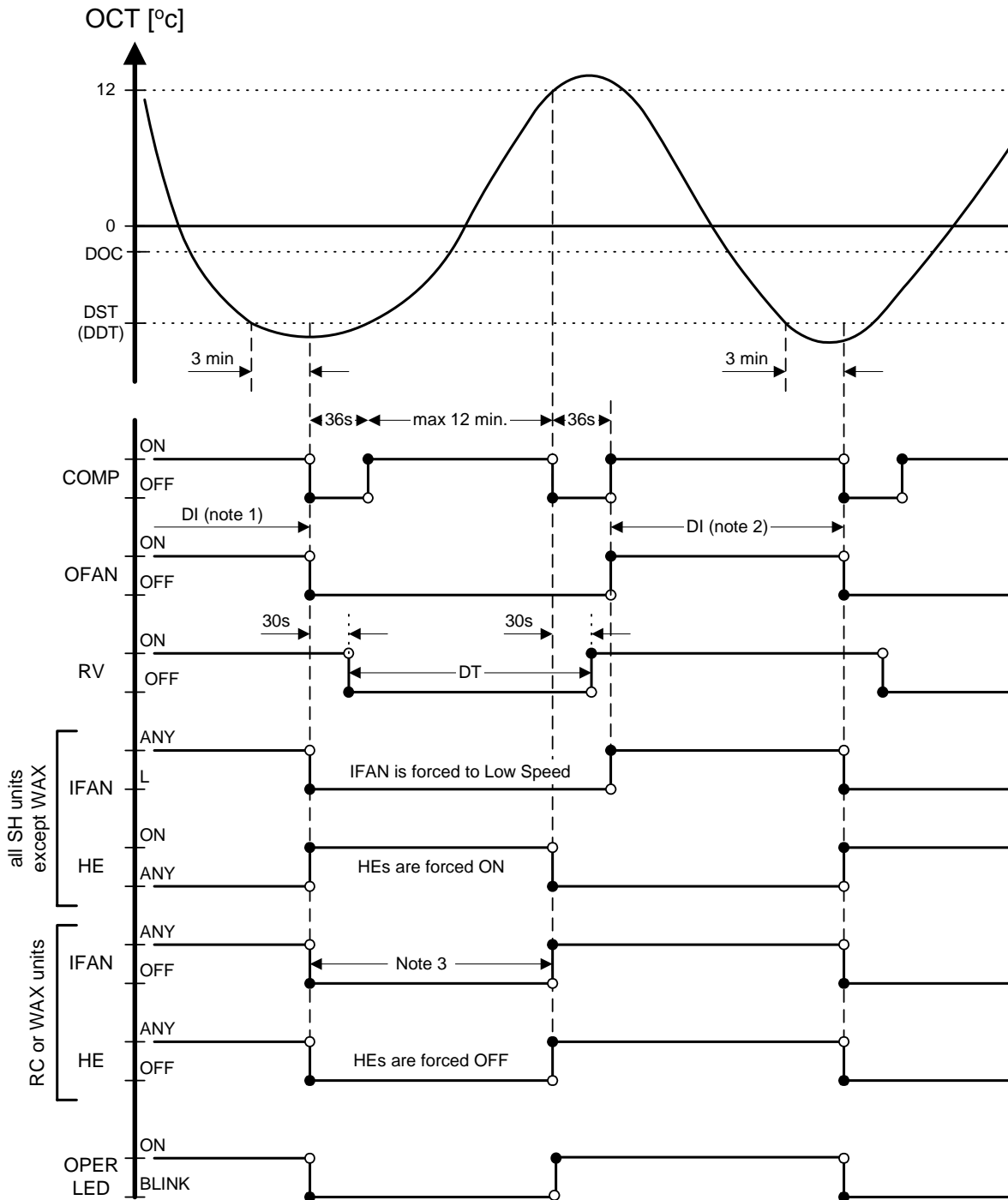

Notes :

- At the first COMP activation after SB or OFF, if (OCT < 0°C), then DI = 10 min, else DI = 40 min.
- In the following Deicing cycles, the time interval between two Deicing cycles activation is between 30 to 80 min (refer to the flow chart).
- For RC group, HEs are forced OFF. IFAN operation is as in Heat Mode, Sect 4.0.3.a, i.e. IFAN will be set to OFF when ICT < 30°C. For WAX, the IFAN is simply forced OFF.
- For SH group, HEs are forced ON and IFAN is forced to operate in Low speed, regardless of the ICT and difference between RAT & SPT.

12.8.4 High pressure protection (excluding RH Group)

Mode: (Auto) Heating
 Fan: Any
 Timer: Any
 I Feel: On or Off

Control Function

Protect the Compressor from high pressure by switching OFF the OFAN and COMP.

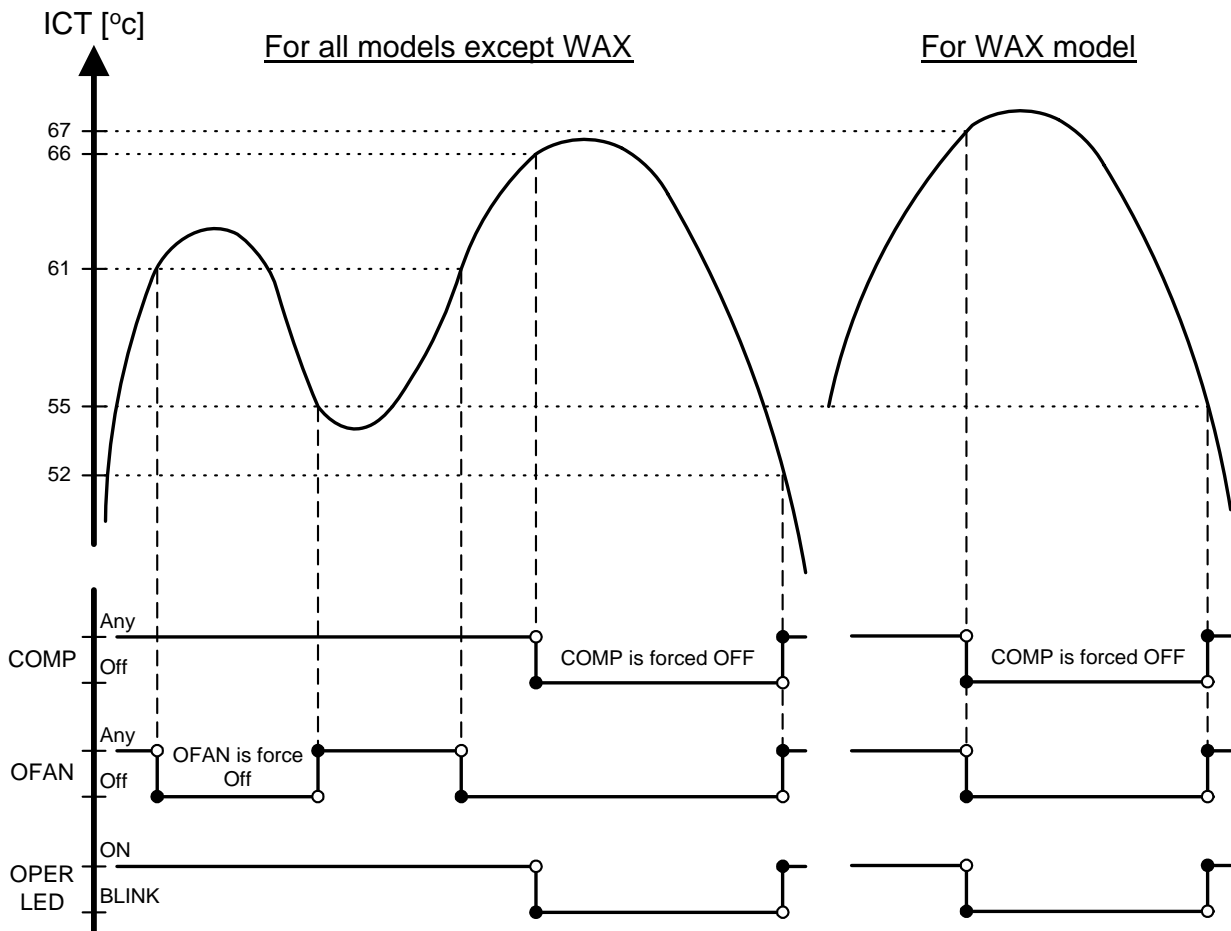

Notes:

- IFAN, HE1 and HE2 will be activated according to the relevant Heating Mode Sect.
- In case of any malfunction in the relay control circuit, the OCT is also monitored during heating mode. Whenever OCT reaches 70°C, which indicates a high pressure in the outdoor coil, the COMP will be forced off automatically. The COMP can be turned on again only after the 3 min COMP ON delay and the OCT is under 70°C. The OPER LED will not blink in this case.

12.9 Timer

Mode: Any
Temp. Selected desired temp
Fan: Any
Timer: Timer On, Timer Off
I Feel: On or Off

Control function

- Starts or stops the unit operation after pre-set time. If RC-1 is used, the timer setting will be (0.5 - 24 Hr) from the moment the timer is set. The minimum resolution is 30 minutes.
If RC-2 or later version of remote controls is used, the timer setting will be (0:00 - 23:50) real time with 10 minutes resolution.

- After power failure, all pre-set timers are cleared. The system is forced to STBY mode and the Timer LED indicator is blinked to indicate the situation. The LED keeps blinking until the timer settings can be reloaded from a R/C message.

Note: If all timers are inactive, the system will not be forced OFF after the power failure. The last OPER/STBY status will be loaded from the EEP instead.

- When the A/C receives any valid message from a R/C, the current ON/OFF timer settings will be replaced by the new timer settings in the R/C message.

Note: The following timer related operations will not affect the A/C operating mode (Heat/Cool/Auto/Dry/Fan) setting.

- Set ON/OFF timer
- Clear ON/OFF timer
- R/C ON Timer is time-up
- R/C OFF Timer is time-up

E.g. When a STBY A/C unit (with Cool Mode setting in its EEP) is turned on by the ON-TIMER of a R/C with heat mode setting, the A/C will start in Cool Mode.

12.10 Forced Operation

Forced operation allows units to start, stop and operate in Cooling or Heating in pre-set temperature according to the following table:

Forced operation mode	Pre-set Temp for : WMZ, WMF,WNG models
Cooling	22°C
Heating	28°C

Note:

- While under the forced operation, the temperature compensation schedule.
- The forced operation is activated when the mode button on the Display Board is used to switch the unit to Cool or Heat mode.
- The IFAN is always set to Autofan Speed in forced operation.

12.11 Sleep Mode

- Mode: Any
- Temp: Set – desired temperature selected
- Fan: Any
- Timer: Interact with Sleep Timer as described in sect 12.2
- I Feel: On or Off

The Sleep mode is activated by using the sleep button on the R/C. In Sleep Mode, the unit will automatically adjust the SPT to turn up/down the room temperature (RT) gradually to provide maximum comfort to the user in sleep.

Sleep is treated as TIMER function. Therefore, the TIMER LED is activated similar to TIMER function.

12.11.1 Adjustment in Sleep Mode

1. in cool, auto cool or dry modes, the SPT adjustment is positive (from 0 to +3°C).
2. In heat or auto heat modes, the SPT adjustment is negative (from 0 to -3°C).
3. In other modes, there is no SPT adjustment.
4. The SPT adjustment is cancelled when the Sleep mode is cancelled.

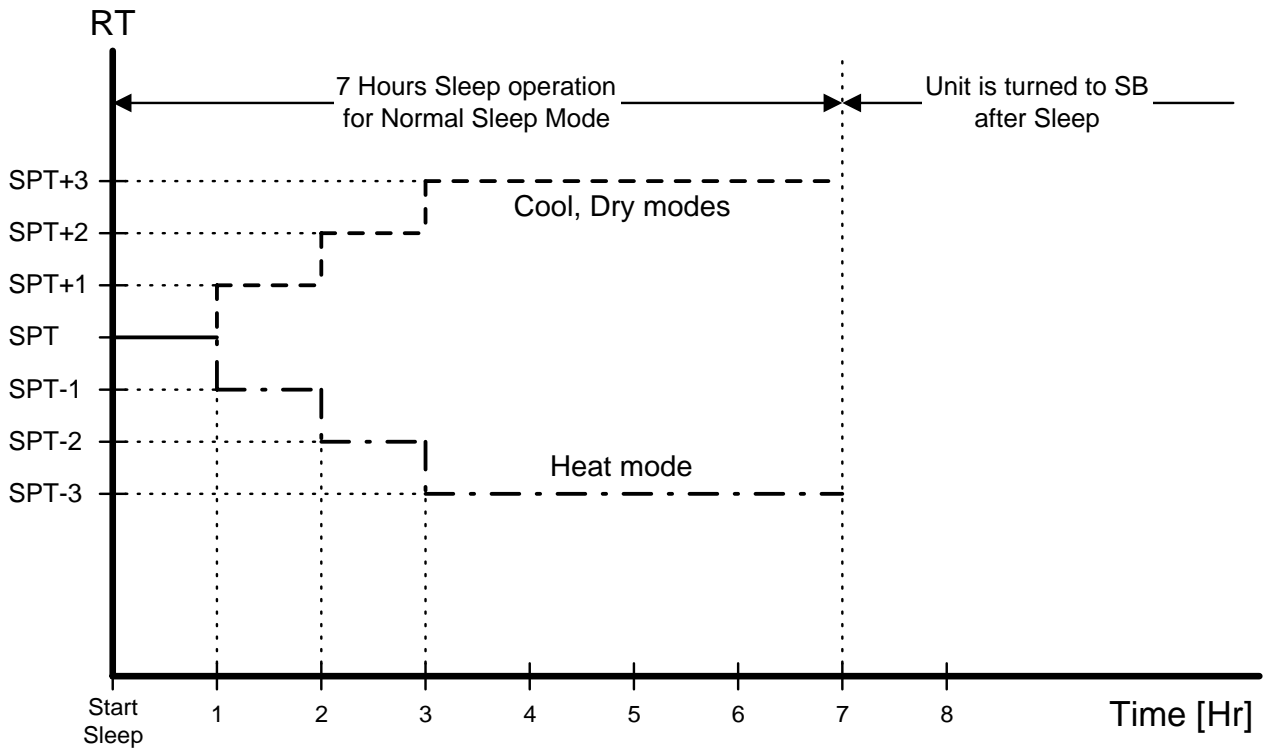

Note: If Off-timer is active, the unit may go to SB before or after 7 hours of sleep operation.

12.11.2 Time adjustment in Sleep Mode

The user can make use of the Off-Timer to extend the Sleep Time from 7 hours to 12 hour (max). The operation of the new “Extended Sleep Mode” is illustrated by the graphs below.

Case 1 is the Standard Sleep Mode, which is the only sleep mode in previous version of MCU. The A/C unit simply works for 7 hours, then goes to SB.

Case 2 is the new Extended Sleep Mode. If an active Off-Timer is set to turn off the A/C between 7-12 hour, relative to the starting of Sleep, the Sleep time is extended.

And, instead of going to SB at the 7th hour, the A/C will work until reaching the Off-time.

Case 3 is an exception to case 2. The Sleep Mode will not be extended to the Off-Time when the Off-Timer is preceded by an On-Timer, which is also between 7-12 hour.

Case 1 : Standard Sleep Mode

Condition : Off-timer is not set or is beyond 12 hour.

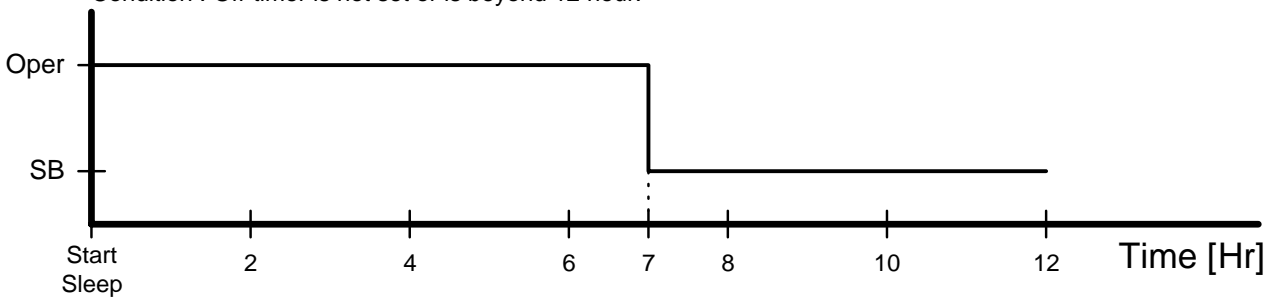

Case 2 : Extended Sleep Mode

Condition : Off-timer is set at 7-12 hour.

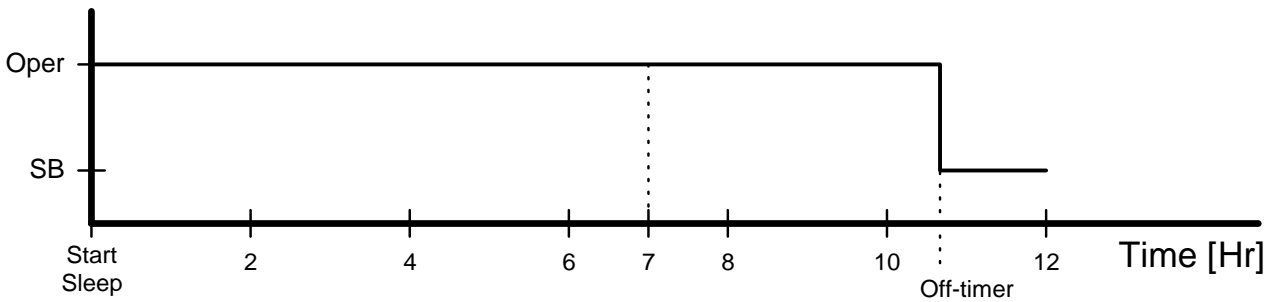

Case 3 : Exception to Case 2

Condition : Off-timer is set at 7-12 hour

On-timer is set at 7-12 hour and before Off-timer

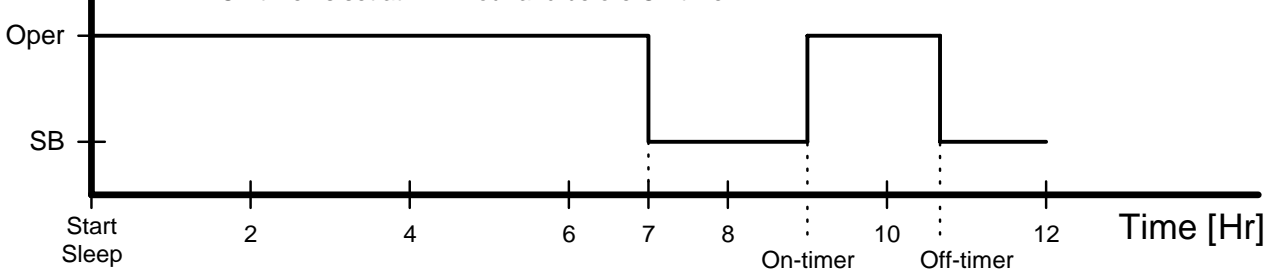

12.12 Controller Self-Test Procedure

12.12.1 By Shorting Test Jumper J1

SELF-TEST FLOW CHART
FOR CONTROLLER (VERSION 4V5 OR HIGHER)

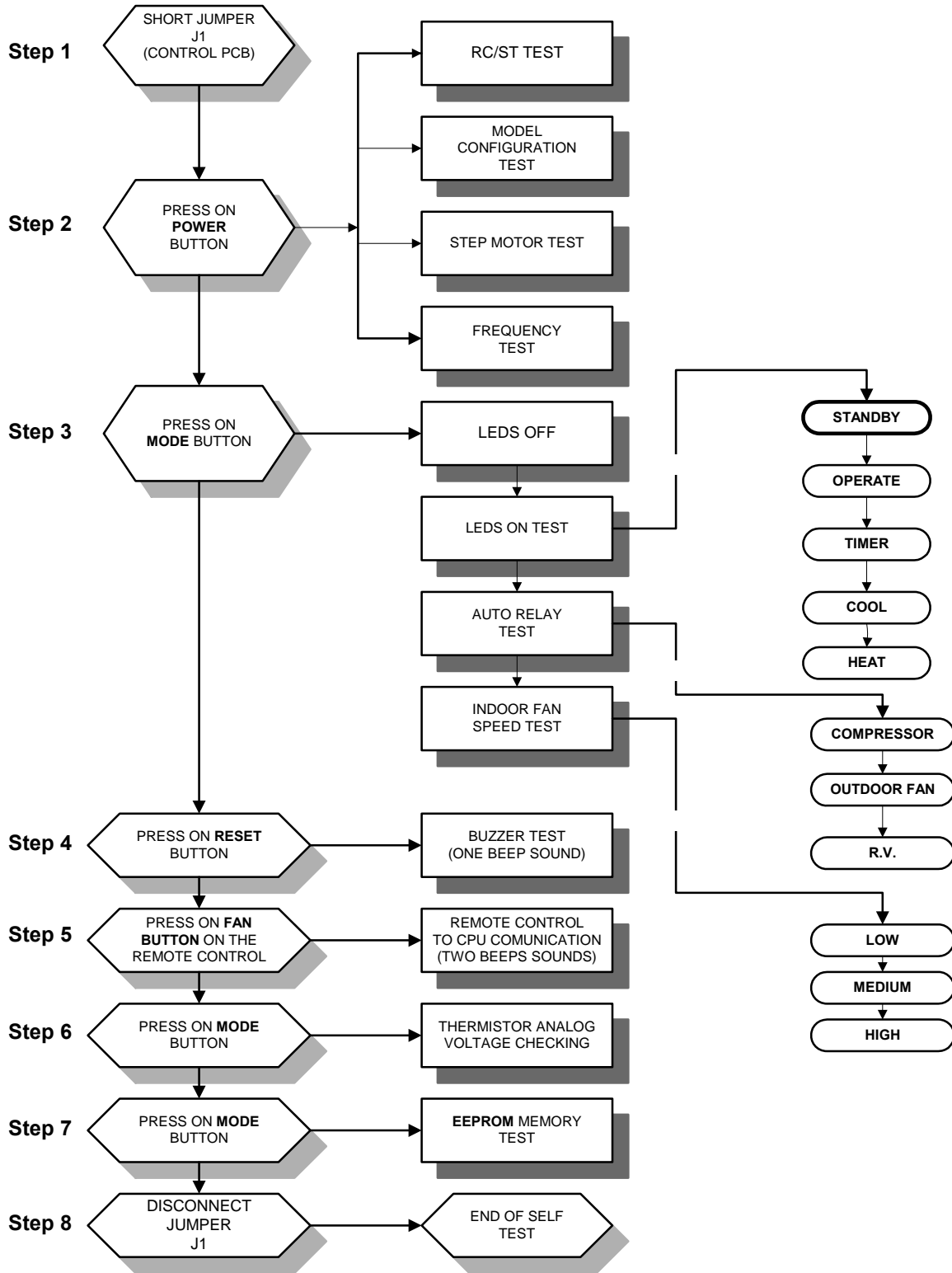

12.12.2 By Remote Control Settings:

- a. 1: TURNING ON THE POWER.
Turn ON the power, make sure that the unit is in operation.
- b. STEP 2 : ENABLE SELF-TEST MODE
 - Use the remote control to send the first settings to display / indoor unit HEAT mode, HIGH IFAN, set temperature to 16 °C, no I-FEEL Sleep or any other timer settings are needed.
 - Cover the IR transmitter components in the remote control so that it will not transmit the signals to the indoor unit display.
 - Use the remote control to send the second settings to display / indoor unit COOL mode, LOW IFAN, no I-FEEL Sleep or any other timer settings.
 - Uncover the remote control IR transmitter and change the temperature settings. If the display/indoor unit receive the settings properly the following steps will start:
- c. STEP 3: MODEL SETTING CONFIRMATION
 - The STAND-BY and COOL LEDS will indicate the operation mode as follows:

OPERATION MODE	STAND-BY LED	COOL LED
ST	ON	OFF
RC	OFF	OFF
SH	OFF	ON
RH	ON	ON

- Testing the Model configuration. Selected by the COMP, STAND-BY, TIMER LEDS and FILTER will indicate the model configuration as follows (the relevant line for this manual is highlighted):

MODEL	COMP	OPERATE LED	TIMER LED	FILTER LED
WNG	ON	OFF	OFF	OFF
WMZ	ON	ON	OFF	ON
WMN4	OFF	OFF	ON	OFF
WMN2/WHX	OFF	ON	OFF	ON
WMN3	OFF	ON	ON	ON

In this term the step motor will turn to HOME POSITION.

d. STEP 4 : AUTO LED WALK TEST.

- All the LEDS will turn OFF.
- All the LEDS will turn ON for 1 second one by one in the following sequence:
 STAND-BY ⇨ OPERATE ⇨ TIMER ⇨ FILTER ⇨ COOL ⇨ HEAT.
- In PRX all the LEDS will turn ON for 1 second one by one in the following sequence : 18 °c ⇨ 20 °c ⇨ 22 °c ⇨ 24 °c ⇨ 26 °c ⇨ 28 °c ⇨ 30 °c ⇨ High IFAN ⇨ Auto IFAN ⇨ Med IFAN ⇨ Low IFAN ⇨ STAND-BY⇨ TIMER ⇨ FILTER ⇨COOL⇨ HEAT.

e. STEP 5: AUTO REALY WALK TEST:

- All relays will energize one by one in the following sequence:
 COMPRESSOR ⇨ OUTDOOR FAN⇨R. V. ⇨ HEATER 1 ⇨ HEATER 2
 ⇨ INDOOR WATER PUMP ⇨ SWING or OUTDOOR WATER PUMP ⇨
 INDOOR FAN: LOW ⇨ MID ⇨ HIGH.
- When the relay walk test is completed, the next test will start automatically.

f. STEP 6: FREQUENCY TESTING:

- If the frequency measuring process fails the COOL LED will turn ON. In order to move to the next step, press ON/OFF button on the remote control.

g. STEP 7: INPUT TEST.

- The test purpose is to check the analog real time indicators (thermistors, LEVEL and clock) according to the table below.

LED Indicator	Condition for LED to be ON
STBY LED	Room thermistor ≠ 25°C
OPER LED	Indoor coil thermistor ≠ 25°C
TIMER LED	Outdoor coil thermistor ≠ 25°C
FILTER LED	Clock
COOL LED	LEVEL 2&3
HEAT LED	LEVEL 4

h. STEP 8: TIMING RESET TEST (WATCH DOG).

- The test purpose is to verify that the CPU rise time after power failure is between 1 to 3 sec, test results are indicated on the LEDS : STAND-BY,OPER, TIMER and FILTER turning ON one by one.
- The results of the test are coded as follows:
 Pass condition:
 1 sec - STAND-BY and OPER are turned ON
 2 sec - STAND-BY, OPER and TIMER are turned ON

Fail condition:

0 sec - STAND-BY is turned ON

3 sec - STAND-BY, OPER, TIMER and FILTER are turned ON

- When the timing reset test is completed, the next test will start automatically.

i. **STEP 9: MEMORY TEST (EEPROM)**

- The test purpose is to check if the memory is functioning correctly. The test result is reported by using the STAND-BY and FILTER LEDS:

LED Indicator	Condition for LED to be ON
STAND-BY LED	Test passed
FILTER LED	Test failed

AT THIS POINT THE SELF-TEST IS COMPLETED.

In order to terminate Self-Test mode the User can change the unit setting from COOL Mode, LOW FAN to COOL Mode, MED FAN or to wait without using the remote control for 60 sec.

Values of Sensors Temperature VS. Voltage (DC)

Temp. (*C)	Voltage (V)	Temp. (*C)	Voltage (V)	Temp. (*C)	Voltage (V)	Temp. (*C)	Voltage (V)
-20	4.554	2	3.744	24	2.555	46	1.487
-19	4.529	3	3.695	25	2.5	47	1.447
-18	4.502	4	3.646	26	2.445	48	1.409
-17	4.475	5	3.595	27	2.391	49	1.371
-16	4.446	6	3.544	28	2.338	50	1.334
-15	4.417	7	3.492	29	2.284	51	1.298
-14	4.386	8	3.439	30	2.232	52	1.263
-13	4.354	9	3.386	31	2.18	53	1.228
-12	4.322	10	3.332	32	2.128	54	1.195
-11	4.287	11	3.278	33	2.077	55	1.162
-10	4.252	12	3.223	34	2.027	56	1.13
9	4.216	13	3.168	35	1.978	57	1.099
-8	4.178	14	3.113	36	1.929	58	1.069
-7	4.14	15	3.058	37	1.881	59	1.04
-6	4.1	16	3.002	38	1.834	60	1.011
-5	4.059	17	2.946	39	1.798	61	0.983
-4	4.017	18	2.89	40	1.742	62	0.956
-3	3.974	19	2.833	41	1.698	63	0.929
-2	3.93	20	2.777	42	1.654	64	0.904
-1	3.885	21	2.722	43	1.611	65	0.879
0	3.839	22	2.666	44	1.569	66	0.854
1	3.792	23	2.61	45	1.527	67	0.831

12.13 On Unit Indicators and Controls

<p>STAND BY INDICATOR</p>	<p>Lights up when the Air Conditioner is connected to power and ready to receive the R/C commands Blinks continuously in case of any thermistor failure.</p>
<p>OPERATION INDICATOR</p>	<p>Lights up during operation. Blinks for 300 ms, to announce that a R/C infrared signal has been received and stored. Blinks continuously during</p> <ul style="list-style-type: none"> • OCT High Pressure Protection Mode • ICT High Pressure Protection Mode • Deicing in Heating Mode • Water Over Flow in ECC Model
<p>MODE BUTTON (Cool, Heat, SB)</p>	<p>Use to cycle the operation mode of the A/C unit among COOL, HEAT and SB modes, without using the R/C. Every time this switch is pressed, the next operation mode is selected, in this order : SB → Cool Mode → Heat Mode → SB → ... Press this button continuously for 5 sec or more to start the Diagnostic Mode.</p>

12.14 Clock Random Delay From 0 to 2.5 seconds

- 0 = Clock Switch Open
- 1 = Clock Switch close

The Clock is activate according to the following table:

A/C STATE (before clock is changed)	CLOCK STATE (before clock is changed)	CLOCK ACTION (clock is changed)	A/C NEW STATE (after clock is changed)
ON	1	0	OFF
OFF	0	1	ON
OFF by interrupt ⁽¹⁾	1	0	OFF
ON by interrupt ⁽¹⁾	0	1	ON

Notes :

1. Clock can be interrupted by :
 - R/C - POWER ON/OFF Push-button.
 - R/C - TIMER.
 - R/C - SLEEP.
 - A/C - MODE SWITCH.
2. Any change in the CLOCK level during the first 6 sec after the system Reset is ignored.

13. TROUBLESHOOTING

NO	SYMPTON	PROBABLE CAUSE	CORRECTIVE ACTION
1.	The stand-by indicator (red led) on the central control display panel doesn't light up.	There is no correct voltage between the line and neutral terminals on main P.C.B	-If the voltage is low repair power supply. -If there is no voltage repair general wiring. -If there is correct voltage replace main or display P.C.B'S
2.	The operation indicator (green led) on the central control display panel does not light up.	The remote control batteries are discharged	-Replace batteries of the remote control.
3.	The operation indicator (green led) does not light up when starting from unit.	Check main P.C.B and display P.C.B	-Replace P.C.B if necessary.
4.	The indoor fan does not function correctly.	Check the voltage between indoor fan terminals on the main P.C.B	-If there is voltage replace capacitor or motor.
5.	The outdoor fan does not function correctly.	Check the voltage between outdoor fan terminals on the main P.C.B There is voltage between outdoor fan terminals on the outdoor unit. There is no voltage between outdoor fan terminals on the outdoor unit.	-If there is no voltage replace main P.C.B -Replace capacitor or motor. -Check and repair electrical wiring between indoor and outdoor units.
6.	The compressor does not start up.	Check voltage on compressor terminals on the outdoor unit. (with ammeter) Check if there is correct voltage between compressor terminals on the outdoor unit.	-If no voltage replace main P.C.B -If low voltage repair power supply. -If the voltage correct replace capacitor or compressor. -If there is no voltage repair electrical wiring between indoor and outdoor units.
7.	The refrigeration system does not function correctly.	Check for leaks or restrictions. With ammeter. Pressure gauge or surface thermometer.	-Repair refrigeration system and charge refrigerant if necessary.

NO	SYMPTON	PROBABLE CAUSE	CORRECTIVE ACTION
8	No cooling or heating only indoor fan works.	Outdoor fan motor faulty or other fault caused, compressor overload protection cut out.	-Replace P.C.B. -Outdoor fan blocked remove obstructions.
9.	Only indoor fan and compressor working.	Outdoor fan blocked.	-Remove obstructions.
10.	Only indoor fan working.	-Run capacitor of outdoor fan motor faulty. -Windings of outdoor fan are shorted.	-Replace capacitor. -Replace motor.
11.	No cooling or heating takes place, indoor fans working.	-Overload safety device on compressor is cut out (low voltage or high temperature). -Compressor runs capacitor faulty. -Compressor windings are shorted.	-Check for proper voltage, switch off power and try again after one hour. -Replace compressor capacitor. -Replace compressor.
12.	No air supply at indoor unit, compressor operates.	-Indoor fan motor is blocked or turns slowly. -Indoor fan run capacitor faulty. -Motor windings are shorted.	-Check voltage, repair wiring if necessary. -Check fan wheel if it is tight enough on motor shaft, tighten if necessary.
13.	Partial, limited air supply at indoor unit.	Lack of refrigerant (will accompanied by whistling noise) cause ice formation on indoor unit coil in cooling mode.	-charge the unit after localizing leak.
14.	Water accumulates and over flow from indoor unit section.	Drain tube or spout of drain pan clogged.	-Disassemble plastic drain tube from spout of indoor unit drain pan.
15.	Water dripping from outdoor unit base, (in heating mode).	Water drain outlet is clogged.	-Open outdoor unit cover clean out water outlet clean the base inside thoroughly.
16.	Freeze-up of outdoor coil in heating mode, poor heating effect in room, indoor fan operates.	-Faulty outdoor thermistor. -Faulty control cable. -Outdoor temperature is below design conditions. -Outdoor unit air outlet is blocked.	-Replace thermistor. -Repair control cable. -Shut unit off, it cannot work properly. -Remove obstructions.
17.	Unit is in heat mode but operating in cooling.	-Faulty RV coil. -RV coil is ok valve is stuck position.	-Replace RV coil. -Replace the reversing valve.

14. EXPLODED VIEWS AND SPARE PARTS LISTS

14.1 Indoor Unit Alpha 7, 9, 12

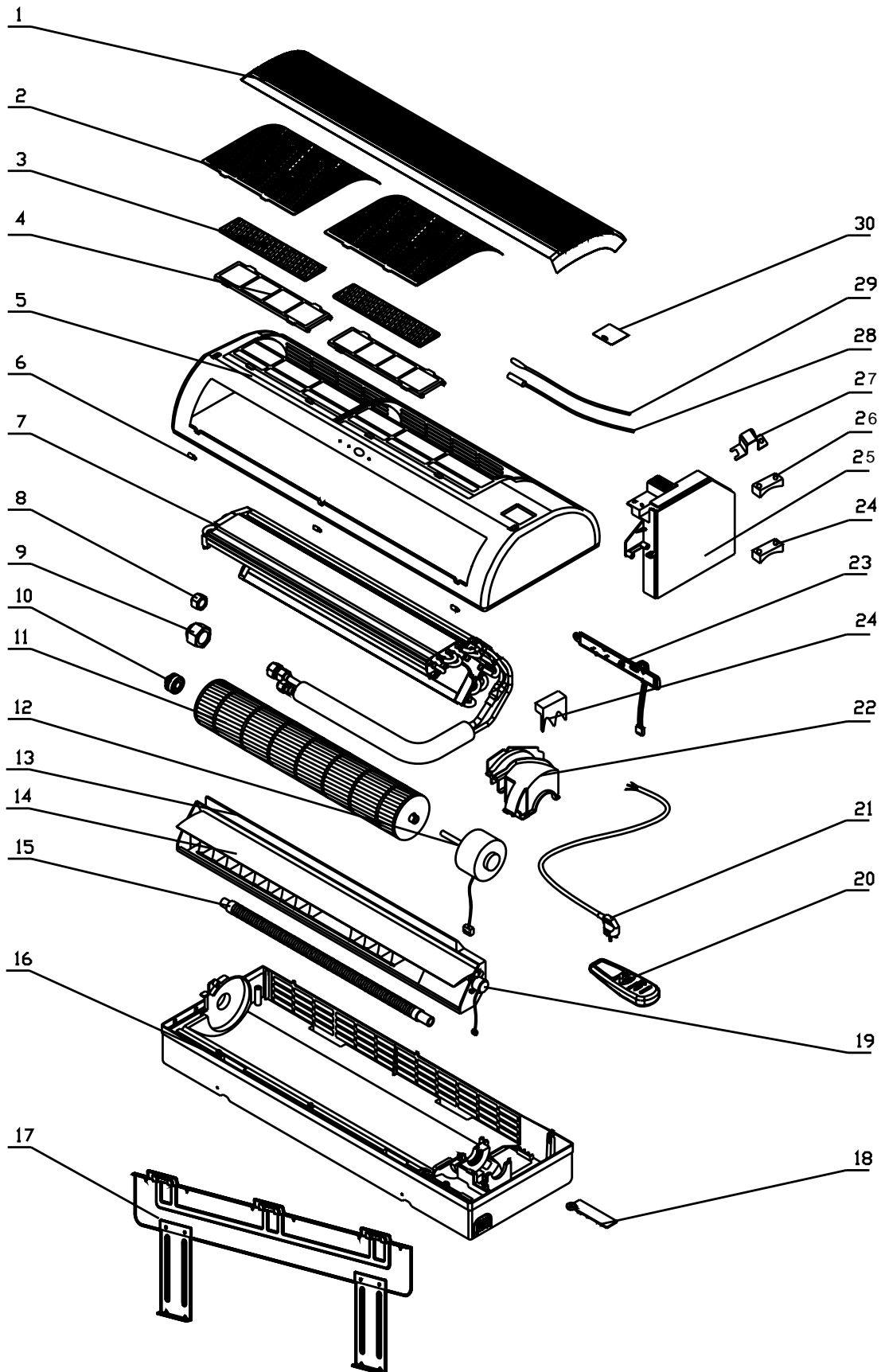

14.2 Indoor Unit Alpha 7, 9

No.	Part No.	Description	Qty
1	4525979	Grille A	1
	4527484	Grille B	1
	4527485	Grille C	1
2	4525989	Air Filter	2
3	4523901	Active Carbon Filter (Optional)	2
4	4525990	Filter Support (Optional)	2
5	4527003	Printing Frame "Electra"for Isreal	1
	4527004	Printing Frame "Fagor"	1
	452700501	Printing Frame "AIWELL"	1
	452700502	Printing Frame "GORNEJE"	1
	452700503	Printing Frame "Belair"	1
	452700504	Printing Frame "Relax"	1
	452700505	Printing Frame "No brand"	1
	452700506	Printing Frame "OCEAN"	1
	452700507	Printing Frame "BOSCH"	1
	452700508	Printing Frame "SIEMENS"	1
	452700509	Printing Frame "Electra"for European	1
452700510	Printing Frame "Climair"	1	
452700511	Printing Frame "Johnson"	1	
6	4525987	Screw Cover	3
7	453070700	Coil Assy.	1
8	126233	Nut brass 1/4"	1
9	434530	Nut brass 3/8"	1
10	4523526	Beraing Assy.	1
11	4523523	Fan Assy. Plastic	1
12	4523505	Motor IOD-7	1
13	4527112	Motor IOD-9	1
	4526649	Air Outlet Assy. (Israel market)	1
	452784400	Air Outlet Assy.(except Israel market)	1
14	4525991	Louver	1
15	4523693	Drain Hose	1
16	4526659	Rear Panel Assy.	1
17	453027400	Mount Bracket	1
18	4526000	Tube Clip	1
19	4523507	Step Motor	1
20	438600	Remote Controller RC3	1
21	412040	Remote Controller RC5-RC	1
	4526132	Power Cord Cable(Isreal)	1
	4526133	Power Cord Cable(Europe 2m)	1
	4524040	Power Cord Cable(Austrilia)	1
	4526134	Power Cord Cable(no plug)	1
4526136	Power Cord Cable(Europe 3m)	1	
22	4525998	Motor Cover	1
23	4516263	Sensor Base	1
24	452778400	Display Assy	1
25	452778300	Control Box Assy.	1
26	453124100	Control Box Assy. (easy connector)	1
	4525988	Cable Locker	1
27	436525	Cable Locker	1
28	438082	Thermistor Indoor Coilblack	1
29	4519813	Thermistor Roomred	1
30	453027000	Terminal Cover	1

14.3 Indoor Unit Alpha 12

No.	Part No.	Description	Qty
1	4527501	Grille A	1
	4527502	Grille B	1
	4527503	Grille C	1
2	4527507	Air Filter	2
3	4527359	Active Carbon Filter (Optional)	2
4	4527508	Filter Support (Optional)	2
5	452766800	Printing Frame "Electra"for Isreal	1
	452766801	Printing Frame "AIRWELL"	1
	452766802	Printing Frame "GORNEJE"	1
	452766803	Printing Frame "Belair"	1
	452766804	Printing Frame "Relax"	1
	452766805	Printing Frame "Electra"for Europent	1
	452766806	Printing Frame "Fagor"	1
	452766807	Printing Frame "No brand"	1
	452766808	Printing Frame "OCEAN"	1
	452766809	Printing Frame "BOSCH"	1
	452766810	Printing Frame "SIEMENS"	1
452766811	Printing Frame "Johnson"	1	
6	4525987	Screw Cover	3
7	453058200	Coil Assy.	1
8	126233	Nut brass 1/4'	1
9	434530	Nut brass 3/8'	1
10	4523526	Beraing Assy.	1
11	4527111	Fan Assy. Plastic	1
12	4527112	Motor IOD-12	1
13	4527187	Air Outlet Assy. (Israel market)	1
	452784401	Air Outlet Assy.(except Israel market)	1
14	4527509	Louver	1
15	4523693	Drain Hose	1
16	4527186	Rear Panel Assy.	1
17	453027500	Mount Bracket	1
18	4527512	Tube Clip	2
19	4523507	Step Motor	1
20	438600	Remote Controller RC3	1
21	412040	Remote Controller RC5-RC	1
	4526132	Power Cord Cable(Isreal)	1
	4526133	Power Cord Cable(Europe 2m)	1
	4524040	Power Cord Cable(Austrilia)	1
	4526134	Power Cord Cable(no plug)	1
	4526136	Power Cord Cable(Europe 3m)	1
22	4525998	Motor Cover	1
23	4516263	Sensor Base	1
24	452778400	Display Assy.	1
25	452778300	Control Box Assy.	1
	453124100	Control Box Assy. (easy connecter)	1
26	4525988	Cable Locker	1
27	436525	Cable Locker	1
28	438082	Thermistor Indoor Coilblack	1
29	4519813	Thermistor Roomred	1
30	453027000	Terminal Cover	1

14.4 Indoor Unit Alpha 7, 9, 12 DF

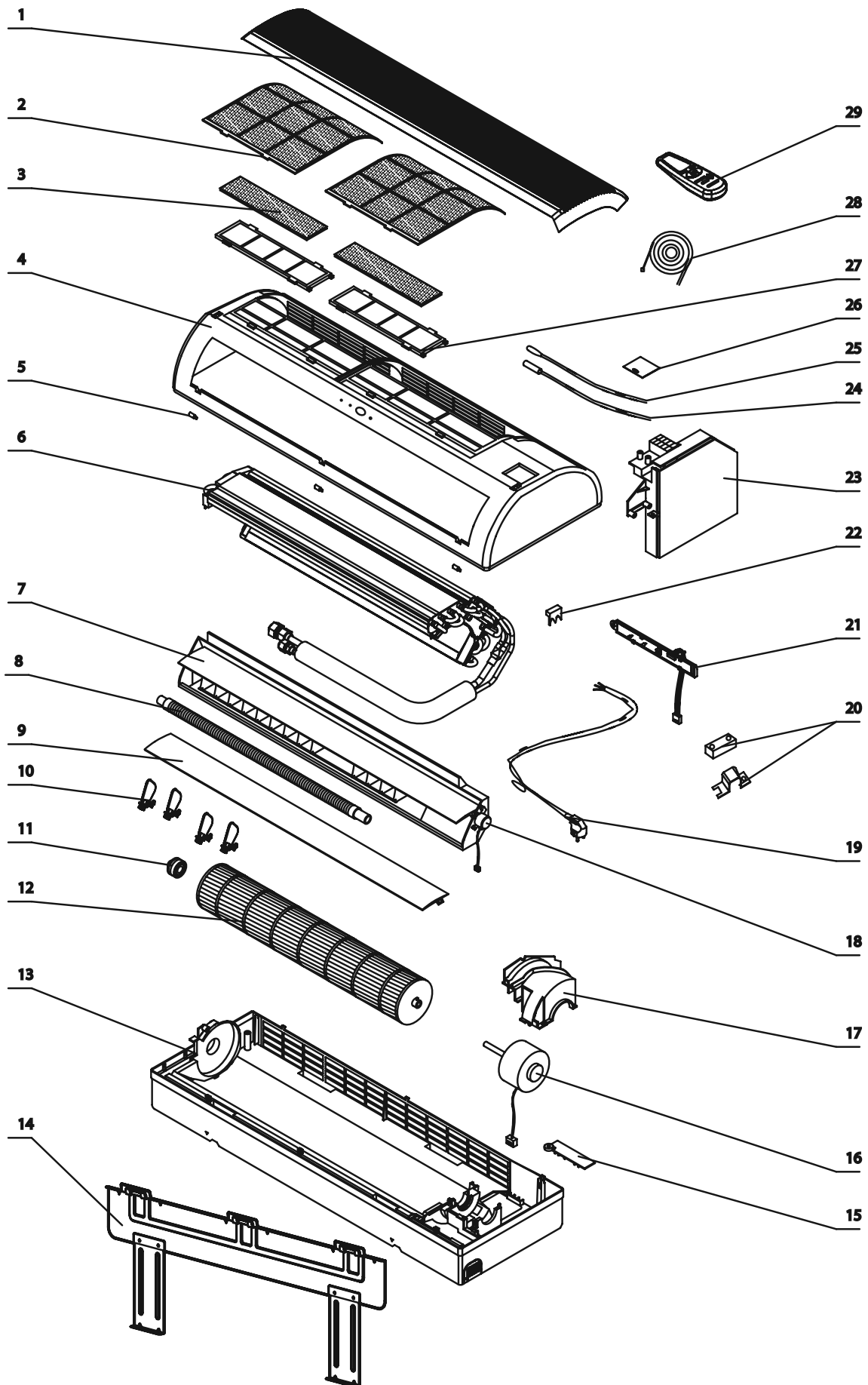

14.5 Indoor Unit Alpha 7 DF

No.	Item Code	Item Description	Quantity
1	465100013	Grill /Alpha 7,9 F	1
2	453036500	Filter for DELTA 7/9	2
4	465720127	Front Frame Assy./Delta F 9	1
5	4525987	SCREW COVER	3
6	453070700	Evap. System Assy./Alfa7,	1
7	4525982	AIR OUTLET FRAME	1
8	4523693	DRAIN HOSE	1
9	4525991	LOUVER	1
10	4525992	VER. FLAP A	8
10	4525993	VER. FLAP B	2
11	4523526	BERAING ASSY FAN	1
12	466020000	ImpellerFan98*510/ALPHA79	1
13	4526659	REAR PANEL ASSY	1
14	464220008	Mount Bracket./Low Cost ALPHA 9	1
15	4526000	TUBE CLIP	1
16	4523505R	Motor	1
17	4525998	MOTEOR COVER	1
18	4523507	Step motor	1
19	455013401R	ISR ISRPowerCord/3G/1.0/2100(187)	1
20	4525988	CABLE LOCKER	1
21	453089600R	Display assy. for DELTA EHK:936A034-00	1
22	4516263	SENSOR BASE	1
23	467300198R	Controller/Delta 7/9/12 S/W:10V14	1
24	438082	Thermistor Indoor	1
25	4519813	Thermistor room	1
26	453027000	Terminal Cover	1
28	4520416	Defrost cable EXPORT UNITS£©	1
29	438600R	Remote controller RC3-RC 973-600-00	1
32	465440009	Frame Left Crank	1
32	465440010	Frame Right Crank	1

14.6 Indoor Unit Alpha 9 DF

No.	Item Code	Item Description	Quantity
1	465100013	Grill /Alpha 7,9 F	1
2	453036500	Filter for DELTA 7/9	2
4	465720127	Front Frame Assy./Delta F 9	1
5	4525987	SCREW COVER	3
6	453070700	Evap. System Assy/Alfa7,	1
7	4525982	AIR OUTLET FRAME	1
8	4523693	DRAIN HOSE	1
9	4525991	LOUVER	1
10	4525992	VER. FLAP A	8
10	4525993	VER. FLAP B	2
11	4523526	BERAING ASSY FAN	1
12	453264200	Impeller Fan	1
13	4526659	REAR PANEL ASSY	1
14	464220008	Mount Bracket./Low Cost ALPHA 9	1
15	4526000	TUBE CLIP	1
16	4527112R	Motor Compact 12	1
17	4525998	MOTEOR COVER	1
18	4523507	Step motor	1
19	455013401R	ISR ISRPowerCord/3G/1.0/2100(187)	1
20	4525988	CABLE LOCKER	1
21	453089600R	Display assy. for DELTA EHK:936A034-00	1
22	4516263	SENSOR BASE	1
23	467300198R	Controller/Delta 7/9/12 S/W:10V14	1
24	438082	Thermistor Indoor	1
25	4519813	Thermistor room	1
26	453027000	Terminal Cover	1
28	4520416	Defrost cable EXPORT UNITS	1
29	438600R	Remote controller RC3-RC 973-600-00	1
32	465440009	Frame Left Crank	1
32	465440010	Frame Right Crank	1

14.7 Indoor Unit Alpha 12 DF

No.	Item Code	Item Description	Quantity
1	465100014	Grill /Alpha 12 F	1
2	453082900	Filter for DELTA 12	2
4	465720128	Front Frame Assy./Delta F 12	1
5	4525987	SCREW COVER	3
6	453058200	Evap. System Assy./Alfa12	1
7	4527506	Air Outlet	1
8	4523693	DRAIN HOSE	1
9	4527509	Horizontal Flap	1
10	4525992	VER. FLAP A	9
10	4527510	Vertical Flap B	3
11	4523526	BERAING ASSY FAN	1
12	4527111	FAN ASSY PLASTIC	1
13	4527186	IOD-12 REAR PANEL ASSY	1
14	464220007	Mount Bracket./Low Cost ALPHA 12	1
15	4526000	TUBE CLIP	1
16	4527112R	Motor Compact 12	1
17	4525998	MOTEOR COVER	1
18	4523507	Step motor	1
19	455013400R	ISR ISRPowerCord/3G/1.5/2100(187)	1
20	4525988	CABLE LOCKER	1
21	453089600R	Display assy. for DELTA EHK:936A034-00	1
22	4516263	SENSOR BASE	1
23	467300198R	Controller/Delta 7/9/12 S/W:10V14	1
24	438082	Thermistor Indoor	1
25	4519813	Thermistor room	1
26	453027000	Terminal Cover	1
28	4520416	Defrost cable EXPORT UNITS	1
29	438600R	Remote controller RC3-RC 973-600-00	1
32	465440009	Frame Left Crank	1
32	465440010	Frame Right Crank	1

14.8 Indoor Unit Alpha 17

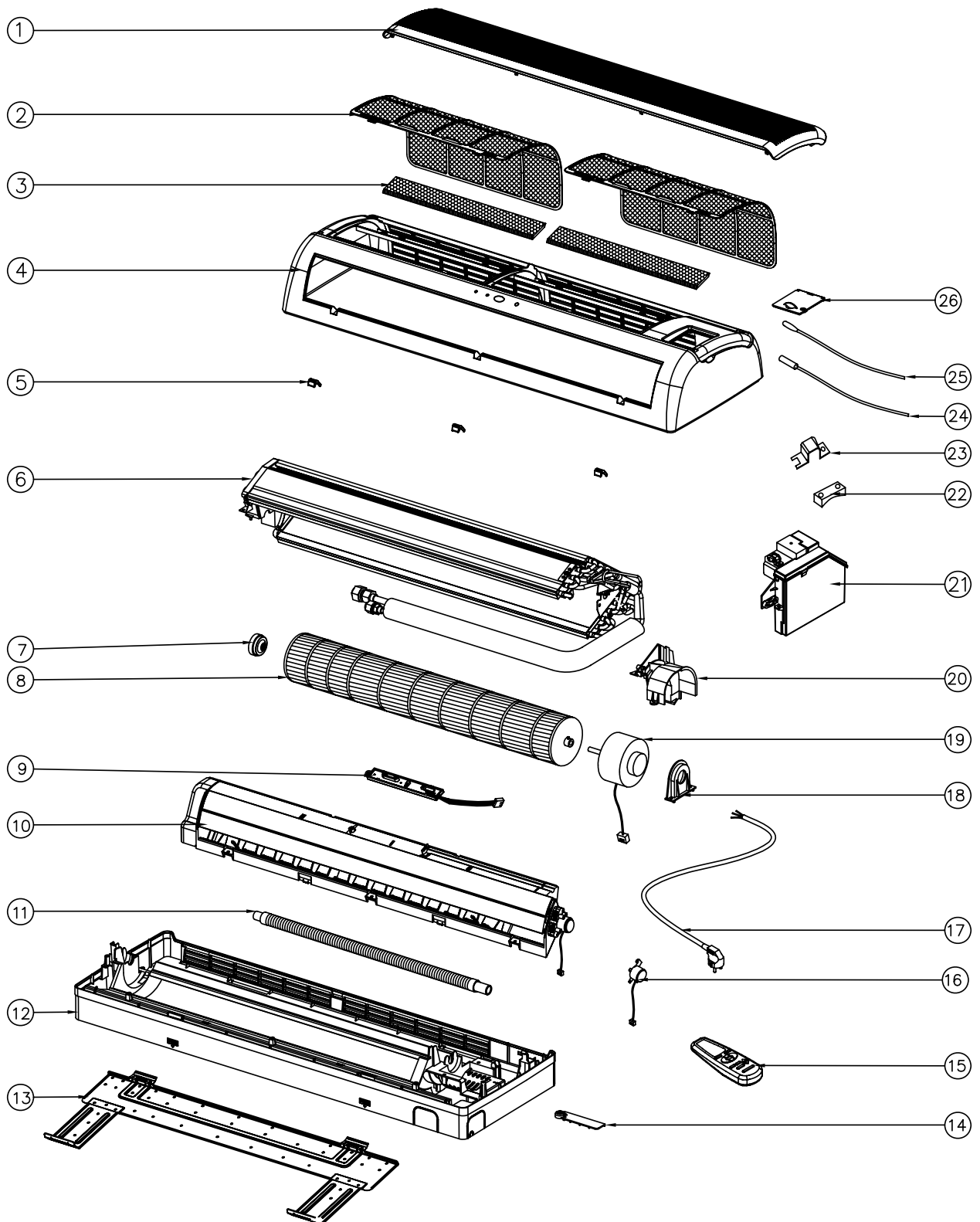

14.9 Indoor Unit Alpha 17

NO.	Part NO.	Name	Quantity
1	453080700	Grill A/ALPHA-17	1
2	453080800	Filter	2
3	4518113	Active Carbon Filter (Optional)	2
4	465720011	Front Frame Assy./ALPHA-17 electra for ISREAL	1
	465720010	Front Frame Assy./ALPHA-17 electra for EURO.	1
	453101700	Front Frame Assy./ALPHA-17 Johnson	1
5	453081000	Screw Cover	3
6	453102200	Evaporator Assy.	1
7	4518662	Bearing assy fan	1
8	453082400	Impeller Fan	1
9	453102000	LED Display assy./ALPHA-17	1
10	453101600	Air Outlet Frame Assy./ALPHA-17	1
11	4518664	Drain hose	1
12	453101400	Unit Housing Assy./ALPHA-17	1
13	453081900	Mount Bracket Assy.	1
14	4526000	TUBE CLIP	1
15	438600	Remote controller RC3-RC 973-600-00	1
16	4523507	Step motor	1
17	452766401	Power Cord European 2m optional	1
	452766400	Power Cord Israel 2m optional	1
18	4518651	Cover Side Motor	1
19	453102100	Resin Motor/ 18W/1200rpm 1000rpm	1
20	452918800	Cover/motor	1
21	453101900	Control Box Assy./ALPHA-17	1
	457300010	Controller/Alpha 17, With 5 Poles of Terminal	1
	457300011	Controller/Alpha 17, With 6 Poles of Terminal	1
22	4525988	CABLE LOCKER	1
23	436525	SUPPLY CORD LATCH WMN	1
24	438082	Thermistor Indoor coil BLACK	1
25	4519813	Thermistor room	1
26	453027000	Terminal Cover	1

14.10 Indoor Unit Delta 17, 24

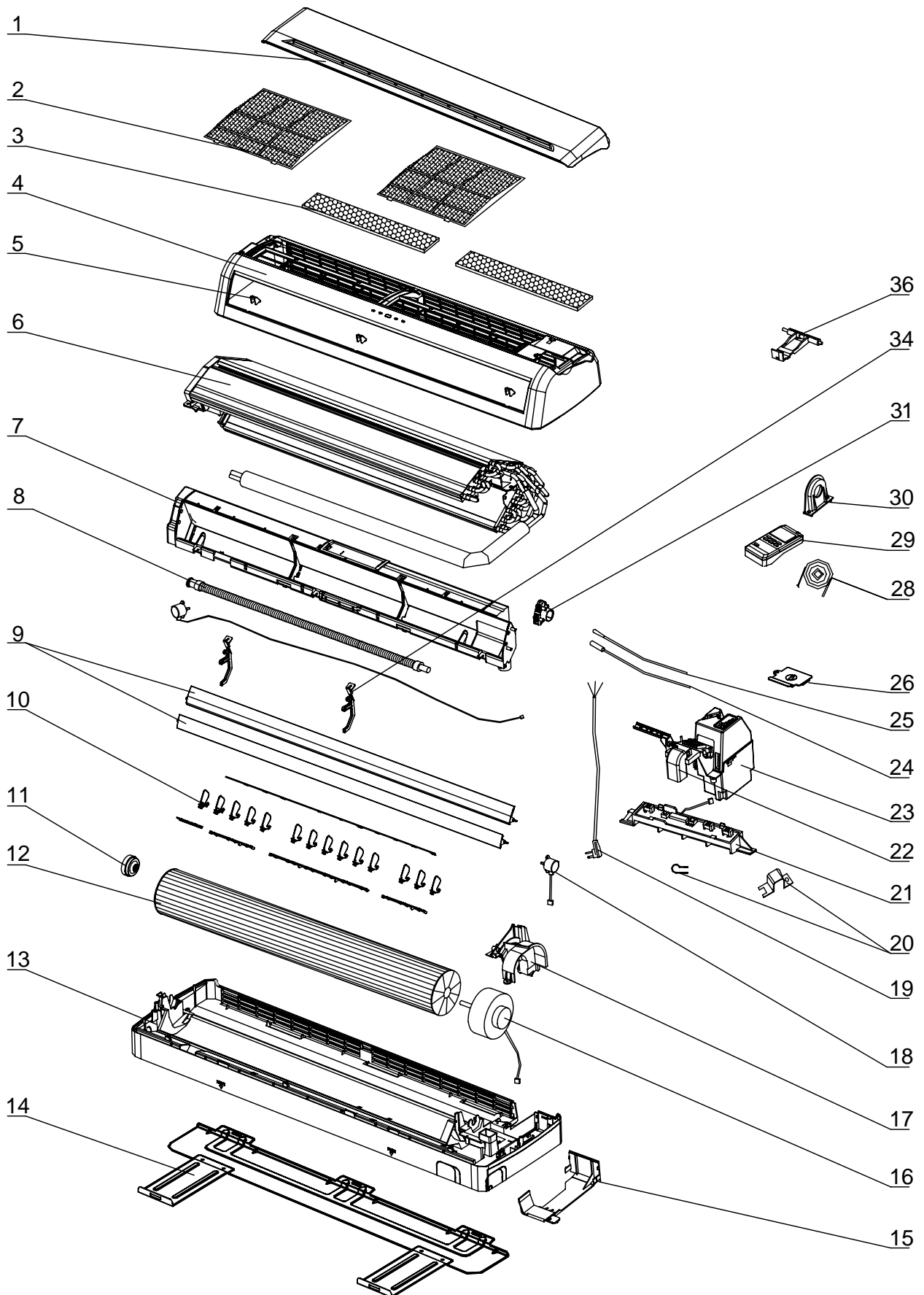

14.11 Indoor Unit Delta 17

No.	Item Code	Item Description	Quantity
1	465100015	Grill /Alpha 17 F	1
2	453080800	Filter	2
4	465720182	Front Frame Assy./ Electra Delta Fix 14	1
5	453081000	Screw Cover	3
6	453102200	Evaporator Assy.	1
7	453081100	Air Outlet Frame	1
8	4518664	Drain hose	1
9	4527509	Horizontal Flap	1
10	453081400	A Vertical Flap A	11
10	453081500	B Vertical Flap B	1
11	4518662	Bearing assy fan	1
12	453082400	Impeller Fan	1
13	453101400	Unit Housing Assy./ALPHA-17	1
14	453081900	Mount Bracket Assy.	1
15	4526000	TUBE CLIP	1
16	453102100R	ResinMotor/18W/1200rpm1000rpm	1
17	452918800	Cover/motor	1
18	4523507	Step motor	1
19	455013400R	ISR ISRPowCord/3G/1.5/2100(187)	1
20	4525988	CABLE LOCKER	1
21	467300007R	Display Board Assy./DELTA EHK: 936A035-0	1
22	4516263	SENSOR BASE	1
23	467300199R	Controller/Delta 17/22 S/W:10V14	1
24	438082	Thermistor Indoor	1
25	4519813	Thermistor room	1
26	453027000	Terminal Cover	1
28	4520416	Defrost cable EXPORT UNITS	1
29	438600R	Remote controller RC3-RC 973-600-00	1
32	465440001	Grill Left Crank	1
32	465440002	Grill Right Crank	1

14.12 Indoor Unit Delta 24

No.	Item Code	Item Description	Quantity
1	465020098	Front Plate/Delta 18&24 Fagor	1
2	452919800	Filter	2
3	4518113	AIR FILTER ASSY	1
4	465720204	Silk-Screen Front Frame Assy./Delta 18-2	1
5	452919600	Screw cover	3
6	462350084	Evaporator Assy./WNG24 R410A	1
7	452917300	Air outlet	1
8	465210009	Drain Pipe for Israel /WNG18/24/30	1
9	452917500	Horizontal flap A	1
9	452917600	Horizontal flap B	1
10	452930700	Vertical flap A	12
10	452918200	Vertical flap B	2
11	4518662	Bearing assy fan	1
12	453024900	Impeller fan	1
13	453053800	Base assy./WNG18	1
14	452920100	Mount bracket/WNG-18	1
15	452919400	Joint/Unit housing	1
16	453134300R	Resin Motor 26W 1300/1200/ 1100 /WNG24 L	1
17	452918800	Cover/motor	1
18	453050300	STEP MOTOR B	1
20	4519147	Power Cord Clip	1
20	452919200	Tie/connection Wire	1
21	467300197R	Display Board/Delta 18 F	1
22	452919100	Support/sensor	1
22	4516263	SENSOR BASE	1
23	467300201R	Controller/Delta F 18 S/W:10V14	1
24	438082	Thermistor Indoor	1
25	467400025	(650mm) Indoor Air Inlet Temperature S	1
26	452919500	Cover/terminal	1
28	4520416	Defrost cable EXPORT UNITS	1
29	438600R	Remote controller RC3-RC 973-600-00	1
30	4518651	Cover Side Motor	1
31	453057900	Gear BOX ASSY	1
34	452918700	Support/horizontal louver	2
36	4518657	TUBE LOCK	1

14.13 Outdoor Unit CON 7 RC

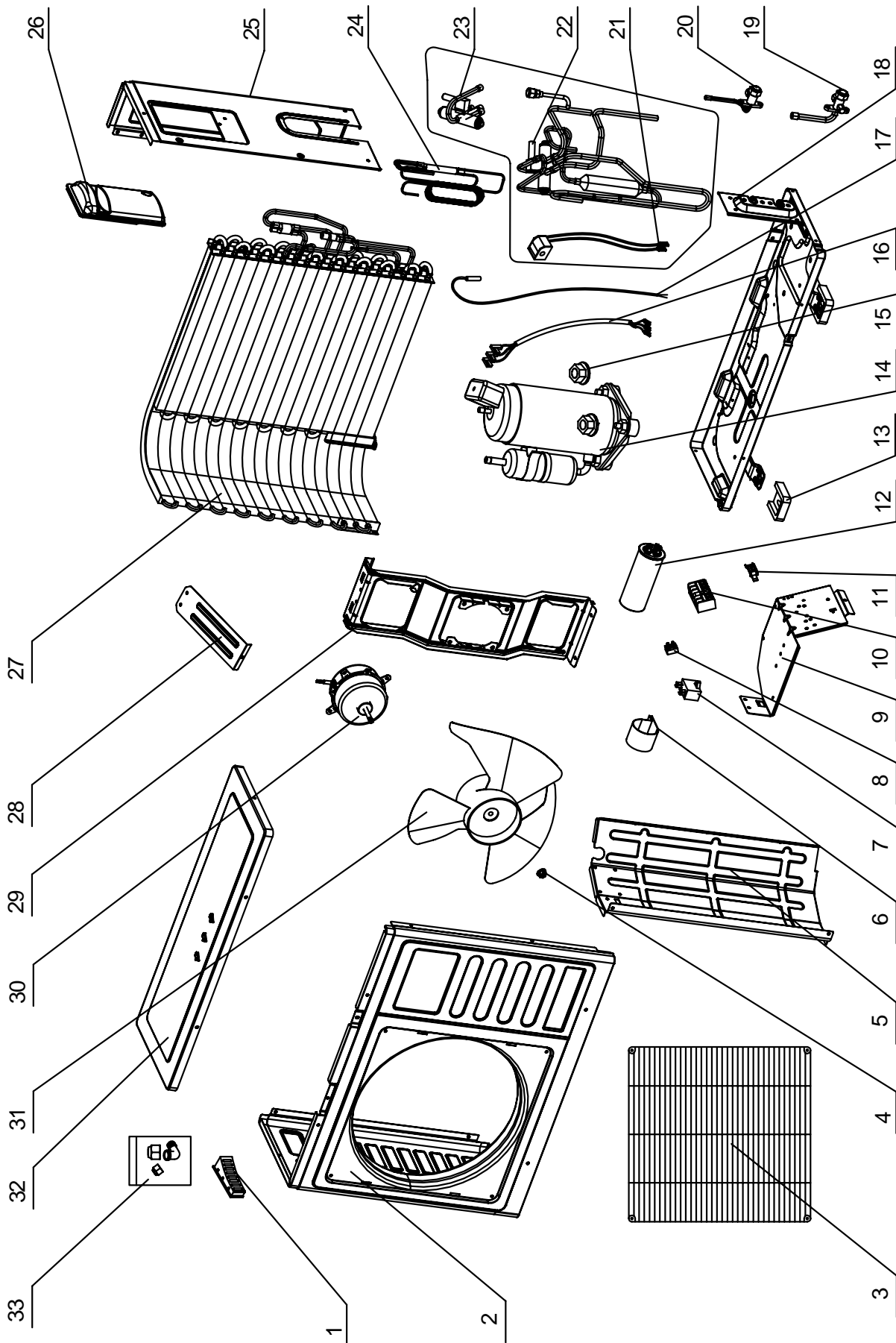

14.14 Outdoor Unit CON 7 RC

No.	Part No.	Description	Qty
1	436358	L.lifter	1
2	4526671	Front Panel	1
3	4526481	CON Outdoor Grille	1
4	4527483	Screw ST4X10-C-H DK>9	1
5	453044400	Partition plate	1
6	4525427	Clip for capacitance	1
7	455000108	Double patch Capacitor for fan motor 2uF	1
8	236179	2 Poles Terminal Block	1
9	453057000	Pedestal/Control	1
10	4514588	5 Poles Terminal Block	1
11	453054500	Clip/cables	1
12	455000502	Compressor Capacitor With Screw 25uF (CBB65)	1
13	453056700	Rubber grommet/base plate	4
14	452964500	Compressor Assy. PA82X1C-4DZDE(R410A GMCC)	1
15	4510677	Nut With Flange M8 -D=24 GB6187-86	3
16	4524278	Wire assy	1
17	4516637	Out sensor Black	1
18	453045400	Base Plate	1
19	453046100	Low Pressure Stop Valve OD9.53 R410A	1
20	453046200	High Pressure Stop Valve OD6.35 R411A	1
21	4520071	4-W Valve coil for R410A	1
22	453044200	4-W Valve Welding assy	1
23	4518951	4-W valve SHF-4H for R410A	1
24	453045600	Capillary assy	1
25	4526669	Side Panel Painting	1
26	4526668	R lifter	1
27	453057500	Condenser Assy	1
28	4526143	Linker of motor support assy	1
29	453045000	Motor Support	1
30	4523609	Motor YDK20-6L	1
31	4523707	AXIAL FAN	1
32	4526675	Top Cover Painting	1
33	453121500	Install Accessory	1

14.15 Outdoor Unit CON 7 ST

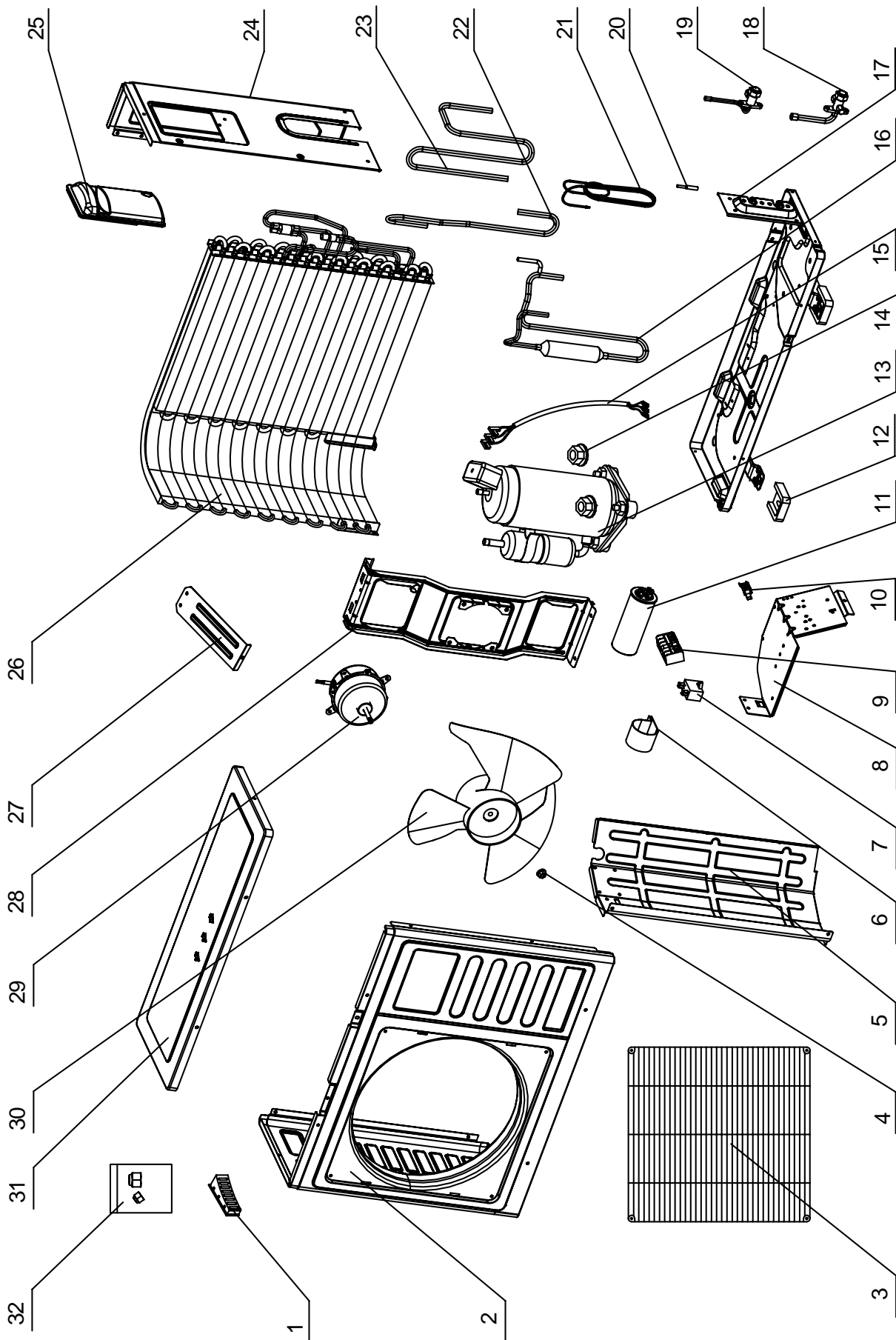

14.16 Outdoor Unit CON 7 ST

No.	Part No.	Description	Qty
1	436358	L.lifter	1
2	4526671	Front Panel	1
3	4526481	CON Outdoor Grille	1
4	4527483	Screw ST4X10-C-H DK>9	1
5	453044400	Partition plate	1
6	4525427	Clip for capacitance	1
7	455000108	Double patch Capacitor for fan motor 2uF	1
8	453057000	Pedestal/Control	1
9	4514588	5 Poles Terminal Block	1
10	453054500	Clip/cables	1
11	455000502	Compressor Capacitor With Screw 25uF (CBB65)	1
12	453056700	Rubber grommet/base plate	4
13	452964500	Compressor Assy. PA82X1C-4DZDE(R410A GMCC)	1
14	4510677	Nut With Flange M8 -D=24 GB6187-86	3
15	4524278	Wire assy	1
16	453183600	Discharge Pipe Assy	1
17	453045400	Base Plate	1
18	453046100	Low Pressure Stop Valve OD9.53 R410A	1
19	453046200	High Pressure Stop Valve OD6.35 R411A	1
20	453112700	Connect Pipe 6.35X0.8	1
21	453126300	Capillary 2.6X1.4X1400	1
22	453112600	Suction Pipe 2	1
23	453112400	Suction Pipe 1	1
24	4526669	Side Panel Painting	1
25	4526668	R lifter	1
26	453057500	Condenser Assy	1
27	4526143	Linker of motor support assy	1
28	453045000	Motor Support	1
29	4523609	Motor YDK20-6L	1
30	4523707	AXIAL FAN	1
31	4526675	Top Cover Painting	1
32	453166600	Install Accessory	1

14.17 Outdoor Unit CON 7 RC with easy connection kit

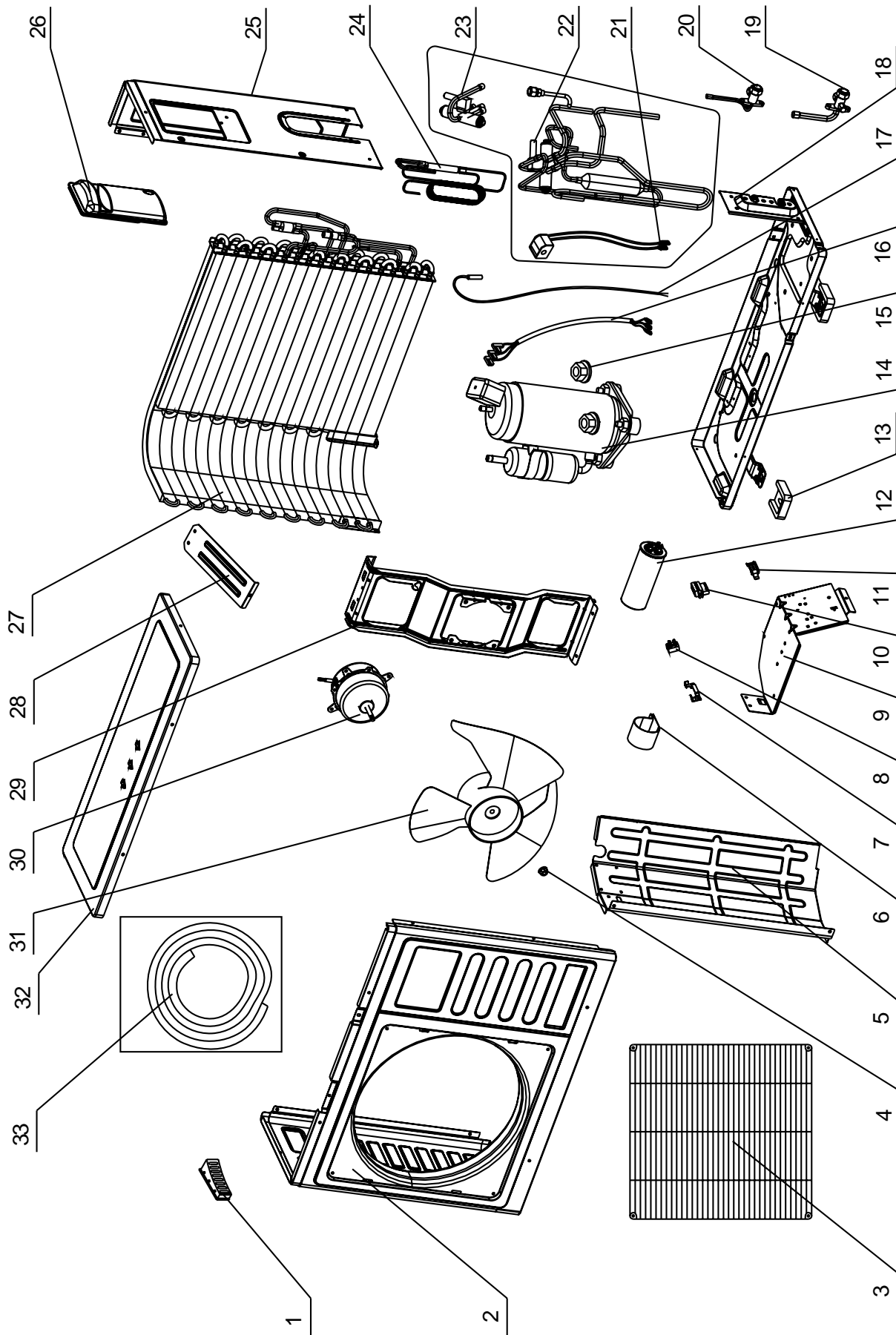

14.18 Outdoor Unit CON 7 RC with easy connection kit

No.	Part No.	Description	Qty
1	436358	L.lifter	1
2	4526671	Front Panel	1
3	4526481	CON Outdoor Grille	1
4	4527483	Screw ST4X10-C-H DK>9	1
5	453044400	Partition plate	1
6	4525427	Clip for capacitance	1
7	453054400	Fixing plate/Terminal Plate	1
8	453057000	Pedestal/Control	1
9	453080600	Terminal Socket/ALPHA Controller	1
10	453054500	Clip/cables	1
11	455000502	Compressor Capacitor With Screw 25uF (CBB65)	1
12	453056700	Rubber grommet/base plate	4
13	452964500	Compressor Assy. PA82X1C-4DZDE(R410A GMCC)	1
14	4510677	Nut With Flange M8 -D=24 GB6187-86	3
15	453112800	Power Cord/Compressor	1
16	453122600	Discharge Pipe Assy	1
17	453045400	Base Plate	1
18	453046100	Low Pressure Stop Valve OD9.53 R410A	1
19	453046200	High Pressure Stop Valve OD6.35 R411A	1
20	453112700	Connect Pipe 6.35X0.8	1
21	453126300	Capillary 2.6X1.4X1400	1
22	453112600	Suction Pipe 2	1
23	453112400	Suction Pipe 1	1
24	4526669	Side Panel Painting	1
25	4526668	R lifter	1
26	453057500	Condenser Assy	1
27	4526143	Linker of motor support assy	1
28	453045000	Motor Support	1
29	453057200	Motor	1
30	4523707	AXIAL FAN	1
31	4526675	Top Cover Painting	1
32	453084800	Connect Pipe Assy./1/4'+3/8'/Alpha7,9,12ST	1

14.19 Outdoor Unit CON 7 ST with easy connection kit

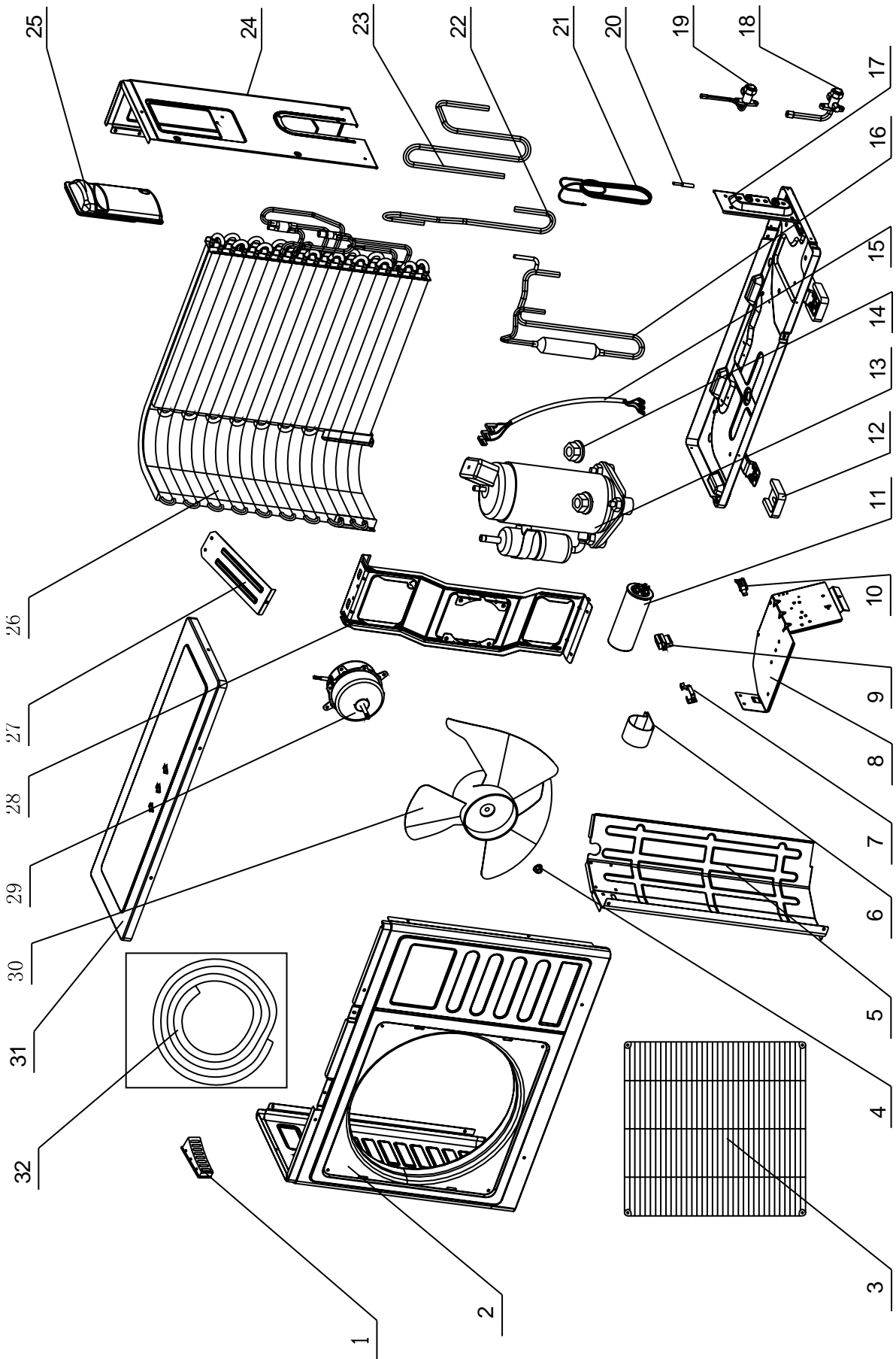

14.20 Outdoor Unit CON 7 ST with easy connection kit

No.	Part No.	Description	Qty
1	436358	L.lifter	1
2	4526671	Front Panel	1
3	4526481	CON Outdoor Grille	1
4	4527483	Screw ST4X10-C-H DK>9	1
5	453044400	Partition plate	1
6	4525427	Clip for capacitance	1
7	453054400	Fixing plate/Terminal Plate	1
8	236179	2 Poles Terminal Block	1
9	453057000	Pedestal/Control	1
10	453080600	Terminal Socket/ALPHA Controller	1
11	453054500	Clip/cables	1
12	455000502	Compressor Capacitor With Screw 25uF (CBB65)	1
13	453056700	Rubber grommet/base plate	4
14	452964500	Compressor Assy. PA82X1C-4DZDE(R410A GMCC)	1
15	4510677	Nut With Flange M8 -D=24 GB6187-86	3
16	453112800	Power Cord/Compressor	1
17	4516637	Out sensor Black	1
18	453045400	Base Plate	1
19	453046100	Low Pressure Stop Valve OD9.53 R410A	1
20	453046200	High Pressure Stop Valve OD6.35 R411A	1
21	453118500	4-W Valve coil/ R410A	1
22	453183700	4-W Valve Welding assy	1
23	4518951	4-W valve SHF-4H for R410A	1
24	453045600	Capillary assy	1
25	4526669	Side Panel Painting	1
26	4526668	R lifter	1
27	453057500	Condenser Assy	1
28	4526143	Linker of motor support assy	1
29	453045000	Motor Support	1
30	453057200	Motor	1
31	4523707	AXIAL FAN	1
32	4526675	Top Cover Painting	1
33	453085100	Connect Pipe Assy./1/4'+3/8'/Alpha7,9,12RC	1

14.21 Outdoor Unit GCN 7 RC R410A A2

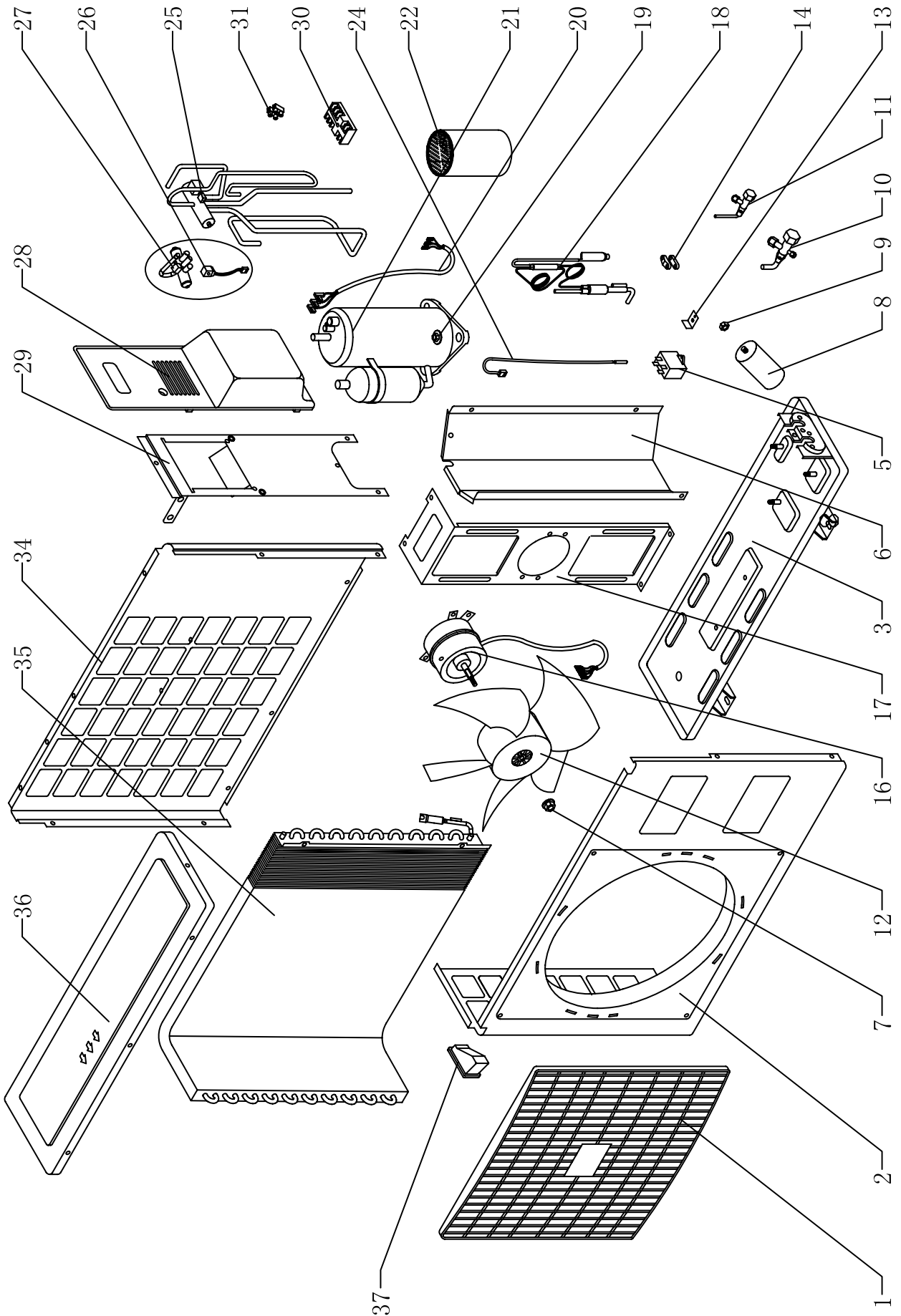

14.22 Outdoor Unit GCN 7 RC R410A A2

No.	Item Code	Item Description	Quantity
1	4522551	Grille A of GCN	1
2	4523441	Front panel A Painting assy	1
3	464600053	Painting Base ASSY.	1
5	455000108	Double patch Capacitor for fan	1
6	464160018	Partition plate/GCZ 9/12	1
8	455000502	Compressor Capacitor 35uF With Screw	1
10	453047000	Low pressure stop valve for R410A	1
11	453046900	High pressure stop valve for R410A	1
12	4519251	Axial Fan OD=400	1
13	4518022	Cap. Clip	1
14	204107	Cable clip Nylon	1
16	4522766R	Motor of outdoor (830rpm)	1
17	464860002	Motor Support Assy.	1
18	463600038	CapillaryAssy.2.6*1.4*(10002400)/GCN7RCR	1
19	201019	Nut M8	3
20	391498	Wire assy	1
21	452964500	Compressor Assy. PA82X1C-4DX2	1
22	469100003	Insulation Felt/ Compressor	1
24	4516637	Out sensor Black	1
25	461600049	4-Way Valve Assy./GCN 7RC R410A	1
26	4520071	4-W valve coil for R410A	1
27	4518951	4-W valve SHF-4H for R410A	1
28	4516857	BIG SIDE COVER	1
29	453086200	Side Plate Painting Assy.	1
29	464770007	Rear Plate/Right Painting Assy/GCZ 9/12	1
30	4514588	5 Poles terminal block	1
31	236179	2 Poles terminal block	1
34	464770001	Rear Plate/Left Painting Assy	1
34	464800000	Guard Net/ODU Painting Assy	1
35	462300037	Condenser Assy/GCZ 12	1
36	4516158	Cover panel Painting assy	1
37	436358	L. lifter	1
38	453085800	Connect Plate/Motor Support	1

14.23 Outdoor Unit GCN 9, 12 RC

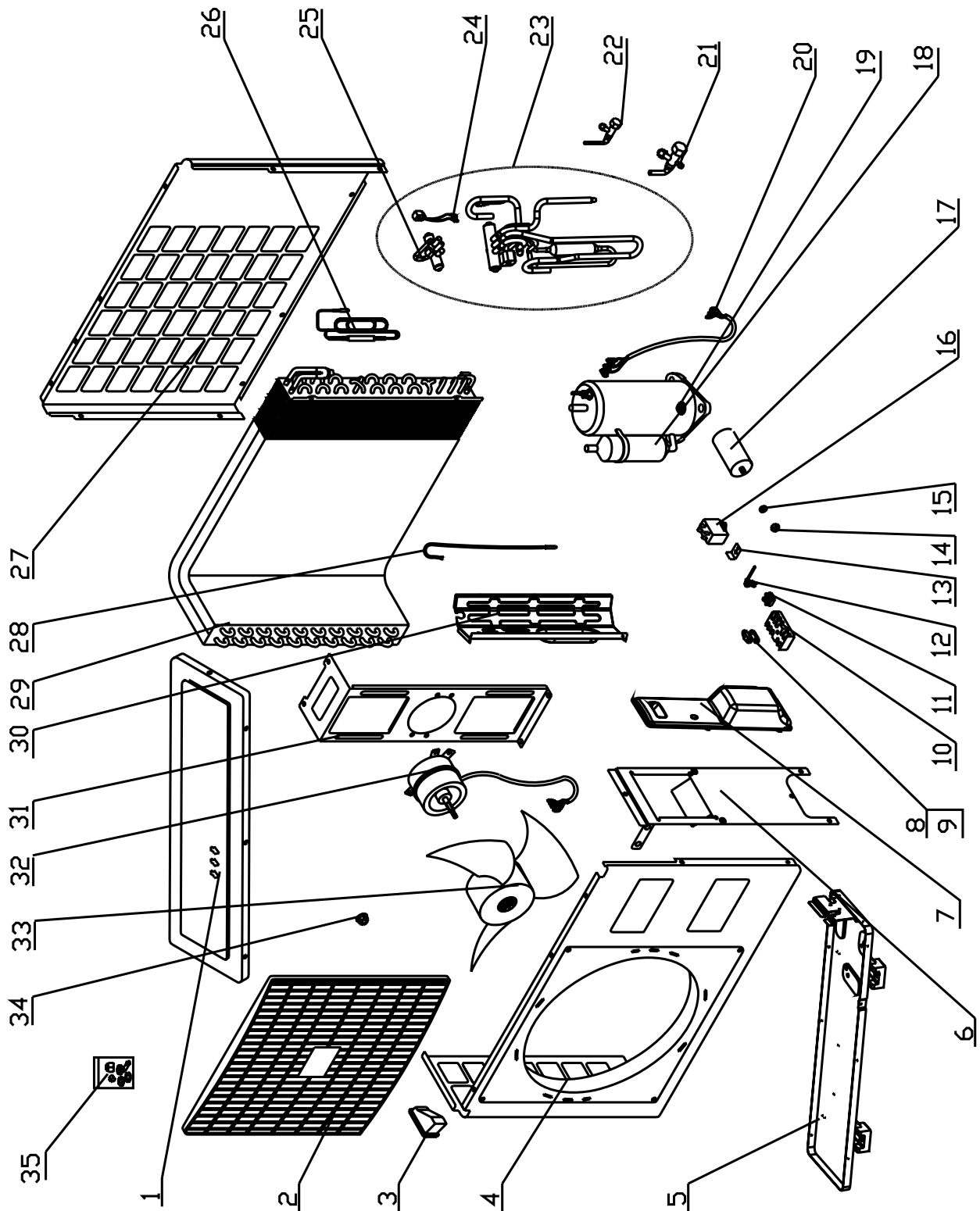

14.24 Outdoor Unit GCN 9 RC

No.	Part No.	Description	Qty
1	4516158	PAINTED COVER PANEL ASSY.	1
2	4522551	Grill A of GCN	1
3	436358	Left Handle	1
4	4523441	Front Panel A Painting Assy.	1
5	4516907	Base Painting Assy.	1
6	453086200	Side Plate Painting Assy.	1
7	4516857	Big Side Cover	1
8	204107	Cable Clip Nylon	1
9	253046	Clip set PVC	1
10	236332	6 Poles Terminal Block	1
11	236179	2 Poles Terminal Block	1
12	4511168	Wire Clip	1
13	4518022	Cap. Clip	1
14	201130	Nut (For Capacitor)	1
15	203008	Washer (For Capacitor)	1
16	455000108	Double patch Capacitor for fan motor 2uF	1
17	455000502	Compressor Capacitor With Screw 25uF (CBB65)	1
18	453090300	Compressor Assy. PA-108X1C-4FZDE	1
19	452795300	Nut With Flange M6	3
20	391498	Wire assy	1
21	453047000	Gas Valve	1
22	453046900	Liquid Valve	1
23	453091500	4-Way Valve System Assy.	1
24	4520071	4-Way Valve coil	1
25	4518951	4-Way Valve	1
26	453091600	Capillary assy	1
27	4516156	Back Panel	1
28	4516637	Outdoor Unit Sensor	1
29	453090700	Condensor Assy.	1
30	453086000	Patition Plate	1
31	323156	Motor Support	1
32	4522765	Fan Motor	1
33	4519251	Fan	1
34	4519300	Nut M8 (For Fan)	1
35	453166600	Install Accessory	1

14.25 Outdoor Unit GCN 12 RC

No.	Part No.	Description	Qty
1	4516158	PAINTED COVER PANEL ASSY.	1
2	4522551	Grill A of GCN	1
3	436358	Left Handle	1
4	4523441	Front Panel A Painting Assy.	1
5	4523862	Base Painting Assy.	1
6	453086200	Side Plate Painting Assy.	1
7	4516857	Big Side Cover	1
8	204107	Cable Clip Nylon	1
9	253046	Clip set PVC	1
10	236332	6 Poles Terminal Block	1
11	236179	2 Poles Terminal Block	1
12	4511168	Wire Clip	1
13	4518022	Cap. Clip	1
14	201130	Nut (For Capacitor)	1
15	203008	Washer (For Capacitor)	1
16	455000108	Double patch Capacitor for fan motor 2uF	1
17	455000504	Compressor Capacitor With Screw 35uF (CBB65)	1
18	4526452	Comp. Assy PA145X2C-4FT	1
19	4510677	Nut With Flange M8 -D=24 GB6187-86	3
20	391498	Wire assy	1
21	453047000	Gas Valve	1
22	453046900	Liquid Valve	1
23	453092700	4-Way Valve System Assy.	1
24	4520071	4-Way Valve coil	1
25	4518952	4-Way Valve	1
26	453092800	Capillary assy	1
27	4516156	Back Panel	1
28	4516637	Outdoor Unit Sensor	1
29	453092100	Condensor Assy.	1
30	453086000	Patition Plate	1
31	323156	Motor Support	1
32	4522766	Fan Motor	1
33	4519251	Fan	1
34	4519300	Nut M8 (For Fan)	1
35	453166600	Install Accessory	1

14.26 Outdoor Unit GCN 9,12 ST

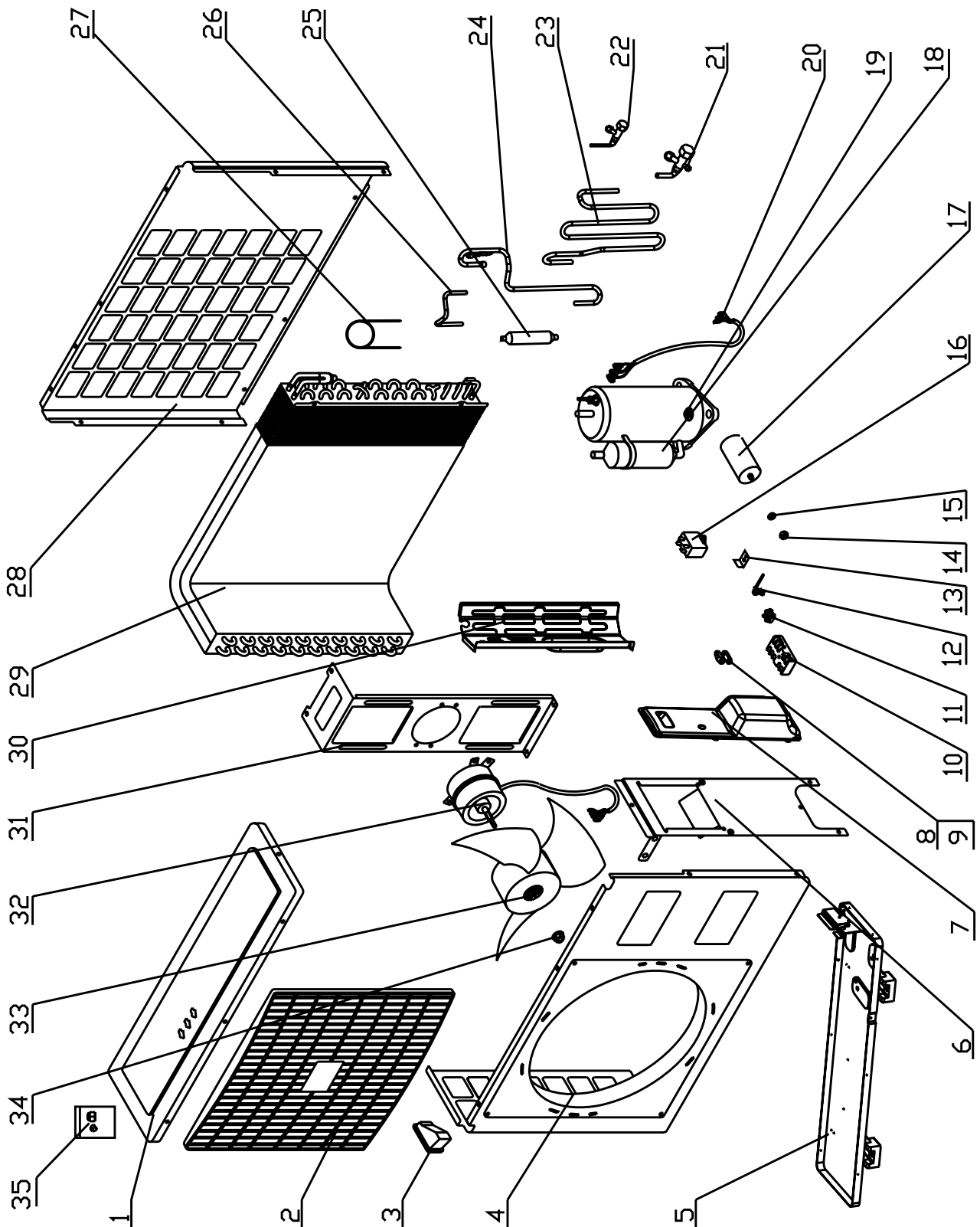

14.27 Outdoor Unit GCN 9 ST

No.	Part No.	Description	Qty
1	4516158	PAINTED COVER PANEL ASSY.	1
2	4522551	Grill A of GCN	1
3	436358	Left Handle	1
4	4523441	Front Panel A Painting Assy.	1
5	4516907	Base Painting Assy.	1
6	453086200	Side Plate Painting Assy.	1
7	4516857	Big Side Cover	1
8	204107	Cable Clip Nylon	1
9	253046	Clip set PVC	1
10	236332	6 Poles Terminal Block	1
11	236179	2 Poles Terminal Block	1
12	4511168	Wire Clip	1
13	4518022	Cap. Clip	1
14	201130	Nut (For Capacitor)	1
15	203008	Washer (For Capacitor)	1
16	455000108	Double patch Capacitor for fan motor 2uF	1
17	455000502	Compressor Capacitor With Screw 25uF (CBB65)	1
18	453090300	Compressor Assy. PA-108X1C-4FZDE	1
19	452795300	Nut With Flange M6	3
20	391498	Wire assy	1
21	453047000	Gas Valve	1
22	453046900	Liquid Valve	1
23	453086900	Suction tube	1
24	453087000	Discharge 1	1
25	4526865	Muffle	1
26	453091300	Discharge 2	1
27	453121700	Capillary	1
28	4516156	Back Panel	1
29	453090700	Condensor Assy.	1
30	453086000	Patition Plate	1
31	323156	Motor Support	1
32	4522765	Fan Motor	1
33	4519251	Fan	1
34	4519300	Nut M8 (For Fan)	1
35	453166600	Install Accessory	1

14.28 Outdoor Unit GCN 12 ST

No.	Part No.	Description	Qty
1	4516158	PAINTED COVER PANEL ASSY.	1
2	4522551	Grill A of GCN	1
3	436358	Left Handle	1
4	4523441	Front Panel A Painting Assy.	1
5	4523862	Base Painting Assy.	1
6	453086200	Side Plate Painting Assy.	1
7	4516857	Big Side Cover	1
8	204107	Cable Clip Nylon	1
9	253046	Clip set PVC	1
10	236332	6 Poles Terminal Block	1
11	236179	2 Poles Terminal Block	1
12	4511168	Wire Clip	1
13	4518022	Cap. Clip	1
14	201130	Nut (For Capacitor)	1
15	203008	Washer (For Capacitor)	1
16	455000108	Double patch Capacitor for fan motor 2uF	1
17	455000504	Compressor Capacitor With Screw 35uF (CBB65)	1
18	4526452	Comp. Assy PA145X2C-4FT	1
19	4510677	Nut With Flange M8 -D=24 GB6187-86	3
20	391498	Wire assy	1
21	453047000	Gas Valve	1
22	453046900	Liquid Valve	1
23	453087500	Suction tube	1
24	453087600	Discharge 1	1
25	453091000	Muffle	1
26	453092500	Discharge 2	1
27	4516156	Capillary	1
28	4516156	Back Panel	1
29	453092100	Condensor Assy.	1
30	453086000	Patition Plate	1
31	323156	Motor Support	1
32	4522766	Fan Motor	1
33	4519251	Fan	1
34	4519300	Nut M8 (For Fan)	1
35	453166600	Install Accessory	1

14.29 Outdoor Unit GCN 9, 12 RC with easy connection kit

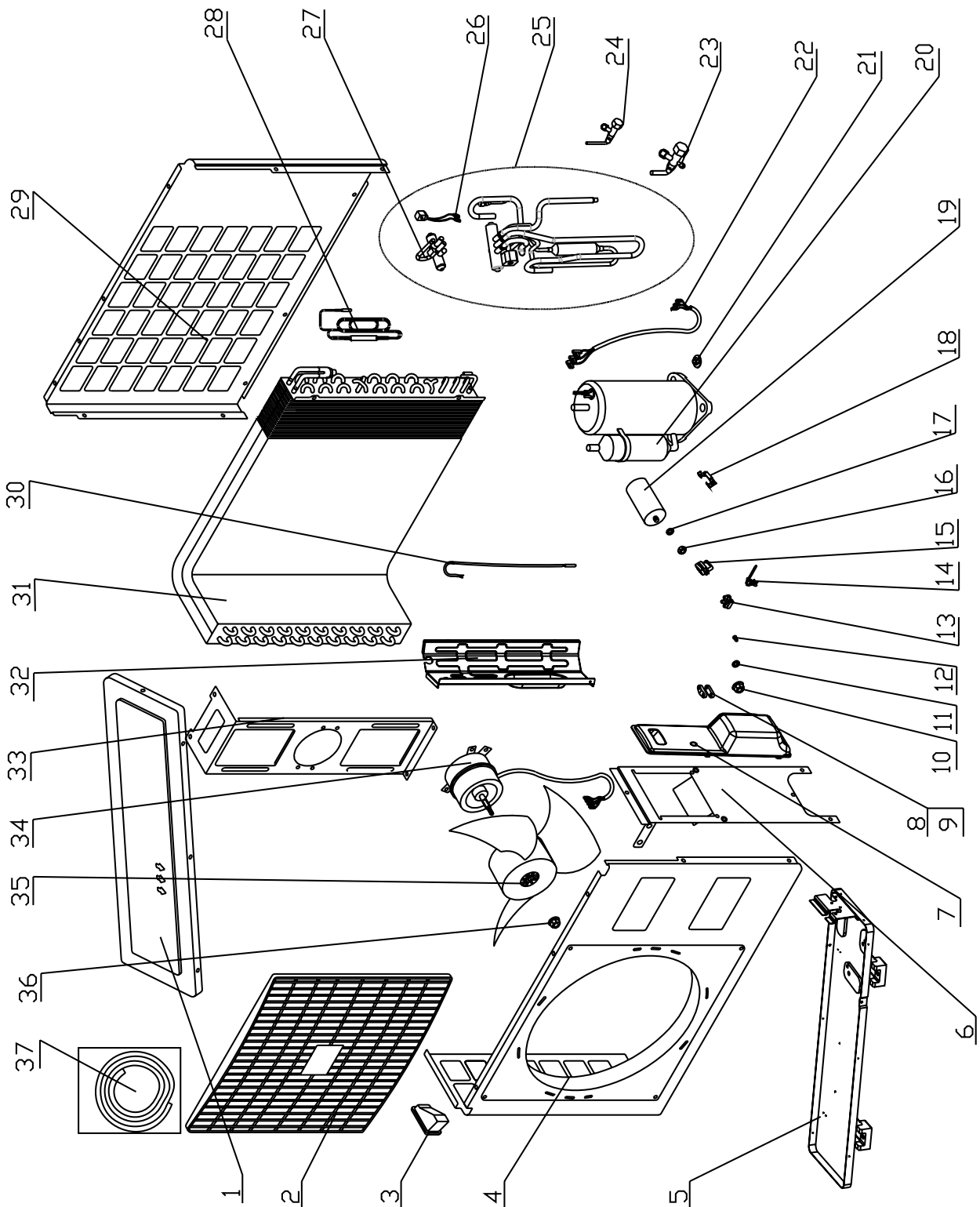

14.30 Outdoor Unit GCN 9 RC with easy connection kit

No.	Part No.	Description	Qty
1	4516158	PAINTED COVER PANEL ASSY.	1
2	4522551	Grill A of GCN	1
3	436358	Left Handle	1
4	4523441	Front Panel A Painting Assy.	1
5	4516907	Base Painting Assy.	1
6	453086200	Side Plate Painting Assy.	1
7	4516857	Big Side Cover	1
8	204107	Cable Clip Nylon	1
9	253046	Clip set PVC	1
10	170906	Brass Hex Nut GB6170	2
11	170466	Washer star GB862.2 ϕ 4	2
12	170716	Screw M4x12 GB818-76	2
13	236179	2 Poles Terminal Block	1
14	4511168	Wire Clip	1
15	453080600	Terminal Socket/ Alpha Controller	1
16	201130	Nut (For Capacitor)	1
17	203008	Washer (For Capacitor)	1
18	453054400	Fixing plate/Terminal plate	1
19	455001002	Combinated Capacitor With Screw (25+2) μ F (CBB65)	1
20	453090300	Compressor Assy. PA-108X1C-4FZDE	1
21	452795300	Nut With Flange M6	3
22	453112800	Wire assy	1
23	453047000	Gas Valve	1
24	453046900	Liquid Valve	1
25	453182300	4-Way Valve System Assy.	1
26	4520071	4-Way Valve coil	1
27	4518951	4-Way Valve	1
28	453091600	Capillary assy	1
29	4516156	Back Panel	1
30	4516637	Outdoor Unit Sensor	1
31	453090700	Condensor Assy.	1
32	453086000	Patition Plate	1
33	323156	Motor Support	1
34	453114100	Fan Motor	1
35	4519251	Fan	1
36	4519300	Nut M8 (For Fan)	1
37	453085100	Connect Pipe Assy./1/4'+3/8'/Alpha7,9,12RC	1

14.31 Outdoor Unit GCN 12 RC with easy connection kit

No.	Part No.	Description	Qty
1	4516158	PAINTED COVER PANEL ASSY.	1
2	4522551	Grill A of GCN	1
3	436358	Left Handle	1
4	4523441	Front Panel A Painting Assy.	1
5	4523862	Base Painting Assy.	1
6	453086200	Side Plate Painting Assy.	1
7	4516857	Big Side Cover	1
8	204107	Cable Clip Nylon	1
9	253046	Clip set PVC	1
10	170906	Brass Hex Nut GB6170	2
11	170466	Washer star GB862.2 φ4	2
12	170716	Screw M4x12 GB818-76	2
13	236179	2 Poles Terminal Block	1
14	4511168	Wire Clip	1
15	453080600	Terminal Socket/ Alpha Controller	1
16	201130	Nut (For Capacitor)	1
17	203008	Washer (For Capacitor)	1
18	453054400	Fixing plate/Terminal plate	1
19	455001001	Combinated Compressor Capacitor With Screw (35+2)u	1
20	4526452	Comp. Assy PA145X2C-4FT	1
21	4510677	Nut With Flange M8 -D=24 GB6187-86	3
22	391498	Wire assy	1
23	453047000	Gas Valve	1
24	453046900	Liquid Valve	1
25	453182400	4-Way Valve System Assy.	1
26	453121400	4-Way Valve coil	1
27	4518952	4-Way Valve	1
28	453092800	Capillary assy	1
29	4516156	Back Panel	1
30	4516637	Outdoor Unit Sensor	1
31	453092100	Condensor Assy.	1
32	453086000	Patition Plate	1
33	323156	Motor Support	1
34	453114200	Fan Motor	1
35	4519251	Fan	1
36	4519300	Nut M8 (For Fan)	1

14.32 Outdoor Unit GCN 9, 12 ST with easy connection kit

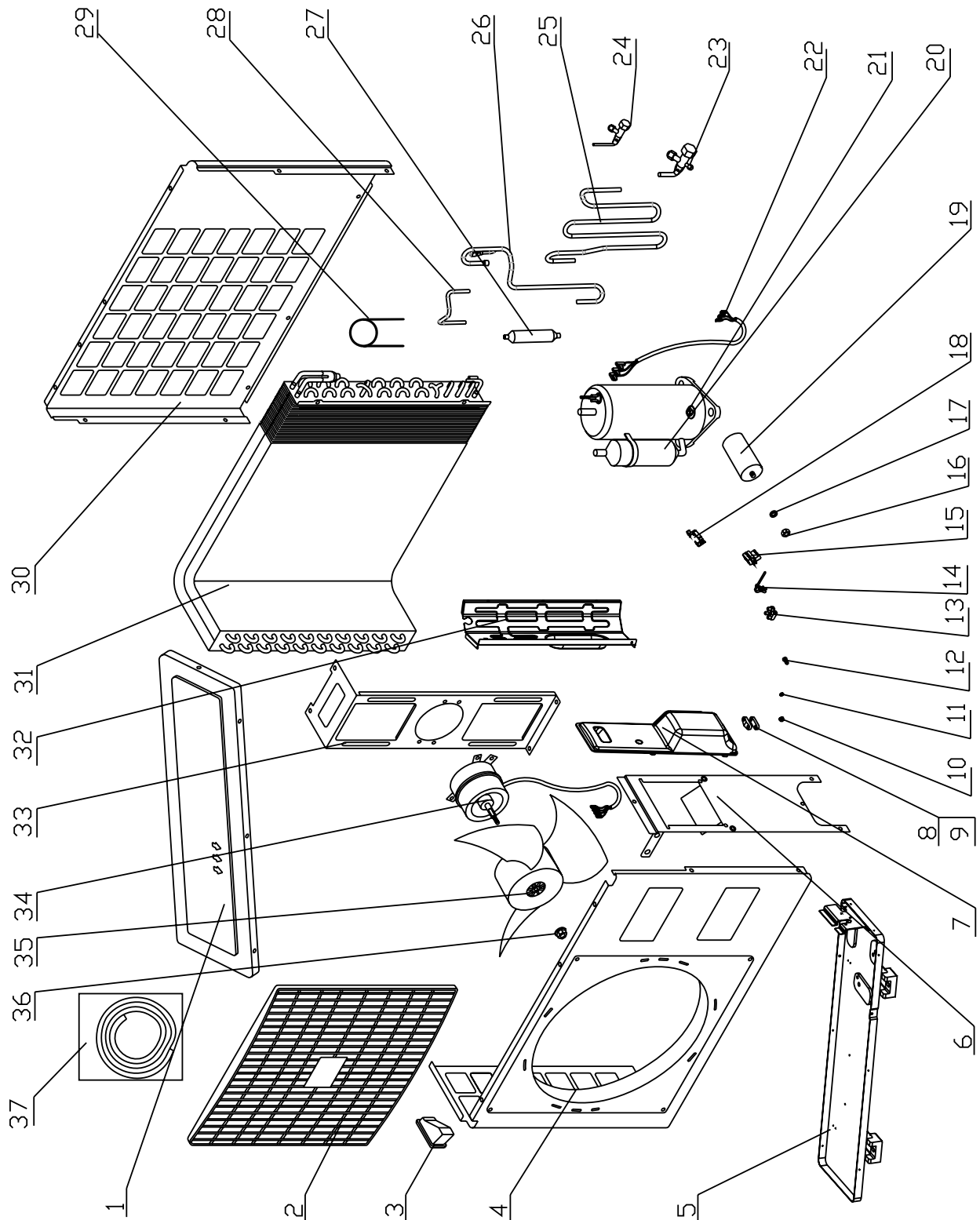

14.33 Outdoor Unit GCN 9 ST with easy connection kit

No.	Part No.	Description	Qty
1	4516158	PAINTED COVER PANEL ASSY.	1
2	4522551	Grill A of GCN	1
3	436358	Left Handle	1
4	4523441	Front Panel A Painting Assy.	1
5	4516907	Base Painting Assy.	1
6	453086200	Side Plate Painting Assy.	1
7	4516857	Big Side Cover	1
8	204107	Cable Clip Nylon	1
9	253046	Clip set PVC	1
10	170906	Brass Hex Nut GB6170	2
11	170466	Washer star GB862.2 ϕ 4	2
12	170716	Screw M4x12 GB818-76	2
13	236179	2 Poles Terminal Block	1
14	4511168	Wire Clip	1
15	453080600	Terminal Socket/ Alpha Controller	1
16	201130	Nut (For Capacitor)	1
17	203008	Washer (For Capacitor)	1
18	453054400	Fixing plate/Terminal plate	1
19	455001002	Combinated Capacitor With Screw (25+2) μ F (CBB65)	1
20	453090300	Compressor Assy. PA-108X1C-4FZDE	1
21	452795300	Nut With Flange M6	3
22	453112800	Wire assy	1
23	453047000	Gas Valve	1
24	453046900	Liquid Valve	1
25	453086900	Suction tube	1
26	453087000	Discharge 1	1
27	4526865	Muffle	1
28	453091300	Discharge 2	1
29	453121700	Capillary	1
30	4516156	Back Panel	1
31	453090700	Condensor Assy.	1
32	453086000	Patition Plate	1
33	323156	Motor Support	1
34	453114100	Fan Motor	1
35	4519251	Fan	1
36	4519300	Nut M8 (For Fan)	1
37	453085100	Connec	2RC

14.34 Outdoor Unit GCN 12 ST with easy connection kit

No.	Part No.	Description	Qty
1	4516158	PAINTED COVER PANEL ASSY.	1
2	4522551	Grill A of GCN	1
3	436358	Left Handle	1
4	4523441	Front Panel A Painting Assy.	1
5	4523862	Base Painting Assy.	1
6	453086200	Side Plate Painting Assy.	1
7	4516857	Big Side Cover	1
8	204107	Cable Clip Nylon	1
9	253046	Clip set PVC	1
10	170906	Brass Hex Nut GB6170	2
11	170466	Washer star GB862.2 ϕ 4	2
12	170716	Screw M4x12 GB818-76	2
13	236179	2 Poles Terminal Block	1
14	4511168	Wire Clip	1
15	453080600	Terminal Socket/ Alpha Controller	1
16	201130	Nut (For Capacitor)	1
17	203008	Washer (For Capacitor)	1
18	453054400	Fixing plate/Terminal plate	1
19	455001001	Combinated Compressor Capacitor With Screw (35+2) μ F (CBB65)	1
20	4526452	Comp. Assy PA145X2C-4FT	1
21	4510677	Nut With Flange M8 -D=24 GB6187-86	3
22	391498	Wire assy	1
23	453047000	Gas Valve	1
24	453046900	Liquid Valve	1
25	453182400	4-Way Valve System Assy.	1
26	453121400	4-Way Valve coil	1
27	4518952	4-Way Valve	1
28	453092800	Capillary assy	1
29	4516156	Back Panel	1
30	4516637	Outdoor Unit Sensor	1
31	453092100	Condensor Assy.	1
32	453086000	Patition Plate	1
33	323156	Motor Support	1
34	453114200	Fan Motor	1
35	4519251	Fan	1
36	4519300	Nut M8 (For Fan)	1
37	453085100	Connect Pipe Assy./1/4'+3/8'/Alpha7,9,12RC	1

14.35 Outdoor Unit ONG3-9, 12, 14 RC R410A

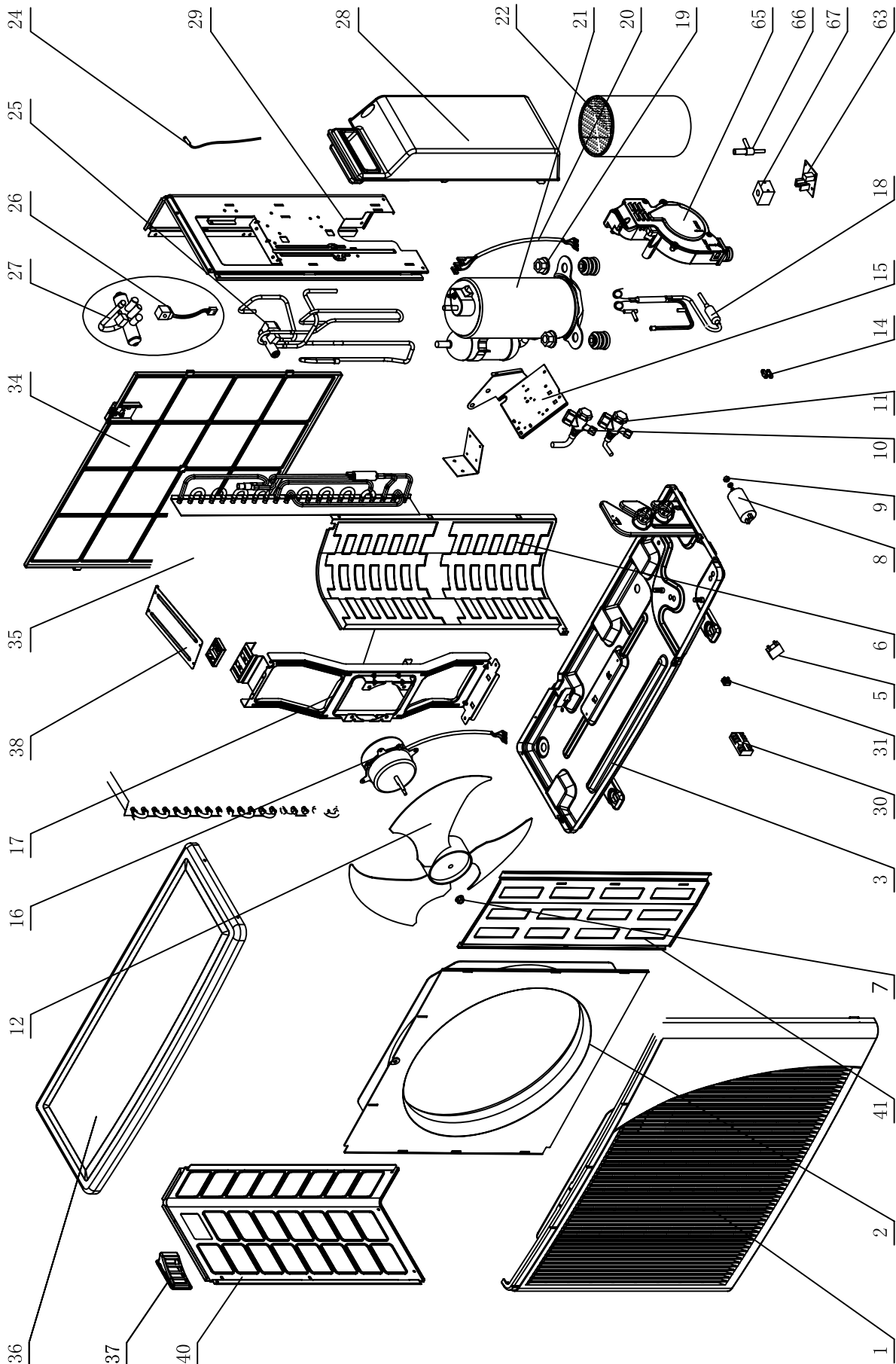

14.36 Outdoor Unit ONG3-9 RC R410A B2

No.	Item Code	Item Description	Quantity
1	433218	Front Panel A	1
2	433221	Air Inlet Ring-420	1
3	4523060	Base Painting Assy.	1
5	455000108	Double patch Capacitor for fan	1
6	433217	Partition Plate	1
7	4519300	Nut M5 L	1
8	455000502	Compressor Capacitor 35uF With Screw	1
9	201019	Nut M8	1
10	4524177	3/8 Gas Valve(R410A)	1
11	4526301	High pressure stop valve R410a	1
12	4519251	Axial Fan OD=400	1
14	204107	Cable clip Nylon	1
15	453012700	Electric Panel	1
16	4519250R	Fan Motor YDK30-6V	1
17	4527203	Motor Support	1
18	463600033	CapillaryAssy.2.6*1.4*(8001400)/ONG3-9R4	1
19	4510677	Nut With Flange M8 -D=24	3
20	391498	Wire assy	1
21	460170001R	Compressor Assy./ PA103X1C-4DZDE	1
22	469100003	Insulation Felt/ Compressor	1
24	4516637	Out sensor Black	1
25	461600052	4-Way Valve Assy/ONG3-9RC R410A.	1
26	4520071	4-W valve coil for R410A	1
27	4518951	4-W valve SHF-4H for R410A	1
28	433229	Valve Cover	1
29	4519606	Right side panel (painting plate)	1
31	236179	2 Poles terminal block	1
33	4514588	5 Poles terminal block	1
34	433228	Back Side Net	1
35	462300052	Condenser Assy./ONG3-9RC R410A(PA103)	1
36	4519614	Painting Top Cover	1
37	433225	Handle	1
38	4526298	Bridge	1
40	4519607	Left Side Panel Painting Plate	1
41	464860054	Painting Insulation Plate Assy/ONG	1
70	452773000	Cond. Fixture	1

14.37 Outdoor Unit ONG3-12 RC R410A B2

No.	Item Code	Item Description	Quantity
1	433218	Front Panel A	1
2	433221	Air Inlet Ring-420	1
3	464600063	Base Plate Painting Assy./ ONG3-12R410A(1
5	455000108	Double patch Capacitor for fan	1
6	433217	Partition Plate	1
7	4519300	Nut M5 L	1
8	455000503	Compressor Capacitor With Screw	1
9	201019	Nut M8	1
10	4524177	3/8 Gas Valve(R410A)	1
11	4526301	High pressure stop valve R410a	1
12	4519251	Axial Fan OD=400	1
14	204107	Cable clip Nylon	1
15	453012700	Electric Panel	1
16	4519692R	Fan Motor (810rpm)	1
17	4527203	Motor Support	1
18	463600035	CapillaryAssy.2.6*1.6*(900900)/ONG3-12RC	1
19	4510677	Nut With Flange M8 -D=24	3
20	391498	Wire assy	1
21	460150005R	CompressorAssy5PS132EAA22Panasonic	1
22	469100003	Insulation Felt/ Compressor	1
24	4516637	Out sensor Black	1
25	461600047	4-Way Valve Assy/ONG3-12RC R410A(5PS132	1
26	4520071	4-W valve coil for R410A	1
27	4518951	4-W valve SHF-4H for R410A	1
28	433229	Valve Cover	1
29	4519606	Right side panel (painting plate)	1
31	236179	2 Poles terminal block	1
33	4514588	5 Poles terminal block	1
34	433228	Back Side Net	1
35	462300003	Condenser Assy.	1
36	4519614	Painting Top Cover	1
37	433225	Handle	1
38	4526298	Bridge	1
40	4519607	Left Side Panel Painting Plate	1
41	464860054	Painting Insulation Plate Assy/ONG	1
70	452813200	coil stopper	1

14.38 Outdoor Unit ONG3-14 RC R410A B1

No.	Item Code	Item Description	Quantity
1	433218	Front Panel A	1
2	433221	Air Inlet Ring-420	1
3	464600001	Base Plate Painting Assy.	1
5	455000108	Double patch Capacitor for fan	1
6	433217	Partition Plate	1
7	4519300	Nut M5 L	1
8	455000505	Compressor Capacitor With Screw	1
9	201019	Nut M8	1
10	4524595	1/2 Gas Valve for ONG R410A	1
11	4526301	High pressure stop valve R410a	1
12	4519251	Axial Fan OD=400	1
14	204107	Cable clip Nylon	1
15	453012700	Electric Panel	1
16	4520171R	Fan Motor (910rpm)	1
17	4527203	Motor Support	1
18	463600041	CapillaryAssy.2.6*1.6*(700800)/ONG3-14R4	1
19	4510677	Nut With Flange M8 -D=24	3
20	391498	Wire assy	1
21	460150011R	CompressorAssy./5KS170EAA21Panasonic/ONG	1
22	4527058	Comp. Jacket	1
24	4516637	Out sensor Black	1
25	461600053	4-Way Valve Assy/ONG3-14RC R410A.	1
26	4520071	4-W valve coil for R410A	1
27	4518952	4-W valve SHF-7H for R410A	1
28	433229	Valve Cover	1
29	4519606	Right side panel (painting plate)	1
31	236179	2 Poles terminal block	1
33	4514588	5 Poles terminal block	1
34	433228	Back Side Net	1
35	462300003	Condenser Assy.	1
36	4519614	Painting Top Cover	1
37	433225	Handle	1
38	4526298	Bridge	1
40	4519607	Left Side Panel Painting Plate	1
41	464860054	Painting Insulation Plate Assy/ONG	1
70	452813200	coil stopper	1

14.39 Outdoor Unit ONG3 17 ST

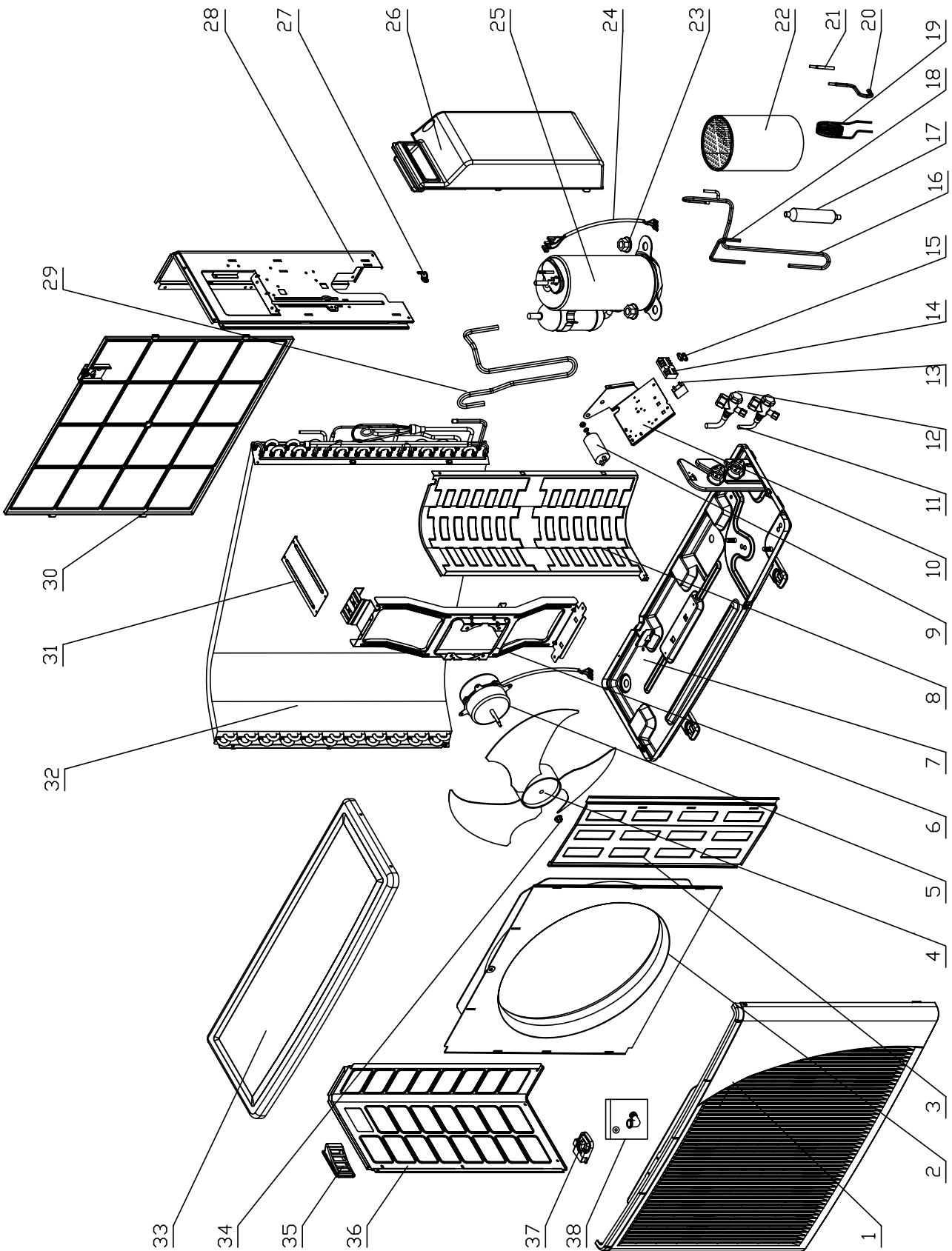

14.40 Outdoor Unit ONG3 17 ST

No.	Part No	Description	Quantity
1	433218	Front panel A	1
2	433221	Air Inlet Ring-420	1
3	433223	Painting Insulation Plate	1
4	4519251	Fan	1
5	4520171	Fan Motor	1
6	4527203	Motor support	1
7	464600001	Base Painting Assy.	1
8	4527202	Partition plate	1
9	455000506	Compressor Capa.30uF	1
10	453013500	Painting Electric Plate	1
11	4524176	Liquid Valve	1
12	4524595	Gas Valve	1
13	455000001	Capacitor 2uF	1
14	4514588	5 Poles Terminal block	1
15	204107	Cable clip Nylon	1
16	463300007	Discharge Pipe 1	1
17	453091000	Muffler	1
18	463300008	Discharge Pipe 2	1
19	463100002	Capillary/3.2X1.9X1400	1
20	463300049	Connect Pipe	1
21	463070000	Transition Pipe/ Capillary	1
22	469270002	Compressor Jacket	1
23	4510677	Nut With Flange M8	3
24	4519987	Wire assy	1
25	460000001	Compressor Assy/PA200X2CS-4KT1	1
26	433229	Valve Cover	1
27	433234	Clamp	1
28	4519606	Right Side Plate	1
29	463300006	Suction Pipe	1
30	433228	Back Side Net	1
31	433216	Bridge	1
32	462300004	Condenser Soldering Assy.	1
33	4519614	Painting Top Cover	1
34	4519300	Fan Nut M5 Left Rotation	1
35	433225	Right Handle	1
36	4519607	Left side panel	1
37	470120001	Rubber Cushion /Base Plate	4
38	453121300	Install Accessory	1

14.41 Outdoor Unit ONG3 17 RC

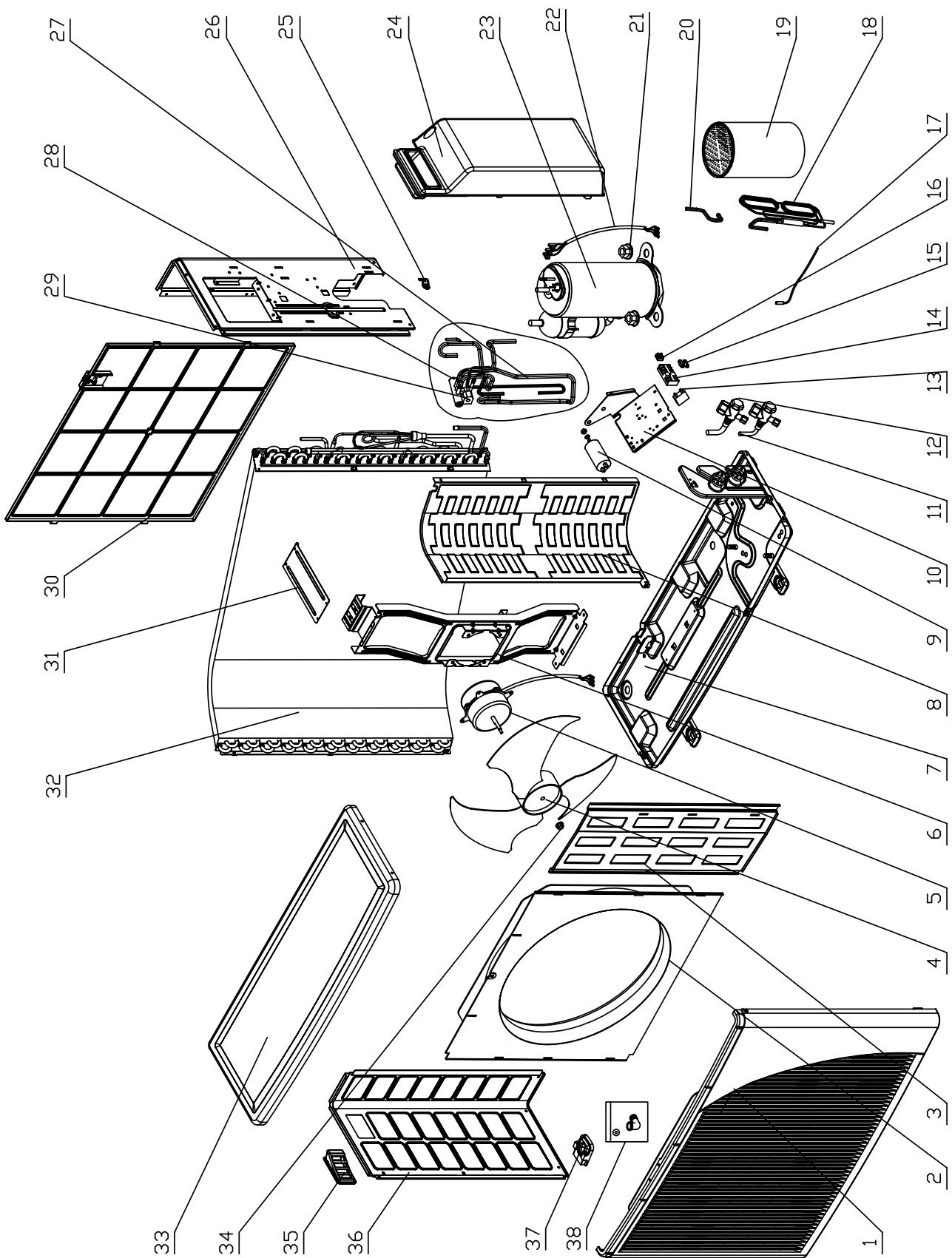

14.42 Outdoor Unit ONG3 17 RC

No.	Part No	Description	Quantity
1	433218	Front panel A	1
2	433221	Air Inlet Ring-420	1
3	433223	Painting Insulation Plate	1
4	4519251	Fan	1
5	4520171	Fan Motor	1
6	4527203	Motor support	1
7	464600001	Base Painting Assy.	1
8	4527202	Partition plate	1
9	455000506	Compressor Capa.30uF	1
10	453013500	Painting Electric Plate	1
11	4524176	Liquid Valve	1
12	4524595	Gas Valve	1
13	455000001	Capacitor 2uF	1
14	4514588	5 Poles Terminal block	1
15	204107	Cable clip Nylon	1
16	236179	2 Poles Terminal block	1
17	4516637	Out sensor Black	1
18	463600000	Capillary Assy.	1
19	469270002	Compressor Jacket	1
20	463230014	2-Way Strainer	1
21	4510677	Nut With Flange M8	3
22	4519987	Wire assy	1
23	460000000	Compressor Assy/PA200X2CS-4KT1	1
24	433229	Valve Cover	1
25	433234	Clamp	1
26	4519606	Right Side Plate	1
27	461600001	4-Way Valve Assy.	1
28	4518952	4-Way Valve SHF-7H for R410A	1
29	4520071	4-Way Valve coil for R410a	1
30	433228	Back Side Net	1
31	433216	Bridge	1
32	462300003	Condenser Soldering Assy.	1
33	4519614	Painting Top Cover	1
34	4519300	Fan Nut M5 Left Rotation	1
35	433225	Right Handle	1
36	4519607	Left side panel	1
37	470120001	Rubber Cushion /Base Plate	4
38	453121300	Install Accessory	1

14.43 Outdoor Unit ONG3-17 RC R410A A2

No.	Item Code	Item Description	Quantity
1	433218	Front Panel A	1
2	433221	Air Inlet Ring-420	1
3	464860054	Painting Insulation Plate Assy/ONG	1
4	4519251	Axial Fan OD=400	1
5	4520171R	Fan Motor (910rpm)	1
6	4527203	Motor Support	1
7	464600001	Base Plate Painting Assy.	1
8	4527202	Partition Plate	1
9	455000506	Compressor Capacitor With Screw	1
10	453012700	Electric Panel	1
11	4524176	1/4 Liquid Valve(R410A)	1
12	4524595	1/2 Gas Valve for ONG R410A	1
13	455000001	single patch Capacitor for fan	1
14	4514588	5 Poles terminal block	1
15	204107	Cable clip Nylon	1
16	236179	2 Poles terminal block	1
17	4516637	Out sensor Black	1
18	463600000	Capillary Assy	1
19	469270002	Insulation Rub+Felt/Compress	1
20	463230014	Way Strainer	1
21	4510677	Nut With Flange M8 -D=24	3
22	4519987	Wire assy	1
23	460000000	Compressor Assy./ GMCC PA200X	1
24	433229	Valve Cover	1
26	4519606	Right side panel (painting plate)	1
27	461600001	4Way Valve Assy.	1
28	4518952	4-W valve SHF-7H for R410A	1
29	4520071	4-W valve coil for R410A	1
30	433228	Back Side Net	1
31	4526298	Bridge	1
32	462300003	Condenser Assy.	1
33	4519614	Painting Top Cover	1
34	4519300	Nut M5 L	1
35	433225	Handle	1
36	4519607	Left Side Panel Painting Plate	1
37	470120001	Rubber Cushion /Base Plate	4
38	453121300	Install. Accessory	1

14.44 Outdoor Unit ONG3 17 ST with easy connection kit

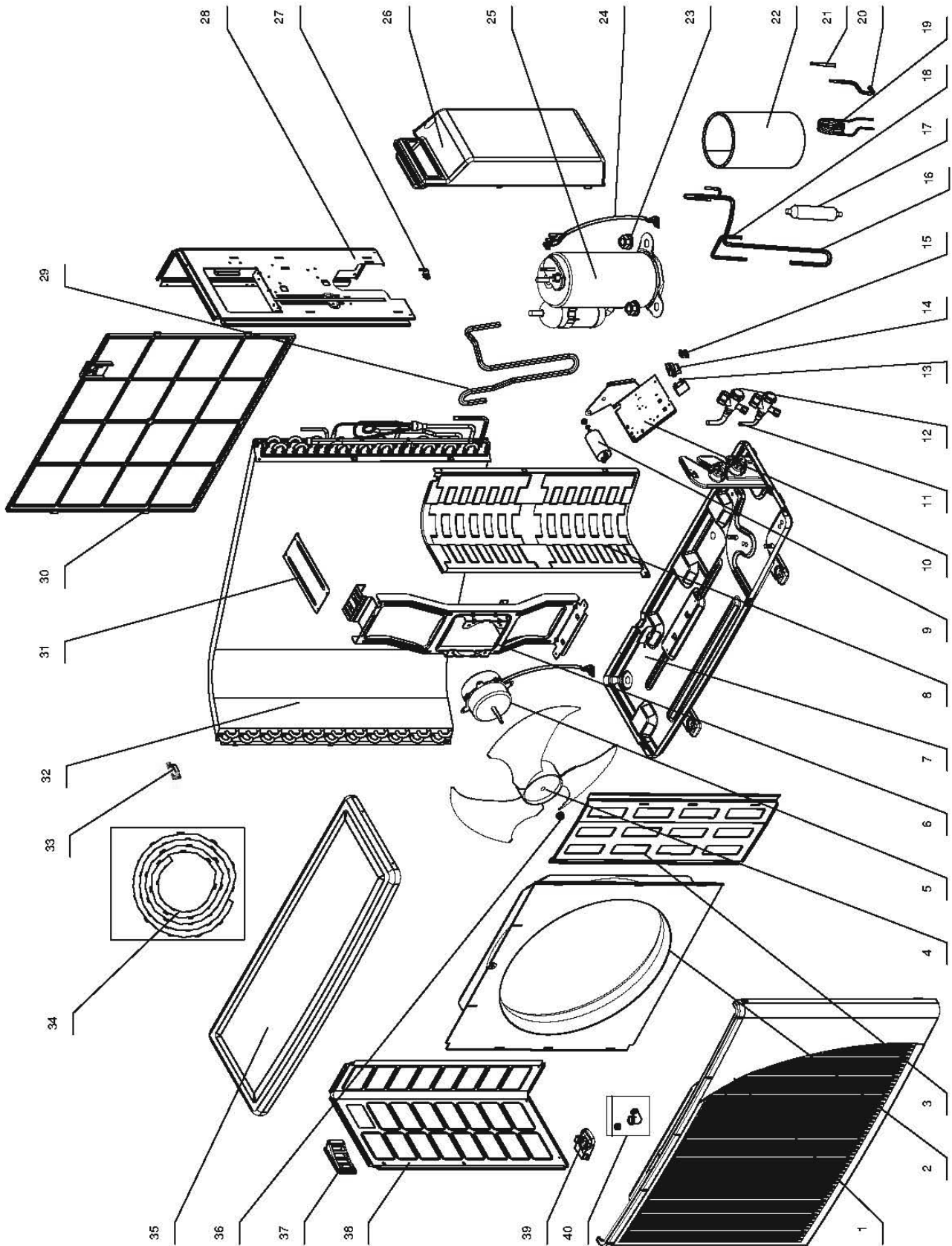

14.45 Outdoor Unit ONG3 17 ST with easy connection kit

No.	Part No	Description	Quantity
1	433218	Front panel A	1
2	433221	Air Inlet Ring-420	1
3	433223	Painting Insulation Plate	1
4	4519251	Fan	1
5	4520171	Fan Motor	1
6	4527203	Motor support	1
7	464600001	Base Painting Assy.	1
8	4527202	Partition plate	1
9	455000506	Compressor Capa.30uF	1
10	453013500	Painting Electric Plate	1
11	4524176	Liquid Valve	1
12	4524595	Gas Valve	1
13	455000001	Capacitor 2uF	1
14	453080600	Terminal Socket/ Alpha Controller	1
15	204107	Cable clip Nylon	1
16	463300007	Discharge Pipe 1	1
17	453091000	Muffler	1
18	463300008	Discharge Pipe 2	1
19	463100002	Capillary/3.2X1.9X1400	1
20	463300049	Connect Pipe	1
21	463070000	Transition Pipe/ Capillary	1
22	469270002	Compressor Jacket	1
23	4510677	Nut With Flange M8	3
24	4519987	Wire assy	1
25	460000001	Compressor Assy/PA200X2CS-4KT1	1
26	433229	Valve Cover	1
27	433234	Clamp	1
28	4519606	Right Side Plate	1
29	463300006	Suction Pipe	1
30	433228	Back Side Net	1
31	433216	Bridge	1
32	462300004	Condenser Soldering Assy.	1
33	453054400	Fixing plate/Terminal plate	1
34		Connect Pipe Assy./1/4'+1/2'/Alpha17ST	1
35	4519614	Painting Top Cover	1
36	4519300	Fan Nut M5 Left Rotation	1
37	433225	Right Handle	1
38	4519607	Left side panel	1
39	470120001	Rubber Cushion /Base Plate	4
40	453121300	Install Accessory	1

14.46 Outdoor Unit ONG3 17 RC with easy connection kit

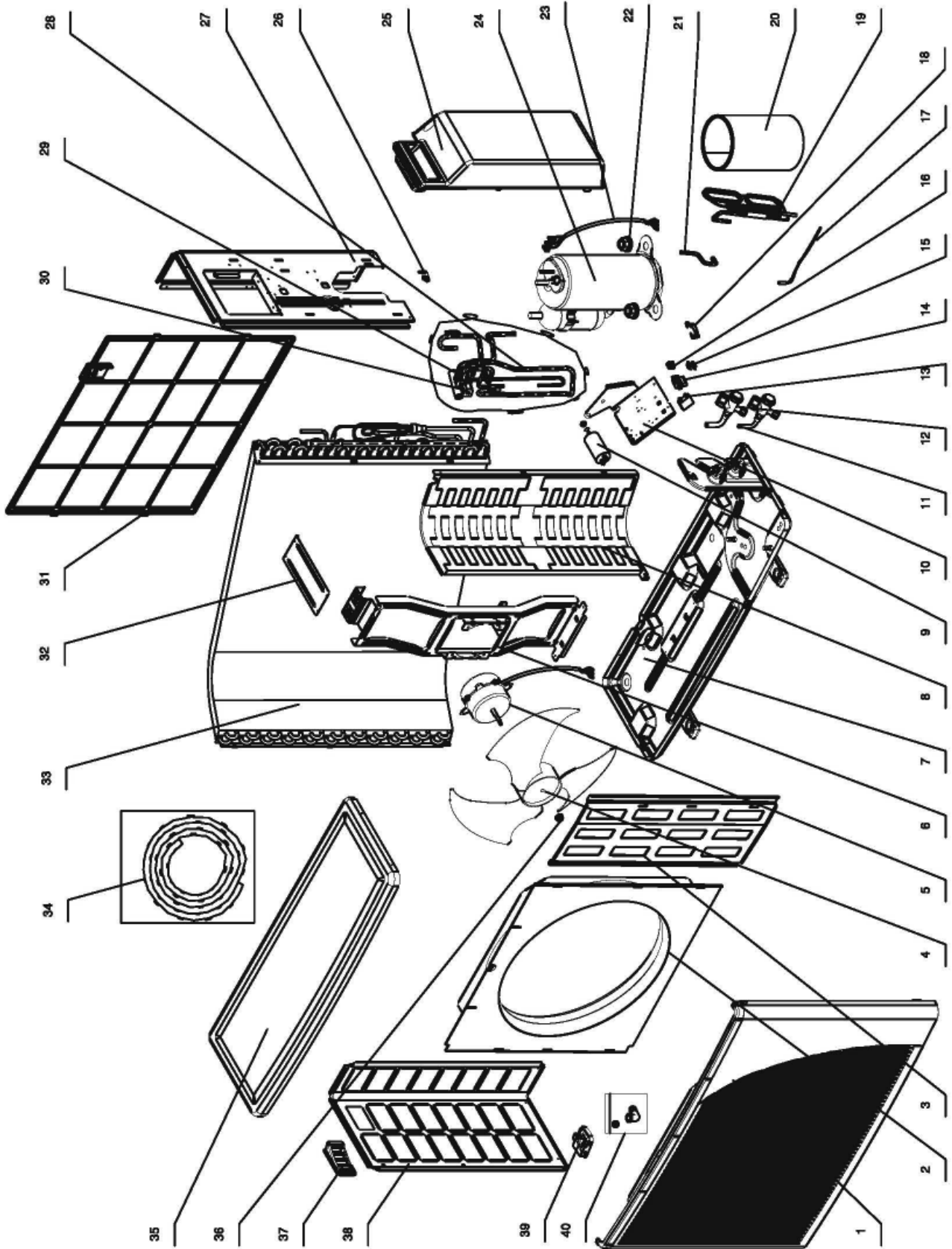

14.47 Outdoor Unit ONG3 17 RC with easy connection kit

No.	Part No	Description	Quantity
1	433218	Front panel A	1
2	433221	Air Inlet Ring-420	1
3	433223	Painting Insulation Plate	1
4	4519251	Fan	1
5	4520171	Fan Motor	1
6	4527203	Motor support	1
7	464600001	Base Painting Assy.	1
8	4527202	Partition plate	1
9	455000506	Compressor Capa.30uF	1
10	453013500	Painting Electric Plate	1
11	4524176	Liquid Valve	1
12	4524595	Gas Valve	1
13	455000001	Capacitor 2uF	1
14	453080600	Terminal Socket/ Alpha Controller	1
15	204107	Cable clip Nylon	1
16	236179	2 Poles Terminal block	1
17	4516637	Out sensor Black	1
18	453054400	Fixing plate/Terminal plate	1
19	463600000	Capillary Assy.	1
20	469270002	Compressor Jacket	1
21	463230014	2-Way Strainer	1
22	4510677	Nut With Flange M8	3
23	4519987	Wire assy	1
24	460000000	Compressor Assy/PA200X2CS-4KT1	1
25	433229	Valve Cover	1
26	433234	Clamp	1
27	4519606	Right Side Plate	1
28	461600001	4-Way Valve Assy.	1
29	4518952	4-Way Valve SHF-7H for R410A	1
30	453118500	4-Way Valve coil for R410a	1
31	433228	Back Side Net	1
32	433216	Bridge	1
33	462300003	Condenser Soldering Assy.	1
34		Connect Pipe Assy./1/4'+1/2'/Alpha17RC	1
35	4519614	Painting Top Cover	1
36	4519300	Fan Nut M5 Left Rotation	1
37	433225	Right Handle	1
38	4519607	Left side panel	1
39	470120001	Rubber Cushion /Base Plate	4
40	453121300	Install Accessory	1

14.49 Outdoor Unit OU7-24C

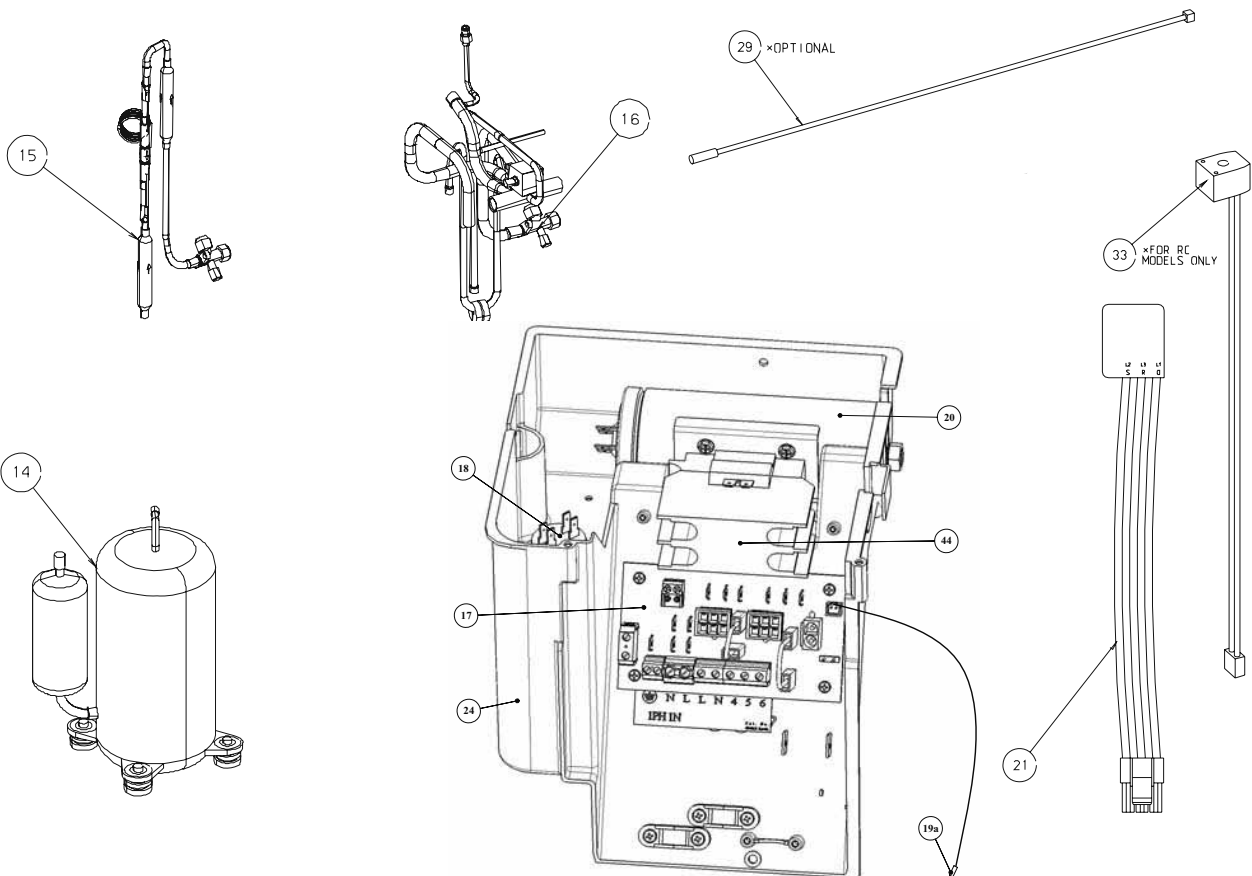
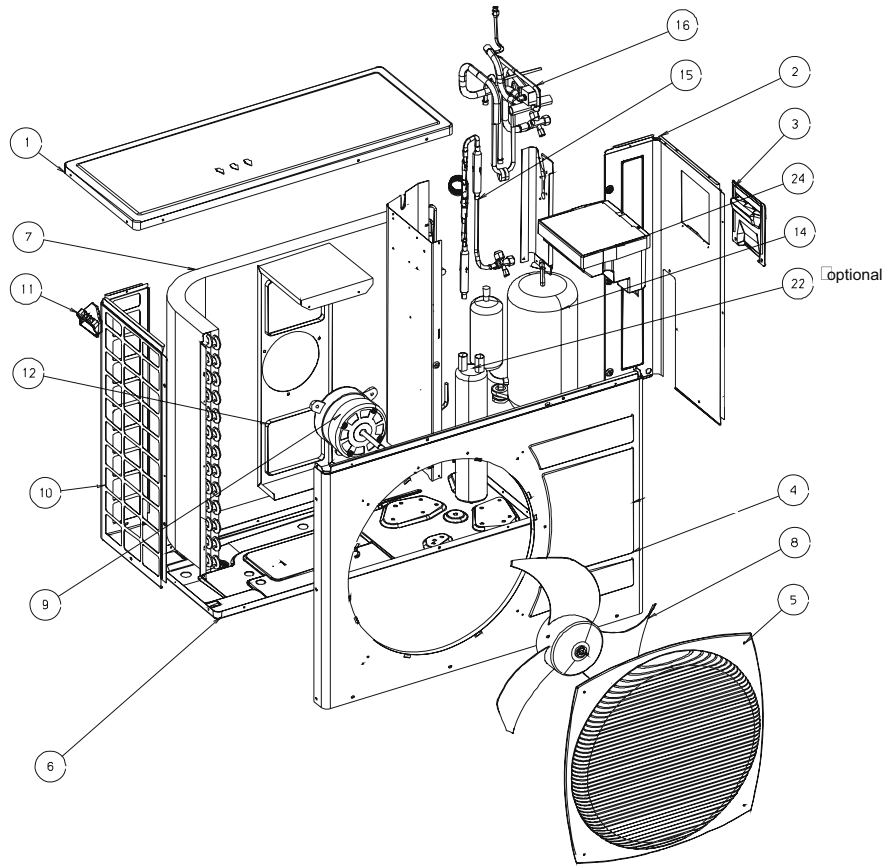

14.50 Outdoor Unit OU7-24C

No.	Item Code	Item Description	Quantity
1	465020098	Front Plate/Delta 18&24 Fagor	1
2	452919800	Filter	2
3	4518113	AIR FILTER ASSY	1
4	465720204	Silk-Screen Front Frame Assy./Delta 18-2	1
5	452919600	Screw cover	3
6	462350084	Evaporator Assy./WNG24 R410A	1
7	452917300	Air outlet	1
8	465210009	Drain Pipe for Israel /WNG18/24/30	1
9	452917500	Horizontal flap A	1
9	452917600	Horizontal flap B	1
10	452930700	A Vertical flap A	12
10	452918200	B Vertical flap B	2
11	4518662	Bearing assy fan	1
12	453024900	Impeller fan	1
13	453053800	Base assy./WNG18	1
14	452920100	Mount bracket/WNG-18 £"20£©	1
15	452919400	Joint/Unit housing	1
16	453134300R	Resin Motor 26W 1300/1200/ 1100 /WNG24 L	1
17	452918800	Cover/motor	1
18	453050300	B STEP MOTOR B	1
20	4519147	Power Cord Clip	1
20	452919200	Tie/connection Wire	1
21	467300197R	Display Board/Delta 18 F	1
22	452919100	Support/sensor	1
22	4516263	SENSOR BASE	1
23	467300201R	Controller/Delta F 18 S/W:10V14	1
24	438082	Thermistor Indoor	1
25	467400025	(650mm) Indoor Air Inlet Temperature S	1
26	452919500	Cover/terminal	1
28	4520416	Defrost cable EXPORT UNITS£©	1
29	438600R	Remote controller RC3-RC 973-600-00	1
30	4518651	Cover Side Motor	1
31	453057900	Gear BOX ASSY	1
34	452918700	Support/horizontal louver	2
36	4518657	TUBE LOCK	1

APPENDIX A

INSTALLATION AND OPERATION MANUAL

- ▶ **INSTALLATION AND OPERATION MANUAL ALPHA 7, 9, 12, 17**