

Airwell

Service Manual

YAZ318

Indoor Units	Outdoor Units
AWSI-PNXA009/012-N11	AWAU-YAZ318-H11
CK09/12 DCI	
SX09/12 DCI	
DLF09/12 DCI	
XLF09/12 DCI	
AWSI-HAD007/009/012-N11	
AWSI-HFD007/009/012-N11	
AWSI-XLD009/012-N11	



REFRIGERANT

R410A

HEAT PUMP

SM YAZ318 1-A.1 GB

FEBRUARY - 2011

Version:1

LIST OF EFFECTIVE PAGES

Note: Changes in the pages are indicated by a "Revision#" in the footer of each effected page (when none indicates no changes in the relevant page). All pages in the following list represent effected/ non-effected pages divided by chapters.

Dates of issue for original and changed pages are:

Original ... 01... 17 February, 11

Total number of pages in this publication is **96** consisting of the following:

Page No.	Revision No. #	Page No.	Revision No. #	Page No.	Revision No. #
----------	----------------	----------	----------------	----------	----------------

* Zero in this column indicates an original page.

Table of Contents

1. INTRODUCTION 1-1

2. PRODUCT DATA SHEET..... 2-1

3. RATING CONDITIONS 3-1

4. OUTLINE DIMENSIONS 4-1

5. PERFORMANCE DATA 5-1

6. OPERATING CURVES 6-1

7. ELECTRICAL DATA..... 7-1

8. WIRING DIAGRAM 8-1

9. REFRIGERATION DIAGRAM 9-1

10. TUBING CONNECTIONS 10-1

11. CONTROL SYSTEM..... 11-1

12. TROUBLESHOOTING 12-1

13. EXPLODED VIEW AND SPARE PART LIST 13-1

.14 APPENDIX A 14-1

INTRODUCTION

1. INTRODUCTION

1.1 General

The YAZ318 is a multi-tubing system with three connected indoor units. The multi-split inverter is a high-level technology product for residential and commercial application offering comfort, low noise operation and energy saving.

1.2 Main Features

1.2.1 High Technology

- Sine wave form for compressor driving.
- DC-BL-SL (Sensor less) Inverter Compressor drive.
- High-speed MCU calculation for accurate Sine wave control.
- Smart PFC control.
- Fuzzy Logic Control

1.2.2 System Features

- R410A
- High COP ("A" class energy rating)
- Low noise levels
- IAQ (Indoor Air Quality) features (LEX/PNX series)
- Lego concept - Products line of wall mounted, floor/ceiling, cassette, ducted with capacity models of 2.2, 2.5 and 3.5 kW.
- Networking connectivity.
- Pre-charged system.
- Ready for Base heater connection and logic.
- Cooling operation at outdoor temperature down to +10°C.
- Heating operation at outdoor temperature down to -15°C.
- HMI Display Board (Human-Machine Interface) – 3x7-segment display shows both indoor and outdoor diagnostics and setting up features.
- Monitoring software(PC port).
- EEV (Electronic Expansion Valve) for each indoor unit.

1.3 Tubing Connections







Flare type interconnecting tubing to be produced on site.

For further details, please refer to APPENDIX A on this manual, and to the relevant indoor service Manual.

1.4 Inbox Documentation

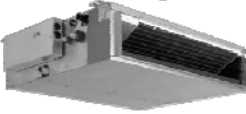
Each indoor unit is supplied with its own installation and operation manuals.

1.5 Matching Table

INDOOR UNITS	
	AWSI-PNXA009-N11 AWSI-PNXA012-N11
	CK09 DCI CK12 DCI
	SX09 DCI SX12 DCI
	DLF09 DCI DLF12 DCI
	XLF09 DCI / AWSI-XLD009-N11 XLF12 DCI / AWSI-XLD012-N11
	AWSI-HAD007-N11 AWSI-HAD009-N11 AWSI-HAD012-N11
	AWSI-HFD007-N11 AWSI-HFD009-N11 AWSI-HFD012-N11

1.6 Indoor Unit combinations

YAZ318			
Unit A	Unit B	Unit D	Code Sum
22	22	22	3
22	22	25	3
22	22	35	3.5
22	25	25	3
22	25	35	3.5
25	25	25	3
25	25	35	3.5

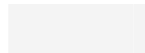
 Nominal Indoor Units Combination

2. PRODUCT DATA SHEET

2.1 Outdoor YAZ318 Specifications

Model Indoor Unit					
Model Outdoor Unit		YAZ3 018 R410A			
Installation Method of Pipe		Flared			
Characteristics		Units	Cooling Heating		
Capacity (4)		Btu/hr	17740(3412~22180) 22520(3412~24910)		
		kW	5.2(1.0~6.5) 6.6(1.0~7.3)		
Power input (4)		kW	1.46(0.45~2.15) 1.71(0.45~1.9)		
EER (Cooling) or COP(Heating) (4)		W/W	3.56 3.86		
Energy efficiency class			A A		
Power supply		V	220-240		
		Ph	1		
		Hz	50/60		
Rated current		A	6.5 7.6		
Power factor			0.97 0.97		
Prated (IDU)		W	See DCI Single		
Prated (IDU+ODU)		W	2800		
Starting current		A	10.5		
Circuit breaker rating		A	20		
INDOOR			See DCI Single		
OUTDOOR	Refrigerant control		Electronical expansion valve		
	Compressor type, model		Two Rotary DC INV GMCC DA150S1C-20FZ		
	Fan type & quantity		Propeller x 1		
	Fan speeds	H	RPM	830	
	Air flow	H	m ³ /hr	2860	
	Sound power level	H	dB(A)	67	
	Sound pressure level(3)	H	dB(A)	56	
	Dimensions	WxHxD	mm	846x690x302	
	Net Weight		kg	48	
	Package dimensions	WxHxD	mm	990x770x430	
	Packaged weight		kg	52	
	Units per pallet		Units	9	
	Stacking height		units	3	
	Refrigerant type			R410A	
	Standard charge		kg(15m)	1.6	
Additional charge			Length ≤ 20m: +0g; 20m < Length ≤ 30m: +300g		
TUBING	Connection method between the indoor and outdoor units	Liquid line	In.(mm)	3x1/4"(6.35)	
		Suction line	In.(mm)	3x3/8"(9.53)	
		Max tubing length for single IDU to ODU	m		Max.25m
		Height difference between indoor units	m		Max.5m
		Height difference between indoor & outdoor	m		Max.15m
		Max total tubing length	m		Max.30m
Operation control type			Remote control		
Heating elements (Option)		kW			
Others					

- (1)Airflow in ducted units; at nominal external static pressure.
- (2)Sound power in ducted units is measured at air discharge.
- (3)Sound pressure level measured at 1-meter distance from unit.
- (4)Rating conditions in accordance to ISO 5151 and ISO 13253 (for ducted units).
- (5)Nominal capacity is measured with the combination of 3x HAD 25 DCI and 5m tubing each unit.
Maximum capacity is measured with the combination of 2xHAD 25 DCI + HAD 35 DCI and 5m tubing each unit.
Minimum capacity is measured with HAD 25 DCI and 5m tubing.

2.2 Indoor Units Data

2.2.1 AWSI-PNXA009-N11

Model Indoor Unit			AWSI-PNXA009-N11	
Installation Method of Pipe			Flared	
Power supply		V/Ph/Hz	220-230V/1 Ph/50 Hz	
INDOOR	Fan type & quantity		Crossflow x 1	
	Fan speeds	H/M/L RPM	1050/900/800	
	Air flow (1)	H/M/L m3/hr	530/430/330	
	External static pressure	Min Pa	0	
	Sound power level (2)	H/M/L dB(A)	51/ - /39	
	Sound pressure level(3)	H/M/L dB(A)	39/ - /26	
	Moisture removal		l/hr	1
	Condensate drain tube I.D		mm	16
	Dimensions	WxHxD mm	810x285x210	
	Net Weight		kg	11.5
	Package dimensions	WxHxD mm	870x356x282	
	Packaged weight		kg	14
	Units per pallet		units	28
	Stacking height		units	7 levels

2.2.2 AWSI-PNXA012-N11

Model Indoor Unit			AWSI-PNXA012-N11	
Installation Method of Pipe			Flared	
Power supply		V/Ph/Hz	220-230V/1 Ph/50 Hz	
INDOOR	Fan type & quantity		Crossflow x 1	
	Fan speeds	H/M/L RPM	1100/950/800	
	Air flow (1)	H/M/L m3/hr	550/450/350	
	External static pressure	Min Pa	0	
	Sound power level (2)	H/M/L dB(A)	52/ - /39	
	Sound pressure level(3)	H/M/L dB(A)	40/ - /26	
	Moisture removal		l/hr	1.5
	Condensate drain tube I.D		mm	16
	Dimensions	WxHxD mm	810x285x210	
	Net Weight		kg	11.5
	Package dimensions	WxHxD mm	870x356x282	
	Packaged weight		kg	14
	Units per pallet		units	28
	Stacking height		units	7 levels

2.2.3 CK09 DCI

Model Indoor Unit			CK09 DCI		
Installation Method of Pipe			Flared		
Power supply		V/Ph/Hz	220-230V/1 Ph/50 Hz		
INDOOR	Fan type & quantity		Centrifugal x 1		
	Fan speeds	H/M/L	RPM	550/500/450 600/520/450	
	Air flow (1)	H/M/L	m3/hr	420/370/320 470/390/320	
	External static pressure	Min	Pa	0	
	Sound power level (2)	H/M/L	dB(A)	49 49	
	Sound pressure level(3)	H/M/L	dB(A)	32/30/28 34/31/28	
	Moisture removal		l/hr	0.7	
	Condensate drain tube I.D		mm	20	
	Dimensions	WxHxD	mm	575X575X219(625X625X40/725X725X40)	
	Net Weight		kg	12.9(2.2/2.7)	
	Package dimensions	WxHxD	mm	681X681X297(700X700X103/800X800X103)	
	Packaged weight		kg	16.2(3.4/4.2)	
	Units per pallet		units	12	
Stacking height		units	6 levels		

2.2.4 CK12 DCI

Model Indoor Unit			CK12 DCI		
Installation Method of Pipe			Flared		
Power supply		V/Ph/Hz	220-230V/1 Ph/50 Hz		
INDOOR	Fan type & quantity		Centrifugal x 1		
	Fan speeds	H/M/L	RPM	600/520/450 650/550/450	
	Air flow (1)	H/M/L	m3/hr	470/390/320 510/420//320	
	External static pressure	Min	Pa	0	
	Sound power level (2)	H/M/L	dB(A)	51 51	
	Sound pressure level(3)	H/M/L	dB(A)	34/31/28 36/32/28	
	Moisture removal		l/hr	1.5	
	Condensate drain tube I.D		mm	20	
	Dimensions	WxHxD	mm	575X575X219(625X625X40/725X725X40)	
	Net Weight		kg	12.9(2.2/2.7)	
	Package dimensions	WxHxD	mm	681X681X297(700X700X103/800X800X103)	
	Packaged weight		kg	16.2(3.4/4.2)	
	Units per pallet		units	12	
Stacking height		units	6 levels		

2.2.5 SX09 DCI

Model Indoor Unit				SX09 DCI	
Installation Method of Pipe				Flared	
Power supply			V/Ph/Hz	220-240/1/50	
INDOOR	Fan type & quantity			Centrifugal x 2	
	Fan speeds	H/M/L	RPM	760/670/500	
	Air flow (1)	H/M/L	m3/hr	400/350/300	
	External static pressure	Min	Pa	0	
	Sound power level (2)	H/M/L	dB(A)	54/49/41	
	Sound pressure level(3)	H/M/L	dB(A)	42/37/29	
	Moisture removal			l/hr	1
	Condensate drain tube I.D			mm	16
	Dimensions	WxHxD	mm	820x630x190	
	Net Weight			kg	21
	Package dimensions	WxHxD	mm	920x726x273	
	Package weight		kg	25	
	Units per pallet			units	14units per pallet
	Units stacking			units	7 levels

2.2.6 SX12 DCI

Model Indoor Unit				SX12 DCI	
Installation Method of Pipe				Flared	
Power supply			V/Ph/Hz	220-240/1/50	
INDOOR	Fan type & quantity			Centrifugal x 2	
	Fan speeds	H/M/L	RPM	830/760/500	
	Air flow (1)	H/M/L	m3/hr	450/400/300	
	External static pressure	Min	Pa	0	
	Sound power level (2)	H/M/L	dB(A)	56/53/41	
	Sound pressure level(3)	H/M/L	dB(A)	45/41/30	
	Moisture removal			l/hr	1.5
	Condensate drain tube I.D			mm	16
	Dimensions	WxHxD	mm	820x630x190	
	Net Weight			kg	22
	Package dimensions	WxHxD	mm	920x726x273	
	Package weight		kg	26	
	Units per pallet			units	14units per pallet
	Units stacking			units	7 levels

2.2.7 DLF09 DCI

Model Indoor Unit			DLF09 DCI	
Installation Method of Pipe			DUCTED	
Power supply		V/Ph/Hz	220-240/1/50	
INDOOR	Fan type & quantity		Centrifugal x 2	
	Fan speeds	H/M/L RPM	920/810/740	
	Air flow (1)	H/M/L m3/hr	620/560/490	
	External static pressure	Min -Max Pa	0-30	
	Sound power level (2)	H/M/L dB(A)	50/47/44	
	Sound pressure level(3)	H/M/L dB(A)	29/26/23	
	Moisture removal		l/hr	0.5
	Condensate drain tube I.D		mm	19
	Dimensions	WxHxD mm	750x630x200	
	Net Weight		kg	20
	Package dimensions	WxHxD mm	885x695x226	
	Package weight	kg	23	
	Units per pallet		units	14units per pallet
	Units stacking		units	7 levels

2.2.8 DLF12 DCI

Model Indoor Unit			DLF12 DCI	
Installation Method of Pipe			DUCTED	
Power supply		V/Ph/Hz	220-240/1/50	
INDOOR	Fan type & quantity		Centrifugal x 2	
	Fan speeds	H/M/L RPM	980/860/730	
	Air flow (1)	H/M/L m3/hr	650/580/490	
	External static pressure	Min-Max Pa	0-30	
	Sound power level (2)	H/M/L dB(A)	53/49/45	
	Sound pressure level(3)	H/M/L dB(A)	31/27/24	
	Moisture removal		l/hr	1.0
	Condensate drain tube I.D		mm	19
	Dimensions	WxHxD mm	750x630x200	
	Net Weight		kg	20
	Package dimensions	WxHxD mm	885x695x226	
	Package weight	kg	23	
	Units per pallet		units	14units per pallet
	Units stacking		units	7 levels

2.2.9 XLF09 DCI / AWSI-XLD009-N11

Model Indoor Unit			XLF09 DCI/AWSI-XLD009-N11	
Installation Method of Pipe			Flared	
Power supply		V/Ph/Hz	220-240/1/50	
INDOOR	Fan type & quantity		Helicoid x 1	
	Fan speeds	H/M/L RPM	520/490/450	
	Air flow (1)	H/M/L m3/hr	390/370/330	
	External static pressure	Min Pa	0	
	Sound power level (2)	H/M/L dB(A)	55	
	Sound pressure level(3)	H/M/L dB(A)	38/35/32	
	Moisture removal		l/hr	1
	Condensate drain tube I.D		mm	16
	Dimensions	WxHxD	mm	570x570x160
	Net Weight		kg	13.5
	Package dimensions	WxHxD	mm	700x700x255
	Packaged weight		kg	15.5
	Units per pallet		units	16
	Stacking height		units	8levels

2.2.10 XLF12 DCI / AWSI-XLD012-N11

Model Indoor Unit			XLF12 DCI/AWSI-XLD012-N11	
Installation Method of Pipe			Flared	
Power supply		V/Ph/Hz	220-240/1/50	
INDOOR	Fan type & quantity		Helicoid x 1	
	Fan speeds	H/M/L RPM	540/510/450	
	Air flow (1)	H/M/L m3/hr	400/370/310	
	External static pressure	Min Pa	0	
	Sound power level (2)	H/M/L dB(A)	56	
	Sound pressure level(3)	H/M/L dB(A)	39/36/33	
	Moisture removal		l/hr	1.6
	Condensate drain tube I.D		mm	16
	Dimensions	WxHxD	mm	570x570x160
	Net Weight		kg	14
	Package dimensions	WxHxD	mm	700x700x255
	Packaged weight		kg	16
	Units per pallet		units	16
	Stacking height		units	8evels

AWSI-HAD007-N11

2.2.11 AWSI-HAD007-N11

Model Indoor Unit			AWSI-HAD007-N11	
Installation Method of Pipe			Flared	
Power supply		V/Ph/Hz	220-240/1/50	
INDOOR	Fan type & quantity		Crossflow x 1	
	Fan speeds	H/M/L RPM	1050/900/750	
	Air flow (1)	H/M/L m3/hr	350/300/250	
	External static pressure	Min Pa	0	
	Sound power level (2)		53	
	Sound pressure level(3)	H/M/L dB(A)	37/32/27	
	Moisture removal		l/hr	0.9
	Condensate drain tube I.D		mm	16
	Dimensions	WxHxD mm	680 x250 X188	
	Net Weight		kg	7
	Package dimensions	WxHxD mm	740x310x248	
	Packaged weight		kg	10
	Units per pallet		units	32
	Stacking height		units	8

2.2.12 AWSI-HAD009-N11

Model Indoor Unit			AWSI-HAD009-N11	
Installation Method of Pipe			Flared	
Power supply		V/Ph/Hz	220-240/1/50	
INDOOR	Fan type & quantity		Crossflow x 1	
	Fan speeds	H/M/L RPM	1150/1000/800	
	Air flow (1)	H/M/L m3/hr	420/350/270	
	External static pressure	Min Pa	0	
	Sound power level (2)	H/M/L dB(A)	54	
	Sound pressure level(3)	H/M/L dB(A)	40/35/29	
	Moisture removal		l/hr	1.0
	Condensate drain tube I.D		mm	16
	Dimensions	WxHxD mm	680 x250 X188	
	Net Weight		kg	7
	Package dimensions	WxHxD mm	740x310x248	
	Packaged weight		kg	10
	Units per pallet		units	32
	Stacking height		units	8

2.2.13 AWSI-HAD012-N11

Model Indoor Unit			AWSI-HAD012-N11	
Installation Method of Pipe			Flared	
Power supply		V/Ph/Hz	220-240/1/50	
INDOOR	Fan type & quantity		Crossflow x 1	
	Fan speeds	H/M/L RPM	1150/950/750	
	Air flow (1)	H/M/L m3/hr	550/450/350	
	External static pressure	Min Pa	0	
	Sound power level (2)	H/M/L dB(A)	56	
	Sound pressure level(3)	H/M/L dB(A)	40/34/28	
	Moisture removal		l/hr	1.5
	Condenstate drain tube I.D		mm	16
	Dimensions	WxHxD mm	840x250x188	
	Net Weight		kg	8
	Package dimensions	WxHxD mm	900x310x248	
	Packaged weight		kg	11
	Units per pallet		units	32
	Stacking height		units	8

2.2.14 AWSI-HFD007-N11

Model Indoor Unit			AWSI-HFD007-N11	
Installation Method of Pipe			Flared	
Power supply		V/Ph/Hz	220-240/1/50	
INDOOR	Fan type & quantity		Crossflow x 1	
	Fan speeds	H/M/L RPM	1100/950/800	
	Air flow (1)	H/M/L m3/hr	350/300/250	
	External static pressure	Min Pa	0	
	Sound power level (2)	H/M/L dB(A)	48/44/41	
	Sound pressure level(3)	H/M/L dB(A)	36/31/28	
	Moisture removal		l/hr	0.9
	Condenstate drain tube I.D		mm	16
	Dimensions	WxHxD mm	680x250x185	
	Net Weight		kg	7
	Package dimensions	WxHxD mm	740x320x265	
	Packaged weight		kg	10
	Units per pallet		units	36 units per pallet
	Stacking height		units	9 levels

2.2.15 AWSI-HFD009-N11

Model Indoor Unit			AWSI-HFD009-N11	
Installation Method of Pipe			Flared	
Power supply		V/Ph/Hz	220-240/1/50	
INDOOR	Fan type & quantity		Crossflow x 1	
	Fan speeds	H/M/L RPM	1200/1050/850	
	Air flow (1)	H/M/L m3/hr	420/350/270	
	External static pressure	Min Pa	0	
	Sound power level (2)	H/M/L dB(A)	54/50/47	
	Sound pressure level(3)	H/M/L dB(A)	39/35/32	
	Moisture removal		l/hr	1
	Condensate drain tube I.D		mm	16
	Dimensions	WxHxD mm	680x250x185	
	Net Weight		kg	7
	Package dimensions	WxHxD mm	740x320x265	
	Packaged weight		kg	10
	Units per pallet		units	36 units per pallet
	Stacking height		units	9 levels

2.2.16 AWSI-HFD012-N11

Model Indoor Unit			AWSI-HFD012-N11	
Installation Method of Pipe			Flared	
Power supply		V/Ph/Hz	220-240/1/50	
INDOOR	Fan type & quantity		Crossflow x 1	
	Fan speeds	H/M/L RPM	1200/1000/850	
	Air flow (1)	H/M/L m3/hr	550/450/350	
	External static pressure	Min Pa	0	
	Sound power level (2)	H/M/L dB(A)	56/50/46	
	Sound pressure level(3)	H/M/L dB(A)	39/33/29	
	Moisture removal		l/hr	1.5
	Condensate drain tube I.D		mm	16
	Dimensions	WxHxD mm	840x250x185	
	Net Weight		kg	8
	Package dimensions	WxHxD mm	930x320x265	
	Packaged weight		kg	11
	Units per pallet		units	36 units per pallet
	Stacking height		units	9 levels

3. RATING CONDITIONS

Rating conditions in accordance with ISO 5151 and ISO 13253 (for ducted units).

Cooling:

Indoor: 27°C DB 19°C WB

Outdoor: 35°C DB

Heating:

Indoor: 20°C DB

Outdoor: 7°C DB 6°C WB

3.1 Operating Limits

		Indoor	Outdoor
Cooling	Upper limit	32°C DB 23°C WB	46°C DB
	Lower limit	21°C DB 15°C WB	10°C DB
Heating	Upper limit	27°C DB	24°C DB 18°C WB
	Lower limit	10°C DB	-15°C DB -16°C WB
Voltage	1PH	198 – 264 VAC	
	3PH	N/A	

4. OUTLINE DIMENSIONS

4.1 Indoor Unit : PNXA009/012

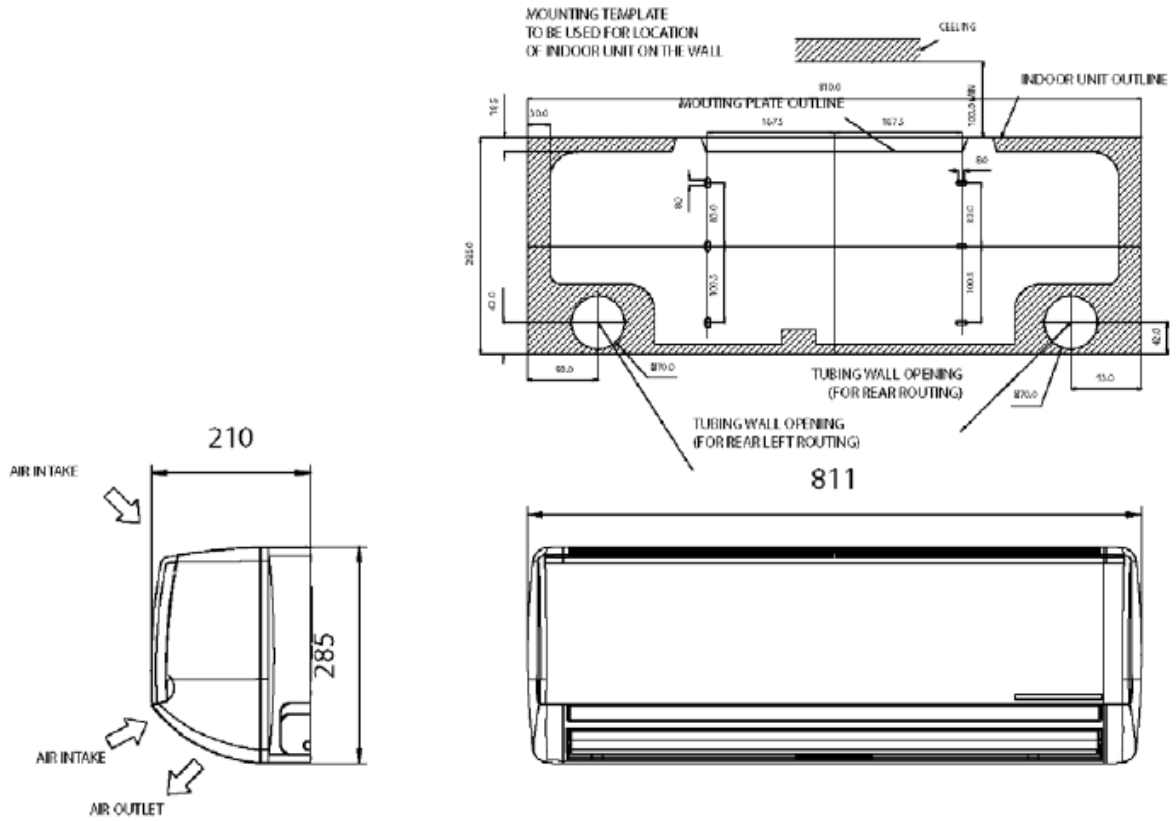

4.2 Indoor Unit : CK09/12 DCI

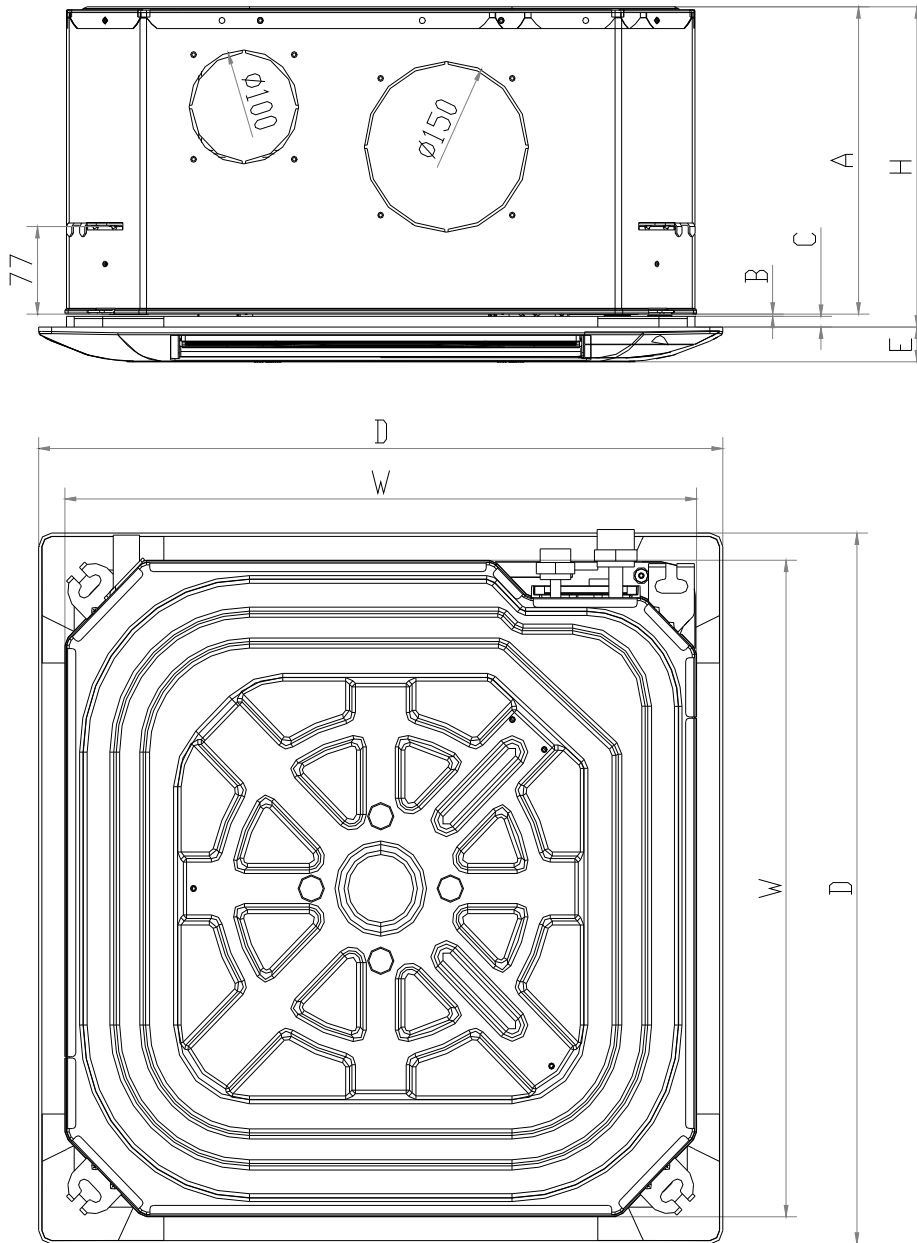

Unit Model	Main unit A	Insulation B	Front Step C	Front width D	Front height E	Effective Height H
25/35	219	2	9	625/725	40	230

4.3 Indoor Unit: SX09/12 DCI

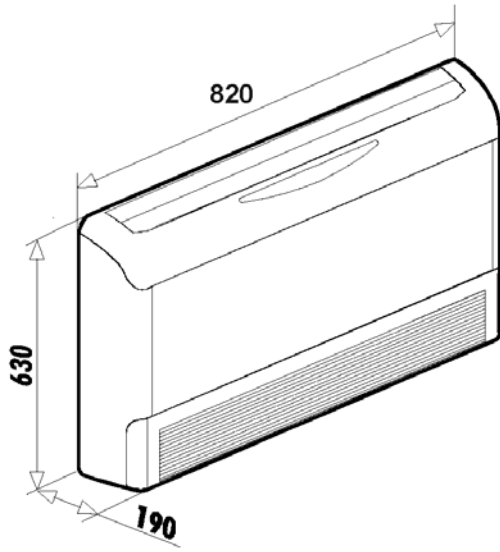

4.4 Indoor Unit: XLF09/12 DCI / AWSI-XLD009/012-N11

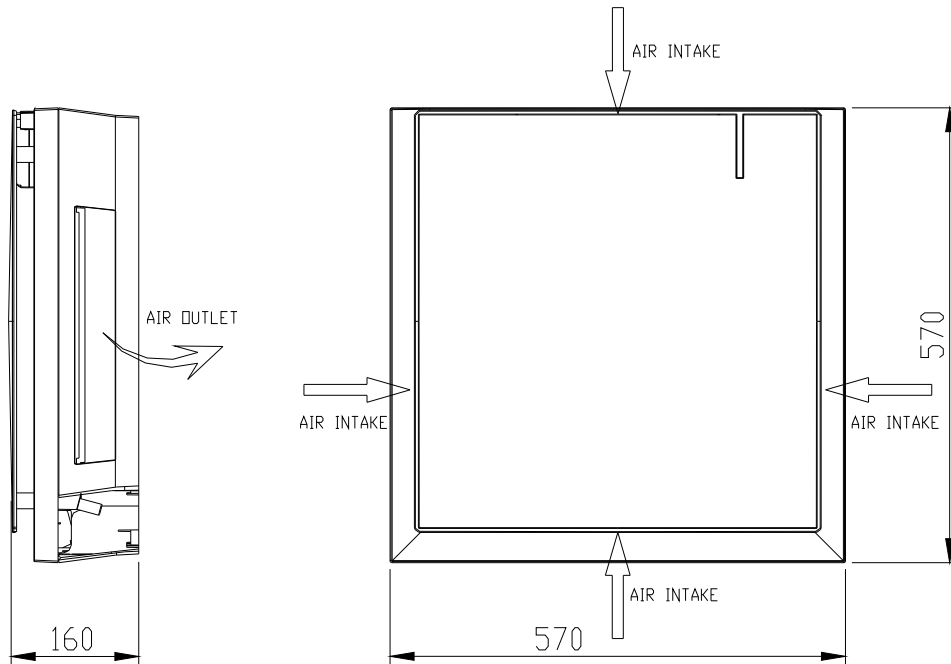
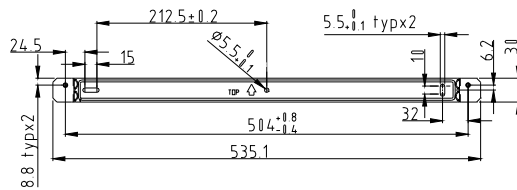

4.5 Indoor Unit: DLF09/12 DCI

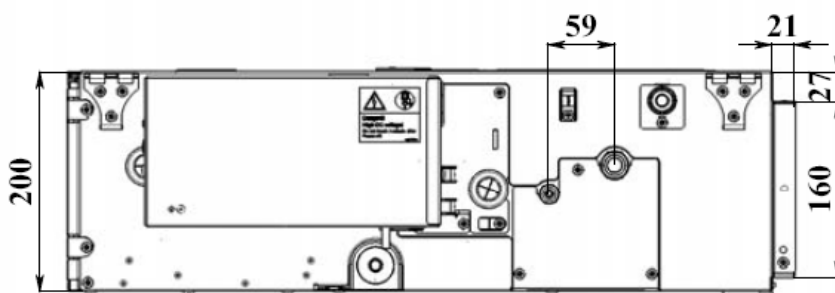
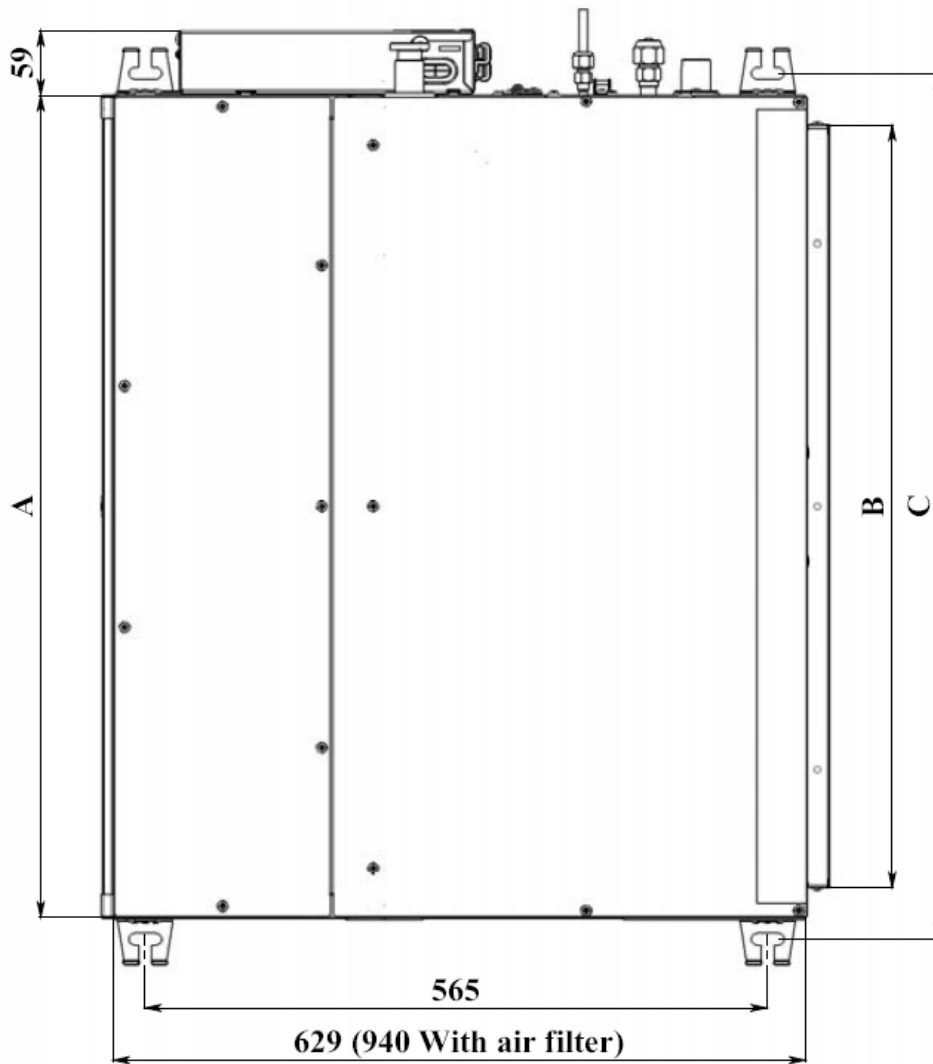

Nominal Capacity	A	B	C
2.5 -5.0 kW	750	696	790
6.0-7.2 kW	1050	996	1090

4.6 Indoor Unit: AWSI-HAD007/009-N11

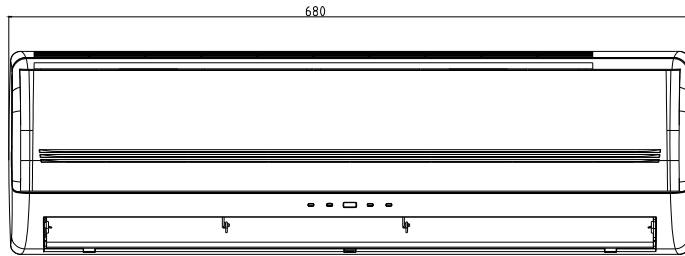
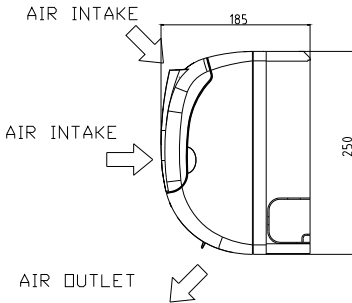
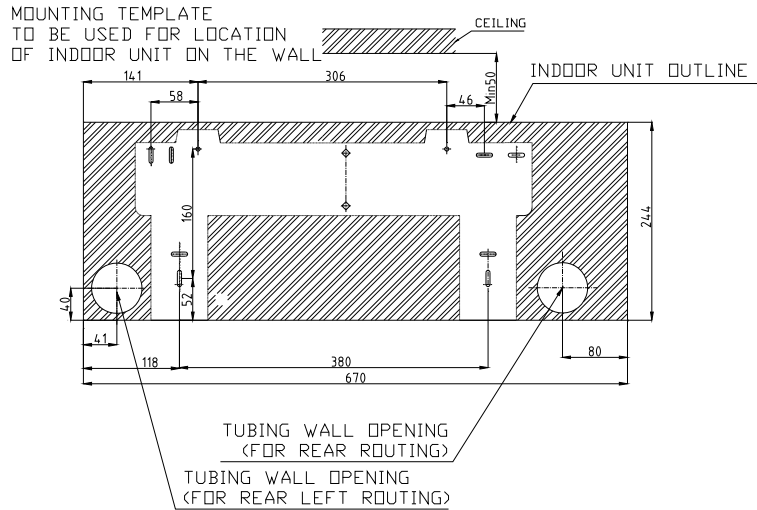

4.7 Indoor Unit: AWSI-HAD012-N11

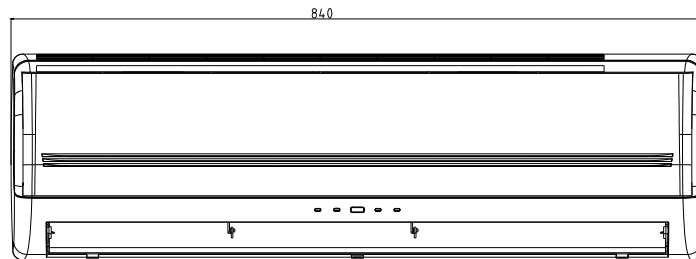
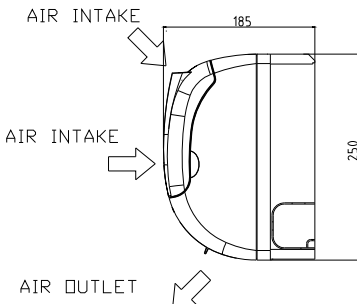
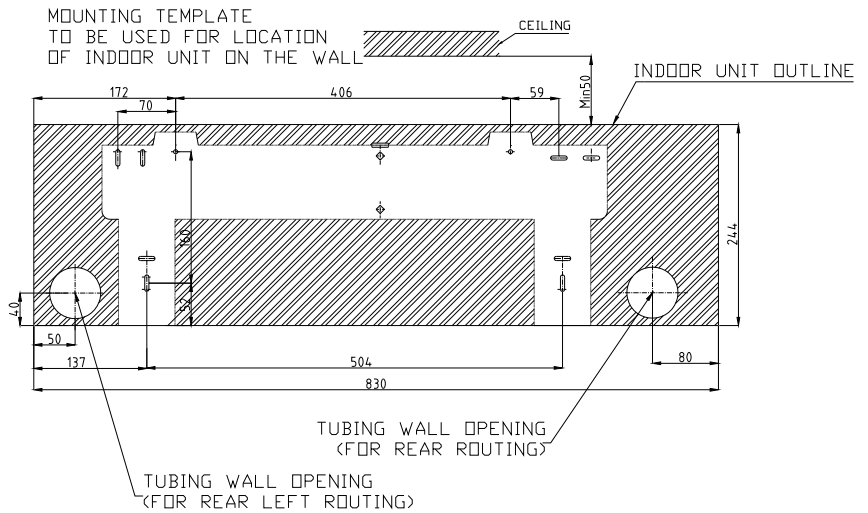

4.8 Indoor Unit: AWSI-HFD007/009-N11

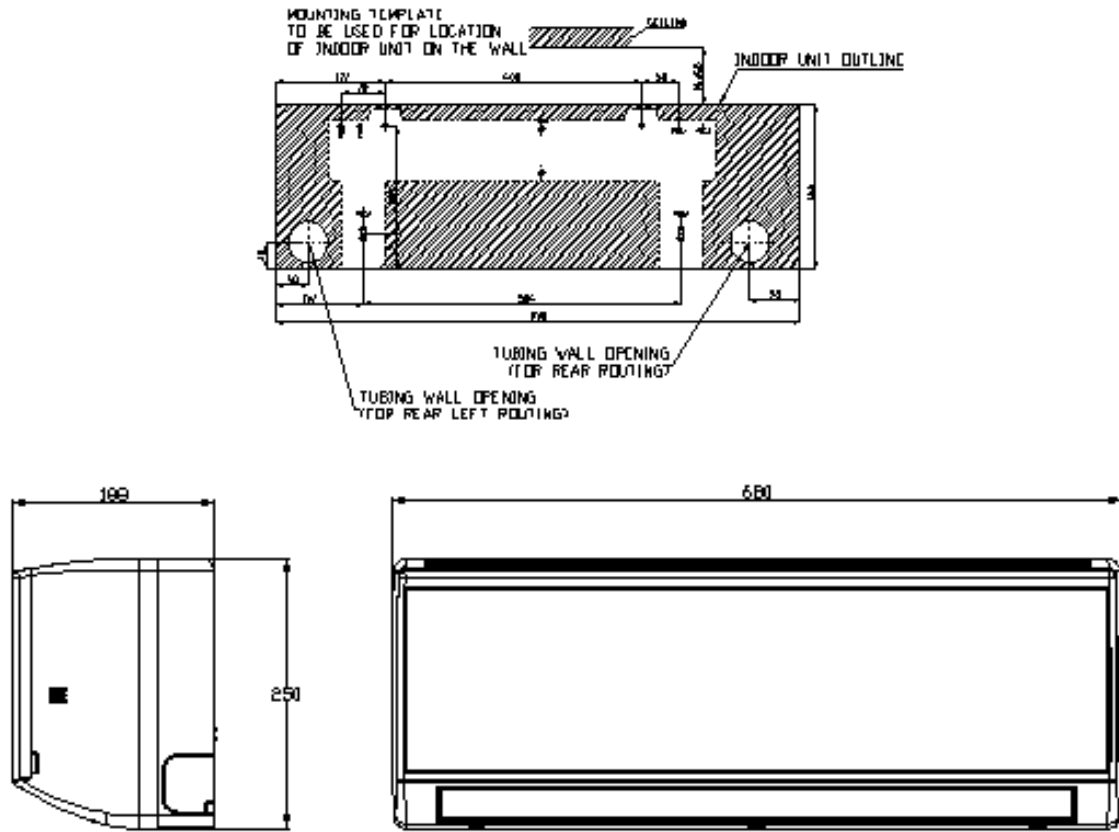

4.9 Indoor Unit: AWSI-HFD012-N11

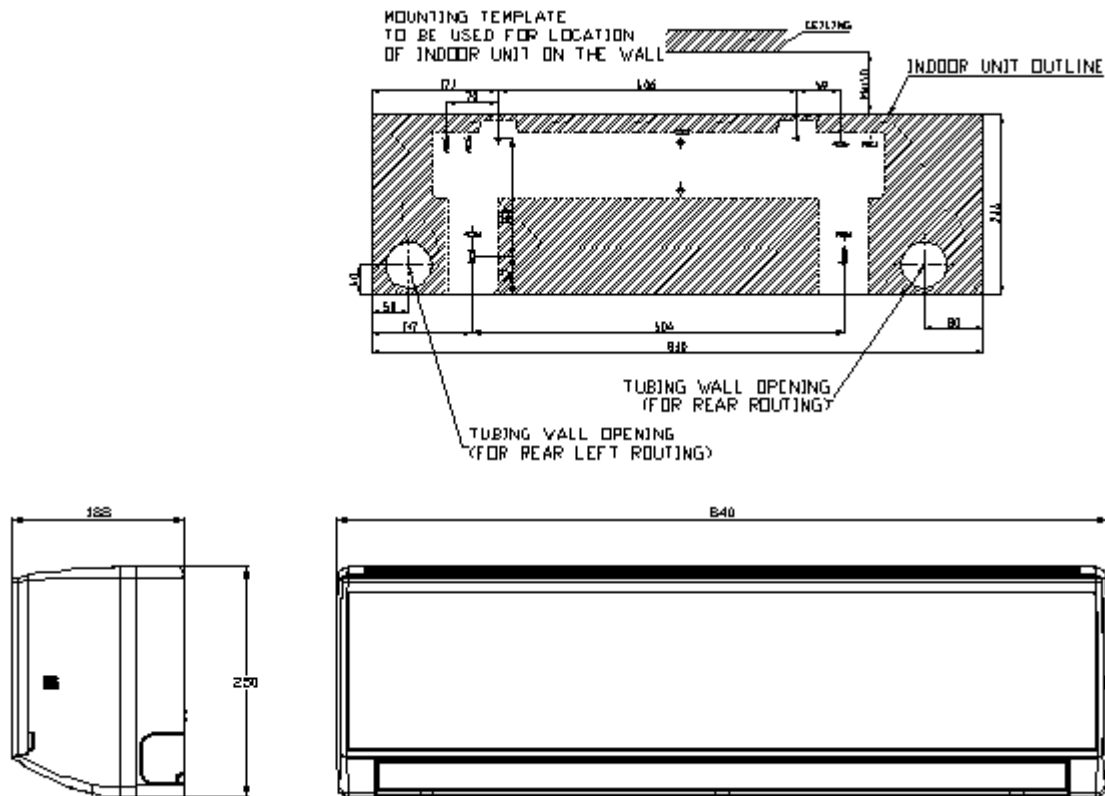

4.10 OUTDOOR UNIT: YAZ318

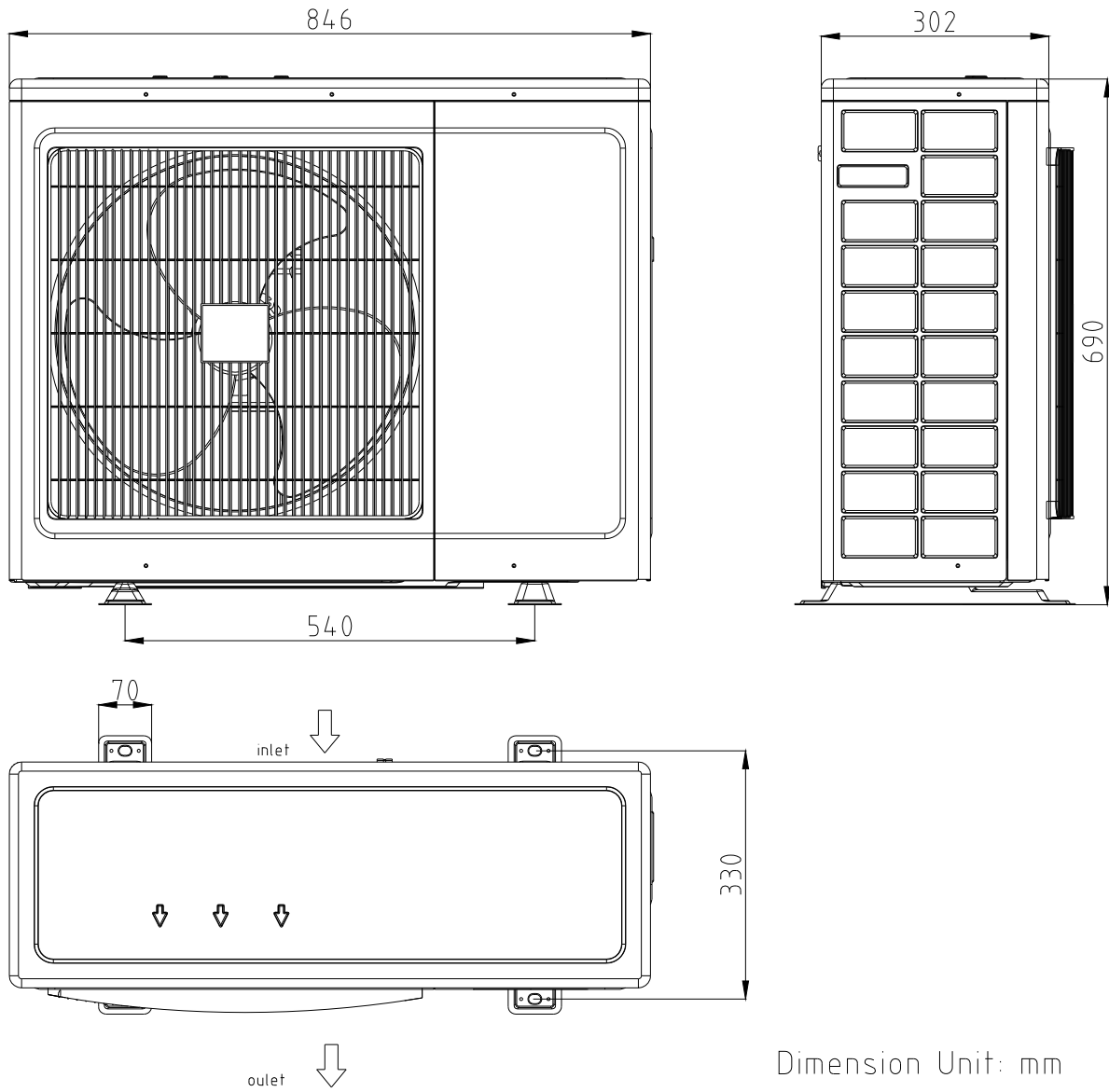

Dimension Unit: mm

5. PERFORMANCE DATA

5.1 Outdoor Unit YAZ318 DCI Combinations

5.1.1 Cooling

operating Indoor model	Capacity						Power Consumption [W]			COP Nominal	Energy Efficiency Class
	A	B	C	Nominal	Min.	Max.	Nominal	Min.	Max.		
7	2200			2200	1000	2600	645	450	750	3.41	A
9	2500			2500	1100	3500	740	510	1040	3.38	A
12	3500			3500	1200	4200	1020	510	1250	3.43	A
7+7	2200	2200		4400	1400	5200	1170	520	1500	3.76	A
7+9	2060	2640		4700	1450	6100	1220	530	1530	3.85	A
7+12	1920	3280		5200	1720	6200	1460	610	1910	3.56	A
9+9	2500	2500		5000	1710	6200	1400	610	1910	3.57	A
9+12	2230	2970		5200	1710	6280	1460	600	1930	3.56	A
12+12	2600	2600		5200	1800	6400	1460	635	2100	3.56	A
7+7+7	1730	1730	1730	5200	1860	6400	1460	635	2100	3.56	A
7+7+9	1580	1580	2030	5200	1870	6400	1460	635	2100	3.56	A
7+7+12	1400	1400	2400	5200	1870	6450	1460	635	2100	3.56	A
7+9+9	1460	1870	1870	5200	1870	6450	1460	635	2100	3.56	A
7+9+12	1300	1670	2230	5200	1880	6450	1460	640	2100	3.56	A
9+9+9	1730	1730	1730	5200	1860	6450	1460	640	2100	3.56	A
9+9+12	1560	1560	2080	5200	1880	6500	1460	640	2150	3.56	A

Nominal Indoor Units Combination

5.1.2 Heating

Operating indoor model	Capacity						Power Consumption [W]			COP Nominal	Energy Efficiency Class
	A	B	C	Nominal	Min.	Max.	Nominal	Min.	Max.		
7	2600			2600	1000	3000	710	450	800	3.66	A
9	3000			3000	1000	3500	800	450	920	3.75	A
12	4200			4200	1000	4500	1080	510	1160	3.89	A
7+7	2600	2600		5200	1600	6000	1400	460	1560	3.71	A
7+9	2450	3150		5600	1600	6500	1600	460	1750	3.50	A
7+12	2430	4170		6600	2000	7500	1710	510	1900	3.86	A
9+9	3000	3000		6000	1800	7000	1600	480	1750	3.75	A
9+12	2830	3770		6600	2000	7800	1710	510	1900	3.86	A
12+12	3300	3300		6600	2100	7800	1710	515	1900	3.86	A
7+7+7	2200	2200	2200	6600	2100	7800	1710	525	1900	3.86	A
7+7+9	2010	2010	2580	6600	2100	7800	1710	525	1900	3.86	A
7+7+12	1780	1780	3050	6600	2120	8000	1710	530	1900	3.86	A
7+9+9	1850	2380	2380	6600	2120	8000	1710	635	1900	3.86	A
7+9+12	1650	2120	2830	6600	2130	8000	1710	640	1900	3.86	A
9+9+9	2200	2200	2200	6600	2120	8000	1710	640	1900	3.86	A
9+9+12	1980	1980	2640	6600	2200	8150	1710	640	1900	3.86	A

Nominal Indoor Units Combination

5.2 PNXA009

5.2.1 Cooling Capacity Factors - Unit A,B
230[V] : Indoor Fan at High Speed.

OD COIL ENTERING AIR DB TEMPERATURE [°C]	DATA	ID COIL ENTERING AIR DB/WB TEMPERATURE [°C]				
		22/15	24/17	27/19	29/21	32/23
-10 - 20 (protection range)	TC	80 - 110 % of nominal				
	SC	80 - 105 % of nominal				
	PI	25 - 50 % of nominal				
25	TC	0.97	1.03	1.09	1.16	1.22
	SC	1.01	1.03	1.05	1.07	1.09
	PI	0.79	0.80	0.82	0.83	0.85
30	TC	0.92	0.98	1.05	1.11	1.17
	SC	0.98	1.00	1.03	1.05	1.07
	PI	0.88	0.89	0.91	0.92	0.94
35	TC	0.87	0.94	1.00	1.06	1.13
	SC	0.96	0.98	1.00	1.02	1.04
	PI	0.97	0.99	1.00	1.02	1.03
40	TC	0.83	0.89	0.95	1.02	1.08
	SC	0.93	0.95	0.97	1.00	1.02
	PI	1.06	1.08	1.09	1.11	1.12
46	TC	0.77	0.83	0.90	0.96	1.02
	SC	0.90	0.92	0.94	0.96	0.99
	PI	1.17	1.19	1.20	1.22	1.23

LEGEND

- TC – Total Cooling Capacity
- SC – Sensible Capacity
- PI – Power Input
- WB – Wet Bulb Temperature (°C)
- DB – Dry Bulb Temperature (°C)
- ID – Indoor
- OD - Outdoor

5.2.2 Capacity Correction Factors

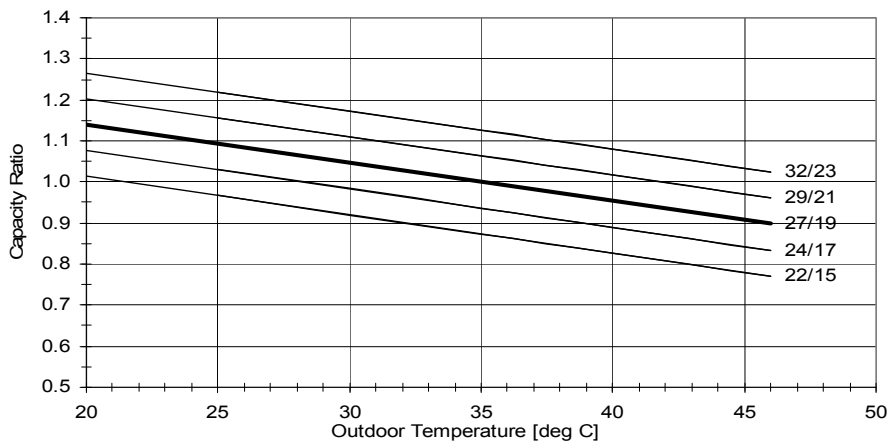

5.2.3 Heating Capacity Factors - Unit A,B

230[V] : Indoor Fan at High Speed.

OD COIL ENTERING AIR DB/WB TEMPERATURE [°C]	DATA	ID COIL ENTERING AIR DB TEMPERATURE [°C]		
		15	20	25
-15/-16	TC	0.64	0.59	0.55
	PI	0.60	0.66	0.72
-10/-12	TC	0.71	0.66	0.62
	PI	0.72	0.78	0.85
-7/-8	TC	0.76	0.72	0.67
	PI	0.82	0.88	0.94
-1/-2	TC	0.79	0.75	0.70
	PI	0.86	0.92	0.98
2/1	TC	0.81	0.76	0.72
	PI	0.89	0.95	1.01
7/6	TC	1.04	1.00	0.96
	PI	0.94	1.00	1.06
10/9	TC	1.10	1.06	1.01
	PI	1.00	1.06	1.12
15/12	TC	1.16	1.12	1.07
	PI	1.05	1.11	1.17
15-24 (Protection Range)	TC	85 - 105 % of nominal		
	PI	80 - 120 % of nominal		

LEGEND

- TC – Total Cooling Capacity
- SC – Sensible Capacity
- PI – Power Input
- WB – Wet Bulb Temperature (°C)
- DB – Dry Bulb Temperature (°C)
- ID – Indoor
- OD - Outdoor

5.2.4 Capacity Correction Factors

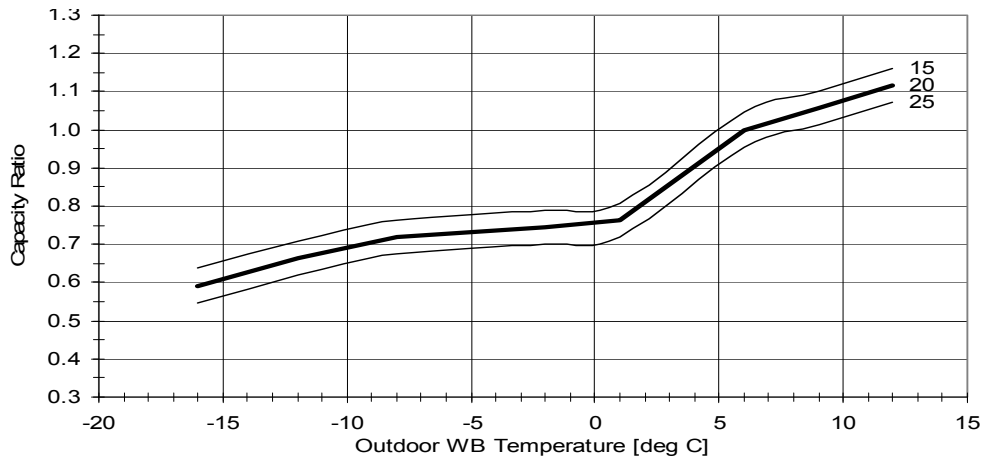

5.3 PNXA012

5.3.1 Cooling Capacity Factors - Unit A,B
230[V] : Indoor Fan at High Speed.

		ID COIL ENTERING AIR DB/WB TEMPERATURE [°C]				
OD COIL ENTERING AIR DB TEMPERATURE [°C]	DATA	22/15	24/17	27/19	29/21	32/23
-10 - 20 (protection range)	TC	80 - 110 % of nominal				
	SC	80 - 105 % of nominal				
	PI	25 - 50 % of nominal				
25	TC	0.97	1.03	1.09	1.16	1.22
	SC	1.01	1.03	1.05	1.07	1.09
	PI	0.79	0.80	0.82	0.83	0.85
30	TC	0.92	0.98	1.05	1.11	1.17
	SC	0.98	1.00	1.03	1.05	1.07
	PI	0.88	0.89	0.91	0.92	0.94
35	TC	0.87	0.94	1.00	1.06	1.13
	SC	0.96	0.98	1.00	1.02	1.04
	PI	0.97	0.99	1.00	1.02	1.03
40	TC	0.83	0.89	0.95	1.02	1.08
	SC	0.93	0.95	0.97	1.00	1.02
	PI	1.06	1.08	1.09	1.11	1.12
46	TC	0.77	0.83	0.90	0.96	1.02
	SC	0.90	0.92	0.94	0.96	0.99
	PI	1.17	1.19	1.20	1.22	1.23

LEGEND

- TC – Total Cooling Capacity
- SC – Sensible Capacity
- PI – Power Input
- WB – Wet Bulb Temperature (°C)
- DB – Dry Bulb Temperature (°C)
- ID – Indoor
- OD - Outdoor

5.3.2 Capacity Correction Factors

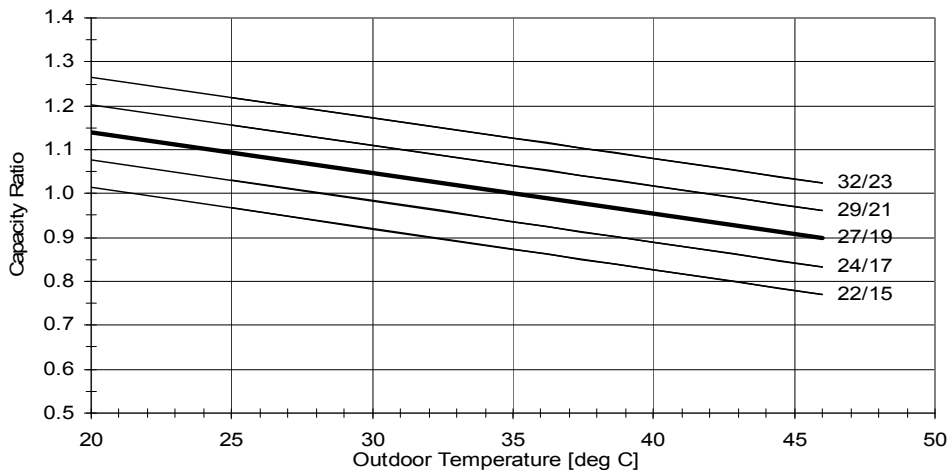

5.3.3 Heating Capacity Factors - Unit A,B

230[V] : Indoor Fan at High Speed.

OD COIL ENTERING AIR DB/WB TEMPERATURE [°C]	DATA	ID COIL ENTERING AIR DB TEMPERATURE [°C]		
		15	20	25
-15/-16	TC	0.64	0.59	0.55
	PI	0.60	0.66	0.72
-10/-12	TC	0.71	0.66	0.62
	PI	0.72	0.78	0.85
-7/-8	TC	0.76	0.72	0.67
	PI	0.82	0.88	0.94
-1/-2	TC	0.79	0.75	0.70
	PI	0.86	0.92	0.98
2/1	TC	0.81	0.76	0.72
	PI	0.89	0.95	1.01
7/6	TC	1.04	1.00	0.96
	PI	0.94	1.00	1.06
10/9	TC	1.10	1.06	1.01
	PI	1.00	1.06	1.12
15/12	TC	1.16	1.12	1.07
	PI	1.05	1.11	1.17
15-24 (Protection Range)	TC	85 - 105 % of nominal		
	PI	80 - 120 % of nominal		

LEGEND

- TC – Total Cooling Capacity
- SC – Sensible Capacity
- PI – Power Input
- WB – Wet Bulb Temperature (°C)
- DB – Dry Bulb Temperature (°C)
- ID – Indoor
- OD - Outdoor

5.3.4 Capacity Correction Factors

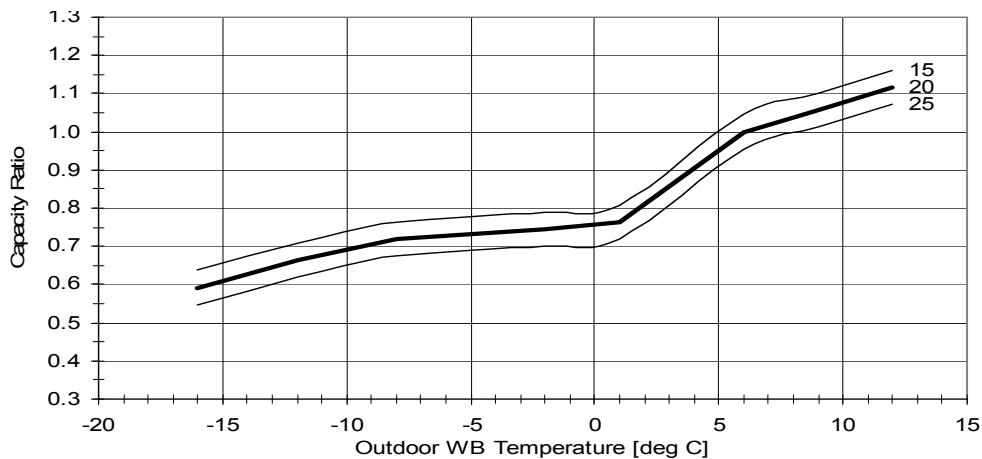

5.4 CK09 DCI

5.4.1 Cooling Capacity Factors - Unit A,B

230[V] : Indoor Fan at High Speed.

OD COIL ENTERING AIR DB TEMPERATURE [°C]	DATA	ID COIL ENTERING AIR DB/WB TEMPERATURE [°C]				
		22/15	24/17	27/19	29/21	32/23
-10 - 20 (protection range)	TC	80 - 110 % of nominal				
	SC	80 - 105 % of nominal				
	PI	25 - 50 % of nominal				
25	TC	0.97	1.03	1.09	1.16	1.22
	SC	1.01	1.03	1.05	1.07	1.09
	PI	0.79	0.80	0.82	0.83	0.85
30	TC	0.92	0.98	1.05	1.11	1.17
	SC	0.98	1.00	1.03	1.05	1.07
	PI	0.88	0.89	0.91	0.92	0.94
35	TC	0.87	0.94	1.00	1.06	1.13
	SC	0.96	0.98	1.00	1.02	1.04
	PI	0.97	0.99	1.00	1.02	1.03
40	TC	0.83	0.89	0.95	1.02	1.08
	SC	0.93	0.95	0.97	1.00	1.02
	PI	1.06	1.08	1.09	1.11	1.12
46	TC	0.77	0.83	0.90	0.96	1.02
	SC	0.90	0.92	0.94	0.96	0.99
	PI	1.17	1.19	1.20	1.22	1.23

LEGEND

- TC – Total Cooling Capacity
- SC – Sensible Capacity
- PI – Power Input
- WB – Wet Bulb Temperature (°C)
- DB – Dry Bulb Temperature (°C)
- ID – Indoor
- OD - Outdoor

5.4.2 Capacity Correction Factors

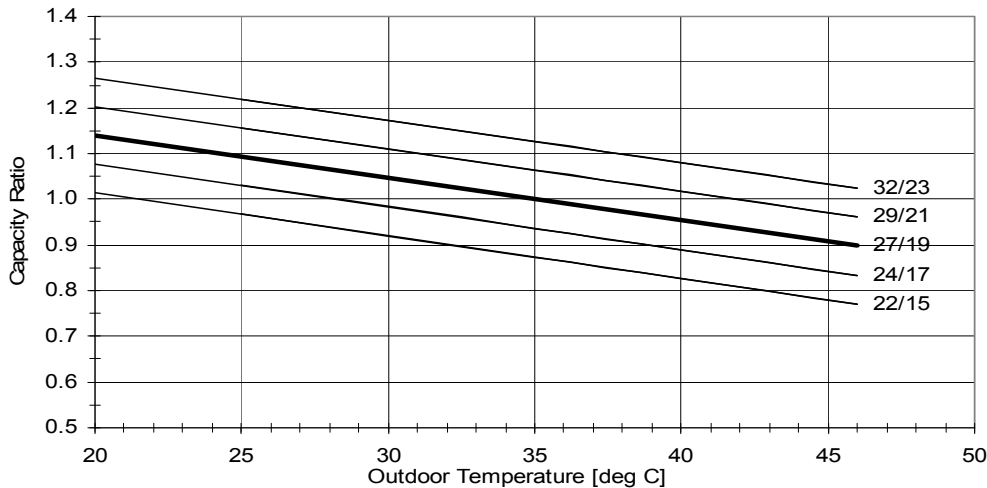

5.4.3 Heating Capacity Factors - Unit A,B

230[V] : Indoor Fan at High Speed.

OD COIL ENTERING AIR DB/WB TEMPERATURE [°C]	DATA	ID COIL ENTERING AIR DB TEMPERATURE [°C]		
		15	20	25
-15/-16	TC	0.64	0.59	0.55
	PI	0.60	0.66	0.72
-10/-12	TC	0.71	0.66	0.62
	PI	0.72	0.78	0.85
-7/-8	TC	0.76	0.72	0.67
	PI	0.82	0.88	0.94
-1/-2	TC	0.79	0.75	0.70
	PI	0.86	0.92	0.98
2/1	TC	0.81	0.76	0.72
	PI	0.89	0.95	1.01
7/6	TC	1.04	1.00	0.96
	PI	0.94	1.00	1.06
10/9	TC	1.10	1.06	1.01
	PI	1.00	1.06	1.12
15/12	TC	1.16	1.12	1.07
	PI	1.05	1.11	1.17
15-24 (Protection Range)	TC	85 - 105 % of nominal		
	PI	80 - 120 % of nominal		

LEGEND

- TC – Total Cooling Capacity
- SC – Sensible Capacity
- PI – Power Input
- WB – Wet Bulb Temperature (°C)
- DB – Dry Bulb Temperature (°C)
- ID – Indoor
- OD - Outdoor

5.4.4 Capacity Correction Factors

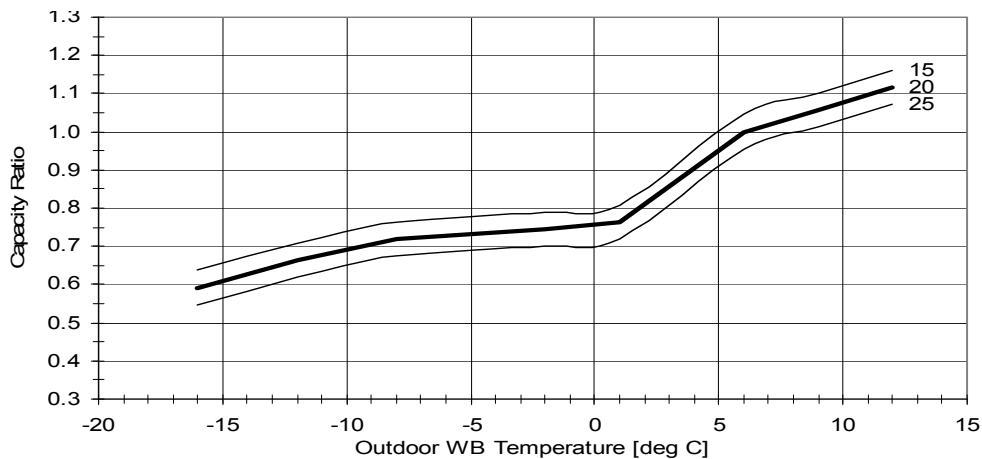

5.5 CK12 DCI

5.5.1 Cooling Capacity Factors - Unit A,B

230[V] : Indoor Fan at High Speed.

OD COIL ENTERING AIR DB TEMPERATURE [°C]	DATA	ID COIL ENTERING AIR DB/WB TEMPERATURE [°C]				
		22/15	24/17	27/19	29/21	32/23
-10 - 20 (protection range)	TC	80 - 110 % of nominal				
	SC	80 - 105 % of nominal				
	PI	25 - 50 % of nominal				
25	TC	0.97	1.03	1.09	1.16	1.22
	SC	1.01	1.03	1.05	1.07	1.09
	PI	0.79	0.80	0.82	0.83	0.85
30	TC	0.92	0.98	1.05	1.11	1.17
	SC	0.98	1.00	1.03	1.05	1.07
	PI	0.88	0.89	0.91	0.92	0.94
35	TC	0.87	0.94	1.00	1.06	1.13
	SC	0.96	0.98	1.00	1.02	1.04
	PI	0.97	0.99	1.00	1.02	1.03
40	TC	0.83	0.89	0.95	1.02	1.08
	SC	0.93	0.95	0.97	1.00	1.02
	PI	1.06	1.08	1.09	1.11	1.12
46	TC	0.77	0.83	0.90	0.96	1.02
	SC	0.90	0.92	0.94	0.96	0.99
	PI	1.17	1.19	1.20	1.22	1.23

LEGEND

- TC – Total Cooling Capacity
- SC – Sensible Capacity
- PI – Power Input
- WB – Wet Bulb Temperature (°C)
- DB – Dry Bulb Temperature (°C)
- ID – Indoor
- OD - Outdoor

5.5.2 Capacity Correction Factors

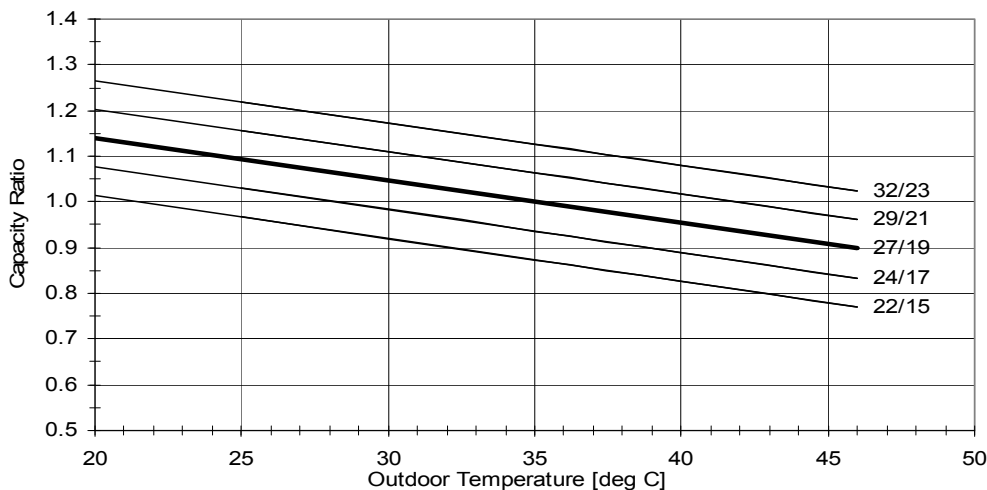

5.5.3 Heating Capacity Factors - Unit A,B

230[V] : Indoor Fan at High Speed.

OD COIL ENTERING AIR DB/WB TEMPERATURE [°C]	DATA	ID COIL ENTERING AIR DB TEMPERATURE [°C]		
		15	20	25
-15/-16	TC	0.64	0.59	0.55
	PI	0.60	0.66	0.72
-10/-12	TC	0.71	0.66	0.62
	PI	0.72	0.78	0.85
-7/-8	TC	0.76	0.72	0.67
	PI	0.82	0.88	0.94
-1/-2	TC	0.79	0.75	0.70
	PI	0.86	0.92	0.98
2/1	TC	0.81	0.76	0.72
	PI	0.89	0.95	1.01
7/6	TC	1.04	1.00	0.96
	PI	0.94	1.00	1.06
10/9	TC	1.10	1.06	1.01
	PI	1.00	1.06	1.12
15/12	TC	1.16	1.12	1.07
	PI	1.05	1.11	1.17
15-24 (Protection Range)	TC	85 - 105 % of nominal		
	PI	80 - 120 % of nominal		

LEGEND

- TC – Total Cooling Capacity
- SC – Sensible Capacity
- PI – Power Input
- WB – Wet Bulb Temperature (°C)
- DB – Dry Bulb Temperature (°C)
- ID – Indoor
- OD - Outdoor

5.5.4 Capacity Correction Factors

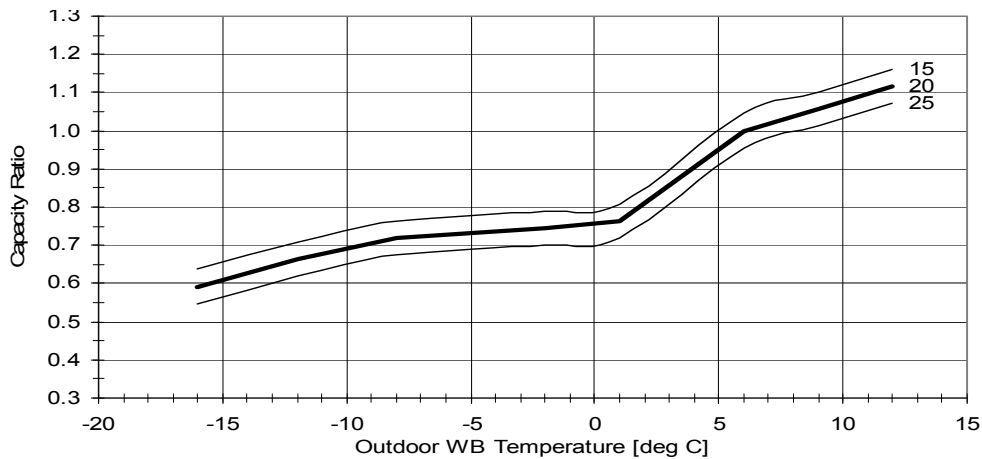

5.6 Tubing Length Capacity Correction Factor

5.6.1 Cooling

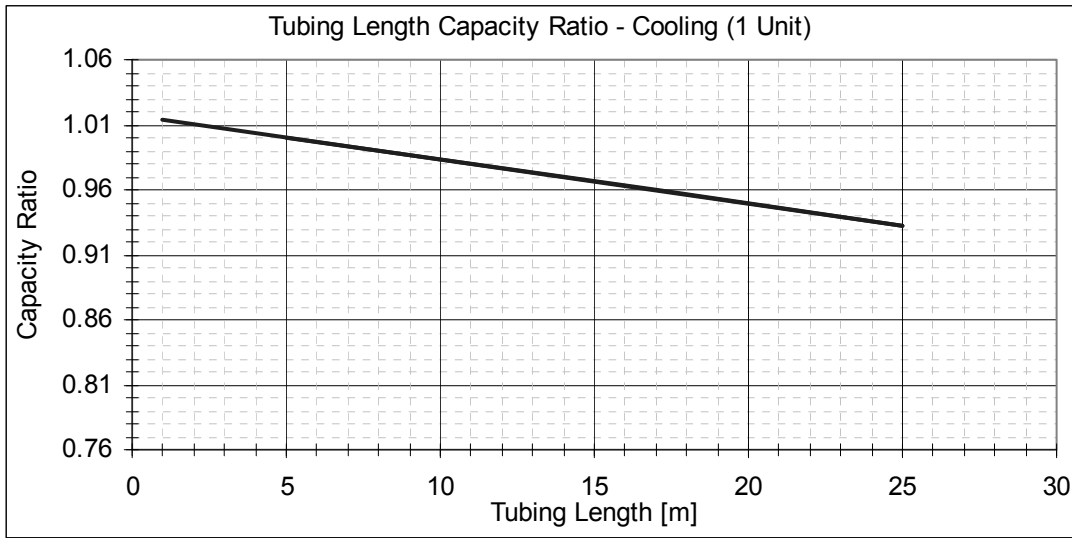

5.6.2 Heating

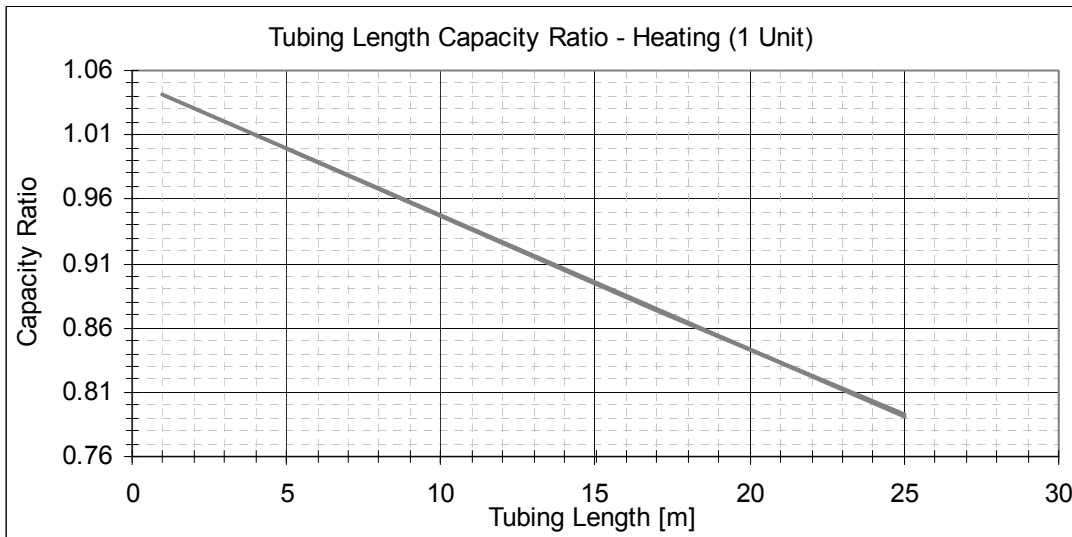

6. OPERATING CURVES

6.1 Model: YAZ3 018 DCI

6.1.1 Cooling – Technician Mode

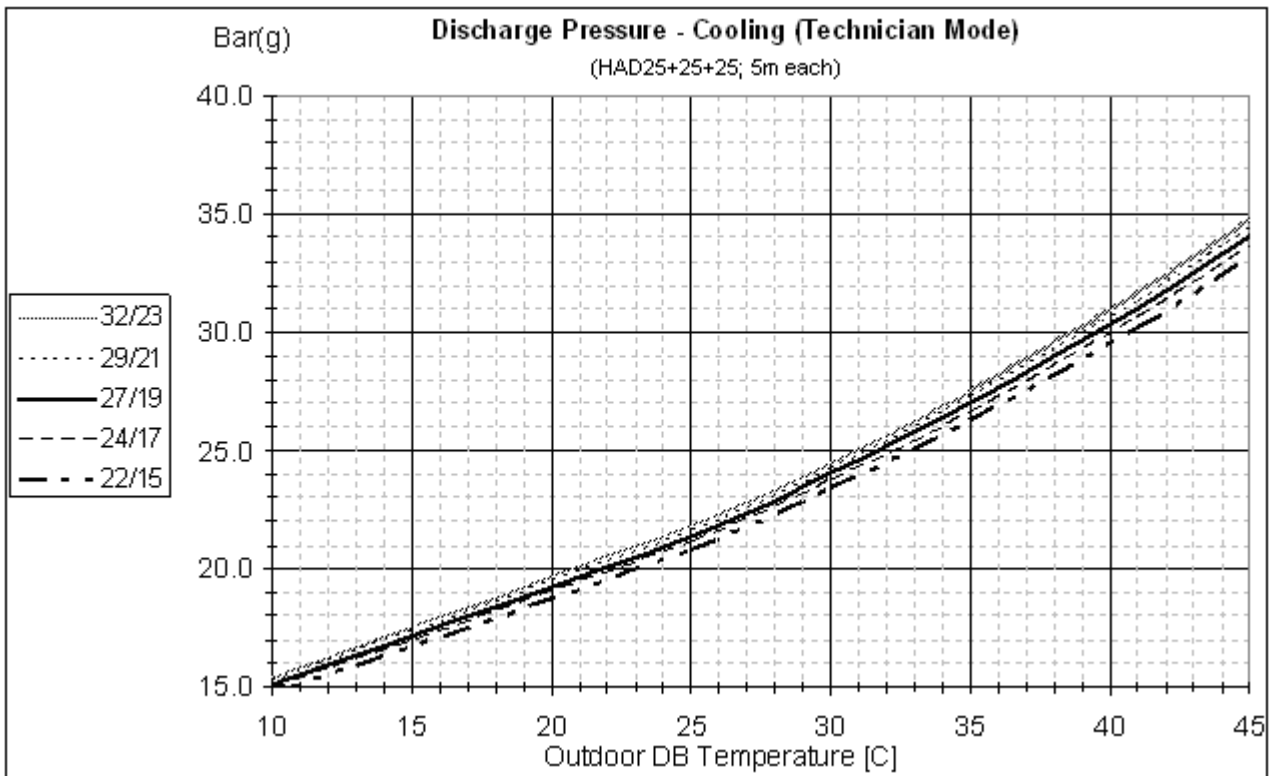
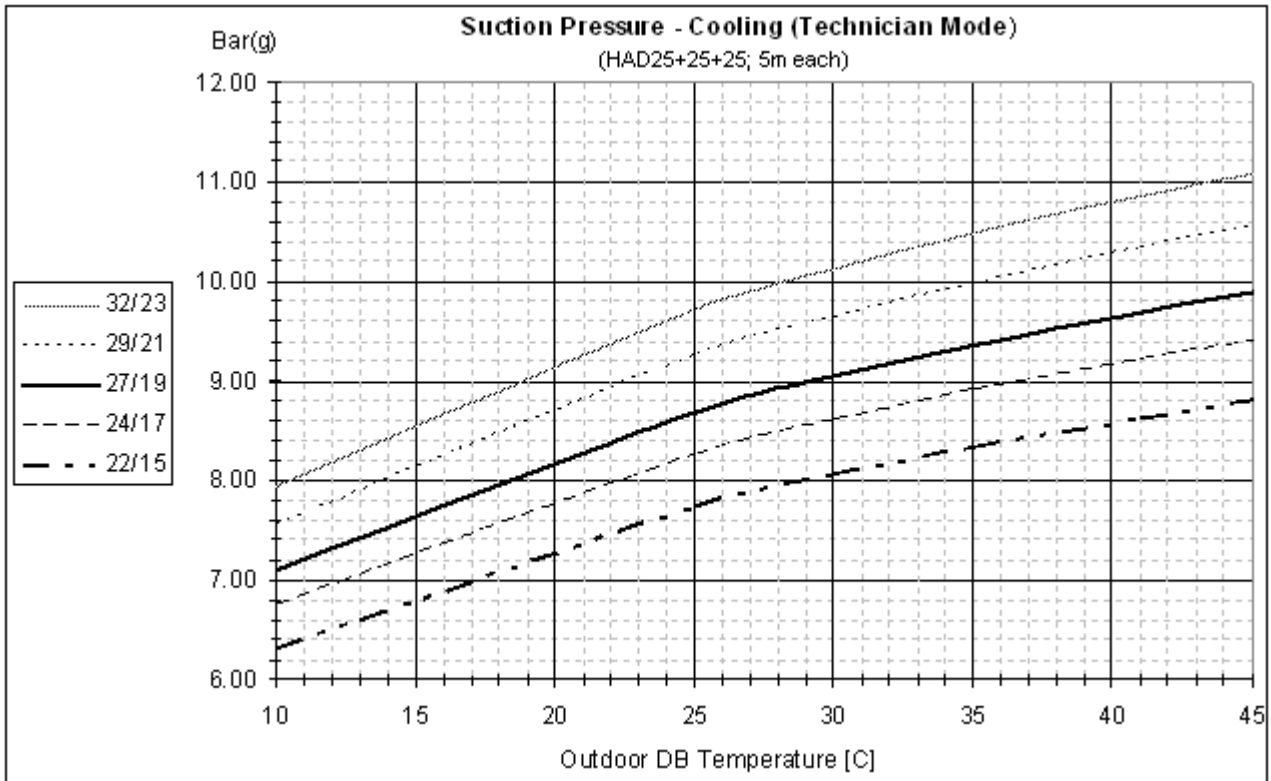

6.1.2 Heating – Technician Mode

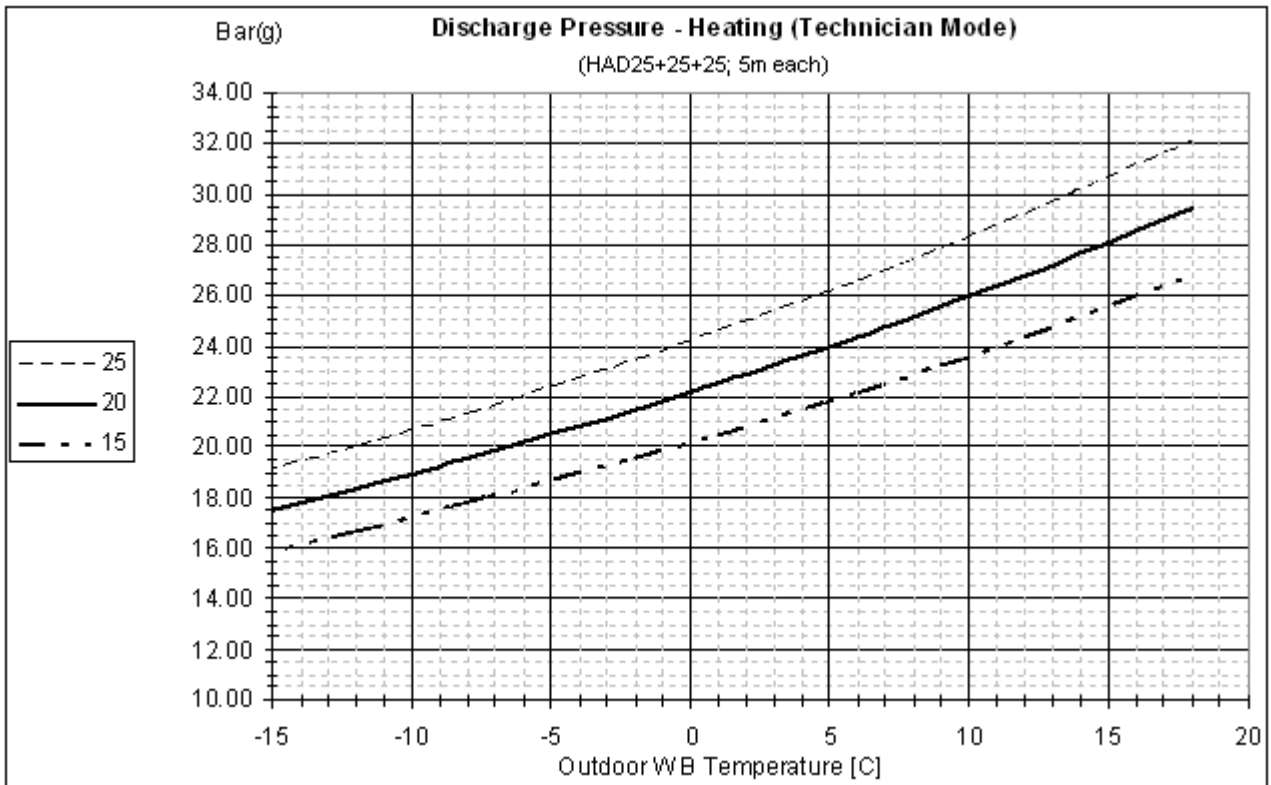
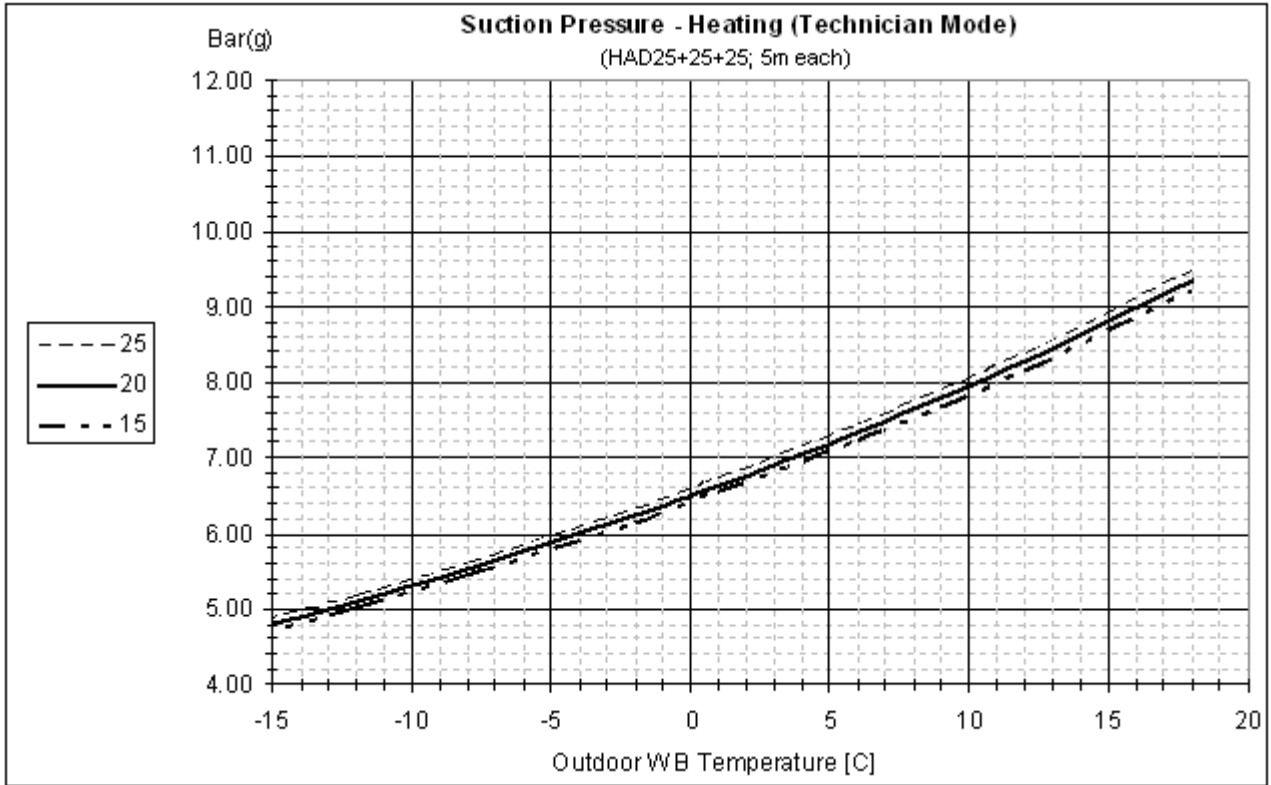

6.1.3 Tubing Length correction Factor

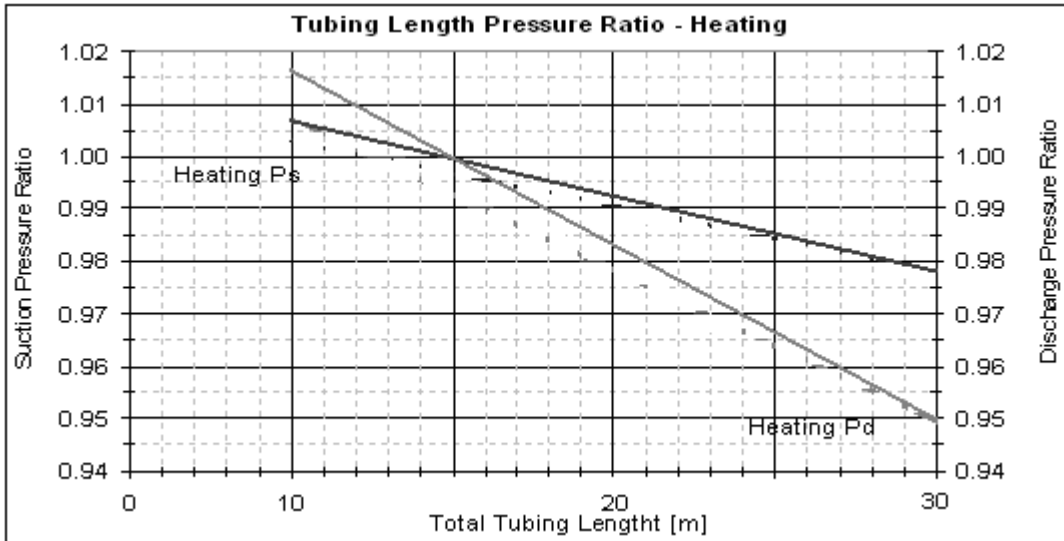
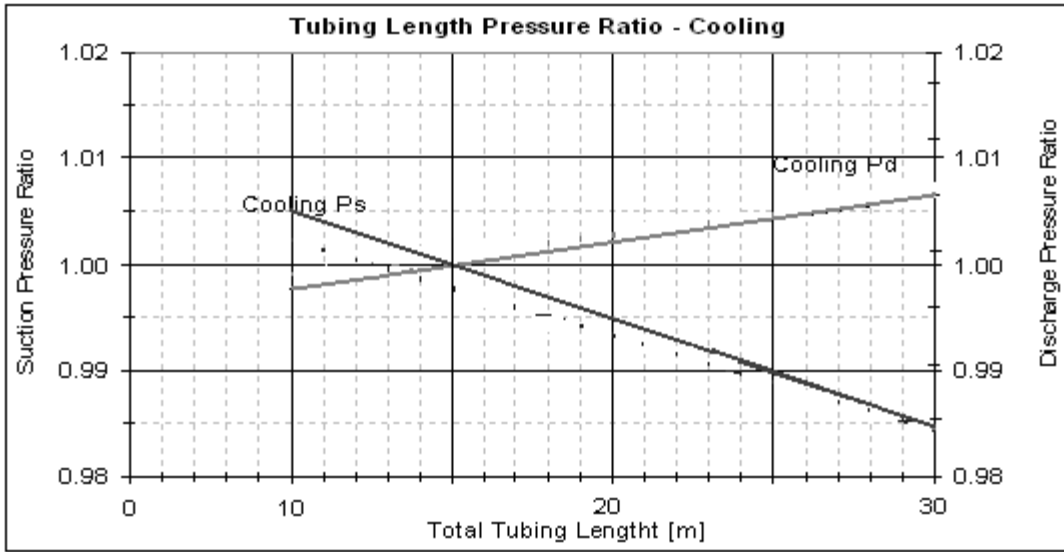

7. ELECTRICAL DATA

Power Supply	1 PH, 220-240 VAC, 50Hz
Connected to	Outdoor
Maximum Current	13.7 A
Inrush Current	35 A
Starting Current	10A
Circuit breaker	20A
Power supply wiring no. x cross section	3 X 2.0 mm ²
Interconnecting cable no. x cross section	4 X 1.5 mm ² (For each IDU)

Note:

- Inrush current is the current when power is up. (charging the DC capacitors at outdoor unit controller).
- Starting current is the current when starting the compressor

NOTE

Power wiring cord should comply with local laws and electrical regulations requirements.

8. WIRING DIAGRAM

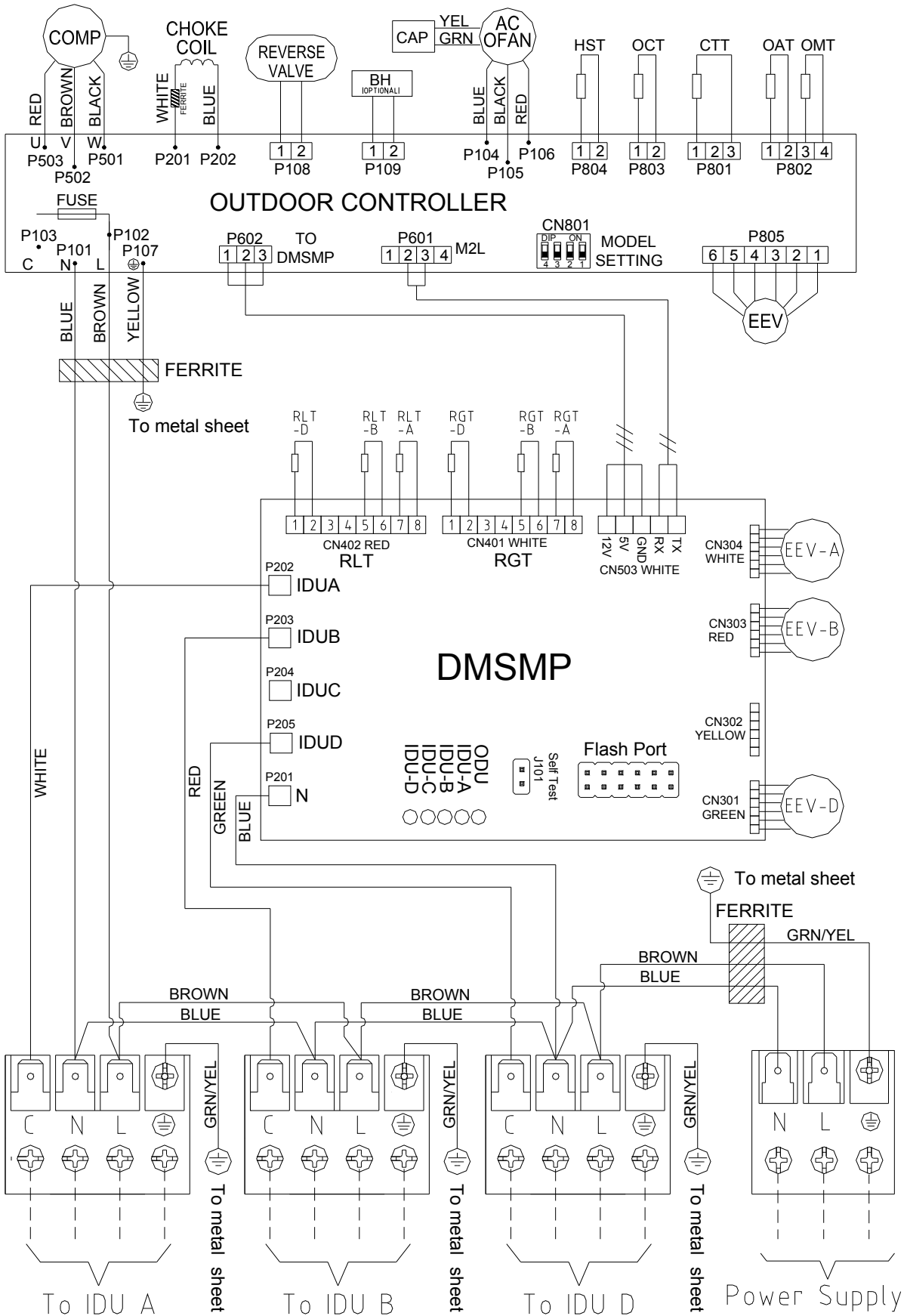

9. REFRIGERATION DIAGRAM

9.1 YAZ318 Cooling Mode

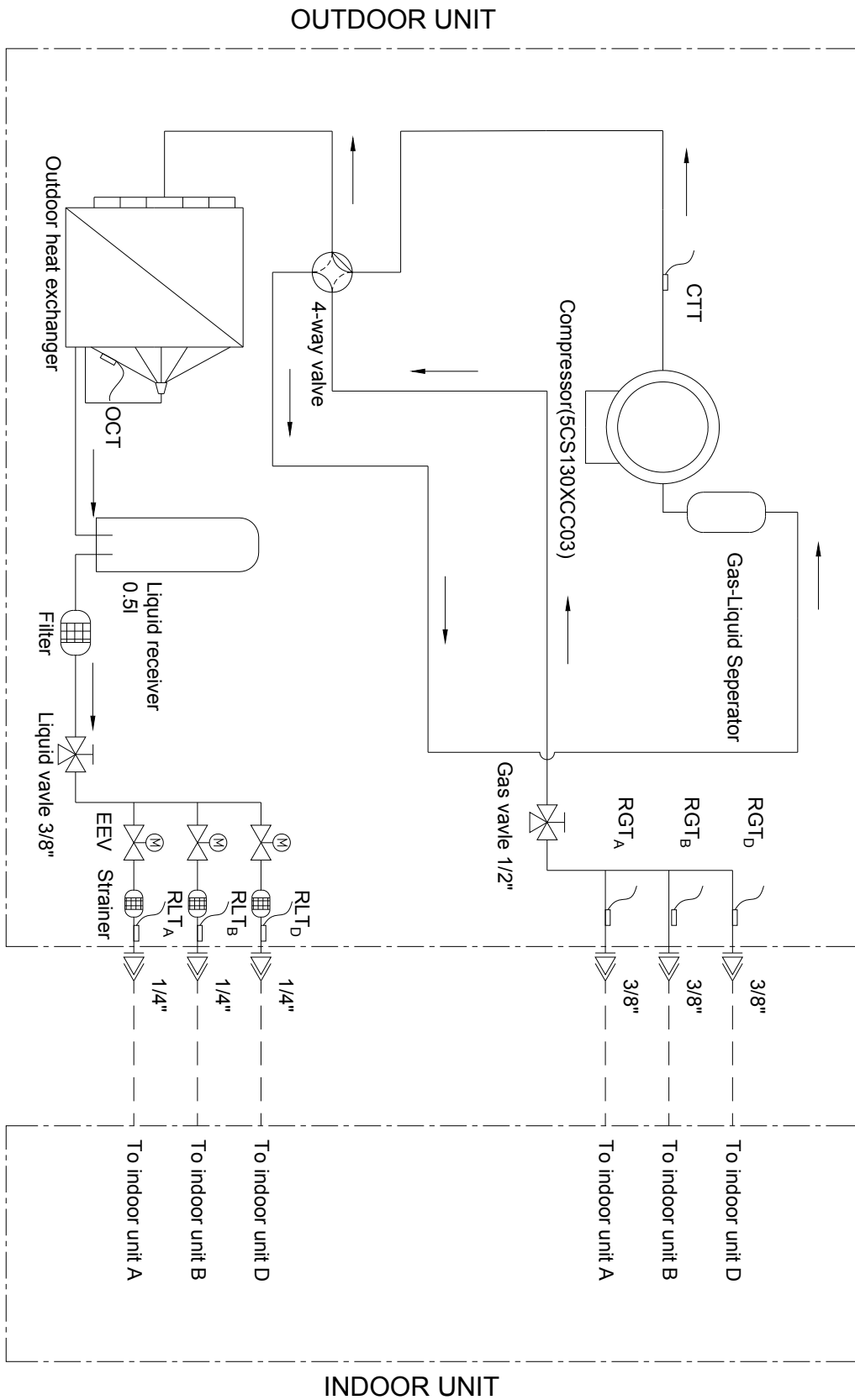

9.2 YAZ318 Heating Mode

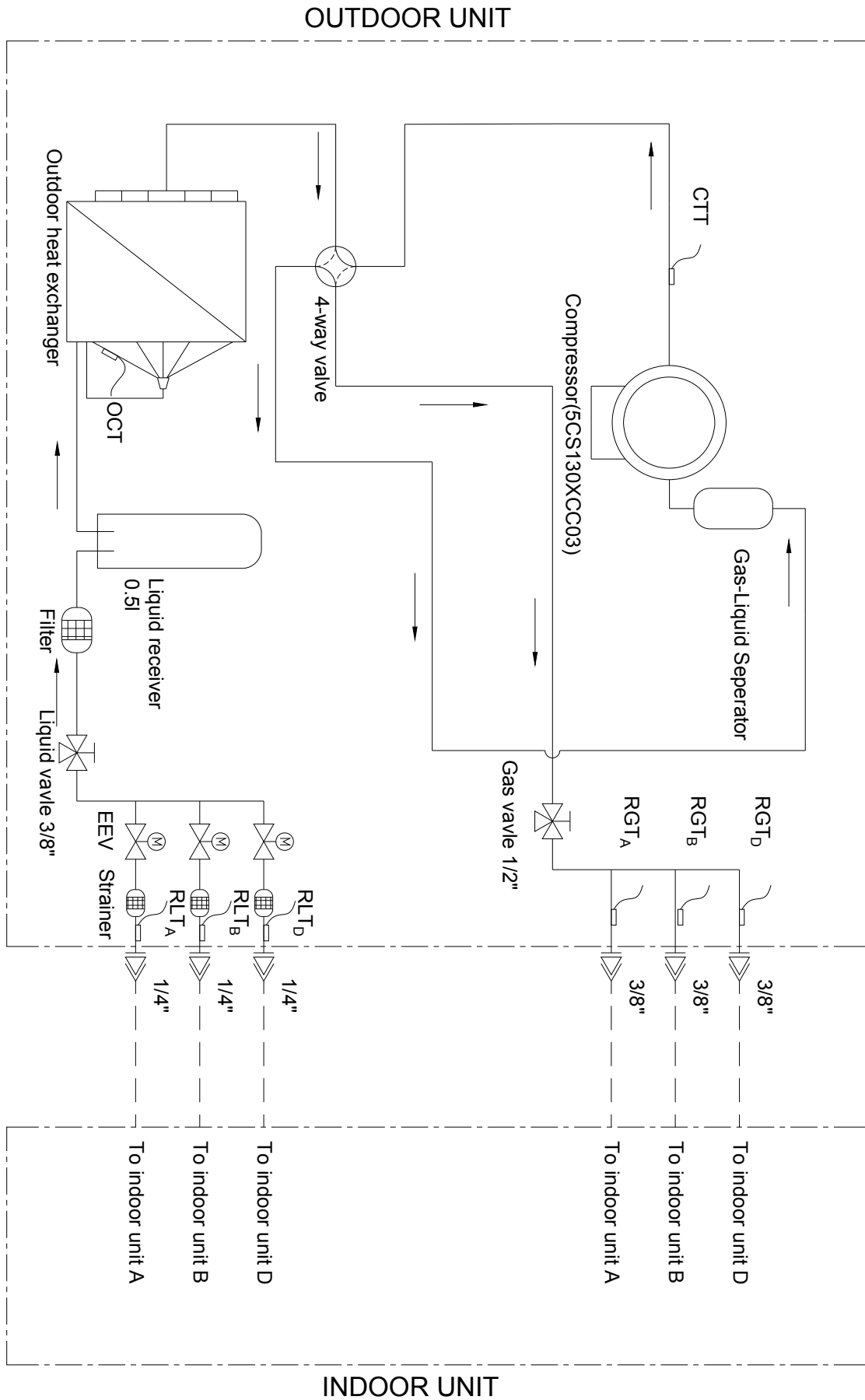

10. TUBING CONNECTIONS

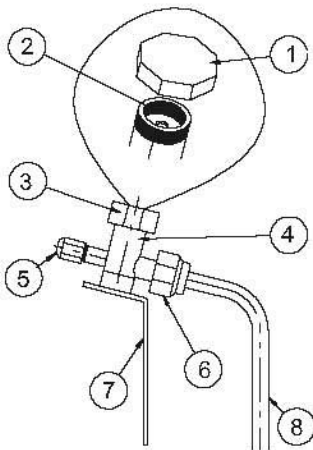
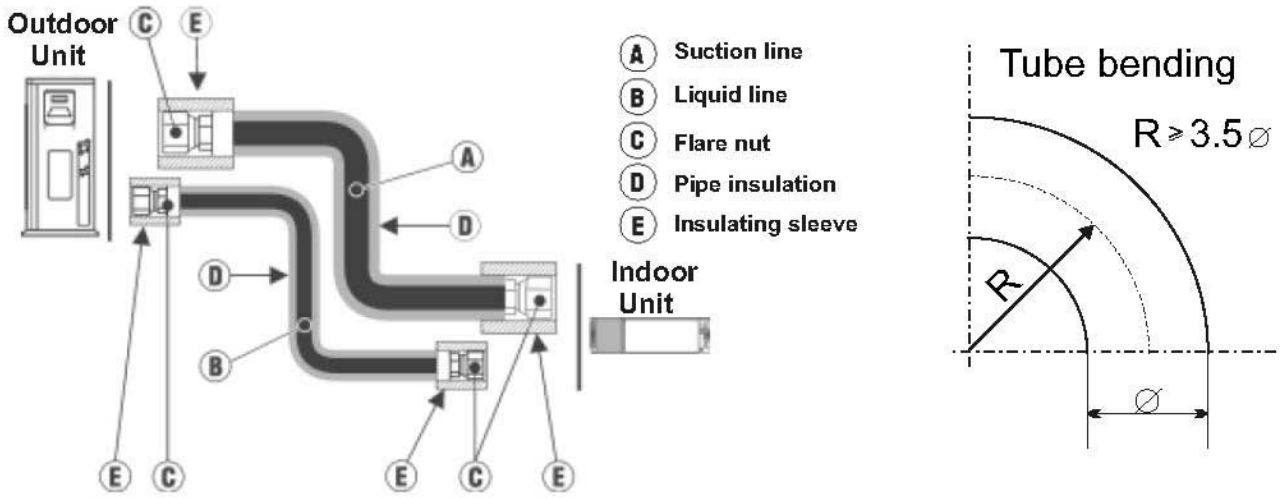

Tube (Inch)	1/4"	3/8"	1/2"	5/8"	3/4"
TORQUE(N.m.)					
FLARE NUTS	11-13	40-45	60-65	70-75	80-85
VALVE CAP	13-20	13-20	18-25	18-25	40-50
SERVICE PORT CAP	11-13	11-13	11-13	11-13	11-13

Tightening Torque Values

1. Valve Protection Cap-end
2. Use Allen Wrench to open/close the Refrigerant Valve
3. Valve Protection Cap
4. Refrigerant Valve
5. Service Port Cap
6. Flare Nut
7. Unit Back Side
8. Copper Tube

When the outdoor unit is installed above the indoor unit an oil trap is required every 5m along the suction line at the lowest point of the riser. In case the indoor unit is installed above the outdoor no trap is required.

11. CONTROL SYSTEM

11.1 Abbreviations

Abbreviation	Definition
A/C	Air Condition
BMS	Building Management System
PWR	System Power
CTT	Compressor Top Temperature sensor
DCI	DC Inverter
EEV	Electronic Expansion Valve
HE	Heating Element
HMI	Human Machine Interface
HST	Heat Sink Temperature sensor
Hz	Hertz (1/sec) – electrical frequency
ICT	Indoor Coil Temperature (RT2) sensor
IDU	Indoor Unit
MCU	Micro Controller Unit
OAT	Outdoor Air Temperature sensor
OCT	ODU Coil Temperature sensor
OMT	Outdoor middle coil temperature
ODU	Outdoor Unit
OFAN	Outdoor Fan
PFC	Power Factor Corrector
RAC	Residential A/C
RC	Reverse Cycle (Heat Pump)
RGT	Return Gas Temperature sensor
RLT	Return Liquid Temperature sensor
RPS	Rounds per second (mechanical speed)
RV	Reverse Valve
SB,STBY	Stand By
S/W	Software
TBD	To Be Defined
TMR	Timer

11.2 Product Overview

11.2.1 Compressor

DC brush less and sensor less motor inverter driven compressor.

11.2.2 Outdoor Fan

AC motor.

11.2.3 RV

Reverse Valve set the direction of refrigerant flow in the system, thus setting the operation mode for cooling or heating.

When the solenoid is powered, system will work in heat mode.

11.2.4 EEV's

Expansion valve operated by step motor which controls the size of the orifice.

11.2.5 HMI

Three "7-Segments"

11.2.6 Temperature Sensors

CTT – Compressor Top Temperature

OAT – Outdoor Air Temperature

OMT– Outdoor middle coil temperature

OCT – Outdoor Coil (heat exchanger) Temperature

HST – Heat Sink Temperature

RGT1..4 – Indoor Unit 1..4 Returned Gas Temperatures

RLT 1..4 – Indoor Unit 1..4 Returned Liquid Temperatures

11.2.7 Base Heater

Heating element designed to melt any ice that is accumulated on the outdoor unit base during low heating operation.

11.3 General Operating Rules

11.3.1 Initialization

Initialization process is the first operation done each time power is up.

The targets of the initialization are:

- Addressing of IDU's
- Identification of connected IDU's
- IDU Matching Check
- EEV's homing (reset position)
- Restoring Parameters from EEPROM/Jumpers/Dipswitches

11.3.1.1 IDU's Initialization

11.3.1.1.1 Capacity Codes Setting

The capacity groups of the IDU's are translated into capacity codes according to the following table:

Capacity group	Capacity Code
0 (2.0 - 2.9kw)	1.2
1 (3.0 - 3.9kw)	1.5
2 (4.0 - 4.9kw)	1.7
3 (5.0 to 6.0)	2
4 (6.1kw and above)	3

11.3.1.1.2 Indoor Total Capacity Test

This test is performed only for Multi split units.
 The test comes to check the total IDU capacity code to match the outdoor unit capacity.
 The capacity groups of the IDU's are translated into capacity codes according to the following table:

Capacity group	Capacity Code
0	1
1	1.5
2	1.7
3	2
4	3

For Model S (YBD022/YAZ318)

Detected IDU units	Total Detected IDU Code (Sum of IDU code)	
	Minimum Allowed	Maximum Allowed
3	2	4.5

Whenever the sum of the IDU code is outside the range the unit will be forced to Idle Mode and report: *“Mismatch between IDU and ODU models”*.

If the unit is forced to Idle Mode, then it will keep checking this condition (the indoor total capacity test) in order to prevent system latch up. Once the condition is fine, the fault will be cleared and the unit will proceed to normal operation.

11.3.1.1.3 Model Plug & Indoor Capacity Test

This test is performed for both single split channel and multi split channel:

Test	How to check?	Error to report?	System Action (ODU Mode)
Jumper is inserted/DIP is configured	ODU model is 0 (zero).	"Missing ODU configuration"	Force to Idle mode.
Jumper/DIP is not defined in the software	ODU model is not Q.	"Undefined ODU model"	Force to Idle mode
IDU-ODU capacity group mismatch	When ODU model is Q, <u>and</u> the capacity group is not allowed.	"Mismatch between IDU and ODU models "	Except for ITU mode, Force to Idle mode

The following combinations show the allowed and not allowed capacity group:

ODU Model	Communication channel	Is it allowed capacity group?				
		Indoor Capacity				
		0	1	2	3	4
S (YBD022/YAZ318)	Single- Non Hydro	No	No	No	Yes	No
	Single- Hydro	No	No	No	No	No
	Com Channel 1	Yes	Yes	No	No	No
	Com Channel 2	Yes	Yes	No	No	No
	Com Channel 3	No	No	No	No	No
	Com Channel 4	Yes	Yes	No	No	No

Notes

1. The outdoor will keep establishing normal communication with the indoor or DMSMP.
2. The outdoor will show diagnostics normally.
3. The SB LED will keep ON as long as the power is on.
4. Once the unit is forced to Idle due to either of the above, it will keep checking the above items, until the system is recovered.

11.3.2 Communication with Indoor Units

11.3.2.1 Communication Failures Definition

Two types of communication failures are diagnosed. The communication failures are checked separately for each IDU channel.

11.3.2.2 'Bad Communication' fault

The system keeps a balance of a good/bad communication packet ratio for each active communication channel. When the ratio getting high , system enters 'Bad Communication' fault.

11.3.2.3 'No Communication' fault

If no legal transmission or no message received for 30 seconds, system enters 'No Communication' fault.

When in 'No Communication' fault, the system will act as following:

- If there is no communication in all channels, the following will be performed:
 1. The unit changes to SB.
 2. The system will scan all the communication.

3. Each channel that is identified as 'no communication' channel will be referred as STBY unit.
4. The unit resumes its normal operation with only the operative channels.

11.3.3 Temperature Measurements

11.3.3.1 Thermistor failures definition

Thermistor	Type a – Disconnected	Type b – Shorted
OAT	Temp < -30 °C	Temp > 75 °C
OCT	Temp < -35C	Temp > 75 °C
CTT	Temp < -30 °C	Temp > 125 °C
HST	Temp < -30 °C	Temp> 125 °C
OMT	Temp < -35 °C	Temp > 75 °C
ICT	Temp < -30 °C	Temp > 75 °C
RGT	Temp < -30 °C	Temp > 126 °C
RLT	Temp < -30 °C	Temp > 126 °C

11.3.3.2 System responses for different thermistor failure

Thermistor	Default value	System Reaction
OCT	43°C	
OAT	6°C	
CTT	43°C	Compressor is stopped.
OMT	43°C	Compressor is stopped in cooling mode.
HST	43°C	Compressor is stopped.
RGT	43°C	
RLT	43°C	
ICT	43°C	

11.3.4 Flash Memory Programming

In order to upgrade the ODU software the auxiliary port will be used. A special application should be run on a PC to transmit the new firmware. Special programmer (Panasonic) should be used to update the S/W.

11.4 Indoor Unit Control

11.4.1 Indoor Fan Control

10 Indoor fan speeds are determined for each model. 5 speeds for each mode cool/dry/fan or heat.

When user sets the indoor fan speed to a fixed speed (Low/ Medium/ High), unit will operate constantly at set speed.

When Auto Fan is selected, indoor unit controller can operate in all speeds. The actual speed is set according to the cool/heat load.

Turbo Speed

The Turbo speed is activated during the first 30 minutes of unit operation when auto fan speed is selected and under the following conditions:

Difference between set point and actual room temperature is higher than 3 degrees.

Room temperature is higher than 22°C for cooling or less than 25°C for heating.

11.4.2 Cool Mode

NLOAD is calculated according to the difference between actual room temperature and user set point temperature by PI control.

In high/ medium/ low indoor fan user setting, unit will operate fan in selected speed.

In Auto Fan user setting, fan speed will be adjusted automatically according to the calculated NLOAD.

11.4.3 Heat Mode

NLOAD is calculated according to the difference between actual room temperature and user set point temperature by PI control.

In high/ medium/ low indoor fan user setting, unit will operate fan in selected speed.

In Auto Fan user setting, fan speed will be adjusted automatically according to the calculated NLOAD.

11.4.3.1 Temperature Compensation

In wall mounted, ducted, and cassette models, 3 degrees are reduced from room temperature reading (except when in I-Feel mode), to compensate for temperature difference between high and low areas in the heated room, and for coil heat radiation on room thermistor.

The temperature compensation can be enabled/disabled by shortening of J2 on the indoor unit controller.

Model	J2 Shorted	J2 Opened
Wall mounted	Compensation Disabled	Compensation Enabled
Cassette	Compensation Enabled	Compensation Disabled
Ducted	Compensation Enabled	Compensation Disabled
Floor/Ceiling	Compensation Disabled	Compensation Enabled

11.4.3.2 Indoor Fan Control in Heat Mode

Indoor fan speed depends on the indoor coil temperature:

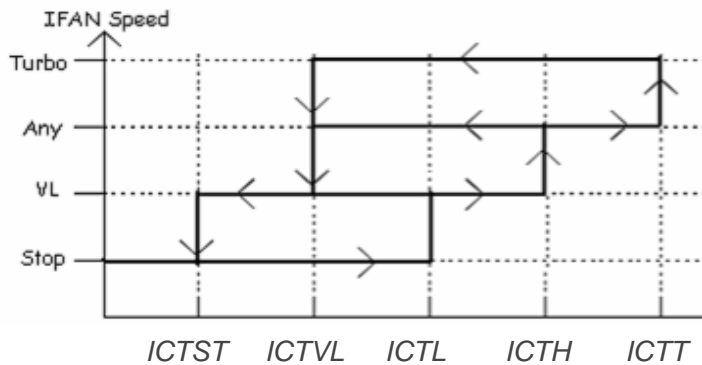

11.4.4 Auto Cool/Heat Mode

When in auto cool heat mode unit will automatically select between cool and heat mode according to the difference between actual room temperature and user set point temperature (ΔT).

Unit will switch from cool to heat when compressor is off for 3 minutes, and $\Delta T < -3$.

Unit will switch from heat to cool when compressor is off for 5 minutes, and $\Delta T < -3$.

11.4.5 Dry Mode

As long as room temperature is higher than the set point, indoor fan will work in low speed and compressor will work between 0 and *MaxNLOADIF1C* Hz.

When the room temperature is lower than the set point, compressor will be switched OFF and indoor fan will cycle 3 minutes OFF, 1 minute ON.

11.4.6 Indoor Units Operation when Indoor Unit Mode is Different than Outdoor Unit Mode

- Open louvers according to user selection.
- Indoor fan is forced to OFF.

11.4.7 Indoor Unit Dry Contact

Indoor unit Dry contact has two alternative functions that are selected by J9.

Status	Function	Contact = Open	Contact = Short
J9 = Open	Presence Detector Connection	No Limit	Forced to STBY
J9 = Short	Power Shedding Function	No Limit	Limit NLOAD

11.4.8 Operating the Unit from the Mode Button

Forced operation allows starting, stopping and operating in Cooling or Heating, in pre-set temperature according to the following table:

Forced operation Mode	Pre-set Temperature
Cooling	20 ^o C
Heating	28 ^o C

11.4.9 On Unit Controls and Indicators

11.4.9.1 All Models Except for Floor/Ceiling model

STAND BY INDICATOR	Lights up when the Air Conditioner is connected to power and ready to receive the R/C commands
OPERATION INDICATOR	Lights up during operation. Blinks for 300 msec to announce that a R/C infrared signal has been received and stored. Blinks continuously during protections (according to the relevant spec section).
TIMER INDICATOR	Lights up during Timer and Sleep operation.
FILTER INDICATOR	Lights up when Air Filter needs to be cleaned.
COOLING INDICATOR	Lights up when system is switched to Cool Mode by using the Mode Switch <u>on the unit</u> .
HEATING INDICATOR	Lights up when system is switched Heat Mode by using the Mode Switch <u>on the unit</u> .
Mode SWITCH (COOL/HEAT/OFF)	Every short pressing , the next operation mode is selected, in this order : SB → Cool Mode → Heat Mode → SB → ... In long pressing system enters diagnostic mode.
RESET / FILTER SWITCH	For short pressing: When Filter LED is on - turn off the FILTER INDICATOR after a clean filter has been reinstalled. When Filter LED is off – enable/disable the buzzer announcer, if selected.

11.4.9.2 Floor/Ceiling Model

STANDBY INDICATOR	Lights up when the Air Conditioner is connected to power and is ready for operation
OPERATE INDICATOR	1. Lights up during operation. 2. Blinks for 300 msec to announce that a R/C infrared signal has been received and stored. 3. Blinks continuously during protections (according to the relevant spec section).
TIMER INDICATOR	Lights up during Timer and Sleep operation.
FILTER INDICATOR	1. Lights up when Air Filter needs to be cleaned. 2. Blinks during Water Over Flow in PXD models. (Cf. Sect. 7.3)
COOLING INDICATOR	Lights up when system is switched to Cool Mode by using the Mode Switch <u>on the unit</u> .
HEATING INDICATOR	Lights up when system is switched Heat Mode by using the Mode Switch <u>on the unit</u> .
FAN MODE INDICATOR	Lights up in Fan Mode activated by <u>local switches</u> .
FAN SPEED INDICATORS	L -- Lights up when IFAN setting is Low. M -- Lights up when IFAN setting is Medium. H -- Lights up when IFAN setting is High. A -- Lights up when IFAN setting is Auto.
TEMP. SETTING INDICATORS	Each one of the seven indicators indicates the following SPT: 18, 20, 22, 24, 26, 28, 30 [°c]. The odd number temperatures are indicated by turning on the two adjacent indicators.
FAN SPEED BUTTON	Press this button to change the speed of the IFAN. Each pressing change the speed in the sequence of: ... L → M → H → Auto → L → ...
TEMP. SETTING UP BUTTON	Pressing this button increases the SPT by 1°c. Note: The Max SPT is 30°c.

TEMP. SETTING DOWN BUTTON	Pressing this button decreases the SPT by 1°C. Note: The Min SPT is 18°C.
MODE BUTTON	Every short pressing, the next operation mode is selected, in this order: SB → Cool Mode → Heat Mode → SB → ... In long pressing system enters diagnostic mode.
POWER BUTTON	Toggle the unit between OPER & STBY modes.
RESET / FILTER BUTTON	For short pressing: When Filter LED is on - turn off the FILTER INDICATOR after a clean filter has been reinstalled. When Filter LED is off – enable/disable the buzzer announcer, if selected. In long pressing system enters set up mode (if in SB).

11.5 Run Mode

Run mode is the default operation mode of the system. This is the standard operation mode that is active in field application (at customer site).

System can go from run mode to other operation modes through keyboard or serial ports.

11.5.1 Mode Setting

Mode defines the ODU operation mode. There are three possible operation modes:

STBY – standby mode

COOL - the unit operating at cooling cycle

HEAT - the unit operating at heat pump cycle

The ODU define the system operation mode according to three methods set by the display key board:

11.5.1.1 First request priority

The first IDU which requests different mode than STBY mode will set the new operation mode.

The mode will change once all the units exit the current operation mode.

11.5.1.2 Priority unit

If an IDU is defined as a priority unit, the operational mode will be defined according to that unit request, unless the unit is at STBY mode.

In case priority unit is SB, the mode will be set according to first request priority.

11.5.1.3 Forced operation mode

If forced mode is enabled than the ODU mode will be forced according to the Forced mode input:

Open → COOL

Short → HEAT

The ODU will go to SB if all the IDU are at SB or at different modes.

11.5.1.4 SB Input

The ODU will change mode between COOL/HEAT and Idle according to the STBY dry contact input as follows:

STBY input	ODU mode
Short	SB
Short → Open	last mode
Open	according normal mode selection

11.5.2 Compressor Speed Control

11.5.2.1 Compressor Min On/Off time

Compressor minimum OFF time is MinOFFTime minutes except during Deicing protection.

Compressor minimum ON time is MinOnTime minutes, minimum ON time is ignored during protections, and when unit is turned to STBY.

11.5.2.2 Compressor Speed calculation

During normal operation (excluding protections), the compressor speed is limited by the following table:

Min Speed Cool (check)	Max Speed Cool	Min Speed Heat	Max Speed Heat
20	90	20	90

11.5.2.3 Indoor Units NLOAD calculation

The NLOAD setting is done by the indoor unit controller, based on a PI control scheme. The actual NLOAD to be sent to the outdoor unit controller is based on the preliminary LOAD calculation, the indoor fan speed, and the power shedding function.

NLOAD limits as a function of indoor fan speed:

Indoor Fan Speed	Maximum NLOAD Cooling	Maximum NLOAD Heating
Low	Max NLOADIF1C	127
Medium	Max NLOADIF2C	127
High	Max NLOADIF3C	127
Turbo	Max NLOADIF4C	127
Auto	Max NLOADIF5C	127

NLOAD limits as a function of power shedding:

Mode	Power Shedding OFF	Power Shedding ON
Cool	No limit	Nominal Cooling
Heat	No limit	Nominal Heating

11.5.2.4 Outdoor Unit NLOAD calculation

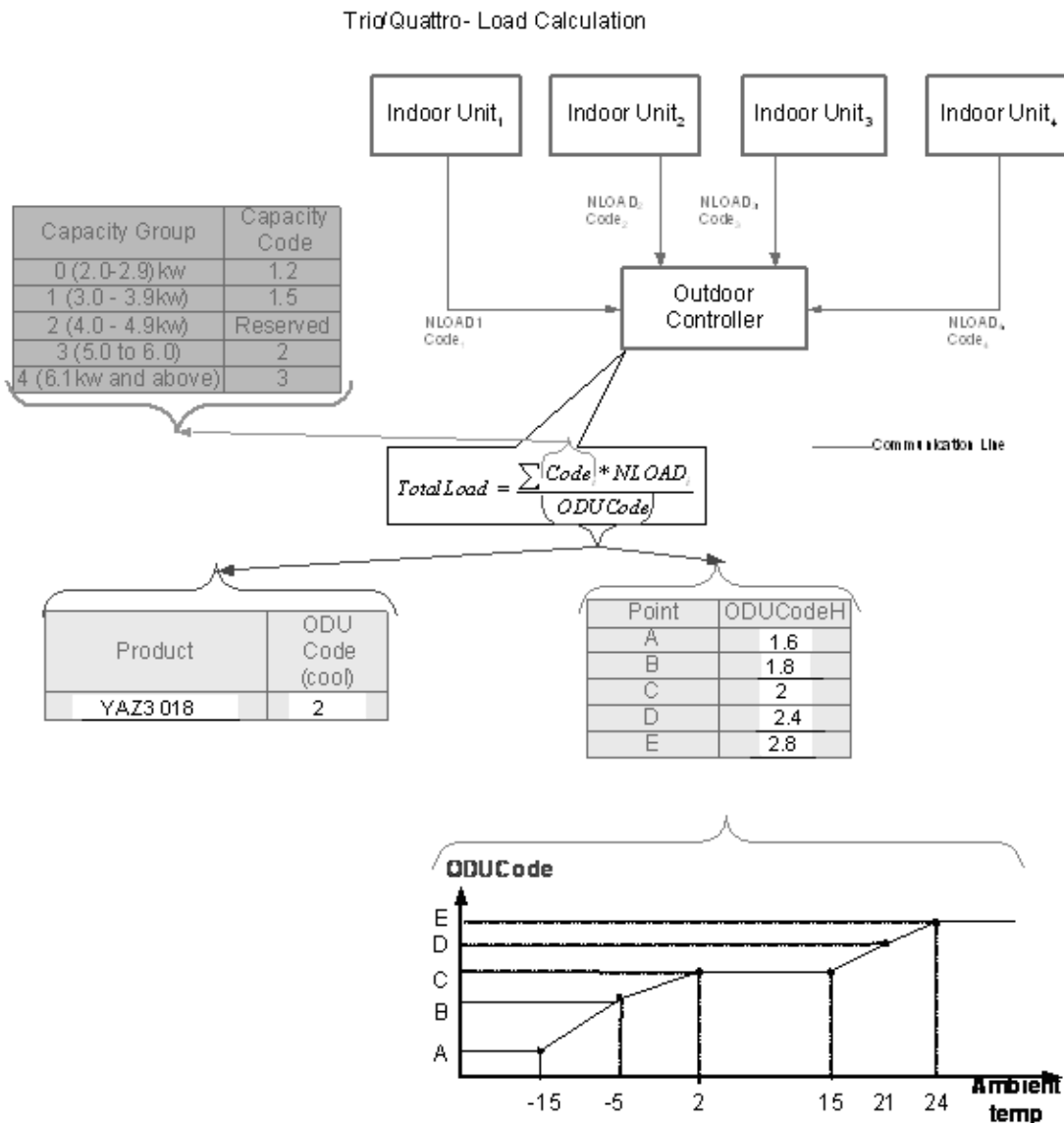

Compressor speed will be set between the minimum speed and the max speed according to the ODU NLOAD

11.5.2.5 Speed Step Limitations

11.5.2.5.1 Step 1 and step 2

The compressor speed cannot go below *Step1Freq* or above *Step2Freq* during 3 continuous minutes once after the compressor starts up when the ODU unit changes from STBY

11.5.2.5.2 Step 3 limit

The speed cannot go higher than *Step3Freq* unless it was operating for more than 1 continuous minute between *Step3Freq - 5* and *Step3Freq*.

11.5.3 EEV Control

11.5.3.1 Operation Range

The EEV operation range is defined according to the operation mode as following

ODU Mode	Normal operation	IDU inactive	Compressor off
SB	400		400
COOL	50 to 480	0	
HEAT	50 to 480	50 to 120	

11.5.3.2 Reaching target value rules

For all cases except at EEV initialization procedure, each EEV can move no more than 20 steps at a time.

When required the EEV's move, one by one in sequence, until the target position is achieved for every EEV.

The following diagram presents the EEV steps until the target position is set.

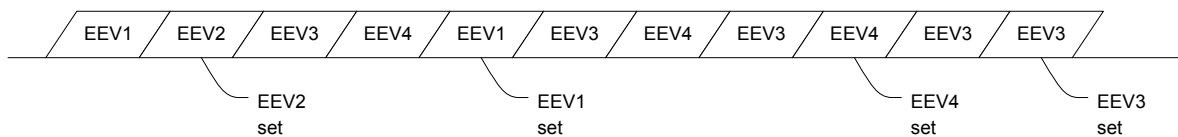

11.5.3.3 EEV homing

When compressor stops or unit is power on, the following is performed immediately:

- All EEV's are set to 400.
- They remain in this position for 80 Sec.
- Then, close to 60 steps below 0 to ensure full closure, then proceed to normal operation

11.5.3.4 EEV Opening Determination

The target EEV value is the sum of open loop value (OL) and a result of the accumulative correction values (CV).

$$EEV_i = EEV_{OLi} + \sum EEV_{CVi}$$

EEV_i is the EEV opening for each 'i' IDU.

11.5.3.5 EEV initial value determination

The EEV initial value (open loop) is determined according to the number of the active indoor units, mode, and the capacity code of the unit.

11.5.3.6 Balance time

During the first 5 minutes after SB, the correction is not calculated. After that, the correction value is updated every 30 seconds.

11.5.3.7 EEV corrections

The corrections in cool mode will keep the compressor in the proper operation temperature and will balance between the indoor units by controlling their super heat.

11.5.3.8 Accumulative correction value storage

For each combination of active IDUs, the accumulated EEV correction value (for each IDU) will be stored in the memory. Default correction values after power up are zero.

11.5.4 Outdoor Fan Speed Control

The OFAN operation keeps the outdoor heat exchanger temperature within a predefined values by increasing or reducing the OFAN speed. Whenever the OFAN speed is abnormal, the OMT and OCT sensors need to be checked.

11.5.4.1 Behavior when there is a failure in OFAN

Whenever OFAN fault occurs, the compressor will be stopped immediately.

11.5.4.2 Protection Behavior

- In cool mode the OFAN will operate according to CTT or HST protection level:

Protection level	Action
SR, D1 or D2	OFAN will go to the Max. speed
Stop-Compressor	Continue to operate for maximum 3 minutes at 500 rpm or until normal level is achieved.

11.5.4.3 OFAN Force On condition

If HST is faulty, OFAN will continue to operate for 3 minutes at 500 rpm after COMP is OFF.

11.5.4.4 Night mode

Upon receiving night mode, the OFAN will be limited to max *NightRPM* speed only in Cool. It will be back to its normal operation when receiving the mode is cleared.

11.5.5 RV State Setting

During heat mode (except during Deicing) RV is ON.

During cool/SB mode, RV is OFF.

RV status will be changed only if COMP is OFF for 3 minutes or more.

11.5.6 Base Heater Setting

Base heater should be ON when unit is in heating and according to the below graph.

If OAT is disconnected, Base heater will be ON when unit is in heating.

Base Heater at heating mode

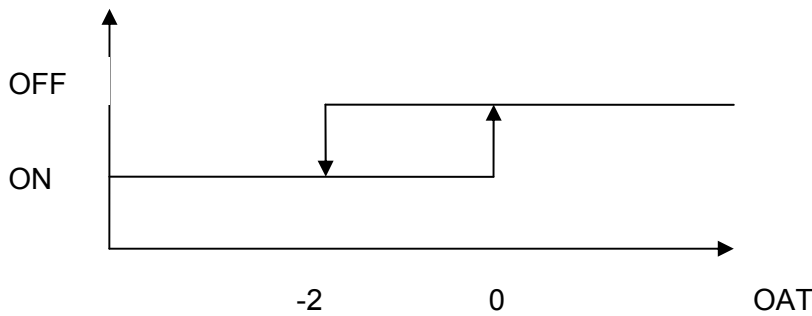

Note: 'On' state has higher priority.

11.5.7 Thermodynamic Protections

Protection level definition

- Five protection levels are defined:
- Normal – No protection status is ON.
- Stop-Rise (SR) – System is in protection, first level
- D1 - System is in protection, second level
- D2 - System is in protection third level
- Stop-Compressor (SC) – System is in protection fourth level

11.5.8 IDU Protection Level

The overall protection level of the indoor units will be the worst protection status among the all indoor units.

11.5.9 IDU Protections

11.5.9.1 Indoor Coil Defrost Protection

ICT	ICT Trend				
	Fast Increasing	Increasing	No change	Decreasing	Fast Decreasing
ICT < -2	SC	SC	SC	SC	SC
-2 ≤ ICT < 0	D1	D1	D2	D2	D2
0 ≤ ICT < 2	SR	SR	D1	D2	D2
2 ≤ ICT < 4	SR	SR	SR	D1	D2
4 ≤ ICT < 6	Norm	Norm	SR	SR	D1
6 ≤ ICT < 8	Norm	Norm	Norm	SR	SR
8 ≤ ICT	Normal				

11.5.9.2 Indoor Coil over Heating Protection

ICT	ICT Trend				
	Fast Decreasing	Decreasing	No Change	Increasing	Fast Increasing
ICT > 55	SC	SC	SC	SC	SC
53 < ICT ≤ 55	D1	D1	D2	D2	D2
49 < ICT ≤ 53	SR	SR	D1	D2	D2
47 < ICT ≤ 49	SR	SR	SR	D1	D2
45 < ICT ≤ 47	Norm	Norm	SR	SR	D1
43 < ICT ≤ 45	Norm	Norm	Norm	SR	SR
ICT ≤ 43	Normal				

11.5.10 ODU Protections

There are 3 ODU protections:

- Compressor overheating
- Heat sink overheating
- System over power

Operation logic of all protections is the same. The controlled input (CTT, HST, or PWR) is controlled by changing the protection level using the fuzzy logic algorithm according the input level and the change rate.

There are two sets of POWER values, the selection of the values are set according to the state of the Power-Shed dry contact input.

Power-Shed input open → Power1

Power-Shed input sort → Power2

The following table summarizes the basic levels of each protection.

Protection level	Comp Overheat (CTT)	Heat Sink (HST)	Power1	Power2
Stop compressor	105	84	2800	2100
Down 2	100	80	2650	1988
Down 1	95	77	2500	1875
Stop rise	90	74	2350	1763
Normal	85	71	2350	1763

11.5.10.1 Total Protection Level Definition

The total protection level is defined by the higher level of protection received.

11.5.11 Deicing

11.5.11.1 Deicing Starting Conditions

Deicing operation will start when either one of the following conditions exist:

Case 1: $OCT < OAT - DST$ AND $TLD > DI$

Case 2: $OCT < OAT - 12$ AND $TLD > 30$ minutes.

Case 3: OCT is Invalid AND $TLD > DI$

Case 4: Unit is just switched to STBY AND $OCT < OAT - DST$

Case 5: $NLOAD = 0$ AND $OCT < OAT - DST$

Case 6: OAT is invalid AND $OCT < DST$ AND $TLD > DI$ AND Compressor ON Time $> CTMR$ minutes

OCT – Outdoor Coil Temperature

OAT – Outdoor Air Temperature

TLD – Time from Last Deicing

DI – Deicing Interval (Time Interval between Two Deicing)

DST – Deicing static threshold (Temperature)

Deicing interval time when compressor is first started in heat mode, is 10 minutes if $OCT < -2$, and is 40 minutes in other cases.

Deicing interval time is changed (increased/ decreased in 10 minutes steps) as a function of deicing time. If deicing time is shorter then former deicing time, the deicing interval time will be increased. If deicing time is longer then former deicing time, the deicing interval time will be decreased.

11.5.11.2 Deicing Protection Procedure

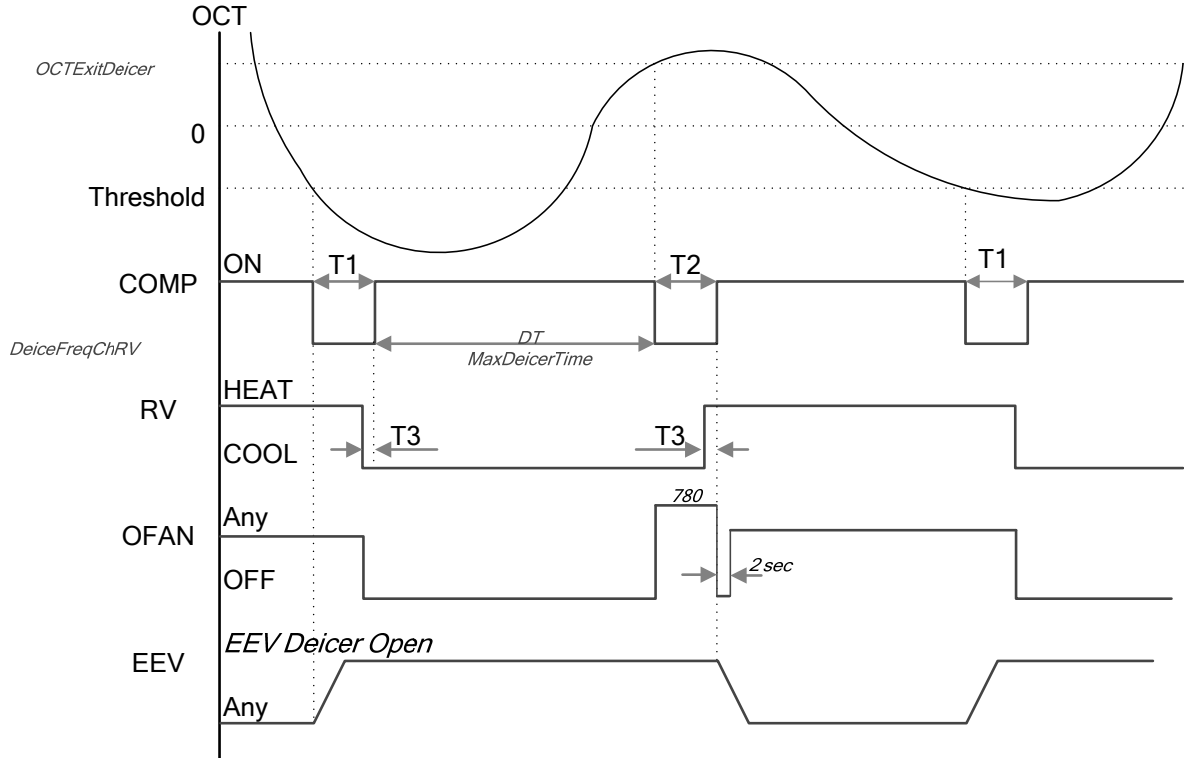

T1 = T2 = 36 seconds, T3 = 6 seconds

11.5.11.3 Condensate Water over Flow Protection

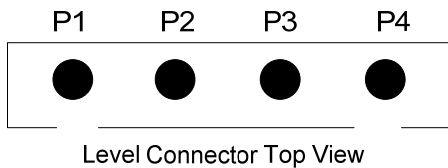

Each of the pins P1, P2, P3 can have two options:
 1 – When it is shorted with P4
 0 – When it is not shorted to P4

11.5.11.4 3 Levels Logic (used in floor/ceiling models)

P2	P3	Level
0	0	L0
1	0	L1
1	1	L2&3
0	1	L4

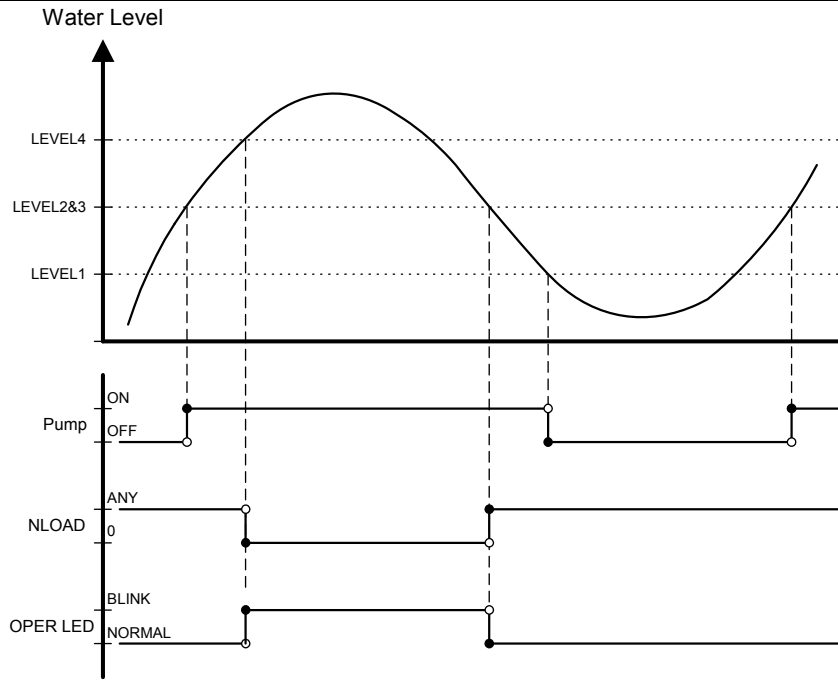

11.5.11.5 1 Level Logic (used in all models except for floor/ceiling models)

P2	P3	Level
Don't care	1	Normal
Don't care	0	Overflow

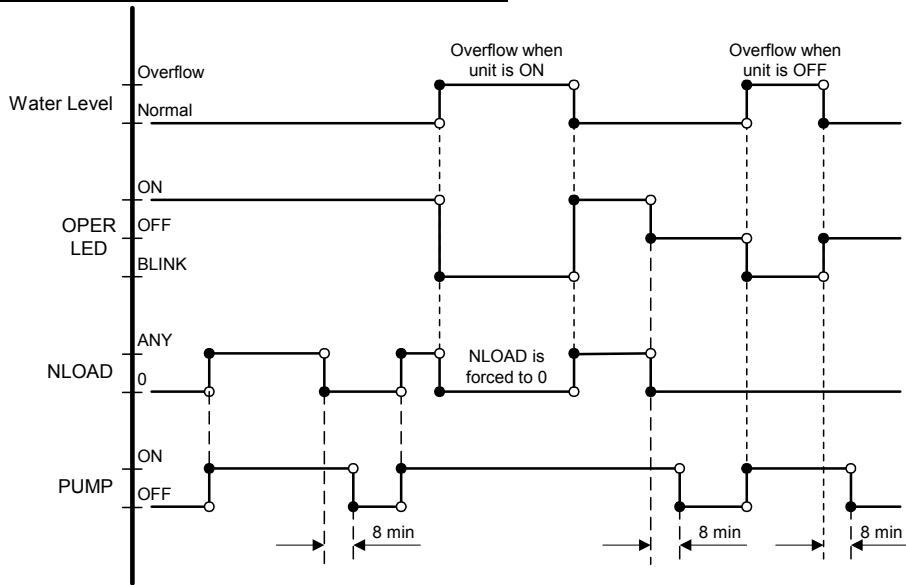

11.6 Installation Test Mode

11.6.1 Test Objectives

- Find tube-communication wires mismatch.
- Instruct the technician to match the tubes to the communication wires.
- Find EEV or tubing problems.

11.6.2 Test Concept

- The unit will open each EEV separately in cooling mode.
- Detect a temperature drop on the indoor unit.
- Based on the temperature drop, the system can match the tube to the indoor unit.

11.6.3 Test Rules

Before starting the installation/technician test, make sure for the following:

1. No indoor communication channel is connected to non existing tube channel.
2. The number of the connected/installed indoor unit is set properly.
3. All the EEVs are connected properly to the right EEV channels.
4. No mix between the indoor unit's tubes, each indoor unit must have its own tubes connected properly to the outdoor unit.

If the rules above are not respected, the test results will make no sense.

11.6.4 Installation test menu

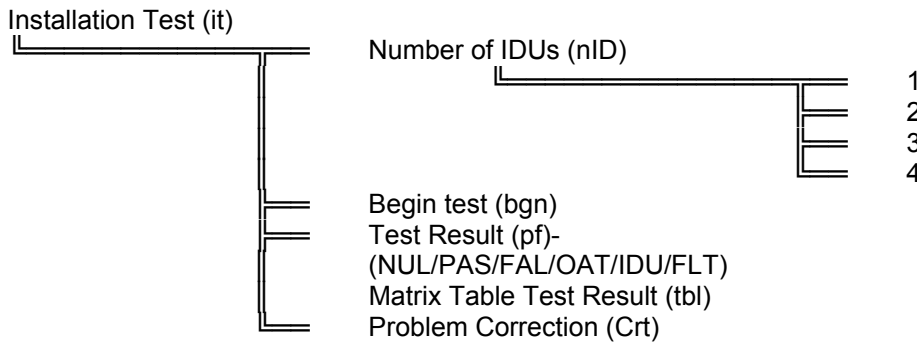

11.6.5 How to do installation test

1. While the power is off, set the following labels on the wires:

On unit Label	C _A	C _B	(C _C)	(C _D)
Wire name (Marked by technician)	1	2	3	4
For non connected indoor units, there is no need for label.				

2. Set the number of the connected/installed indoor units.
Elect 'nID' number under 'it', the selected number blinks. The factory setting value is 4.
3. Enter installation test (by either of the following):
 - a. Select 'bgn' under 'it' menu.
 - b. According to the following:

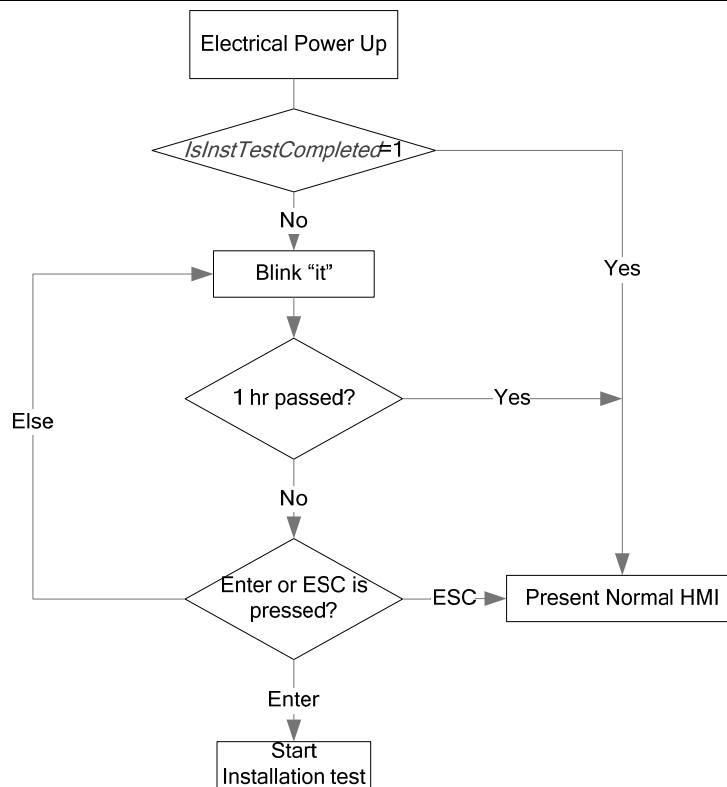

4. During the test, the unit will show count down counter (in minutes). The test maximum time is 20 minutes.
5. When the test is finished, the system will show the test result, pass or fail.
6. You can scroll the menu to observe:
 - a. Observe the matrix result
 - b. Guide for problem correction.
7. For fixing problem, copy on paper the results displayed results, power off the unit, and then fix the problem accordingly. Do not do any wire fixing under power!

Note:

You can exit the installation test any moment by pressing Esc for 5 seconds. When exiting the test, the system will still keep the latest result from the previous test.

11.6.6 Faults during the test

Upon the following, the system will terminate installation test:

Fault (display)	Reasons
'OAT' blink	Outdoor ambient temperature is too clod, cannot run installation test.
'IDU' blink	The selected number of the installed indoor units by the technician does not match the number of indoor units detected by the system.
Display indoor or outdoor fault as in diagnostics	Check indoor and outdoor diagnostics. ICT disconnected will be tested during the first 3 minutes of installation test.

Note: When the system terminates the tests due to the problem above, the matrix results will present partial test.

How to interpret the results (pf sub menu):

Test Result (pf)	Interpretation
NUL	The test has never been done before.
PAS	The test is pass
FAL	The test is fail
OAT	Outdoor air temperature is lower than 5 degrees. The installation test cannot be done.
IDU	The selected number of the installed indoor units by the technician does not match the number of indoor units detected by the system.
FLT	IDU or ODU fault

11.6.7 Matrix Table Test Result (tbl) & Problem Correction (Crt)

The technician has to use labels on the indoor wires connected to the outdoor

On unit Label	C _A	C _B	(C _C)	(C _D)
x=Wire name (Marked by technician)	1	2	3	4
For non connected indoor units, there is no need for label.				

The result is presented in the following way:

Present for 2 sec	Present for 2 Sec.	Interpretation
x--:	Cz	'x' is the wire name (1,2,3,4) 'z' is the communication channel (A,b,c,d) 'x--:Cz' is move wire 'x' to communication channel Cz
Ey-:	W	'y' is the EEV channel name (A,b,c,d) 'w' can be: 1. 'c' is closed 2. 'o' is open 3. 'oc' is either close or open.
x--:	C_	'x' is the wire name (1,2,3,4) 'C_' is unknown communication channel. 'x--:C_' is the system does not know where to move wire 'x'.

Possible reasons for 'o' and 'c':

Term	Possible reasons
'c'	<ul style="list-style-type: none"> • Clogged EEV • EEV Coil problem • EEV driver problem • Clogged indoor unit or part of it. • Problem in ICT sensor • Extremely high load at the indoor side
'o'	<ul style="list-style-type: none"> • Valve always open • EEV coil problem • Driver Problem

Examples:

#			Problem Correction (Crt)	
1,2	HMI Display	Technician Interpretation	HMI Display	Technician Interpretation
	2--:Cb	Keep wire 2 on communication channel C _B .	1--:CA	Keep wire 1 inside communication channel C _A
	3--:Cc	Keep Wire 3 on communication channel C _C	2--:Cb	Keep wire 2 inside communication channel C _B
	1--:Cd	Move wire 1 to communication channel C _D	3--:Cc	keep wire 3 inside communication channel C _C
	4--:CA	Move Wire 4 to communication channel C _A	4--:Cd	Keep wire 4 inside communication channel C _D .
3,4	HMI Display	Technician Interpretation	HMI Display	Technician Interpretation
	1--:Cb	Move wire 1 to communication channel C _B	4--:Cd	Keep wire 4 to communication channel C _D
	2--:CA	Move wire 2 to communication channel C _A	1--:Cb	Move wire 1 to communication channel C _B
			2--:CA	Move wire 2 to communication channel C _A
5,6	HMI Display	Technician Interpretation	HMI Display	Technician Interpretation
	4--:Cd	keep wire 4 in communication channel C _D	1--:Cd	Move wire 1 to communication channel Cd
	1--:Cb	Move wire 1 to communication channel C _B	2--:Cc	Move wire 2 to communication channel Cc
	2--:Cc	Move wire 2 to communication Channel C _C	3--:C ₋	Do not know where to put wire 3
	3--:CA	Move wire3 to communication Channel C _A	4--:C ₋	Do not know where to put wire 4
	EA:o	EEV of channel A is always open	EA:o	EEV of channel A is always open
		Eb:o	EEV of channel B is always open	
7,8	HMI Display	Technician Interpretation	HMI Display	Technician Interpretation
	1--:CA	Keep wire 1 in communication channel CA	2--:Cc	Move wire 2 to communication Channel Cc
	2--:Cb	Keep wire 2 in communication channel Cb	3--:CA	Move wire 3 to communication Channel CA
	3--:Cd	Move wire 3 to communication channel Cd	1--:C ₋	Do not know where to put wire 1
	4--:Cc	Move wire 4 to communication channel Cc	4--:C ₋	Do not know where to put wire 4
	Ec:c	EEV of channel C is always close	Eb:c	EEV of channel B is always close
			Ed:c	EEV of channel D is always close
9,10	HMI Display	Technician Interpretation	HMI Display	Technician Interpretation
	4--:Cd	Keep wire 4 in communication channel Cd	3--:Cc	Keep wire 3 in communication channel Cc
	2--:Cc	Move wire 2 to communication channel Cc	4--:Cd	Keep wire 4 in communication channel Cd
	1--:C ₋	Do not know where to put wire 1	1--:CA	Move wire 1 to communication channel CA
	3--:C ₋	Do not know where to put wire 3	EA:O	EEV in channel A is always open
	EA:Oc	EEV in channel A can be open or close		
	EB:Oc	EEV in channel B can be open or close		

11.6.8 Matrix Table Test Result (tbl)

		IDU channels on the DMSMP			
		Channel1 (j=1)	Channel2 (j=2)	Channel3 (j=3)	Channel4 (j=4)
EEV channels on the DMSMP	EEV1 (i=1)	X ₁ =T/F/N/C	Y ₁ =T/F/N/C	Z ₁ =T/F/N/C	W ₁ =T/F/N/C
	EEV2 (i=2)	X ₂ =T/F/N/C	Y ₂ =T/F/N/C	Z ₂ =T/F/N/C	W ₂ =T/F/N/C
	EEV3 (i=3)	X ₃ =T/F/N/C	Y ₃ =T/F/N/C	Z ₃ =T/F/N/C	W ₃ =T/F/N/C
	EEV4 (i=4)	X ₄ =T/F/N/C	Y ₄ =T/F/N/C	Z ₄ =T/F/N/C	W ₄ =T/F/N/C

Stored Matrix Type [Rows, Column]	How to present?
2 x 2	Repeat: r1(keep 2 sec)→ X1Y1 (keep 2 sec)
	Repeat: r2 (keep 2 sec) → X2Y2 → (keep 2 sec)
3 x 3	Repeat: r1 (keep 2 sec) → X1Y1Z1 (keep 2 sec)
	Repeat: r2 (keep 2 sec) → X2Y2Z2 (keep 2 sec)
	Repeat: r3 (keep 2 sec) → X3Y3Z3 (keep 2 sec)
4 x 4	Repeat: r1 (keep 2 sec) → X1Y1Z1 (keep 2 sec) → W1 (keep 2 sec)
	Repeat: r2 (keep 2 sec) → X2Y2Z2 (keep 2 sec) → W2 (keep 2 sec)
	Repeat: r3 (keep 2 sec) → X3Y3Z3 (keep 2 sec) → W3 (keep 2 sec)
	Repeat: r4 (keep 2 sec) → X4Y4Z4 (keep 2 sec) → W4 (keep 2 sec)

Note: Scrolling between r1, r2, r3, and r4 is done through the ‘Up’ and ‘Down’ buttons

Definitions

Term	Definition
‘F’	Clogged EEV EEV Coil problem EEV driver problem Clogged indoor unit or part of it. Problem in ICT sensor Extremely high load at the indoor side
‘T’	Valve always open EEV coil problem Driver Problem
C	Non detected channel
N	Null- never done before

11.7 Technician Test Mode

This test is aimed for the technicians to check the system under a preset compressor and outdoor fan values while the expansion valves will function according to the normal running mode.

11.7.1 Entering technician mode

- This mode is entered through the outdoor unit using the HMI (refer to user interface section).
- It can be selected either for cool or heat.
- Technician test is not possible to enter during deicer.

11.7.2 Technician mode procedure

- All the connected indoor units will enter technician test at high indoor fan speed.
- The outdoor unit will be working normally (according to the run mode control logic) except the following changes:
 - The dry contacts inputs will be ignored.
 - Protections will be operative for stop compressor (not to be implemented in the current version).
 - The compressor and the outdoor fan will be working in target preset values according to the following table:

Technician Test			
Unit	Compressor Speed		OFAN speed
	Cool	Heat	
YAZ318	63	80	810rpm

11.7.3 Exiting technician mode

Technician mode will be exited either when:

- Escaping by the HMI (exiting the ttC or ttH menus)
- 60 minutes are passed from entering

11.8 User Interface

11.8.1 User interface description

- The user interface uses three 7 segments, and 4 keys.
- Keys, The 4 keys are:
 - Scroll - used to scroll between options (up and down)
 - Select - use to select an option
 - Escape - Will go up one level in the menu
- The user interface concept is Tree menus.
- Active selection or status will be indicated by blinking the display.

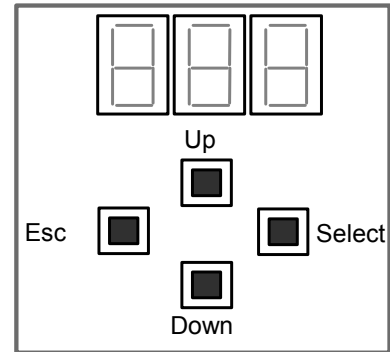

For YAZ218, The navigation through the menu can be performed by either the keypad or RC8 remote controller (through infra red receiver).

Command Type	Function	Keypad	Remote controller	RC8 sketch:
Up or Down command	Scrolling among options (up and down).	Up or Down key button.	Up: Set Point '+' Down: Set Point '-'	<p>The RC8 sketch shows a rectangular device with a large LCD screen at the top. Below the screen is a row of four circular buttons labeled 'Oper', 'SPT-', 'SPT+', and 'FAN'. At the bottom of the device is a larger rounded rectangular area labeled 'Button Box'.</p>
Selection command	Go down one level in the menu or select an option.	Select button	FAN mode	
Escaping command	Go up one level in the menu	Escape button	Oper/STBY	
<p>Note: the buttons above are selected according to RC8 design (refer to RC8 specifications) for the technician convenient use.</p>				

11.8.2 Keys functionality

- Scrolling will be done whenever the button is pressed.
- When scrolling alpha values, if the scroll button is held in, the selection will change at the rate of one step per second.
- When changing/scrolling numeric value, if the scroll button is held in, the selection will change at the rate of one step per second. After 2 seconds, if the button continues to be held in, the rate of change will increase to 10 steps per second.
- The display will not roll over during selection (for example stop/Ode/Dia/Stp/Par/stop)

11.8.3 Menus

11.8.3.1 Main Menu

Default (refer to the note)		
Technician Test (tt)	Technician Test Cool (ttC)	
	Technician Test Cool (ttH)	
Installation Test (it)	Number of IDUs (nID)- <i>IDU_Numbers</i>	
		1
		2
		3
		4
	Begin test (bgn)	
	Test Result (pf)- <i>InstTestResult</i> (NUL/PAS/FAL/OAT/IDU/FLT)	
	Matrix Table Test Result (tbl) <i>InstTestMatrixResult</i>	
	Problem Correction (Crt)	
Diagnostics (dia)	Outdoor Unit (o)	Outdoor Unit (oxx)
	Indoor Unit A (a)	Indoor Unit A (axx)
	Indoor Unit B (b)	Indoor Unit B (bxx)
	Indoor Unit C (c)	Indoor Unit C (cxx)
	Indoor Unit D (d)	Indoor Unit D (dxx)
Set Up (Stp)	First IDU Wins (idu)	
	DU A is master (a-p)	
	DU B is master (b-p)	
	DU C is master (c-p)	
	DU D is master (d-p)	
	Forced mode' input (Frc)	
Status (Stt)	IDU (IDU)	
	ODU (ODU)	
	Timer (Tr)	

Notes:

1. The default presentation will be alternating repeatedly among the following for single and multi split units:
 - o the mode of the unit (Cl/Ht/Sb) shown for 2 sec.
 - o ('id' + the number of communicative IDUs number) shown for 2 sec.
 - o Active fault (among ODU or IDUs), each to be shown for 2 sec.
2. In diagnostics menu:
 - o xx means failure code.

- Maximum 5 faults are presented for each unit (each IDUs/ODU). When no faults "-- sign will be shown.
 - The active faults have higher priority for presentation than non active ones.
 - Non active faults are presented according to their chronological order, starting from the latest one.
 - Whenever a new active fault occurs, it will be presented immediately.
 - Active faults are blinking, where non active ones do not.
3. The Status menu will be enabled to be presented and navigated, only by pressing select + escape together for more than 5 seconds under the main menu.
 4. Exiting 'Status' menu and its sub-menus back to the main menu is done by either pressing escape or after continuous 60 minutes out of any press.
 5. Technician Test mode, once is selected, is exited after 60 minutes from entry.
 6. All the menus, except Status and its sub-menu, Technician Test once selected, are automatically exited to the main menu after 10 continuous minute out of any press.
 7. When Technician test cool or heat menus are selected (operative), it will be blinking constantly until, this menu is escaped.
 8. When the installation test begins, the system will show up count down based (refer to the installation test. At the end of the installation test, the result will be presented.
 9. For the indoor diagnostics, whenever there is no-communication with indoor unit or indoor unit is not detected, 'no-communication' will be shown under the relevant indoor unit diagnostics. In addition to the indoor diagnostics, these faults will be also shown as well under the default show-
 10. When Alpha and numeric values are combined, they will be separated by dot.

11.8.3.2 Status (Sub Menu)

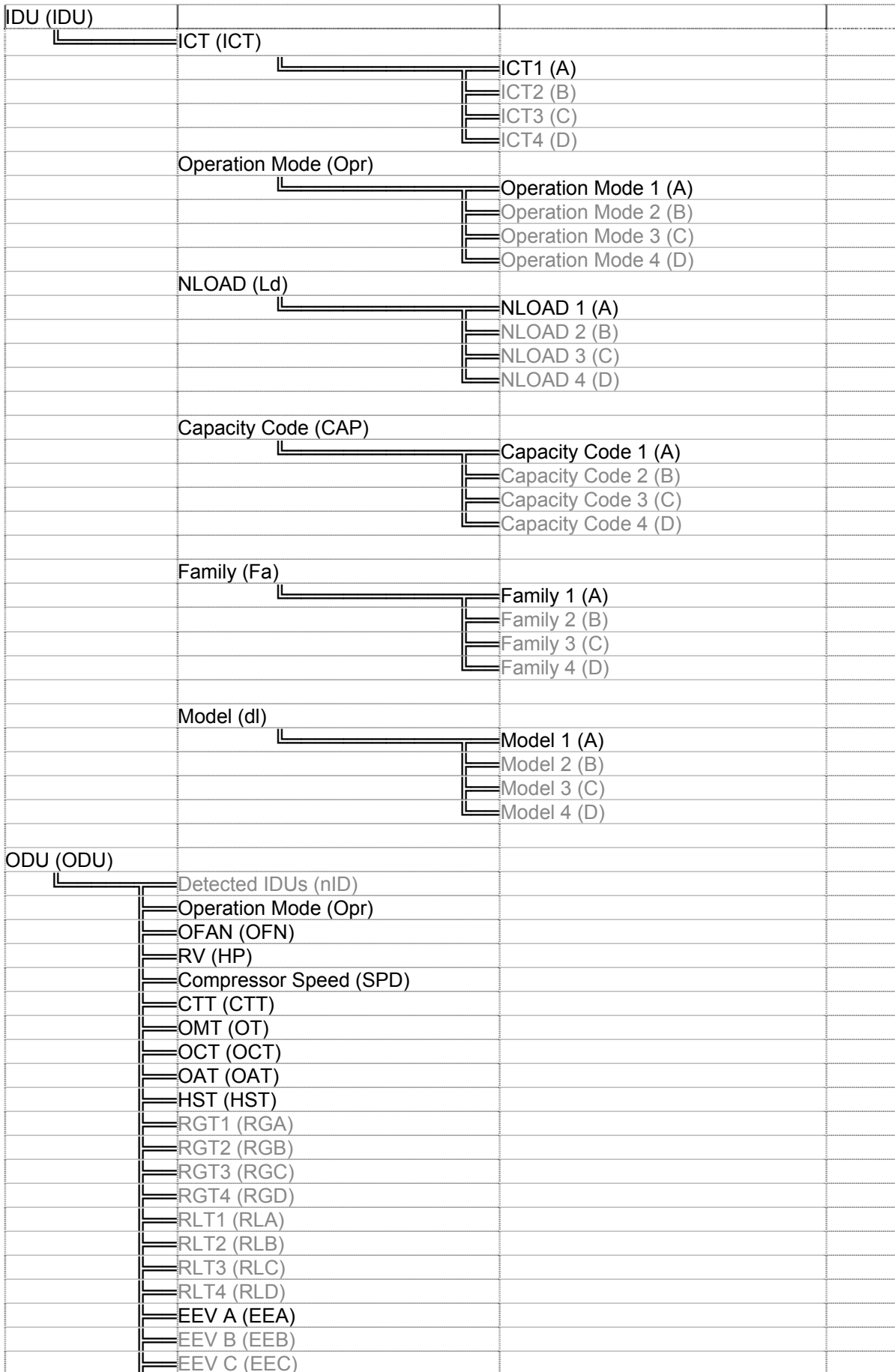

	EEV D (EED)		
	Power (Pr)		
	Current (Cur)		
	SW version (SOF)		
Timer (Tr)			
	Compressor Time (COP)		

Notes

- For the temperature display, when a thermistor is shorted, disconnected show FLT, when it's disabled show DIS.
- It is possible to present a number between 999 and 99,999 by alternating between two numbers (each number is presented for 1 second). The two numbers format is (off)xx, yyy.
- The compressor time is measured in hour's units.
- The modes: Cool, Heat, Dry, Fan Auto will be presented: CL, Ht, dr, FAn, AUt.
- The current is the AC current of the unit.
- The models A, b, C, and d will be presented -A-, -b-, -c-, and -d- respectively.

11.9 Jumper settings

ODU4	ODU3	ODU2	ODU1	ODU0	ODU Model	Compressor Type	
						Single Split	Multi Split
ON	OFF	OFF	OFF	OFF	P	Sanyo	Mitsubishi
ON	OFF	OFF	OFF	ON	Q	Panasonic	Panasonic
ON	OFF	OFF	ON	OFF	R		
ON	OFF	OFF	ON	ON	S	TOSHIBA	TOSHIBA
ON	OFF	ON	OFF	OFF	T		
ON	OFF	ON	OFF	ON	U		
ON	OFF	ON	ON	OFF	V		
ON	OFF	ON	ON	ON	W		
ON	ON	OFF	OFF	OFF	X		
ON	ON	OFF	OFF	ON	Y		
ON	ON	OFF	ON	OFF	Z		
ON	ON	OFF	ON	ON	AA		
ON	ON	ON	OFF	OFF	AB		
ON	ON	ON	OFF	ON	AC		
ON	ON	ON	ON	OFF	AD		
ON	ON	ON	ON	ON	AE		

11.10 System Parameters

11.10.1 General parameters

#	Name	Default Value	Units
1.	<i>MinOFFTime</i>	3	minute
2.	<i>MinONTime</i>	3	minute
3.	<i>HzUp_CTTOH</i>	2 / 60 / 8	Hz / Sec/NA
4.	<i>HzDown1_CTTOH</i>	-2 / 60 / 5	Hz / Sec/NA
5.	<i>HzDown2_CTTOH</i>	-4 / 60 / 3	Hz / Sec/NA
6.	<i>HzDown1_CCROC</i>	-1 / 2 / 1	Hz / Sec/NA
7.	<i>HzUp_CCROC</i>	1 / 30 / 7	Hz / Sec/NA
8.	<i>HzUp_ICTDef</i>	2 / 60 / 8	Hz / Sec/NA
9.	<i>HzDown1_ICTDef</i>	-3 / 60 / 4	Hz / Sec/NA
10.	<i>HzDown2_ICTDef</i>	-4 / 30 / 2	Hz / Sec/NA
11.	<i>HzUp_HSTOH</i>	2 / 60 / 8	Hz / Sec/NA
12.	<i>HzDown1_HSTOH</i>	-3 / 60 / 4	Hz / Sec/NA
13.	<i>HzDown2_HSTOH</i>	-4 / 30 / 2	Hz / Sec/NA
14.	<i>HzUp_ICTOH</i>	2 / 60 / 8	Hz / Sec/NA
15.	<i>HzDown1_ICTOH</i>	-3 / 60 / 4	Hz / Sec/NA
16.	<i>HzDown2_ICTOH</i>	-4 / 30 / 2	Hz / Sec/NA
17.	<i>HzUp_OMTOH</i>	2 / 60 / 8	Hz / Sec/NA
18.	<i>HzDown1_OMTOH</i>	-3 / 60 / 4	Hz / Sec/NA
19.	<i>HzDown2_OMTOH</i>	-4 / 30 / 2	Hz / Sec/NA
20.	<i>HzUp_OVRPWR</i>	1 / 30 / 7	Hz / Sec/NA
21.	<i>HzDown1_OVRPWR</i>	-1 / 2 / 1	Hz / Sec/NA
22.	<i>StopRise</i>	0 / 1 / 6	Hz / Sec/NA
23.	<i>DImin</i>	30	minute
24.	<i>DImax</i>	120	Minute
25.	<i>TimeD</i>	1	Minute
26.	<i>DTmin</i>	2	Minute
27.	<i>DIT</i>	10	Minute
28.	<i>CTMRUP</i>	10	Minute
29.	<i>DIF</i>	30	Minute
30.	<i>TCT</i>	240	Second
31.	<i>CompBalanceTimeA</i>	5	minute
32.	<i>IDUChngBalanceTime</i>	2	minute
33.	<i>CompBalanceTimeIA</i>	10	minute
34.	<i>DEICT1</i>	60	second

#	Name	Default Value	Units
35.	<i>DEICT2</i>	36	second
36.	<i>DEICT3</i>	6	second
37.	<i>DSTF</i>	12	°C
38.	<i>OMTOH0</i>	50	°C
39.	<i>OMTOH1</i>	53	°C
40.	<i>OMTOH2</i>	56	°C
41.	<i>OMTOH3</i>	59	°C
42.	<i>OMTOH4</i>	61	°C
43.	<i>OMTOH5</i>	63	°C
44.	<i>EEVLearning</i>	1	
45.	<i>EEVTimeSingleDSH</i>	30	second
46.	<i>EEVTimeSingleCTT</i>	40	second
47.	EEVTimeMultiSHC	30	second
48.	EEVTimeCTTProtection	60	second
49.	<i>EEVTimeSCProtection</i>	30	second
50.	<i>EEVTimeMultiDSHC</i>	30	second
51.	EEVTimeMultiCTT	30	second
52.	EEVTimeMultiSCH	30	second
53.	EEVTimeMultiDSHH	30	second
54.	<i>EEVTimeMultiFBH</i>	30	Second
55.	<i>InstTestIFANHighTime</i>	120	Second
56.	<i>InstTestIFANOffTime</i>	120	Second
57.	<i>InstTestDeltaICT</i>	15	°C
58.	<i>OATInstTst</i>	5	°C
59.	<i>PI_Time_Cnst</i>	50	Sec
60.	<i>EEVLogicType</i>	1	NA
61.	<i>MaxLWTHHeating</i>	59	°C

11.10.2 ODU Model Dependent Parameters

#	Name	S YAZ318	Unit
1.	MinFreqC	20	Hz
2.	MinFreqCA	40	Hz
3.	MaxFreqCSingle	90	Hz
4.	MaxFreqCMulti	90	Hz
5.	MinFreqH	20	Hz
6.	MinFreqHA	30	Hz
7.	MaxFreqHSingle	90	Hz
8.	MaxFreqHMulti	90	Hz
9.	HPAtMinFreqC	42	°C
10.	HPAtMinFreqCA	55	°C
11.	HPAtMinFreqH	42	°C
12.	HPAtMinFreqHA	55	°C
13.	LoadDeadZone	I-T	
14.	DeicerFreq	90	Hz
15.	ODUCodeC	I-T	
16.	ODUCodeH	I-T	
17.	EEVCpctyCrct	I-T	
18.	Step1Freq	40	Hz
19.	Step2Freq	55	Hz
20.	Step3Freq	65	Hz
21.	Step4Freq	75	Hz
22.	Step1Time	3	min
23.	Step2Time	5	min
24.	Step3Time	1	min
25.	Step4Time	1	min
26.	OilLubricationFreq	30	Hz
27.	OFMinRPMC	NA	*10RPM
28.	OFMinRPMH	NA	*10RPM
29.	OFMaxRPM	NA	*10RPM
30.	NightRPM	NA	*10RPM
31.	OFNNoiseMaxRPM	NA	*10RPM
32.	CTTOH0	78	°C
33.	CTTOH1	85	°C
34.	CTTOH2	90	°C
35.	CTTOH3	95	°C
36.	CTTOH4	100	°C
37.	CTTOH5	105	°C
38.	CCROC0	9.0	A
39.	CCROC1	10.5	A
40.	CCROC2	11.5	A
41.	CCROC3	13.0	A
42.	HSTOH0	65	°C
43.	HSTOH1	71	°C
44.	HSTOH2	74	°C
45.	HSTOH3	77	°C
46.	HSTOH4	80	°C
47.	HSTOH5	84	°C
48.	EEVSCProtection	12	°C
49.	EEVMinOperOpenC	50	Step
50.	EEVMaxOperOpenC	480	Step
51.	EEVMinOperOpenH	60	Step
52.	EEVMaxOperOpenH	480	Step
53.	EEVMinOperOpenHInactive	50	Step

#	Name	S YAZ318	Unit
54.	EEVMaxOperOpenHInactive	120	Step
55.	InvAccel	3	NA
56.	InvDecel	1	NA
57.	OCTExitDeicer	12	°C
58.	MaxDeicerTime	15	Minute
62.	EEVDecierOpenSingle	150	Step
63.	EEVDecierOpenMulti	130	Step
59.	DeicerCoef	0.8	NA
60.	EEV_Active_H_Isotherm	6	°C
61.	EEV_Active_H_SC	10	°C
62.	EEV_Active_H_SC_Crct	1	°C
63.	EnableExceedCond	1	
64.	OVRPWR0	2350	Watt
65.	OVRPWR1	2500	Watt
66.	OVRPWR2	2650	Watt
67.	OVRPWR3	2800	Watt
68.	MinSumCapCode	2	NA
69.	MaxSumCapCode	4.5	NA
70.	Max_IDU_Number	4	NA
71.	Default_IDU_Number	3	
72.	InstTestCompSpeed	35	
73.	InstTestEEV	180	Step
74.	OCT_OFAN_Noise_Max	8	°C
75.	OMT_OFAN_Noise_Max	38	°C
76.	OFANType	2	NA
77.	OFMinPercentC	27	NA
78.	OFMinPercentH	27	NA
79.	OFNNoiseMaxPercent	85	NA
80.	NightPercent	50	NA
64.	Target_CTT_Alpha_C	1.467	NA
65.	Target_CTT_Beta_C	0.858	NA
66.	Target_CTT_Gamma_C	0.098	NA
67.	Target_CTT_Delta_C	11.327	NA
68.	Target_CTT_Alpha_H	1.491	NA
69.	Target_CTT_Beta_H	-0.058	NA
70.	Target_CTT_Gamma_H	0.276	NA
71.	Target_CTT_Delta_H	-10.753	NA
81.	ICTDef0	13	°C
82.	ICTDef1	10	°C
83.	ICTDef2	8	°C
84.	ICTDef3	6	°C
85.	ICTDef4	3	°C
86.	ICTDef5	0	°C
87.	ICTOH0	41	
88.	ICTOH1	45	°C
89.	ICTOH2	49	°C
90.	ICTOH3	53	°C
91.	ICTOH4	57	°C
92.	ICTOH5	61	°C
93.	EEV_OL_Alpha1_S_C	12.807	NA
94.	EEV_OL_Beta1_S_C	0.088	NA
95.	EEV_OL_Gamma1_S_C	1.381	NA
96.	EEV_OL_Delta1_S_C	-177	NA

CONTROL SYSTEM



#	Name	S YAZ318	Unit
97.	EEV_OL_Alpha2_S_C	1.989	
98.	EEV_OL_Beta2_S_C	-3.099	
99.	EEV_OL_Gamma2_S_C	1.054	
100.	EEV_OL_Delta2_S_C	204	NA
101.	EEV_OL_Alpha3_S_C	1.989	
102.	EEV_OL_Beta3_S_C	-3.099	
103.	EEV_OL_Gamma3_S_C	1.054	
104.	EEV_OL_Delta3_S_C	204	NA
105.	EEV_OL_Alpha1_S_H	3.003	NA
106.	EEV_OL_Beta1_S_H	3.789	NA
107.	EEV_OL_Gamma1_S_H	1.401	NA
108.	EEV_OL_Delta1_S_H	-22	NA
109.	EEV_OL_Alpha2_S_H	3.003	NA
110.	EEV_OL_Beta2_S_H	3.789	NA
111.	EEV_OL_Gamma2_S_H	1.401	NA
112.	EEV_OL_Delta2_S_H	-22	NA
113.	EEV_OL_Alpha3_S_H	-3.538	NA
114.	EEV_OL_Beta3_S_H	3.099	NA
115.	EEV_OL_Gamma3_S_H	1.393	NA
116.	EEV_OL_Delta3_S_H	108	NA
117.	EEV_OL_OAT1_S_C	25	NA
118.	EEV_OL_OAT2_S_C	35	NA
119.	EEV_OL_OAT1_S_H	-3	NA
120.	EEV_OL_OAT2_S_H	9	NA
121.	EEV_OL_Alpha_M1_C	12.026	NA
122.	EEV_OL_Beta_M1_C	0.576	NA
123.	EEV_OL_Gamma_M1_C	1.16	NA
124.	EEV_OL_Delta_M1_C	-179	NA
125.	EEV_OL_Alpha_M2_C	5.34	NA

#	Name	S YAZ318	Unit
126.	EEV_OL_Beta_M2_C	-0.797	NA
127.	EEV_OL_Gamma_M2_C	1.782	NA
128.	EEV_OL_Delta_M2_C	-71	NA
129.	EEV_OL_Alpha_M3_C	3.149	NA
130.	EEV_OL_Beta_M3_C	-0.115	NA
131.	EEV_OL_Gamma_M3_C	1.54	NA
132.	EEV_OL_Delta_M3_C	-61	NA
133.	EEV_OL_Alpha_M4_C	NA	NA
134.	EEV_OL_Beta_M4_C	NA	NA
135.	EEV_OL_Gamma_M4_C	NA	NA
136.	EEV_OL_Delta_M4_C	NA	NA
137.	EEV_OL_Alpha_M1_H	0	NA
138.	EEV_OL_Beta_M1_H	3.95	NA
139.	EEV_OL_Gamma_M1_H	2.196	NA
140.	EEV_OL_Delta_M1_H	-18	NA
141.	EEV_OL_Alpha_M2_H	0	NA
142.	EEV_OL_Beta_M2_H	2.717	NA
143.	EEV_OL_Gamma_M2_H	0.962	NA
144.	EEV_OL_Delta_M2_H	16	NA
145.	EEV_OL_Alpha_M3_H	0	NA
146.	EEV_OL_Beta_M3_H	2.337	NA
147.	EEV_OL_Gamma_M3_H	0.958	NA
148.	EEV_OL_Delta_M3_H	1	NA
149.	EEV_OL_Alpha_M4_H	NA	NA
150.	EEV_OL_Beta_M4_H	NA	NA
151.	EEV_OL_Gamma_M4_H	NA	NA
152.	EEV_OL_Delta_M4_H	NA	NA

11.10.3 Indoor Units SW Parameters

11.10.3.1 General Parameters for All Models:

Parameters defining the indoor fan speed as a function of Indoor Coil temperature in heat mode (ICT):

ICTST Speed	ICT to stop indoor fan	25
ICTVLSpeed	ICT to go down to very low speed	28
ICTLSpeed	ICT to start in very low speed	30
ICTHSpeed	ICT to start in increase speed from very low	32
ICTTSpeed	ICT to enable Turbo fan speed	40

Parameters for IDU defrost protection:

ICTDef1	ICT to go back to normal	8
ICTDef2	ICT to 'stop rise' when ICT decrease	6
ICTDef3	ICT to 'stop rise' when ICT is stable	4
ICTDef4	ICT to 'Hz Down' when ICT decrease	2
ICTDef5	ICT to 'Hz Down' when ICT is stable	0
ICTDef6	ICT to stop compressor	-2

Parameters for indoor coil over heating protection:

ICTOH1	ICT to go back to normal	45
ICTOH2	ICT to 'stop rise' when ICT increase	48
ICTOH3	ICT to 'stop rise' when ICT is stable	52
ICTOH4	ICT to 'Hz Down' when ICT increase	55
ICTOH5	ICT to 'Hz Down' when ICT is stable	60
ICTOH6	ICT to stop compressor	62

12. TROUBLESHOOTING

WARNING!!!

When Power Up – the whole outdoor unit controller, including the wiring, is under HIGH VOLTAGE!!!

Never open the Outdoor unit before turning off the Power!!!

When turned off, the system is still charged (400V)!!!

It takes about 1 Min. to discharge the system.

Touching the controller before discharging may cause an electrical shock!!!

For safe handling of the controller, please refer to section 12.5 below.

12.1 General System Failures and Corrective Actions

No	SYMPTOM	PROBABLE CAUSE	CORRECTIVE ACTION
1.	Indoor unit power supply indicator (Red LED) does not light up.	No power supply	Check power supply. If OK, check display and display wiring. if OK, replace controller
2.	Indoor unit does not respond to remote control message	Remote control message not reached the indoor unit	Check remote control batteries, if OK, check display and display wiring, if OK, replace display PCB. If still not OK replace controller
3.	Indoor unit responds to remote control message but Operate indicator (Green LED) does not light up	Problem with display PCB	Replace display PCB. If still not OK replace controller
4.	Indoor fan does not start (louvers are opened and Green LED is ON)	Unit in heat mode and coil is still not warm	Change to cool mode
		Outdoor unit is in opposite mode	Change operation mode
		Problem with controller or capacitor	Change to high speed and Check power supply to motor is higher than 130VAC (for triack controlled motor) or higher than 220VAC for fixed speed motors, if OK replace capacitor, if not OK replace controller
5.	Indoor fan works when unit is OFF, and indoor fan speed is not changed by remote control command.	Controller problem	Replace controller
6.	Water leakage from indoor unit	Indoor unit drainage tube is blocked	Check and open drainage tube
7.	One indoor unit or more are operating in cool mode with no capacity, and the other units have water leaks/freezing problems	The communication wires of the indoor units are switched	Check and correct the communication wires connection
8.	One indoor or more are operating in heat mode with a limited capacity, and the coil on the other units are very hot.		
9.	Outdoor unit display board and leds are off	No power supply	Check the connections and the wiring on the main terminal - Repair if needed. Check PFC choke connection.

No	SYMPTOM	PROBABLE CAUSE	CORRECTIVE ACTION
			- Repair if needed
		PFC Chock coil	Check the PFC Chock coil
		Burnt fuse	Check 20A fuse on the Filter (12.4.2)
10.	Compressor operates but one or more units generates no capacity	EEV problem	Check EEV (12.4.5)
		Refrigerant leakage	Check refrigeration system (12.2)
		Indoor coil block	Clean filters and/or remove block
		Outdoor coil block	Remove block and/or avoid air by-pass
11.	Compressor is over heated and unit does not generate capacity	EEV problem	Check EEV (12.4.5)
		Refrigerant leakage	Check refrigeration system (12.2)
		Indoor coil block	Clean filters and/or remove block
		Outdoor coil block	Remove block and/or avoid air by-pass
12.	Compressor stops during operation	Electronic control	Check diagnostics (see 12.3 below)
		Refrigerant leakage	Check refrigeration system (12.2)
13.	Not all units are operating	Communication problems	Check diagnostics (see 12.3 below)
14.	Compressor does not start	Electronics control problem or protection	
15.	Unit works in wrong mode (cool instead of heat or heat instead of cool)	Electronics or RV problem	Check RV (12.4.4)
16.	All components are operating properly but no cooling or no heating	Refrigerant leak	Check refrigeration system (12.2)
17.	Compressor motor is generating noise and no suction occurs	Phase order to compressor is wrong	Check compressor phase order
18.	Freezing of outdoor unit in heat mode and outdoor unit base is blocked with ice		Connect base heater
19.	The unit stop suddenly during operation	EMC interference to the A/C unit	Check for EMC problems (12.4.8.1)
20.	Indoor unit(s) Indicator(s) leds may flicker		
21.	Other home appliances operation is faulty such as noise appears in the television picture, or the picture is distorted or static occurs in the radio sound	EMC interference by the A/C unit	Check for EMC problems (12.4.8.2)
22.	All others	Specific problems of indoor or outdoor units	Check diagnostics (see 12.3 below)

12.2 Checking the refrigeration system

Checking system pressures and other thermodynamic measures should be done when system is in technician Mode where the system operates as in fixed settings. The performance curves given in this manual are given for unit performance in Technician mode when high indoor fan speed is selected. For entering technician mode, refer to 11.7.

12.3 Diagnostics

12.3.1 Fault Code for Outdoor unit

The last fault occurred in the system will be stored in the EEPROM.

If no fault exists in the system, no fault code will be displayed during normal operation mode.

For single Split units only, when system enters diagnostics mode (through IDU communication), the last fault code will be displayed even if the system has recover from that fault. The last fault will be deleted from the EEPROM after the system has exit diagnostics mode (through IDU communication). The current system operation mode (cool/ heat/ off) will not be changed when system enters diagnostics.

The coding method is as follow:

STATUS LED is blinking 5 times in 5 seconds, and shut off for the next 5 seconds.

FAULT LED will blink during the same 5 seconds according to the following table

No	Problem	AO	5	4	3	2	1
1	OCT is shorted/disconnected	Yes	0	0	0	0	1
2	CTT is shorted/disconnected	Yes	0	0	0	1	0
3	HST is shorted/disconnected	Yes	0	0	0	1	1
4	OAT is shorted/disconnected	Yes	0	0	1	0	0
5	OMT is shorted/disconnected	Yes	0	0	1	0	1
6	RGT is shorted/disconnected	Yes	0	0	1	1	0
7	RLT is shorted/disconnected	Yes	0	0	1	1	1
8	Reserved	No	0	1	0	0	0
9	Reserved	No	0	1	0	0	1
10	Reserved	No	0	1	0	1	0
11	Compressor IPM Fault / IPM Driver Pin / Compressor Current Sensor Fault	Yes	0	1	0	1	1
12	Bad EEPROM	No	0	1	1	0	0
13	DC under voltage	Yes	0	1	1	0	1
14	DC over voltage	Yes	0	1	1	1	0
15	AC under voltage/AC over Voltage/Zero Crossing detection	Yes	0	1	1	1	1
16	Mismatch between IDU & ODU models	Yes	1	0	0	0	0
17	No Communication	Yes	1	0	0	0	1
18	System Over Power	Yes	1	0	0	1	0
19	PFC Current sensor	Yes	1	0	0	1	1
20	Heat sink Over Heating	No	1	0	1	0	0
21	Deicing	No	1	0	1	0	1
22	Compressor Over Heating	No	1	0	1	1	0
23	Compressor Over Current	No	1	0	1	1	1
24	No OFAN Feedback	Yes	1	1	0	0	0
25	OFAN IPM fault / OFAN IPM Driver Pin	Yes	1	1	0	0	1
26	Compressor Lock	Yes	1	1	0	1	0
27	Bad Communication	No	1	1	0	1	1
28	Missing ODU configuration	Yes	1	1	1	0	0
29	Undefined ODU Model	Yes	1	1	1	0	1
30	Outdoor/Indoor Coil Overheating	No	1	1	1	1	0
31	Operation conditions are exceeded	Yes	1	1	1	1	1

One – ON, 0 – OFF

Only one code is shown. Order of priority is 1-24. Diagnostics is continuously ON as long power is on.

12.3.2 Outdoor unit diagnostics and corrective actions

No	Fault Name	Fault Description	Corrective Action
1	OCT bad	Thermistor not connected or damaged	Check Thermistor (12.4.6)
2	CTT bad		
3	HST bad		
4	OAT bad		
5	OMT bad		
6	RGT bad		
7	RLT bad		
8	Reserved	NA	NA
9	Reserved	NA	NA
10	Reserved	NA	NA
11	Compressor IPM Fault / IPM Driver Pin / Compressor Current Sensor Fault	PM module detect shoot-through current / IPM driver control pin is unconditionally latch to high state / The quiescent reference voltage of sensor resistor is either too high or too low.	Disconnect the compressor plug and measure between U-V, U-W for resistance using multimeter. Resistance value should be below 1 OHM. If multimeter display high resistance, replace compressor. Make sure the phase sequence of U-V-W is correctly plug into the compressor, otherwise replace controller if error is persistent
12	Bad EEPROM	Writing to EEPROM is impossible or EEPROM IC is damage	There is no electronic corrective action, just replace controller if error is persistent. Note: A/C still be able to operate, but no event logging and mode restore on power up
13	DC under voltage	The capacitor bank DC voltage supply for the compressor is below operable value	Check AC input line voltage RMS value, it should read above 198VAC. If voltage is above 198VAC, and DC under voltage error is continuous display, replace controller.
14	DC over voltage	The capacitor bank DC voltage supply for the compressor is too high value	Check AC input line voltage RMS value, it should read below 264VAC. If voltage is below 264VAC, and DC over voltage error is continuously display, replace controller.
15	AC under voltage/AC over Voltage/Zero Crossing detection	The AC input supply voltage is below the limit of 198V / The AC input supply voltage is above 264V / The AC line frequency is out of range from 45Hz to 55Hz.	Check AC input line voltage RMS value, it should read in the range of 198VAC – 264VAC. Check AC input line operating frequency, it should be in the range from 45Hz to 55Hz. If error is continuously being display, replace controller.
16	Mismatch between IDU & ODU models	Miss-match between the IDUs connected to port A,B,C or D, or the total capacity code of IDUs is higher than the ODU maximum capacity code	Change configuration if needed.
17	No Communication	No signals in lineA,B,C,D	Check communication (12.4.7)
18	System Over Power	Compressor stopped due to over power protection	No action required
19	PFC Current sensor	Controller cannot detect valid AC line current after compressor start	If error is continuously being display, replace controller.

TROUBLESHOOTING

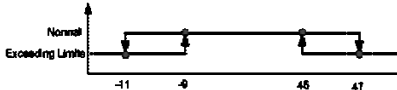
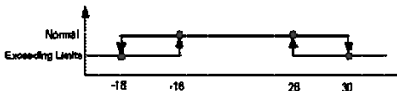
No	Fault Name	Fault Description	Corrective Action
20	Heat sink Over Heating	Compressor stopped due to heatsink protection	Check that the airflow around the ODU is free and the fan is running free. Check fan motor
21	Deicing	During deicing procedure	No action required
22	Compressor Over Heating	Compressor stopped due to over heat protection	Check if gas is missing in the system
23	Compressor Over Current	Compressor stopped due to over current protection	No action required
24	No OFAN Feedback	No encoder signal can be detected from the OFAN	Check DC-FAN hall sensor connection/plug for damage. Check DC-FAN for any blockage. Measure between U-V, U-W for resistance using multimeter. Resistance value should be below 1 OHM. If multimeter display high resistance, replace DC-FAN motor, otherwise replace controller.
25	OFAN IPM fault / OFAN IPM Driver Pin	OFAN IPM module detect shoot-through current / OFAN IPM driver control pin is unconditionally latch to high state	Check DC-FAN hall sensor connection/plug for damage. Check DC-FAN for any blockage. Measure between U-V, U-W for resistance using multimeter. Resistance value should be below 1 OHM. If multimeter display high resistance, replace DC-FAN motor. Return controller if error is persistent.
26	Compressor Lock	No correct drive current can be detected from the compressor	Check compressor cable or compressor wire assembly. Make sure the phase sequence of U-V-W is correctly plug into the compressor.
27	Bad Communication	Lost of communication from indoor unit	Check communication wire between indoor and outdoor unit
28	Missing ODU configuration	All the DIP is set to 0 (the DIP are not configured).	This problem cannot happen in DCI80. Previously, this fault is used to detect model plug that fall down.
29	Undefined ODU Model	The outdoor model is not defined in the software.	Wrong Outdoor DIP setting. Too old outdoor software. Update software
30	Outdoor/Indoor Coil Overheating	This protection combines the following: Overheating in cooling mode (based on OMT reading). Overheating in heating mode based on ICT.	Improper ventilation of the coils Over charged system Problem with ICT sensors or OMT sensor (fake up). Illegal too small indoor unit's installation (heating).
31	Operation conditions are exceeded	For cooling:  For Heating: 	This is not a fault but information on the ambient operation: The unit operates outside the defined operation range. The OAT fakes and cause false alarm.

12.3.3 DMSMP diagnostics

The DMSMP system has 4 IDU LEDs, 1 ODU LED, and 1 Power LED. Each communication channel is built up from receiving and transmitting channels. The outdoor controller is the master of communication (always initiated communication) while the DMSMP and indoor are slave (responds only when it receives).

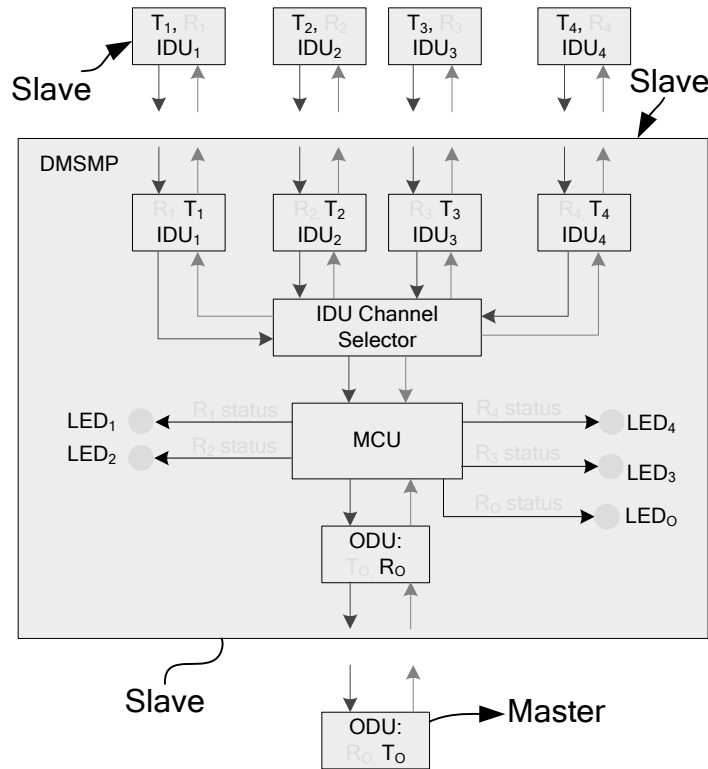

Channel	LED
R _i has communication	The relevant LED _i will be ON.
R _i has no communication	The relevant LED _i will be Off.

Damage	ODU	IDU	LED on DMSMP					How to check?
			1	2	3	4	O	
T ₀ (ODU)	No Com	All no com	Off	Off	Off	Off	Off	Voltage To(ODU) no change
R ₀ (DMSMP)	No Com	All no com	Off	Off	Off	Off	Off	Voltage To(ODU) changes Voltage Ro(DMSMP) no change
T ₀ (DMSMP)	No com	All ok	On	On	On	On	On	Voltage Ro(DMSMP) changes Voltage To(DMSMP) no change
R ₀ (ODU)	No com	All ok	On	On	On	On	On	Voltage To (DMSMP) changes. Voltage To (ODU) no changes.
T ₄ (DMSMP)	Ok	Indoor 4	On	On	On	Off	On	Exchange with other IDU to know the problem is in the IDU or the DMSMP.
R ₄ (IDU)	Ok	Indoor 4	On	On	On	Off	On	
T4(IDU)	Ok	All ok	On	On	On	Off	On	
R4(DMSMP)	Ok	All ok	On	On	On	Off	On	

12.3.4 Fault Code for Indoor unit

Pressing Mode button for long will activate diagnostic mode by the acknowledgment of 3 short beeps and lighting of COOL and HEAT LED's.

When Indoor diagnostics is displayed, all four LED's (STBY, Operate, Filter, TMR) are on.

Entering diagnostics in STBY mode allows only viewing of status (fault-display).

In diagnostic mode, system problems / information will be indicated by blinking of Heat & Cool LED's.

The coding method will be as follows:

Heat led will blink 5 times in 5 seconds, and then will be shut off for the next 5 seconds. Cool Led will blink during the same 5 seconds according to the following table:

No	Fault Name	5	4	3	2	1
1	RT-1 is disconnected	~	~	~	~	1
2	RT-1 is shorted	~	~	~	1	~
3	RT-2 is disconnected	~	~	~	1	1
4	RT-2 is shorted	~	~	1	~	~
...	Reserved	~	~	1	~	1
7	Communication mismatch	~	~	1	1	1
8	No Communication	~	1	~	~	~
9	No Encoder	~	1	~	~	1
10	Reserved	0	1	0	1	0
11	Outdoor Unit Fault	0	1	0	1	1
...	Reserved					
17	Defrost protection	1	~	~	~	1
18	Deicing Protection	1	~	~	1	~
19	Outdoor Unit Protection	1	~	~	1	1
20	Indoor Coil HP Protection	1	~	1	~	~
21	Overflow Protection	1	~	1	~	1
...	Reserved					
24	EEPROM Not Updated	1	1	~	~	~
25	Bad EEPROM	1	1	~	~	1
26	Bad Communication	1	1	~	1	~
27	Using EEPROM data	1	1	~	1	1
28	Model A	1	1	1	~	~
29	Model B	1	1	1	~	1
30	Model C	1	1	1	1	~
31	Model D	1	1	1	1	1

1 - ON, 0 - OFF

Only one code is shown. Order of priority is lower to the higher number. Diagnostics is continuously ON as long power is on.

12.3.5 Indoor unit diagnostics and corrective actions

No.	Fault	Probable Cause	Corrective Action
1-4	Sensor failures	Sensors not connected or damaged	Check sensor connections or replace sensor
7	Communication mismatch	Indoor and Outdoor controllers are with different versions	Replace Indoor controller
8	No Communication	Communication or grounding wiring is not good	Check Indoor to Outdoor wiring and grounding
9	No Encoder	Indoor electronics or motor	Check motor wiring, if ok, replace motor, if still not ok, replace Indoor controller.
11	Outdoor Unit Fault	Outdoor controller problem	Switch to Outdoor diagnostics.
17-21	Protections	Indication	No action
24	EEPROM Not Updated	System is using ROM parameters and not EEPROM parameters	No action, unless special parameters are required for unit operation.
25	Bad EEPROM		No action, unless special parameters are required for unit operation.
26	Bad Communication	Communication quality is low reliability	Check Indoor to Outdoor wiring and grounding
27	Using EEPROM data	No problem	
28-31	IDU model	Indication : DCI-25,35,50,60	

12.4 Procedures for checking Main Parts**12.4.1 Checking Mains Voltage**

Confirm that the Mains voltage is between 198 and 264 VAC. If Mains voltage is out of this range, abnormal operation of the system is expected. If in range check the Power (Circuit) Breaker and look for broken or loosed cable lugs or wiring mistake(s).

12.4.2 Checking Main fuse

Check 20A fuse on the Filter Board - If burnt – check the compressor, fan or any other peripheral that can cause a short. In case of a problematic peripheral - replace it.
In case no problematic peripheral, check the resistance on the DC bank (B+ & B- on the Power board), if it is less than 30Ω, replace the controller. Otherwise replace the burnt fuse.
In case of frequent burning fuse, replace the controller.

12.4.3 Checking the Compressor

Check Compressor connections - Repair if needed.
Use a current probe (“Clamp”) to assure that there is an AC current on each phase – no more than 15A.
In case there is no current, check the resistance between the three poles. Assure the three coil resistances are almost the same (between 0.8Ω to 1.5Ω).
Change to Stand-by or Power OFF and re-start - If the fault is still “Active” - replace controller.

12.4.4 Checking the Reverse Valve (RV)

The RV has two parts, Solenoid and valve.
Solenoid - Running in heating mode, check the voltage between two pins of reverse valve connector, normal voltage is 230VAC. if no power supply to RV, Check RV operation with direct 230VAC power supply, if OK, replace outdoor controller.
Valve - if RV solenoid is OK (as above) but still no heating operation while compressor is On, replace the valve.

12.4.5 Checking the electrical expansion valve (EEV)

The EEV has two parts, drive and valve.

When Outdoor unit is powered on, EEV shall run and have click and vibration.

For assuring the problem is of the EEV parts, perform the installation test. check (11.6) and if fails and no other indications in the diagnostics, than the problem is with the EEV (one or more).

Drive - a step motor; ringed on the valve. Check the drive voltage, should be 12VDC.

Valve – if drive is OK (as above) but still the indoor unit perform no conditioning replace the valve (no need to take out the refrigerant, just pump down and shut off the main valves).

12.4.6 Checking the thermistors

Check Thermistor connections and wiring - Repair if needed.

Check Thermistor resistance – between 0°C and 40°C should be between 35KΩ and 5KΩ.

12.4.7 Checking the communication

Change to Stand-by or Power OFF and re-start - If the fault is still “Active” check Indoor to Outdoor Communication wiring and grounding connections (should be less than 2.0Ω) - Repair if needed.

If IDU failure – replace IDU controller that does not respond.

If ODU failure – replace ODU.

12.4.8 Checking for electromagnetic interference (EMC problems)

12.4.8.1 EMC troubles to the A/C unit

Locations most susceptible to noise :

1. Locations near broadcast stations where there are strong electromagnetic waves.
2. Locations near amateur radio (short wave) stations.
3. Locations near electronic sewing machines and arc-welding machines.

Trouble :

Either of the following trouble may occur:

1. The unit may stop suddenly during operation.
2. Indicator lamps may flicker

Correction :

The fundamental concept is to make the system less susceptible to noise (insulate for noise or distance from the noise source):

1. Use shielded wires.
2. Move unit away from the noise source.

12.4.8.2 EMC troubles to near by home appliances

Locations most susceptible to noise :

1. A television or radio is located near the A/C and A/C wiring.
2. The antenna cable for a television or radio is located close to the A/C and A/C wiring.
3. Locations where television and radio signals are weak.

Trouble :

1. Noise appears in the television picture, or the picture is distorted.
2. Static occurs in the radio sound.

Correction

1. Select a separate power source.
2. Keep the A/C and A/C wiring at least 1 meter away from wireless devices and antenna cables.
3. Change the wireless device's antenna to a high sensitivity antenna.
4. Change the antenna cable to a BS coaxial cable.
5. Use a noise filter (for the wireless device).
6. Use a signal booster.

12.5 Precaution, Advise and Notice Items

12.5.1 High voltage in Outdoor unit controller

Whole controller, including the wires, connected to the Outdoor unit controller may have the potential hazard voltage when power is on. Touching the Outdoor unit controller may cause an electrical shock.

Advise: Don't touch the naked lead wire and don't insert finger, conductor or anything else into the controller when power is on.

12.5.2 Charged Capacitors

Three large-capacity electrolytic capacitors are used in the Outdoor unit controller. Therefore, charging voltage (380VDC) remains after power down. Discharging takes about one minute after turned off. Touching the Outdoor unit controller before discharging may cause an electrical shock. When open the Outdoor unit controller cover, do not touch the soldering pin by hand or by any conductive material.

Advise:

- Open the Outdoor unit controller cover only after one minute from power off.
- Measure the electrolytic capacitors voltage before farther checking controller.

Additional advises

- When disassemble the controller or the front panel, turn off the power supply.
- When connecting or disconnecting the connectors on the PCB, hold the whole housing, do not pull the wire.
- There are sharp fringes and sting on shell. Use gloves when disassemble the A/C units.

13. EXPLODED VIEW AND SPARE PART LIST

13.1 Multi YAZ318 – Exploded View

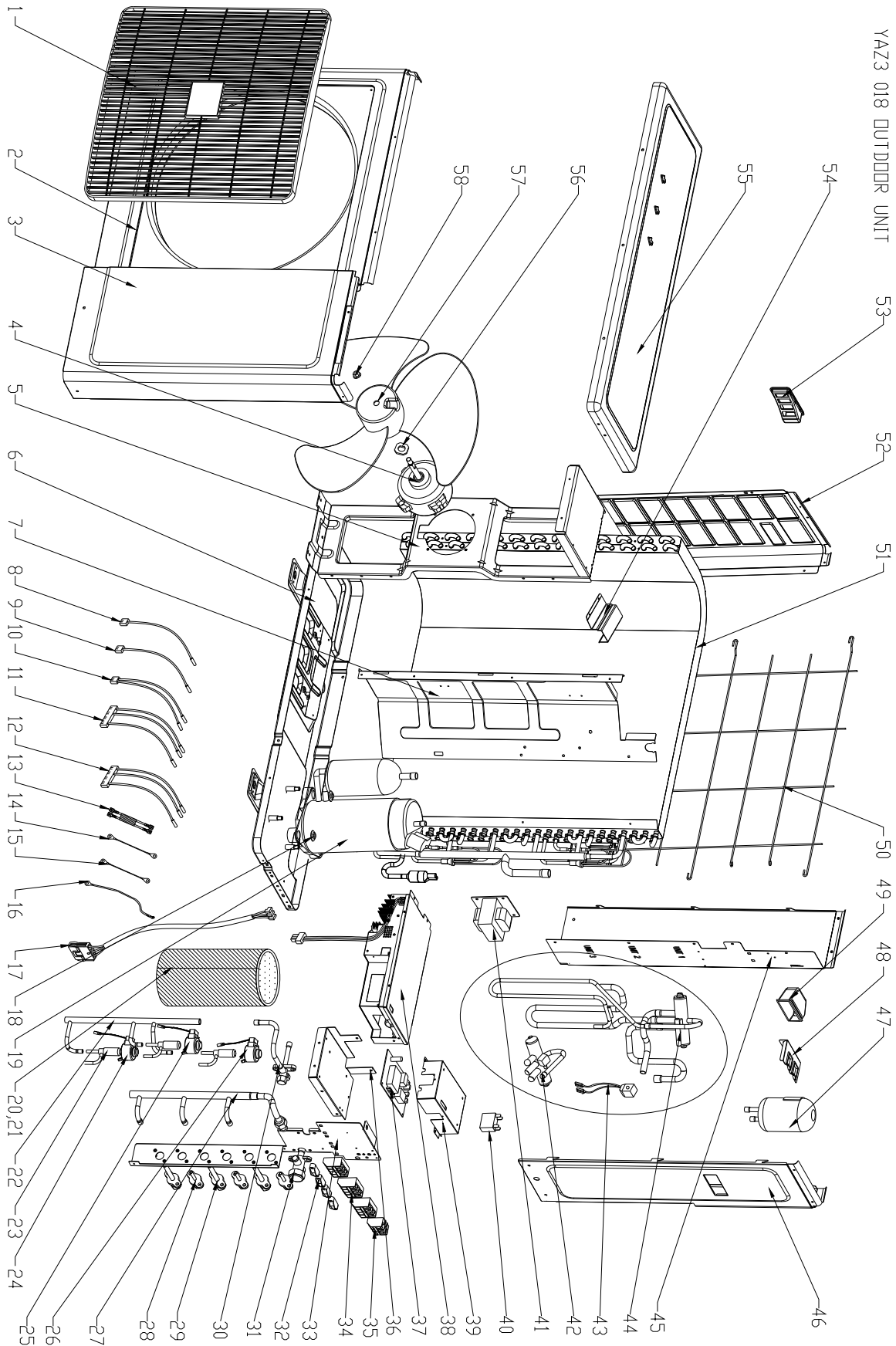

13.2 Multi YAZ318 DCI – Spare Part List

Item Seq	Item	Description	Quantity
1	4517144	FAN COVER PP+UV/GRILL A	1
2	452795700	PAINTED LEFT CABINET ASSY	1
3	464660009	Front Plate Painting Assy./DCI TRIO DELTA	1
4	466100048R	Metal Motor /YBD022	1
5	C60095900	Motor Support/MTS 4kW	1
6	464600119	Base Plate Painting Assy./YAZ3 018	1
7	464160004	Partition Plate	1
8	467400056	OCT Outdoor Coil Temperature Sensor/10K/Copper-capsulation \varnothing 6	1
9	467400200	CTT Compressor Top Temperature Sensor/10K/Resin-capsulation	1
10	467400040	Condenser Middle Temperature Sensor/OAT & OMT/DCR LC 25/35	1
11	467400041	Return Liquid Temperature Sensor(RLT) /Trio 72 DCI	1
12	467400068	RGT Return Gas Temperature Sensor/10K/Copper-capsulation \varnothing 6	1
13	4526226	Power lead wire	3
14	455015204	ground wire,UL1015 16AWG(1.5),250mm	3
15	4516540	GROUND WIRE	1
16	4513592	Ground wire	1
17	4526221	Compressor wire	1
18	4510677	Nut With Flange M8 -D=24 GB6187-86	3
19	460170013R	Compressor Assy./ GMCC DA150S1C-20FZ	1
20	469120017	Insulation Felt+PVC/Compressor GMCC DA150/YBD022	1
21	469120019	Insulation Felt+PVC/Outside	1
22	463700004	Distributing Pipe Assy./DCI TRIO DELTA	1
23	4526827	Electronical expansion valve CAM-BD15 FKS-1	3
24	452682803	EEV coil(Green connector, 800mm)	1
25	452682800	EEV coil CAM-MD12FKS-1 (Red, 530mm)	1
26	452682802	EEV coil CAM-MD12FKS-2 (White connector, 530mm)	1
27	463650003	Manifold Assy./DCI TRIO DELTA	1
28	452783501	Brass Connector with Flange 3/8"	3
29	452783502	Brass Connector with Flange 1/4"	3
30	452783100	High Pressure Stop Valve 3/8" R410a	1
31	461010018	Gas Valve 1/2" R410A	1
32	204107	Cable clip Nylon	4
33	464860026	Valve Support Painting Assy.	1
34	467420025	4 Poles Terminal Block	3
35	467420030	3 Poles Terminal Block/TRIO52 QUATTRO80	1
36	464200062	DMSMP Support/YAZ3 018	1
37	467300232R	Communication Board /DMSMP	1
38	467300233R	Controller/ DCRS 2.8KW Sine Wave Main BD	1
39	464250161	Communication Board Box Cover /DMSMP/DCI DUO 50 Z R410A	1
40	455000104	Double patch Capacitor for fan motor 4uF (CBB61S)	1
41	467550005R	Choke/ DCR 50 Z	1
42	461020004	4-W valve /SHF(L)-7H-34U	1
43	461030007	4-W valve coil /SHF(L)-4H/7H(DCI)	1
44	461600113	4-Way Valve Assy./YAZ3 018	1
45	464770006	Rear Plate Painting Assy./DCI TRIO DELTA	1
46	464630008	Side Plate Painting Assy./DCI TRIO DELTA	1
47	463250001	Liquid Accumulator	1
48	464860027	Drain Plate Painting Assy.	1
49	4517772	Little Handle	1
50	464800019	Guard Net/ODU Painting Assy/GC 18	1
51	462300126	Condenser Welding Assy./YBD 022	1
52	464080009	Rear Plate/ Left Painting Assy/GC 18	1
53	4516758	SMALL HANDLE	1
54	4526585	Connect for motor backed	1
55	4516788	PAINTED TOP COVER ASSY	1
56	4526841	cushion for fan	1
57	4526510	FAN D=460mm (3 blade)	1
58	4523141	M10 Hexagon locked nut M10	1

14. APPENDIX A

INSTALLATION AND OPERATION MANUAL