

– DC INVERTER Air Conditioner – for Refrigerant R410A

■ R410A Models Indoor Units

	Indoor Unit Type	12	16	18	25	36	48	60
4WK	4-Way Air Discharge Semi-Concealed	IU-PSINV-4WK12R	IU-PSINV-4WK16R	IU-PSINV-4WK18R	IU-PSINV-4WK25R	IU-PSINV-4WK36R	IU-PSINV-4WK48R	IU-PSINV-4WK60R
HW	Wall-Mounted	IU-PSINV-HW12R	IU-PSINV-HW16R	IU-PSINV-HW18R	IU-PSINV-HW25R			
C	Ceiling-Mounted	IU-PSINV-C12R	IU-PSINV-C16R	IU-PSINV-C18R	IU-PSINV-C25R	IU-PSINV-C36R	IU-PSINV-C48R	IU-PSINV-C60R
D	Concealed-Duct	IU-PSINV-D12R	IU-PSINV-D16R	IU-PSINV-D18R	IU-PSINV-D25R	IU-PSINV-D36R	IU-PSINV-D48R	IU-PSINV-D60R

Outdoor Units

OU	Outdoor Units	OU-PSINV-25HR, OU-PSINV-36HR, OU-PSINV-48HR, OU-PSINV-60H
----	---------------	---

* Refrigerant R410A is used in the outdoor units.

Optional Controllers

RC	Remote Controller	NRCT-FLR
	Wireless Remote Controller (For 4WK type)	AWAC-RCIRA-FL
	Wireless Remote Controller (For C type)	AWAC-RCIRD-FL
	Wireless Remote Controller (For D type)	AWAC-RCIRC-FL
	Wireless Remote Controller (For HW type)	AWAC-RCIRE-FL
	Simplified Remote Controller	NRCB-FLR
	Remote Sensor	NSDR
	System Controller	NRSC-FLR
	Schedule Timer	NWTM-FLR

IMPORTANT!

Please Read Before Starting

This air conditioning system meets strict safety and operating standards. As the installer or service person, it is an important part of your job to install or service the system so it operates safely and efficiently.

For safe installation and trouble-free operation, you must:

- Carefully read this instruction booklet before beginning.
- Follow each installation or repair step exactly as shown.
- Observe all local, state, and national electrical codes.

Note: This air conditioner uses the new refrigerant R410A. This product is intended for professional use. Permission from the power supplier is required when installing an outdoor unit that is connected to a 16 A distribution network.

- Pay close attention to all warning and caution notices given in this manual.

 **WARNING** This symbol refers to a hazard or unsafe practice which can result in severe personal injury or death.

 **CAUTION** This symbol refers to a hazard or unsafe practice which can result in personal injury or product or property damage.

If Necessary, Get Help

These instructions are all you need for most installation sites and maintenance conditions. If you require help for a special problem, contact our sales/service outlet or your certified dealer for additional instructions.

In Case of Improper Installation

The manufacturer shall in no way be responsible for improper installation or maintenance service, including failure to follow the instructions in this document.

SPECIAL PRECAUTIONS

WARNING When Wiring



ELECTRICAL SHOCK CAN CAUSE SEVERE PERSONAL INJURY OR DEATH. ONLY A QUALIFIED, EXPERIENCED ELECTRICIAN SHOULD ATTEMPT TO WIRE THIS SYSTEM.

- Do not supply power to the unit until all wiring and tubing are completed or reconnected and checked.
- Highly dangerous electrical voltages are used in this system. Carefully refer to the wiring diagram and these instructions when wiring. Improper connections and inadequate grounding can cause **accidental injury or death**.
- **Ground the unit** following local electrical codes.
- Connect all wiring tightly. Loose wiring may cause overheating at connection points and a possible fire hazard.

When Transporting

Be careful when picking up and moving the indoor and outdoor units. Get a partner to help, and bend your knees when lifting to reduce strain on your back. Sharp edges or thin aluminum fins on the air conditioner can cut your fingers.

When Installing...

...In a Room

Properly insulate any tubing run inside a room to prevent "sweating" that can cause dripping and water damage to walls and floors.

...In Moist or Uneven Locations

Use a raised concrete pad or concrete blocks to provide a solid, level foundation for the outdoor unit. This prevents water damage and abnormal vibration.

...In an Area with High Winds

Securely anchor the outdoor unit down with bolts and a metal frame. Provide a suitable air baffle.

...In a Snowy Area (for Heat Pump-type Systems)

Install the outdoor unit on a raised platform that is higher than drifting snow. Provide snow vents.

When Connecting Refrigerant Tubing

- Ventilate the room well, in the event that refrigerant gas leaks during the installation. Be careful not to allow contact of the refrigerant gas with flame as this will cause the generation of poisonous gas.
- Keep all tubing runs as short as possible.
- Use the flare method for connecting tubing.
- Apply refrigerant lubricant to the matching surfaces of the flare and union tubes before connecting them, and then tighten the nut with a torque wrench for a leak-free connection.
- Check carefully for leaks before starting the test run.

When Servicing

- Turn the power OFF at the main power box (mains) before opening the unit to check or repair electrical parts and wiring.
- Keep your fingers and clothing away from any moving parts.
- Clean up the site after you finish, remembering to check that no metal scraps or bits of wiring have been left inside the unit being serviced.



CAUTION

- Ventilate any enclosed areas when installing or testing the refrigeration system. Escaped refrigerant gas, on contact with fire or heat, can produce dangerously toxic gas.
- Confirm after installation that no refrigerant gas is leaking. If the gas comes in contact with a burning stove, gas water heater, electric room heater or other heat source, it can cause the generation of poisonous gas.

Check of Density Limit

The room in which the air conditioner is to be installed requires a design that in the event of refrigerant gas leaking out, its density will not exceed a set limit.

The refrigerant (R410A), which is used in the air conditioner, is safe, without the toxicity or combustibility of ammonia, and is not restricted by laws imposed to protect the ozone layer. However, since it contains more than air, it poses the risk of suffocation if its density should rise excessively. Suffocation from leakage of refrigerant is almost non-existent. With the recent increase in the number of high density buildings, however, the installation of multi air conditioner systems is on the increase because of the need for effective use of floor space, individual control, and energy conservation by curtailing heat and carrying power, etc.

Most importantly, the multi air conditioner system is able to replenish a large amount of refrigerant compared to conventional individual air conditioners. If a single unit of the multi air conditioner system is to be installed in a small room, select a suitable model and installation procedure so that if the refrigerant accidentally leaks out, its density does not reach the limit (and in the event of an emergency, measures can be made before injury can occur).

In a room where the density may exceed the limit, create an opening with adjacent rooms, or install mechanical ventilation combined with a gas leak detection device. The density is as given below.

Total amount of refrigerant (kg)

$$\text{Min. volume of the indoor unit installed room (m}^3\text{)} \leq \text{Density limit (kg/m}^3\text{)}$$

The density limit of refrigerant which is used in multi air conditioners is 0.3 kg/m³ (ISO 5149).

NOTE

1. If there are 2 or more refrigerating systems in a single refrigerating device, the amount of refrigerant should be as charged in each independent device.

For the amount of charge in this example:

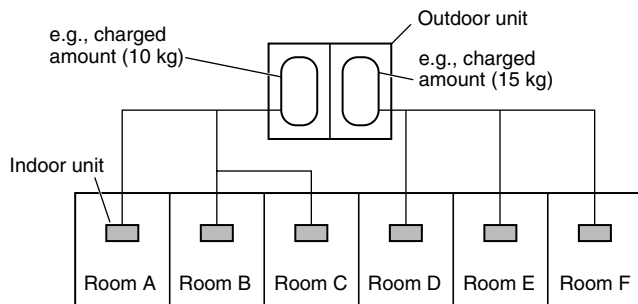

The possible amount of leaked refrigerant gas in rooms A, B and C is 10 kg.

The possible amount of leaked refrigerant gas in rooms D, E and F is 15 kg.

2. The standards for minimum room volume are as follows.

- (1) No partition (shaded portion)

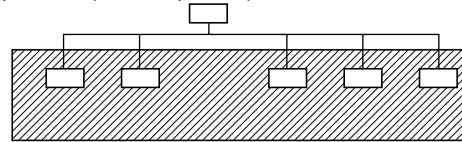

- (2) When there is an effective opening with the adjacent room for ventilation of leaking refrigerant gas (opening without a door, or an opening 0.15% or larger than the respective floor spaces at the top or bottom of the door).

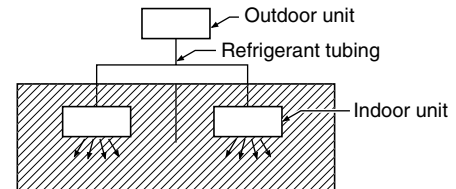

- (3) If an indoor unit is installed in each partitioned room and the refrigerant tubing is interconnected, the smallest room of course becomes the object. But when mechanical ventilation is installed interlocked with a gas leakage detector in the smallest room where the density limit is exceeded, the volume of the next smallest room becomes the object.

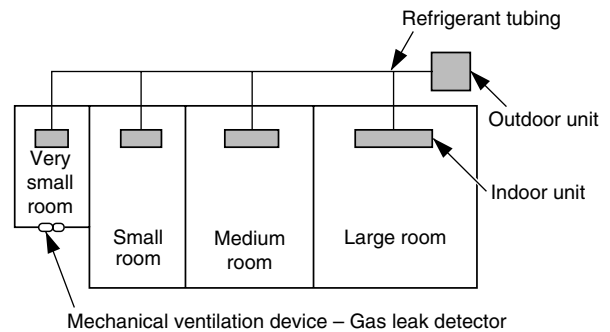

3. The minimum indoor floor space compared with the amount of refrigerant is roughly as follows (for room with 2.7 m high ceiling):

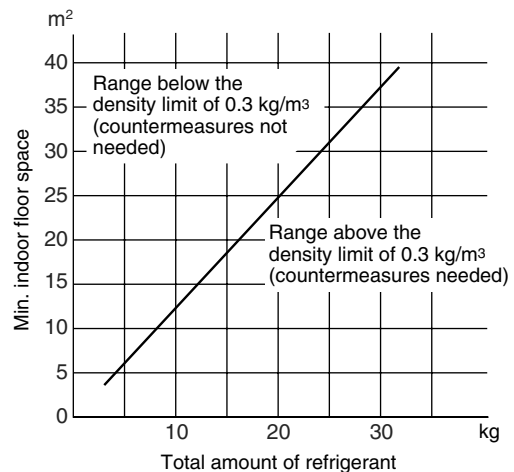

Precautions for Installation Using New Refrigerant

1. Care regarding tubing

1-1. Process tubing

- Material: Use C1220 phosphorous deoxidized copper specified in JIS H3300 "Copper and Copper Alloy Seamless Pipes and Tubes".
- **Tubing size: Be sure to use the sizes indicated in the table below.**
- Use a tube cutter when cutting the tubing, and be sure to remove any flash. This also applies to distribution joints (optional).
- When bending tubing $\phi 15.88$ or smaller, use a bending radius that is 4 times the outer diameter of the tubing or larger.

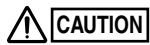

Use sufficient care in handling the tubing. Seal the tubing ends with caps or tape to prevent dirt, moisture, or other foreign substances from entering. These substances can result in system malfunction.

Unit: mm

Material		O			
Copper tube	Outer diameter	6.35	9.52	12.7	15.88
	Wall thickness	0.8	0.8	0.8	1.0

1-2. Prevent impurities including water, dust and oxide from entering the tubing. Impurities can cause R410A refrigerant deterioration and compressor defects. Due to the features of the refrigerant and refrigerating machine oil, the prevention of water and other impurities becomes more important than ever.

2. Be sure to recharge the refrigerant only in liquid form.

- 2-1. Since R410A is a non-azeotrope, recharging the refrigerant in gas form can lower performance and cause defects of the unit.
- 2-2. Since refrigerant composition changes and performance decreases when gas leaks, collect the remaining refrigerant and recharge the required total amount of new refrigerant after fixing the leak.

3. Different tools required

- 3-1. Tool specifications have been changed due to the characteristics of R410A. Some tools for R22- and R407C-type refrigerant systems cannot be used.

Item	New tool?	R407C tools compatible with R410A?	Remarks
Manifold gauge	Yes	No	Types of refrigerant, refrigerating machine oil, and pressure gauge are different.
Charge hose	Yes	No	To resist higher pressure, material must be changed.
Vacuum pump	Yes	Yes	Use a conventional vacuum pump if it is equipped with a check valve. If it has no check valve, purchase and attach a vacuum pump adapter.
Leak detector	Yes	No	Leak detectors for CFC and HCFC that react to chlorine do not function because R410A contains no chlorine. Leak detectors for HFC134a can be used for R410A.
Flaring oil	Yes	No	For systems that use R22, apply mineral oil (Suniso oil) to the flare nuts on the tubing to prevent refrigerant leakage. For machines that use R407C or R410A, apply synthetic oil (ether oil) to the flare nuts.

* Using tools for R22 and R407C and new tools for R410A together can cause defects.

Manifold gauge

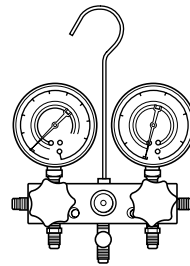

Vacuum pump

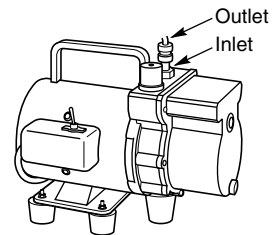

3-2. Use R410A exclusive cylinder only.

Single-outlet valve

(with siphon tube)
Liquid refrigerant should be recharged with the cylinder standing on end as shown.

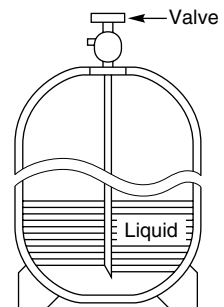

CONTENTS

	Page
IMPORTANT!	2
Please Read Before Starting	
Check of Density Limit	
Precautions for Installation Using New Refrigerant	
1. GENERAL	7
1-1. Tools Required for Installation (not supplied)	
1-2. Accessories Supplied with Unit	
1-3. Type of Copper Tube and Insulation Material	
1-4. Additional Materials Required for Installation	
1-5. Tubing Size	
1-6. Optional Distribution Joint Kits	
1-7. Installing Distribution Joint Kit (for Twin & Double-Twin) (NRF-DL16R)	
1-8. Installing Distribution Joint Kit (for Triple) (NRF-DL28R)	
2. SELECTING THE INSTALLATION SITE	13
2-1. Indoor Unit	
2-2. Outdoor Unit	
2-3. Air Discharge Chamber for Top Discharge	
2-4. Installing the Unit in Heavy Snow Areas	
2-5. Precautions for Installation in Heavy Snow Areas	
2-6. Dimensions of Snow / Wind-proof Ducting and Refrigerant Tubing Space for Installation	
3. HOW TO INSTALL THE INDOOR UNIT	16
■ 4-Way Air Discharge Semi-Concealed Type (4WK Type)	16
3-1. Preparation for Ceiling Suspension	
3-2. Mounting the Suspension Bolts	
3-3. Placing the Unit Inside the Ceiling	
3-4. Installing the Drain Piping	
3-5. Checking the Drainage	
■ Wall-Mounted Type (HW Type)	18
3-6. Removing the Rear Panel from the Unit	
3-7. Selecting and Making a Hole	
3-8. Attaching the Rear Panel onto the Wall	
3-9. Removing the Grille to Install the Indoor Unit	
3-10. Preparing the Tubing	
3-11. Shaping the Tubing	
3-12. Installing the Drain Hose	
■ Ceiling-Mounted Type (C Type)	22
3-13. Required Minimum Space for Installation and Service	
3-14. Suspending the Indoor Unit	
3-15. Duct for Fresh Air	
3-16. Shaping the Tubing	
3-17. Installing the Drain Pipe	
■ Concealed-Duct Type (D Type)	26
3-18. Required Minimum Space for Installation and Service	
3-19. Suspending the Indoor Unit	
3-20. Installing the Drain Pipe	
3-21. Checking the Drainage	
3-22. Increasing the Fan Speed	
3-23. When Installing the Indoor Unit	
3-24. Required Minimum Space for Installation and Service	
■ SUPPLEMENT ON DRAIN PIPING	31
4. HOW TO INSTALL THE OUTDOOR UNIT	32
4-1. Installing the Outdoor Unit	
4-2. Drainage Work	
4-3. Routing the Tubing and Wiring	
5. ELECTRICAL WIRING	33
5-1. General Precautions on Wiring	
5-2. Recommended Wire Length and Wire Diameter for Power Supply System	
5-3. Wiring System Diagrams	
6. HOW TO INSTALL THE TIMER REMOTE CONTROLLER (OPTIONAL PART)	36
NOTE	
Refer to the Instruction Manual attached to the optional Timer Remote Control Unit.	
7. HOW TO PROCESS TUBING	36
7-1. Connecting the Refrigerant Tubing	
7-2. Connecting Tubing Between Indoor and Outdoor Units	
7-3. Insulating the Refrigerant Tubing	
7-4. Taping the Tubes	
7-5. Finishing the Installation	
8. LEAK TEST, EVACUATION AND ADDITIONAL REFRIGERANT CHARGE	39
■ Air Purging with a Vacuum Pump (for Test Run) Preparation	39
8-1. Leak Test	
8-2. Evacuation	
8-3. Charging Additional Refrigerant	
8-4. Finishing the Job	

	Page
9. HOW TO INSTALL THE CEILING PANEL	41
■ 4-Way Air Discharge Semi-Concealed Type (4WK Type)	41
9-1. Before Installing the Ceiling Panel	
9-2. Installing the Ceiling Panel	
9-3. Wiring the Ceiling Panel	
9-4. How to Attach the Corner and Air Intake Grille	
9-5. Checking After Installation	
9-6. When Removing the Ceiling Panel for Servicing	
9-7. Adjusting the Auto Flap	
10. TEST RUN	44
10-1. Preparing for Test Run	
■ 4WK, C, D Types	44
10-2. Caution	
10-3. Test Run Procedure	
10-4. Items to Check Before the Test Run	
10-5. Test Run Using the Remote Controller	
10-6. Precautions	
10-7. Table of Self-Diagnostic Functions and Corrections (4WK, C, D Types)	
10-8. System Control	
■ HW Type	50
10-9. Caution	
10-10. Test Run Procedure	
10-11. Items to Check Before the Test Run	
10-12. Preparation for Test Run	
10-13. Test Run	
10-14. Precautions	
10-15. Table of Self-Diagnostic Functions and Corrections	
10-16. System Control	
■ 4WK, C, D Types (for Link Wiring)	57
10-17. Caution	
10-18. Test Run Procedure	
10-19. Items to Check Before the Test Run	
10-20. Test Run Using the Remote Controller	
10-21. Table of Self-Diagnostic Functions and Corrections (4WK, C, D Types)	
10-22. Automatic Address Setting	
■ HW Type (for Link Wiring)	62
10-23. Caution	
10-24. Test Run Procedure	
10-25. Table of Self-Diagnostic Functions and Corrections (HW Type)	
10-26. Automatic Address Setting	
10-27. Caution for Pump Down	

	Page
11. HOW TO INSTALL WIRELESS REMOTE CONTROLLER RECEIVER	68
NOTE	
Refer to the Instruction Manual attached to the Optional Wireless Remote Controller Receiver.	
12. MARKINGS FOR DIRECTIVE 97/23/EC (PED)	68
13. APPENDIX	69
13-1. 4-Way Air Discharge Semi-Concealed Type (4WK Type)	
13-2. Concealed Duct Type (D Type)	
13-3. Ceiling-Mounted Type (C Type)	
13-4. Wall-Mounted Type (HW Type)	

1. General

This booklet briefly outlines where and how to install the air conditioning system. Please read over the entire set of instructions for the indoor and outdoor units and make sure all accessory parts listed are with the system before beginning.

1-1. Tools Required for Installation (not supplied)

1. Flathead screwdriver
2. Phillips head screwdriver
3. Knife or wire stripper
4. Tape measure
5. Carpenter's level
6. Sabre saw or key hole saw
7. Hacksaw
8. Core bits
9. Hammer
10. Drill
11. Tube cutter
12. Tube flaring tool
13. Torque wrench
14. Adjustable wrench
15. Reamer (for deburring)

1-2. Accessories Supplied with Unit

See Tables 1-1 to 1-4.

Table	Type
1-1	4-Way Air Discharge Semi-Concealed
1-2	Wall-Mounted
1-3	Ceiling-Mounted
1-4	Concealed-Duct

1-3. Type of Copper Tube and Insulation Material

If you wish to purchase these materials separately from a local source, you will need:

1. Deoxidized annealed copper tube for refrigerant tubing.
2. Foamed polyethylene insulation for copper tubes as required to precise length of tubing. Wall thickness of the insulation should be not less than 8 mm.
3. Use insulated copper wire for field wiring. Wire size varies with the total length of wiring. Refer to 5. ELECTRICAL WIRING for details.



Check local electrical codes and regulations before obtaining wire. Also, check any specified instructions or limitations.

1-4. Additional Materials Required for Installation

1. Refrigeration (armored) tape
2. Insulated staples or clamps for connecting wire (See your local codes.)
3. Putty
4. Refrigeration tubing lubricant
5. Clamps or saddles to secure refrigerant tubing
6. Scale for weighing

Table 1-1 (4-Way Air Discharge Semi-Concealed)

Part Name	Figure	Q'ty	Remarks
Full-scale installation diagram		1	Printed on container box
Flare insulator		2	For gas and liquid tubes
Insulating tape		2	For gas and liquid tube flare nuts
Hose band		1	For securing drain hose
Packing		1	For drain joint
Drain insulator		1	For drain joint
Drain hose		1	For securing drain hose
Washer		8	For suspension bolts
Screw		4	For full-scale installation diagram

Table 1-2 (Wall-Mounted)

Part Name	Figure	Q'ty	Remarks
Plastic cover		1	For improved tubing appearance
Tapping screw	Truss-head Phillips 4 x 16 mm 	10	For fixing the rear panel
Insulator		1	For insulating flare nut (254 type only)

Table 1-3 (Ceiling-Mounted)











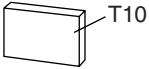
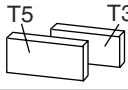



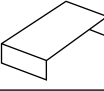

Part Name	Figure	Q'ty	Remarks
Special washer		4	For temporarily suspending indoor unit from ceiling
Drain insulator		1	For drain hose joint
Flare insulator		2 sets	For gas and liquid tube joints
Insulating tape	 White (heat-resisting)	2	For gas and liquid flare joints
Vinyl clamp		8	For flare and drain insulator (Field supply for Spanish version)
Eyelet		1	For power supply inlet
Full-scale installation diagram		1	Printed on container box
Drain hose		1	For main unit + PVC pipe joints
Hose band		2	For drain hose connection

Table 1-4 (Concealed-Duct)

Part Name	Figure	Q'ty	Remarks
Washer		8	For suspending indoor unit from ceiling
Flare insulator		2	For gas and liquid tubes
Insulating tape		2	For gas and liquid tubes flare nuts
Dain insulator		1	For drain hose joint
Hose band		1	For securing drain hose
Packing		1	For drain joint
Drain hose		1	
Sealing putty		1	For sealing recessed portion of power supply
Vinyl clamp		8	For flare and drain insulators (Field supply for Spanish version)
Booster cable*		1	Connector for changeover to HT tap

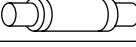
* Booster cable is housed inside the electrical component box.

- Use M10 or 3/8" suspension bolts.
- Suspension bolts and nuts are field supply.

1-5. Tubing Size

(A) Single type

- Refrigerant tubing between the indoor and outdoor units should be kept as short as possible.
- The lengths of the refrigerant tubes between the indoor and outdoor units are limited by the elevation difference between the 2 units. During tubing work, try to make both the tubing length (L) and the difference in elevation (H1) as short as possible. Refer to Table 1-5.

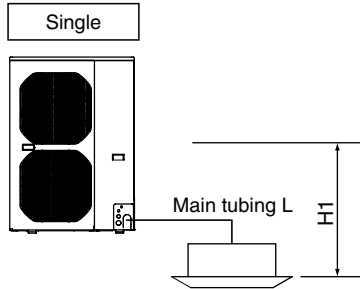

Table 1-5

Outdoor unit type	18 type
Maximum allowable tubing length	40 m
Charge-less tubing length (actual length)	3 – 30 m
Additional charge per 1 m	20 g
Outdoor unit type	25, 36 types
Maximum allowable tubing length	50 m
Charge-less tubing length (actual length)	3 – 30 m
Additional charge per 1 m	40g
Outdoor unit type	48, 60 types
Maximum allowable tubing length	50 m
Charge-less tubing length (actual length)	5 – 30 m
Additional charge per 1 m	40g

(B) Simultaneous operation multi (Twin, Triple, Double-Twin)

NOTE

Because the indoor units run simultaneously, install them within the same room.

Table 1-6

Item	Contents	Symbol				Actual length (m)
		Single	Twin	Triple	Double-Twin	
Allowable tubing lengths	Maximum allowable tubing length	L	L + l1 L + l2	L + l1, L + l2 L + l3	L + L1 + l1, L + L1 + l2 L + L2 + l3, L + L2 + l4	≤50
	Maximum distribution tubing length	-	l1, l2	l1, l2, l3	L1 + l1, L1 + l2 L2 + l3, L2 + l4	≤15
Maximum branch tubing length	Difference between the maximum length and minimum length in tubing following the first branch point	-	l1 > l2 l1 - l2	l1 > l2 > l3 l1 - l2 l1 - l3 l2 - l3	Max: L2 + l4 Min: L1 + l1 (L2 + l4) - (L1 + l1)	≤10
Maximum difference between lengths of No. 1 distribution tubing (double twin)		-	-	-	L2 > L1 L2 - L1	≤10
Maximum difference between lengths of No. 2 distribution tubing (double twin)		-	-	-	l2 > l1, l4 > l3 l2 - l1, l4 - l3	≤10
Maximum allowable height difference	Maximum indoor-outdoor height difference	If outdoor unit is higher	H1			≤30
		If outdoor unit is lower	H1			≤15
	Maximum height difference between indoor units	-	H2	H2, H3, H4	H2, H3, H4, H5, H6, H7	≤0.5

* For connection tubing sizes, refer to Table 1-6 above.

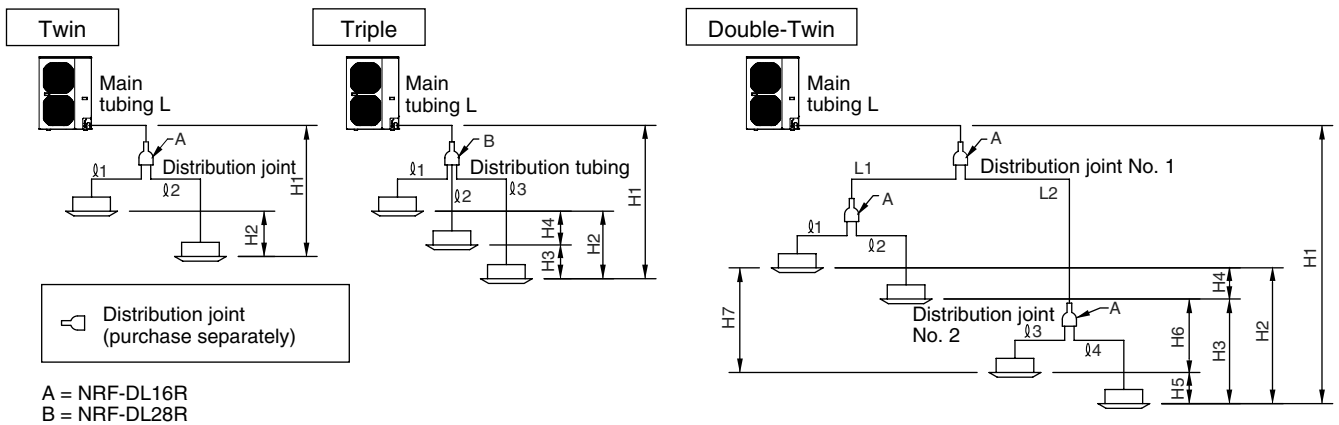

NOTE

- For refrigerant tube branches, use the optional distribution joints.
- For cautions on the use of the optional distribution joints, be sure to refer to the provided instruction sheet. Also, be careful to install them in the correct direction (orientation).

Table 1-7 Tubing Data for Models (Single, Twin, Triple, Double-Twin)

Tubing Data		Models	OU-PSINV-25HR	OU-PSINV-36HR	OU-PSINV-48HR	OU-PSINV-60H
Tubing size outer diameter	Liquid tube mm (in.)		9.52 (3/8)	9.52 (3/8)	9.52 (3/8)	9.52 (3/8)
	Gas tube mm (in.)		15.88 (5/8)	15.88 (5/8)	15.88 (5/8)	15.88 (5/8)
Limit of tubing length		(m)	50	50	50	50
Limit of elevation difference between the 2 units	Outdoor unit is placed higher	(m)	30	30	30	30
	Outdoor unit is placed lower	(m)	15	15	15	15
Max. allowable tubing length at shipment		(m)	3 – 30	3 – 30	5 – 30	5 – 30
Required additional refrigerant		(g/m)	40 *2	40 *2	40 *2	40 *2
Refrigerant charged at shipment		(kg)	1.9	2.8	3.6	3.6

No additional charge of compressor oil is necessary.

*1 If total tubing length becomes 30 to 40 m, charge additional refrigerant by 20 g/m.

*2 If total tubing length becomes 30 to 50 m, charge additional refrigerant by 40 g/m.

Table 1-8 Connection Tube Sizes

	Main tubing (L)	Double-Twin distribution tube (L1, L2)		Indoor unit connection tube (l1, l2, l3, l4)	
		Total type capacity of indoor unit connected after the branch			
Type capacity of indoor unit	25 – 60	25		25 – 60	12 – 18
Gas tube	ø15.88	ø15.88		ø15.88	ø12.7
Liquid tube	ø9.52	ø9.52		ø9.52	ø6.35
Amount of additional charge per 1 m	40 g	40 g		40 g	20 g

Charge with the amount of additional refrigerant calculated using the formula below, based on the values in Table 1-8 and the size and length of the liquid tubing.

Amount of additional refrigerant charge (g)

Do not remove refrigerant from the system, even if the result of the calculation is negative.

$$\begin{aligned} \text{Additional refrigerant amount (g)} &= \text{Additional refrigerant for main tubing (g)} + \text{Additional refrigerant for distribution tubing (g)} \\ &\quad - \text{Outdoor unit charge-less refrigerant amount (g)} \\ &= 40X (a) + 40X (b) + 20X (c) - 1200 \text{ (25 – 60 type)} \end{aligned}$$

(Use with the current refrigerant charge.)

(a) Actual length (m) of main tubing (ø9.52)

Refrigerant charge per 1 m of actual length = 40 g/m (25 – 60 type)

(b) Total length of distribution tubing (ø9.52)

Refrigerant charge per 1 m of actual length = 40 g/m

(c) Total length of distribution tubing (ø6.35)

Refrigerant charge per 1 m of actual length = 20 g/m

Example

● Sample tubing lengths

- L = 35 m l1 = 5 m
- L1 = 10 m l2 = 5 m
- L2 = 5 m l3 = 5 m
- l4 = 10 m

● Find the liquid tube size from Table 1-8.

- L : ø9.52 (48 type)
- L1 : ø9.52 (Total type capacity of indoor unit 24)
- L2 : ø9.52 (Total type capacity of indoor unit 24)
- l1 – l4 : ø6.35

● The amount of additional on-site refrigerant charge is found by subtracting the outdoor unit charge-less refrigerant amount from the total charge amount for all tube sizes.

- ø9.52 → L : 35 m × 40 g / m = 1400
- ø9.52 → L1 + L2 : (10 + 5) m × 40 g / m = 600
- ø6.35 → l1 – l4 : (5 + 5 + 5 + 10) m × 20 g / m = 500
- Outdoor unit charge-less refrigerant amount -1200

Total +1300

● The amount of additional on-site refrigerant charge is 1,300 g.

Note: For type 18, the additional refrigerant charge for tubing length (d) of 30 to 40 m is the following:

$$\text{Additional refrigerant amount (g)} = 20X (d) - 600$$

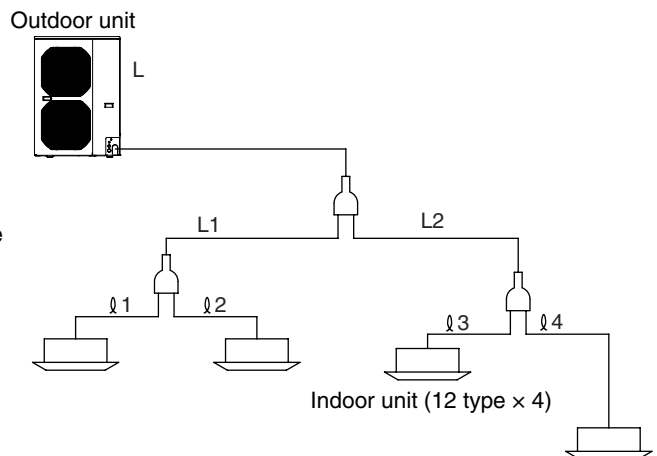

CAUTION

1. This unit requires no additional refrigerant charge up to tubing length 30 m. In case of more than 30 m, additional refrigerant charge is required. Refer to Tables 1-7 and 1-8.
2. In case of multi type installation, indoor units should be installed within the same room. If multi type indoor units are installed in different rooms, temperature control may develop problems because thermostat operation must follow the thermostat condition of 1 indoor unit only (the main unit).

WARNING

Always check the gas density for the room in which the unit is installed.

Check of limit density

When installing an air conditioner in a room, it is necessary to ensure that even if the refrigerant gas accidentally escapes, its density does not exceed the limit level.

If the density might exceed the limit level, it is necessary to set up an opening between it and the adjacent room, or to install mechanical ventilation which is interlocked with the leak detector.

(Total refrigerant charged amount: kg)

(Min. indoor volume where indoor unit is installed: m³)
 \leq Limit density 0.3 (kg/m³)

The limit density of refrigerant which is used in this unit is 0.3 kg/m³ (ISO 5149).

The shipped outdoor unit comes charged with the amount of refrigerant fixed for each type, so add it to the amount that is charged at the field. (Refer to the unit's nameplate for the amount of charged refrigerant at shipment.)

Minimum indoor volume & floor area relative to the amount of refrigerant are roughly as given in the following table.

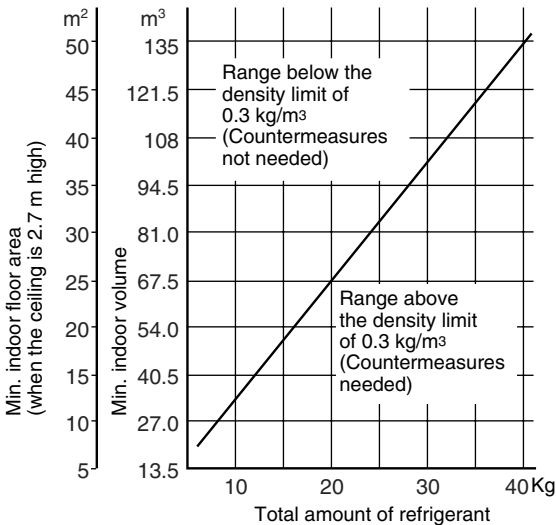

CAUTION

Pay special attention to any location, such as a basement or recessed area, etc. where leaked refrigerant can collect, since refrigerant gas is heavier than air.

1-6. Optional Distribution Joint Kits

- NRF-DL16R: Cooling capacity after distribution is 16.0 kW (54,600 BTU/h) or less.
- NRF-DL28R: Cooling capacity after distribution is 28.0 kW (95,500 BTU/h) or less.

Table 1-9 Distribution Branch Size (ℓ1, ℓ2, ℓ3, ℓ4)

Unit: mm (in.)

Indoor Unit	12 type	16 type	18 type
Gas tube	12.7 (1/2)		
Liquid tube	6.53 (1/4)		

Indoor Unit	25 type	36 type	48 type	60 type
Gas tube	15.88 (5/8)			
Liquid tube	9.52 (3/8)			

NRF-DL16R

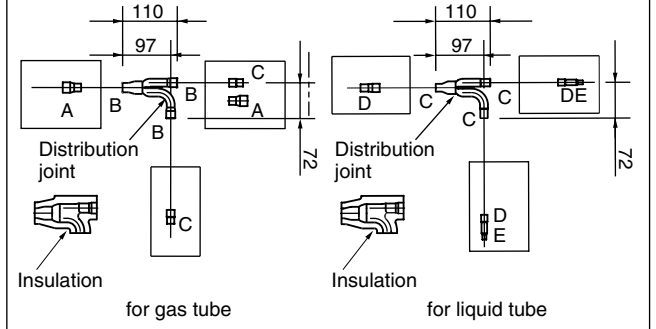
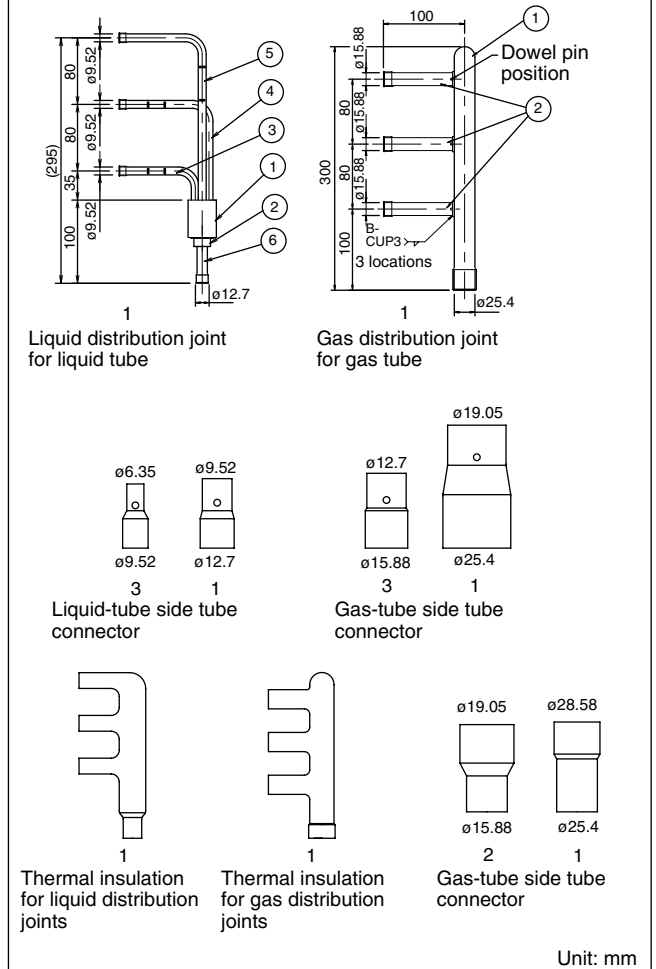

Table 1-10 Size of connection point on each part (shown is inside diameter of tubing)

Size	Part A	Part B	Part C	Part D	Part E
mm	ø19.05	ø15.88	ø12.7	ø9.52	ø6.35

Unit: mm

NRF-DL28R (for simultaneous Triple)



Unit: mm

1-7. Installing Distribution Joint Kit (for Twin & Double-Twin) (NRF-DL16R)

- Use a tube cutter and cut at the size position that corresponds to the field-supply tube size selected based on the total indoor unit capacity. (If the size is the same as the tube end size, cutting is not necessary.)
- If the reducer that was supplied in the package is used, perform brazing on-site.
 Note: Do not cut in such a way that applies excessive force and causes deformation of the tube. (This will prevent insertion of the connecting tube.)
 For size selection, refer to "Information for the Person in Charge of Installation" and other materials that were supplied with the outdoor unit.

- Cut at a position that is as far away as possible from the dowel pin.
- After cutting the tube, be sure to remove any burrs and to finish the end surface correctly. (If there is excessive crushing or indentation of the tube, use a tube expander to expand it.)
- Check that there is no dirt or other foreign substance inside the distribution tubing.
- Install the distribution tubing so that it is either horizontal or vertical.
- Use the supplied thermal insulation to insulate the distribution tubing. (If other insulation is used, be sure to use insulation that can withstand temperatures of at least 120°C.)
- For details, refer to "Information for the Person in Charge of Installation".

If the distribution joint will be cut before use, cut on the line marked "cutting point" in the figure below.

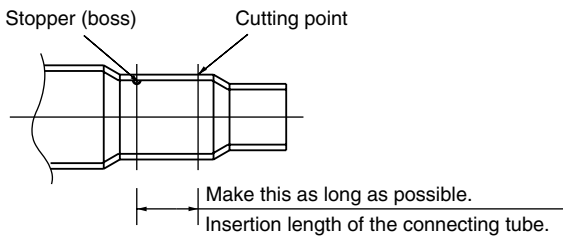

Horizontal Installation

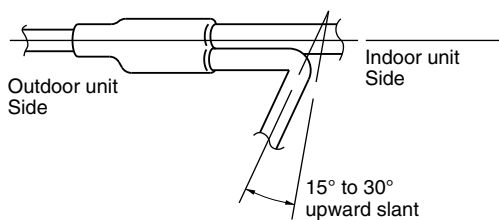

Vertical installation (directed upward or downward)

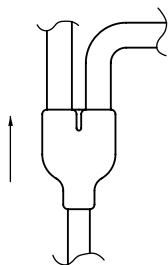

Nitrogen gas replacement required for tube brazing

If nitrogen replacement is not done when brazing is performed on the indoor and outdoor unit refrigerant tubing, oxide scale will occur. This scale will clog the solenoid valves, strainers, and other parts, leading to malfunction.

Therefore be sure to replace the air in the tubing with nitrogen when performing brazing in order to prevent problems from oxide scale.

1-8. Installing Distribution Joint Kit (for Triple) (NRF-DL28R)

- Check the system combination before installing the distribution joints.
- Three indoor units must be installed within the same room.
- Use the supplied tube connectors to adjust the tube sizes of the distribution joints.

How to Install Distribution Joints

Use the supplied distribution joints to complete refrigerant tubing work.

Install distribution joints so that the tubes are horizontal after the branch point.

Orientation of distribution joints

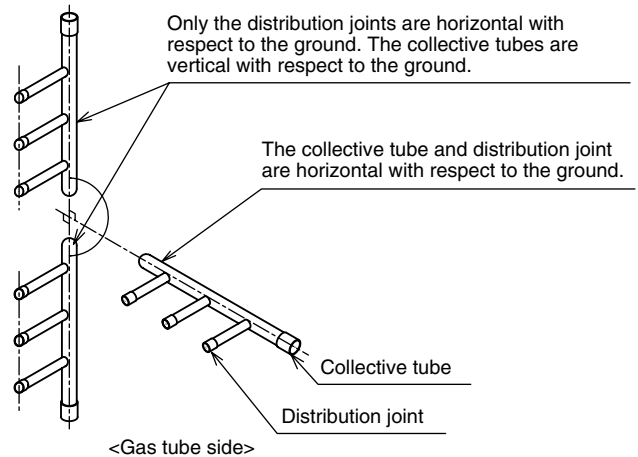

Length requirement for strainer on main distribution tube side

Attach a straight tube 500 mm or longer to the main tubing side of the distribution joint (for both liquid and gas tubing).

Tubing insulation

Be sure to apply thermal insulation to both the liquid and gas tubing. Depending on the conditions inside the ceiling, condensation may form on the insulation material. If high temperatures and high humidity are expected to occur inside the ceiling, add glass wool (16 – 20 kg/m³, with a thickness of 10 mm or more) to the below insulation materials and apply sufficient thermal insulation.

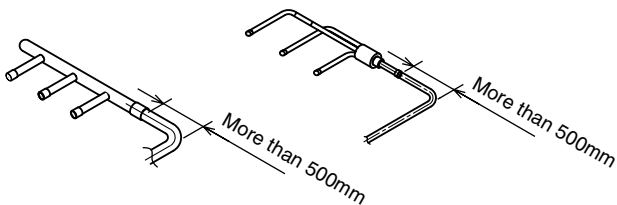
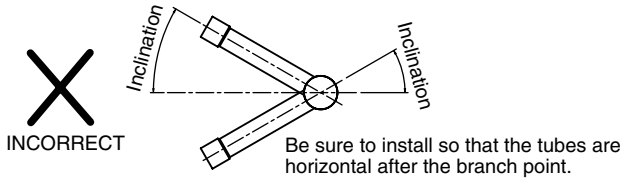
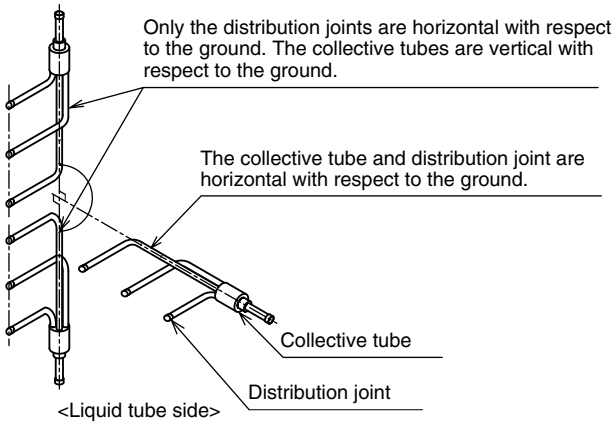

- Distribution joint insulation material (supplied)
- Use the supplied insulation material.
 - The supplied insulation material include only a tape for temporarily fastening.
 - Use insulation material or other material to seal the joining lines so that there are no gaps.
 - Use vinyl tape or similar means to seal and fasten the insulation materials in place.

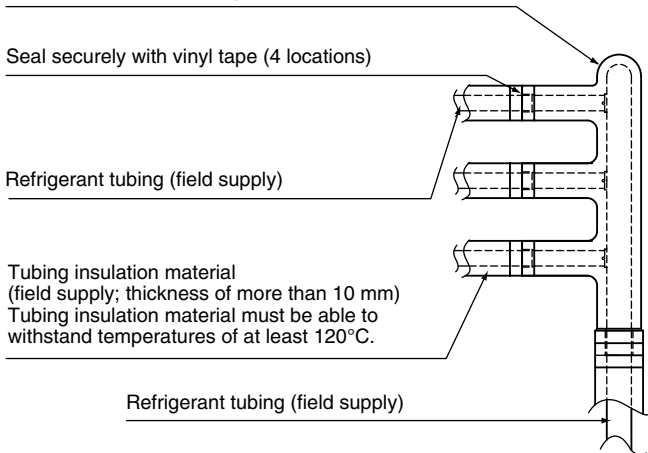

2. Selecting the Installation Site

2-1. Indoor Unit



- When moving the unit during or after unpacking, make sure to lift it by holding its lifting lugs. Do not exert any pressure on other parts, especially the refrigerant piping, drain piping and flange parts.
- If you think the humidity inside the ceiling might exceed 30°C and RH 80%, reinforce the insulation on the unit body. Use glass wool or polyethylene foam as insulation so that it is no thicker than 10 mm and fits inside the ceiling opening.

AVOID:

- areas where leakage of flammable gas may be expected.
- places where large amounts of oil mist exist.
- direct sunlight.
- locations near heat sources which may affect the performance of the unit.
- locations where external air may enter the room directly. This may cause "condensation" on the air discharge ports, causing them to spray or drip water.
- locations where the remote controller will be splashed with water or affected by dampness or humidity.
- installing the remote controller behind curtains or furniture.
- locations where high-frequency emissions are generated.
- places where blocks air passages.
- places where the false ceiling is not noticeably on an incline.

DO:

- select an appropriate position from which every corner of the room can be uniformly cooled.
- select a location where the ceiling is strong enough to support the weight of the unit.
- select a location where tubing and drain pipe have the shortest run to the outdoor unit.
- allow room for operation and maintenance as well as unrestricted airflow around the unit.
- install the unit within the maximum elevation difference above or below the outdoor unit and within a total tubing length (L) from the outdoor unit as detailed in Tables 1-5 and 1-7.
- allow room for mounting the remote controller about 1m off the floor, in an area that is not in direct sunlight or in the flow of cool air from the indoor unit.
- places where optimum air distribution can be ensured.
- places where sufficient clearance for maintenance and service can be ensured. (See the next page.)

2-2. Outdoor Unit

AVOID:

- heat sources and exhaust fans, etc. (Fig. 2-4)
- damp, humid or uneven locations.

DO:

- choose a place as cool as possible.
- choose a place that is well ventilated and outside air temperature does not exceed maximum 45°C constantly.
- allow enough room around the unit for air intake/exhaust and possible maintenance. (Fig. 2-5)
- use lug bolts or equal to bolt down unit, reducing vibration and noise.
- If cooling operation is to be used when the outdoor air temperature is -5°C or below, install a duct on the outdoor unit.

Ceiling-Mounted Type

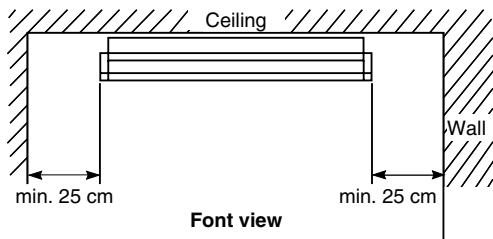

NOTE

The rear of the indoor unit can be installed flush against the wall.

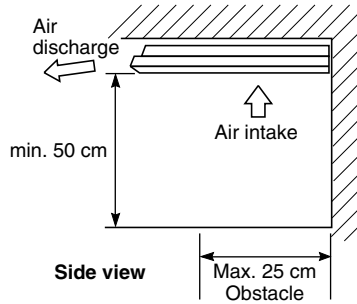

Fig. 2-1

Concealed-Duct Type / 4-Way Semi-Concealed Type

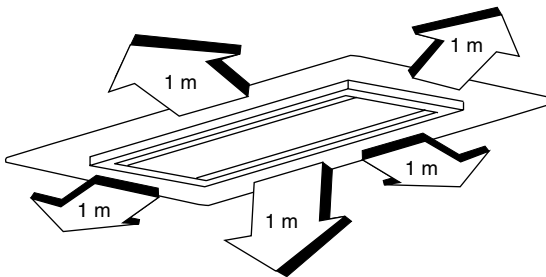

Fig. 2-2

Wall-Mounted Type

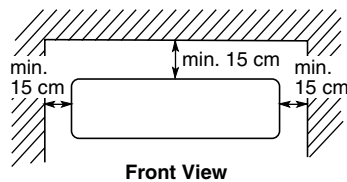

Fig. 2-3

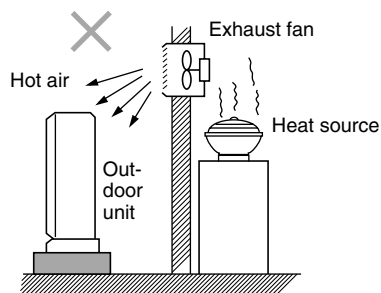

Fig. 2-4

Installation space

For 3, 4, 5 and 6 HP Outdoor Unit

Distance between obstructions and the unit air inlet and outlet must be as shown below.

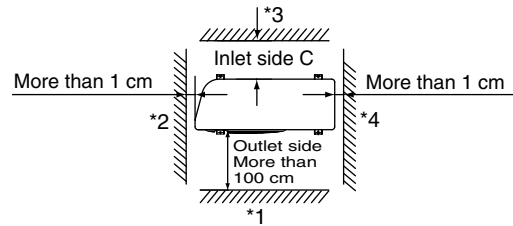

Fig. 2-5

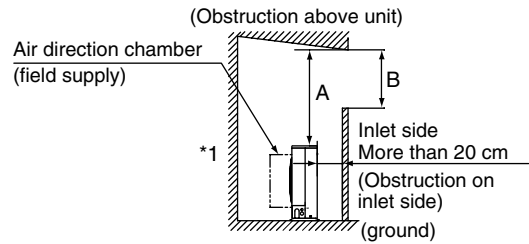

Fig. 2-6

NOTE

- Concerning inlet-side distance "C" (Fig. 2-5)
The minimum for distance "C" is 15 cm if there are no obstructions on the outlet side (wall *1 side) and *2 or *4 is not present. In all other cases, the minimum for distance "C" is 20 cm.
- If the unit is installed with the outlet side facing wall *1, then there must be no obstructions on 2 of the remaining 3 sides: *2, *3, *4.
- If wall *1 is on the outlet side (Fig. 2-5), or if obstructions are present on all 3 sides *2, *3, and *4 (Fig. 2-5), then the minimum distance for "A" and "B" is 2 m (Fig. 2-6). Even if there is no wall on the outlet side, a minimum of 100 cm is required.

In case of multiple installations

- Provide a solid base (concrete block, 10 × 40 cm beams or equal), a minimum of 15 cm above ground level to reduce humidity and protect the unit against possible water damage and decreased service life. (Fig. 2-7)
- Use lug bolts or equal to bolt down unit, reducing vibration and noise.

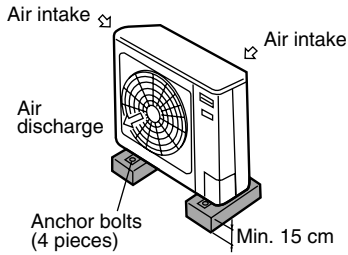

Fig. 2-7

2-3. Air Discharge Chamber for Top Discharge

Be sure to install the air discharge chamber in the field when:

- it is difficult to keep a space of min. 50 cm between the air discharge outlet and an obstacle.
- the air discharge outlet is facing a sidewalk and discharged hot air annoys passers-by. (Fig. 2-8)

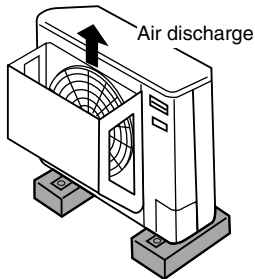

Fig. 2-8

2-4. Installing the Unit in Heavy Snow Areas

In locations with strong wind, snow-proof ducting should likewise be fitted and direct exposure to the wind should be avoided as much as possible.

■ Countermeasures against snow and wind

In regions with snow and strong wind, the following problems may occur when the outdoor unit is not provided with a platform and snow-proof ducting:

- The outdoor fan may not run and damage of the unit may be caused.
- There may be no airflow.
- The tubing may freeze and burst.
- The condenser pressure may drop because of strong wind, and the indoor unit may freeze.

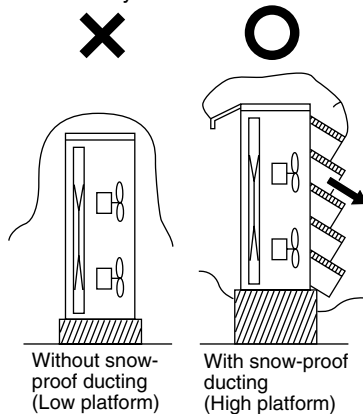

Fig. 2-9

In regions with significant snowfall, the outdoor unit should be provided with a platform and snow-proof duct.

2-5. Precautions for Installation in Heavy Snow Areas

- (1) The platform should be higher than the max. snow depth. (Fig. 2-9)
- (2) The 2 anchoring feet of the outdoor unit should be used for the platform, and the platform should be installed beneath the air intake side of outdoor unit.
- (3) The platform foundation must be firm and the unit must be secured with anchor bolts.
- (4) In case of installation on a roof subject to strong wind, countermeasures must be taken to prevent the unit from being blown over.

2-6. Dimensions of Snow / Wind-proof Ducting and Refrigerant Tubing Space for Installation

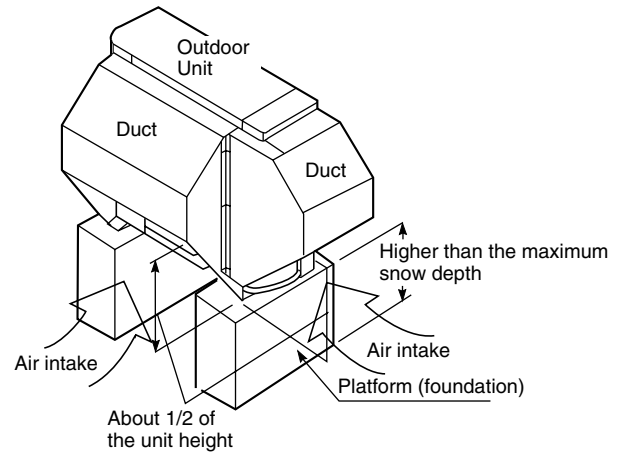
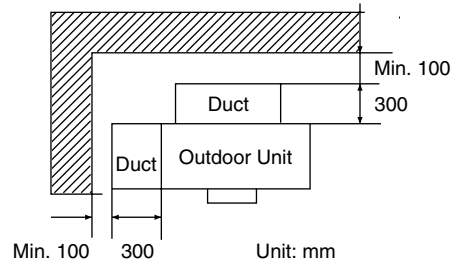

Fig. 2-10

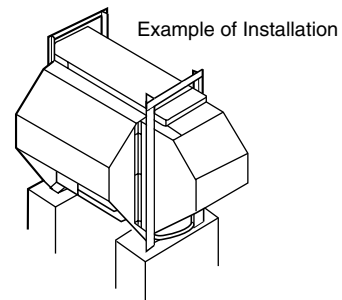

Fig. 2-11

3. How to Install the Indoor Unit

■ 4-Way Air Discharge Semi-Concealed Type (4WK Type)

3-1. Preparation for Ceiling Suspension

This unit uses a drain pump. Use a carpenter's level to check that the unit is level.

3-2. Mounting the Suspension Bolts

- Fix the suspension bolts securely to the ceiling using the method shown in the diagrams (Figs. 3-1 and 3-2), by attaching them to the ceiling support structure, or by any other method that ensures that the unit will be securely and safely suspended.
- Follow Fig. 3-2 and Table 3-1 to make the holes in the ceiling.

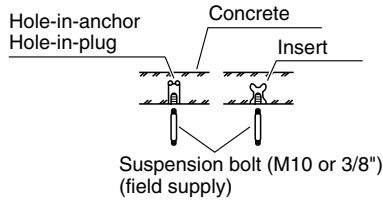
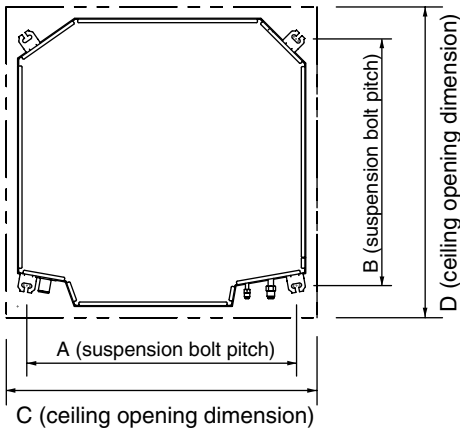

Fig. 3-1



Unit: mm

Fig. 3-2

Table 3-1

Unit: mm

Type \ Length	A	B	C	D
12, 16, 18, 25, 36, 48, 60	788	723	885	885

- Determine the pitch of the suspension bolts using the supplied full-scale installation diagram. The diagram and table (Fig. 3-3 and Table 3-2) show the relationship between the positions of the suspension fitting, the unit, and the panel.

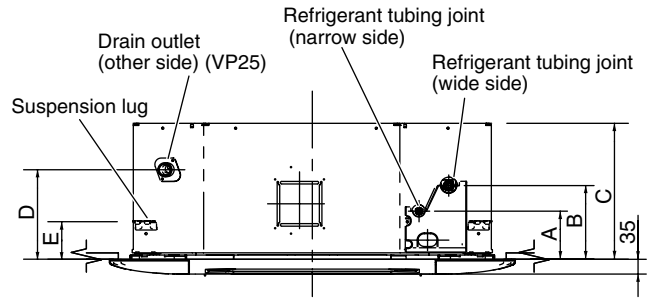

Unit: mm

Fig. 3-3

Table 3-2

Unit: mm

Type \ Length	A	B	C	D	E
12, 16, 18, 25	113	173	256	210	88
36, 48, 60	113	173	319	210	88

3-3. Placing the Unit Inside the Ceiling

- When placing the unit inside the ceiling, determine the pitch of the suspension bolts using the supplied full-scale installation diagram. (Fig. 3-4)
Tubing and wiring must be laid inside the ceiling when suspending the unit. If the ceiling is already constructed, lay the tubing and wiring into position for connection to the unit before placing the unit inside the ceiling.
- The length of suspension bolts must be appropriate for a distance between the bottom of the bolt and the bottom of the unit of more than 15 mm. (Fig. 3-4)

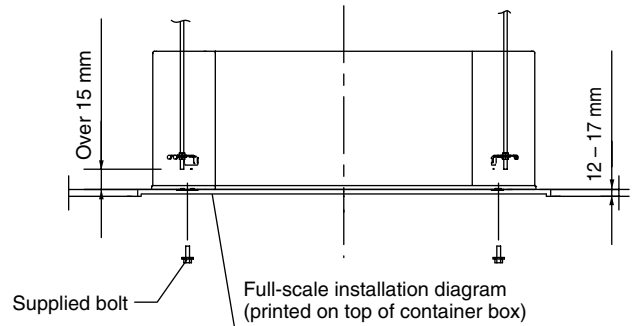

Fig. 3-4

- Thread the 3 hexagonal nuts and 2 washers (field supply) onto each of the 4 suspension bolts (Fig. 3-5). Use 1 nut and 1 washer for the upper side, and 2 nuts and 1 washer for the lower side, so that the unit will not fall off the suspension lugs.

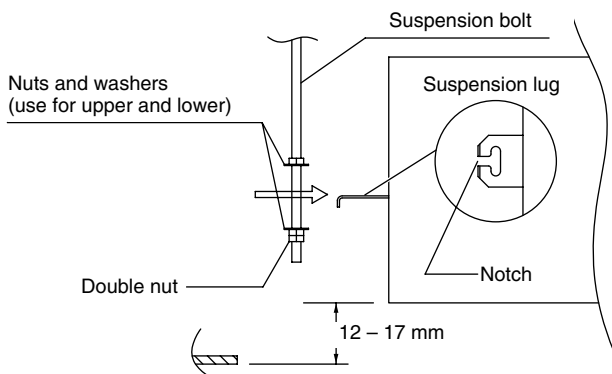

Fig. 3-5

- Adjust so that the distance between the unit and the ceiling bottom is 12 to 17 mm. Tighten the nuts on the upper side and lower side of the suspension lug.
- Remove the protective polyethylene used to protect the fan parts during transport.

3-4. Installing the Drain Piping

- Prepare a standard hard PVC pipe (O.D. 32 mm) for the drain and use the supplied drain hose and hose band to prevent water leaks. The PVC pipe must be purchased separately. The unit's transparent drain port allows you to check drainage. (Fig. 3-6)

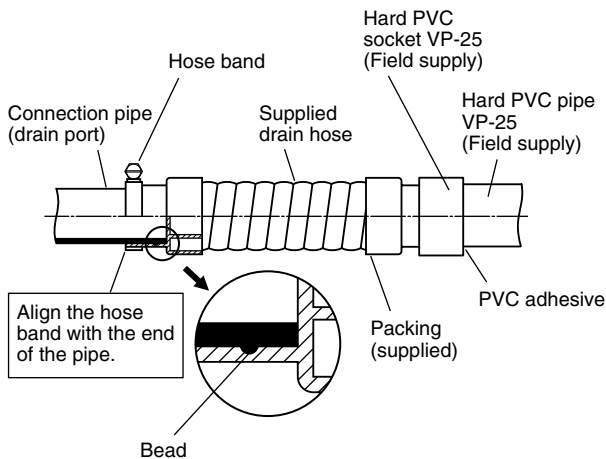

Fig. 3-6

CAUTION

Insert the drain pipe until it contacts the socket as shown in Fig. 3-6, then secure it tightly with the hose band.

- Do not use adhesive when connecting the supplied hose.
 - Reasons: 1. It may cause water to leak from the connection. Since the connection is slippery just after the adhesive has been applied, the pipe easily slips off.
 - 2. The pipe cannot be removed when maintenance is needed.
- Do not bend the supplied drain hose 90° or more. The hose may slip off.

- Align the hose bands with the end of the hose. Tighten the hose band firmly. Make sure that the bead is not covered by the hose band. (Fig. 3-6)

- After checking the drainage, wrap the supplied packing and drain pipe insulator around the pipe. (Fig. 3-7)

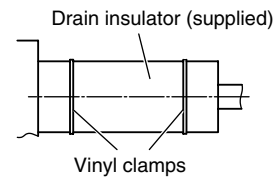

Fig. 3-7

CAUTION

Tighten the hose clamps so their locking nuts face upward. (Fig. 3-6)

NOTE

Make sure the drain pipe has a downward gradient (1/100 or more) and that there are no water traps.

CAUTION

Do not install an air bleeder as this may cause water to spray from the drain pipe outlet. (Fig. 3-8)

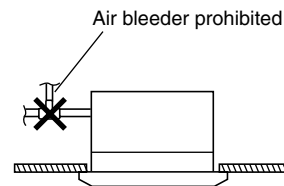

Fig. 3-8

CAUTION

- If it is necessary to increase the height of the drain pipe, the section directly after the connection port can be raised a maximum of 64 cm. Do not raise it any higher than 64 cm, as this could result in water leaks. (Fig. 3-9)
- Do not install the pipe with an upward gradient from the connection port. This will cause the drain water to flow backward and leak when the unit is not operating. (Fig. 3-10)

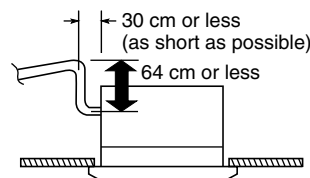

Fig. 3-9

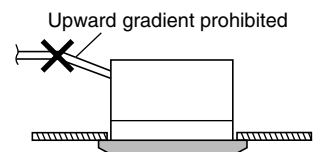

Fig. 3-10

- Do not apply force to the piping on the unit side when connecting the drain pipe. The pipe should not be allowed to hang unsupported from its connection to the unit. Fasten the pipe to a wall, frame, or other support as close to the unit as possible. (Fig. 3-11)

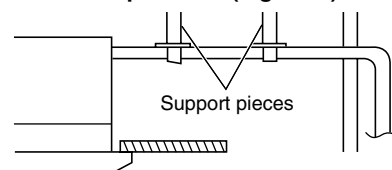

Fig. 3-11

- Provide insulation for any pipes that are run indoors.

NOTE

Refer to the Section "■ SUPPLEMENT ON DRAIN PIPING".

3-5. Checking the Drainage

After wiring and drain piping are completed, use the following procedure to check that the water will drain smoothly. For this, prepare a bucket and wiping cloth to catch and wipe up spilled water.

- (1) Connect power to the power terminal board (R, S terminals) inside the electrical component box.
- (2) Slowly pour about 1,200 cc of water into the drain pan to check drainage. (Fig. 3-12)

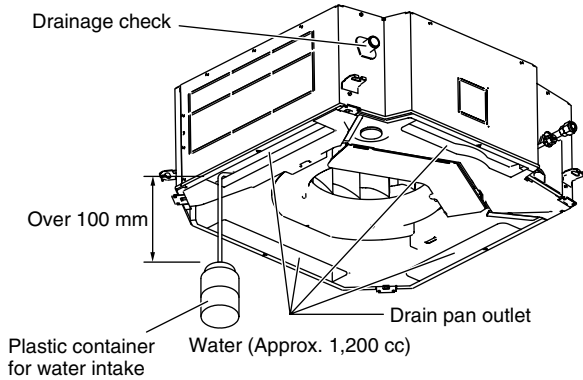

Fig. 3-12

- (3) Short the check pin (CHK) on the indoor control board and operate the drain pump. Check the water flow through the transparent drain pipe and see if there is any leakage.
- (4) When the check of drainage is complete, open the check pin (CHK) and remount the tube cover.



CAUTION
Be careful since the fan will start when you short the pin on the indoor control board.

Wall-Mounted Type (HW Type)

3-6. Removing the Rear Panel from the Unit

- (1) Remove the set screws used to fasten the rear panel to the indoor unit during transportation.
- (2) Press up on the rear panel at the 2 locations shown by the arrows and remove the rear panel (Fig. 3-13).

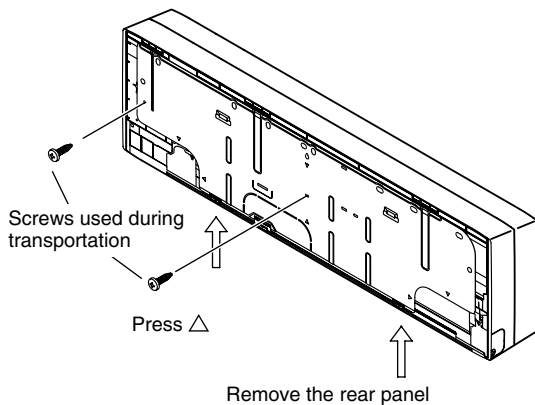

Fig. 3-13

NOTE

Tubing can be extended in 4 directions. Select the direction which will provide the shortest run to the outdoor unit. (Fig. 3-14)

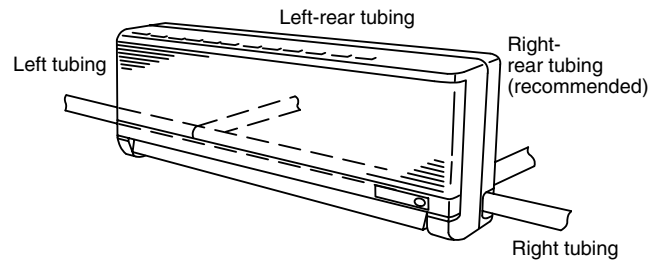

Fig. 3-14

3-7. Selecting and Making a Hole

- (1) Remove the rear panel from the indoor unit and place it on the wall at the location selected. Fix the rear panel and hook the unit onto the wall temporarily. Make sure the unit is horizontal using a carpenter's level or tape measure to measure down from the ceiling.
- (2) Determine which notch of the rear panel should be used. (Fig. 3-15)

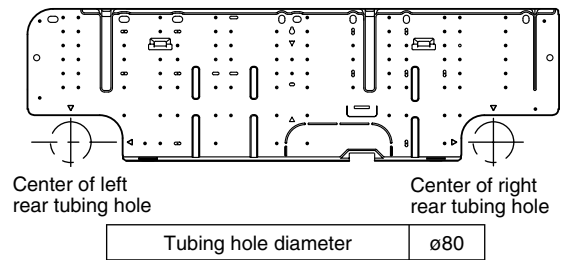

Fig. 3-15

- (3) Before drilling a hole, check that there are no studs or pipes behind the determined location. The above precautions are also applicable if tubing goes through the wall in any other location.
- (4) Using a sabre saw, key hole saw or hole-cutting drill attachment, make a hole (dia. 80 mm) in the wall. (Fig. 3-16)

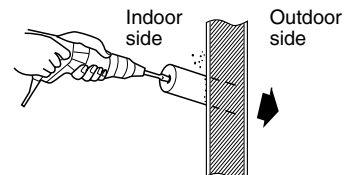

Fig. 3-16

- (5) Measure the thickness of the wall from the inside edge to the outside edge and cut the PVC pipe at a slight angle 6 mm shorter than the thickness of the wall. (Fig. 3-17)

CAUTION

Avoid areas where electrical wiring or conduits are located.

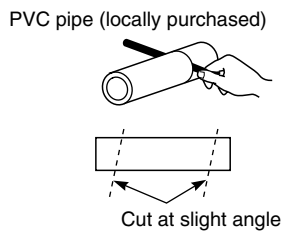

Fig. 3-17

- (6) Place the plastic cover over the end of the pipe (for indoor side only) and insert in the wall. (Fig. 3-18)

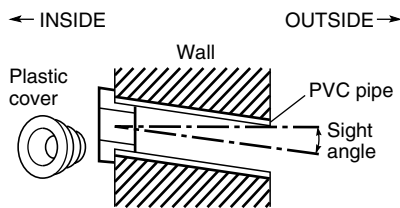

Fig. 3-18

NOTE

The hole should be made at a slight downward gradient to the outside.

3-8. Attaching the Rear Panel onto the Wall

Confirm that the wall is strong enough to support the unit. See either Item a) or b) below depending on the wall type.

a) If the Wall is Wooden

- (1) Attach the rear panel to the wall with the 10 screws provided. (Fig. 3-19)
If you are not able to line up the holes in the rear panel with the beam locations marked on the wall, use Rawl plugs or toggle bolts to go through the holes on the panel or drill 5 mm dia. holes in the panel over the stud locations and then mount the rear panel.

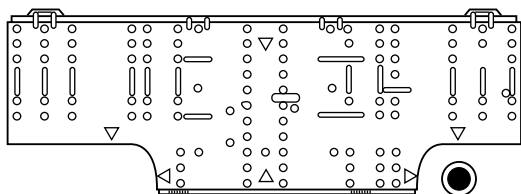

Fig. 3-19

- (2) Check with a tape measure or carpenter's level. This is important so that the unit is correctly installed. (Fig. 3-20)

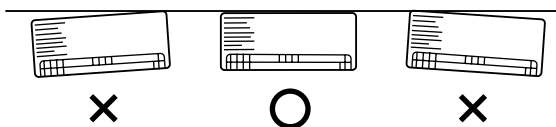

Fig. 3-20

- (3) Make sure the panel is flush against the wall. Any space between the wall and unit will cause noise and vibration.

b) If the Wall is Brick, Concrete or Similar

Drill 4.8 mm dia. holes in the wall. Insert Rawl plugs for appropriate mounting screws. (Fig. 3-21)

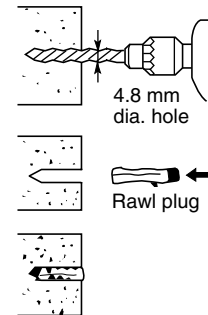

Fig. 3-21

3-9. Removing the Grille to Install the Indoor Unit

In principle, with this model wiring can be completed without removing the grille. However, if it is necessary to change the settings on the PCB, follow the procedure below.

Removing the grille

- (1) Lift up on both sides of the air-intake grille to open. (Fig. 3-22)
(2) Remove the filter. (Fig. 3-22)

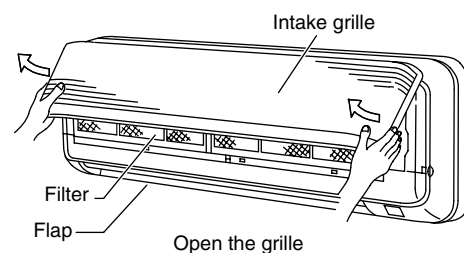

Fig. 3-22

- (3) Adjust the flap so that it is horizontal. (Fig. 3-23)
(4) Open the installation screw covers below the grille (3 locations). (Fig. 3-23)
(5) Remove the screws. (Fig. 3-23)

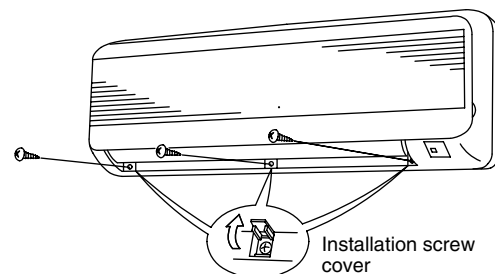

Fig. 3-23

- (6) Remove the grille. (Fig. 3-24)

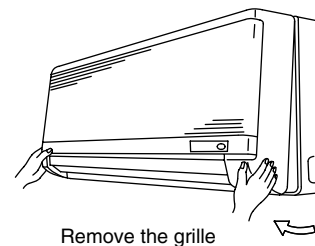

Fig. 3-24

Attaching the grille

- (1) Close the flap.
- (2) Keep the grille installation tabs aligned with the top portion of the grille, and reinstall the lower portion of the grille. Fit the installation tabs into the grooves and press the lower portion of the grille back into its original position.
- (3) Press on the installation tabs to completely close the grille. Check that the grille and frame are fitted tightly together.

3-10. Preparing the Tubing

- (1) Arrangement of tubing by directions
 - a) Right or left tubing
The corner of the right or left frame should be cut with a hacksaw or similar. (Fig. 3-25)

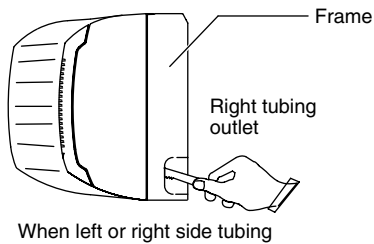

Fig. 3-25

- b) Right-rear or left-rear tubing
In this case, the corners of the frame do not need to be cut.
- (2) Be sure to insulate the part of the drain hose that is run indoors, and the refrigerant tubing. If these are not insulated, condensation may result in dripping and damage to walls and furniture. The flare nuts on the 25-type (only) are large; therefore, use the supplied insulation material.
- (3) To mount the indoor unit on the rear panel.
 1. When attaching the indoor unit, position the indoor unit onto the attachment tabs on the upper part of the rear panel. (Fig. 3-26)

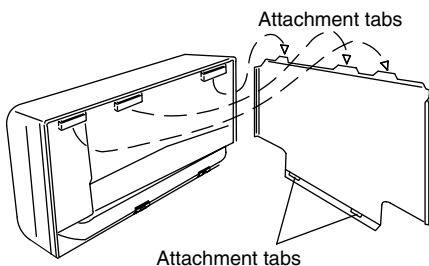

Fig. 3-26

2. Press on the air outlet to hold it in place, and press the lower part of the indoor unit until a "click" sound is heard and the indoor unit is securely fastened to the attachment tabs on the lower side of the rear panel. (Fig. 3-27)

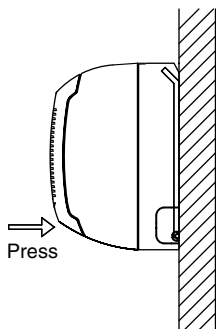

Fig. 3-27

Raising the clamp to lift up the indoor unit will facilitate this work. (Fig. 3-28)

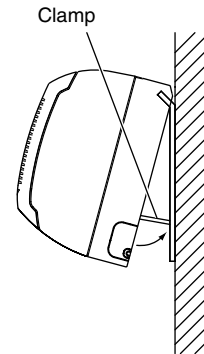

Fig. 3-28

To remove the indoor unit, press up on the 2 locations (△ marks) on the lower part of the unit frame to disconnect from the attachment tabs. Refer to Section 3-6. "Removing the Rear Panel from the Unit" (Fig. 3-13). Then lift up the indoor unit to remove.

3-11. Shaping the Tubing

Right-rear tubing

- (1) Shape the refrigerant tubing so that it can easily go through the hole. (Fig. 3-29)

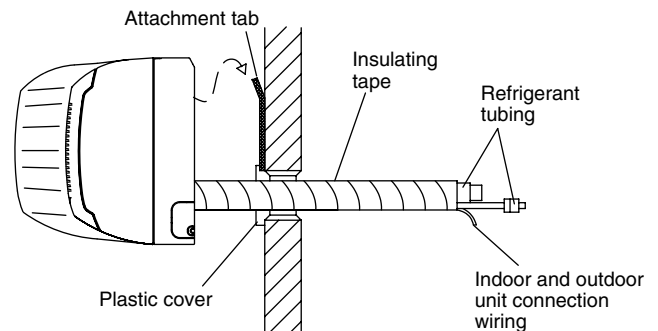

Fig. 3-29

- 2) After performing a leak test, wrap both the refrigerant tubing and drain hose together with insulating tape. The drain hose should be positioned below the refrigerant tubes, and should be given sufficient space so that no strong pressure is applied to it.
 - 3) Push the wiring, refrigerant tubing and drain hose through the hole in the wall. Adjust the indoor unit so it is securely mounted on the rear panel.

Left or left-rear tubing

- (1) Pass the tubing and drain hose into the rear of the indoor unit. Provide sufficient length for the connections to be made (Fig. 3-30). Next, bend the tubing with a pipe bender, and connect them.

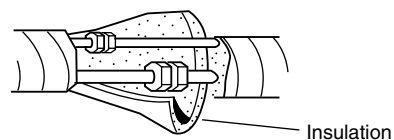

Fig. 3-30

- (2) After performing a leak test, wrap the refrigerant tubing and drain hose together with insulating tape (Fig. 3-31).

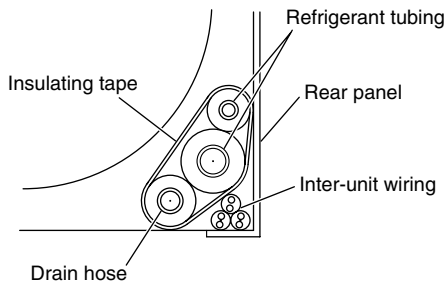

Fig. 3-31

Then fit the tubing into the tubing storage space in the rear of the indoor unit and clamp in place.

- (3) Adjust the indoor unit so that it is securely mounted on the rear panel.

3-12. Installing the Drain Hose

- a) The drain hose should be slanted downward to the outside. (Fig. 3-32)

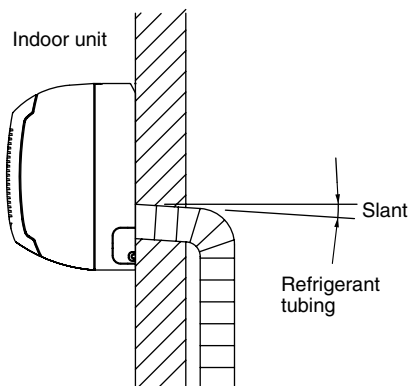

Fig. 3-32

- b) Never allow water traps to be formed in the course of the hose.
- c) If the drain hose will run in the room, insulate* the hose so that chilled condensation will not damage furniture or floors.
- * Foamed polyethylene or its equivalent is recommended.



WARNING

Do not supply power to the unit or operate it until all tubing and wiring to the outdoor unit are completed.

■ Ceiling-Mounted Type (C Type)

3-13. Required Minimum Space for Installation and Service

(1) Dimensions of suspension bolt pitch and unit

Type \ Length	A	B	C
12, 16, 18	855	910	210
25	1125	1180	210
36, 48, 60	1540	1595	210

Unit: mm

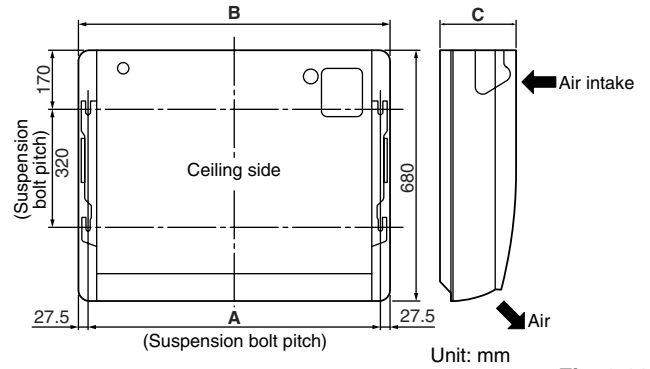

Fig. 3-33

(2) Refrigerant tubing • drain hose position

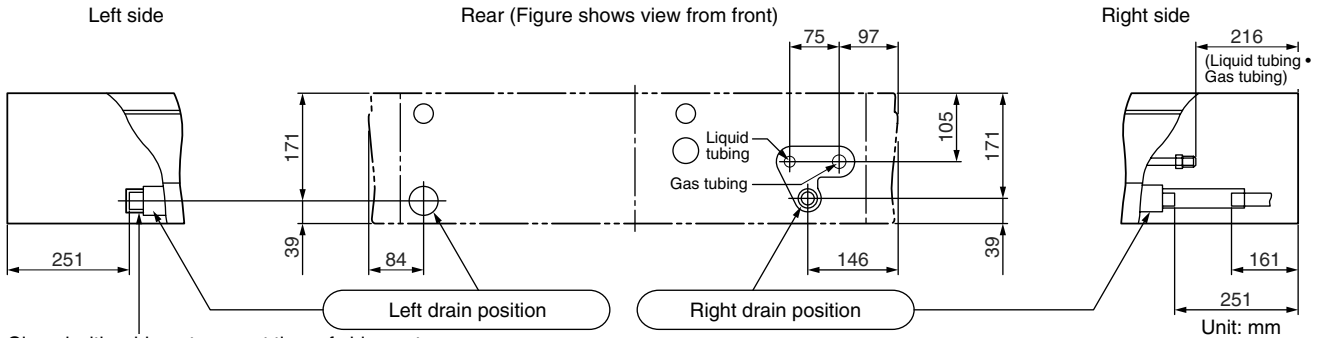
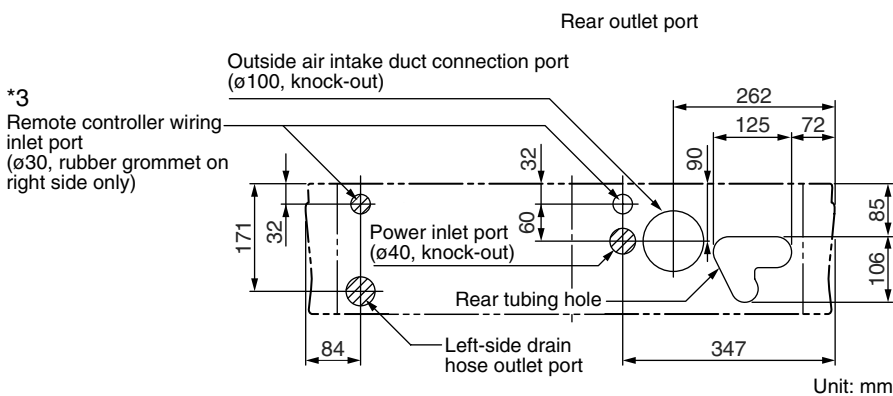
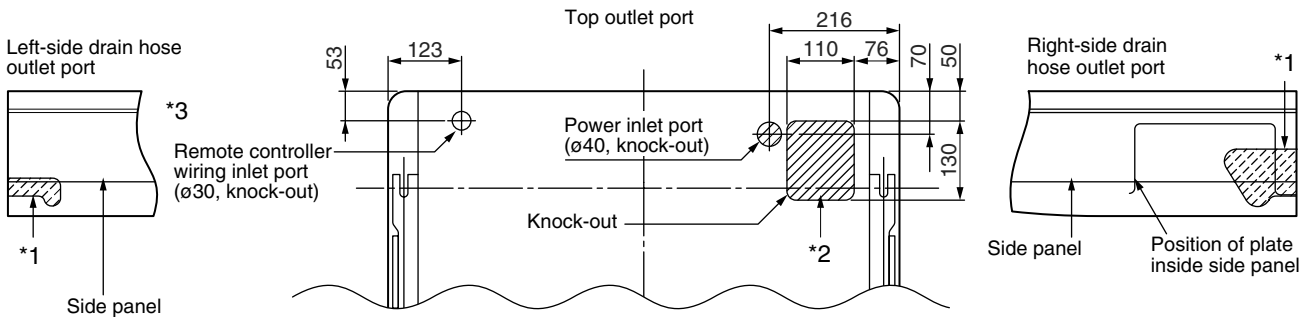

Fig. 3-34

(3) Unit opening position (Refrigerant tubing • drain hose • power inlet port • remote controller wiring inlet port)



*1 Use a compass saw, jig saw or similar tool and cut along the indented portion of the side panel.

*2 If the optional drain up kit is installed, this becomes the upper tubing outlet port. For details, refer to the manual for the optional part.

*3 If the remote controller wiring inlet port is changed to the left side or the left top side, relocate the rubber grommet to the left side. Use aluminum tape or similar material to seal the unused inlet port on the right side.

Fig. 3-35

(4) Wall and ceiling side opening position

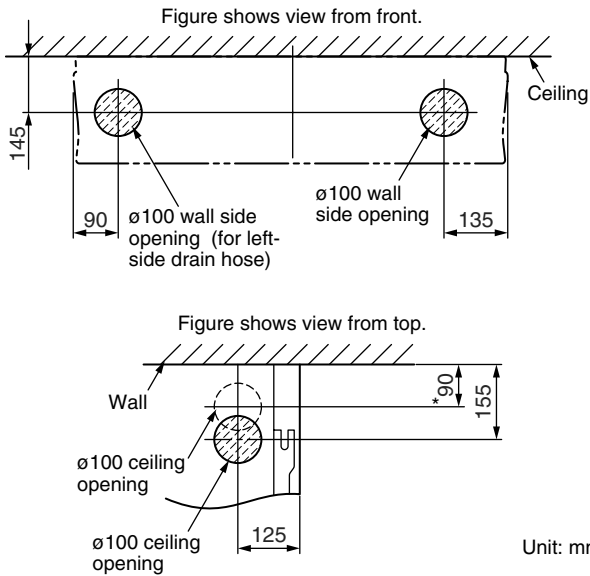

Unit: mm

* If the optional drain up kit is installed, create a $\phi 100$ hole along the dotted line (part marked with * in figure).

Fig. 3-36

3-14. Suspending the Indoor Unit

- (1) Place the full-scale diagram (supplied) on the ceiling at the location where you want to install the indoor unit. Use a pencil to mark the drill holes (Fig. 3-37).

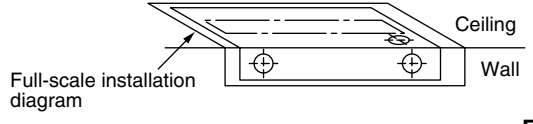

Fig. 3-37

NOTE

Since the diagram is made of paper, it may shrink or stretch slightly because of high temperature or humidity. For this reason, before drilling the holes maintain the correct dimensions between the markings.

- (2) Drill holes at the 4 points indicated on the full-scale diagram.
- (3) Depending on the ceiling type:
 - a) Insert suspension bolts (Fig. 3-38).
or
 - b) Use existing ceiling supports or construct a suitable support (Fig. 3-39).

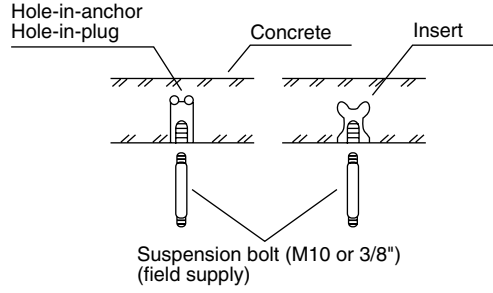

Fig. 3-38

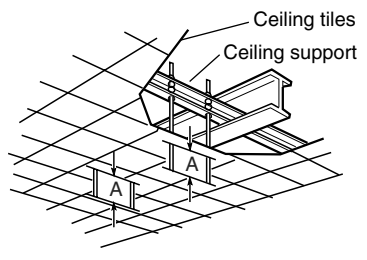

Fig. 3-39

WARNING

It is important that you use extreme care in supporting the indoor unit from the ceiling. Ensure that the ceiling is strong enough to support the weight of the unit. Before hanging the ceiling unit, test the strength of each attached suspension bolt.

- (4) Screw in the suspension bolts, allowing them to protrude from the ceiling (Figs. 3-38 and 3-39). The distance of each exposed bolt must be of equal length within 50 mm. (Fig. 3-40)

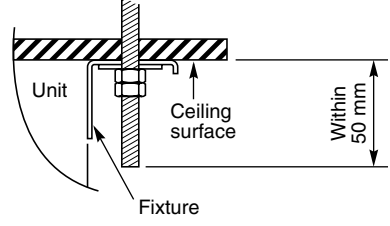

Fig. 3-40

- (5) Before suspending the indoor unit, remove the 2 or 3 screws on the latch of the air-intake grilles, open the grilles, and remove them by pushing the claws of the hinges (Fig. 3-41). Then remove both side panels sliding them along the unit toward the front after removing the 2 attachment screws. (Fig. 3-42)

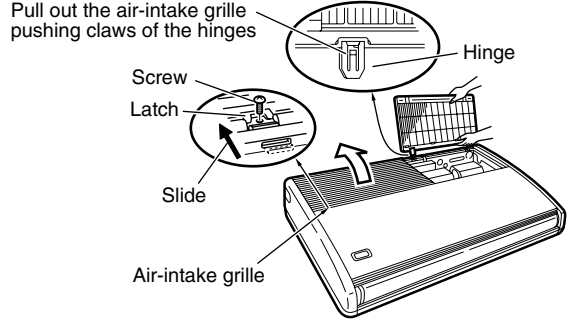

Fig. 3-41

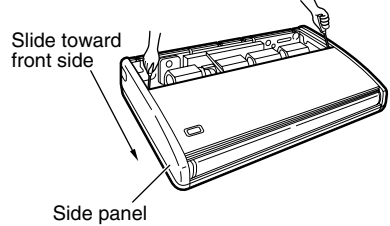

Fig. 3-42

- (6) Carry out the preparation for suspending the indoor unit. The suspension method varies depending on whether there is a suspended ceiling or not. (Figs. 3-43 and 3-44)
- (7) Suspend the indoor unit as follows:
 - a) Mount 1 washer and 2 hexagonal nuts on each suspension bolt (Fig. 3-45).

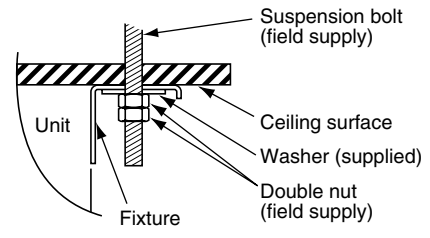

Fig. 3-43

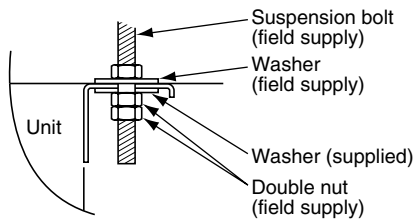

Fig. 3-44

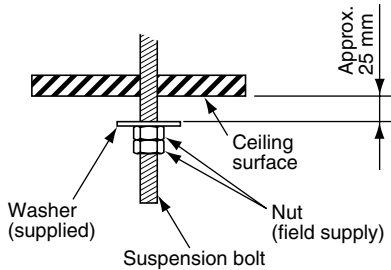

Fig. 3-45

b) Lift the indoor unit, and place it on the washers through the notches, in order to fix it in place. (Fig. 3-46)

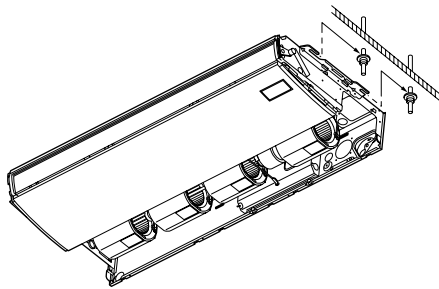

Fig. 3-46

c) Tighten the 2 hexagonal nuts on each suspension bolt to suspend the indoor unit as shown in Fig. 3-47.

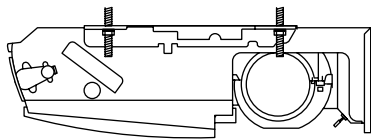

Fig. 3-47

NOTE

The ceiling surface is not always level. Confirm that the indoor unit is evenly suspended. For the installation to be correct, leave a clearance of about 10 mm between the ceiling panel and the ceiling surface and fill the gap with an appropriate insulation or filler material.

- (8) If the tubing and wiring are to go towards the rear of the unit, make holes in the wall. (Fig. 3-48)
- (9) Measure the thickness of the wall from the inside to the outside and cut PVC pipe at a slight angle to fit. Insert the PVC pipe in the wall. (Fig. 3-49)

NOTE

The hole should be made at a slight downward slant to the outside.

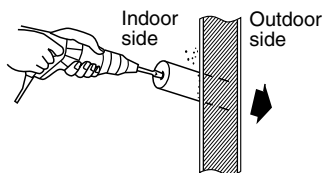

Fig. 3-48

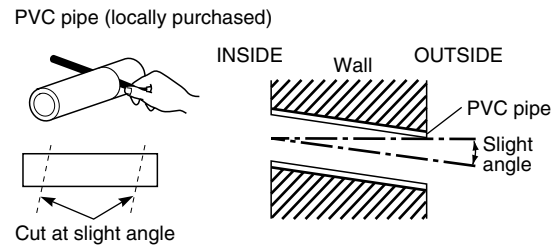

Fig. 3-49

3-15. Duct for Fresh Air

There is a duct connection port (knock-out hole) at the right-rear of the top panel of the indoor unit for drawing in fresh air. If it is necessary to draw in fresh air, remove the cover by opening the hole and connecting the duct to the indoor unit through the connection port. (Fig. 3-50)

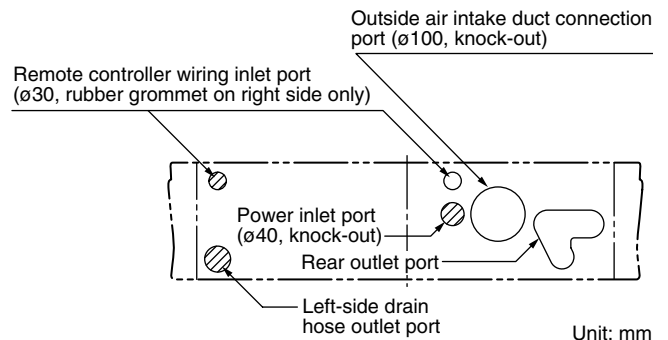

Fig. 3-50

3-16. Shaping the Tubing

- The positions of the refrigerant tubing connections are shown in the figure below. (The tubing can be routed in 3 directions.) (Fig. 3-51)
- * When routing the tubing out through the top or right sides, knock out the appropriate parts in the top panel and cut notches in the side panel (Fig. 3-50).
- * When routing the tubing out through the top, the optional L-shape tubing kit is required.

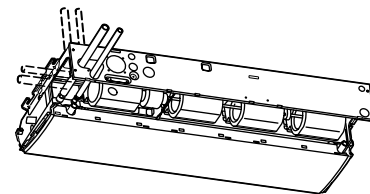

Fig. 3-51

If the tubing is to be routed out together, use a box cutter or similar tool to cut out the part of the rear cover indicated by the marked area (Fig. 3-52), to match the positions of the tubes. Then draw out the tubing.

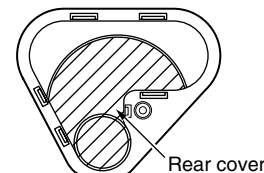

Fig. 3-52

3-17. Installing the Drain Pipe

- Prepare standard PVC pipe for the drain and connect it to the indoor unit drain pipe with the supplied hose clamps to prevent water leaks.

(1) Drain hose connection

- The drain hose is connected below the refrigerant tubing.

(2) Installing the drain hose

- To install the drain hose, first place 1 of the 2 hose bands over the unit drain port and the other hose band over the hard PVC pipe (not supplied). Then connect both ends of the supplied drain hose.
- On the unit drain side, grasp the hose band with pliers and insert the drain hose all the way to the base.

CAUTION

- Attach so that the hose band fastener is on the side of the drain port. (Fig. 3-54)
- Attach the hose bands so that each is approximately 5 to 25 mm from the end of the supplied drain hose.
- If other commercially available hose bands are used, the drain hose may become pinched or wrinkled and there is danger of water leakage. Therefore be sure to use the supplied hose bands. When sliding the hose bands, be careful to avoid scratching the drain hose.
- Do not use adhesive tape when connecting the supplied drain hose to the drain port (either on the main unit or the PVC pipe).
- Wrap the hose with the supplied drain hose insulation and use the 4 twist ties so that the hose is insulated with no gaps.
- Connect the drain pipe so that it slopes downward from the unit to the outside. (Fig. 3-53)

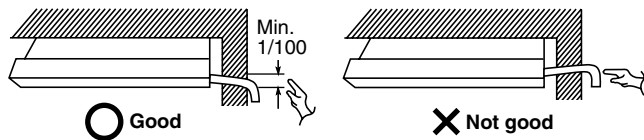
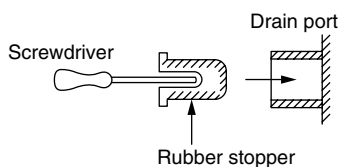

Fig. 3-53

- Never allow water traps to occur in the course of the piping.
- Insulate any piping inside the room to prevent dripping.
- After the drain piping, pour water into the drain pan to check that the water drains smoothly.
- If the drain hose is to be raised, use the optional drain up kit. The drain hose can be raised 60 cm above the top of the main unit. (For details, refer to the manual for the optional part.)

* If the drain hose is routed through the left side, refer to Fig. 3-51, and follow the procedure above to install the hose. Reattach the rubber stopper removed earlier onto the right side. The rubber stopper can be inserted easily by using a screwdriver or similar tool to press the stopper into the drain port on the main unit. Press the stopper into the main unit drain port as far as it will go.



CAUTION

Check local electrical codes and regulations before wiring. Also, check any specified instruction or limitations.

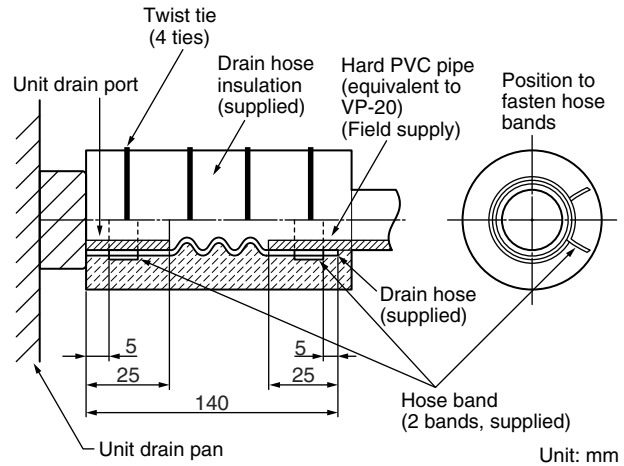

Unit: mm

Fig. 3-54

How to carry out power supply wiring

(1) Wiring connection ports

The power inlet ports are located at the rear and top.

The remote controller wiring inlet ports are located at the rear and top (for use with the wired remote controller). For details, refer to Fig. 3-50. For the method used to insert the wiring, refer to Fig. 3-55.

CAUTION

When removing the fastening bracket from the cover of the electrical component box, use caution to avoid dropping the bracket.

(2) How to carry out wiring

- Open the knock-out hole on the rear or top of the main unit. Attach the supplied rubber grommet and pull the power wiring into the main unit.
- Feed the wiring into the wiring inlet port on the electrical component box. Connect the wiring to the terminal plate and fasten in place with the supplied clamp.
- Perform electrical and grounding work in accordance with the package A/C power specifications, and following local electrical codes and regulations.

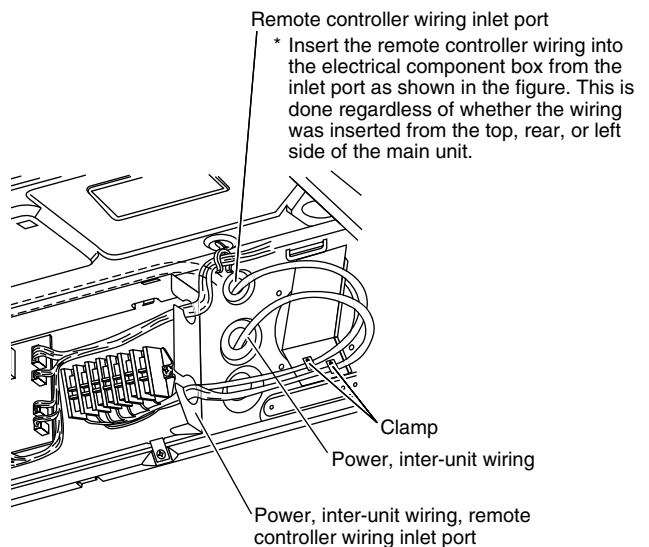

Fig. 3-55

■ Concealed-Duct Type (D Type)

3-18. Required Minimum Space for Installation and Service

- This air conditioner is usually installed above the ceiling so that the indoor unit and ducts are not visible. Only the air intake and air outlet ports are visible from the unit bottom.
- The minimum space for installation and service is shown in Fig. 3-56 and Table 3-3.

Table 3-3 Unit: mm

Type	12, 16, 18	25	36, 48, 60
A (Length)	780	1,080	1,560
Number of duct flanges	2	3	4

- It is recommended that space be provided (450 × 450 mm) for checking and servicing the electrical system.
- The detailed dimensions of the indoor unit is shown in Fig. 3-57 and Table 3-4.

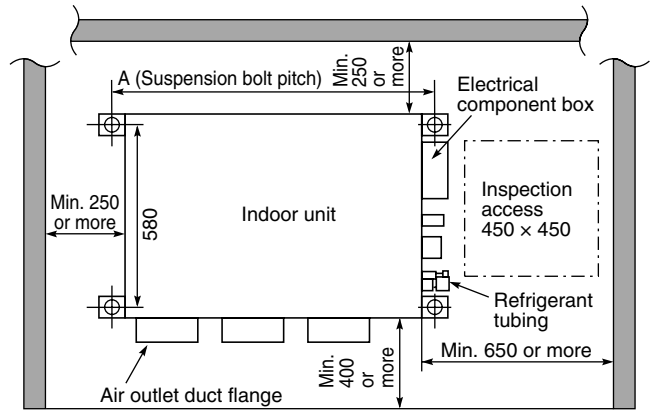

Unit: mm
Fig. 3-56

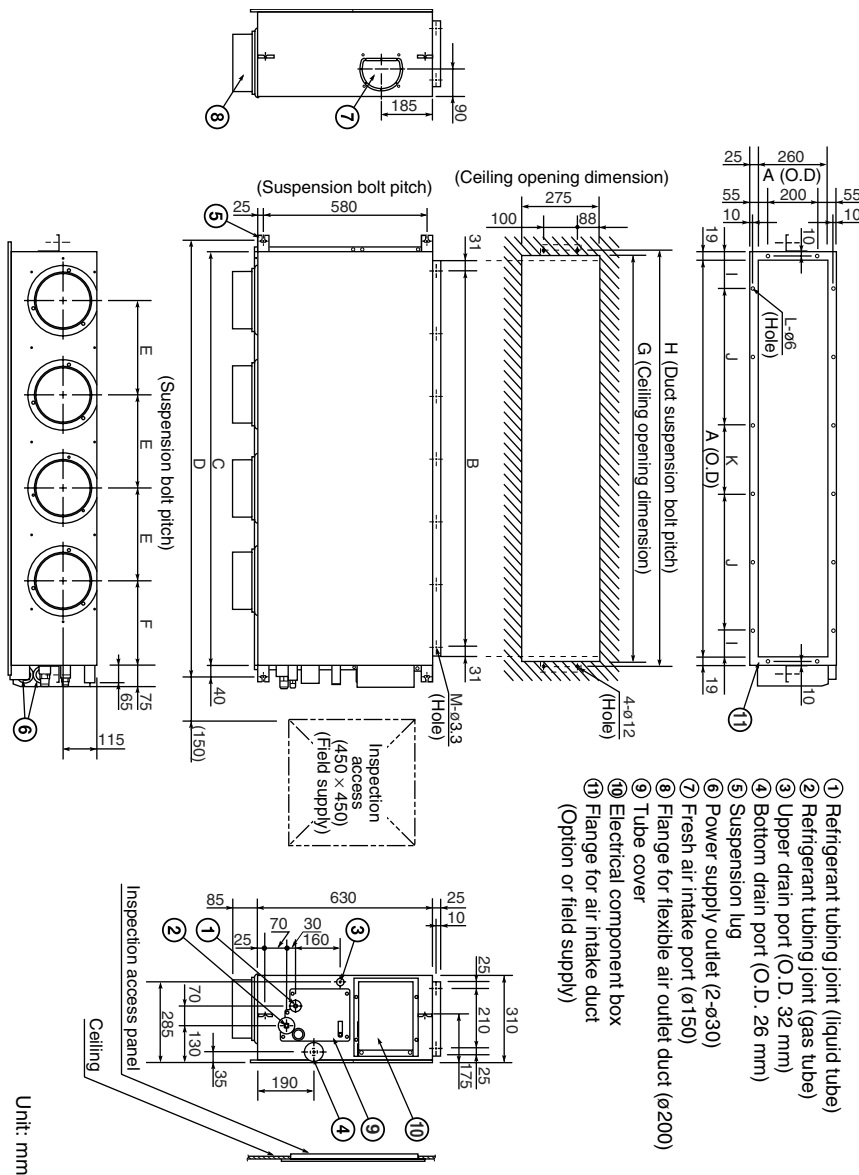

- 1 Refrigerant tubing joint (liquid tube)
- 2 Refrigerant tubing joint (gas tube)
- 3 Upper drain port (O.D. 32 mm)
- 4 Bottom drain port (O.D. 26 mm)
- 5 Suspension lug
- 6 Power supply outlet (2-ø30)
- 7 Fresh air intake port (ø150)
- 8 Flange for flexible air outlet duct (ø200)
- 9 Tube cover
- 10 Electrical component box
- 11 Flange for air intake duct (Option or field supply)

Unit: mm

Fig. 3-57

Table 3-4

Type	Dimension	A	B	C	D	E	F	G	H	I	J	K	No. of holes	
													L	M
12, 16, 18	662	600 (200 × 3)	700	780	290	262	680	715	180	245 (245 × 1)	340	8	12	12
36, 48, 60	1,442	1,380 (230 × 6)	1,480	1,560	335	310	1,460	1,495	130	490 (245 × 2)	240	16	16	18

Unit: mm

3-19. Suspending the Indoor Unit

Depending on the ceiling type:

- Insert suspension bolts (Fig. 3-58) or
- Use existing ceiling supports or construct a suitable support (Fig. 3-59).

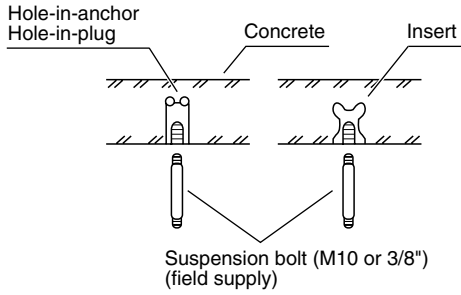

Fig. 3-58

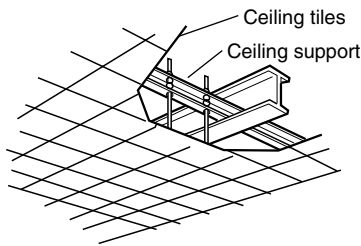

Fig. 3-59

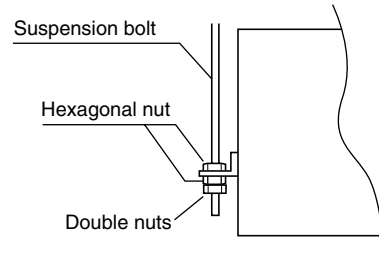

Fig. 3-61

- This shows an example of installation.

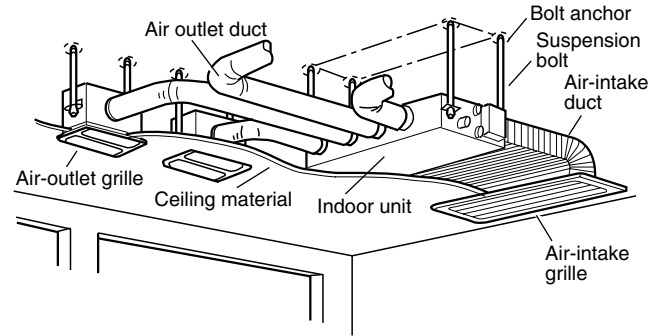

Fig. 3-62

⚠ WARNING

It is important that you use extreme care in supporting the indoor unit inside the ceiling. Ensure that the ceiling is strong enough to support the weight of the unit. Before hanging the unit, test the strength of each attached suspension bolt.

- (1) When placing the unit inside the ceiling, determine the pitch of the suspension bolts referring to the dimensional data as shown in Fig. 3-56 and Table 3-4. Tubing must be laid and connected inside the ceiling when suspending the unit. If the ceiling is already constructed, lay the tubing into position for connection to the unit before placing the unit inside the ceiling.
- (2) Screw in the suspension bolts allowing them to protrude from the ceiling (Fig. 3-58). (Cut the ceiling material, if necessary.)
- (3) Thread the 3 hexagonal nuts and 2 washers (field supply) onto each of the 4 suspension bolts (Figs. 3-60 and 3-61). Use 1 nut and 1 washer for the upper part, and 2 nuts and 1 washer for the lower part, so that the unit will not fall off the suspension lugs.

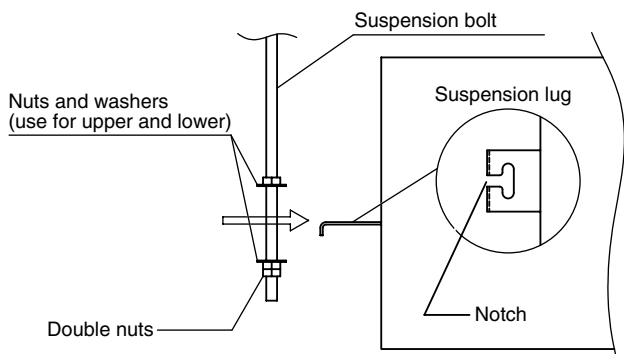

Fig. 3-60

3-20. Installing the Drain Pipe

- Prepare standard hard PVC pipe (O.D. 32 mm) for the drain and use the supplied hose band to prevent water leaks.
The PVC pipe must be purchased separately.
The transparent drain part on the unit allows you to check drainage. (Fig. 3-63)

CAUTION

- Do not use adhesive tape at the drain connection port on the indoor unit.
- Insert the drain pipe until it contacts the socket, and then secure it tightly with the hose band.
- Do not use the supplied drain hose bent at a 90° angle. (The maximum permissible bend is 45°.)
- Tighten the hose clamps so their locking nuts face upward. (Fig. 3-63)

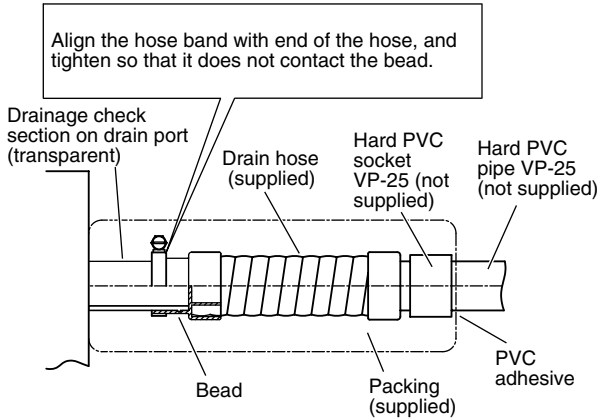

Fig. 3-63

- After connecting the drain pipe securely, wrap the supplied packing and drain pipe insulator around the pipe, then secure it with the supplied vinyl clamps. (Fig. 3-64)

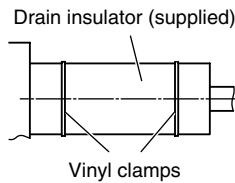

Fig. 3-64

NOTE

Make sure the drain pipe has a downward gradient (1/100 or more) and that there are no water traps.

CAUTION

- Do not install an air bleeder as this may cause water to spray from the drain pipe outlet. (Fig. 3-65-1)

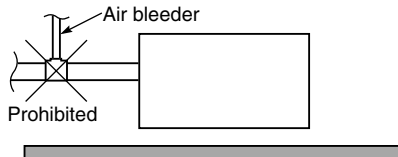

Fig. 3-65-1

- If it is necessary to increase the height of the drain pipe, the section directly after the connection port can be raised a maximum of 50 cm. Do not raise it any higher than 50 cm, as this could result in water leaks. (Fig. 3-65-2)

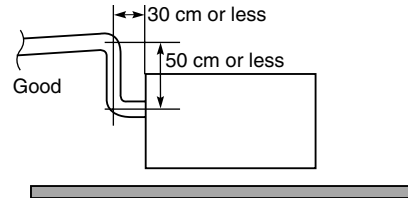

Fig. 3-65-2

- Do not install the pipe with an upward gradient from the connection port. This will cause the drain water to flow backward and leak when the unit is not operating. (Fig. 3-65-3)

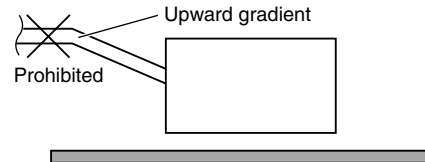

Fig. 3-65-3

- Do not apply force to the piping on the unit side when connecting the drain pipe. The pipe should not be allowed to hang unsupported from its connection to the unit. Fasten the pipe to a wall, frame, or other support as close to the unit as possible. (Fig. 3-65-4)

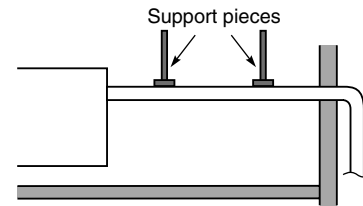

Fig. 3-65-4

NOTE

Refer to the Section "■ SUPPLEMENT ON DRAIN PIPING".

3-21. Checking the Drainage

After wiring and drain piping are completed, use the following procedure to check that the water will drain smoothly. For this, prepare a bucket and wiping cloth to catch and wipe up spilled water.

- (1) Connect power to the power terminal board (R, S terminals) inside the electrical component box.
- (2) Remove the tube cover and slowly pour about 1,200 cc of water through the opening into the drain pan to check drainage.
- (3) Short-circuit the check pin (CHK) on the indoor control circuit board and operate the drain pump. Check the water flow through the transparent drain port and see if there is any leakage.



Be careful since the fan will start when you short the pin on the indoor control board.

- (4) When the drainage check is complete, open the check pin (CHK) and remount the insulator and drain cap onto the drain inspection port.

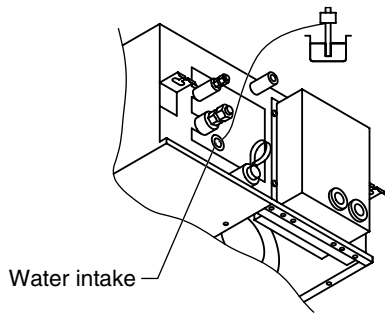

Fig. 3-66

3-22. Increasing the Fan Speed

If external static pressure is too great (due to long extension of ducts, for example), the airflow volume may drop too low at each air outlet. This problem may be solved by increasing the fan speed using the following procedure:

- (1) Remove 4 screws on the electrical component box and remove the cover plate.
- (2) Disconnect the fan motor sockets in the box.
- (3) Take out the booster cable (sockets at both ends) clamped in the box.
- (4) Securely connect the booster cable sockets between the disconnected fan motor sockets in step 2 (Fig. 3-67).

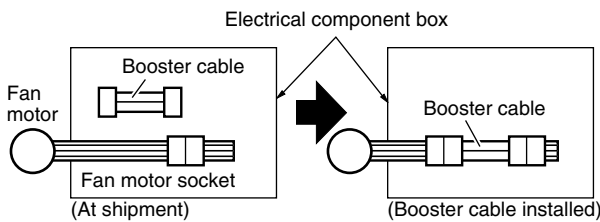

Fig. 3-67

- (5) Place the cable neatly in the box and reinstall the cover plate.

Indoor Fan Performance

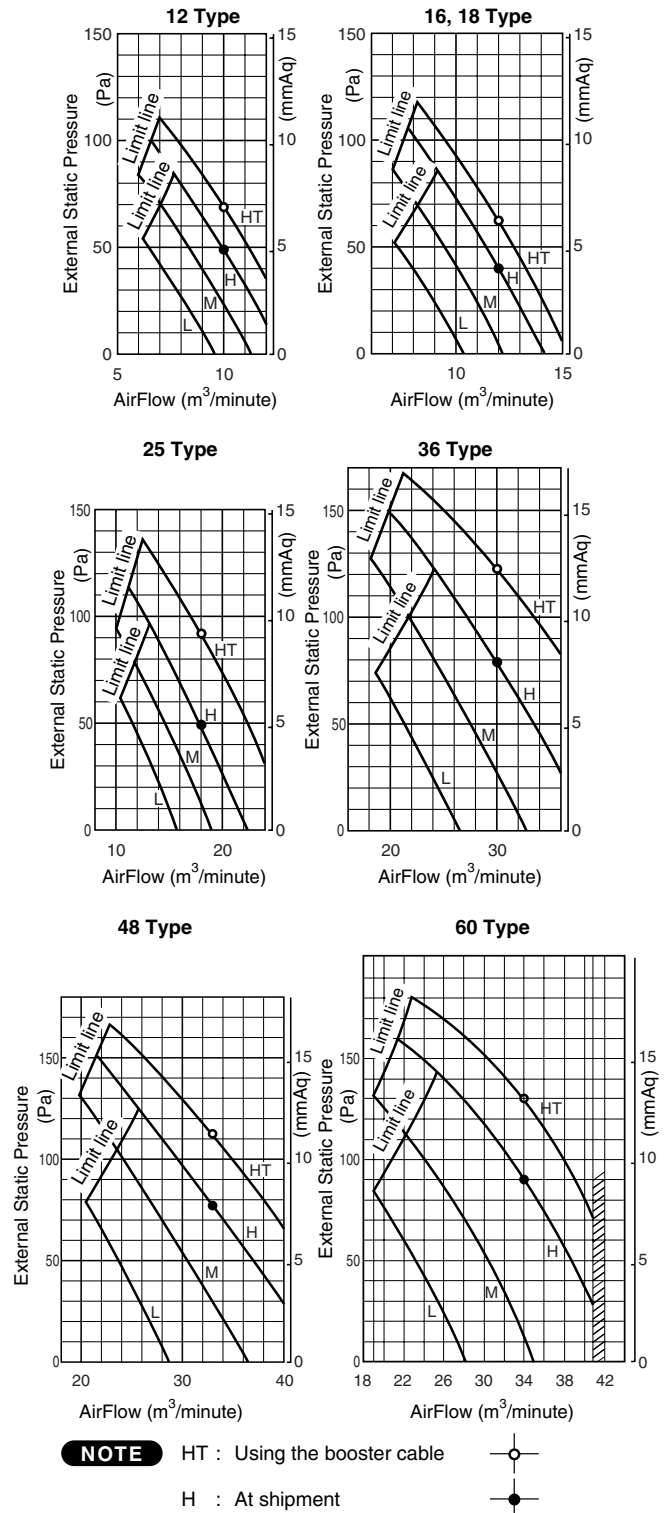

Fig. 3-68

■ How to read the diagram

The vertical axis is the external static pressure (Pa) while the horizontal axis represents the airflow ($m^3/minute$). The characteristic curves for “HT”, “H”, “M” and “L” fan speed control are shown. The nameplate values are shown based on the “H” airflow. For the 25 type, the airflow is $18 m^3/minute$, while the external static pressure is $49 Pa$ at “H” position. If external static pressure is too great (due to long extension of ducts, for example), the airflow volume may drop too low at each air outlet. This problem may be solved by increasing the fan speed as explained above.

3-23. When Installing the Indoor Unit

Confirm that the indoor unit should be installed in a horizontal position. Use the level gauge or vinyl tube and check every four corner of the unit is in horizontal.

If the air outlet duct flange is positioned with downward gradient, there is in danger of water splash or drainage.

Also, dust may sometimes be contaminated inside the drain pan caused by the residual drain water.

Install the air outlet duct flange side in horizontal or upward and within the range of 10mm in the upward direction.

Never install it with a downward gradient against horizontal.

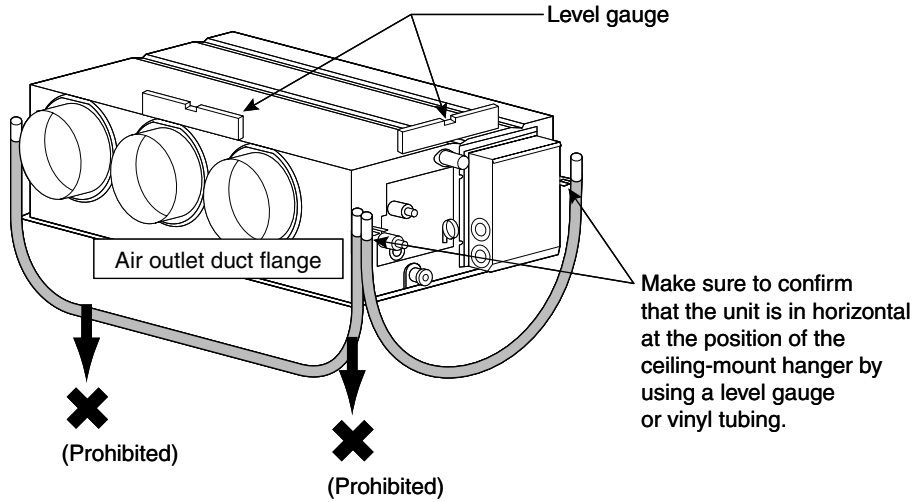

Fig. 3-69

3-24. Required Minimum Space for Installation and Service

If the ceiling tiles cannot be removed, provide the opening holes on the lower side of the indoor unit for removing the unit in order to maintain and clean the drain pan and heat exchanger or provide a minimum of 300mm or more space.

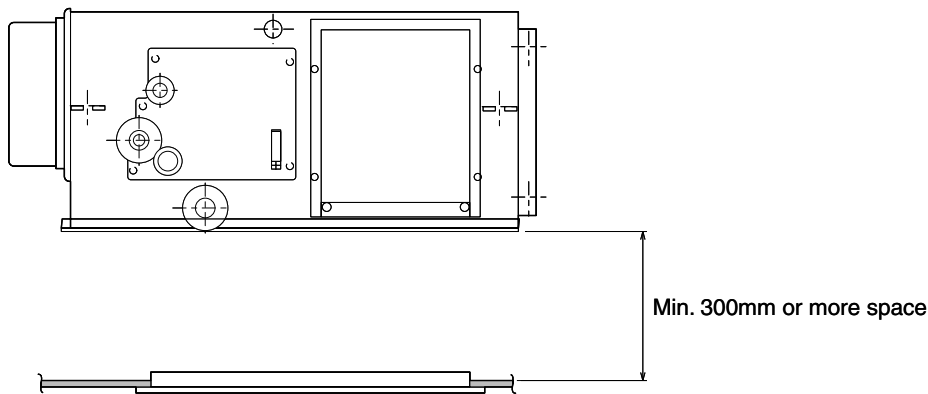
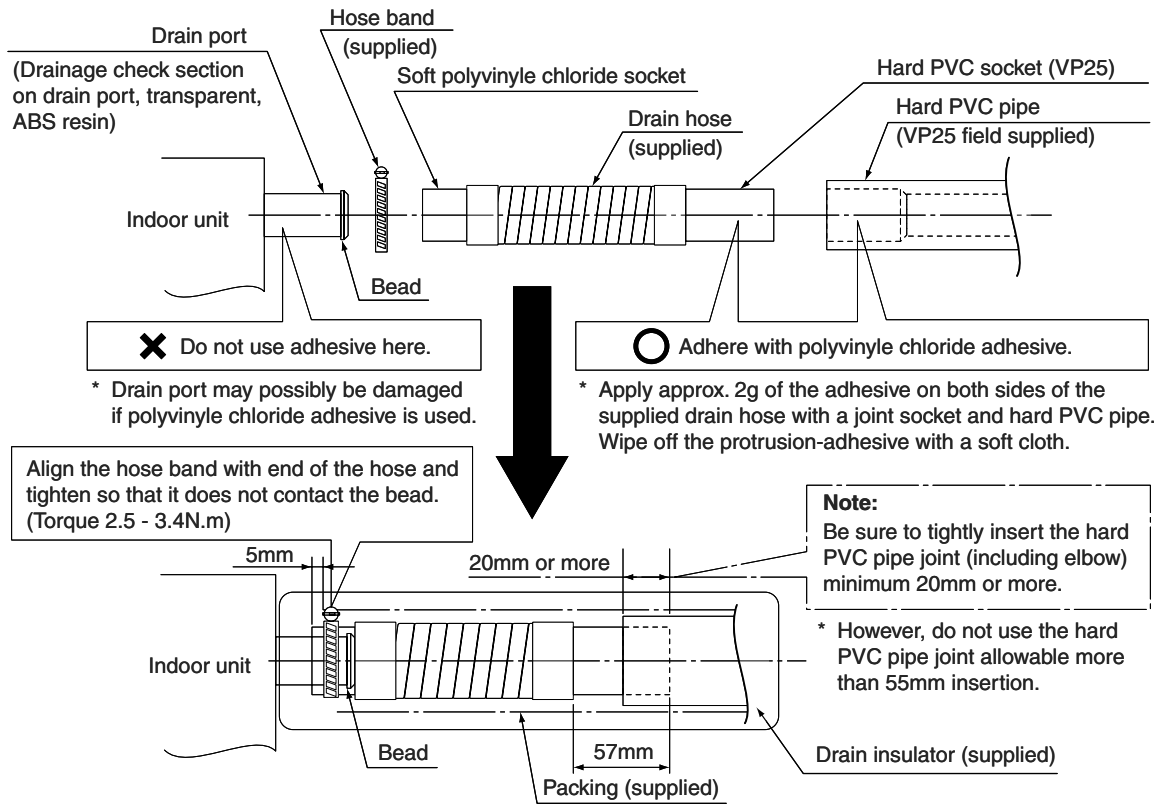

Fig. 3-70

■ SUPPLEMENT ON DRAIN PIPING

1. Drain hose installation



* After checking the drainage, wrap the supplied packing and drain pipe insulator around the pipe.

NOTE

There is possibility to cause water leakage unless the above steps are carried out.

2. Checkpoint after installation

After installation of indoor and outdoor units, panels and electrical wiring, check the following items.

Checkpoint	Symptom	Check	Remark
1 Are indoor and outdoor units correctly installed?	Fall, vibration, noise		
2 Is gas leakage tested?	No cooling, no heating		
3 Is insulation completed? (Refrigerant piping and drain piping)	water leakage		
4 Is drain water running smoothly?	water leakage		
5 Does the power voltage meet the nameplate?	Inoperative, burnout		
6 Is there miswiring or incorrect connection?	Inoperative, burnout		
7 Is the ground construction completed?	Ground leakage		
8 Is the wire gauge followed by the recommended specifications?	Inoperative, burnout		
9 Are the air intake and air outlet of the indoor and outdoor units sealed by any obstacles?	No cooling, no heating		

5. ELECTRICAL WIRING

5-1. General Precautions on Wiring

- (1) Before wiring, confirm the rated voltage of the unit as shown on its nameplate, then carry out the wiring closely following the wiring diagram.
- (2) Provide a power outlet to be used exclusively for each unit and a circuit breaker for overcurrent protection should be provided in the exclusive line.
- (3) To prevent possible hazards from insulation failure, the unit must be grounded.
- (4) Each wiring connection must be done in accordance with the wiring system diagram. Wrong wiring may cause the unit to misoperate or become damaged.
- (5) Do not allow wiring to touch the refrigerant tubing, compressor, or any moving parts of the fan.
- (6) Unauthorized changes in the internal wiring can be very dangerous. The manufacturer will accept no responsibility for any damage or misoperation that occurs as a result of such unauthorized changes.
- (7) Regulations on wire diameters differ from locality to locality. For field wiring rules, please refer to your LOCAL ELECTRICAL CODES before beginning.
You must ensure that installation complies with all relevant rules and regulations.
- (8) To prevent malfunction of the air conditioner caused by electrical noise, care must be taken when wiring as follows:
 - The remote control wiring and the inter-unit control wiring should be wired apart from the inter-unit power wiring.
 - Use shielded wires for inter-unit control wiring between units and ground the shield on both sides.
- (9) If the power supply cord of this appliance is damaged, it must be replaced by a repair shop designated by the manufacturer, because special-purpose tools are required.

5-2. Recommended Wire Length and Wire Diameter for Power Supply System

Outdoor unit (Single-phase)

	(A) Power supply		Time delay fuse or circuit capacity
	Wire size	Max. length	
OU-PSINV-25HR	4 mm ²	24 m	25 A
OU-PSINV-36HR	4 mm ²	22 m	25 A
OU-PSINV-48HR	6 mm ²	30 m	35 A
OU-PSINV-60H	6 mm ²	19 m	35 A

Indoor unit

Type	(B) Power supply	Time delay fuse or circuit capacity
	2.5 mm ²	
HW	Max. 150 m	10 A
4WK, C, D	Max. 130 m	10 A

Control wiring

(C) Inter-unit (between outdoor and indoor units) control wiring	(D) Remote control wiring	(E) Control wiring for group control
0.75 mm ² (AWG #18) Use shielded wiring*	0.75 mm ² (AWG #18) Use shielded wiring	0.75 mm ² (AWG #18) Use shielded wiring
Max. 1,000 m	Max. 500 m	Max. 200 m (Total)

NOTE

* With ring-type wire terminal.

5-3. Wiring System Diagrams

(for single-phase outdoor unit)

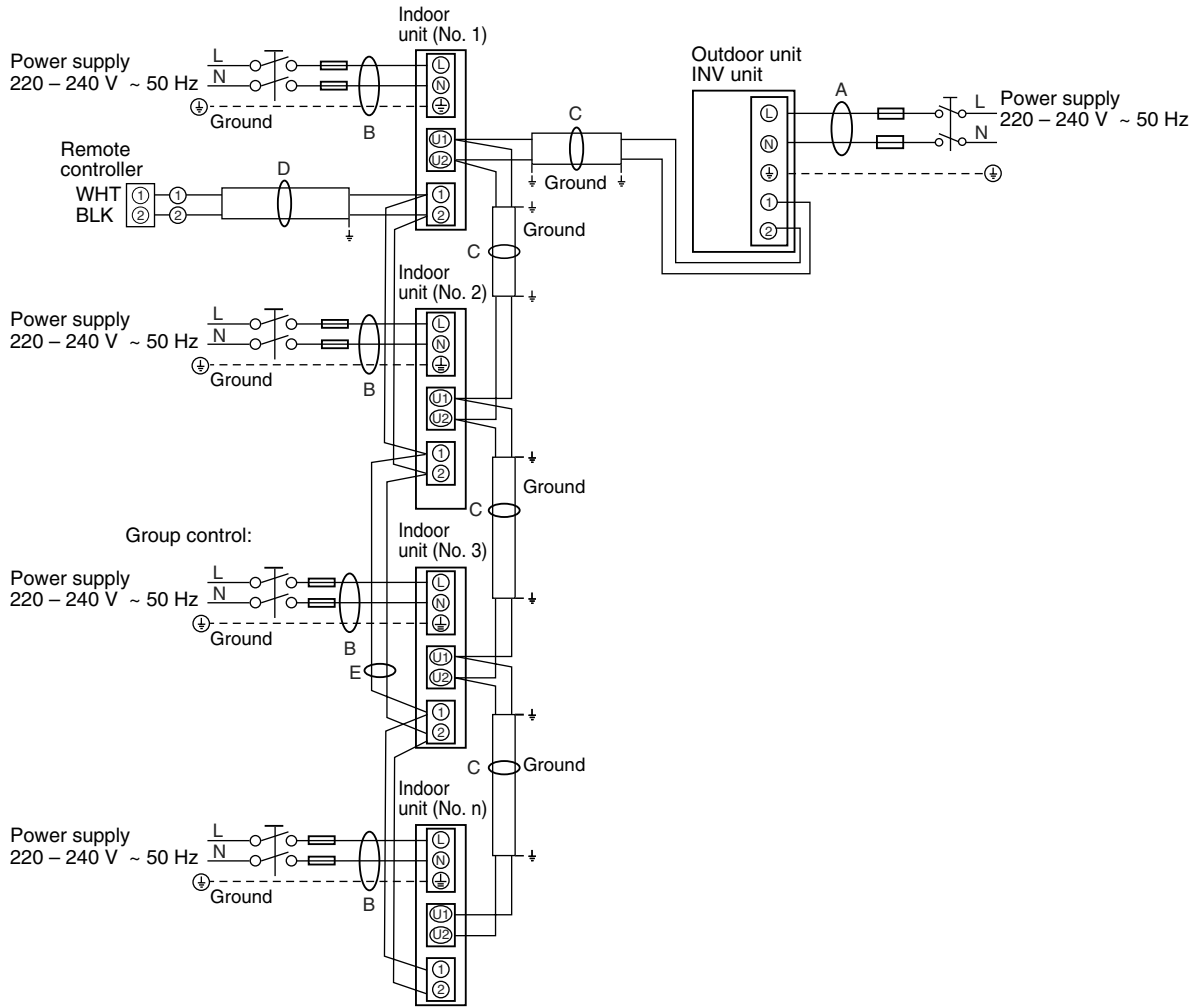

Fig. 5-1

NOTE

- (1) Refer to Section 5-2. "Recommended Wire Length and Wire Diameter for Power Supply System" for the explanation of "A", "B", "C", "D" and "E" in the above diagrams.
- (2) The basic connection diagram of the indoor unit shows the 7P terminal board, so the terminal boards in your equipment may differ from the diagram.
- (3) Refrigerant Circuit (R.C.) address should be set before turning the power on.
- (4) Regarding R.C. address setting, refer to the instruction manual supplied with the remote controller unit (optional). Auto address setting can be executed by remote controller automatically. Refer to the instruction manual supplied with the remote controller unit (optional).

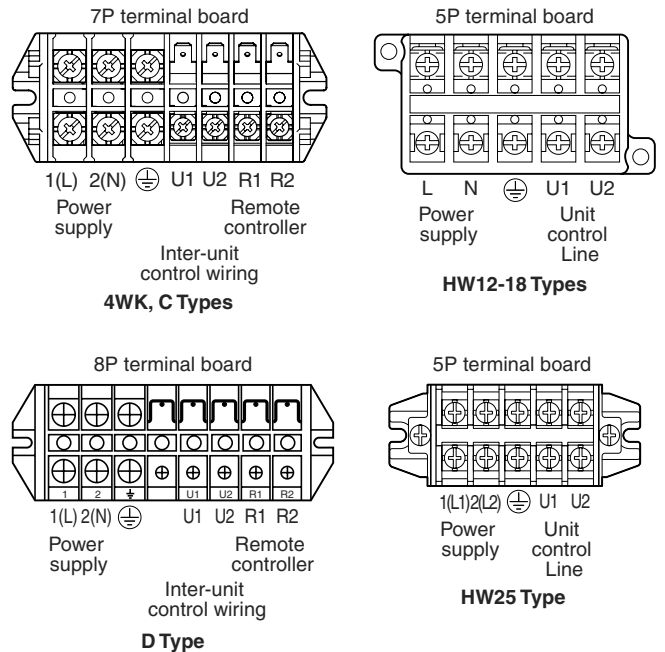

Fig. 5-2

CAUTION

- When linking the outdoor units in a network (S-net link system), disconnect the terminal extended from the short plug (CN003, 2P Black, location: right bottom on the outdoor main control PCB) from all outdoor units except any one of the outdoor units.
(When shipping: In shorted condition.)
Otherwise the communication of S-net link system is not performed. For a system without link (no wiring connection between outdoor units), do not remove the short plug.
- Do not install the inter-unit control wiring in a way that forms a loop. (Fig. 5-3)

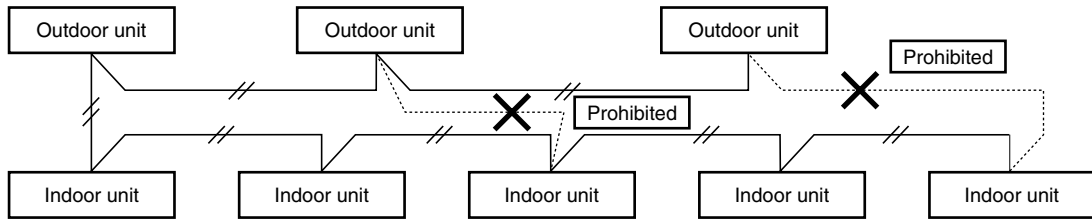

Fig. 5-3

- Do not install inter-unit control wiring such as star branch wiring. Star branch wiring causes mis-address setting. (Fig. 5-4)

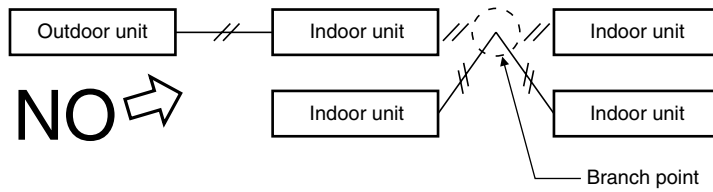

Fig. 5-4

- If branching the inter-unit control wiring, the number of branch points should be 16 or fewer.
(Branches that are less than 1 m are not included in the total branch number.) (Fig. 5-5)

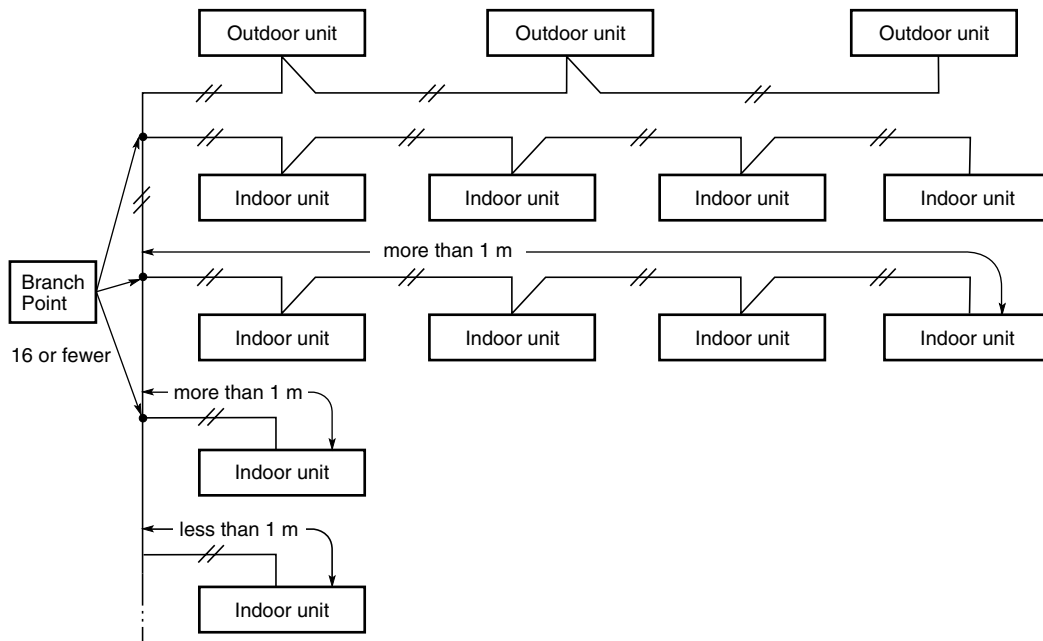

Fig. 5-5

- (5) Use shielded wires for inter-unit control wiring (c) and ground the shield on one side, otherwise misoperation from noise may occur. (Fig. 5-6)
Connect wiring as shown in Section “5-3. Wiring System Diagrams”.

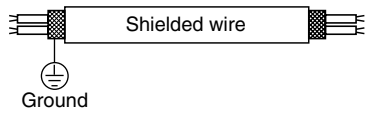

Fig. 5-6

WARNING

Loose wiring may cause the terminal to overheat or result in unit malfunction. A fire hazard may also occur. Therefore, ensure that all wiring is tightly connected.

When connecting each power wire to the terminal, follow the instructions on “How to connect wiring to the terminal” and fasten the wire securely with the terminal screw.

How to connect wiring to the terminal

For stranded wires

- Cut the wire end with cutting pliers, then strip the insulation to expose the stranded wire about 10 mm and tightly twist the wire ends. (Fig. 5-7)

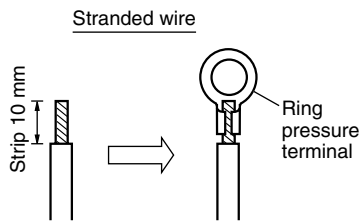

Fig. 5-7

- Using a Phillips head screwdriver, remove the terminal screw(s) on the terminal plate.
- Using a ring connector fastener or pliers, securely clamp each stripped wire end with a ring pressure terminal.
- Put the removed terminal screw through the ring pressure terminal and then replace and tighten the terminal screw using a screwdriver. (Fig. 5-8)

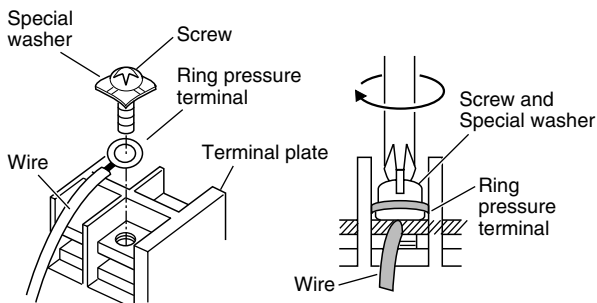

Fig. 5-8

6. HOW TO INSTALL THE TIMER REMOTE CONTROLLER (OPTIONAL PART)

NOTE

Refer to the Instruction Manual attached to the optional Timer Remote Control Unit.

7. HOW TO PROCESS TUBING

The liquid tubing side is connected by a flare nut, and the gas tubing side is connected by brazing.

7-1. Connecting the Refrigerant Tubing

Use of the Flaring Method

Many of conventional split system air conditioners employ the flaring method to connect refrigerant tubes that run between indoor and outdoor units. In this method, the copper tubes are flared at each end and connected with flare nuts.

Flaring Procedure with a Flare Tool

- Cut the copper tube to the required length with a tube cutter. It is recommended to cut approx. 30 – 50 cm longer than the tubing length you estimate.
- Remove burrs at each end of the copper tubing with a tube reamer or file. This process is important and should be done carefully to make a good flare. Be sure to keep any contaminants (moisture, dirt, metal filings, etc.) from entering the tubing. (Figs. 7-1 and 7-2)

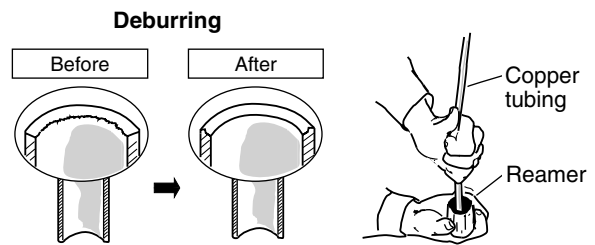

Fig. 7-1

Fig. 7-2

NOTE

When reaming, hold the tube end downward and be sure that no copper scraps fall into the tube. (Fig. 7-2)

- Remove the flare nut from the unit and be sure to mount it on the copper tube.
- Make a flare at the end of the copper tube with a flare tool. (Fig. 7-3)

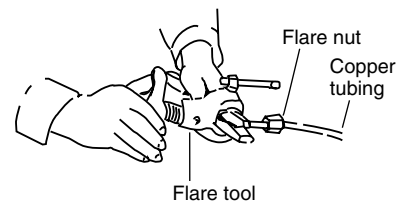

Fig. 7-3

NOTE

A good flare should have the following characteristics:

- inside surface is glossy and smooth
- edge is smooth
- tapered sides are of uniform length

Flare size: A (mm)

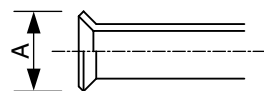

Copper tubing (Outer dia.)	A _{-0.4} ⁰
ø6.35	9.1
ø9.52	13.2
ø12.7	16.6
ø15.88	19.7

Caution Before Connecting Tubes Tightly

- (1) Apply a sealing cap or water-proof tape to prevent dust or water from entering the tubes before they are used.
- (2) Be sure to apply refrigerant lubricant to the matching surfaces of the flare and union before connecting them together. This is effective for reducing gas leaks. (Fig. 7-4)

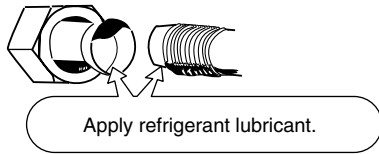

Fig. 7-4

- (3) For proper connection, align the union tube and flare tube straight with each other, then screw on the flare nut lightly at first to obtain a smooth match. (Fig. 7-5)

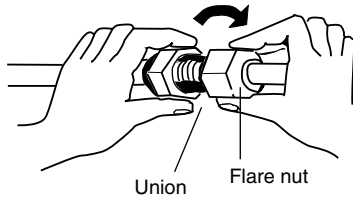

Fig. 7-5

- Adjust the shape of the liquid tube using a tube bender at the installation site and connect it to the liquid tubing side valve using a flare.

Cautions During Brazing

- **Replace air inside the tube with nitrogen gas to prevent copper oxide film from forming during the brazing process. (Oxygen, carbon dioxide and Freon are not acceptable.)**
- **Do not allow the tubing to get too hot during brazing. The nitrogen gas inside the tubing may overheat, causing refrigerant system valves to become damaged. Therefore allow the tubing to cool when brazing.**
- **Use a reducing valve for the nitrogen cylinder.**
- **Do not use agents intended to prevent the formation of oxide film. These agents adversely affect the refrigerant and refrigerant oil, and may cause damage or malfunctions.**

7-2. Connecting Tubing Between Indoor and Outdoor Units

- (1) Tightly connect the indoor-side refrigerant tubing extended from the wall with the outdoor-side tubing.
 - (2) To fasten the flare nuts, apply specified torque.
- When removing the flare nuts from the tubing connections, or when tightening them after connecting the tubing, be sure to use 2 adjustable wrenches or spanners. (Fig. 7-6) If the flare nuts are over-tightened, the flare may be damaged, which could result in refrigerant leakage and cause injury or asphyxiation to room occupants.

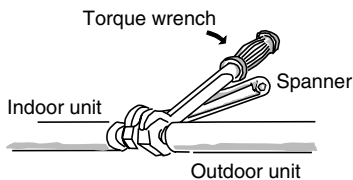

Fig. 7-6

- When removing or tightening the gas tube flare nut, use 2 adjustable wrenches together: one at the gas tube flare nut, and the other at part A. (Fig. 7-7)

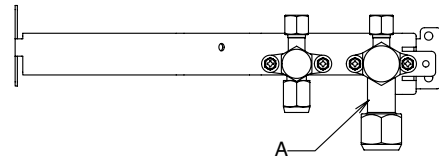

Fig. 7-7

- For the flare nuts at tubing connections, be sure to use the flare nuts that were supplied with the unit, or else flare nuts for R410A (type 2). The refrigerant tubing that is used must be of the correct wall thickness as shown in the table below.

Tube diameter	Tightening torque (approximate)	Tube thickness
ø6.35 (1/4")	14 – 18 N · m (140 – 180 kgf · cm)	0.8 mm
ø9.52 (3/8")	34 – 42 N · m (340 – 420 kgf · cm)	0.8 mm
ø12.7 (1/2")	49 – 61 N · m (490 – 610 kgf · cm)	0.8 mm
ø15.88 (5/8")	68 – 82 N · m (680 – 820 kgf · cm)	1.0 mm

Because the pressure is approximately 1.6 times higher than conventional refrigerant pressure, the use of ordinary flare nuts (type 1) or thin-walled tubes may result in tube rupture, injury, or asphyxiation caused by refrigerant leakage.

- In order to prevent damage to the flare caused by over-tightening of the flare nuts, use the table above as a guide when tightening.
- When tightening the flare nut on the liquid tube, use an adjustable wrench with a nominal handle length of 200 mm.
- Do not use a spanner to tighten the valve stem caps. Doing so may damage the valves.
- Depending on the installation conditions, applying excessive torque may cause the nuts to crack.

Precautions for Packed Valve Operation

- If the packed valve is left for a long time with the valve stem cap removed, refrigerant will leak from the valve. Therefore, do not leave the valve stem cap removed. (Fig.7-8)
- Use a torque wrench to securely tighten the valve stem cap.

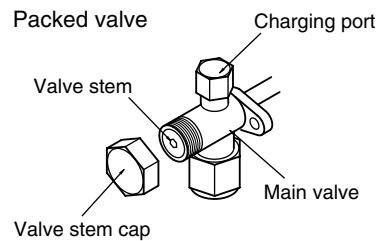

Fig. 7-8

- Valve stem cap tightening torque:

Charging port	8 – 10 N · m (80 – 100 kgf · cm)
ø9.52 (Liquid side)	19 – 21 N · m (190 – 210 kgf · cm)
ø15.88 (Gas side)	28 – 32 N · m (280 – 320 kgf · cm)

7-3. Insulating the Refrigerant Tubing

Tubing Insulation

● Thermal insulation must be applied to all units tubing, including distribution joint (purchased separately). (Fig. 7-9)

* For gas tubing, the insulation material must be heat resistant to 120°C or above. For other tubing, it must be heat resistant to 80°C or above.

Insulation material thickness must be 10 mm or greater.

If the conditions inside the ceiling exceed DB 30°C and RH 70%, increase the thickness of the gas tubing insulation material by 1 step.

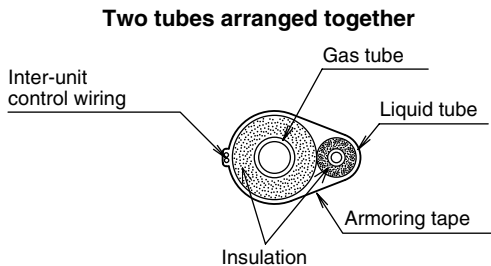

Fig. 7-9

CAUTION

If the exterior of the outdoor unit valves has been finished with a square duct covering, make sure you allow sufficient space to access the valves and to allow the panels to be attached and removed.

Taping the flare nuts

Wind the white insulation tape around the flare nuts at the gas tube connections. Then cover up the tubing connections with the flare insulator, and fill the gap at the union with the supplied black insulation tape. Finally, fasten the insulator at both ends with the supplied vinyl clamps. (Fig. 7-10)

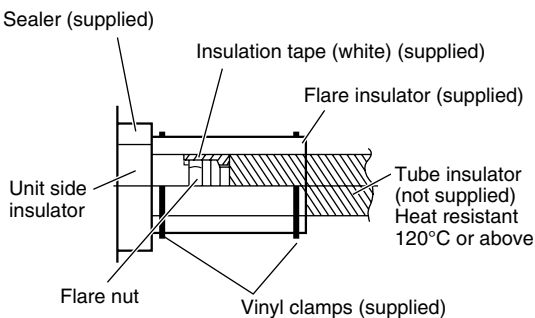

Fig. 7-10

Insulation material

The material used for insulation must have good insulation characteristics, be easy to use, be age resistant, and must not easily absorb moisture. (Fig. 7-11)

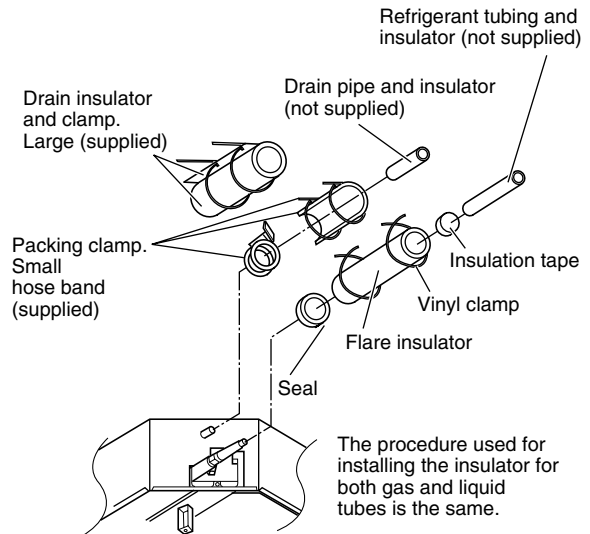

Fig. 7-11

CAUTION

After a tube has been insulated, never try to bend it into a narrow curve because it can cause the tube to break or crack.

Never grasp the drain or refrigerant connecting outlets when moving the unit.

7-4. Taping the Tubes

- (1) At this time, the refrigerant tubes (and electrical wiring if local codes permit) should be taped together with armoring tape in 1 bundle. To prevent condensation from overflowing the drain pan, keep the drain hose separate from the refrigerant tubing.
- (2) Wrap the armoring tape from the bottom of the outdoor unit to the top of the tubing where it enters the wall. As you wrap the tubing, overlap half of each previous tape turn.
- (3) Clamp the tubing bundle to the wall, using 1 clamp approx. each meter. (Fig. 7-12)

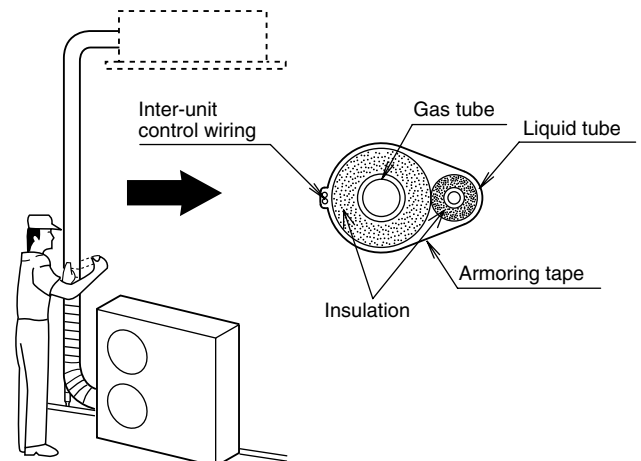

Fig.7-12

NOTE

Do not wind the armoring tape too tightly since this will decrease the heat insulation effect. Also ensure that the condensation drain hose splits away from the bundle and drips clear of the unit and the tubing.

7-5. Finishing the Installation

After finishing insulating and taping over the tubing, use sealing putty to seal off the hole in the wall to prevent rain and draft from entering. (Fig. 7-13)

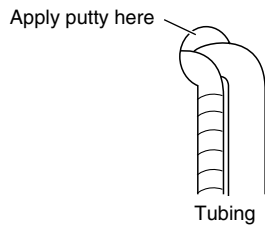

Fig.7-13

8. LEAK TEST, EVACUATION AND ADDITIONAL REFRIGERANT CHARGE

Perform an air-tightness test for this package A/C. Check that there is no leakage from any of the connections.

Air and moisture in the refrigerant system may have undesirable effects as indicated below.

- pressure in the system rises
- operating current rises
- cooling (or heating) efficiency drops
- moisture in the refrigerant circuit may freeze and block capillary tubing
- water may lead to corrosion of parts in the refrigerant system

Therefore, the indoor unit and tubing between the indoor and outdoor unit must be leak tested and evacuated to remove any noncondensables and moisture from the system. (Figs. 8-1 and 8-2)

Manifold gauge

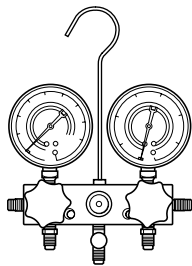

Fig. 8-1

Vacuum pump

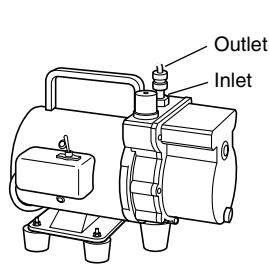

Fig. 8-2

■ Air Purging with a Vacuum Pump (for Test Run) Preparation

Check that each tube (both liquid and gas tubes) between the indoor and outdoor units has been properly connected and all wiring for the test run has been completed. Remove the valve caps from both the gas and liquid service valves on the outdoor unit. Note that both liquid and gas tube service valves on the outdoor unit are kept closed at this stage. (Fig.8-3)

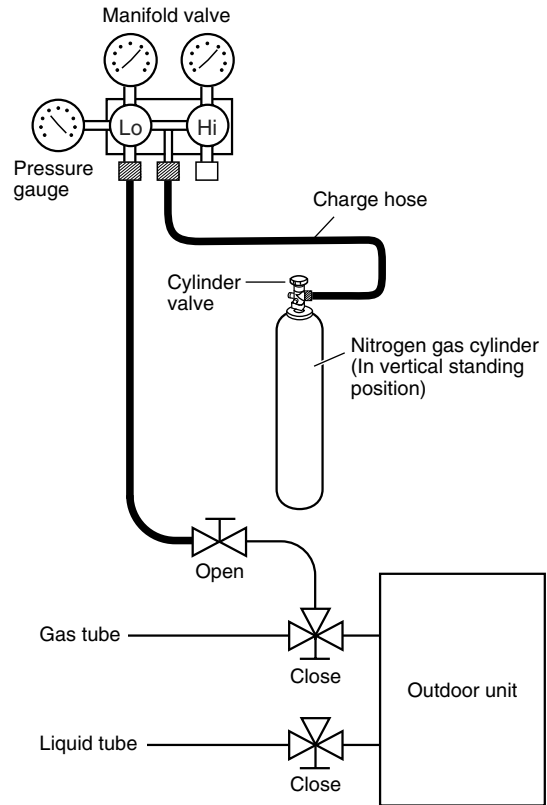

Fig. 8-3

- The refrigerant charge at the time of shipment is only guaranteed sufficient for a tubing length of up to 30 m. The tubing may exceed this length, up to the maximum permitted length; however, an additional charge is necessary for the amount that the tubing exceeds 30 m. (No additional refrigerating machine oil is needed.)

8-1. Leak Test

- (1) With the service valves on the outdoor unit closed, remove the 6.35 mm flare nut and its bonnet on the gas tube service valve. (Save for reuse.)
- (2) Attach a manifold valve (with pressure gauges) and dry nitrogen gas cylinder to this service port with charge hoses.



Use a manifold valve for air purging. If it is not available, use a stop valve for this purpose. The "Hi" knob of the manifold valve must always be kept closed.

- (3) Pressurize the system up to 4.15 MPa (42 kgf/cm²G) with dry nitrogen gas and close the cylinder valve when the gauge reading reaches 4.15 MPa (42 kgf/cm²G). Then, test for leaks with liquid soap.



To avoid nitrogen entering the refrigerant system in a liquid state, the top of the cylinder must be higher than the bottom when you pressurize the system. Usually, the cylinder is used in a vertical standing position.

- (4) Do a leak test of all joints of the tubing (both indoor and outdoor) and both gas and liquid service valves. Bubbles indicate a leak. Wipe off the soap with a clean cloth after a leak test.
- (5) After the system is found to be free of leaks, relieve the nitrogen pressure by loosening the charge hose connector at the nitrogen cylinder. When the system pressure is reduced to normal, disconnect the hose from the cylinder.

8-2. Evacuation

Be sure to use a vacuum pump that includes a function for prevention of back-flow, in order to prevent back-flow of pump oil into the unit tubing when the pump is stopped.

- Perform vacuuming of the indoor unit and tubing. Connect the vacuum pump to the gas tube valve and apply vacuum at a pressure -101kPa (-755 mmHg , 5 Torr) or below. Continue vacuum application for a minimum of 1 hour after the pressure reaches -101kPa (-755 mmHg , 5 Torr).
- (1) Attach the charge hose end described in the preceding steps to the vacuum pump to evacuate the tubing and indoor unit. Confirm that the “Lo” knob of the manifold valve is open. Then, run the vacuum pump.
- (2) When the desired vacuum is reached, close the “Lo” knob of the manifold valve and turn off the vacuum pump. Confirm that the gauge pressure is under -101 kPa (-755 mmHg , 5 Torr) after 4 to 5 minutes of vacuum pump operation. (Fig. 8-4)



Use a cylinder specifically designed for use with R410A.

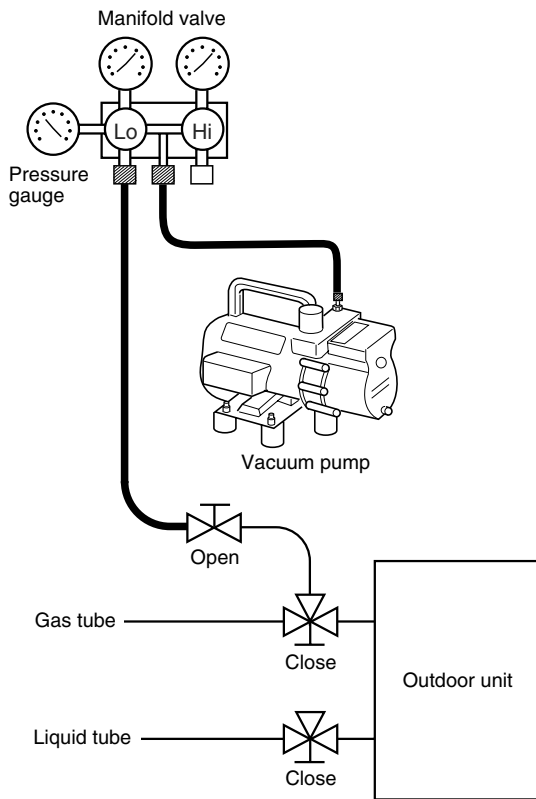

Fig. 8-4

8-3. Charging Additional Refrigerant

- Charging additional refrigerant (calculated from the liquid tube length as shown in “Amount of additional refrigerant charge”) using the liquid tube service valve. (Fig. 8-5)
 - Use a balance to measure the refrigerant accurately.
 - If the additional refrigerant charge amount cannot be charged at once, charge the remaining refrigerant in liquid form by using the gas tube service valve with the system in Cooling mode at the time of test run. (Fig. 8-6)
- * If an additional refrigerant charge has been performed, list the refrigerant tubing length and amount of additional refrigerant charge on the product label (inside the panel).

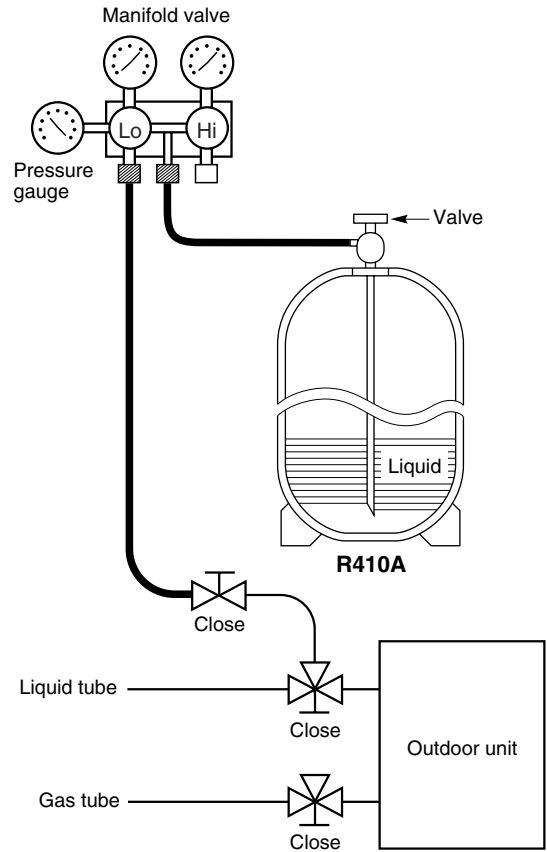

Fig. 8-5

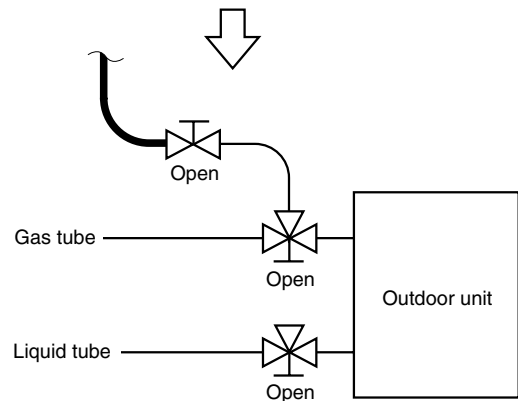

Fig. 8-6

8-4. Finishing the Job

- (1) With a hex wrench, turn the liquid tube service valve stem counterclockwise to fully open the valve.
- (2) Turn the gas tube service valve stem counterclockwise to fully open the valve.



To avoid gas from leaking when removing the charge hose, make sure the stem of the gas tube is turned all the way out (“BACK SEAT”) position.

- (3) Loosen the charge hose connected to the gas tube service port (7.94 mm) slightly to release the pressure, and then remove the hose.
- (4) Replace the 7.94 mm flare nut and its bonnet on the gas tube service port and fasten the flare nut securely with an adjustable wrench or box wrench. This process is very important to prevent gas from leaking from the system.
- (5) Replace the valve caps at both gas and liquid service valves and fasten them securely.

9. HOW TO INSTALL THE CEILING PANEL

■ 4-Way Air Discharge Semi-Concealed Type (4WK Type)

Checking the unit position

- (1) Check that the ceiling hole is within this range:
860 × 860 to 910 × 910 mm
- (2) Use the full-scale installation diagram (from the packaging) that was supplied with the unit to determine the positioning of the unit on the ceiling surface. If the positions of the ceiling surface and unit do not match, air leakage, water leakage, flap operation failure, or other problems may occur.

⚠ CAUTION

- Never place the panel face-down. Either hang it vertically or place it on top of a projecting object. Placing it face-down will damage the surface. (Fig. 9-1)
- Do not touch the flap or apply force to it. (Fig. 9-2) (This may cause flap malfunction.)

Ⓐ must be within the range of 12 – 17 mm.

If not within this range, malfunction or other trouble may result.

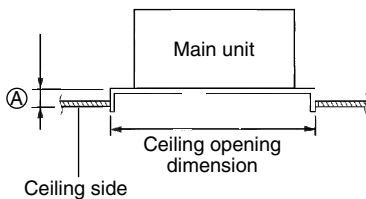

Fig. 9-1

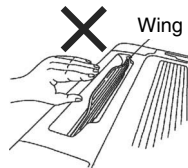

Fig. 9-2

9-1. Before Installing the Ceiling Panel

- (1) Remove the air-intake grille and air filter from the ceiling panel. (Figs. 9-3, 9-4 and 9-5)
 - a) Remove the 2 screws on the latch of the air-intake grille. (Fig. 9-3)
 - b) Slide the air-intake grille catches in the direction shown by the arrows ① to open the grille. (Fig. 9-4)
 - c) With the air-intake grille opened, remove the grille hinge from the ceiling panel by sliding it in the direction shown by the arrow ②. (Fig. 9-5)

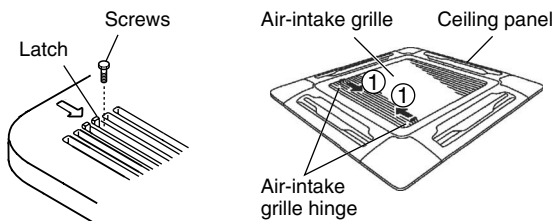

Fig. 9-3

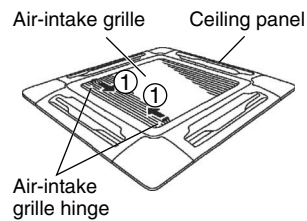

Fig. 9-4

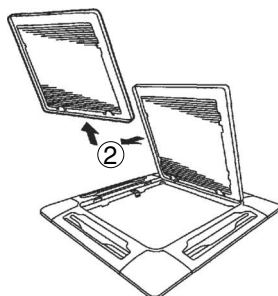

Fig. 9-5

- (2) Removing the corner cover
 - a) Slide the corner cover to the direction shown by the arrow ① to remove the corner cover. (Fig. 9-6)

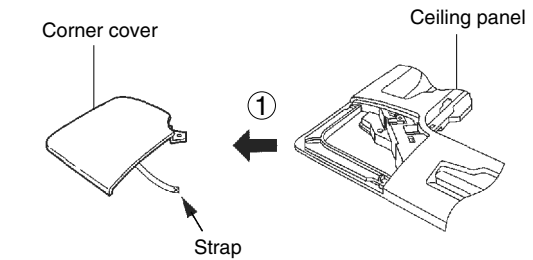
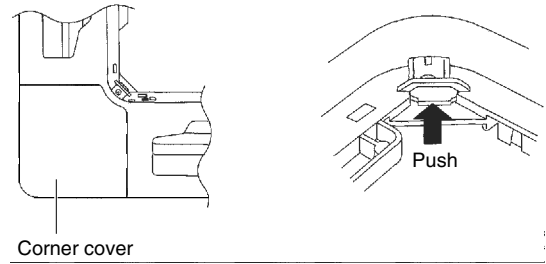

Fig. 9-6

9-2. Installing the Ceiling Panel

The power must be turned ON in order to change the flap angle. (Do not attempt to move the flap by hand. Doing so may damage the flap.)

- (1) Insert the temporary fasteners (stainless steel) on the inside of the ceiling panel into the square holes on the unit to temporarily fasten the ceiling panel in place. (Fig. 9-7)

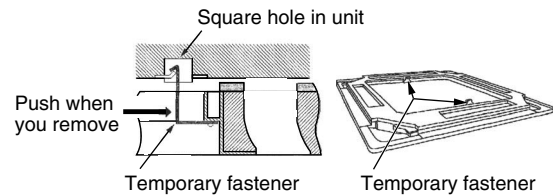

Fig. 9-7

- The ceiling panel must be installed in the correct direction relative to the unit. Align the REF. PIPE and DRAIN marks on the ceiling panel corner with the correct positions on the unit.
 - To remove the ceiling panel, support the ceiling panel while pressing the temporary fasteners toward the outside. (Fig. 9-7)
- (2) Align the panel installation holes and the unit screw holes.
 - (3) Tighten the supplied washer head screws at the 4 panel installation locations so that the panel is attached tightly to the unit. (Fig. 9-8)

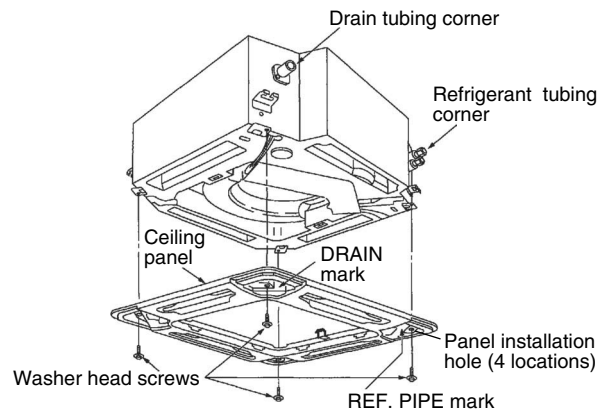

Fig. 9-8

(4) Check that the panel is attached tightly to the ceiling.

- At this time, make sure that there are no gaps between the unit and the ceiling panel, or between the ceiling panel and the ceiling surface. (Fig. 9-9)

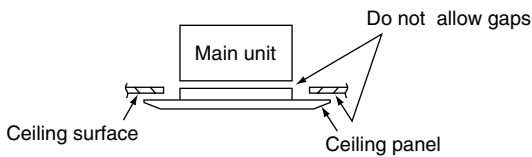

Fig. 9-9

- If there is a gap between the panel and the ceiling, leave the ceiling panel attached and make fine adjustments to the installation height of the unit to eliminate the gap with the ceiling. (Fig. 9-10)

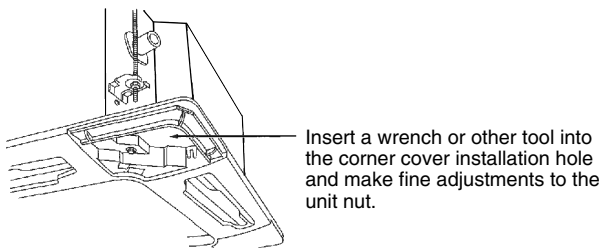
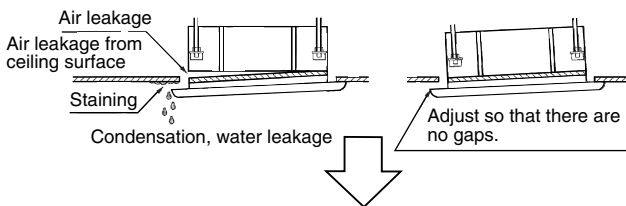

Fig. 9-10

CAUTION

- If the screws are not sufficiently tightened, trouble such as that shown in the figure below may occur. Be sure to tighten the screws securely.
- If a gap remains between the ceiling surface and the ceiling panel even after the screws are tightened, adjust the height of the unit again.



The height of the unit can be adjusted from the ceiling panel corner hole, with the ceiling panel attached, to an extent that does not affect the unit levelness, the drain hose, or other elements. (Fig. 9-11)

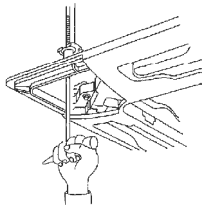

Fig. 9-11

9-3. Wiring the Ceiling Panel

- (1) Open the cover of the electrical component box.
- (2) Connect the 7P wiring connector (red) from the ceiling panel to the connector in the unit electrical component box. (Fig. 9-12)

- If the connectors are not connected, the auto flap will not operate. Be sure to connect them securely.
- Check that the wiring connector is not caught between the electrical component box and the cover.
- Check that the wiring connector is not caught between the unit and the ceiling panel.

(Direction that the unit faces has been changed to facilitate explanation.)

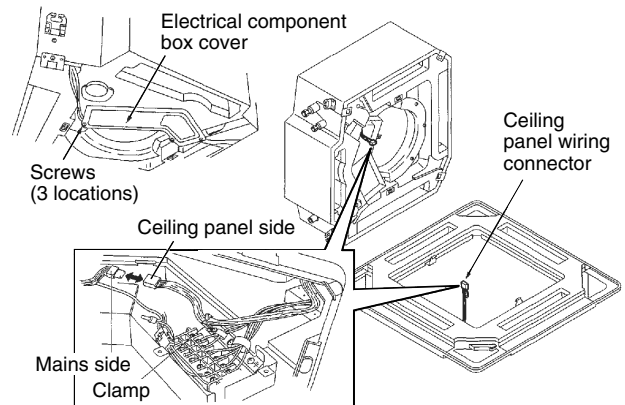

* Pass the wiring connector through the clamp to fasten it in place, as shown in the figure.

Fig. 9-12

9-4. How to Attach the Corner and Air Intake Grille

Attaching the corner cover and air-intake grille

A. Attaching the corner cover

- (1) Check that the safety cord from the corner cover is fastened to the ceiling panel pin. (Fig. 9-13)
- (2) Use the supplied screws to attach the corner cover to the ceiling panel.

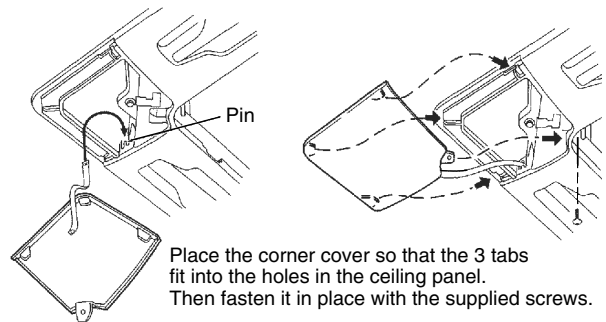

Fig. 9-13

B. Attaching the air-intake grille

- To install the air-intake grille, follow the steps for **Removing the grille** in the reverse order. By rotating the air-intake grille, it is possible to attach the grille onto the ceiling panel from any of 4 directions. Coordinate the directions of the air-intake grilles when installing multiple units, and change the directions according to customer requests.
- **When attaching the air-intake grille, be careful that the flap lead wire does not become caught.**
- **Be sure to attach the safety cord to the ceiling panel unit. This keeps the air intake grille from accidentally dropping. (Fig. 9-14)**

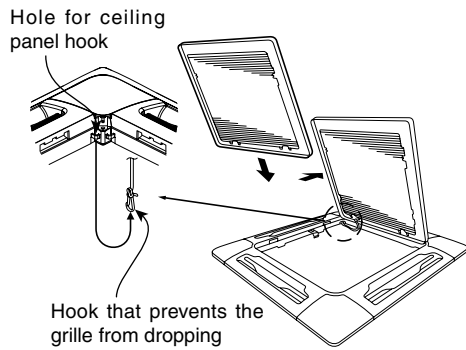

Fig. 9-14

- With this ceiling panel, the directions of the air-intake grille lattices when installing multiple units, and the position of the label showing the company name on the corner panel, can be changed according to customer requests. However, the optional wireless receiver kit can only be installed at the refrigerant-tubing corner of the ceiling unit. (Fig.9-15)

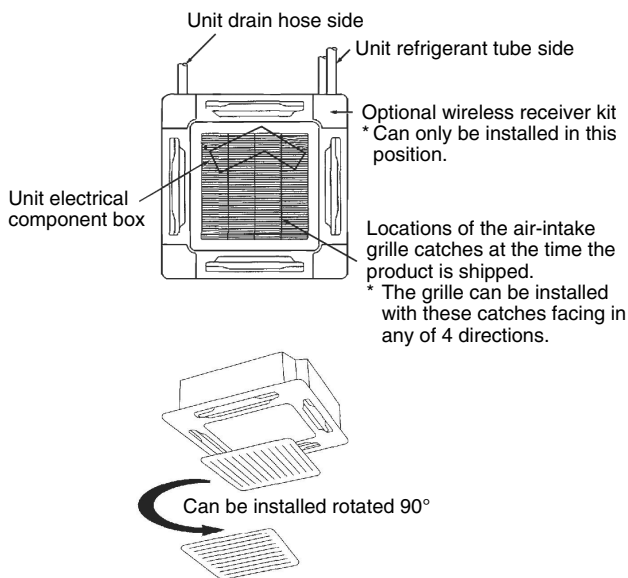

Fig. 9-15

9-5. Checking After Installation

- Check that there are no gaps between the unit and the ceiling panel, or between the ceiling panel and the ceiling surface.
Gaps may cause water leakage and condensation.
- Check that the wiring is securely connected.
If it is not securely connected, the auto flap will not operate. ("P09" is displayed on the remote controller.) In addition, water leakage and condensation may occur.

9-6. When Removing the Ceiling Panel for Servicing

When removing the ceiling panel for servicing, remove the air-intake grille and air filter, disconnect the wiring connector inside the electrical component box, and then remove the 4 mounting screws.

9-7. Adjusting the Auto Flap

The air-direction louver on the ceiling panel outlet can be adjusted as follows.

- Adjust the louver to the desired angle using the remote controller. The louver also has an automatic air-sweeping mechanism.

NOTE

- Never attempt to move the louver by hand.
- Proper airflow depends on the location of the air conditioner, the layout of the room and furniture, etc. If cooling or heating seems inadequate, try changing the direction of the airflow.

10. TEST RUN

10-1. Preparing for Test Run

- Before attempting to start the air conditioner, check the following:
 - (1) All loose matter is removed from the cabinet especially steel filings, bits of wire, and clips.
 - (2) The control wiring is correctly connected and all electrical connections are tight.
 - (3) The protective spacers for the compressor used for transportation have been removed. If not, remove them now.
 - (4) The transportation pads for the indoor fan have been removed. If not, remove them now.
 - (5) The power has been supplied to the unit for at least 5 hours before starting the compressor. The bottom of the compressor should be warm to the touch and the crankcase heater around the feet of the compressor should be hot to the touch. (Fig. 10-1)

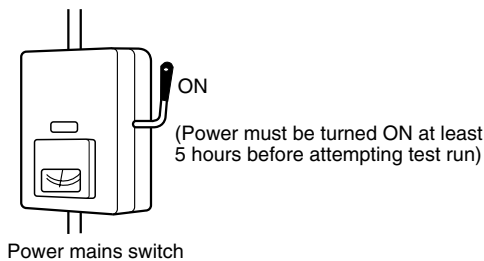

Fig. 10-1

- (6) Both the gas and liquid tube service valves are open. If not, open them now. (Fig. 10-2)

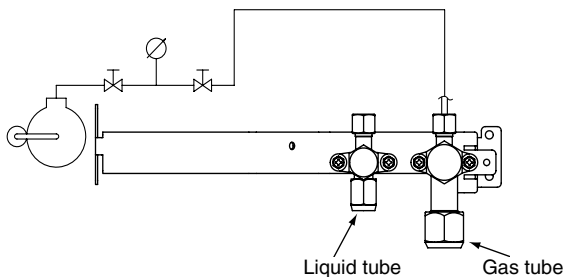

Fig. 10-2

- (7) Request that the customer be present for the test run. Explain the contents of the instruction manual, and then have the customer actually operate the system.
- (8) Be sure to give the instruction manual and warranty certificate to the customer.
- (9) When replacing the control PCB, be sure to make all the same settings on the new PCB as were in use before replacement. The existing EEPROM is not changed, and is connected to the new control PCB.

■ 4WK, C, D Types

10-2. Caution

- This unit may be used in a single-type refrigerant system where 1 outdoor unit is connected to 1 indoor unit, and also in a system where 1 outdoor unit is connected to multiple indoor units (maximum 4).
* If multiple indoor units are used, also refer to "10-8. System Control."
- The indoor and outdoor unit control PCB utilizes a semiconductor memory element (EEPROM). The settings required for operation were made at the time of shipment. Only the correct combinations of indoor and outdoor units can be used.
- This test run section describes primarily the procedure when using the wired remote controller.

10-3. Test Run Procedure

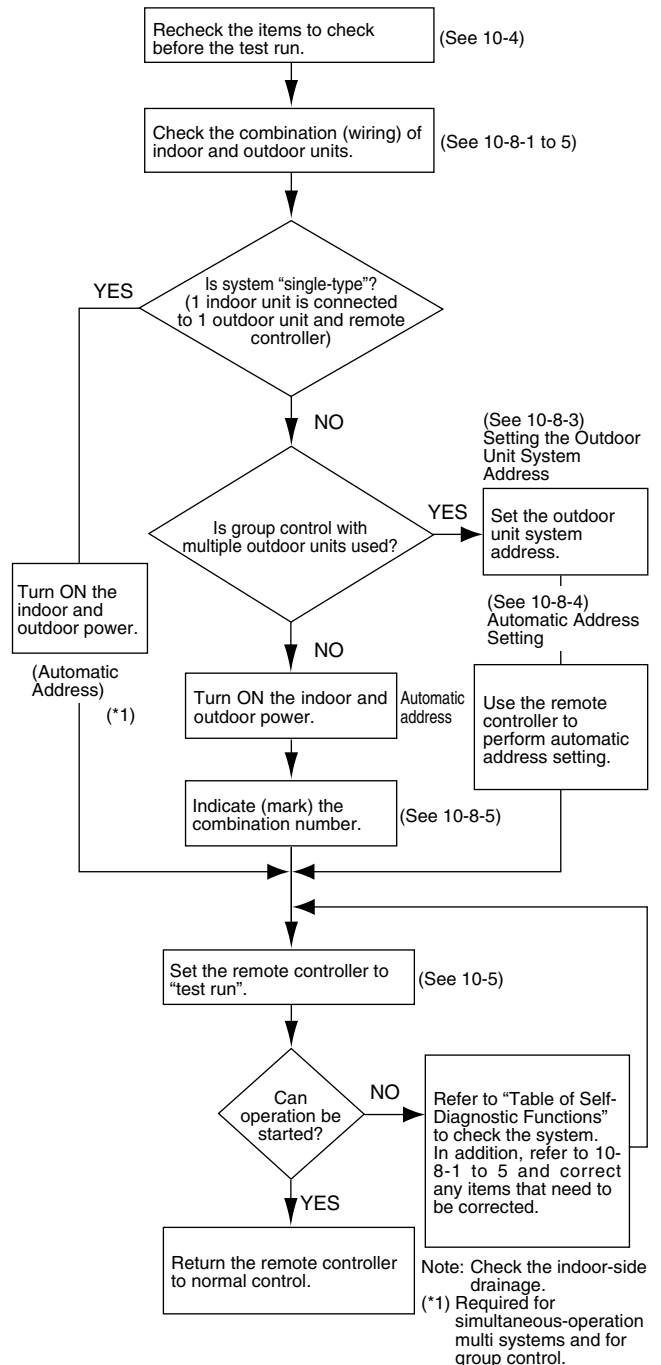





Fig. 10-3

10-4. Items to Check Before the Test Run

- (1) Turn the remote power switch ON at least 12 hours in advance in order to energize the crank case heater.
- (2) Fully open the closed valves on the liquid-tube and gas-tube sides.

10-5. Test Run Using the Remote Controller

- (1) Press and hold the remote controller  button for 4 seconds or longer. Then press the  button.
 - “TEST” appears in the LCD display during the test run.
 - Temperature control is not possible when test run mode is engaged.
(This mode places a large load on the devices. Use it only when performing the test run.)
- (2) Use either Heating or Cooling mode to perform the test run.
 Note: The outdoor unit will not operate for approximately 3 minutes after the power is turned ON or after it stops operating.
- (3) If normal operation is not possible, a code appears on the remote controller LCD display. Refer to the “10-7. Table of Self-Diagnostic Functions and Corrections” and correct the problem.
- (4) After the test run is completed, press the  button again. Check that “TEST” disappears from the LCD display. (This remote controller includes a function that cancels test run mode after a 60-minute timer has elapsed, in order to prevent continuous test run operation.)
- (5) For the test run of an inverter outdoor unit, operate the compressors for a minimum of 10 minutes (in order to check for open phase).
 * When performing a test run using a wired remote controller, operation is possible without attaching the cassette-type ceiling panel. (“P09” will not be displayed.)

10-6. Precautions

- Request that the customer be present when the test run is performed. At this time, explain the operation manual and have the customer perform the actual steps.
- Be sure to pass the manuals and warranty certificate to the customer.
- Check that the 220 – 240 V AC power is not connected to the inter-unit control wiring connector terminal.
 * If 220 – 240 V AC is accidentally applied, the indoor or outdoor unit control PCB fuse will blow in order to protect the PCB. Correct the wiring connections, then disconnect the 2P connectors (indoor: blue, OC) (outdoor: blue, serial 1) that are connected to the PCB, and replace them with 2P connectors (indoor: brown, EMG) (outdoor: brown, serial 2). If operation is still not possible after changing the brown connectors, try cutting the varistor (black) (both indoor and outdoor).
 (Be sure to turn the power OFF before performing this work.)

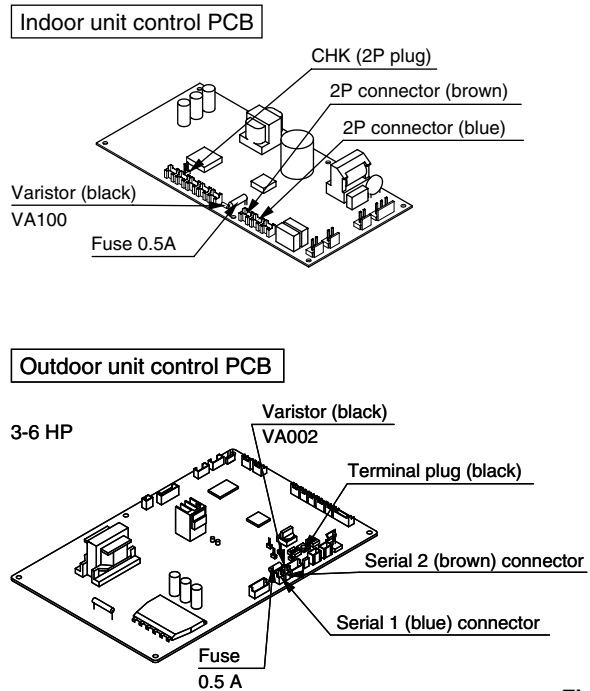

Fig. 10-4

10-7. Table of Self-Diagnostic Functions and Corrections (4WK, C, D Types)

Wired remote controller display	Indoor unit receiver lamp	Cause				Correction
		1:1 connection (single type)	Group connection	Simultaneous-operation multi system (flexible combination)	Control by main-sub remote controllers	
Nothing is displayed	Nothing is displayed	<ul style="list-style-type: none"> Remote controller is not connected correctly. Indoor unit power is not ON. 	<ul style="list-style-type: none"> Remote controller is not connected with indoor unit correctly. Indoor unit power is not ON. 	<ul style="list-style-type: none"> Same at left 	<ul style="list-style-type: none"> Same at left 	<p>Connect the remote controller correctly. Turn ON the indoor unit power.</p>
E01 displayed		<ul style="list-style-type: none"> Automatic address setting has not been completed. Inter-unit control wiring is cut or is not connected correctly. Remote controller is not connected correctly (remote controller receiving failure). 	<ul style="list-style-type: none"> Automatic address setting has not been completed. Inter-unit control wiring is cut or is not connected correctly. Remote controller is not connected with indoor unit correctly. 	<ul style="list-style-type: none"> Same at left 	<ul style="list-style-type: none"> Same at left 	<p>Check the remote controller and inter-unit control wiring. Perform automatic address setting (See 10-8-4).</p>
E02 displayed	Operating lamp is blinking.	<ul style="list-style-type: none"> Remote controller is not connected correctly (failure in transmission from remote controller to indoor unit). 	<ul style="list-style-type: none"> Remote controller is not connected with indoor unit correctly. 	<ul style="list-style-type: none"> Same at left 	<ul style="list-style-type: none"> Same at left 	<p>Connect the remote controller correctly.</p>
E09 displayed		_____	_____	_____	<ul style="list-style-type: none"> 2 remote controllers are set as the main remote controller. 	<p>Refer to 10-8-6 Main-sub remote Control, and make the correct settings.</p>
E14 displayed		_____	_____	<ul style="list-style-type: none"> Remote controller communication wiring is cut or is not connected correctly. 	<ul style="list-style-type: none"> Same at left 	<p>Check the remote controller communication wiring. Perform automatic address setting again.</p>
E04 displayed		<ul style="list-style-type: none"> Indoor-outdoor inter-unit wiring is not connected correctly. 	<ul style="list-style-type: none"> Same at left 	<ul style="list-style-type: none"> Same at left 	<ul style="list-style-type: none"> Same at left 	<p>Connect the wiring correctly.</p>
E06 displayed		_____	<ul style="list-style-type: none"> Indoor-outdoor inter-unit wiring is cut or is not connected correctly. 	<ul style="list-style-type: none"> Same at left 	<ul style="list-style-type: none"> Same at left 	<p>Refer to 10-8 System Control, and make the correct settings.</p>
E15 displayed	Standby lamp is blinking.	<ul style="list-style-type: none"> Indoor unit capacity is too low. 	<ul style="list-style-type: none"> Same at left 	<ul style="list-style-type: none"> Same at left 	<ul style="list-style-type: none"> Same at left 	<p>Check that the total capacities of the indoor and outdoor units are appropriate.</p>
E16 displayed		<ul style="list-style-type: none"> Indoor unit capacity is too high. 	<ul style="list-style-type: none"> Same at left 	<ul style="list-style-type: none"> Same at left 	<ul style="list-style-type: none"> Same at left 	<p>Check that the indoor unit power is ON, and that the inter-unit control wiring is connected correctly.</p>
E20 displayed		<ul style="list-style-type: none"> No serial signal is being received at all from the indoor units. 	<ul style="list-style-type: none"> Reversed phase in the outdoor unit single phase or open phase in the 3-phase power at one of the outdoor units in the group. 	<ul style="list-style-type: none"> Same at left 	<ul style="list-style-type: none"> Same at left 	<p>Reverse 2 phases of the outdoor unit 3-phase power and connect them correctly. Check that the CT sensor is not disconnected, and make sure it is inserted. Fill up the gas appropriately.</p>
P05 displayed	Operation lamp and Standby lamp are blinking alternately.	<ul style="list-style-type: none"> Reversed phase in the outdoor unit single-phase or open phase in the outdoor unit 3-phase power. Insufficient gas 	<ul style="list-style-type: none"> Reversed phase in the outdoor unit single phase or open phase in the 3-phase power at one of the outdoor units in the group. 	<ul style="list-style-type: none"> Same at left 	<ul style="list-style-type: none"> Same at left 	<p>Check that the indoor unit power is ON, and that the inter-unit control wiring is connected correctly.</p>
L02 displayed	Both the Operation lamp and Standby lamp are blinking together.	<ul style="list-style-type: none"> Indoor-outdoor unit type mismatch. 	<ul style="list-style-type: none"> Same at left 	<ul style="list-style-type: none"> Same at left 	<ul style="list-style-type: none"> Same at left 	<p>Check that the indoor and outdoor unit types are correct.</p>
L13 displayed		_____	_____	<ul style="list-style-type: none"> Remote controller communication wiring is connected to the indoor unit, however it is set for individual operation. 	<ul style="list-style-type: none"> Same at left 	<p>Perform automatic address setting (See 10-8).</p>
L07 displayed	Operation lamp and Standby lamp are blinking together.	_____	_____	<ul style="list-style-type: none"> Indoor unit ceiling panel connector is not connected correctly. 	<ul style="list-style-type: none"> Same at left 	<p>Connect the indoor unit ceiling panel connector correctly.</p>
P09 displayed	Timer lamp and Standby lamp are blinking alternately.	<ul style="list-style-type: none"> The indoor unit ceiling panel connector is not connected correctly. 	<ul style="list-style-type: none"> Ceiling panel connector at one of the indoor units in the group is not connected correctly. 	<ul style="list-style-type: none"> Indoor unit fan trouble. 	<ul style="list-style-type: none"> Same at left 	<p>Check whether the fan holder is loose. Check the wiring between the DC fan and the PCB.</p>
P12 displayed		<ul style="list-style-type: none"> Indoor unit DC fan trouble. 	<ul style="list-style-type: none"> DC fan trouble at one of the indoor units in the group. 	<ul style="list-style-type: none"> Indoor unit fan trouble. 	<ul style="list-style-type: none"> Same at left 	<p>Check the refrigerant cycle (for gas leaks).</p>
P15 displayed	Operation lamp and Standby lamp are blinking alternately.	<ul style="list-style-type: none"> No gas 	<ul style="list-style-type: none"> Same at left 	<ul style="list-style-type: none"> Same at left 	<ul style="list-style-type: none"> Same at left 	

10-8. System Control

System control refers to the link wiring connection for control of simultaneous-operation multi systems, group control, and main-sub remote controller control.

10-8-1. Basic wiring diagram 1

Single type and simultaneous-operation multi system

- Simultaneous-operation multi system
Up to 4 (Double-Twin) indoor units can be connected to 1 outdoor unit for operation.
(However, coordinate the outdoor unit capacity and the total capacity of the indoor units.)
(It is not possible to connect individual remote controllers for independent operation.)
- Be careful to avoid miswiring when connecting the wires.
(Miswiring will damage the units.)

(for single-phase outdoor unit)

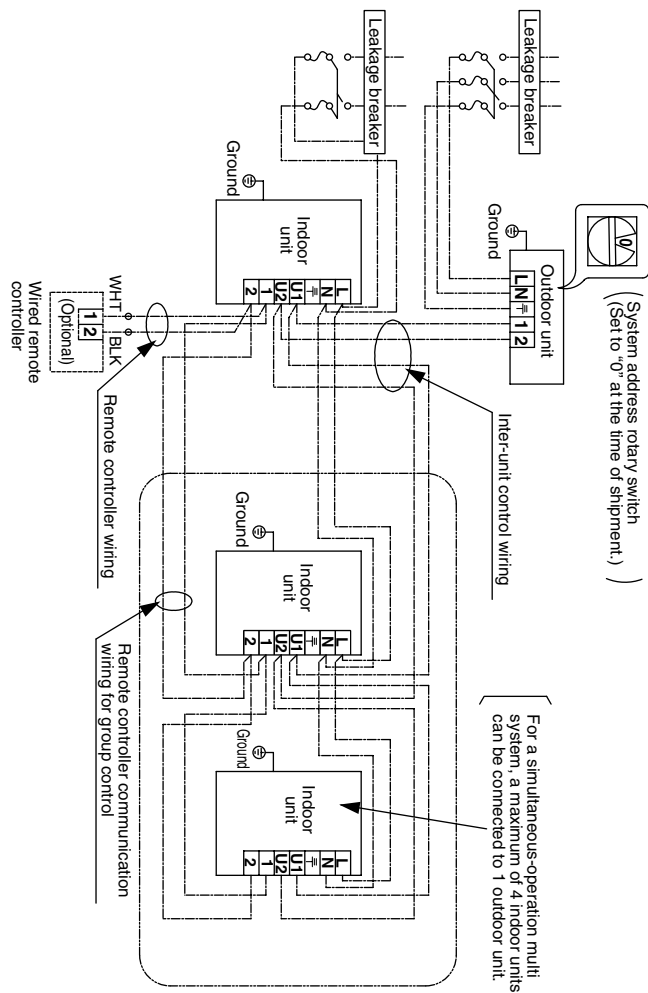

Fig. 10-5

10-8-2. Basic wiring diagram 2

Group control (when a central control device is not used)

- Simultaneous-operation multi system
Up to 4 (Double-Twin) indoor units can be connected to 1 outdoor unit for operation.
(However, coordinate the outdoor unit capacity and the total capacity of the indoor units.)
(It is not possible to connect individual remote controllers for independent operation.)
A maximum of 8 indoor units can be connected to 1 remote controller.
When 2 or 3 indoor units are connected to each outdoor unit in the refrigerant system, set the system address (refrigerant tubing system address) before turning on the remote power switch. (Refer to 10-8-3. Setting the outdoor unit system addresses.)
(Set using the system address rotary switch on the outdoor unit control PCB.)

(for single-phase outdoor unit)

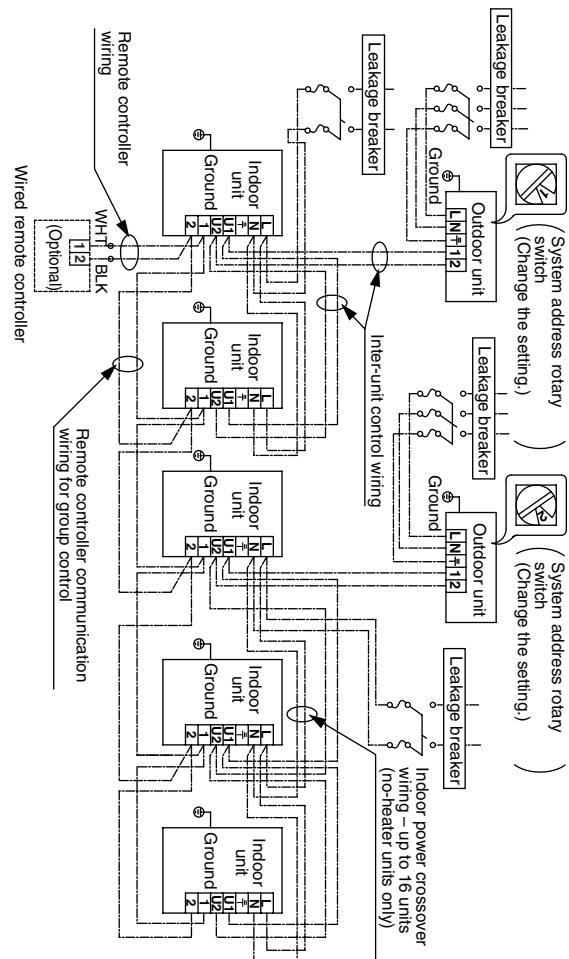

Fig. 10-6

(Wiring procedure)

- (1) Connect the remote controller to the indoor unit remote controller wiring terminal plate (1, 2). (Remote controller wiring)
- (2) Connect the indoor units (U1, U2) and the outdoor units (1, 2). Connect the other outdoor units and indoor units (with different refrigerant systems) in the same way. (Inter-unit control wiring)
Connect the remote controller communication wiring to the indoor units (U1, U2) for each refrigerant system. (Inter-unit control wiring)
- (3) Connect the remote controller communication wiring (2 wires) from the remote controller wiring terminal plate (1, 2) on the indoor unit (unit where the remote controller is connected) to the remote controller terminal plates (1, 2) on the other indoor units. (Remote controller communication wiring)
- (4) Turn ON both the indoor and outdoor unit power and perform automatic address setting from the remote controller. (For the automatic address setting procedure, refer to 10-8-4.)

NOTE

- * Models with auxiliary heaters cannot be used for crossover wiring of the indoor unit power wires. (Use a pull box to divide the wiring.)

Be sure to use the indoor unit temperature sensor (body sensor) when using this control. (Status at shipment.)

10-8-3. Setting the outdoor unit system addresses

For basic wiring diagram 2 (Set the system addresses: 1, 2, 3...)

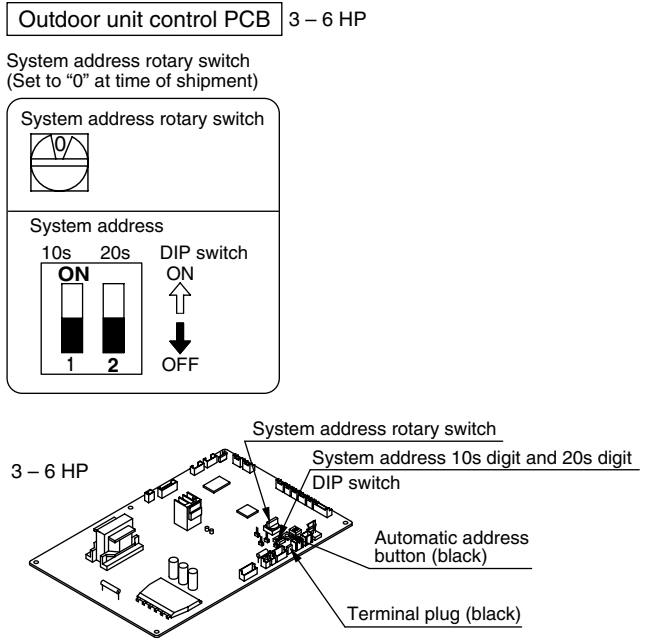

Fig. 10-7

System address No.	System address 10s digit (2P DIP switch)	System address 1s place (Rotary switch)
0 Automatic address (Setting at shipment = "0")	Both OFF 	"0" setting
1 (If outdoor unit is No. 1)	Both OFF 	"1" setting
2 (If outdoor unit is No. 2)	Both OFF 	"2" setting
11 (If outdoor unit is No. 11)	10s digit ON 	"1" setting
21 (If outdoor unit is No. 21)	20s digit ON 	"1" setting
30 (If outdoor unit is No. 30)	10s digit and 20s digit ON 	"0" setting

10-8-4. Automatic address setting using the remote controller

When the outdoor unit shown in "10-8-2. Basic wiring diagram 2" is used for group control of multiple units, use the remote controller to perform automatic address setting. (During automatic address setting, "SETTING" blinks on the remote controller display.)

- Press the remote controller timer time button and button simultaneously. (Hold for 4 seconds or longer.) Then press the button. (Item code "AA" appears: All systems automatic address setting.)
(Automatic address setting is performed in sequence for all outdoor units from No. 1 to No. 30. When automatic address setting is completed, the units return to normal stopped status.)
- To select each refrigerant system individually and perform automatic address setting, press the remote controller timer time button and button simultaneously. (Hold for 4 seconds or longer.) Then press either of the temperature setting / buttons.
(Item code "A1" appears: Individual system automatic address setting)
Use either the or button to select the outdoor unit to perform automatic address setting for. (R.C.1 is displayed.) Then press the button. (Automatic address setting is performed for refrigerant system 1.) When automatic address setting for system 1 is completed, the system returns to normal stopped status.
Again press the remote controller timer time button and the button simultaneously.
Then in the same way as above (use the button to display "R.C.2"), select the next system and perform automatic address setting.

10-8-5. Indicating (marking) the indoor and outdoor unit combination number

Indicate (mark) the number after automatic address setting is completed.

- (1) So that the combination of each indoor unit can be easily checked when multiple units are installed, ensure that the indoor and outdoor unit numbers correspond to the system address number on the outdoor unit control PCB, and use a magic marker or similar means which cannot be easily erased to indicate the numbers in an easily visible location on the indoor units (near the indoor unit nameplates).
Example: (Outdoor) 1 – (Indoor) 1, 2...
(Outdoor) 2 – (Indoor) 1, 2...
- (2) These numbers will be needed for maintenance. Be sure to indicate them.
* Use the remote controller to check the addresses of the indoor units. Press and hold the button and button for 4 seconds or longer (simple settings mode). Then press the button and select the indoor address. (Each time the button is pressed, the address changes as follows: 1-1, 1-2, ... 2-1, 2-2, ...) The indoor unit fan operates only at the selected indoor unit. Confirm that correct fan is operating, and indicate the address on the indoor unit.
Press the button again to return to the normal remote controller mode.
For details, refer to the separate manual.

10-8-6. Main-sub remote controller control

Control using 2 remote controller switches

Main-sub remote controller control refers to the use of 2 remote controllers to control 1 or multiple indoor units. (A maximum of 2 remote controllers can be connected.)

● Connecting 2 remote controllers to control 1 indoor unit

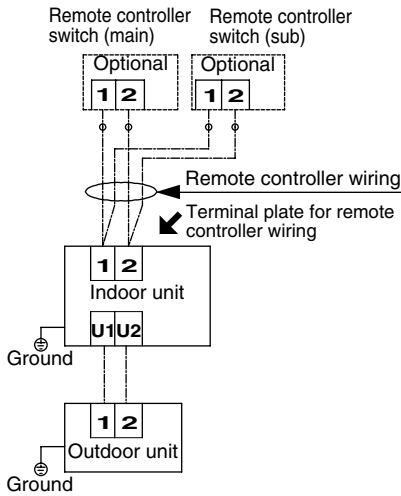

● Connecting 2 remote controllers to control a simultaneous-operation multi system

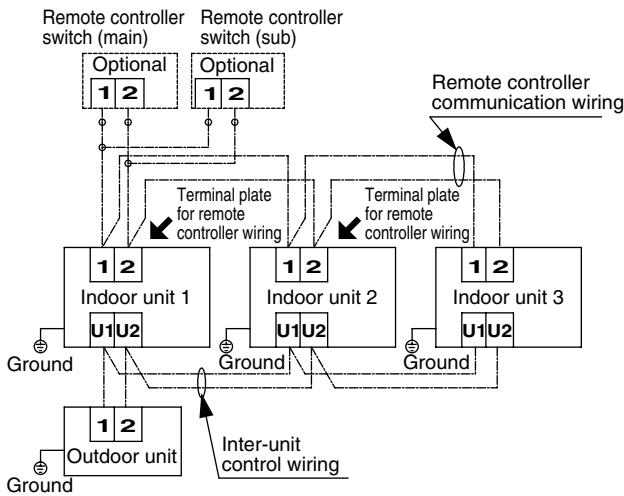

● Remote controller setting mode

To set the remote controller main/sub setting or change the sensor, follow the steps below.

- (1) Press both and buttons on the remote controller for more than 4 seconds together.
- (2) Select CODE No. with / () buttons.
- (3) Change DATA with / (TIMER) buttons.
- (4) Press . Finally, press .

* DATA is memorized in the RCU. (DATA setting will not be changed even when the power is turned off.)

* Make sure to set [Normal] for RCU. CK.

CODE ITEM	ITEM	DATA	
		0000	0001
01	RCU. Main/Sub	Sub	Main
02	Clock display	24 hours	12 hours (AM/PM)
08	RCU. CK	RCU. CK	Normal
0A	Room temperature sensor	Main unit	RCU

■ HW Type

10-9. Caution

- This unit may be used in a single-type refrigerant system where 1 outdoor unit is connected to 1 indoor unit, and also in a system where 1 outdoor unit is connected to multiple indoor units (maximum 4).

* If multiple indoor units are used, also refer to “10-16. System Control”.

- The indoor and outdoor unit control PCB utilizes a semiconductor memory element (EEPROM). The settings required for operation were made at the time of shipment. Only the correct combinations of indoor and outdoor units can be used.

10-10. Test Run Procedure

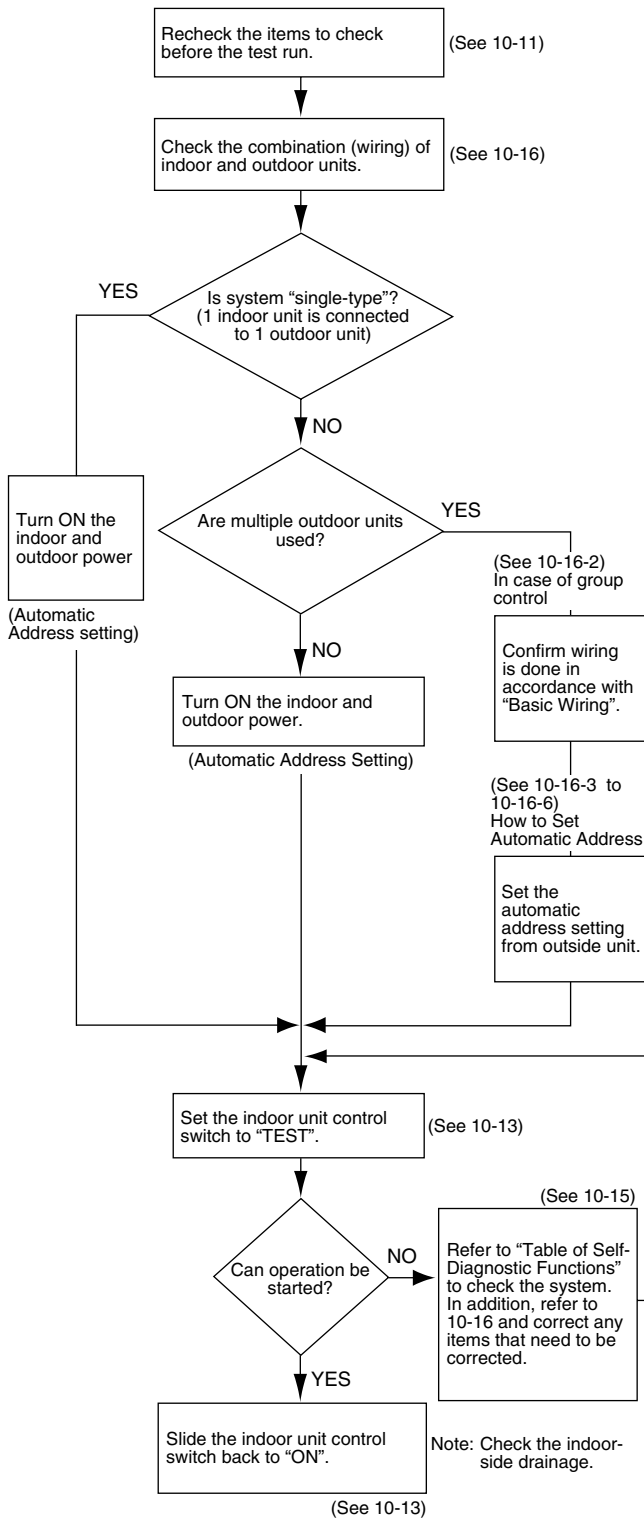



Fig. 10-8

10-11. Items to Check Before the Test Run

- (1) Turn the remote power switch ON at least 12 hours in advance in order to energize the crank case heater.
- (2) Fully open the closed valves on the liquid-tube and gas-tube sides.

10-12. Preparation for Test Run

10-12-1. Switching the temperature sensor

- Temperature sensors are contained in the indoor unit and wireless remote controller. One or the other of the temperature sensors is used for operation.
- If  (body sensor) appears on the LCD display of the wireless remote controller, then the indoor unit body sensor is used for operation.
To switch to the remote controller sensor, open the remote controller cover and press the SENSOR button once. The  (body sensor) display disappears and the remote control sensor is used for operation.

NOTE

- Even if the remote controller sensor is selected, the sensor will be automatically switched to the indoor unit body sensor if no temperature signal has been received from the remote controller for 10 minutes. Install the remote controller in a position where the signal can be reliably received by the unit.
- When group control is engaged, be sure to use the body sensor.

10-12-2. Using the remote controller

- Face the remote controller toward the receiver (on the main unit). (Fig. 10-9)
- The signal can be received up to a distance of approximately 8 m.
Use this distance as a guide. This distance may vary somewhat depending on the battery capacity and other factors.
- Be sure that there are no objects between the remote controller and the receiver which may block the signal.
- The unit beeps when a signal is received correctly. (For operation start only, the unit beeps twice.)
- Do not drop, throw, or wash the remote controller.
- Do not place the remote controller in locations exposed to direct sunlight or nearby a stove.

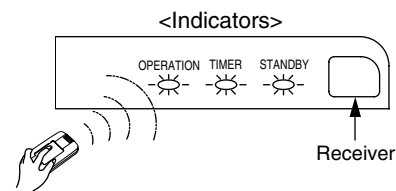
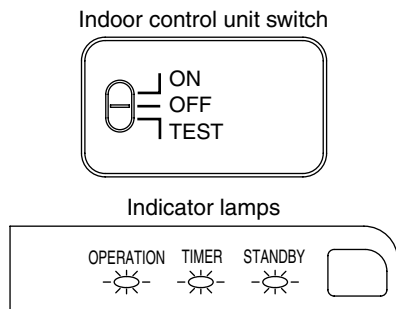

Fig. 10-9

10-13. Test Run

Using the control unit

- (1) Change the indoor control unit switch from “ON” → “TEST”.
(The outdoor unit will not operate for 3 minutes after the power is turned ON and after operation is stopped.)
- (2) All the indicator lamps blink while the test run is in progress.
- (3) Temperature control is not possible during the test run.
- (4) If correct operation is not possible, the trouble will be indicated by the indicator lamps. Refer to “10-15. Table of Self-Diagnostic Functions and Corrections” and correct the problem.
- (5) After the test is completed, change the control unit switch from “TEST” → “ON”. Confirm that the indicator lamps have stopped blinking. (A function is included which cancels the test run after a 60-minute timer has elapsed, in order to prevent continuous test run operation.)



NOTE

- This mode places a large load on the devices. Use it only for performing test runs.
- A test run is not possible if the power is turned ON with the switch in the TEST position.
After the power has been turned ON, change the switch once to ON or OFF, then switch it back to the TEST position.

10-14. Precautions

- Request that the customer be present when the test run is performed. At this time, explain the operation manual and have the customer perform the actual steps.
- Be sure to pass the manuals and warranty certificate to the customer.
- Check that the 220 – 240 V AC wiring is not connected to the inter-unit control wiring connector terminal.
* If 220 – 240 V AC is accidentally applied, the indoor or outdoor unit control PCB fuse (0.5 A for both indoor and outdoor units) will blow in order to protect the PCB. Correct the wiring connections, then disconnect the 2P connectors (indoor: blue) (outdoor: blue, serial 1) that are connected to the PCB, and replace them with 2P connectors (indoor: brown) (outdoor: brown, serial 2).
If operation is still not possible after changing the brown connectors, try cutting the varistor (black) (both indoor and outdoor).
(Be sure to turn the power OFF before performing this work.) (Fig. 10-10)

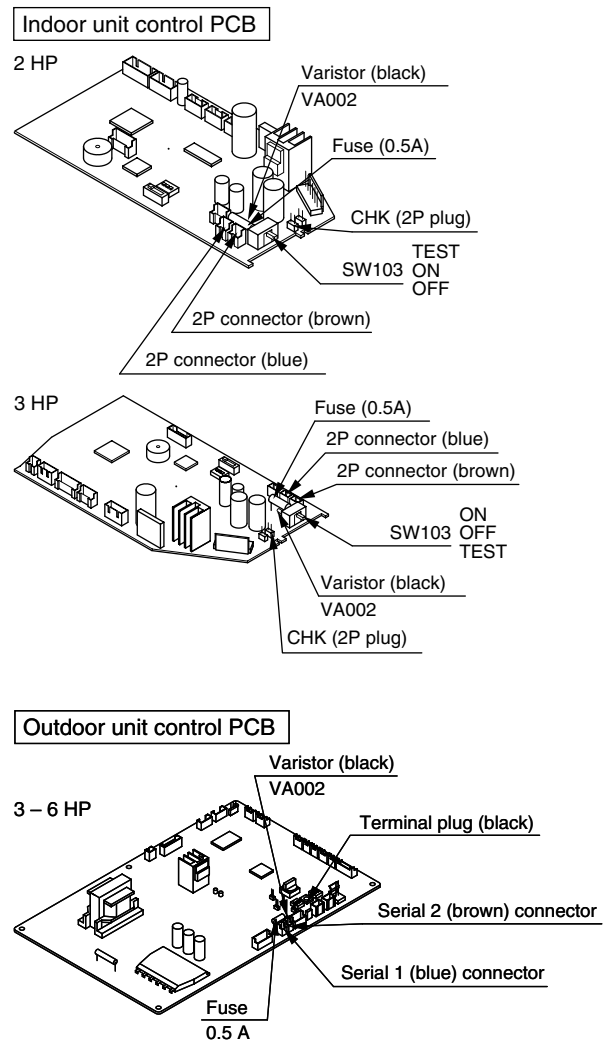

Fig. 10-10

10-15. Table of Self-Diagnostic Functions and Corrections

Wired remote controller display (Field supply)	Indoor unit receiver lamp	Cause		Correction
		1:1 connection (Single type)	Group connection (Simultaneous multi system)	
Nothing is displayed	Nothing is displayed	<ul style="list-style-type: none"> Indoor operation switch is OFF. Indoor unit power is not ON. 	<ul style="list-style-type: none"> Same at left. 	<ul style="list-style-type: none"> Set the indoor operation switch ON. Turn ON the indoor unit power.
E01 displayed	Operating lamp is blinking.	<ul style="list-style-type: none"> Automatic address setting has not been completed. Inter-unit control wiring is cut or is not connected correctly. 	<ul style="list-style-type: none"> Same at left. 	<ul style="list-style-type: none"> Check the inter-unit control wiring. Perform automatic address setting (See 10-16).
E14 displayed		<ul style="list-style-type: none"> Remote controller communication wiring is cut or is not connected correctly. 	<ul style="list-style-type: none"> Check the remote controller communication wiring. Perform automatic address setting again. 	
E04 displayed	Standby lamp is blinking.	<ul style="list-style-type: none"> Indoor-outdoor inter-unit wiring is not connected correctly. 	<ul style="list-style-type: none"> Same at left. 	<ul style="list-style-type: none"> Connect the wiring correctly.
E06 displayed		<ul style="list-style-type: none"> Inter-unit control wiring is cut or is not connected correctly. 	<ul style="list-style-type: none"> Refer to 10-16 System Control, and make the correct settings. 	
E15 displayed		<ul style="list-style-type: none"> Indoor unit capacity is too low. 	<ul style="list-style-type: none"> Same at left. 	<ul style="list-style-type: none"> Check that the total capacities of the indoor and outdoor units are appropriate.
E16 displayed		<ul style="list-style-type: none"> Indoor unit capacity is too high. 	<ul style="list-style-type: none"> Same at left. 	<ul style="list-style-type: none"> Reverse 2 phases of the outdoor unit 3-phase power and connect them correctly.
P05 displayed	Operation lamp and Standby lamp are blinking alternately.	<ul style="list-style-type: none"> Reversed phase in the outdoor unit single-phase or open phase in the outdoor unit 3-phase power. 	<ul style="list-style-type: none"> Same at left. 	<ul style="list-style-type: none"> Connect the units correctly.
L02 displayed	Both the Operation lamp and Standby lamp are blinking together.	<ul style="list-style-type: none"> Indoor-outdoor unit type mismatch. 	<ul style="list-style-type: none"> Same at left. 	<ul style="list-style-type: none"> Connect the units correctly.
L13 displayed		<ul style="list-style-type: none"> Indoor-outdoor units are not setting correctly. 	<ul style="list-style-type: none"> Same at left. 	<ul style="list-style-type: none"> Connect the units correctly.
L04 displayed		<ul style="list-style-type: none"> Outdoor unit address is duplicated. 	<ul style="list-style-type: none"> Connect the units correctly. 	
L07 displayed	<ul style="list-style-type: none"> Remote controller communication wiring is connected to the indoor unit, however, it is set for individual operation. 	<ul style="list-style-type: none"> Perform automatic address setting (See 10-16). 		
P15 displayed	Operation lamp and Standby lamp are blinking alternately.	<ul style="list-style-type: none"> No gas 	<ul style="list-style-type: none"> Same at left. 	<ul style="list-style-type: none"> Check the refrigerant cycle (for gas leaks).

10-16-2. Basic wiring diagram 2

Group control (when a central control device is not used)

- A maximum of 8 indoor units can be connected to a single remote controller.

Example: In a refrigerant system where 2 or 3 indoor units are connected to 1 outdoor unit, set the new system address (refrigerant system address) before turning ON the remote power switch. (Refer to 10-16-3.)
(Set using the system address black rotary switch on the outdoor unit control PCB.)

(for single-phase outdoor unit)

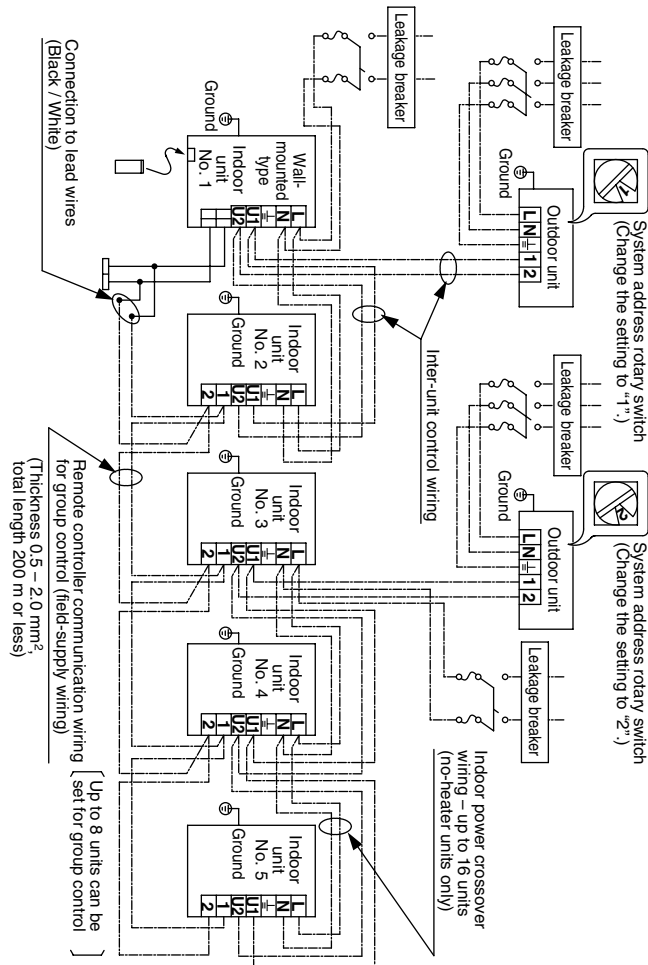

Fig. 10-12

1. Wall-mounted units do not include a terminal plate for connecting a remote controller.
2. For group control of wall-mounted units, connect the remote controller communication wiring to the remote controller connector (2P) on the main unit, as shown in the diagram.

(Wiring procedure)

- (1) Set the No. 1 wall-mounted indoor unit so that it can be operated by the wireless remote controller. (This is set at the time of shipment.)
On the indoor unit control PCBs, set the No. 2 and following wall-mounted units to the sub remote controller. (Refer to 10-16-5.)
- (2) Connect the crossover wiring to 1 and 2 on the remote controller wiring terminal plates of the No. 1 indoor unit and the other indoor units (as shown in Basic wiring diagram 2).
- (3) Connect the inter-unit control wiring to 1 and 2 on the No. 1 indoor unit terminal plate, and to 1 and 2 on the outdoor unit terminal plate.
Connect the wiring in the same way from the other outdoor units to U1 and U2 on the indoor units terminal plates (different refrigerant system).
- (4) Perform automatic address setting from the outdoor unit. (For the automatic address setting procedure, refer to 10-16-4.)

NOTE

- * Models with auxiliary heaters cannot be used for "crossover wiring" of the indoor unit power wires. (Use a pull box to divide the wiring.)
- * Be sure to use the indoor unit temperature sensor (body sensor) when using this control. (Status at shipment)

10-16-3. Setting the outdoor unit system addresses

For basic wiring diagram 2 (Set the system addresses: 1, 2,...)

Outdoor unit control PCB 3 – 6 HP

System address rotary switch
(Set to "0" at time of shipment)

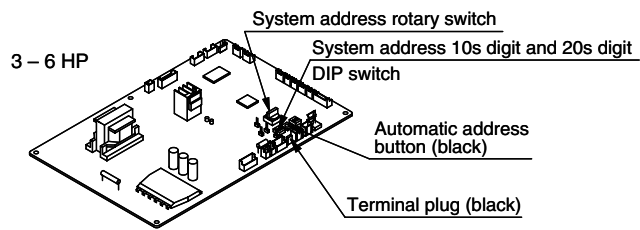
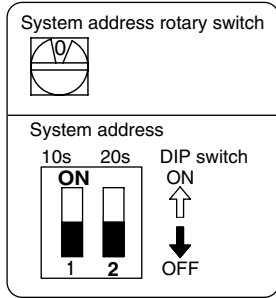

Fig. 10-13

System address No.	System address 10s digit (2P DIP switch)	System address 1s place (Rotary switch)
0 Automatic address (Setting at shipment = "0")	Both OFF 	"0" setting
1 (If outdoor unit is No. 1)	Both OFF 	"1" setting
2 (If outdoor unit is No. 2)	Both OFF 	"2" setting
11 (If outdoor unit is No. 11)	10s digit ON 20s digit OFF 	"1" setting
21 (If outdoor unit is No. 21)	10s digit OFF 20s digit ON 	"1" setting
30 (If outdoor unit is No. 30)	10s digit ON 20s digit ON 	"0" setting

10-16-4. Automatic address setting from the outdoor unit

When there are multiple outdoor units as shown in basic wiring diagram 2

- If the power can be turned ON separately for the indoor and outdoor units in each system (indoor unit addresses can be set without operating the compressor):

- (1) Turn ON the indoor and outdoor unit power for refrigerant system 1.
Press and hold the automatic address setting button (black) for 1 second or longer at the outdoor unit where the power was turned ON.



Communication for automatic address setting begins. LED 1 and 2 on the outdoor unit control PCB blink alternately, and turn OFF when address setting is completed.



<Approximately 4 – 5 minutes are required.>

- (2) Next, turn ON the power only at the indoor and outdoor units in a different system. Press the automatic address setting button (black) on the outdoor unit.



LED 1 and 2 on the outdoor unit control PCB blink alternately, and turn OFF when address setting is completed. Repeat the same procedure for each system and complete automatic address setting.



- (3) Operation using the remote controller is now possible.

10-16-5. Indoor unit remote controller main-sub setting

- When multiple wall-mounted indoor units are installed for group control in a simultaneous-operation multi system, set the control PCB at the No. 2 and following wall-mounted units to "Sub remote control".
If a wired remote controller is used, set the wired remote controller to "Sub".
If 2 wireless remote controllers are used, set the wireless PCB (DIP switch) on the second remote controller to "Sub".

10-16-6. Indoor unit address setting

- If multiple single-type units are installed in the same room, the addresses can be set to prevent signal interference. By coordinating the numbers of the indoor unit (wireless PCB) and remote controller addresses, up to 6 indoor units can be controlled independently by their respective remote controllers. Independent control is not possible when a simultaneous-operation multi system is used.
- Checking the addresses
Press the remote controller address button to display the current address on the remote controller display.
If this address matches the indoor unit (wireless PCB) address, the buzzer will sound.
(If ALL is set, the buzzer will always sound.)
If ALL is set, operation is possible regardless of the indoor unit address.
Point the remote controller toward the receiver (indoor unit) that you wish to operate, and send the operation signal.
- Remote controller address setting
Press and hold the address button for 4 seconds or longer to display the address on the remote controller display. The current address starts blinking.
The address changes each time the remote controller address button is pressed: ALL → 1 → 2 → 3 → ... → 6.
Set the address to match the remote controller you wish to operate.
When the SET button is pressed, the address stops blinking and displays for 5 seconds. The buzzer sounds if the address matches the indoor unit.

Remote controller address display	Address ALL	Address 1	Address 2	Address 3
Indoor unit PCB address, DIP switch				

For address switches 1, 2, and 3, turn DIP switch 1 to OFF.
For address switches 4, 5, and 6, turn DIP switch 1 to ON.

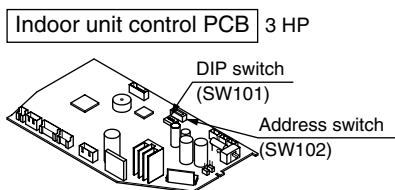
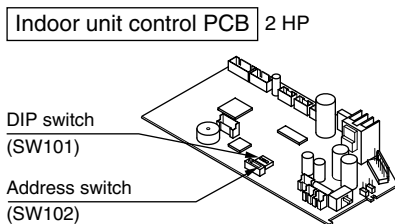
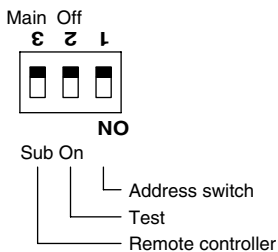

■ 4WK, C, D Types (for Link Wiring)

10-17. Caution

This unit may be used in a single-type refrigerant system where 1 outdoor unit is connected to 1 indoor unit, and also in a system where 1 outdoor unit is connected to multiple indoor units (maximum 4 < Double-Twin >).

- This test run explanation describes primarily the procedure when using the wired remote controller.
- If link wiring is used, set the outdoor unit system address to allow the combination of indoor and outdoor units to be identified. At the same time, indicate the indoor-outdoor unit combination number in a location where it can be checked easily (near the indoor unit nameplates). (This number will be required for subsequent maintenance. Refer to 10-22-2, -3, -4.)
- Request that the customer be present when the test run is performed. At this time, explain the operation manual and have the customer perform the actual steps.
- Be sure to pass the manuals and warranty certificate to the customer.
- Check that the 220 – 240 V AC wiring is not connected to the inter-unit control wiring connector terminal. If 220 – 240 V AC is accidentally applied, the indoor or outdoor unit control PCB fuse (0.5 A for both indoor and outdoor units) will blow in order to protect the PCB. Correct the wiring connections, then disconnect the 2P connectors (indoor: blue, OC) (outdoor: blue, serial 1) that are connected to the PCB, and replace them with 2P connectors (indoor: brown, EMG) (outdoor: brown, serial 2). If operation is still not possible after changing the brown connectors, try cutting the varistor (black) (both indoor and outdoor).
(Be sure to turn the power OFF before performing this work.)

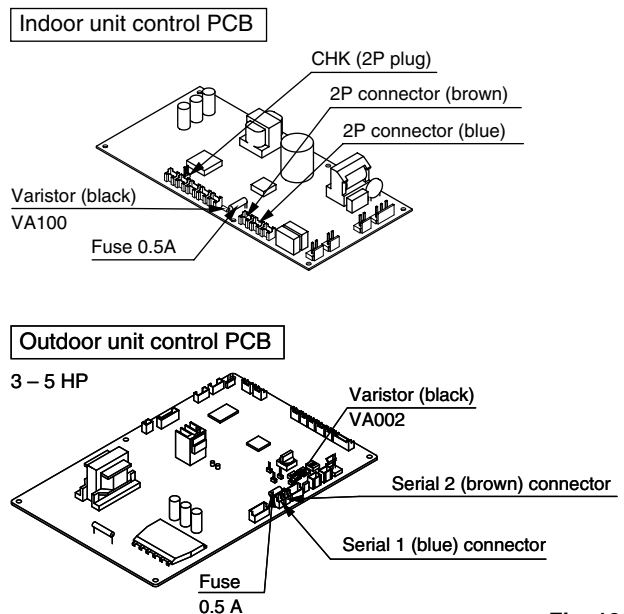

Fig. 10-15

Fig. 10-14

10-18. Test Run Procedure

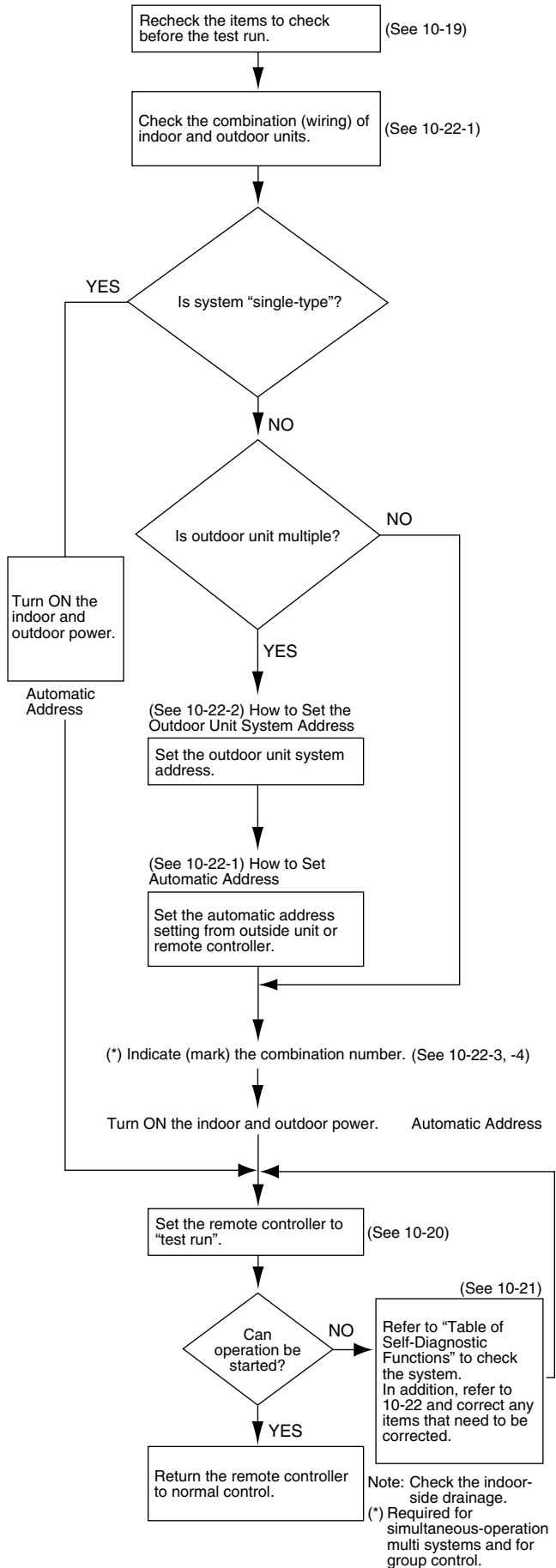





Fig. 10-16

10-19. Items to Check Before the Test Run

- (1) Turn the remote power switch ON at least 12 hours in advance in order to energize the crank case heater.
- (2) Fully open the closed valves on the liquid-tube and gas-tube sides.

10-20. Test Run Using the Remote Controller

- (1) Press and hold the remote controller  button for 4 seconds or longer. Then press the  button.
 - "TEST" appears in the LCD display during the test run.
 - Temperature control is not possible when test run mode is engaged. (This mode places a large load on the devices. Use it only when performing the test run.)
- (2) Use either Heating or Cooling mode to perform the test run.

Note: The outdoor unit will not operate for approximately 3 minutes after the power is turned ON or after it stops operating.
- (3) If normal operation is not possible, a code appears on the remote controller LCD display. Refer to "10-21. Table of Self-Diagnostic Functions and Corrections" and correct the problem.
- (4) After the test run is completed, press the  button again. Check that "TEST" disappears from the LCD display. (This remote controller includes a function that cancels test run mode after a 60-minute timer has elapsed, in order to prevent continuous test run operation.)
- (5) For the test run of an inverter outdoor unit, operate the compressors for a minimum of 10 minutes (in order to check for open phase).

* When performing a test run using a wired remote controller, operation is possible without attaching the cassette-type ceiling panel. ("P09" will not be displayed.)

10-21. Table of Self-Diagnostic Functions and Corrections (4WK, C, D Types)

Wired remote controller display	Indoor unit receiver lamp	Cause		Correction
		Group connection and simultaneous-operation multi system		
Nothing is displayed	Nothing is displayed.	<ul style="list-style-type: none"> Remote controller is not connected with indoor unit correctly. Indoor unit power is not ON. 		Connect the remote controller correctly. Turn ON the indoor unit power.
E01 displayed	Operation lamp is blinking.	<ul style="list-style-type: none"> Automatic address setting has not been completed. Inter-unit control wiring is cut or is not connected correctly. Remote controller is not connected with indoor unit correctly. 		Check the remote controller and inter-unit control wiring. Perform automatic address setting (10-22).
E02 displayed		<ul style="list-style-type: none"> Remote controller is not connected with indoor unit correctly. 		Connect the remote controller correctly.
E14 displayed		<ul style="list-style-type: none"> Remote controller communication wiring is cut or is not connected correctly. 		Check the remote controller communication wiring. Perform automatic address setting again.
E04 displayed	Standby lamp is blinking.	<ul style="list-style-type: none"> Indoor-outdoor inter-unit wiring is not connected correctly. 		Connect the wiring correctly.
E06 displayed		<ul style="list-style-type: none"> Inter-unit control wiring is cut or is not connected correctly. 		Refer to 10-22-1. Basic wiring diagram, and make the correct setting.
E15 displayed		<ul style="list-style-type: none"> Indoor unit capacity is too low. 		Check that the total capacities of the indoor and outdoor units are appropriate.
E16 displayed		<ul style="list-style-type: none"> Indoor unit capacity is too high. 		
P05 displayed	Operation lamp and Standby lamp are blinking alternately.	<ul style="list-style-type: none"> Reversed phase or open phase in the 3-phase power at one of the outdoor units in the group. Insufficient gas 		Reverse 2 phases of the outdoor unit 3-phase power and connect them correctly. Fill up the gas appropriately.
P09 displayed	Timer lamp and Standby lamp are blinking alternately.	<ul style="list-style-type: none"> Ceiling panel connector at one of the indoor units in the group is not connected correctly. 		Connect the indoor unit ceiling panel connector correctly.
P12 displayed		<ul style="list-style-type: none"> DC fan trouble at one of the indoor units in the group. 		Check whether the fan holder is loose. Check the wiring between the DC fan and the PCB.
L02 displayed	Both the Operation lamp and Standby lamp are blinking together.	<ul style="list-style-type: none"> Indoor-outdoor unit type mismatch. 		Check that the indoor and outdoor unit types are correct.
L13 displayed		<ul style="list-style-type: none"> Remote controller communication wiring is connected to the indoor unit, however it is set for individual operation. 		Perform automatic address setting (10-22).
L07 displayed		<ul style="list-style-type: none"> Check outdoor operation with separate maintenance-use remote controller. 		
L10 displayed				

10-22. Automatic Address Setting

10-22-1. Basic wiring diagram

● Link wiring

NOTE

- A terminal plug (black) is attached to each of the outdoor unit control PCBs. At only one outdoor unit, leave the terminal plug short-circuit socket on the “Yes” side. At all the other outdoor units, change the socket (from “Yes” to “No”).
- A maximum of 8 indoor units can be connected to 1 remote controller for group control.

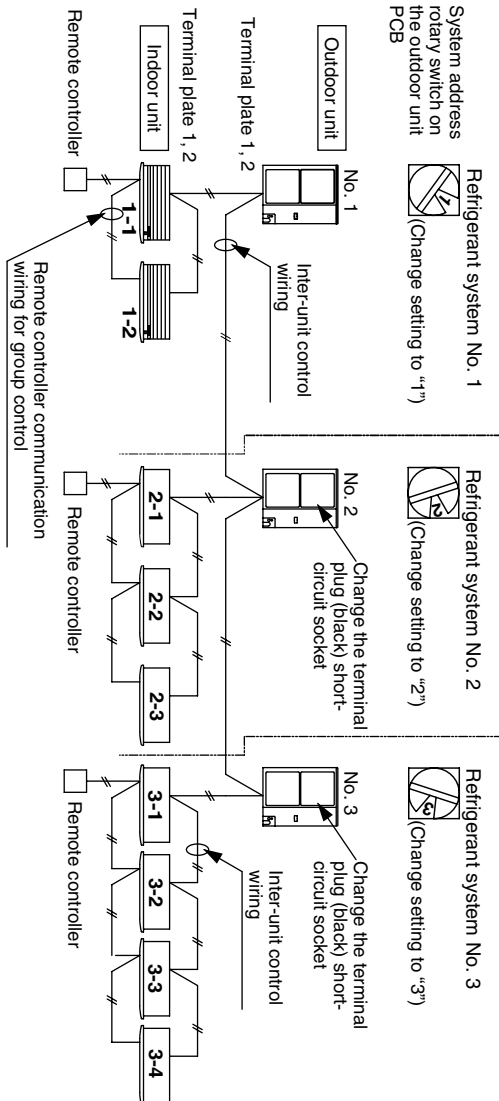

Fig. 10-17

Automatic address setting from the outdoor unit (4WK, C, D Types)

Case 1

- If the power can be turned ON separately for the indoor and outdoor units in each system, the indoor unit addresses can be set without running the compressor.
- (1) Turn on the indoor and outdoor unit power for refrigerant system 1.
Press and hold the automatic address setting button (black) for 1 second or longer at the outdoor unit where the power was turned ON.
↓
Communication for automatic address setting begins.
↓
LED 1 and 2 on the outdoor unit control PCB blink alternately, and turn OFF when address setting is completed.
↓
<Approximately 4 – 5 minutes are required.>
 - (2) Next, turn ON the power only at the indoor and outdoor units in a different system. Press the automatic address setting button (black) on the outdoor unit.
↓
LED 1 and 2 on the outdoor unit control PCB blink alternately, and turn OFF when address setting is completed.
↓
Repeat the same procedure for each system and complete automatic address setting.
 - (3) Operation using the remote controller is now possible.

Case 2

- If the power cannot be turned ON separately for the indoor and outdoor units in each system:
The compressors must be run in order to automatically set the indoor unit addresses. Therefore perform this step after completing the refrigerant tubing work.
- (1) Turn ON the power to the indoor and outdoor units in all refrigerant systems.
↓
When setting addresses in cooling mode
 - (2) Short-circuit the mode-change pin at the outdoor unit where automatic address setting will be performed. Then press the automatic address setting button (black).
↓
When setting addresses in heating mode
 - (2) Press the automatic address setting button (black) at the outdoor unit where automatic address setting will be performed.
↓
 - (3) LED 1 and 2 blink alternately. The compressors begin running in Cooling (or Heating) mode. Communication for automatic address setting begins, using the temperature changes at the indoor units.
<All indoor units are in operating status.>
↓
Address setting is completed when the compressors stop and the LED indicators turn OFF. <Approximately 15 minutes is required for 1 system.>
If address setting fails, LED 1 and 2 blink simultaneously and the alarm contents are displayed at the remote controller.
 - (4) After 1 system is completed, be sure to press the automatic address setting button (black) at the other outdoor units to complete automatic address setting in the same way for each system.
 - (5) Operation using the remote controller is now possible.

Automatic address setting using the remote controller

Case 3

- If the power can be turned ON separately for the indoor and outdoor units in each system (indoor unit addresses can be set without running the compressor):

Individual system automatic address setting: Display item code "A1".

- (1) Press the remote controller timer time button and button simultaneously. (Hold for 4 seconds or longer.)
- (2) Then press either the temperature setting or button. (Confirm that the item code is "A1".)
- (3) Use either the or button to select the outdoor unit to perform automatic address setting for. Then press the button. ("R.C.1" is displayed, and automatic address setting is performed for refrigerant system 1.)
When automatic address setting for system 1 is completed, the units return to normal stopped status.
<Approximately 4 – 5 minutes are required.>

During automatic address setting, "SETTING" blinks on the remote controller display. This display disappears when address setting is completed.

Case 4

- If the power cannot be turned ON separately for the indoor and outdoor units in each system: (The compressors must be run in order to automatically set the indoor unit addresses. Therefore perform this step after completing the refrigerant tubing work.)

All-systems automatic address setting: Display item code "AA".

- (1) Press the remote controller timer time button and button simultaneously. (Hold for 4 seconds or longer.)
- (2) Next press the button. (Automatic address setting is performed in sequence for all outdoor units from No. 1 to No. 30. When automatic address setting is completed, the units return to normal stopped status.)
<Approximately 15 minutes is required for each system.>

During automatic address setting, "SETTING" blinks on the remote controller display. This display disappears when address setting is completed.



Fig. 10-18

10-22-2. Setting outdoor unit system addresses

For the basic wiring diagram (Set the system addresses: 1, 2, 3...)

Outdoor unit control PCB 3 – 6 HP

System address rotary switch (Set to "0" at time of shipment)

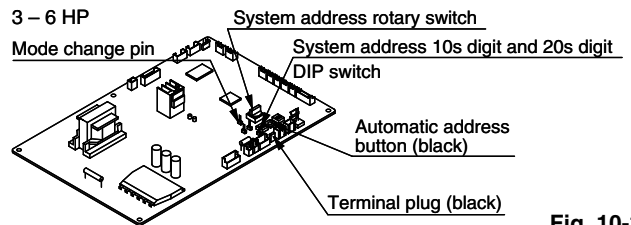
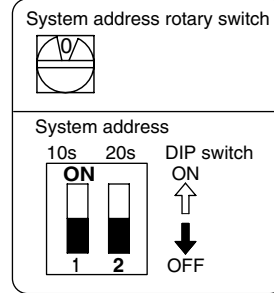

Fig. 10-19

System address No.	System address 10s digit (2P DIP switch)	System address 1s place (Rotary switch)
0 Automatic address (Setting at shipment = "0")	Both OFF 	"0" setting
1 (If outdoor unit is No. 1)	Both OFF 	"1" setting
2 (If outdoor unit is No. 2)	Both OFF 	"2" setting
11 (If outdoor unit is No. 11)	10s digit ON 	"1" setting
21 (If outdoor unit is No. 21)	20s digit ON 	"1" setting
30 (If outdoor unit is No. 30)	10s digit and 20s digit ON 	"0" setting

10-22-3. Checking indoor unit addresses

Use the remote controller to check the addresses of the indoor units. Press and hold the button and button for 4 seconds or longer (simple settings mode, "ALL" appears on the remote controller). Then press the button and select the indoor address.

(For the system addresses of the No. 1 outdoor unit, each time the button is pressed, the address changes as follows: 1-1, 1-2, ...)

The indoor unit fan operates only at the selected indoor unit. Confirm the indoor unit address. (For the system addresses of the No. 2 outdoor unit, the displayed addresses are 2-1, 2-2, ...)

Press the button again to return to the normal remote controller mode.

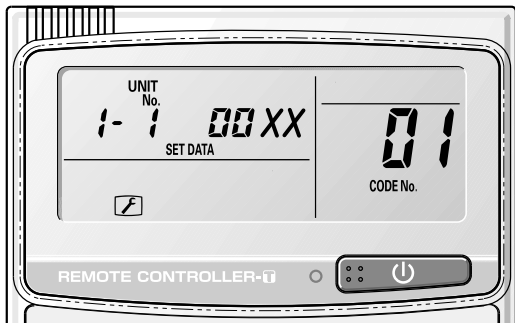

Fig. 10-20

10-22-4. Indicating (marking) the indoor and outdoor unit combination number

Indicate (mark) the number after automatic address setting is completed.

- (1) So that the combination of each indoor unit can be easily checked when multiple units are installed, ensure that the indoor and outdoor unit numbers correspond to the system address number on the outdoor unit control PCB, and use a magic marker or similar means which cannot be easily removed to indicate the numbers in an easily visible location on the indoor units (near the indoor unit nameplates).

Example: (Outdoor) 1 – (Indoor) 1, 2...
(Outdoor) 2 – (Indoor) 1, 2...

- (2) These numbers will be needed for maintenance. Be sure to indicate them.

■ HW Type (for Link Wiring)

10-23. Caution

- This unit may be used in a single-type refrigerant system where 1 outdoor unit is connected to 1 indoor unit, and also in a system where 1 outdoor unit is connected to multiple indoor units (maximum 4).
- If link wiring is used, set the outdoor unit system address to allow the combination of indoor and outdoor units to be identified. At the same time, indicate the indoor-outdoor unit combination number in a location where it can be checked easily (near the indoor unit nameplates). (This number will be required for subsequent maintenance. Refer to 10-26-3, -4.)
- Request that the customer be present when the test run is performed. At this time, explain the operation manual and have the customer perform the actual steps.
- Be sure to pass the manuals and warranty certificate to the customer.

- Check that the 220 – 240 V AC wiring is not connected to the inter-unit control wiring connector terminal. If 220 – 240 V AC is accidentally applied, the indoor or outdoor unit control PCB fuse (0.5 A for both indoor and outdoor units) will blow in order to protect the PCB. Correct the wiring connections, then disconnect the 2P connectors (indoor: blue, OC) (outdoor: blue, serial 1) that are connected to the PCB, and replace them with 2P connectors (indoor: brown, EMG) (outdoor: brown, serial 2). If operation is still not possible after changing the brown connectors, try cutting the varistor (black) (both indoor and outdoor). (Be sure to turn the power OFF before performing this work.)

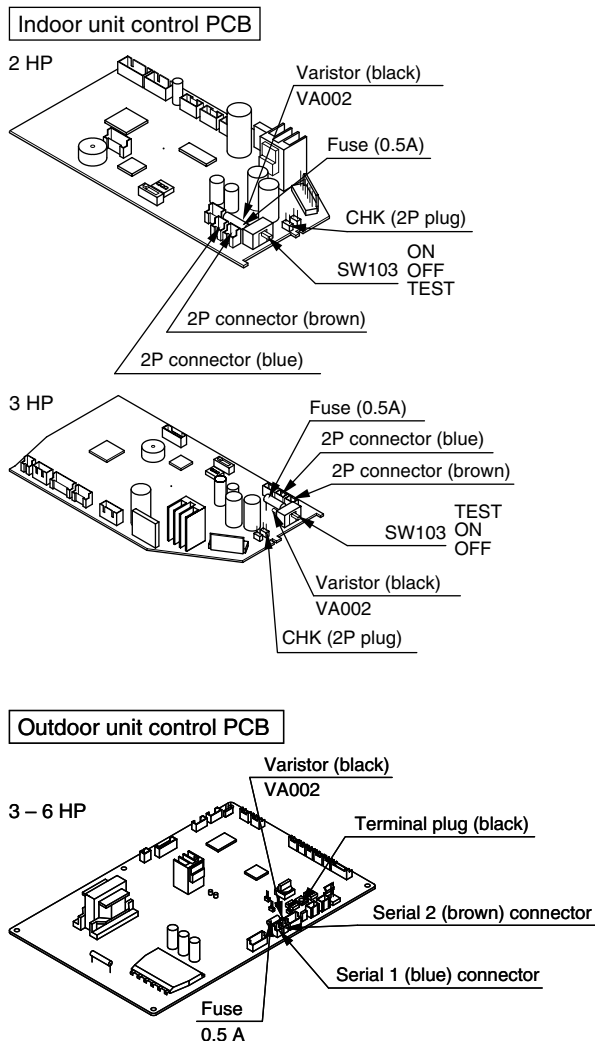

Fig. 10-21

10-24. Test Run Procedure

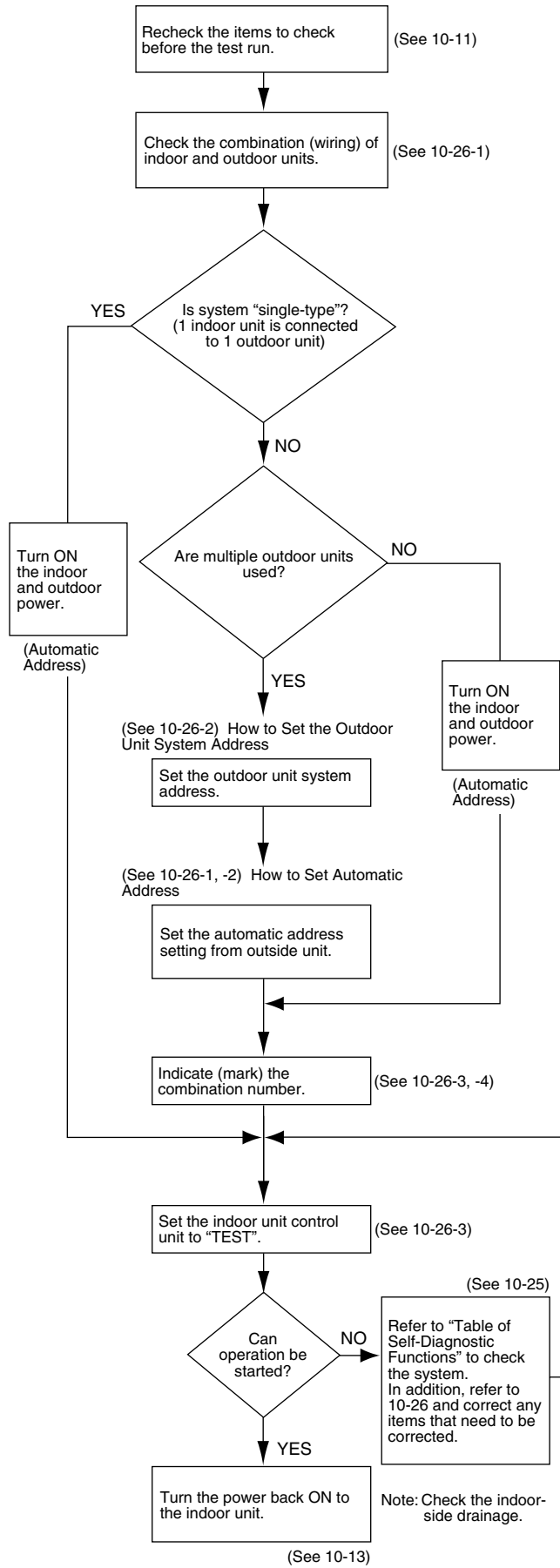

Fig. 10-22

10-25. Table of Self-Diagnostic Functions and Corrections (HW Type)

Wired remote controller display	Indoor unit receiver lamp	Cause		Correction
		Group connection and simultaneous-operation multi system		
Nothing is displayed	Nothing is displayed.	<ul style="list-style-type: none"> Remote controller is not connected with indoor unit correctly. Indoor unit power is not ON. 		Connect the remote controller correctly. Turn ON the indoor unit power.
E01 displayed	Operation lamp is blinking.	<ul style="list-style-type: none"> Automatic address setting has not been completed. Inter-unit control wiring is cut or is not connected correctly. Remote controller is not connected with indoor unit correctly. 		Check the remote controller and inter-unit control wiring. Perform automatic address setting (10-22).
E02 displayed		<ul style="list-style-type: none"> Remote controller is not connected with indoor unit correctly. 		Connect the remote controller correctly.
E14 displayed		<ul style="list-style-type: none"> Remote controller communication wiring is cut or is not connected correctly. 		Check the remote controller communication wiring. Perform automatic address setting again.
E04 displayed	Standby lamp is blinking.	<ul style="list-style-type: none"> Indoor-outdoor inter-unit wiring is not connected correctly. 		Connect the wiring correctly.
E06 displayed		<ul style="list-style-type: none"> Inter-unit control wiring is cut or is not connected correctly. 		Refer to 10-22-1. Basic wiring diagram, and make the correct setting.
E15 displayed		<ul style="list-style-type: none"> Indoor unit capacity is too low. 		Check that the total capacities of the indoor and outdoor units are appropriate.
E16 displayed		<ul style="list-style-type: none"> Indoor unit capacity is too high. 		
P05 displayed	Timer lamp and Standby lamp are blinking alternately.	<ul style="list-style-type: none"> Reversed phase or open phase in the 3-phase power at one of the outdoor units in the group. Insufficient gas 		Reverse 2 phases of the outdoor unit 3-phase power and connect them correctly. Fill up the gas appropriately.
P09 displayed	Timer lamp and Standby lamp are blinking alternately.	<ul style="list-style-type: none"> Ceiling panel connector at one of the indoor units in the group is not connected correctly. 		Connect the indoor unit ceiling panel connector correctly.
P12 displayed		<ul style="list-style-type: none"> DC fan trouble at one of the indoor units in the group. 		Check whether the fan holder is loose. Check the wiring between the DC fan and the PCB.
L02 displayed L13 displayed	Both the Operation lamp and Standby lamp are blinking together.	<ul style="list-style-type: none"> Indoor-outdoor unit type mismatch. 		Check that the indoor and outdoor unit types are correct.
L07 displayed		<ul style="list-style-type: none"> Remote controller communication wiring is connected to the indoor unit, however it is set for individual operation. 		Perform automatic address setting (10-22).
L10 displayed		<ul style="list-style-type: none"> Check outdoor operation with separate maintenance-use remote controller. 		

10-26. Automatic Address Setting

10-26-1. Basic wiring diagram

● Link wiring

NOTE

- A terminal plug (black) is attached to each of the outdoor unit control PCBs. At only 1 outdoor unit, leave the terminal plug short-circuit socket on the "Yes" side. At all the other outdoor units, change the socket (from "Yes" to "No").
- A maximum of 8 indoor units can be connected to 1 remote controller for group control.

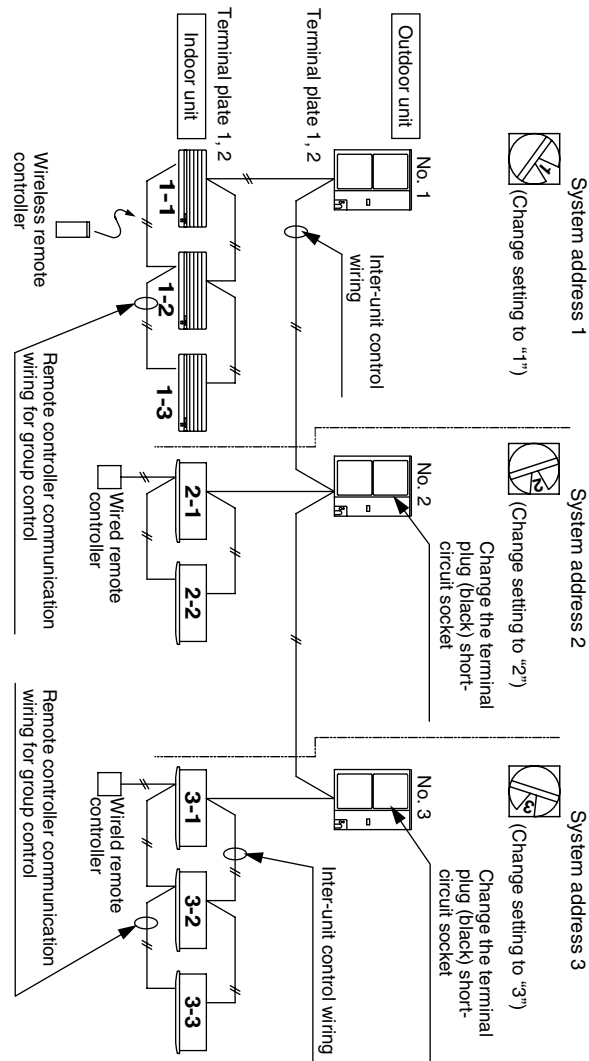

* If wall-mounted type units are used for a simultaneous-operation multi system (group control), refer to 10-16. System Control (basic wiring diagrams and wiring procedures) when wiring.

Fig. 10-23

10-26-2. Setting the outdoor unit system addresses

For basic wiring diagram (Set the system addresses: 1, 2, 3...)

Outdoor unit control PCB 3 – 6 HP

System address rotary switch
(Set to "0" at time of shipment)

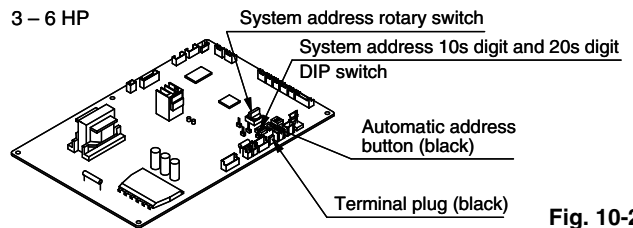
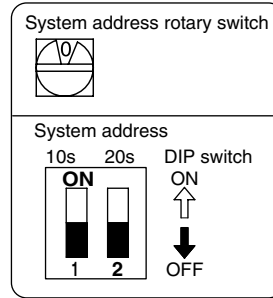

Fig. 10-24

System address No.	System address 10s digit (2P DIP switch)	System address 1s place (Rotary switch)
0 Automatic address (Setting at shipment = "0")	Both OFF ON ↑ OFF ↓	"0" setting
1 (If outdoor unit is No. 1)	Both OFF ON ↑ OFF ↓	"1" setting
2 (If outdoor unit is No. 2)	Both OFF ON ↑ OFF ↓	"2" setting
11 (If outdoor unit is No. 11)	10s digit ON ON ↑ OFF ↓	"1" setting
21 (If outdoor unit is No. 21)	20s digit ON ON ↑ OFF ↓	"1" setting
30 (If outdoor unit is No. 30)	10s digit and 20s digit ON ON ↑ OFF ↓	"0" setting

Case 1

- If the power can be turned ON separately for the indoor and outdoor units in each system:
(The indoor unit addresses can be set without running the compressor.)

Automatic address setting from the outdoor unit (K type)

- (1) Turn on the indoor and outdoor unit power for refrigerant system 1.
Press and hold the automatic address setting button (black) for 1 second or longer at the outdoor unit where the power was turned ON.
The compressor operates when the power is turned ON at a different outdoor unit.

↓
Communication for automatic address setting begins.

↓
LED 1 and 2 on the outdoor unit control PCB blink alternately, and turn OFF when address setting is completed.

↓ <Approximately 4 – 5 minutes are required.>

- (2) Next, turn ON the power only at the indoor and outdoor units in a different system. Press the automatic address setting button (black) on the outdoor unit.

↓
LED 1 and 2 on the outdoor unit control PCB blink alternately, and turn OFF when address setting is completed.

↓
Repeat the same procedure for each system and complete automatic address setting.

- (3) Operation using the remote controller is now possible.

Case 2

- If the power cannot be turned ON separately for the indoor and outdoor units in each system:
The compressors must be run in order to automatically set the indoor unit addresses. Therefore perform this step after completing the refrigerant tubing work.

- (1) Turn ON the power to the indoor and outdoor units in all refrigerant systems.

↓
When setting addresses in cooling mode

- (2) Short-circuit the mode-change pin at the outdoor unit where automatic address setting will be performed. Then press the automatic address setting button (black).

↓
When setting addresses in heating mode

- (2) Press the automatic address setting button (black) at the outdoor unit where automatic address setting will be performed.

- (3) LED 1 and 2 blink alternately. The compressors begin running in cool (or heat) mode. Communication for automatic address setting begins, using the temperature changes at the indoor units.

↓
Address setting is completed when the compressors stop and the LED indicators turn OFF. <Approximately 15 minutes is required for 1 system.>

↓
If address setting fails, LED 1 and 2 blink simultaneously and the alarm contents are displayed at the remote controller.

- (4) After 1 system is completed, be sure to press the automatic address setting button (black) at the other outdoor units to complete automatic address setting in the same way for each system.
- (5) Operation using the remote controller is now possible.

10-26-3. Checking indoor unit addresses

Use the remote controller to check the addresses of the indoor units. Press and hold the button and button for 4 seconds or longer (simple settings mode, "ALL" appears on the remote controller). Then press the button and select the indoor address.

(For the system addresses of the No. 1 outdoor unit, each time the button is pressed, the address changes as follows: 1-1, 1-2, ...)
The indoor unit fan operates only at the selected indoor unit.

Confirm the indoor unit address. (For the system addresses of the No. 2 outdoor unit, the displayed addresses are 2-1, 2-2, ...)

Press the button again to return to the normal remote controller mode.

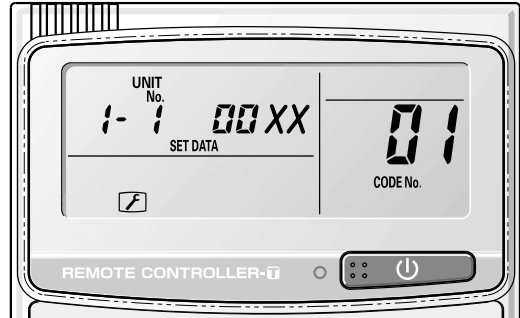

Fig. 10-25

10-26-4. Indicating (marking) the indoor and outdoor unit combination number

Indicate (mark) the number after automatic address setting is completed.

- (1) So that the combination of each indoor unit can be easily checked when multiple units are installed, ensure that the indoor and outdoor unit numbers correspond to the system address number on the outdoor unit control PCB, and use a magic marker or similar means which cannot be easily removed to indicate the numbers in an easily visible location on the indoor units (near the indoor unit nameplates).

Example: (Outdoor) 1 – (Indoor) 1, 2...
(Outdoor) 2 – (Indoor) 1, 2...

- (2) These numbers will be needed for maintenance. Be sure to indicate them.

10-26-5. Setting a wired remote controller as a sub remote controller

Change the remote controller address connected on the reverse side of the remote controller switch PCB from the Main position to the Sub position.

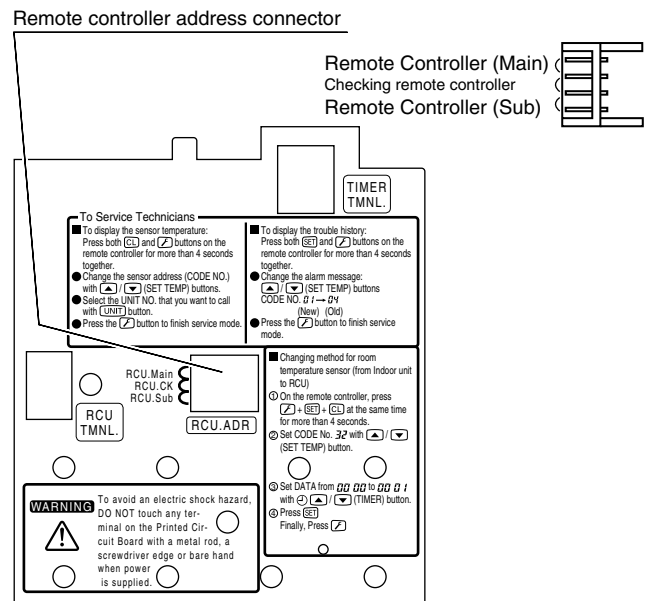

Fig. 10-26

Installing the Remote Controller

- If the remote controller is to be installed onto a wall or other surface for use, first place the remote controller in the location where it will be installed and press ON/OFF . Confirm that the “signal-received” sound occurs at the indoor unit and that the A/C begins operating.

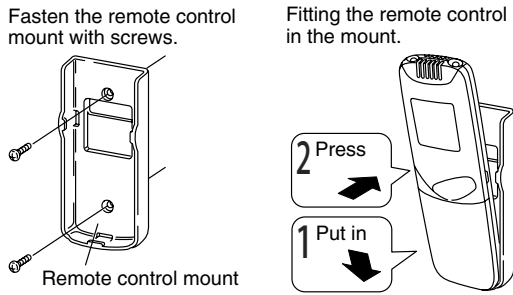

Fig. 10-27

● Installing the batteries

- (1) Press on both sides of the remote controller cover and slide it downward to remove it.
- (2) Insert 2 AAA alkaline batteries. (Pay attention to the + and – directions.)
- (3) Gently insert one end of an unfolded paper clip (or a similar object that can fit) into the Reset hole and press the reset button inside the hole and then put the cover back on.

To remove the remote controller, pull it toward you.

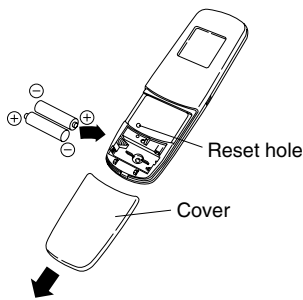

Fig. 10-28

Precautions for remote controller installation

- Before mounting the remote controller on the wall, place the unit at the mounting position, then turn on any fluorescent lamps, press the ON/OFF button, and check that the air conditioner operates correctly.

When using the remote controller to detect the room temperature, observe the following precautions during installation:

- Avoid locations where the remote controller will be exposed to the direct path of air blown from the air conditioner.
- Avoid locations where the remote controller will be exposed to direct sunlight.
- Avoid locations where the remote controller will be exposed to direct heat sources.

10-27. Caution for Pump Down

Pump down means refrigerant gas in the system is returned to the outdoor unit. Pump down is used when the unit is to be moved, or before servicing the refrigerant circuit.



- This outdoor unit cannot collect more than the rated refrigerant amount as shown by the nameplate on the back.
- If the amount of refrigerant is more than that recommended, do not conduct a pump down. In this case use another refrigerant collecting system.

Important Information Concerning Pump Down

Observe the following items when using pump down operation to recover the refrigerant.

- (1) If the length of inter-unit tubing exceeds 30 m, pump down cannot be used to recover the refrigerant. (The overload protection device may be activated.) In that case, use refrigerant recovery equipment to recover the refrigerant.
- (2) Press and hold the “Refrigerant recovery” button on the outdoor unit PCB for 1 second or longer.
 - During refrigerant recovery, LED 1 blinks and LED 2 is lit.
 - Close the liquid-side valve during refrigerant recovery.

If the unit is operated for 10 minutes or longer with the liquid-side valve open, operation will be stopped, although no alarm will be displayed on the remote controller. If this occurs, close the valve and restart operation.
- (3) When the valve service port pressure is approximately 0.1 MPa, press the S005 (Refrigerant recovery) button again to end refrigerant recovery.
 - In order to protect the compressor, do not continue operating to generate a negative pressure in the inter-unit tubing.

3 – 6 HP

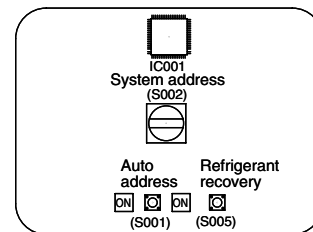

The S005 (Refrigerant recovery) button is located at the bottom right of the outdoor unit PCB, as shown in the figure above.

11. HOW TO INSTALL WIRELESS REMOTE CONTROLLER RECEIVER

NOTE

Refer to the Instruction Manual attached to the Optional Wireless Remote Controller Receiver.

12. MARKINGS FOR DIRECTIVE 97/23/EC (PED)

Rating nameplate figure

Airwell		CE	
AIR CONDITIONER		A: Model Name Various	
SOURCE: B:	V PH	Various	Hz
MAX ELECTRIC INPUT: C:	kW	A	Various
TIME DELAY FUSE MAX SIZE: D:	A	Various	
UNIT PROTECTION: IPX4			
Operating Spec. Area Various (Not for the PED)			
DESIGN PRESSURE: HIGH SIDE E:	bar Various		
LOW SIDE F:	bar Various		
REFRIGERANT: R410A	G:	kg (lbs.)	Various
		kg (lbs.)	
NET WEIGHT: Various (Not for the PED)		kg (lbs.)	
SERIAL NO.:	Various		
PROD. DATE:	DD-MM-YY		
CONTIENE REFRIGERANTE R410A			
			Made in Japan

Tabulation of Various data

A	OU-PSINV-25HR	OU-PSINV-36HR	OU-PSINV-48HR	OU-PSINV-60H
B	220 - 240 V ~ 50 / 60 Hz			
C	3.04 kW, 16.5 A	3.42 kW, 18.5 A	4.25 kW, 21.0 A	5.27 kW, 27.0 A
D	25 A		35 A	
E	41.5 bar			
F	22.1 bar			
G	1.9 kg	2.8 kg	3.6 kg	

13. APPENDIX

13-1. 4-Way Air Discharge Semi-Concealed Type (4WK Type)

■ Name of Parts (Indoor Unit)

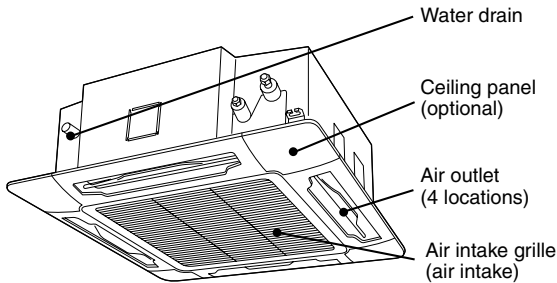

■ Care and Cleaning

⚠ WARNING

- For safety, be sure to turn the air conditioner off and also to disconnect the power before cleaning.
- Do not pour water on the indoor unit to clean it. This will damage the internal components and cause an electric shock hazard.

Air intake and outlet side (Indoor unit)

Clean the air intake and outlet side of the indoor unit with a vacuum cleaner brush, or wipe them with a clean, soft cloth. If these parts are stained, use a clean cloth moistened with water. When cleaning the air outlet side, be careful not to force the vanes out of place.

⚠ CAUTION

- Never use solvents or harsh chemicals when cleaning the indoor unit. Do not wipe plastic parts using very hot water.
- Some metal edges and the fins are sharp and may cause injury if handled improperly; be especially careful when you clean these parts.
- The internal coil and other components must be cleaned regularly. Consult your dealer or service center.

Air filter

The air filter collects dust and other particles from the air and should be cleaned at regular intervals as indicated in the table below or when the filter indication (■) on the display of the remote control unit (wired type) shows that the filter needs cleaning. If the filter gets blocked, the efficiency of the air conditioner drops greatly.

Type	Period
4WK	Six months

NOTE

The frequency with which the filter should be cleaned depends on the environment in which the unit is used.

<How to clean the filter>

1. Remove the air filter from the air intake grille.
2. Use a vacuum cleaner to remove light dust. If there is sticky dust on the filter, wash the filter in lukewarm, soapy water, rinse it in clean water, and dry it.

<How to remove the filter>

1. Use a screwdriver to remove the bolt screw on each side for the two latches. (Be sure to reattach the two bolt screws after cleaning.)
2. Press on the two latches of the air intake grille with your thumbs in the direction of the arrow to open the grille.
3. Open the air intake grille downward.

⚠ CAUTION

- When cleaning the air filter, never remove the safety chain. If it is necessary to remove it for servicing and maintenance inside, be sure to reinstall the safety chain securely (hook on the grille side) after the work.
- When the filter has been removed, rotating parts (such as the fan), electrically charged areas, etc. will be exposed in the unit's opening. Bear in mind the dangers that these parts and areas pose, and proceed with the work carefully.
- 4. Remove the air filter attached to the air intake grille.

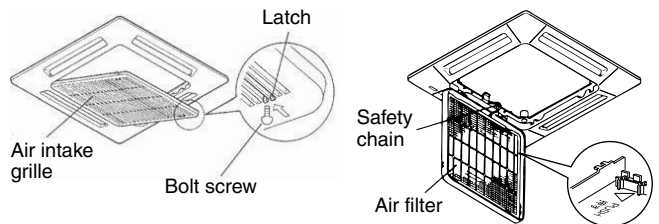

⚠ CAUTION

- Certain metal edges and the condenser fins are sharp and may cause injury if handled improperly; special care should be taken when you clean these parts.
- Periodically check the outdoor unit to see if the air outlet or air intake is clogged with dirt or soot.
- The internal coil and other components must also be cleaned periodically. Consult your dealer or service center.

Care: After a prolonged idle period

Check the indoor and outdoor unit air intakes and outlets for blockage; if there is a blockage, remove it.

Care: Before a prolonged idle period

- Operate the fan for half a day to dry out the inside.
- Disconnect the power supply and also turn off the circuit breaker.
- Clean the air filter and replace it in its original position.
- Outdoor unit internal components must be checked and cleaned periodically. Contact your local dealer for this service.

■ Troubleshooting

If your air conditioner does not work properly, first check the following points before requesting service. If it still does not work properly, contact your dealer or a service center.

Trouble	Possible Cause	Remedy
Air conditioner does not run at all	<ol style="list-style-type: none"> 1. Power failure. 2. Leakage circuit breaker has tripped. 3. Line voltage is too low. 4. Operation button is turned off. 5. The wired remote control unit or heat pump is malfunctioning. (The inspection mark  and the letters E, F, H, L, P in combination with numbers appear on the LCD of the wired remote control unit.) 	<ol style="list-style-type: none"> 1. After a power outage, press ON/OFF operation button on the wired remote control unit. 2. Contact service center. 3. Consult your electrician or dealer. 4. Press the button again. 5. Consult your dealer.
Compressor runs but soon stops	<ol style="list-style-type: none"> 1. Obstruction in front of condenser coil 	<ol style="list-style-type: none"> 1. Remove obstruction
Poor cooling (or heating) performance	<ol style="list-style-type: none"> 1. Dirty or clogged air filter. 2. Heat source or many people in room. 3. Doors and/or windows are open. 4. Obstacle near air intake or air discharge port. 5. Thermostat is set too high for cooling (or too low for heating). 6. (Defrosting system does not work.) 	<ol style="list-style-type: none"> 1. Clean air filter to improve the airflow. 2. Eliminate heat source if possible. 3. Shut them to keep the heat (or cold) out. 4. Remove it to ensure good airflow. 5. Set the temperature lower (or higher). 6. (Consult your dealer.)

■ Tips for Energy Saving

Avoid

- Do not block the air intake and outlet of the unit. If either is obstructed, the unit will not work well, and may be damaged.
- Do not let direct sunlight into the room. Use sunshades, blinds or curtains. If the walls and ceiling of the room are warmed by the sun, it will take longer to cool the room.

Do

- Always try to keep the air filter clean. (Refer to "Care and Cleaning".) A clogged filter will impair the performance of the unit.
- To prevent conditioned air from escaping, keep windows, doors and any other openings closed.

NOTE

Should the power fail while the unit is running

If the power supply for this unit is temporarily cut off, the unit will automatically resume operation once power is restored using the same settings before the power was cut off.

13-2. Concealed Duct Type (D Type)

■ Name of Parts (Indoor Unit)

CONCEALED DUCT

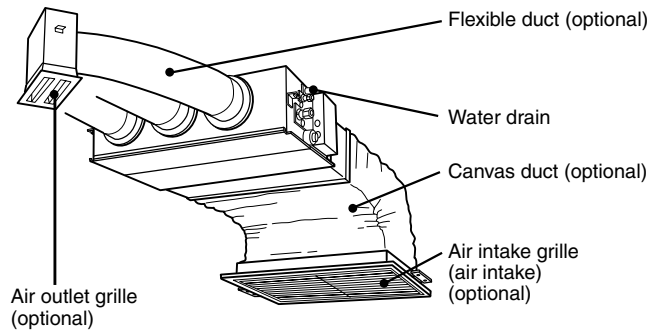

■ Care and Cleaning



WARNING

- For safety, be sure to turn the air conditioner off and also to disconnect the power before cleaning.
- Do not pour water on the indoor unit to clean it. This will damage the internal components and cause an electric shock hazard.

Air intake and outlet side (Indoor unit)

Clean the air intake and outlet side of the indoor unit with a vacuum cleaner brush, or wipe them with a clean, soft cloth.

If these parts are stained, use a clean cloth moistened with water. When cleaning the air outlet side, be careful not to force the vanes out of place.



CAUTION

- Never use solvents or harsh chemicals when cleaning the indoor unit. Do not wipe plastic parts using very hot water.
- Some metal edges and the fins are sharp and may cause injury if handled improperly; be especially careful when you clean these parts.
- The internal coil and other components must be cleaned regularly. Consult your dealer or service center.

Type	Period
D	(Depends on filter specifications)

***Concealed duct type (D):**

An air filter is not provided with this air conditioner at the time of shipment. To get clean air and to extend the service life of the air conditioner, an air filter must be installed in the air intake. For installation and cleaning the air filter, consult your dealer or service center.

NOTE

The frequency with which the filter should be cleaned depends on the environment in which the unit is used.

<How to clean the filter>

1. Remove the air filter from the air intake side.
2. Use a vacuum cleaner to remove light dust. If there is sticky dust on the filter, wash the filter in lukewarm, soapy water, rinse it in clean water, and dry it.

■ Troubleshooting

If your air conditioner does not work properly, first check the following points before requesting service. If it still does not work properly, contact your dealer or a service center.

Trouble	Possible Cause	Remedy
Air conditioner does not run at all	<ol style="list-style-type: none"> 1. Power failure. 2. Leakage circuit breaker has tripped. 3. Line voltage is too low. 4. Operation button is turned off. 5. The wired remote control unit or heat pump is malfunctioning. (The inspection mark  and the letters E, F, H, L, P in combination with numbers appear on the LCD of the wired remote control unit.) 	<ol style="list-style-type: none"> 1. After a power outage, press ON/OFF operation button on the wired remote control unit. 2. Contact service center. 3. Consult your electrician or dealer. 4. Press the button again. 5. Consult your dealer.
Compressor runs but soon stops	<ol style="list-style-type: none"> 1. Obstruction in front of condenser coil 	<ol style="list-style-type: none"> 1. Remove obstruction
Poor cooling (or heating) performance	<ol style="list-style-type: none"> 1. Dirty or clogged air filter. 2. Heat source or many people in room. 3. Doors and/or windows are open. 4. Obstacle near air intake or air discharge port. 5. Thermostat is set too high for cooling (or too low for heating). 6. (Defrosting system does not work.) 	<ol style="list-style-type: none"> 1. Clean air filter to improve the airflow. 2. Eliminate heat source if possible. 3. Shut them to keep the heat (or cold) out. 4. Remove it to ensure good airflow. 5. Set the temperature lower (or higher). 6. (Consult your dealer.)

■ Tips for Energy Saving

Avoid

- Do not block the air intake and outlet of the unit. If either is obstructed, the unit will not work well, and may be damaged.
- Do not let direct sunlight into the room. Use sunshades, blinds or curtains. If the walls and ceiling of the room are warmed by the sun, it will take longer to cool the room.

Do

- Always try to keep the air filter clean. (Refer to "Care and Cleaning.") A clogged filter will impair the performance of the unit.
- To prevent conditioned air from escaping, keep windows, doors and any other openings closed.

NOTE

Should the power fail while the unit is running

If the power supply for this unit is temporarily cut off, the unit will automatically resume operation once power is restored using the same settings before the power was interrupted.

13-3. Ceiling-Mounted Type (C Type)

■ Name of Parts

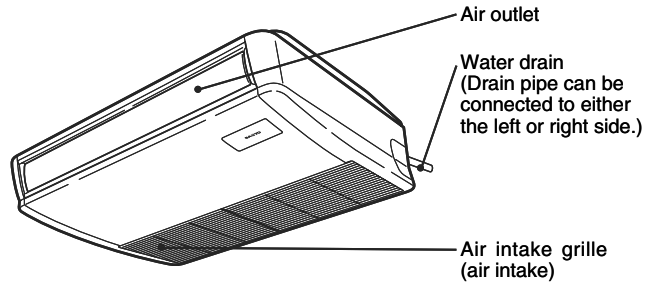

■ Care and Cleaning

! WARNING

- For safety, be sure to turn the air conditioner off and also to disconnect the power before cleaning.
- Do not pour water on the indoor unit to clean it. This will damage the internal components and cause an electric shock hazard.

Air intake and outlet side (Indoor unit)

Clean the air intake and outlet side of the indoor unit with a vacuum cleaner brush, or wipe them with a clean, soft cloth. If these parts are stained, use a clean cloth moistened with water. When cleaning the air outlet side, be careful not to force the vanes out of place.

! CAUTION

- Never use solvents or harsh chemicals when cleaning the indoor unit. Do not wipe plastic parts using very hot water.
- Some metal edges and the fins are sharp and may cause injury if handled improperly; be especially careful when you clean these parts.
- The internal coil and other components must be cleaned regularly. Consult your dealer or service center.

Air filter

The air filter collects dust and other particles from the air and should be cleaned at regular intervals as indicated in the table below or when the filter indication () on the display of the remote control unit (wired type) shows that the filter needs cleaning. If the filter gets blocked, the efficiency of the air conditioner drops greatly.

Type	Period
C	2 weeks

NOTE

The frequency with which the filter should be cleaned depends on the environment in which the unit is used.

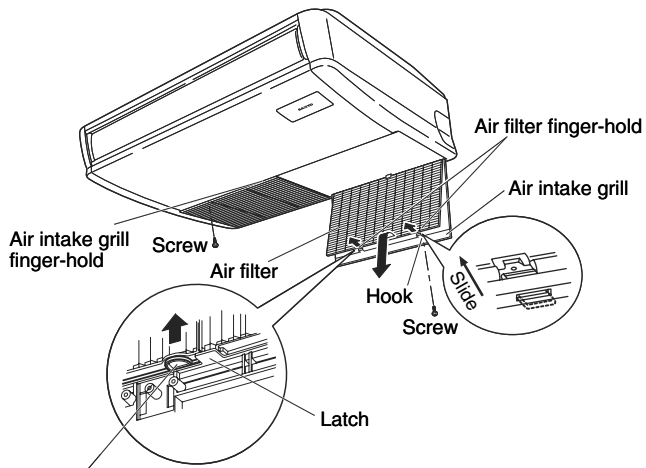

Air filter finger-hold
 * Take hold of the finger-hold on the air filter, pull it toward you.

<How to clean the filter>

1. Remove the air filter from the air intake grille.
2. Use a vacuum cleaner to remove light dust. If there is sticky dust on the filter, wash the filter in lukewarm, soapy water, rinse it in clean water, and dry it.

<How to remove the filter>

1. Take hold of the finger-hold on the air intake grille and press it to the rear, and the grille will open downward.
2. Take hold of the finger-hold on the air filter, pull it toward you.

⚠ CAUTION

- **Certain metal edges and the condenser fins are sharp and may cause injury if handled improperly; special care should be taken when you clean these parts.**
- **Periodically check the outdoor unit to see if the air outlet or air intake is clogged with dirt or soot.**
- **The internal coil and other components must also be cleaned periodically. Consult your dealer or service center.**

Care: After a prolonged idle period

Check the indoor and outdoor unit air intakes and outlets for blockage; if there is a blockage, remove it.

Care: Before a prolonged idle period

- Operate the fan for half a day to dry out the inside.
- Disconnect the power supply and also turn off the circuit breaker.
- Clean the air filter and replace it in its original position.
- Outdoor unit internal components must be checked and cleaned periodically. Contact your local dealer for this service.

■ Troubleshooting

If your air conditioner does not work properly, first check the following points before requesting service. If it still does not work properly, contact your dealer or a service center.

Trouble	Possible Cause	Remedy
Air conditioner does not run at all	1. Power failure. 2. Leakage circuit breaker has tripped. 3. Line voltage is too low. 4. Operation button is turned off. 5. The wired remote control unit or heat pump is malfunctioning. (The inspection mark Δ and the letters E, F, H, L, P in combination with numbers appear the LCD of the wired remote control unit.)	1. After a power outage, press ON/OFF operation button on the wired remote control unit. 2. Contact service center. 3. Consult your electrician or dealer. 4. Press the button again. 5. Consult your dealer.
Compressor runs but soon stops	1. Obstruction in front of condenser coil	1. Remove obstruction
Poor cooling (or heating) performance	1. Dirty or clogged air filter. 2. Heat source or many people in room. 3. Doors and/or windows are open. 4. Obstacle near air intake or air discharge port. 5. Thermostat is set too high for cooling (or too low for heating). 6. (Defrosting system does not work.)	1. Clean air filter to improve the airflow. 2. Eliminate heat source if possible. 3. Shut them to keep the heat (or cold) out. 4. Remove it to ensure good airflow. 5. Set the temperature lower (or higher). 6. (Consult your dealer.)

■ Tips for Energy Saving

Avoid

- Do not block the air intake and outlet of the unit. If either is obstructed, the unit will not work well, and may be damaged.
- Do not let direct sunlight into the room. Use sunshades, blinds or curtains. If the walls and ceiling of the room are warmed by the sun, it will take longer to cool the room.

Do

- Always try to keep the air filter clean. (Refer to "Care and Cleaning.") A clogged filter will impair the performance of the unit.
- To prevent conditioned air from escaping, keep windows, doors and any other openings closed.

NOTE

Should the power fail while the unit is running

If the power supply for this unit is temporarily cut off, the unit will automatically resume operation once power is restored using the same settings before the power was interrupted.

13-4. Wall-Mounted Type (HW Type)

■ Name of Parts

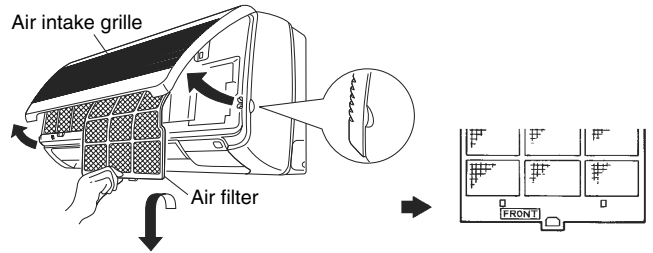
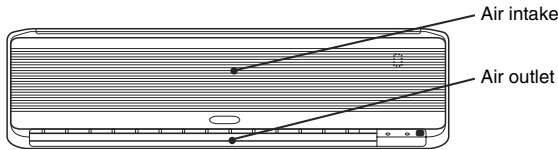

■ Care and Cleaning



- For safety, be sure to turn the air conditioner off and also to disconnect the power before cleaning.
- Do not pour water on the indoor unit to clean it. This will damage the internal components and cause an electric shock hazard.

Air intake and outlet side (Indoor unit)

Clean the air intake and outlet side of the indoor unit with a vacuum cleaner brush, or wipe them with a clean, soft cloth. If these parts are stained, use a clean cloth moistened with water. When cleaning the air outlet side, be careful not to force the vanes out of place.



- Never use solvents or harsh chemicals when cleaning the indoor unit. Do not wipe plastic parts using very hot water.
- Some metal edges and the fins are sharp and may cause injury if handled improperly; be especially careful when you clean these parts.
- The internal coil and other components must be cleaned regularly. Consult your dealer or service center.

Air filter

The air filter collects dust and other particles from the air and should be cleaned at regular intervals as indicated in the table below or when the filter indication (■) on the display of the remote control unit (wired type) shows that the filter needs cleaning. If the filter gets blocked, the efficiency of the air conditioner drops greatly.

Type	Period
HW	2 weeks

NOTE

The frequency with which the filter should be cleaned depends on the environment in which the unit is used.

<How to clean the filter>

1. Remove the air filter from the air intake grille.
2. Use a vacuum cleaner to remove light dust. If there is sticky dust on the filter, wash the filter in lukewarm, soapy water, rinse it in clean water, and dry it.

<How to remove the filter>

1. Move the flap on the air outlet grille to its lowest position with the remote control unit.
2. The filter is disengaged by pushing the tab up gently. Hold the air filter by the tab at the bottom, and pull downward.

When replacing the filter, make sure that the FRONT mark is facing you.

Push it up until you hear it click back into position.



- Certain metal edges and the condenser fins are sharp and may cause injury if handled improperly; special care should be taken when you clean these parts.
- Periodically check the outdoor unit to see if the air outlet or air intake is clogged with dirt or soot.
- The internal coil and other components must also be cleaned periodically. Consult your dealer or service center.

Care: After a prolonged idle period

Check the indoor and outdoor unit air intakes and outlets for blockage; if there is a blockage, remove it.

Care: Before a prolonged idle period

- Operate the fan for half a day to dry out the inside.
- Disconnect the power supply and also turn off the circuit breaker.
- Clean the air filter and replace it in its original position.
- Outdoor unit internal components must be checked and cleaned periodically. Contact your local dealer for this service.

■ Troubleshooting

If your air conditioner does not work properly, first check the following points before requesting service. If it still does not work properly, contact your dealer or a service center.

Trouble	Possible Cause	Remedy
Air conditioner does not run at all	<ol style="list-style-type: none"> 1. Power failure. 2. Leakage circuit breaker has tripped. 3. Line voltage is too low. 4. Operation button is turned off. 5. The wired remote control unit or heat pump is malfunctioning. (The inspection mark  and the letters E, F, H, L, P in combination with numbers appear on the LCD of the wired remote control unit.) 	<ol style="list-style-type: none"> 1. After a power outage, press ON/OFF operation button on the wired remote control unit. 2. Contact service center. 3. Consult your electrician or dealer. 4. Press the button again. 5. Consult your dealer.
Compressor runs but soon stops	<ol style="list-style-type: none"> 1. Obstruction in front of condenser coil 	<ol style="list-style-type: none"> 1. Remove obstruction
Poor cooling (or heating) performance	<ol style="list-style-type: none"> 1. Dirty or clogged air filter. 2. Heat source or many people in room. 3. Doors and/or windows are open. 4. Obstacle near air intake or air discharge port. 5. Thermostat is set too high for cooling (or too low for heating). 6. (Defrosting system does not work.) 	<ol style="list-style-type: none"> 1. Clean air filter to improve the airflow. 2. Eliminate heat source if possible. 3. Shut them to keep the heat (or cold) out. 4. Remove it to ensure good airflow. 5. Set the temperature lower (or higher). 6. (Consult your dealer.)

■ Tips for Energy Saving

Avoid

- Do not block the air intake and outlet of the unit. If either is obstructed, the unit will not work well, and may be damaged.
- Do not let direct sunlight into the room. Use sunshades, blinds or curtains. If the walls and ceiling of the room are warmed by the sun, it will take longer to cool the room.

Do

- Always try to keep the air filter clean. (Refer to "Care and Cleaning.") A clogged filter will impair the performance of the unit.
- To prevent conditioned air from escaping, keep windows, doors and any other openings closed.

NOTE

Should the power fail while the unit is running

If the power supply for this unit is temporarily cut off, the unit will automatically resume operation once power is restored using the same settings before the power was interrupted

Instructions for venting fluorinated gas

EN (English)

Do not vent **R407C** into atmosphere : **R407C** is a fluorinated greenhouse gas, covered by Kyoto Protocol, with a Global Warming Potential (GWP) = **1530**

Do not vent **R410A** into atmosphere : **R410A** is a fluorinated greenhouse gas, covered by Kyoto Protocol, with a Global Warming Potential (GWP) = **1730**

IT (Italian)

Non disperdere **R407C** nell'atmosfera : **R407C** è un gas fluorinato a effetto serra, coperto dal protocollo di Kyoto, con potenziale di riscaldamento globale (GWP) = **1530**

Non disperdere **R410A** nell'atmosfera : **R410A** è un gas fluorinato a effetto serra, coperto dal protocollo di Kyoto, con potenziale di riscaldamento globale (GWP) = **1730**

FR (French)

Ne déchargez pas **R407C** dans l'atmosphère : **R407C** est un gaz fluoré à effet serre, couvert par le protocole de Kyoto, avec un potentiel de chauffage global (GWP) = **1530**

Ne déchargez pas **R410A** dans l'atmosphère : **R410A** est un gaz fluoré à effet serre, couvert par le protocole de Kyoto, avec un potentiel de chauffage global (GWP) = **1730**

DE (German)

Zerstreuen Sie **R407C** in Atmosphäre nicht : **R407C** ist ein fluoriertes Gas, abgedeckt durch Kyoto Protokoll, mit einem globalen wärmenden Potential (GWP) = **1530**

Zerstreuen Sie **R410A** in Atmosphäre nicht : **R410A** ist ein fluoriertes Gas, abgedeckt durch Kyoto Protokoll, mit einem globalen wärmenden Potential (GWP) = **1730**

ES (Spanish)

No expulsar **R407C** a la atmósfera : el **R407C** es un gas fluorado de efecto invernadero, cubierto por el protocolo de Kyoto, con potencial de calentamiento global (GWP) = **1530**

No expulsar **R410A** a la atmósfera : el **R410A** es un gas fluorado de efecto invernadero, cubierto por el protocolo de Kyoto, con potencial de calentamiento global (GWP) = **1730**

PO (Portuguese)

Não exale **R407C** na atmosfera : **R407C** é um fluorinated gás, coberto pelo protocolo de Kyoto, com um global Protencial Aquecendo-se (GWP) = **1530**

Não exale **R410A** na atmosfera : **R410A** é um fluorinated gás, coberto pelo protocolo de Kyoto, com um global Protencial Aquecendo-se (GWP) = **1730**

GR (Greek)

Μην αερίστε **R407C** στην ατμόσφαιρα: **R407C** είναι ένα φθοριωμένο θερμοκήπιο αέριο, που καλύπτεται από το πρωτόκολλο του Κιότο, με έναν σφαιρικό Δυνατότητα θέρμανσης (GWP) = **1530**

Μην αερίστε **R410A** στην ατμόσφαιρα: **R410A** είναι ένα φθοριωμένο θερμοκήπιο αέριο, που καλύπτεται από το πρωτόκολλο του Κιότο, με έναν σφαιρικό Δυνατότητα θέρμανσης (GWP) = **1730**