

# Airwell

# Service Manual

## YUD Series

---

Indoor Units			Outdoor Units
CAD024	DBD024	FAD024	YUD024
CAD030	DBD030	FAD030	YUD030
CAD036	DBD036	FAD036	YUD036
CAD036	DBD036	FAD036	YUD036T
CAD042			YUD042
	DBD048	FAD048	YUD048
	DBD060		YUD060



---

REFRIGERANT

R410A

HEAT PUMP

SM YUD 2-A.1 GB

JAN - 2012

Version:2

---

LIST OF EFFECTIVE PAGES

**Note:** Changes in the pages are indicated by a “Revision#” in the footer of each effected page (when none indicates no changes in the relevant page). All pages in the following list represent effected/ non effected pages divided by chapters.

Dates of issue for original and changed pages are:

Total number of pages in this publication is 117 consisting of the following:

Page No.	Revision No. #	Page No.	Revision No. #	Page No.	Revision No. #
----------	----------------	----------	----------------	----------	----------------

\* Zero in this column indicates an original page.

## Table of Contents

1.	INTRODUCTION .....	1-1
2.	PRODUCT DATA SHEET.....	2-1
3.	RATING CONDITIONS .....	3-1
4.	OUTLINE DIMENSIONS.....	4-1
5.	PERFORMANCE DATA .....	5-1
6.	AIRFLOW CURVES.....	6-1
7.	ELECTRICAL DATA.....	7-1
8.	WIRING DIAGRAMS .....	8-1
9.	REFRIGERATION DIAGRAMS .....	9-1
10.	TUBING CONNECTIONS .....	10-1
11.	CONTROL SYSTEM.....	11-1
12.	TROUBLESHOOTING.....	12-1
13.	EXPLODED VIEWS AND SPARE PART LISTS.....	13-1
14.	APPENDIX .....	14-1

## 1. INTRODUCTION

### 1.1 General

The YUD/VUD series DC inverter is major designed for light commercial air-conditioning needs with the DC inverter technology, this series of products provides the most comfort and energy saving.

The outdoor can match following indoors:

-Indoor Floor/Ceiling DCI: 4 sizes including 24/30/36/48kBtu/h

-Indoor Cassette DCI: 4 sizes including 24/30/36/42kBtu/h

-Indoor Ducted DCI:5 sizes including 24/30/36/48/60kBtu/h

The outdoor unit has two options of 1 phase/3 phases:

1 Phase: 3 sizes including 24/30/36kBtu/h

3 Phase:4 sizes including 36/42/48/60kBtu/h

### 1.2 Main Features

- DCI R410A models
- Auto mode.
- Cooling
- Heating
- Dehumidification
- Sleep mode
- ON/OFF timer
- Auto swing (cassette and floor ceiling)
- 4-dimension swing(cassette only )
- Intelligent deicing
- Memory from power failure
- Cold air prevention in heating
- Self diagnostic (Error indications) for ease of maintenance
- Outdoor -15 C for cooling

### 1.3 Indoor Unit

The CAD indoor unit is ceiling mounted, the FAD indoor unit is ceiling or floor mounted, the DBD indoor unit is a low silhouette ducted unit and can be easily fitted to many types of residential and commercial applications.

It includes:

- Coil with hydrophilic aluminum fins.
- Motorized flaps (step motors) for CAD and FAD
- Advanced electronic control box assembly

### 1.4 Filtration

The series presents air filters:

- Easily accessible, and re-usable pre-filters (mesh)

### 1.5 Control

The microprocessor indoor controller, and an infrared remote control and wired controller, supplied as standard, provide complete operating function and programming. For further details please refer to the Operation Manual, Appendix A.

## 1.6 Outdoor Unit

The outdoor units can be installed as floor or wall mounted units by using a wall supporting bracket. The metal sheets are protected by anti- corrosion paint work allowing long life resistance. All outdoor units are pre-charged. For further information please refer to the Product Data Sheet, Chapter 2.

It includes :

- Compressor mounted in a soundproofed compartment :
- Axial fan.
- Outdoor coil with hydrophilic louver fins for RC units.
- Outlet air fan grill.
- Service valves" flare" type connection.

## 1.7 Tubing Connections

Flare type interconnecting tubing to be produced on site.  
For further details please refer to the Installation Manual, Chapter 10.

## 1.8 Accessories

### RCW3 Wall Mounted Remote Control

The RCW3 remote control is mounted on the wall, and controls the unit either as an infrared remote control or as a wired controller. The wired controller can control up to 10 indoor units with the same program settings and adjustment.  
For further details please refer to the Technical Service Manual.

## 1.9 Inbox Documentation

Each unit is supplied with its own installation and operation manuals.

1.10 Matching Table

OUTDOOR UNITS	INDOOR UNITS					
	AWSI-DBD024-N11	AWSI-DBD030-N11	AWSI-DBD036-N11		AWSI-DBD048-N11	AWSI-DBD060-N11
	AWSI-CAD024-N11	AWSI-CAD030-N11	AWSI-CAD036-N11	AWSI-CAD042-N11		
	AWSI-FAD024-N11	AWSI-FAD030-N11	AWSI-FAD036-N11		AWSI-FAD048-N11	
AWAU-YUD024-H11	√					
AWAU-YUD030-H11		√				
AWAU-YUD036-H11			√			
AWAU-YUD036-H13			√			
AWAU-YUD042-H13				√		
AWAU-YUD048-H13					√	
AWAU-YUD060-H13						√

## 2. PRODUCT DATA SHEET

### 2.1 AWSI-DBD024-N11 // AWAU-YUD024-H11

Model Indoor Unit		AWSI-DBD024-N11		
Model Outdoor Unit		AWAU-YUD024-H11		
Installation Method of Pipe		Flared		
Characteristics		Units		
		Cooling	Heating	
Capacity (4)		Btu/hr	22520(6820-26270)	
		kW	6.6(2.0-7.7)	
Power input (4)		kW	2.05	
EER (Cooling) or COP(Heating) (4)		W/W	3.22	
Energy efficiency class			A	
Power supply		V	220-240	
		Ph	1	
		Hz	50	
Rated current		A	9.2	
Power factor			0.97	
Prated (IDU)		W	220	
Prated (IDU+ODU)		W	3600	
INDOOR	Fan type & quantity		Centrifugal fan-2	
	Fan speeds	H/M/L	RPM	
	Air flow (1)	H/M/L	m3/hr	
	External static pressure	Min	Pa	
	Sound power level (2)	H/M/L	dB(A)	
	Sound pressure level(3)	H/M/L	dB(A)	
	Moisture removal		l/hr	
	Condensate drain tube I.D		mm	
	Dimensions	WxHxD	mm	
	Net Weight		kg	
	Package dimensions	WxHxD	mm	
	Packaged weight		kg	
OUTDOOR	Refrigerant control		EEV	
	Compressor type, model		Twin Rotary, MITSUBISHI ELECTRIC TNB220FLHMC	
	Fan type & quantity		Axial fan-1	
	Fan speeds	H	RPM	
	Air flow	H	m3/hr	
	Sound power level	H	dB(A)	
	Sound pressure level(3)	H	dB(A)	
	Dimensions	WxHxD	mm	
	Net Weight		kg	
	Package dimensions	WxHxD	mm	
	Packaged weight		kg	
	Refrigerant type		R410A	
	Standard charge		kg(5m)	
	Additional charge		g/m	
	Connections between units	Liquid line	In.(mm)	3/8"(9.53)
		Suction line	In.(mm)	5/8"(15.88)
Max.tubing length		m.	Max. 30	
Max.height difference		m.	Max. 15	
Operation control type			Remote control	
Heating elements (Option)		kW		
Others				

(1)Airflow in ducted units; at nominal external static pressure.

(2)Sound power in ducted units is measured at air discharge.

(3)Sound pressure level measured at 1-meter distance from unit.

(4)Rating conditions in accordance to ISO 5151 and ISO 13253 (for ducted units).



## 2.2 AWSI-CAD024-N11 // AWAU-YUD024-H11

Model Indoor Unit		AWSI-CAD024-N11		
Model Outdoor Unit		AWAU-YUD024-H11		
Installation Method of Pipe		Flared		
Characteristics		Units		
Capacity (4)		Btu/hr	23880(8190-27300)	
		kW	7.0(2.4-8.0)	
Power input (4)		kW	2.18	
EER (Cooling) or COP(Heating) (4)		W/W	3.21	
Energy efficiency class			A	
Power supply		V	220-240	
		Ph	1	
		Hz	50	
Rated current		A	9.8	
Power factor			0.97	
Prated (IDU)		W	150	
Prated (IDU+ODU)		W	3600	
INDOOR	Fan type & quantity		Centrifugal fan -1	
	Fan speeds	H/M/L	RPM	670/620/570
	Air flow (1)	H/M/L	m3/hr	1400/1270/1170
	External static pressure	Min	Pa	0
	Sound power level (2)	H/M/L	dB(A)	61/59/58
	Sound pressure level(3)	H/M/L	dB(A)	51/49/48
	Moisture removal		l/hr	2.5
	Condensate drain tube I.D		mm	32
	Dimensions	WxHxD	mm	840×240×840
	Net Weight		kg	28
	Package dimensions	WxHxD	mm	960×310×960
	Packaged weight		kg	36
OUTDOOR	Refrigerant control		EEV	
	Compressor type, model		Twin Rotary, MITSUBISHI ELECTRIC TNB220FLHMC	
	Fan type & quantity		Axial fan-1	
	Fan speeds	H	RPM	840
	Air flow	H	m3/hr	4200
	Sound power level	H	dB(A)	69
	Sound pressure level(3)	H	dB(A)	59
	Dimensions	WxHxD	mm	980×790×427
	Net Weight		kg	65
	Package dimensions	WxHxD	mm	1083×855×488
	Packaged weight		kg	70
	Refrigerant type		R410A	
	Standard charge		kg(5m)	2.4
	Additional charge		g/m	60
	Connections between units	Liquid line	In.(mm)	3/8"(9.53)
		Suction line	In.(mm)	5/8"(15.88)
Max.tubing length		m.	Max. 30	
Max.height difference		m.	Max. 15	
Operation control type			Remote control	
Heating elements (Option)		kW		
Others				

- (1)Airflow in ducted units; at nominal external static pressure.
- (2)Sound power in ducted units is measured at air discharge.
- (3)Sound pressure level measured at 1-meter distance from unit.
- (4)Rating conditions in accordance to ISO 5151 and ISO 13253 (for ducted units).

## 2.3 AWSI-FAD024-N11 // AWAU-YUD024-H11

Model Indoor Unit			AWSI-FAD024-N11		
Model Outdoor Unit			AWAU-YUD024-H11		
Installation Method of Pipe			Flared		
Characteristics		Units	Cooling	Heating	
Capacity (4)	Btu/hr		22520(10240-26610)	25930(8190-29000)	
	kW		6.6(3.0-7.8)	7.6(2.4-8.5)	
Power input (4)	kW		2.05	2.2	
EER (Cooling) or COP(Heating) (4)	W/W		3.22	3.45	
Energy efficiency class			A	B	
Power supply	V		220-240		
	Ph		1		
	Hz		50		
Rated current	A		9.7	10.1	
Power factor			0.97	0.97	
Prated (IDU)	W		125		
Prated (IDU+ODU)	W		3600		
INDOOR	Fan type & quantity		Centrifugal fan-4		
	Fan speeds	H/M/L	RPM	1200/1000/880	
	Air flow (1)	H/M/L	m <sup>3</sup> /hr	1200/1000/880	
	External static pressure	Min	Pa	0	
	Sound power level (2)	H/M/L	dB(A)	62/59/56	
	Sound pressure level(3)	H/M/L	dB(A)	52/49/46	
	Moisture removal			l/hr	2.5
	Condensate drain tube I.D			mm	17
	Dimensions	WxHxD	mm	1220x700x225	
	Net Weight			kg	43
	Package dimensions	WxHxD	mm	1343x315x823	
	Packaged weight			kg	52
	OUTDOOR	Refrigerant control		EEV	
Compressor type, model		Twin Rotary, MITSUBISHI ELECTRIC TNB220FLHMC			
Fan type & quantity		Axial fan-1			
Fan speeds		H	RPM	840	
Air flow		H	m <sup>3</sup> /hr	4200	
Sound power level		H	dB(A)	69	
Sound pressure level(3)		H	dB(A)	59	
Dimensions		WxHxD	mm	980x790x427	
Net Weight				kg	65
Package dimensions		WxHxD	mm	1083×855×488	
Packaged weight				kg	70
Refrigerant type				R410A	
Standard charge		kg(5m)		2.4	
Additional charge		g/m		60	
Connections between units		Liquid line	In.(mm)	3/8"(9.53)	
	Suction line	In.(mm)	5/8"(15.88)		
	Max.tubing length	m.	Max. 30		
	Max.height difference	m.	Max. 15		
Operation control type			Remote control		
Heating elements (Option)	kW				
Others					

(1)Airflow in ducted units; at nominal external static pressure.

(2)Sound power in ducted units is measured at air discharge.

(3)Sound pressure level measured at 1-meter distance from unit.

(4)Rating conditions in accordance to ISO 5151 and ISO 13253 (for ducted units).

2.4 AWSI-DBD030-N11 // AWAU-YUD030-H11

Model Indoor Unit		AWSI-DBD030-N11		
Model Outdoor Unit		AWAU-YUD030-H11		
Installation Method of Pipe		Flared		
<b>Characteristics</b>		<b>Units</b>	<b>Cooling</b> <b>Heating</b>	
Capacity (4)		Btu/hr	26610(9210-28320)      27980(6820-31730)	
		kW	7.8(2.7-8.3)      8.2(2.0-9.3)	
Power input (4)		kW	2.6      2.4	
EER (Cooling) or COP(Heating) (4)		W/W	3.0      3.42	
Energy efficiency class			B      B	
Power supply		V	220-240	
		Ph	1	
		Hz	50	
Rated current		A	11.7      10.8	
Power factor			0.97      0.97	
Prated (IDU)		W	220	
Prated (IDU+ODU)		W	4200	
INDOOR	Fan type & quantity		Centrifugal fan-2	
	Fan speeds	H/M/L	RPM	1250/1220/1060
	Air flow (1)	H/M/L	m3/hr	1500/1400/1250
	External static pressure	Min	Pa	50(0-100)
	Sound power level (2)	H/M/L	dB(A)	57/54/52
	Sound pressure level(3)	H/M/L	dB(A)	47/44/42
	Moisture removal		l/hr	2.5
	Condensate drain tube I.D		mm	20
	Dimensions	WxHxD	mm	1270×268×530
	Net Weight		kg	40
	Package dimensions	WxHxD	mm	1345×283×594
	Packaged weight		kg	46
OUTDOOR	Refrigerant control		EEV	
	Compressor type, model		Twin Rotary, MITSUBISHI ELECTRIC TNB220FLHMC	
	Fan type & quantity		Axial fan-1	
	Fan speeds	H	RPM	780
	Air flow	H	m3/hr	4200
	Sound power level	H	dB(A)	69
	Sound pressure level(3)	H	dB(A)	59
	Dimensions	WxHxD	mm	980×790×427
	Net Weight		kg	68
	Package dimensions	WxHxD	mm	1083×855×488
	Packaged weight		kg	74
	Refrigerant type			R410A
	Standard charge		kg(5m)	2.6
	Additional charge		g/m	60
	Connections between units	Liquid line	In.(mm)	3/8"(9.53)
Suction line		In.(mm)	5/8"(15.88)	
Max.tubing length		m.	Max. 30	
Max.height difference		m.	Max. 15	
Operation control type			Remote control	
Heating elements (Option)		kW		
Others				

- (1)Airflow in ducted units; at nominal external static pressure.
- (2)Sound power in ducted units is measured at air discharge.
- (3)Sound pressure level measured at 1-meter distance from unit.
- (4)Rating conditions in accordance to ISO 5151 and ISO 13253 (for ducted units).

## 2.5 AWSI-CAD030-N11 // AWAU-YUD030-H11

Model Indoor Unit		AWSI-CAD030-N11	
Model Outdoor Unit		AWAU-YUD030-H11	
Installation Method of Pipe		Flared	
Characteristics		Units	Cooling
			Heating
Capacity (4)		Btu/hr	29340(10240-31050)
		kW	8.6(3.0-9.1)
Power input (4)		kW	2.6
EER (Cooling) or COP(Heating) (4)		W/W	3.31
Energy efficiency class			A
Power supply		V	220-240
		Ph	1
		Hz	50
Rated current		A	11.7
Power factor			0.97
Prated (IDU)		W	155
Prated (IDU+ODU)		W	4200
INDOOR	Fan type & quantity		Centrifugal fan -1
	Fan speeds	H/M/L	RPM
	Air flow (1)	H/M/L	m3/hr
	External static pressure	Min	Pa
	Sound power level (2)	H/M/L	dB(A)
	Sound pressure level(3)	H/M/L	dB(A)
	Moisture removal		l/hr
	Condensate drain tube I.D		mm
	Dimensions	WxHxD	mm
	Net Weight		kg
	Package dimensions	WxHxD	mm
	Packaged weight		kg
OUTDOOR	Refrigerant control		EEV
	Compressor type, model		Twin Rotary, MITSUBISHI ELECTRIC TNB220FLHMC
	Fan type & quantity		Axial fan-1
	Fan speeds	H	RPM
	Air flow	H	m3/hr
	Sound power level	H	dB(A)
	Sound pressure level(3)	H	dB(A)
	Dimensions	WxHxD	mm
	Net Weight		kg
	Package dimensions	WxHxD	mm
	Packaged weight		kg
	Refrigerant type		R410A
	Standard charge		kg(5m)
	Additional charge		g/m
	Connections between units	Liquid line	In.(mm)
Suction line		In.(mm)	5/8"(15.88)
Max.tubing length		m.	Max. 30
Max.height difference		m.	Max. 15
Operation control type			Remote control
Heating elements (Option)		kW	
Others			

(1)Airflow in ducted units; at nominal external static pressure.

(2)Sound power in ducted units is measured at air discharge.

(3)Sound pressure level measured at 1-meter distance from unit.

(4)Rating conditions in accordance to ISO 5151 and ISO 13253 (for ducted units).

**2.6 AWSI-FAD030-N11 // AWAU-YUD030-H11**

Model Indoor Unit		<b>AWSI-FAD030-N11</b>	
Model Outdoor Unit		<b>AWAU-YUD030-H11</b>	
Installation Method of Pipe		Flared	
<b>Characteristics</b>		<b>Units</b>	<b>Cooling</b> <b>Heating</b>
Capacity (4)		Btu/hr	29340(10580-32380)      30710(9210-33780)
		kW	8.6(3.1-9.49)      9.0(2.7-9.9)
Power input (4)		kW	2.6      2.49
EER (Cooling) or COP(Heating) (4)		W/W	3.31      3.61
Energy efficiency class			A      A
Power supply		V	220-240
		Ph	1
		Hz	50
Rated current		A	11.7      11.2
Power factor			0.97      0.97
Prated (IDU)		W	160
Prated (IDU+ODU)		W	4200
INDOOR	Fan type & quantity		Centrifugal fan-4
	Fan speeds	H/M/L	RPM      1000/920/820
	Air flow (1)	H/M/L	m3/hr      1600/1400/1200
	External static pressure	Min	Pa      0
	Sound power level (2)	H/M/L	dB(A)      60/58/56
	Sound pressure level(3)	H/M/L	dB(A)      50/48/46
	Moisture removal		l/hr      3
	Condensate drain tube I.D		mm      17
	Dimensions	WxHxD	mm      1420x700 x245
	Net Weight		kg      51
	Package dimensions	WxHxD	mm      1545x330x825
	Packaged weight		kg      58
OUTDOOR	Refrigerant control		EEV
	Compressor type, model		Twin Rotary, MITSUBISHI ELECTRIC TNB220FLHMC
	Fan type & quantity		Axial fan-1
	Fan speeds	H	RPM      840
	Air flow	H	m3/hr      4200
	Sound power level	H	dB(A)      69
	Sound pressure level(3)	H	dB(A)      59
	Dimensions	WxHxD	mm      980×790×427
	Net Weight		kg      68
	Package dimensions	WxHxD	mm      1083×855×488
	Packaged weight		kg      74
	Refrigerant type		R410A
	Standard charge		kg(5m)      2.6
	Additional charge		g/m      60
	Connections between units	Liquid line	In.(mm)
Suction line		In.(mm)	5/8"(15.88)
Max.tubing length		m.	Max. 30
Max.height difference		m.	Max. 15
Operation control type			Remote control
Heating elements (Option)		kW	
Others			

- (1)Airflow in ducted units; at nominal external static pressure.
- (2)Sound power in ducted units is measured at air discharge.
- (3)Sound pressure level measured at 1-meter distance from unit.
- (4)Rating conditions in accordance to ISO 5151 and ISO 13253 (for ducted units).

2.7 AWSI-DBD036-N11 // AWAU-YUD036-H11

Model Indoor Unit		AWSI-DBD036-N11	
Model Outdoor Unit		AWAU-YUD036-H11	
Installation Method of Pipe		Flared	
<b>Characteristics</b>		<b>Units</b>	<b>Cooling</b> <b>Heating</b>
Capacity (4)		Btu/hr	33780(11940-39240)
		kW	9.9(3.5-11.5)
Power input (4)		kW	3.3
EER (Cooling) or COP(Heating) (4)		W/W	3.00
Energy efficiency class			B      A
Power supply		V	220-240
		Ph	1
		Hz	50
Rated current		A	14.8      13.7
Power factor			0.97      0.97
Prated (IDU)		W	500
Prated (IDU+ODU)		W	4400
INDOOR	Fan type & quantity		Centrifugal fan-2
	Fan speeds	H/M/L	RPM
	Air flow (1)	H/M/L	m3/hr
	External static pressure	Min	Pa
	Sound power level (2)	H/M/L	dB(A)
	Sound pressure level(3)	H/M/L	dB(A)
	Moisture removal		l/hr
	Condensate drain tube I.D		mm
	Dimensions	WxHxD	mm
	Net Weight		kg
	Package dimensions	WxHxD	mm
	Packaged weight		kg
OUTDOOR	Refrigerant control		EEV
	Compressor type, model		Twin Rotary, MITSUBISHI ELECTRIC TNB306FPGMC
	Fan type & quantity		Axial fan-1
	Fan speeds	H	RPM
	Air flow	H	m3/hr
	Sound power level	H	dB(A)
	Sound pressure level(3)	H	dB(A)
	Dimensions	WxHxD	mm
	Net Weight		kg
	Package dimensions	WxHxD	mm
	Packaged weight		kg
	Refrigerant type		R410A
	Standard charge		kg(5m)
	Additional charge		g/m
	Connections between units	Liquid line	In.(mm)
Suction line		In.(mm)	5/8"(15.88)
Max.tubing length		m.	Max. 30
Max.height difference		m.	Max. 15
Operation control type			Remote control
Heating elements (Option)		kW	
Others			

- (1)Airflow in ducted units; at nominal external static pressure.
- (2)Sound power in ducted units is measured at air discharge.
- (3)Sound pressure level measured at 1-meter distance from unit.
- (4)Rating conditions in accordance to ISO 5151 and ISO 13253 (for ducted units).

**2.8 AWSI-CAD036-N11 // AWAU-YUD036-H11**

Model Indoor Unit		<b>AWSI-CAD036-N11</b>	
Model Outdoor Unit		<b>AWAU-YUD036-H11</b>	
Installation Method of Pipe		Flared	
<b>Characteristics</b>		<b>Units</b>	<b>Cooling</b>
			<b>Heating</b>
Capacity (4)		Btu/hr	32760(10240-39240)
		kW	9.6(3.0-11.5)
Power input (4)		kW	3.2
EER (Cooling) or COP(Heating) (4)		W/W	3.0
Energy efficiency class			B
Power supply		V	220-240
		Ph	1
		Hz	50
Rated current		A	14.3
Power factor			0.97
Prated (IDU)		W	155
Prated (IDU+ODU)		W	4400
INDOOR	Fan type & quantity		Centrifugal fan-1
	Fan speeds	H/M/L	RPM
	Air flow (1)	H/M/L	m3/hr
	External static pressure	Min	Pa
	Sound power level (2)	H/M/L	dB(A)
	Sound pressure level(3)	H/M/L	dB(A)
	Moisture removal		l/hr
	Condensate drain tube I.D		mm
	Dimensions	WxHxD	mm
	Net Weight		kg
	Package dimensions	WxHxD	mm
	Packaged weight		kg
OUTDOOR	Refrigerant control		EEV
	Compressor type, model		Twin Rotary, MITSUBISHI ELECTRIC TNB306FPGMC
	Fan type & quantity		Axial fan-1
	Fan speeds	H	RPM
	Air flow	H	m3/hr
	Sound power level	H	dB(A)
	Sound pressure level(3)	H	dB(A)
	Dimensions	WxHxD	mm
	Net Weight		kg
	Package dimensions	WxHxD	mm
	Packaged weight		kg
	Refrigerant type		R410A
	Standard charge		kg(5m)
	Additional charge		g/m
	Connections between units	Liquid line	In.(mm)
Suction line		In.(mm)	5/8"(15.88)
Max.tubing length		m.	Max. 30
Max.height difference		m.	Max. 15
Operation control type			Remote control
Heating elements (Option)		kW	
Others			

- (1)Airflow in ducted units; at nominal external static pressure.
- (2)Sound power in ducted units is measured at air discharge.
- (3)Sound pressure level measured at 1-meter distance from unit.
- (4)Rating conditions in accordance to ISO 5151 and ISO 13253 (for ducted units).

2.9 AWSI-FAD036-N11 // AWAU-YUD036-H11

Model Indoor Unit		AWSI-FAD036-N11		
Model Outdoor Unit		AWAU-YUD036-H11		
Installation Method of Pipe		Flared		
<b>Characteristics</b>		<b>Units</b>	<b>Cooling</b> <b>Heating</b>	
Capacity (4)		Btu/hr	34120(11940-44360)      37530(11940-44360)	
		kW	10.0(3.5-13.0)      11.0(3.5-13.0)	
Power input (4)		kW	3.32      3.05	
EER (Cooling) or COP(Heating) (4)		W/W	3.01      3.61	
Energy efficiency class			B      A	
Power supply		V	220-240	
		Ph	1	
		Hz	50	
Rated current		A	14.9      13.7	
Power factor			0.97      0.97	
Prated (IDU)		W	220	
Prated (IDU+ODU)		W	4400	
INDOOR	Fan type & quantity		Centrifugal fan-4	
	Fan speeds	H/M/L	RPM	1280/1140/980/920
	Air flow (1)	H/M/L	m3/hr	1700
	External static pressure	Min	Pa	0
	Sound power level (2)	H/M/L	dB(A)	62/60/58
	Sound pressure level(3)	H/M/L	dB(A)	52/50/48
	Moisture removal		l/hr	3.8
	Condensate drain tube I.D		mm	17
	Dimensions	WxHxD	mm	1420x700 x245
	Net Weight		kg	52
	Package dimensions	WxHxD	mm	1545x330x825
	Packaged weight		kg	61
OUTDOOR	Refrigerant control		EEV	
	Compressor type, model		Twin Rotary, MITSUBISHI ELECTRIC TNB306FPGMC	
	Fan type & quantity		Axial fan-1	
	Fan speeds	H	RPM	900
	Air flow	H	m3/hr	6000
	Sound power level	H	dB(A)	71
	Sound pressure level(3)	H	dB(A)	61
	Dimensions	WxHxD	mm	1107x1100x440
	Net Weight		kg	89
	Package dimensions	WxHxD	mm	1158x1235x493
	Packaged weight		kg	100
	Refrigerant type			R410A
	Standard charge		kg(5m)	3.8
	Additional charge		g/m	60
	Connections between units	Liquid line	In.(mm)	3/8"(9.53)
Suction line		In.(mm)	5/8"(15.88)	
Max.tubing length		m.	Max. 30	
Max.height difference		m.	Max. 15	
Operation control type			Remote control	
Heating elements (Option)		kW		
Others				

- (1)Airflow in ducted units; at nominal external static pressure.
- (2)Sound power in ducted units is measured at air discharge.
- (3)Sound pressure level measured at 1-meter distance from unit.
- (4)Rating conditions in accordance to ISO 5151 and ISO 13253 (for ducted units).



**2.10 AWSI-DBD036-N11 // AWAU-YUD036-H13**

Model Indoor Unit		<b>AWSI-DBD036-N11</b>		
Model Outdoor Unit		<b>AWSI-YUD036-H13</b>		
Installation Method of Pipe		Flared		
<b>Characteristics</b>		<b>Units</b>	<b>Cooling</b> <b>Heating</b>	
Capacity (4)		Btu/hr	33780(11940-39240)      37530(12970-43670)	
		kW	9.9(3.5-11.5)      11.0(3.8-12.8)	
Power input (4)		kW	3.3      3.05	
EER (Cooling) or COP(Heating) (4)		W/W	3.00      3.61	
Energy efficiency class			B      A	
Power supply		V	380-415	
		Ph	3	
		Hz	50	
Rated current		A	8.2      8.2	
Power factor			0.97      0.97	
Prated (IDU)		W	500	
Prated (IDU+ODU)		W	4400	
<b>INDOOR</b>	Fan type & quantity		Centrifugal fan-2	
	Fan speeds	H/M/L	RPM	1320/1090/910
	Air flow (1)	H/M/L	m3/hr	2300/2110/1850
	External static pressure	Min	Pa	50(0-150)
	Sound power level (2)	H/M/L	dB(A)	63/60/56
	Sound pressure level(3)	H/M/L	dB(A)	53/50/46
	Moisture removal		l/hr	3.5
	Condensate drain tube I.D		mm	26
	Dimensions	WxHxD	mm	1226x290x775
	Net Weight		kg	57
	Package dimensions	WxHxD	mm	1335x305x834
	Packaged weight		kg	67
<b>OUTDOOR</b>	Refrigerant control		EEV	
	Compressor type, model		Twin Rotary, MITSUBISHI ELECTRIC TNB306FPNMC	
	Fan type & quantity		Axial fan-1	
	Fan speeds	H	RPM	900
	Air flow	H	m3/hr	6000
	Sound power level	H	dB(A)	71
	Sound pressure level(3)	H	dB(A)	61
	Dimensions	WxHxD	mm	1107x1100x440
	Net Weight		kg	88
	Package dimensions	WxHxD	mm	1158x1235x493
	Packaged weight		kg	99
	Refrigerant type			R410A
	Standard charge		kg(5m)	3.8
	Additional charge		g/m	60
	Connections between units	Liquid line	ln.(mm)	3/8"(9.53)
Suction line		ln.(mm)	5/8"(15.88)	
Max.tubing length		m.	Max. 30	
Max.height difference		m.	Max. 15	
Operation control type			Remote control	
Heating elements (Option)		kW		
Others				

- (1)Airflow in ducted units; at nominal external static pressure.
- (2)Sound power in ducted units is measured at air discharge.
- (3)Sound pressure level measured at 1-meter distance from unit.
- (4)Rating conditions in accordance to ISO 5151 and ISO 13253 (for ducted units).

2.11 AWSI-CAD036-N11 // AWAU-YUD036-H13

Model Indoor Unit			AWSI-CAD036-N11		
Model Outdoor Unit			AWAU-YUD036-H13		
Installation Method of Pipe			Flared		
<b>Characteristics</b>		<b>Units</b>	<b>Cooling</b>	<b>Heating</b>	
Capacity (4)		Btu/hr	32760(10240-39240)	35830(11940-43670)	
		kW	9.6(3.0-11.5)	10.5(3.5-12.8)	
Power input (4)		kW	3.2	3.15	
EER (Cooling) or COP(Heating) (4)		W/W	3.00	3.33	
Energy efficiency class			B	C	
Power supply		V	380-415		
		Ph	3		
		Hz	50		
Rated current		A	8.4	7.9	
Power factor			0.97	0.97	
Prated (IDU)		W	155		
Prated (IDU+ODU)		W	4400		
INDOOR	Fan type & quantity		Centrifugal fan-1		
	Fan speeds		H/M/L	RPM	710/660/610
	Air flow (1)		H/M/L	m3/hr	1660/1570/1500
	External static pressure		Min	Pa	0
	Sound power level (2)		H/M/L	dB(A)	63/61/58
	Sound pressure level(3)		H/M/L	dB(A)	53/51/48
	Moisture removal			l/hr	3.8
	Condensate drain tube I.D			mm	32
	Dimensions		WxHxD	mm	840×320×840
	Net Weight			kg	32
	Package dimensions		WxHxD	mm	960×394×960
	Packaged weight			kg	43
OUTDOOR	Refrigerant control		EEV		
	Compressor type, model		Twin Rotary, MITSUBISHI ELECTRIC TNB306FPNMC		
	Fan type & quantity		Axial fan-1		
	Fan speeds		H	RPM	900
	Air flow		H	m3/hr	6000
	Sound power level		H	dB(A)	71
	Sound pressure level(3)		H	dB(A)	61
	Dimensions		WxHxD	mm	1107x1100x440
	Net Weight			kg	88
	Package dimensions		WxHxD	mm	1158x1235x493
	Packaged weight			kg	99
	Refrigerant type				R410A
	Standard charge			kg(5m)	3.8
	Additional charge			g/m	60
	Connections between units	Liquid line		In.(mm)	3/8"(9.53)
Suction line		In.(mm)	5/8"(15.88)		
Max.tubing length		m.	Max. 30		
Max.height difference		m.	Max. 15		
Operation control type			Remote control		
Heating elements (Option)		kW			
Others					

- (1)Airflow in ducted units; at nominal external static pressure.
- (2)Sound power in ducted units is measured at air discharge.
- (3)Sound pressure level measured at 1-meter distance from unit.
- (4)Rating conditions in accordance to ISO 5151 and ISO 13253 (for ducted units).

**2.12 AWSI-FAD036-N11 // AWAU-YUD036-H13**

Model Indoor Unit		<b>AWSI-FAD036-N11</b>	
Model Outdoor Unit		<b>AWAU-YUD036-H13</b>	
Installation Method of Pipe		Flared	
<b>Characteristics</b>		<b>Units</b>	<b>Cooling</b>
			<b>Heating</b>
Capacity (4)		Btu/hr	34120(11940-44360)
		kW	10.0(3.5-13.0)
Power input (4)		kW	3.32
EER (Cooling) or COP(Heating) (4)		W/W	3.01
Energy efficiency class			B
Power supply		V	380-415
		Ph	3
		Hz	50
Rated current		A	8.4
Power factor			0.97
Prated (IDU)		W	220
Prated (IDU+ODU)		W	4400
INDOOR	Fan type & quantity		Centrifugal fan-4
	Fan speeds	H/M/L	RPM
	Air flow (1)	H/M/L	m3/hr
	External static pressure	Min	Pa
	Sound power level (2)	H/M/L	dB(A)
	Sound pressure level(3)	H/M/L	dB(A)
	Moisture removal		l/hr
	Condensate drain tube I.D		mm
	Dimensions	WxHxD	mm
	Net Weight		kg
	Package dimensions	WxHxD	mm
	Packaged weight		kg
OUTDOOR	Refrigerant control		EEV
	Compressor type, model		Twin Rotary, MITSUBISHI ELECTRIC TNB306FPNMC
	Fan type & quantity		Axial fan-1
	Fan speeds	H	RPM
	Air flow	H	m3/hr
	Sound power level	H	dB(A)
	Sound pressure level(3)	H	dB(A)
	Dimensions	WxHxD	mm
	Net Weight		kg
	Package dimensions	WxHxD	mm
	Packaged weight		kg
	Refrigerant type		R410A
	Standard charge		kg(5m)
	Additional charge		g/m
	Connections between units	Liquid line	ln.(mm)
Suction line		ln.(mm)	5/8"(15.88)
Max.tubing length		m.	Max. 30
Max.height difference		m.	Max. 15
Operation control type			Remote control
Heating elements (Option)		kW	
Others			

- (1)Airflow in ducted units; at nominal external static pressure.
- (2)Sound power in ducted units is measured at air discharge.
- (3)Sound pressure level measured at 1-meter distance from unit.
- (4)Rating conditions in accordance to ISO 5151 and ISO 13253 (for ducted units).

## 2.13 AWSI-CAD042-N11 // AWAU-YUD042-H13

Model Indoor Unit			AWSI-CAD042-N11	
Model Outdoor Unit			AWAU-YUD042-H13	
Installation Method of Pipe			Flared	
Characteristics		Units	Cooling	Heating
Capacity (4)	Btu/hr		36850(11940-44360)	40260(12970-49470)
	kW		10.8(3.5-13.0)	11.8(3.8-14.5)
Power input (4)	kW		3.44	3.45
EER (Cooling) or COP(Heating) (4)	W/W		3.14	3.42
Energy efficiency class			B	B
Power supply	V		380-415	
	Ph		3	
	Hz		50	
Rated current	A		8.4	7.9
Power factor			0.97	0.97
Prated (IDU)	W		155	
Prated (IDU+ODU)	W		5000	
INDOOR	Fan type & quantity		Centrifugal fan-1	
	Fan speeds	H/M/L	RPM	710/660/610
	Air flow (1)	H/M/L	m <sup>3</sup> /hr	1660/1570/1500
	External static pressure	Min	Pa	0
	Sound power level (2)	H/M/L	dB(A)	63/61/58
	Sound pressure level(3)	H/M/L	dB(A)	53/51/48
	Moisture removal	l/hr		4.2
	Condensate drain tube I.D	mm		32
	Dimensions	WxHxD	mm	840×320×840
	Net Weight	kg		32
	Package dimensions	WxHxD	mm	960×394×960
	Packaged weight	kg		46
	OUTDOOR	Refrigerant control		EEV
Compressor type, model		Twin Rotary, MITSUBISHI ELECTRIC TNB306FPNMC		
Fan type & quantity		Axial fan-1		
Fan speeds		H	RPM	900
Air flow		H	m <sup>3</sup> /hr	6000
Sound power level		H	dB(A)	71
Sound pressure level(3)		H	dB(A)	61
Dimensions		WxHxD	mm	1107x1100x440
Net Weight		kg		88
Package dimensions		WxHxD	mm	1158x1235x493
Packaged weight		kg		99
Refrigerant type				R410A
Standard charge		kg(5m)		3.8
Additional charge		g/m		60
Connections between units		Liquid line	In.(mm)	3/8"(9.53)
	Suction line	In.(mm)	5/8"(15.88)	
	Max.tubing length	m.	Max. 50	
	Max.height difference	m.	Max. 30	
Operation control type			Remote control	
Heating elements (Option)	kW			
Others				

(1)Airflow in ducted units; at nominal external static pressure.

(2)Sound power in ducted units is measured at air discharge.

(3)Sound pressure level measured at 1-meter distance from unit.

(4)Rating conditions in accordance to ISO 5151 and ISO 13253 (for ducted units).

**2.14 AWSI-DBD048-N11 // AWAU-YUD048-H13**

Model Indoor Unit		<b>AWSI-DBD048-N11</b>		
Model Outdoor Unit		<b>AWSI-YUD048-H13</b>		
Installation Method of Pipe		Flared		
<b>Characteristics</b>		<b>Units</b>	<b>Cooling</b>	
			<b>Heating</b>	
Capacity (4)		Btu/hr	47770(16720-48110)	
		kW	14.0(4.9-14.1)	
Power input (4)		kW	4.37	
EER (Cooling) or COP(Heating) (4)		W/W	3.20	
Energy efficiency class			A	
Power supply		V	380-415	
		Ph	3	
		Hz	50	
Rated current		A	11.4	
Power factor			0.97	
Prated (IDU)		W	550	
Prated (IDU+ODU)		W	6200	
INDOOR	Fan type & quantity		Centrifugal fan-2	
	Fan speeds	H/M/L	RPM	
	Air flow (1)	H/M/L	m3/hr	
	External static pressure	Min	Pa	
	Sound power level (2)	H/M/L	dB(A)	
	Sound pressure level(3)	H/M/L	dB(A)	
	Moisture removal		l/hr	
	Condensate drain tube I.D		mm	
	Dimensions	WxHxD	mm	
	Net Weight		kg	
	Package dimensions	WxHxD	mm	
	Packaged weight		kg	
OUTDOOR	Refrigerant control		EEV	
	Compressor type, model		Twin Rotary, Panasonic 5VD420ZBA21	
	Fan type & quantity		Axial fan-2	
	Fan speeds	H	RPM	
	Air flow	H	m3/hr	
	Sound power level	H	dB(A)	
	Sound pressure level(3)	H	dB(A)	
	Dimensions	WxHxD	mm	
	Net Weight		kg	
	Package dimensions	WxHxD	mm	
	Packaged weight		kg	
	Refrigerant type		R410A	
	Standard charge	kg(5m)	4.3	
	Additional charge	g/m	60	
	Connections between units	Liquid line	In.(mm)	3/8"(9.53)
		Suction line	In.(mm)	5/8"(15.88)
Max.tubing length		m.	Max. 50	
Max.height difference		m.	Max.30	
Operation control type			Remote control	
Heating elements (Option)		kW		
Others				

- (1)Airflow in ducted units; at nominal external static pressure.
- (2)Sound power in ducted units is measured at air discharge.
- (3)Sound pressure level measured at 1-meter distance from unit.
- (4)Rating conditions in accordance to ISO 5151 and ISO 13253 (for ducted units).

## 2.15 AWSI-FAD048-H11 // AWAU-YUD048-H13

Model Indoor Unit		AWSI-FAD048-N11	
Model Outdoor Unit		AWAU-YUD048-H13	
Installation Method of Pipe		Flared	
Characteristics		Units	Cooling
			Heating
Capacity (4)		Btu/hr	47770(16720-48110)
		kW	14.0(4.9-14.1)
Power input (4)		kW	4.37
EER (Cooling) or COP(Heating) (4)		W/W	3.20
Energy efficiency class			A
Power supply		V	380-415
		Ph	3
		Hz	50
Rated current		A	11.1
Power factor			0.97
Prated (IDU+ODU)		W	250
Prated (IDU+ODU)		W	6200
INDOOR	Fan type & quantity		Centrifugal fan-4
	Fan speeds	H/M/L	RPM
	Air flow (1)	H/M/L	m <sup>3</sup> /hr
	External static pressure	Min	Pa
	Sound power level (2)	H/M/L	dB(A)
	Sound pressure level(3)	H/M/L	dB(A)
	Moisture removal		l/hr
	Condensate drain tube I.D		mm
	Dimensions	WxHxD	mm
	Net Weight		kg
	Package dimensions	WxHxD	mm
	Packaged weight		kg
OUTDOOR	Refrigerant control		EEV
	Compressor type, model		Twin Rotary, Panasonic 5VD420ZBA21
	Fan type & quantity		Axial fan-2
	Fan speeds	H	RPM
	Air flow	H	m <sup>3</sup> /hr
	Sound power level	H	dB(A)
	Sound pressure level(3)	H	dB(A)
	Dimensions	WxHxD	mm
	Net Weight		kg
	Package dimensions	WxHxD	mm
	Packaged weight		kg
	Refrigerant type		R410A
	Standard charge	kg(5m)	4.3
	Additional charge	g/m	60
	Connections between units	Liquid line	ln.(mm)
Suction line		ln.(mm)	5/8"(15.88)
Max.tubing length		m.	Max. 50
Max.height difference		m.	Max.30
Operation control type			Remote control
Heating elements (Option)		kW	
Others			

(1)Airflow in ducted units; at nominal external static pressure.

(2)Sound power in ducted units is measured at air discharge.

(3)Sound pressure level measured at 1-meter distance from unit.

(4)Rating conditions in accordance to ISO 5151 and ISO 13253 (for ducted units).

2.16 AWSI-DBD060-H11 // AWAU-YUD060-H13

Model Indoor Unit		AWSI-DBD060-N11	
Model Outdoor Unit		AWAU-YUD060-H13	
Installation Method of Pipe		Flared	
<b>Characteristics</b>		<b>Units</b>	<b>Cooling</b> <b>Heating</b>
Capacity (4)		Btu/hr	58000(13650-59710)      61420(17060-64150)
		kW	17.0(4.0-17.5)      18.0(5.0-18.8)
Power input (4)		kW	5.3      5.0
EER (Cooling) or COP(Heating) (4)		W/W	3.21      3.60
Energy efficiency class			A      A
Power supply		V	380-415
		Ph	3
		Hz	50
Rated current		A	13.0      12.9
Power factor			0.97      0.97
Prated (IDU)			430
Prated (IDU+ODU)		W	6900
INDOOR	Fan type & quantity		Centrifugal fan-2
	Fan speeds		H/M/L      RPM      930/830/650
	Air flow (1)		H/M/L      m3/hr      3150/2800/2200
	External static pressure		Min      Pa      50(0-150)
	Sound power level (2)		H/M/L      dB(A)      67/64/61
	Sound pressure level(3)		H/M/L      dB(A)      57/54/51
	Moisture removal		l/hr      5
	Condensate drain tube I.D		mm      30
	Dimensions		WxHxD      mm      1463x385x799
	Net Weight		kg      66
	Package dimensions		WxHxD      mm      1540x400x880
	Packaged weight		kg      76
OUTDOOR	Refrigerant control		EEV
	Compressor type, model		Twin Rotary, Panasonic 5VD420ZBA21
	Fan type & quantity		Axial fan-2
	Fan speeds		H      RPM      840
	Air flow		H      m3/hr      7200
	Sound power level		H      dB(A)      73
	Sound pressure level(3)		H      dB(A)      63
	Dimensions		WxHxD      mm      1085x1365x427
	Net Weight		kg      118
	Package dimensions		WxHxD      mm      1143x1505x478
	Packaged weight		kg      130
	Refrigerant type		R410A
	Standard charge		kg(5m)      5.5
	Additional charge		g/m      60
	Connections between units	Liquid line	
Suction line		ln.(mm)      3/4"(19.05)	
Max.tubing length		m.      Max. 50	
Max.height difference		m.      Max.30	
Operation control type			Remote control
Heating elements (Option)		kW	
Others			

- (1)Airflow in ducted units; at nominal external static pressure.
- (2)Sound power in ducted units is measured at air discharge.
- (3)Sound pressure level measured at 1-meter distance from unit.
- (4)Rating conditions in accordance to ISO 5151 and ISO 13253 (for ducted units).

### 3. RATING CONDITIONS

Rating conditions in accordance with ISO 5151 and ISO 13253 (for ducted units).

**Cooling:**

Indoor: 27°C DB 19°C WB

Outdoor: 35°C DB

**Heating:**

Indoor: 20°C DB

Outdoor: 7°C DB 6°C WB

#### 3.1 Operating Limits

##### R410A

		Indoor	Outdoor
Cooling	Upper limit	32°C DB 23°C WB	48°C DB
	Lower limit	21°C DB 15°C WB	-15°C DB
Heating	Upper limit	27°C DB	24°C DB 18°C WB
	Lower limit	10°C DB	-15°C DB
Voltage	1PH	198 – 264 V	
	3PH	360 – 440 V	



## 4. OUTLINE DIMENSIONS

### 4.1 CAD

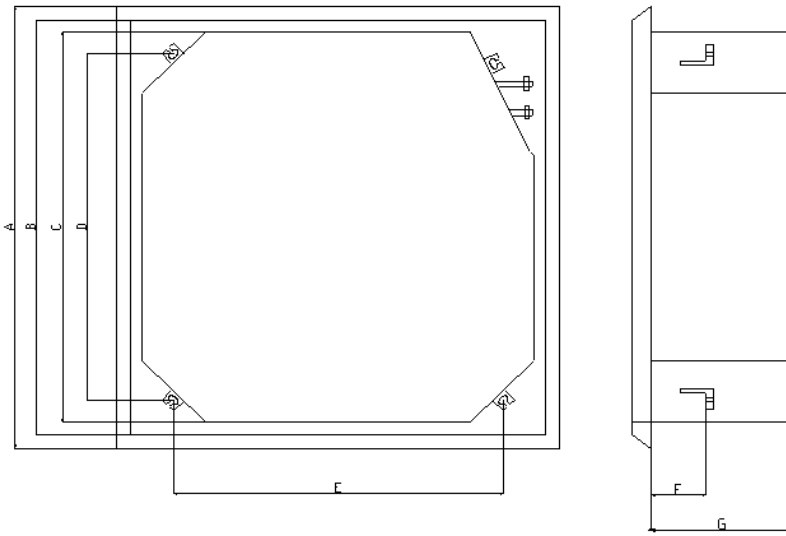

Unit:mm

Model	A	B	C	D	E	F	G
CAD024	950	890	840	780	680	160	240
CAD030/036/042	950	890	840	780	680	160	320

### 4.2 DBD 024/030/036/048

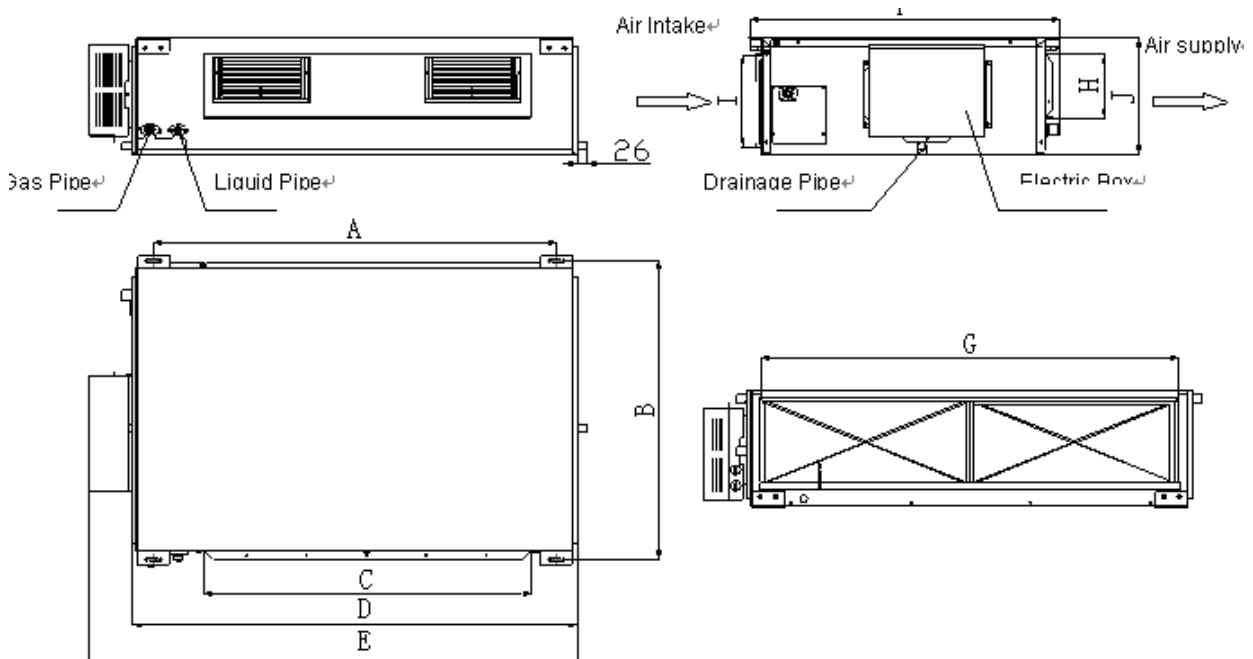

Unit: mm

	A	B	C	D	E	F	G	H	I	J
DBD024/030	1101	515	820	1159	1270	530	1002	160	235	268
DBD036	1011	748	820	1115	1226	775	979	160	231	290
DBD048	1015	788	820	1115	1226	815	979	160	261	330

4.3 DBD 060

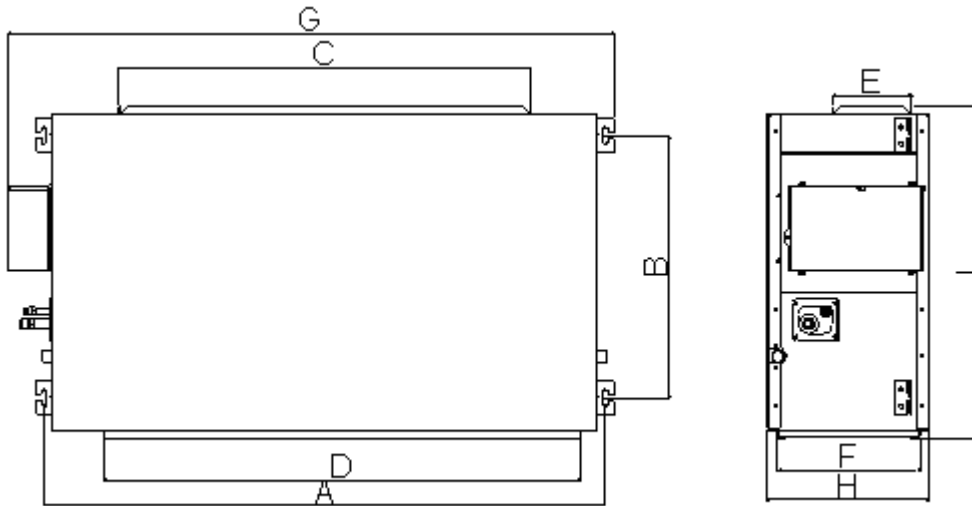

Unit: mm

Model	A	B	C	D	E	F	G	H	I
DBD060	1353	632	992	1150	192	343	1463	389	799

4.4 FAD

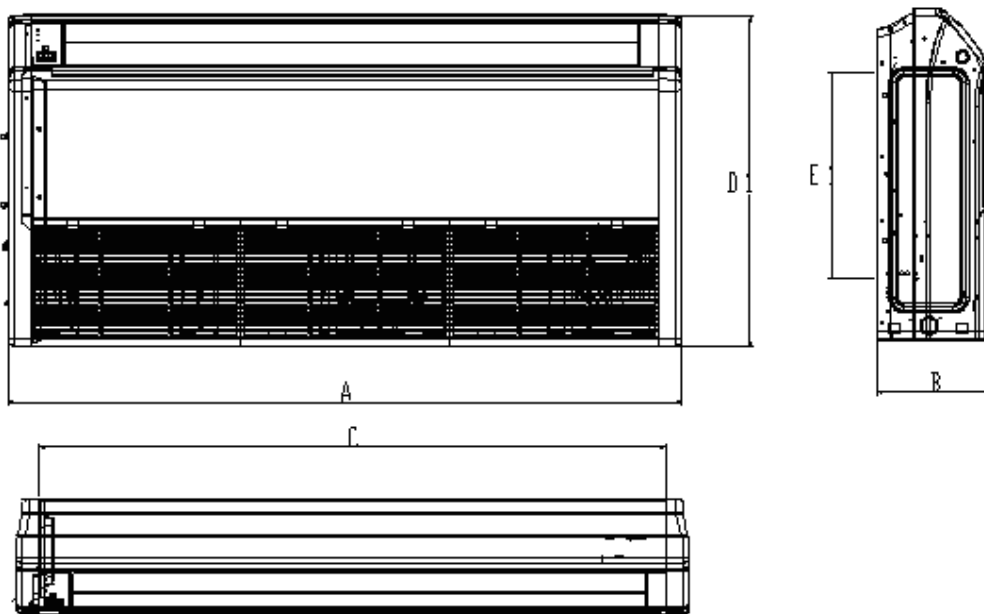

Unit: mm

Model	A	B	C	D	E
FAD024	1220	225	1158	700	280
FAD030/036	1420	245	1354	700	280
FAD048	1700	245	1634	700	280

4.5 Outdoor Unit:

4.5.1 Outdoor unit: YUD 024/030

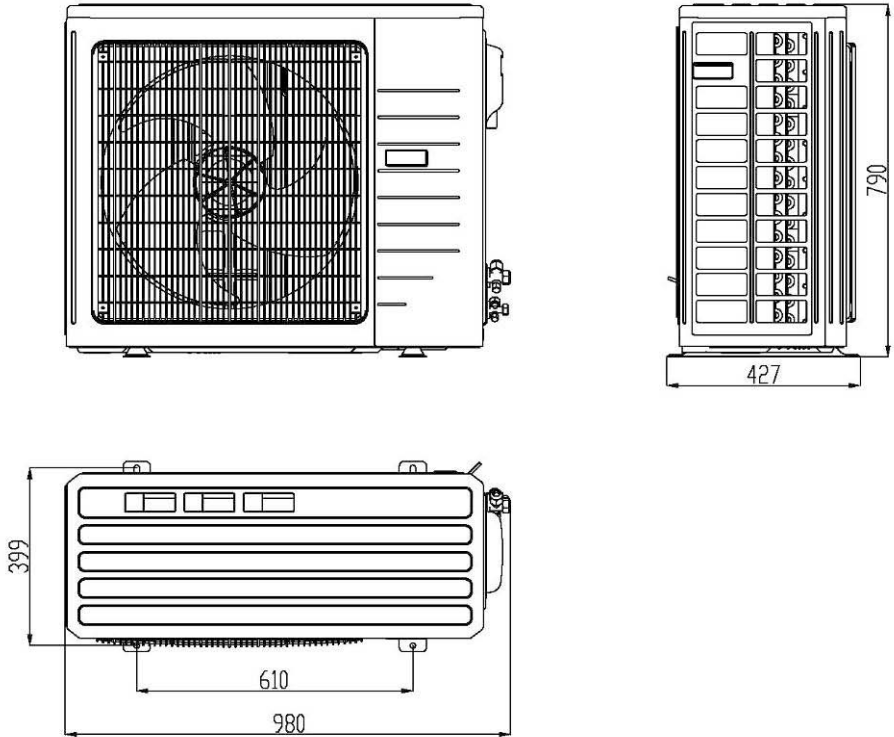

4.5.2 Outdoor unit: YUD 036/042

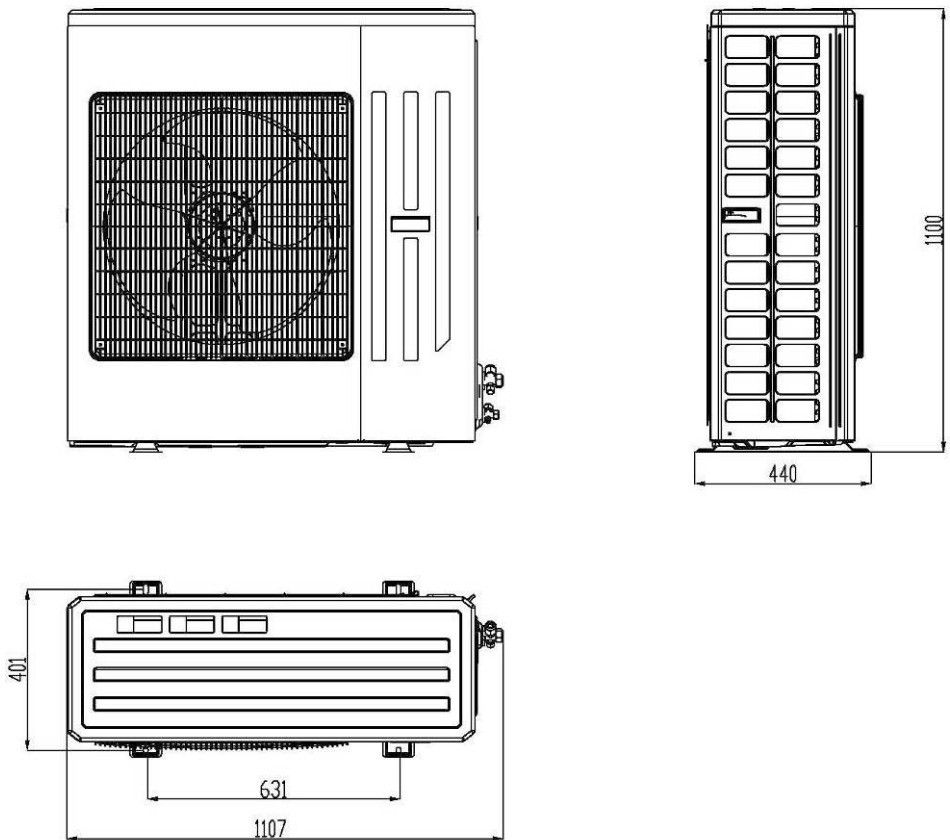

4.5.3 Outdoor unit: YUD 048/060

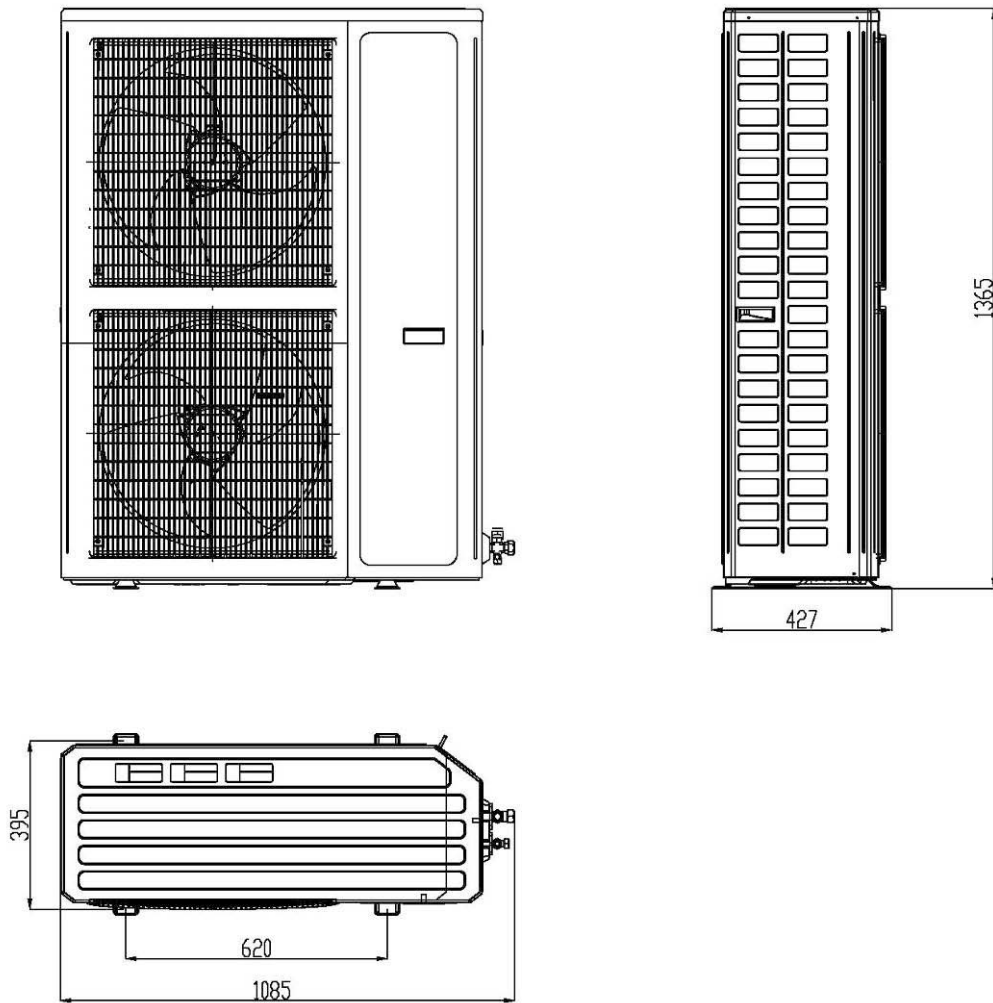

## 5. PERFORMANCE DATA

### 5.1 AWAU-YUD024-H11

#### 5.1.1 Cooling Capacity (kW)

Entering Air DB OD Coil(°C)	Data	Entering Air WB/DB ID Coil(°C)				
		15/21	17/24	19/27	21/29	23/32
20	TC	6.67	7.06	7.39	7.72	7.99
	SC	4.75	5.05	5.34	5.18	5.29
	PI	1.57	1.58	1.59	1.60	1.60
25	TC	6.40	6.86	7.26	7.59	7.85
	SC	4.22	4.52	4.78	4.69	4.82
	PI	1.70	1.71	1.73	1.74	1.74
30	TC	6.01	6.47	7.00	7.26	7.52
	SC	4.01	4.33	4.68	4.58	4.77
	PI	1.84	1.86	1.88	1.90	1.90
35	TC	5.54	6.01	6.60	6.93	7.19
	SC	3.78	4.11	4.49	4.44	4.62
	PI	1.99	2.02	2.05	2.07	2.07
40	TC	5.02	5.48	6.07	6.40	6.67
	SC	3.51	3.86	4.25	4.18	4.38
	PI	2.14	2.17	2.21	2.23	2.25
46	TC	4.36	4.82	5.41	5.74	6.01
	SC	3.19	3.54	3.98	3.91	4.09
	PI	2.35	2.39	2.43	2.46	2.48

#### LEGEND

- TC – Total Cooling Capacity, kW
- SC – Sensible Capacity, kW
- PI – Power Input, kW
- WB – Wet Bulb Temp., (°C)
- DB – Dry Bulb Temp., (°C)
- ID – Indoor
- OU – Outdoor

#### 5.1.2 Capacity Correction Factor

Cooling Capacity Ratio Vs. Outdoor Temperature

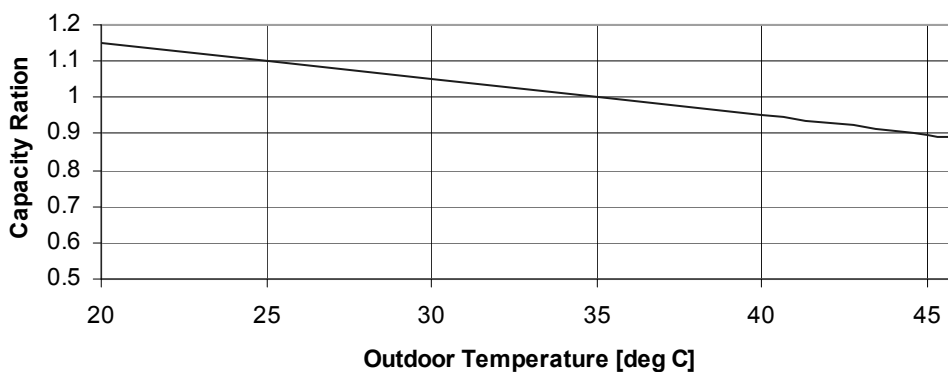

**5.1.3 Heating Capacity (kW)**

	ENTERING AIR DB ID COIL(°c)					
	15		20		25	
ENTERING WB OD COIL(°C)	TH	PI	TH	PI	TH	PI
-10	3.78	1.69	3.64	1.80	3.49	1.89
-7	4.07	1.73	3.92	1.83	3.78	1.92
-2	4.32	1.75	4.18	1.86	4.03	1.96
2	5.26	1.84	5.04	1.95	4.82	2.07
6	7.42	1.97	7.20	2.11	6.95	2.24
10	8.06	2.08	7.85	2.23	7.63	2.38
15	8.71	2.17	8.50	2.34	8.28	2.49
20	9.18	2.24	8.96	2.43	8.71	2.62

**LEGEND**

- TH – Total Heating Capacity, kW
- PI – Power Input, kW
- WB – Wet Bulb Temp., (°C)
- DB – Dry Bulb Temp., (°C)
- ID – Indoor
- OU – Outdoor

**5.1.4 Capacity Correction Factors**

**Heating Capacity Ratio Vs. Outdoor Temperature**

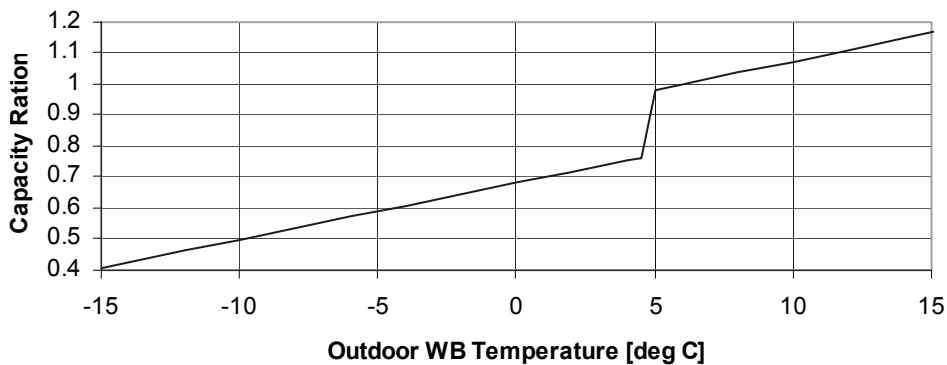

## 5.2 AWAU-YUD030-H11

### 5.2.1 Cooling Capacity (kW)

Entering Air DB OD Coil(°C)	Data	Entering Air WB/DB ID Coil(°C)				
		15/21	17/24	19/27	21/29	23/32
20	TC	7.88	8.35	8.74	9.13	9.44
	SC	5.62	5.97	6.31	6.12	6.26
	PI	1.99	2.00	2.02	2.03	2.03
25	TC	7.57	8.11	8.58	8.97	9.28
	SC	4.99	5.34	5.65	5.55	5.69
	PI	2.15	2.17	2.19	2.21	2.21
30	TC	7.10	7.64	8.27	8.58	8.89
	SC	4.74	5.11	5.52	5.41	5.63
	PI	2.33	2.36	2.39	2.41	2.42
35	TC	6.55	7.10	7.80	8.19	8.50
	SC	4.46	4.85	5.30	5.24	5.46
	PI	2.52	2.56	2.60	2.62	2.63
40	TC	5.93	6.47	7.18	7.57	7.88
	SC	4.14	4.56	5.02	4.94	5.18
	PI	2.71	2.76	2.81	2.83	2.85
46	TC	5.15	5.69	6.40	6.79	7.10
	SC	3.77	4.18	4.70	4.61	4.83
	PI	2.98	3.03	3.08	3.12	3.15

#### LEGEND

- TC – Total Cooling Capacity, kW
- SC – Sensible Capacity, kW
- PI – Power Input, kW
- WB – Wet Bulb Temp., (°C)
- DB – Dry Bulb Temp., (°C)
- ID – Indoor
- OU – Outdoor

### 5.2.2 Capacity Correction Factors

Cooling Capacity Ratio Vs. Outdoor Temperature

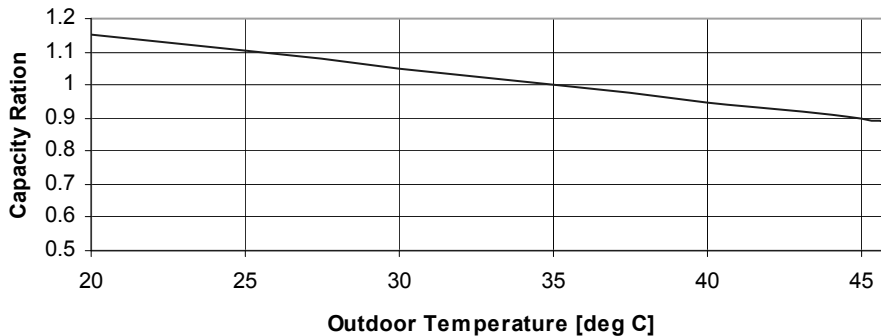

5.2.3 Heating Capacity (kW)

	ENTERING AIR DB ID COIL(°C)					
	15		20		25	
ENTERING WB OD COIL(°C)	TH	PI	TH	PI	TH	PI
-10	4.31	1.92	4.14	2.04	3.98	2.15
-7	4.63	1.97	4.47	2.08	4.31	2.19
-2	4.92	1.99	4.76	2.11	4.59	2.23
2	5.99	2.09	5.74	2.22	5.49	2.35
6	8.45	2.24	8.20	2.40	7.91	2.55
10	9.18	2.37	8.94	2.53	8.69	2.71
15	9.92	2.47	9.68	2.66	9.43	2.83
20	10.46	2.54	10.21	2.76	9.92	2.98

**LEGEND**

- TH – Total Heating Capacity, kW
- PI – Power Input, kW
- WB – Wet Bulb Temp., (°C)
- DB – Dry Bulb Temp., (°C)
- ID – Indoor
- OU – Outdoor

5.2.4 Capacity Correction Factors

Heating Capacity Ratio Vs. Outdoor Temperature

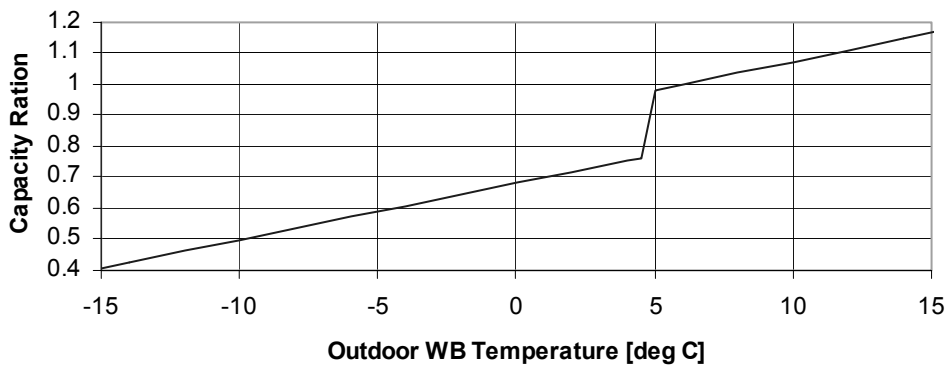



### 5.3 AWAU-YUD036-H11

#### 5.3.1 Cooling Capacity (kW)

Entering Air DB OD Coil(°C)	Data	Entering Air WB/DB ID Coil(°C)				
		15/21	17/24	19/27	21/29	23/32
20	TC	10.00	10.59	11.09	11.58	11.98
	SC	7.13	7.57	8.01	7.77	7.94
	PI	2.53	2.54	2.56	2.57	2.58
25	TC	9.60	10.30	10.89	11.39	11.78
	SC	6.33	6.78	7.17	7.04	7.22
	PI	2.73	2.76	2.78	2.80	2.81
30	TC	9.01	9.70	10.49	10.89	11.29
	SC	6.01	6.49	7.01	6.87	7.15
	PI	2.96	2.99	3.03	3.06	3.07
35	TC	8.32	9.01	9.90	10.40	10.79
	SC	5.66	6.16	6.73	6.65	6.93
	PI	3.20	3.25	3.30	3.33	3.34
40	TC	7.52	8.22	9.11	9.60	10.00
	SC	5.26	5.79	6.37	6.27	6.57
	PI	3.45	3.50	3.56	3.60	3.62
46	TC	6.53	7.23	8.12	8.61	9.01
	SC	4.78	5.30	5.97	5.86	6.13
	PI	3.78	3.84	3.91	3.96	4.00

#### LEGEND

- TC – Total Cooling Capacity, kW
- SC – Sensible Capacity, kW
- PI – Power Input, kW
- WB – Wet Bulb Temp., (°C)
- DB – Dry Bulb Temp., (°C)
- ID – Indoor
- OU – Outdoor

#### 5.3.2 Capacity Correction Factors

Cooling Capacity Ratio Vs. Outdoor Temperature

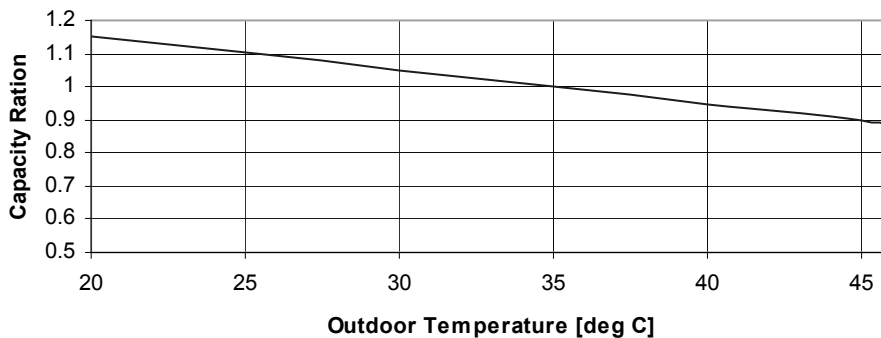

5.3.3 Heating Capacity (kW)

	ENTERING AIR DB ID COIL(°C)					
	15		20		25	
ENTERING WB OD COIL(°C)	TH	PI	TH	PI	TH	PI
-10	5.78	2.44	5.56	2.60	5.34	2.73
-7	6.22	2.50	6.00	2.64	5.78	2.78
-2	6.60	2.53	6.38	2.68	6.16	2.84
2	8.03	2.65	7.70	2.82	7.37	2.99
6	11.33	2.85	11.00	3.05	10.62	3.24
10	12.32	3.01	11.99	3.22	11.66	3.44
15	13.31	3.14	12.98	3.39	12.65	3.60
20	14.03	3.23	13.70	3.51	13.31	3.78

**LEGEND**

- TH – Total Heating Capacity, kW
- PI – Power Input, kW
- WB – Wet Bulb Temp., (°C)
- DB – Dry Bulb Temp., (°C)
- ID – Indoor
- OU – Outdoor

5.3.4 Capacity Correction Factors

Heating Capacity Ratio Vs. Outdoor Temperature

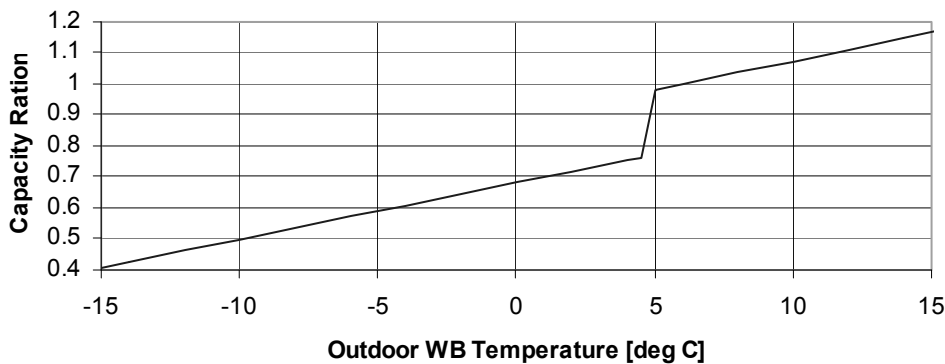

### 5.4 AWAU-YUD036-H13

#### 5.4.1 Cooling Capacity (kW)

Entering Air DB OD Coil(°C)	Data	Entering Air WB/DB ID Coil(°C)				
		15/21	17/24	19/27	21/29	23/32
20	TC	10.00	10.59	11.09	11.58	11.98
	SC	7.13	7.57	8.01	7.77	7.94
	PI	2.53	2.54	2.56	2.57	2.58
25	TC	9.60	10.30	10.89	11.39	11.78
	SC	6.33	6.78	7.17	7.04	7.22
	PI	2.73	2.76	2.78	2.80	2.81
30	TC	9.01	9.70	10.49	10.89	11.29
	SC	6.01	6.49	7.01	6.87	7.15
	PI	2.96	2.99	3.03	3.06	3.07
35	TC	8.32	9.01	9.90	10.40	10.79
	SC	5.66	6.16	6.73	6.65	6.93
	PI	3.20	3.25	3.30	3.33	3.34
40	TC	7.52	8.22	9.11	9.60	10.00
	SC	5.26	5.79	6.37	6.27	6.57
	PI	3.45	3.50	3.56	3.60	3.62
46	TC	6.53	7.23	8.12	8.61	9.01
	SC	4.78	5.30	5.97	5.86	6.13
	PI	3.78	3.84	3.91	3.96	4.00

#### LEGEND

- TC – Total Cooling Capacity, kW
- SC – Sensible Capacity, kW
- PI – Power Input, kW
- WB – Wet Bulb Temp., (°C)
- DB – Dry Bulb Temp., (°C)
- ID – Indoor
- OU – Outdoor

#### 5.4.2 Capacitor Correction Factors

Cooling Capacity Ratio Vs. Outdoor Temperature

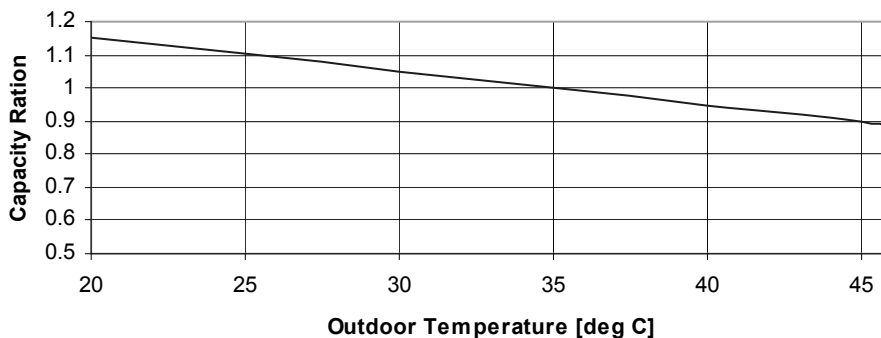

5.4.3 Heating Capacity (kW)

ENTERING WB OD COIL(°C)	ENTERING AIR DB ID COIL(°C)					
	15		20		25	
	TH	PI	TH	PI	TH	PI
-10	5.78	2.44	5.56	2.60	5.34	2.73
-7	6.22	2.50	6.00	2.64	5.78	2.78
-2	6.60	2.53	6.38	2.68	6.16	2.84
2	8.03	2.65	7.70	2.82	7.37	2.99
6	11.33	2.85	11.00	3.05	10.62	3.24
10	12.32	3.01	11.99	3.22	11.66	3.44
15	13.31	3.14	12.98	3.39	12.65	3.60
20	14.03	3.23	13.70	3.51	13.31	3.78

**LEGEND**

- TH – Total Heating Capacity, kW
- PI – Power Input, kW
- WB – Wet Bulb Temp., (°C)
- DB – Dry Bulb Temp., (°C)
- ID – Indoor
- OU – Outdoor

5.4.4 Capacitor Correction Factors

Heating Capacity Ratio Vs. Outdoor Temperature

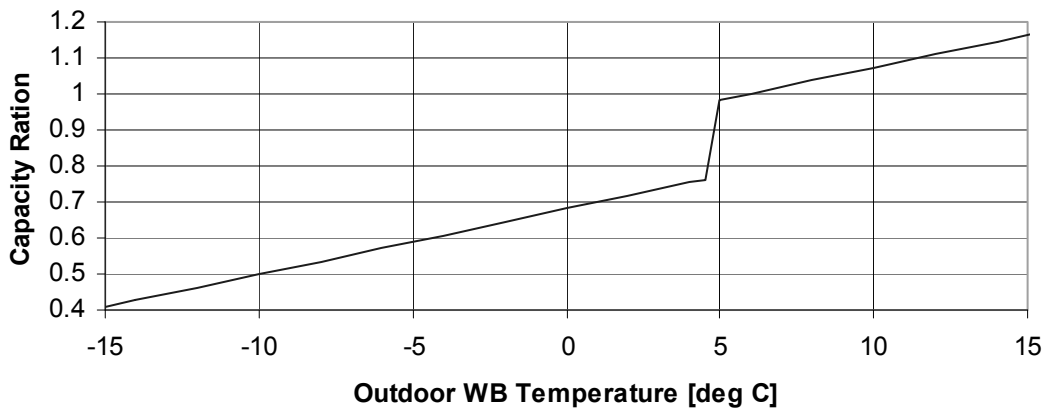

### 5.5 AWAU-YUD042-H13

#### 5.5.1 Cooling Capacity (kW)

Entering Air DB OD Coil(°C)	Data	Entering Air WB/DB ID Coil(°C)				
		15/21	17/24	19/27	21/29	23/32
20	TC	10.91	11.56	12.10	12.64	13.07
	SC	7.78	8.26	8.73	8.48	8.66
	PI	2.64	2.65	2.67	2.68	2.69
25	TC	10.48	11.23	11.88	12.42	12.85
	SC	8.73	9.35	9.89	9.71	9.96
	PI	2.85	2.87	2.90	2.92	2.93
30	TC	9.83	10.58	11.45	11.88	12.31
	SC	8.29	8.96	9.67	9.48	9.87
	PI	3.08	3.12	3.16	3.19	3.20
35	TC	9.07	9.83	10.80	11.34	11.77
	SC	7.81	8.50	9.29	9.18	9.56
	PI	3.33	3.38	3.44	3.47	3.48
40	TC	8.21	8.96	9.94	10.48	10.91
	SC	7.26	7.99	8.78	8.65	9.07
	PI	3.59	3.65	3.71	3.75	3.78
46	TC	7.13	7.88	8.86	9.40	9.83
	SC	6.60	7.31	8.24	8.08	8.46
	PI	3.94	4.00	4.07	4.13	4.17

**LEGEND**

- TC – Total Cooling Capacity, kW
- SC – Sensible Capacity, kW
- PI – Power Input, kW
- WB – Wet Bulb Temp., (°C)
- DB – Dry Bulb Temp., (°C)
- ID – Indoor
- OU – Outdoor

#### 5.5.2 Capacity Correction Factors

Cooling Capacity Ratio Vs. Outdoor Temperature

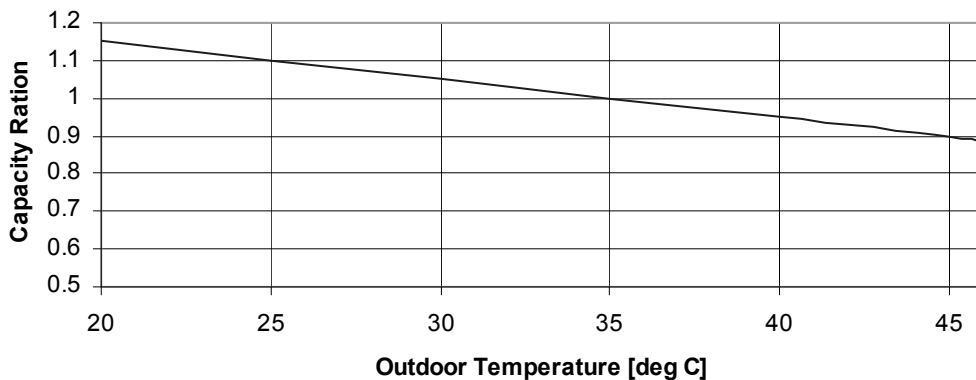

5.5.3 Heating Capacity (kW)

	ENTERING AIR DB ID COIL(°c)					
	15		20		25	
ENTERING WB OD COIL(°C)	TH	PI	TH	PI	TH	PI
-10	6.20	2.76	5.96	2.94	5.72	3.09
-7	6.67	2.83	6.43	2.98	6.20	3.15
-2	7.08	2.86	6.84	3.04	6.61	3.21
2	8.61	3.00	8.26	3.19	7.91	3.38
6	12.15	3.23	11.80	3.45	11.39	3.66
10	13.22	3.41	12.86	3.64	12.51	3.89
15	14.28	3.55	13.92	3.83	13.57	4.07
20	15.05	3.66	14.69	3.97	14.28	4.28

**LEGEND**

- TH – Total Heating Capacity, kW
- PI – Power Input, kW
- WB – Wet Bulb Temp., (°C)
- DB – Dry Bulb Temp., (°C)
- ID – Indoor
- OU – Outdoor

5.5.4 Capacity Correction Factors

Heating Capacity Ratio Vs. Outdoor Temperature

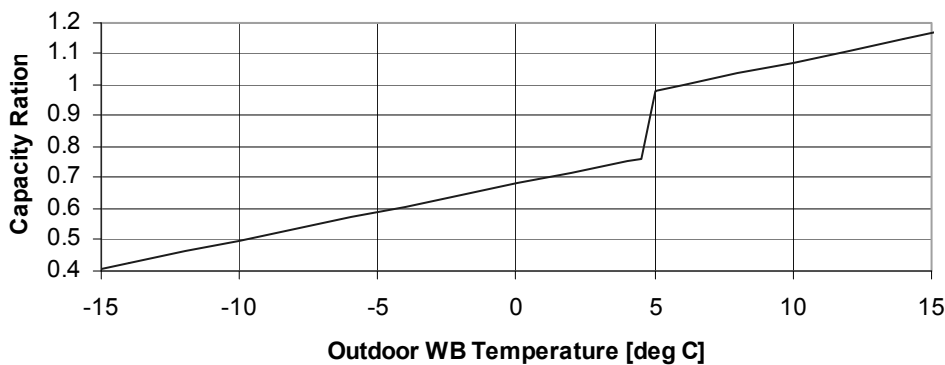

## 5.6 AWAU-YUD048-H13

### 5.6.1 Cooling Capacity (kW)

Entering Air DB OD Coil(°C)	Data	Entering Air WB/DB ID Coil(°C)				
		15/21	17/24	19/27	21/29	23/32
20	TC	14.14	14.98	15.68	16.38	16.94
	SC	10.08	10.71	11.32	10.99	11.23
	PI	3.35	3.37	3.39	3.41	3.42
25	TC	13.58	14.56	15.40	16.10	16.66
	SC	8.95	9.58	10.14	9.95	10.21
	PI	3.62	3.65	3.68	3.71	3.72
30	TC	12.74	13.72	14.84	15.40	15.96
	SC	8.50	9.18	9.92	9.72	10.11
	PI	3.92	3.96	4.02	4.05	4.06
35	TC	11.76	12.74	14.00	14.70	15.26
	SC	8.01	8.71	9.52	9.41	9.79
	PI	4.23	4.30	4.37	4.40	4.42
40	TC	10.64	11.62	12.88	13.58	14.14
	SC	7.44	8.19	9.00	8.86	9.29
	PI	4.56	4.63	4.72	4.76	4.80
46	TC	9.24	10.22	11.48	12.18	12.74
	SC	6.76	7.50	8.44	8.28	8.67
	PI	5.00	5.09	5.17	5.24	5.30

#### LEGEND

- TC – Total Cooling Capacity, kW
- SC – Sensible Capacity, kW
- PI – Power Input, kW
- WB – Wet Bulb Temp., (°C)
- DB – Dry Bulb Temp., (°C)
- ID – Indoor
- OU – Outdoor

### 5.6.2 Capacity Correction Factors

Cooling Capacity Ratio Vs. Outdoor Temperature

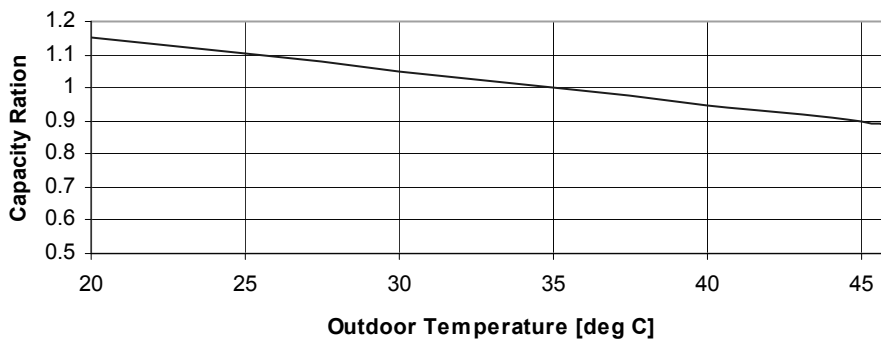

5.6.3 Heating Capacity (kW)

ENTERING WB OD COIL(°C)	ENTERING AIR DB ID COIL(°c)					
	15		20		25	
	TH	PI	TH	PI	TH	PI
-10	8.66	3.66	8.33	3.90	8.00	4.10
-7	9.32	3.76	8.99	3.96	8.66	4.18
-2	9.90	3.80	9.57	4.03	9.24	4.26
2	12.05	3.98	11.55	4.24	11.06	4.49
6	17.00	4.28	16.50	4.58	15.92	4.86
10	18.48	4.52	17.99	4.83	17.49	5.17
15	19.97	4.72	19.47	5.08	18.98	5.40
20	21.04	4.85	20.54	5.27	19.97	5.68

**LEGEND**

- TH – Total Heating Capacity, kW
- PI – Power Input, kW
- WB – Wet Bulb Temp., (°C)
- DB – Dry Bulb Temp., (°C)
- ID – Indoor
- OU – Outdoor

5.6.4 Capacity Correction Factors

Heating Capacity Ratio Vs. Outdoor Temperature

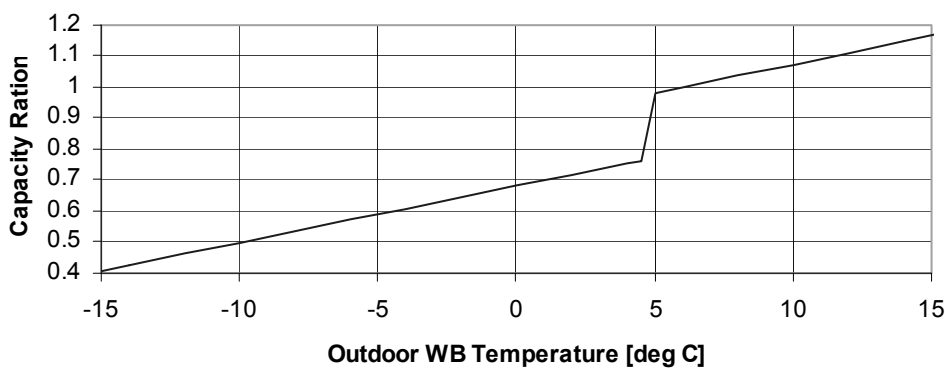



### 5.7 AWAU-YUD060-H13

#### 5.7.1 Cooling Capacity (kW)

Entering Air DB OD Coil(°C)	Data	Entering Air WB/DB ID Coil(°C)				
		15/21	17/24	19/27	21/29	23/32
20	TC	17.17	18.19	19.04	19.89	20.57
	SC	12.24	13.01	13.75	13.35	13.64
	PI	4.07	4.09	4.11	4.13	4.14
25	TC	16.49	17.68	18.70	19.55	20.23
	SC	10.87	11.64	12.31	12.09	12.40
	PI	4.39	4.43	4.47	4.50	4.51
30	TC	15.47	16.66	18.02	18.70	19.38
	SC	10.32	11.15	12.04	11.80	12.28
	PI	4.75	4.81	4.87	4.91	4.92
35	TC	14.28	15.47	17.00	17.85	18.53
	SC	9.72	10.58	11.56	11.42	11.89
	PI	5.14	5.22	5.30	5.34	5.36
40	TC	12.92	14.11	15.64	16.49	17.17
	SC	9.03	9.94	10.93	10.76	11.29
	PI	5.53	5.62	5.72	5.78	5.82
46	TC	11.22	12.41	13.94	14.79	15.47
	SC	8.21	9.10	10.25	10.06	10.53
	PI	6.07	6.17	6.28	6.36	6.42

**LEGEND**

- TC – Total Cooling Capacity, kW
- SC – Sensible Capacity, kW
- PI – Power Input, kW
- WB – Wet Bulb Temp., (°C)
- DB – Dry Bulb Temp., (°C)
- ID – Indoor
- OU – Outdoor

#### 5.7.2 Capacity Correction Factors

Cooling Capacity Ratio Vs. Outdoor Temperature

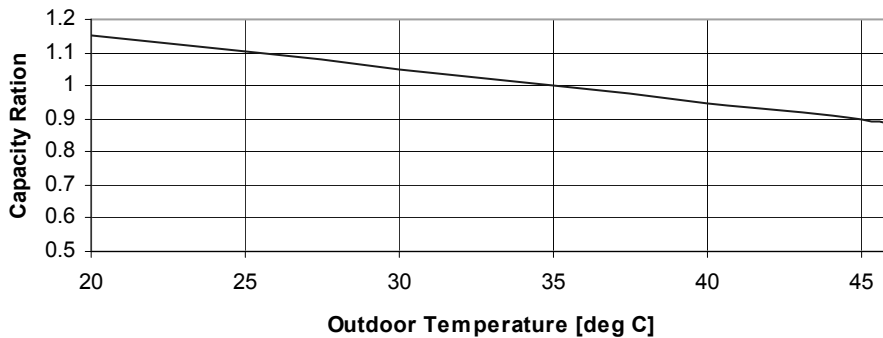

5.7.3 Heating Capacity (kW)

	ENTERING AIR DB ID COIL(°c)					
	15		20		25	
ENTERING WB OD COIL(°C)	TH	PI	TH	PI	TH	PI
-10	9.45	4.00	9.09	4.26	8.73	4.48
-7	10.17	4.10	9.81	4.33	9.45	4.56
-2	10.80	4.15	10.44	4.40	10.08	4.65
2	13.14	4.35	12.60	4.63	12.06	4.90
6	18.54	4.68	18.00	5.00	17.37	5.31
10	20.16	4.94	19.62	5.28	19.08	5.64
15	21.78	5.15	21.24	5.55	20.70	5.90
20	22.95	5.30	22.41	5.75	21.78	6.20

**LEGEND**

- TH – Total Heating Capacity, kW
- PI – Power Input, kW
- WB – Wet Bulb Temp., (°C)
- DB – Dry Bulb Temp., (°C)
- ID – Indoor
- OU – Outdoor

5.7.4 Capacity Correction Factors

Heating Capacity Ratio Vs. Outdoor Temperature

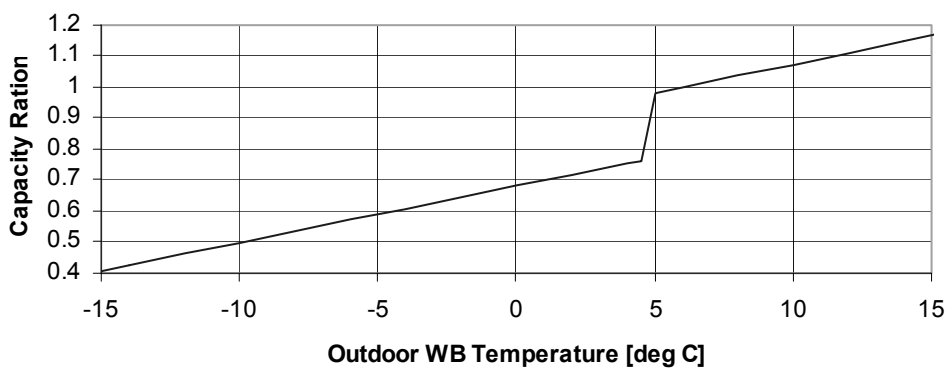

## 5.8 Capacity Correction Factor Due to Tubing Length

### 5.8.1 Cooling

Model	TOTAL TUBING LENGTH								
	3m	7.5m	10m	15m	20m	25m	30m	40m	50m
	1.02	1	0.98	0.96	0.95	0.95	0.93	0.91	0.89

\* Minimum recommended tubing length between indoor and outdoor units is 3m.

### 5.8.2 Heating

Model	TOTAL TUBING LENGTH								
	3m	7.5m	10m	15m	20m	25m	30m	40m	50m
	1.02	1	0.98	0.96	0.95	0.95	0.93	0.91	0.89

\* Minimum recommended tubing length between indoor and outdoor units is 3m.

## 6. AIRFLOW CURVES

### 6.1 Model: AWSI-DBD024-N11

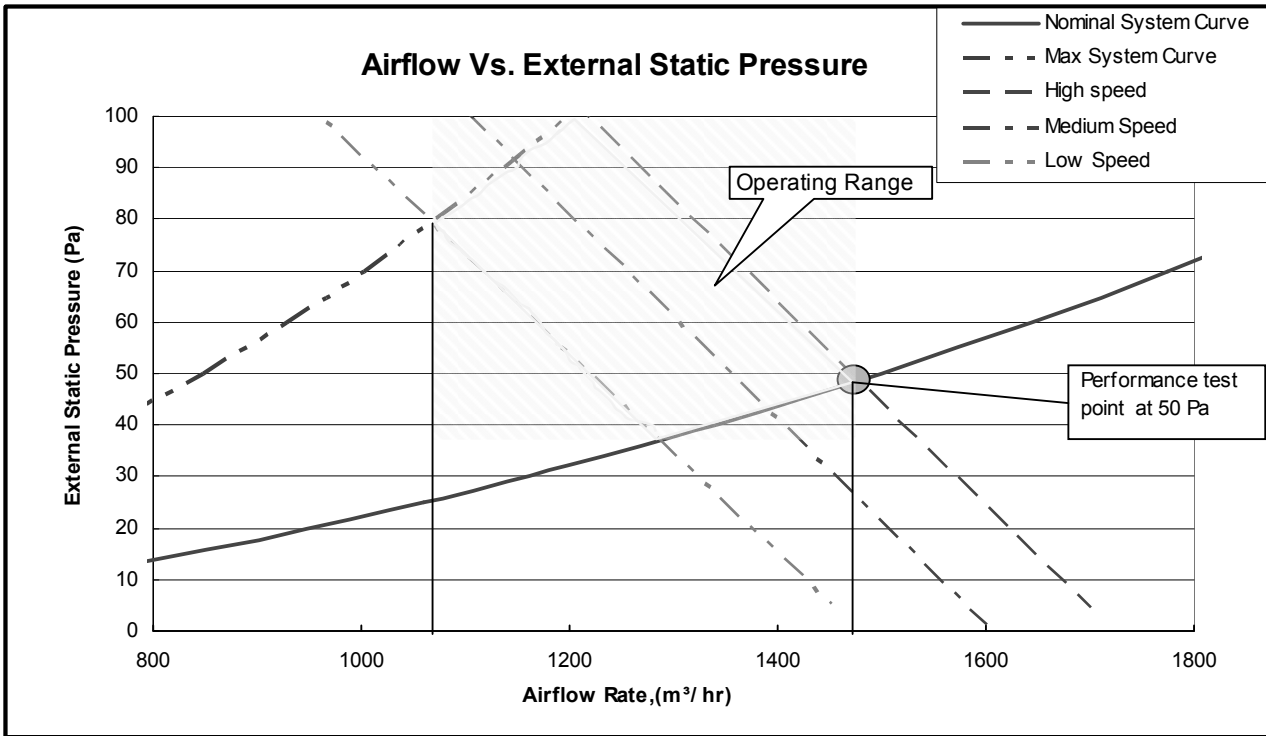

### 6.2 Model: AWSI-DBD030-N11

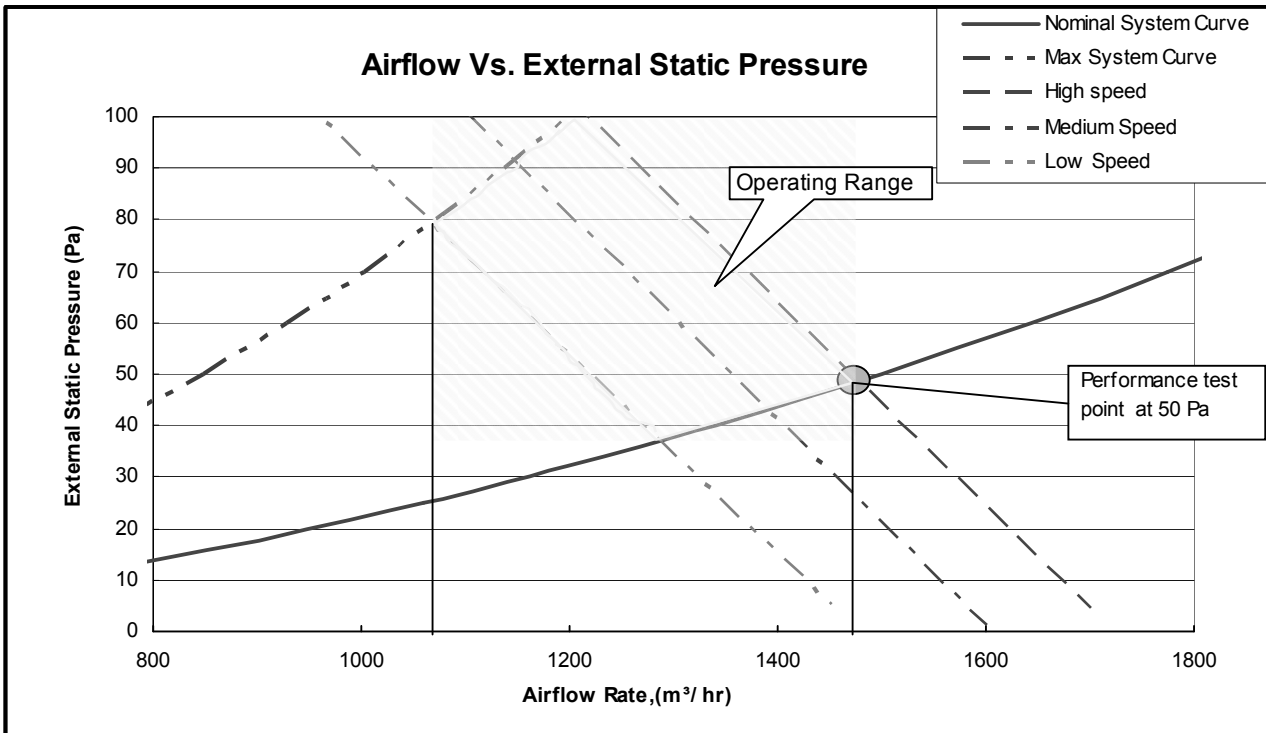

6.3 Model: AWSI-DBD036-N11

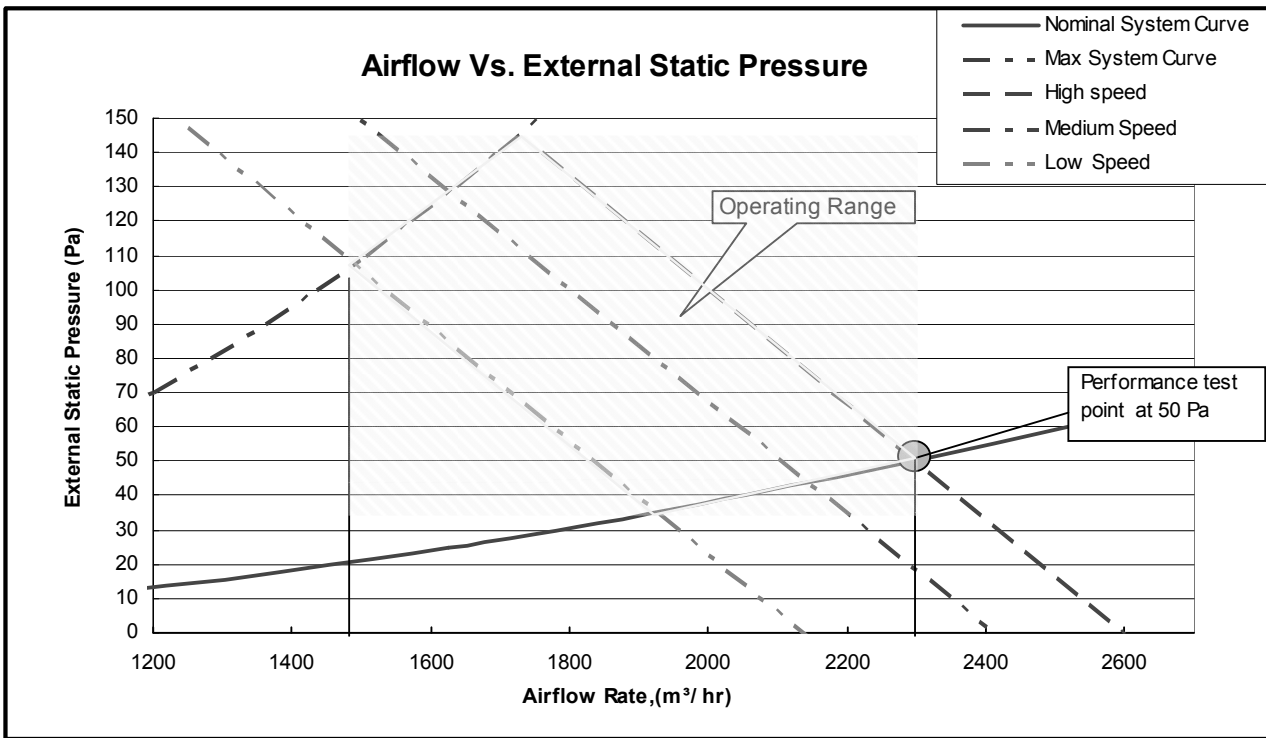

6.4 Model: AWSI-DBD048-N11

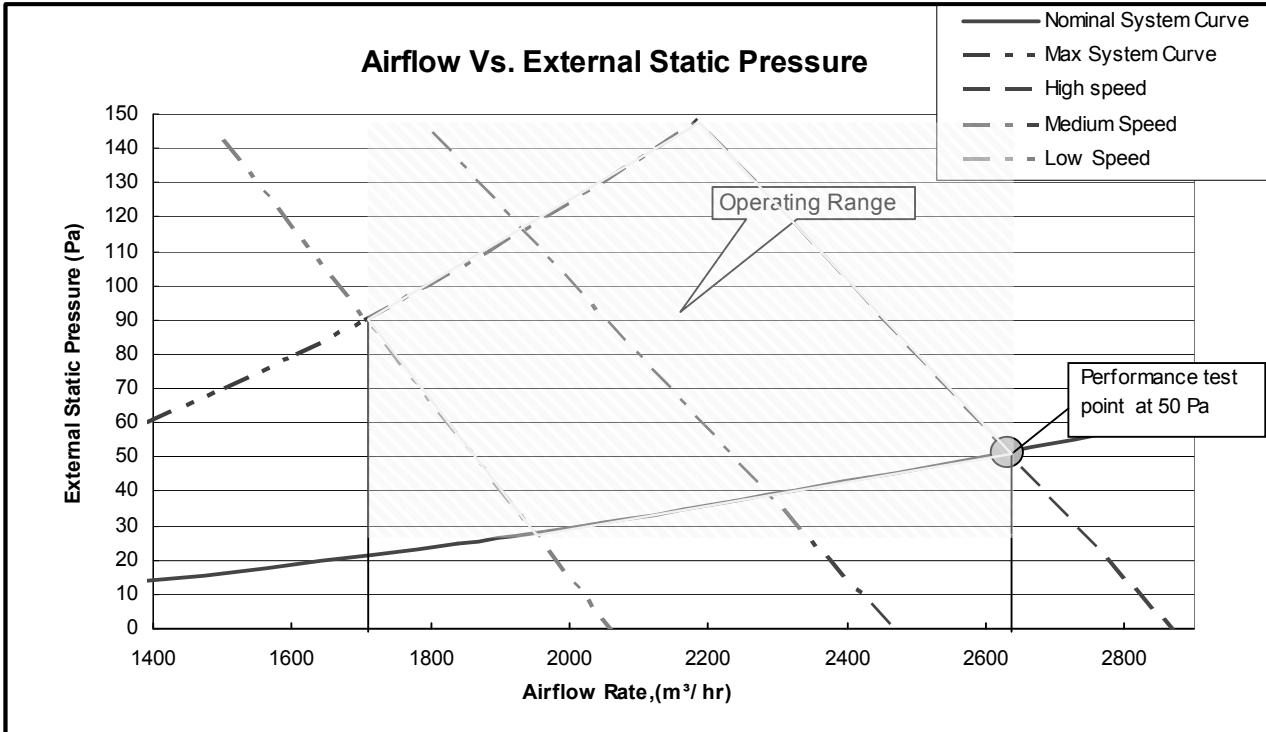

6.5 Model: AWSI-DBD060-N11

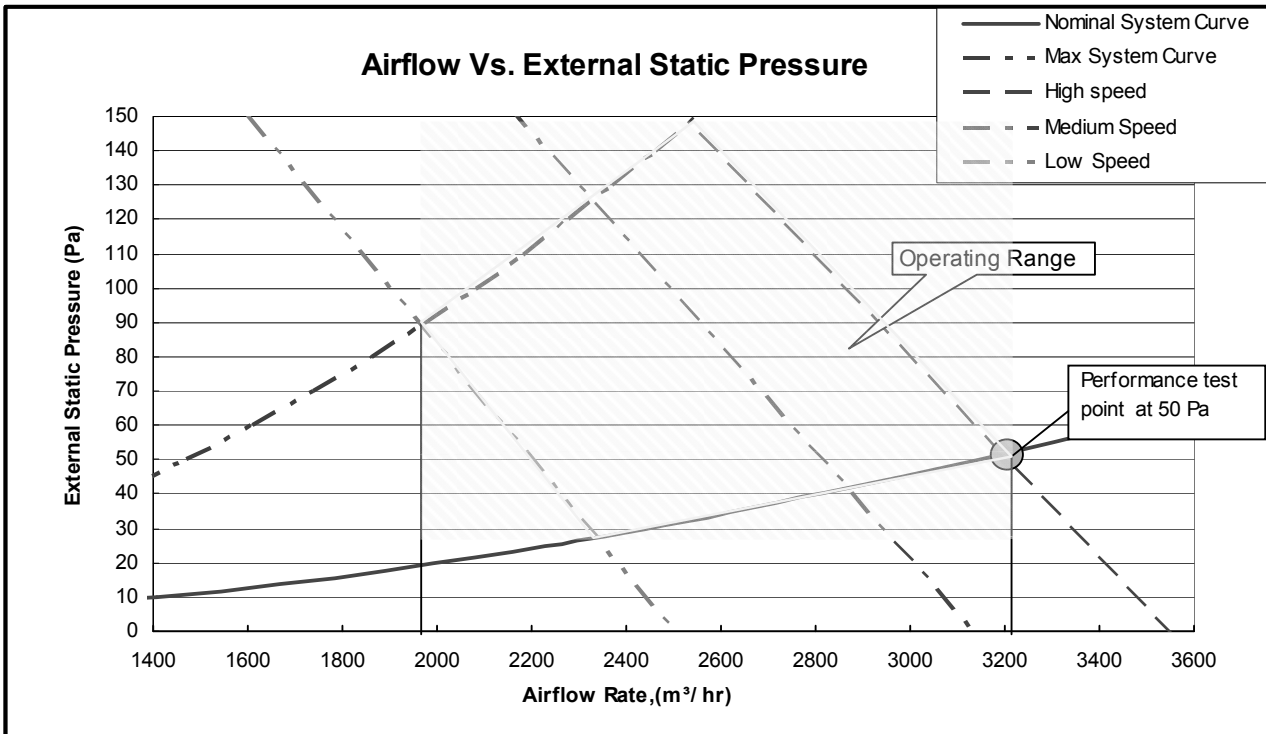

## 7. ELECTRICAL DATA

MODEL	YUD024	YUD030	YUD036	YUD036	YUD042	YUD048	YUD060
Power Supply	Separately						
	1PH-220-240V-50Hz			3PH-380-415V-50Hz			
Capability of Air Switch(A) (Indoor)	10A						
Capability of Air Switch(A) (Outdoor)	20A	25A	32A	16A	20A	25A	
Power Supply Wiring No. X Cross Section mm <sup>2</sup> (ODU)	3x4.0mm <sup>2</sup>			5x2.5mm <sup>2</sup>		5 x4.0mm <sup>2</sup>	
Power Supply Wiring No. X Cross Section mm <sup>2</sup> (IDU)	3 x1.5mm <sup>2</sup>						
Interconnecting Cable Model No. X Cross Section mm <sup>2</sup>	2x0.75mm <sup>2</sup>						

### NOTE

Power wiring cord should comply with local laws and electrical regulations requirements.

8. WIRING DIAGRAMS

8.1 AWAU-YUD024-H11, AWAU-YUD030-H11

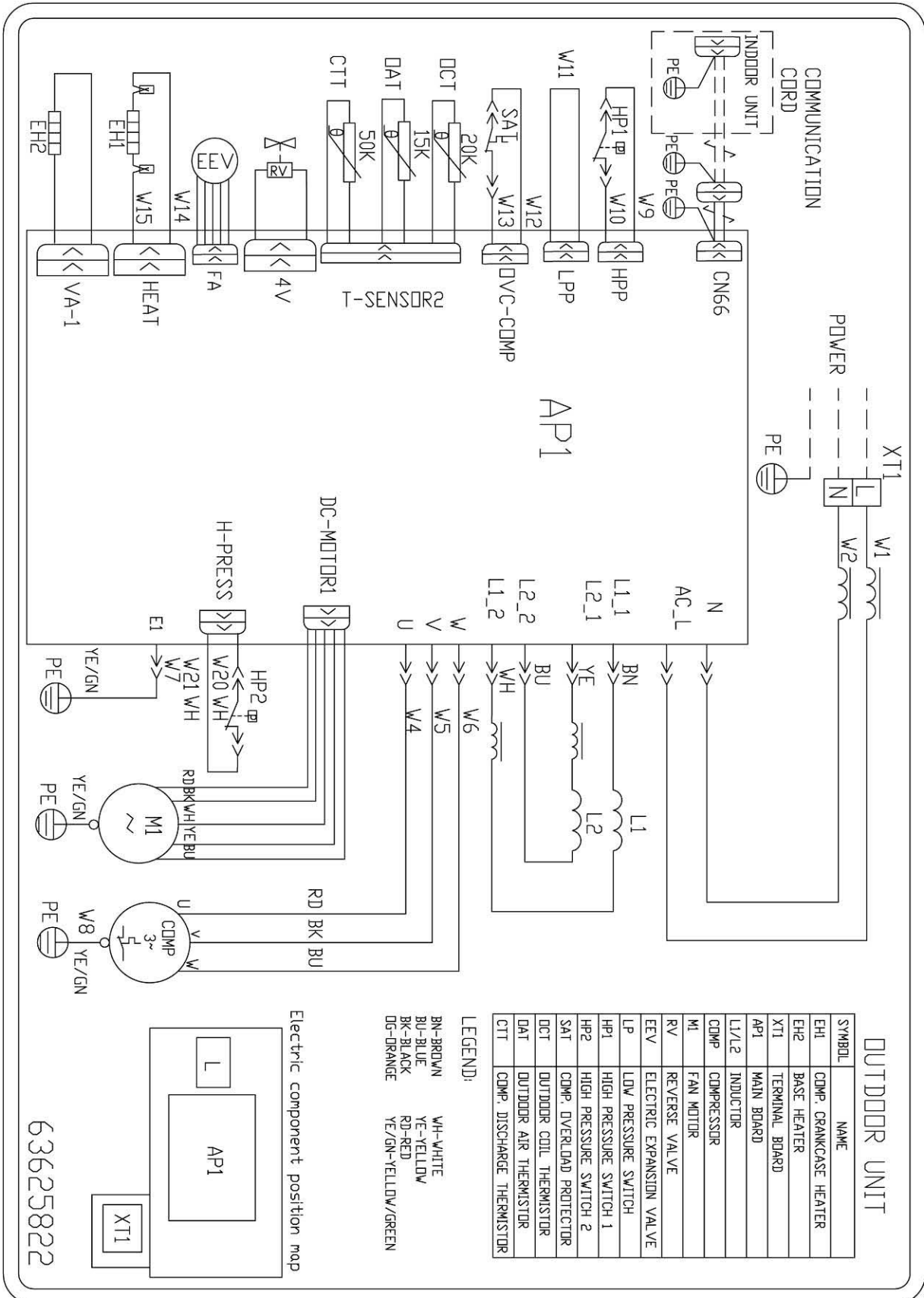



8.2 AWAU-YUD036-H11

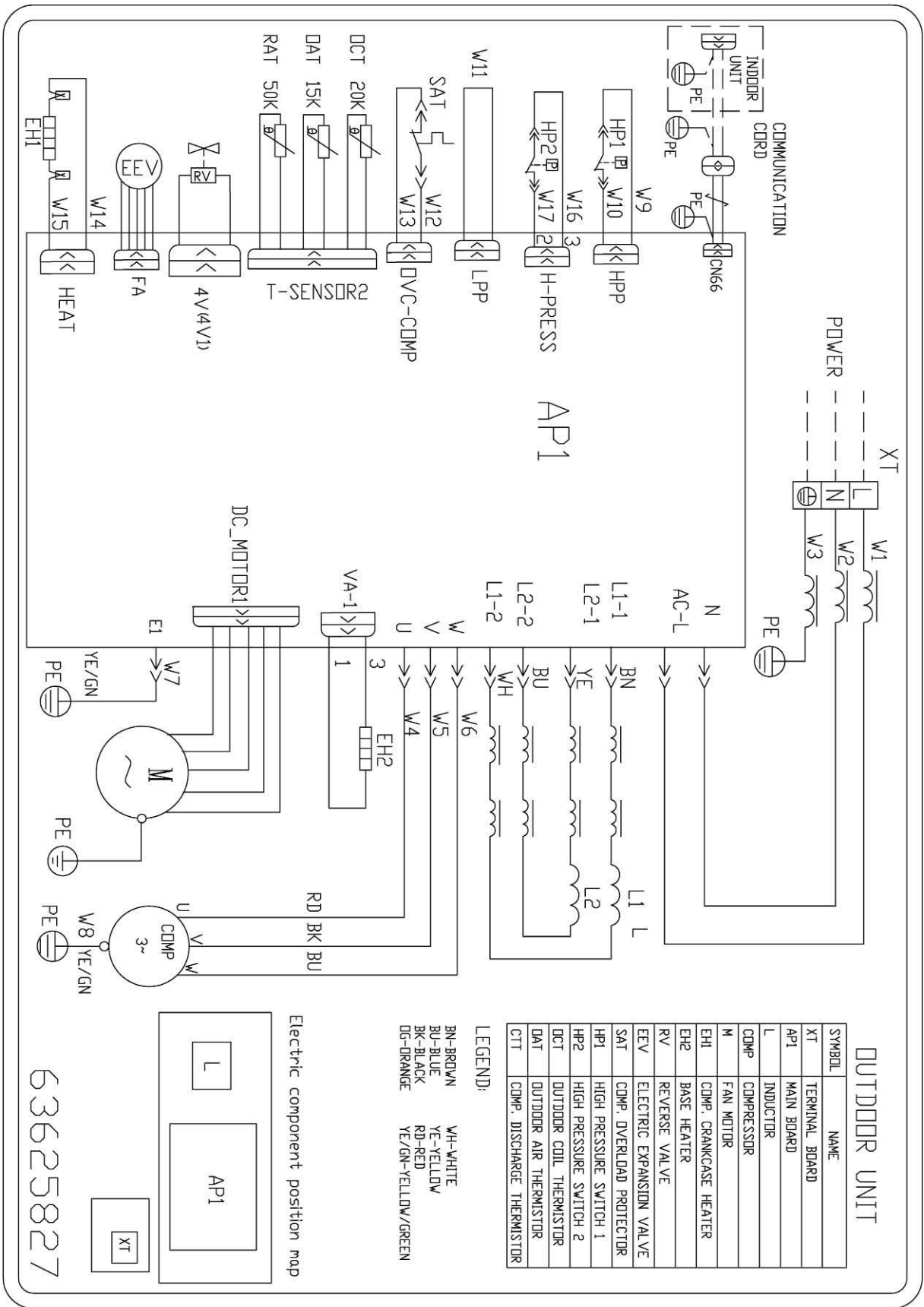

8.3 AWAU-YUD036-H13 , AWAU-YUD042-H13

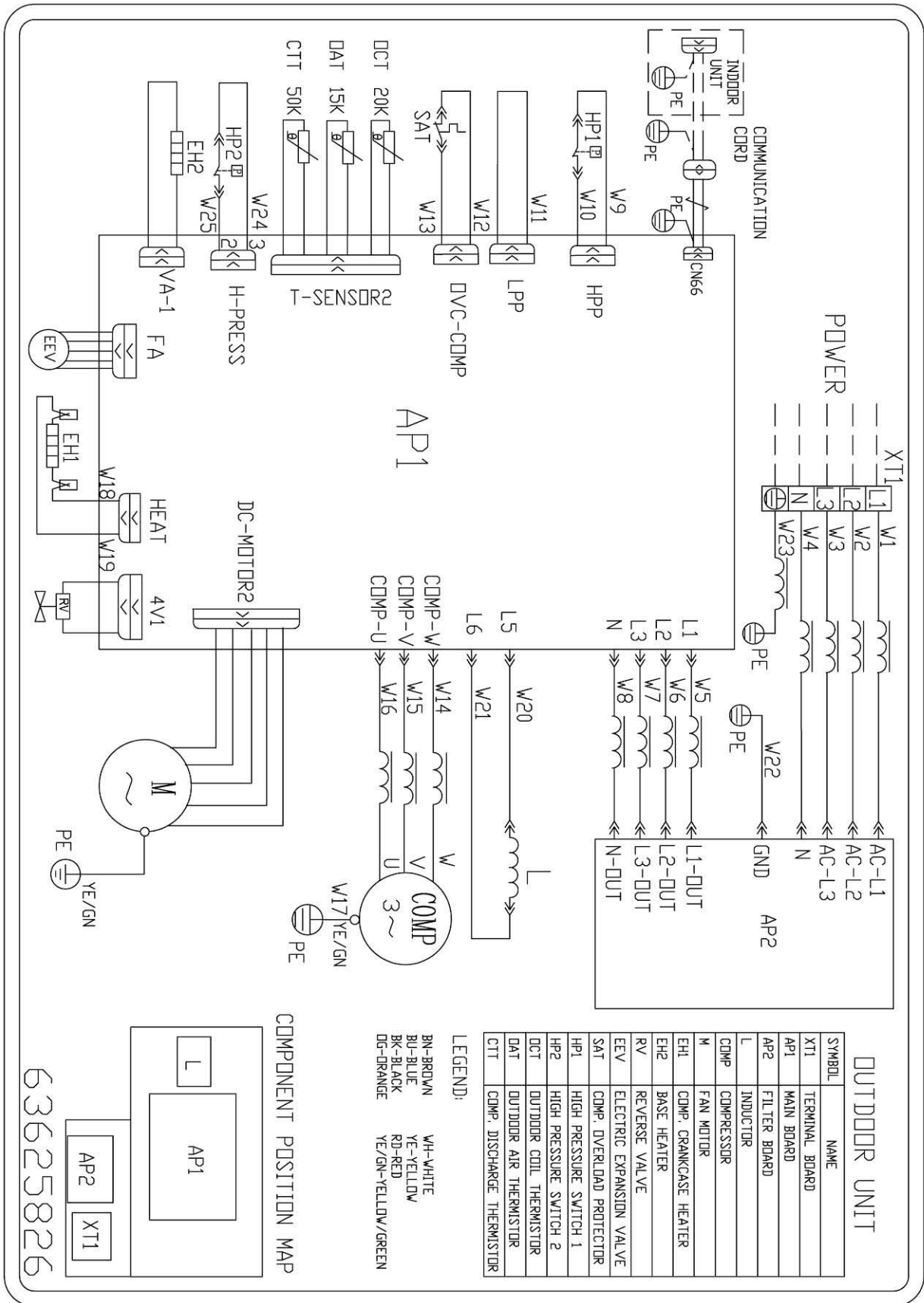

### 8.4 AWAU-YUD048-H13, AWAU-YUD060-H13

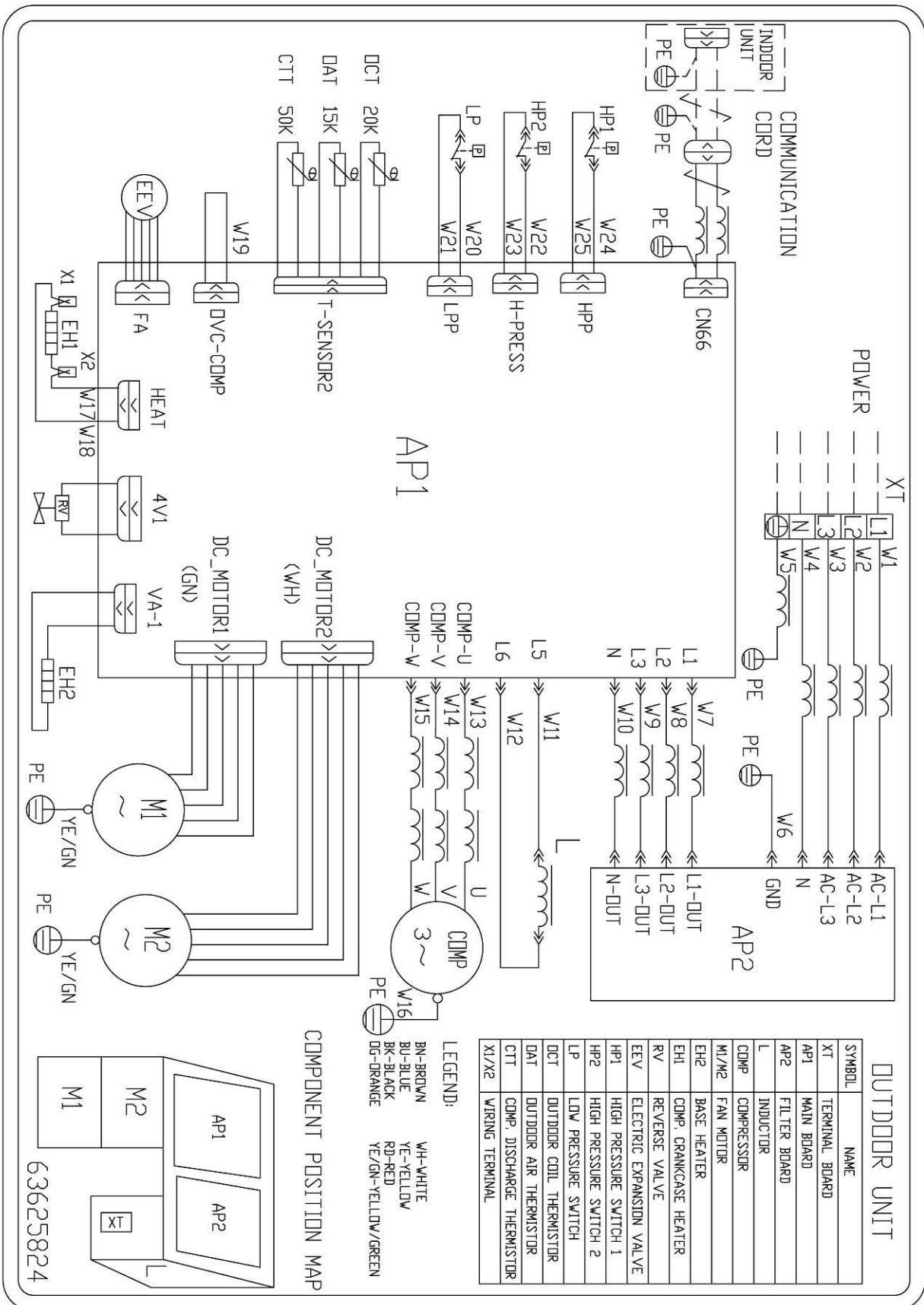

8.5 AWSI-CAD024-N11

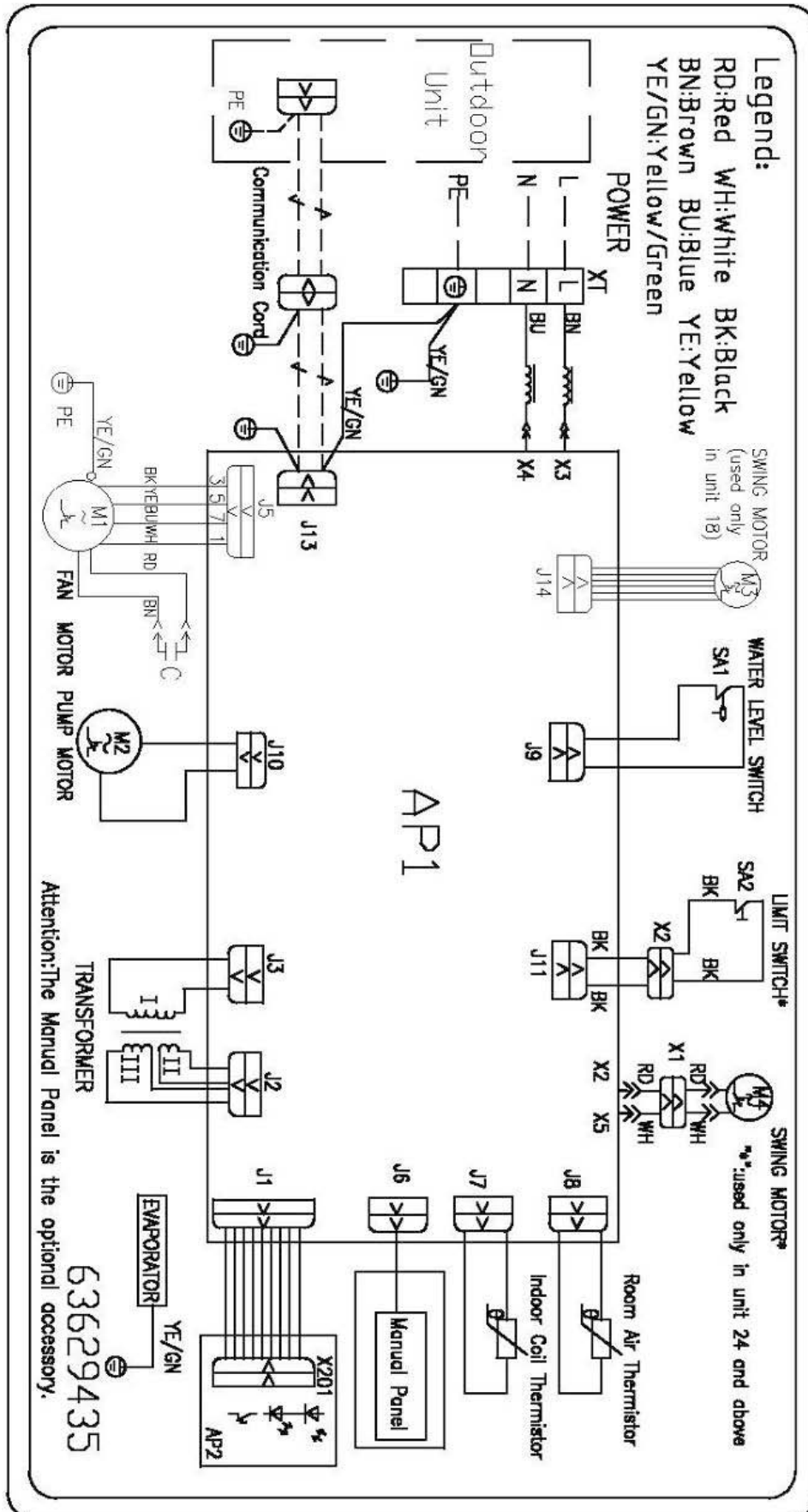

8.6 AWSI-CAD030/036/042-N11

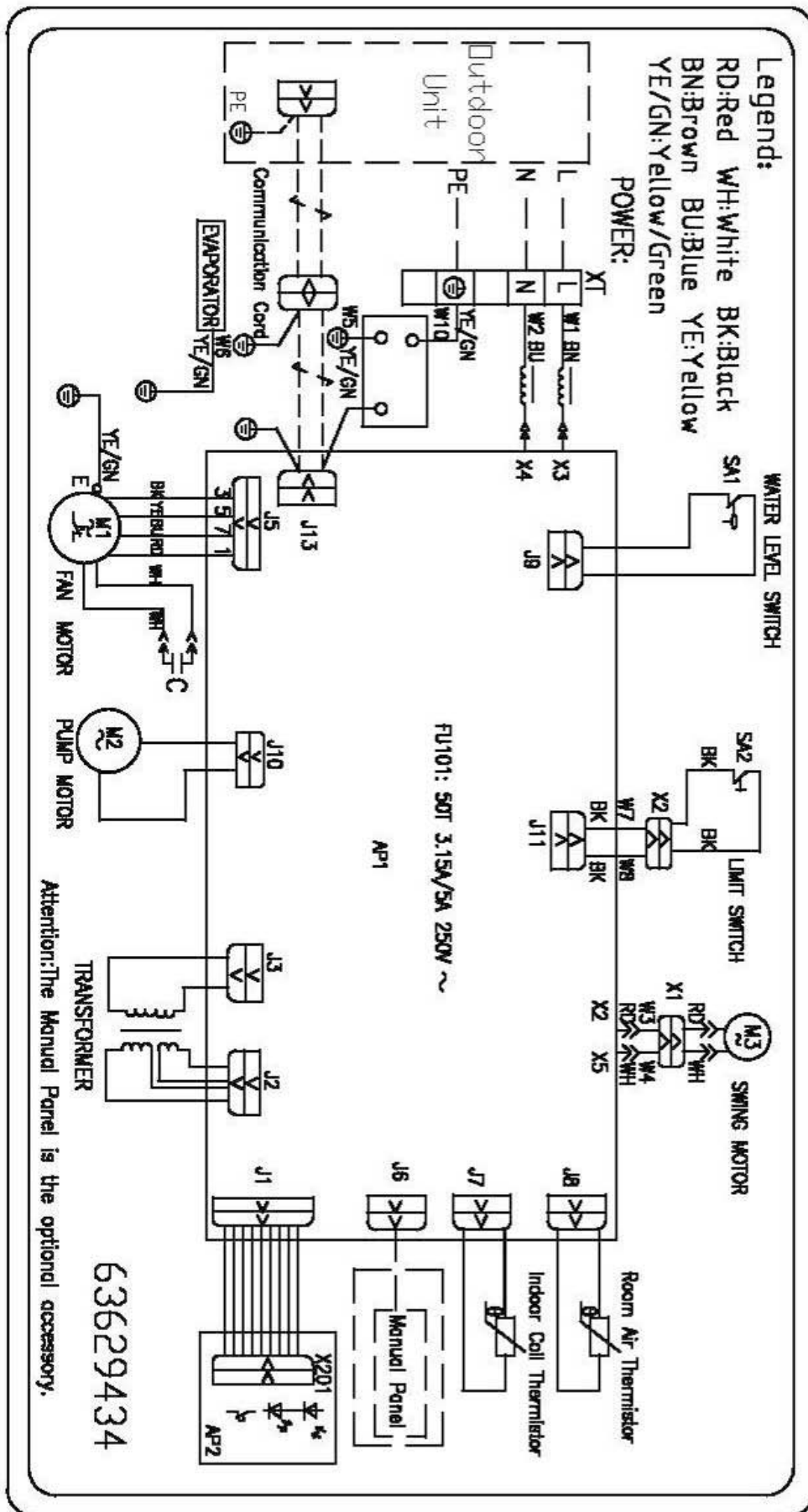

8.7 AWSI-FAD024-N11

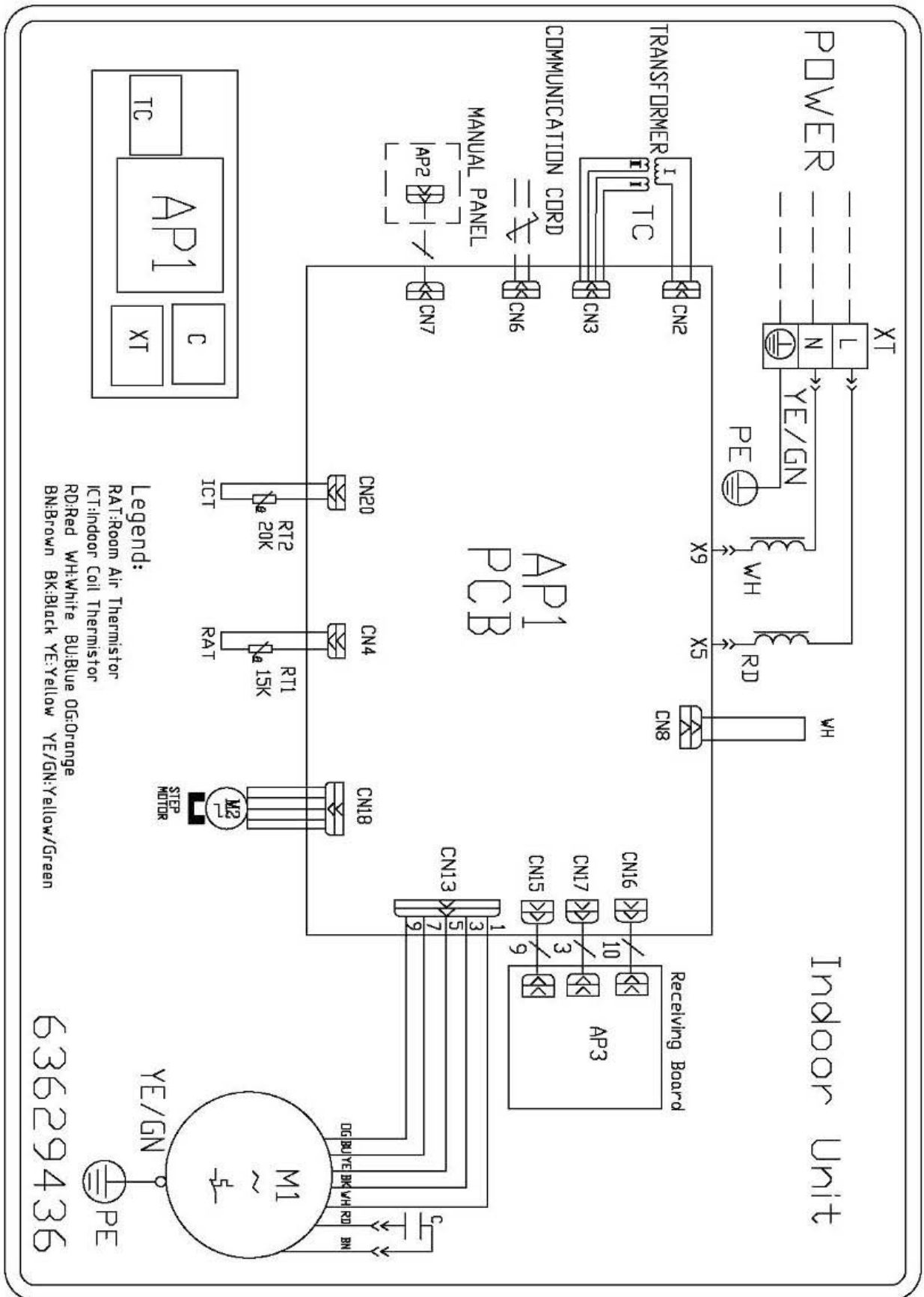

8.8 AWSI-FAD030/036/048-N11

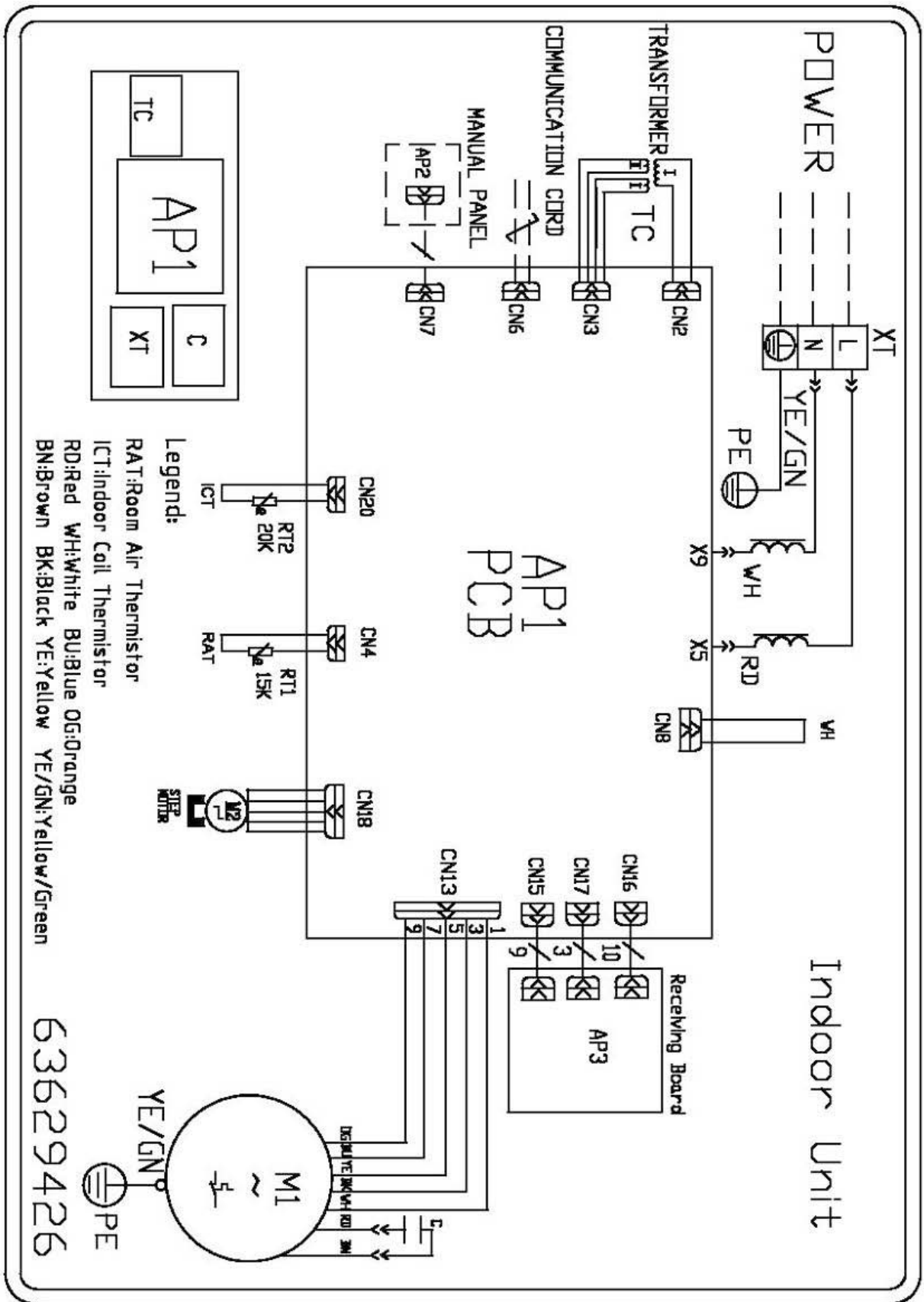

8.9 AWSI-DBD024/030/036/048/060-N11

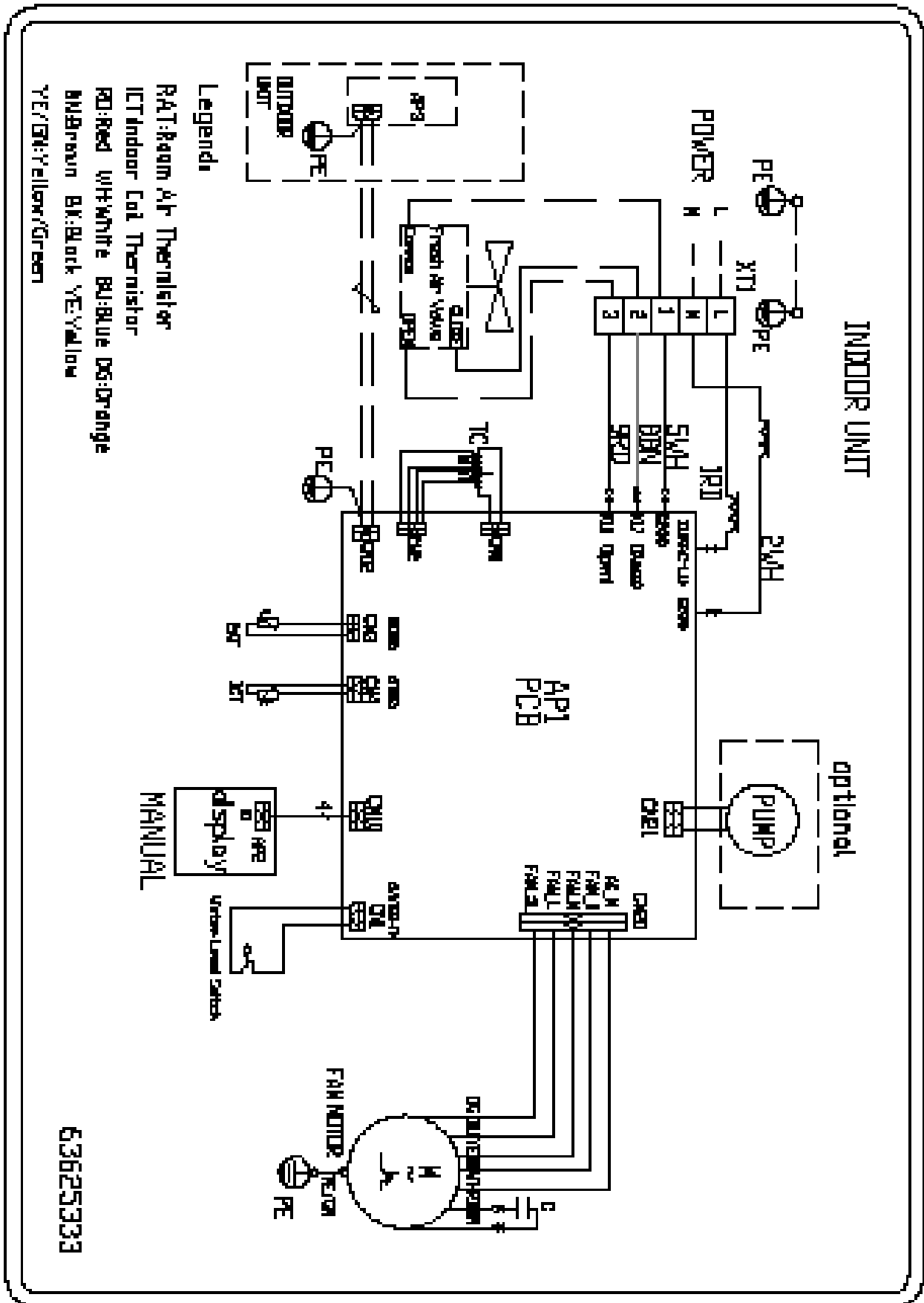



## 9. REFRIGERATION DIAGRAMS

### 9.1 Cooling Mode

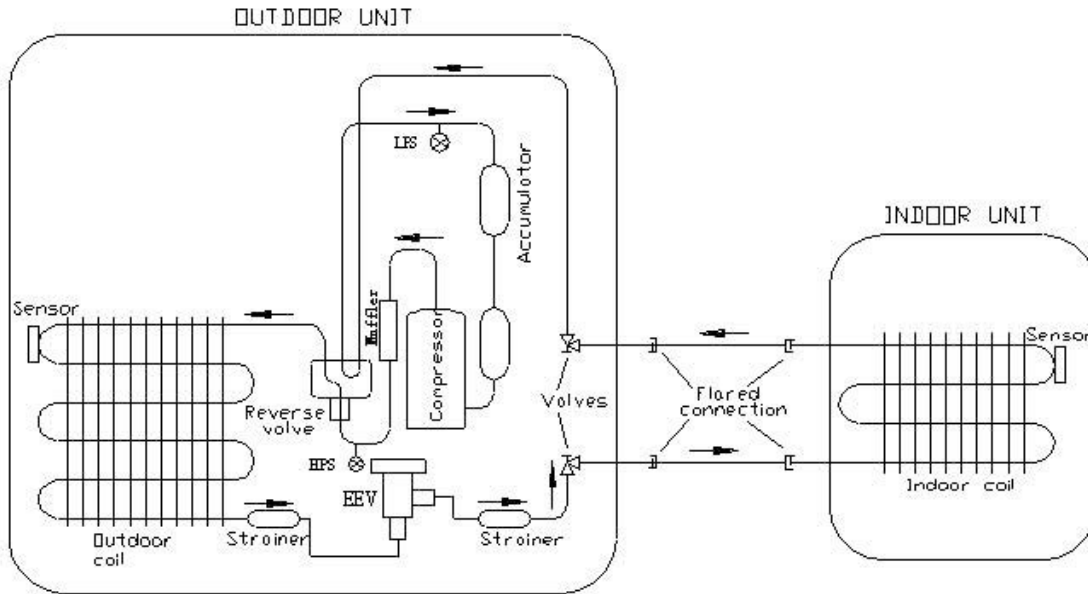

COOLING & DRY MODE

### 9.2 Heating Mode

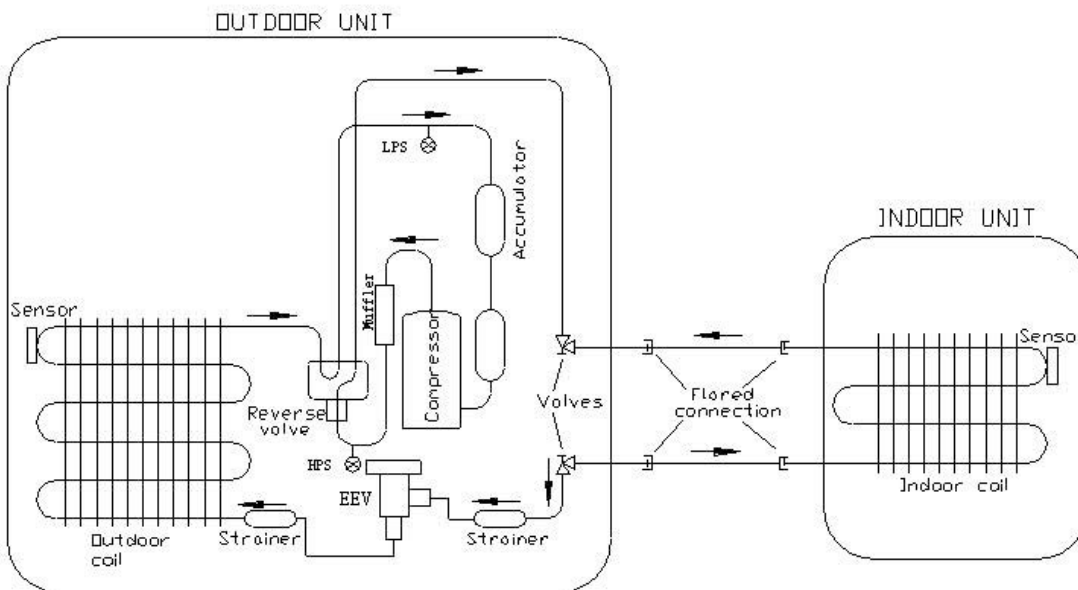

HEATING MODE

10. TUBING CONNECTIONS

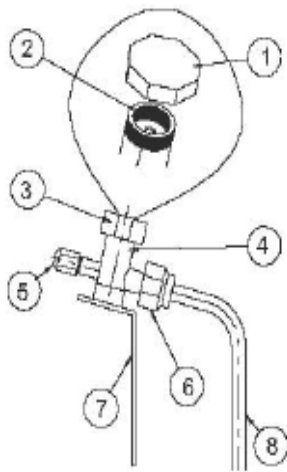
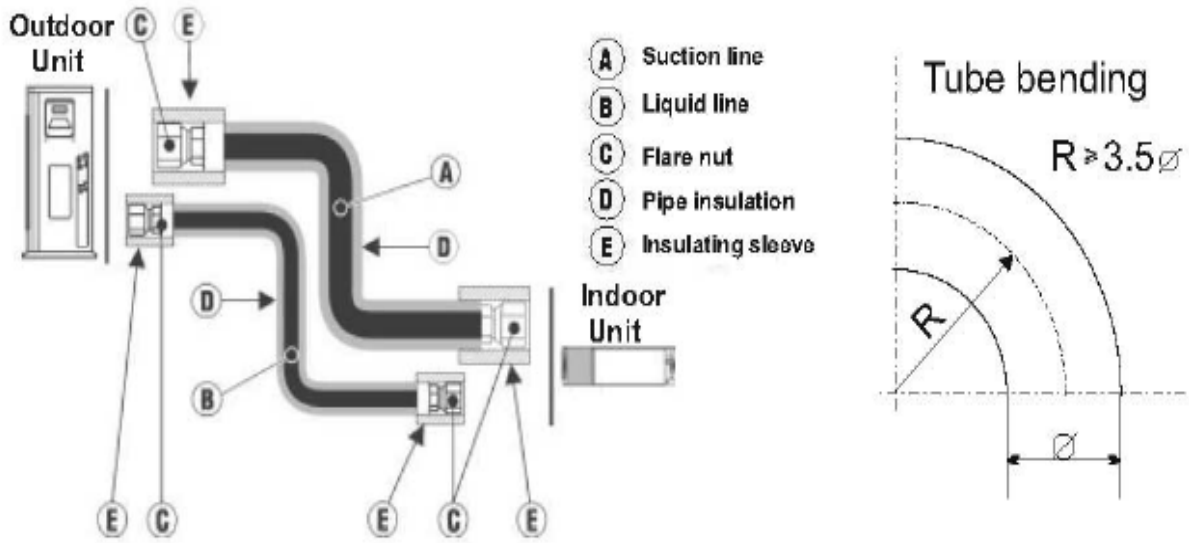

TUBE (Inch)	1/4"	3/8"	1/2"	5/8"	3/4"
<b>TORQUE (Nm)</b>					
<b>Flare Nuts</b>	15-18	40-45	60-65	70-75	80-85
<b>Valve Cap</b>	13-20	13-20	18-25	18-25	40-50
<b>Service Port Cap</b>	11-13	11-13	11-13	11-13	11-13

1. Valve Protection Cap-end
2. Refrigerant Valve Port (use Allen wrench to open/close)
3. Valve Protection Cap
4. Refrigerant Valve
5. Service Port Cap
6. Flare Nut
7. Unit Back Side
8. Copper Tube

When the outdoor unit is installed above the indoor unit an oil trap is required every 5m along the suction line at the lowest point of the riser. In case the indoor unit is installed above the outdoor, no trap is required.

## 11. CONTROL SYSTEM

### 11.1 Electronic Control

#### 11.1.1 Abbreviations

Abbreviation	Definition
A/C	Air Condition
BMS	Building Management System
PWR	System Power
CTT	Compressor Top Temperature sensor
DCI	DC Inverter
EEV	Electronic Expansion Valve
HE	Heating Element
HMI	Human Machine Interface
HST	Heat Sink Temperature sensor
Hz	Hertz (1/sec) – electrical frequency
ICT	Indoor Coil Temperature (RT2) sensor
IDU	Indoor Unit
MCU	Micro Controller Unit
OAT	Outdoor Air Temperature sensor
OCT	ODU Coil Temperature sensor
ODU	Outdoor Unit
OFAN	Outdoor Fan
PFC	Power Factor Corrector
RAC	Residential A/C
RC	Reverse Cycle (Heat Pump)
RGT	Return Gas Temperature sensor
RPS	Rounds per second (mechanical speed)
RV	Reverse Valve
SB,STBY	Stand By
SUCT	Compressor Suction Temperature sensor
S/W	Software
TBD	To Be Defined
TMR	Timer

#### 11.1.2 System Operation Concept

The control function is divided between indoor and outdoor unit controllers. Indoor unit is the system 'Master', requesting the outdoor unit for cooling/heating capacity supply. The outdoor unit is the system 'Slave' and it must supply the required capacity unless it enters into a protection mode avoiding it from supplying the requested capacity.

Target frequency is transferred via indoor to outdoor communication, and the calculation is based on room temperature and set point temperature.

#### 11.1.3 Compressor Frequency Control

The Compressor Frequency Control is based on the PI scheme.

When starting the compressor, or when conditions are varied due to the change of the room condition, the frequency must be initialized according to the  $\Delta D$  value of the indoor unit and the  $Q$  value of the indoor unit.

**Q value:** Indoor unit output determined from indoor unit capacity, air flow rate and other factors.

##### 1. P control

Calculate  $\Delta D$  value in each sampling time (20 seconds), and adjust the frequency according to its difference from the frequency previously calculated.

**2. I control**

If the operating frequency is not change more than a certain fixed time, adjust the frequency up and down according to the  $\Delta D$  value.

Obtaining the fixed  $\Delta D$  value

When the  $\Delta D$  value is small- decrease the frequency

When the  $\Delta D$  value is large- increase the frequency

**3. Frequency management when other controls are functioning**

When frequency is drooping;

Frequency management is carried out only when the frequency droops.

For limiting lower limit

Frequency management is carried out only when the frequency rises.

**4. Maximum and minimum limits of frequency by PI control**

The frequency upper and lower limits are set depending on indoor unit.

When low noise commands come from the indoor unit or when outdoor unit low noise or quiet commands come from indoor unit, the upper limit frequency must be lowered than the usual setting.

**11.1.3.1 Frequency range**

The compressor frequency limitation is set by the following table

Mode	Minimum Frequency(MinFreq)						
	24	30	36	36	42	48	60
Cooling	20	20	20	20	20	20	20
Heating	20	20	20	20	20	20	20

The maximum allowed frequency is extracted from the following:

Mode	ODU IDU	Maximum Frequency(MaxFreq)						
		YUD 024	YUD 030	YUD 036	YUD 036T	YUD042	YUD 048	YUD 060
Cooling	DBD	65	72	66	66	-	70	70
	CAD	68	70	70	70	77	-	-
	FAD	70	70	70	70	-	70	-
Heating	DBD	65	68	65	65	-	75	74
	CAD	65	70	68	72	75	-	-
	FAD	65	70	70	70	-	75	-

**11.1.4.1 Frequency Changes Control**

Frequency change rate is 1 Hz/sec.

**11.1.4.2 Minimum On and Off Time**

Prohibit turning ON the compressor for 3 minutes after turning it off.(except during deicing protection)

### 11.1.5 Indoor Fan Control

3 Indoor fan speeds are determined for each model.

The cassette unit indoor fan speed table

Unit Model	High	Medium	Low
24	670	620	570
30	710	660	610
36	710	660	610
42	710	660	610

The floor/ceiling cassette unit indoor fan speed table

Unit Model	High	Medium	Low
24	1200	1000	880
30	1000	920	820
36	1280	1140	980
48	1500	1350	1190

The duct unit indoor fan speed table

Unit Model	High	Medium	Low
24	1250	1220	1060
30	1250	1220	1060
36	1320	1090	910
48	1320	1090	910
60	930	830	650

In high/ medium/ low indoor fan user setting, unit will operate fan in selected speed.

In Auto Fan user setting, fan speed will be adjusted automatically according to the difference between actual room temperature(RAT) and user set point temperature(SPT).

Indoor Fan speed		High	Medium	Low
RAT-SPT	Cooling	$\geq 2$	(0,2)	$\leq 0$
	Heating	$\leq 1$	(1,3)	$\geq 3$

In DRY mode, the automatic fan speed is forced to be low.

#### 11.1.5.1 Turbo Speed

In COOL and HEAT mode (not available in AUTO, DRY, FAN mode), press the Turbo button, the super high fan speed is selected on Remote control and the indoor fan rotates at high speed.

### 11.1.6 Outdoor Fan Control

#### 11.1.6.1 OFAN Speed Type

The outdoor fan motor is DC motor with 10 defined speeds.

#### 11.1.6.2 General rules

1. The outdoor fan is ON when compressor ON during cooling, dring and heating mode.
2. When the unit is off by remote control, in safety stops and stop after reaching to the temperature point, the outdoor fan stops;
3. The outdoor fan is ON 30 sec ahead compressor start

4. Outdoor fan OFF will delay 60sec when compressor is OFF during cooling, dring and heating mode.

#### **11.1.6.3 OFAN control in cooling mode:**

If HPS2 is cut off (Pressure higher than 3.0Mpa), the OFAN will go to high fan speed. If the HPS2 is recovery (pressure is 2.4MPa), the OFAN speed will reduce by 1 speed until the pressure is reaching 3.0MPa.

This control is performed every 1 hour or pressure is below 2.4MPa.

#### **11.1.6.4 OFAN control in heating mode:**

OFAN will keep high fan speed

### **11.1.7 Refrigerant control**

#### **11.1.7.1 EEV is used for all model**

1. EEV operation after power-on: When power on, EEV will open 240steps and then move back with 540steps. This position will be recognized as 0. Then EEV will open to 480 steps and be ready for system operating.
2. EEV openloop depends on OAT,RAT,SPT and compressor frequency after compressor starts to operate.
3. Target CTT control will be performed after compressor operates for 5min.
4. The EEV opening will be updated every 5s.

### **11.1.8 Reversing Valve (RV) Control**

Reversing valve is on in heat mode.

RV ON will delay 10 sec when compressor is ON and Switching of RV state is done only after compressor is off for over 2 minutes.

## **11.2 Fan Mode**

In this mode, the indoor fan may run at high,medium,low and automatic speed. The compressor, outdoor fan and 4-way valve will be OFF.

In this mode, the range of setting temperature is 16~30C

## **11.3 Cool Mode**

If Load>0, the unit starts cooling operation. In this case, the compressor and outdoor fan will operate and the indoor fan will run at the setting speed.

If Load≤0, the compressor will stop operation and the outdoor fan will delay 60 seconds to stop.

While the indoor fan will run at the setting speed.

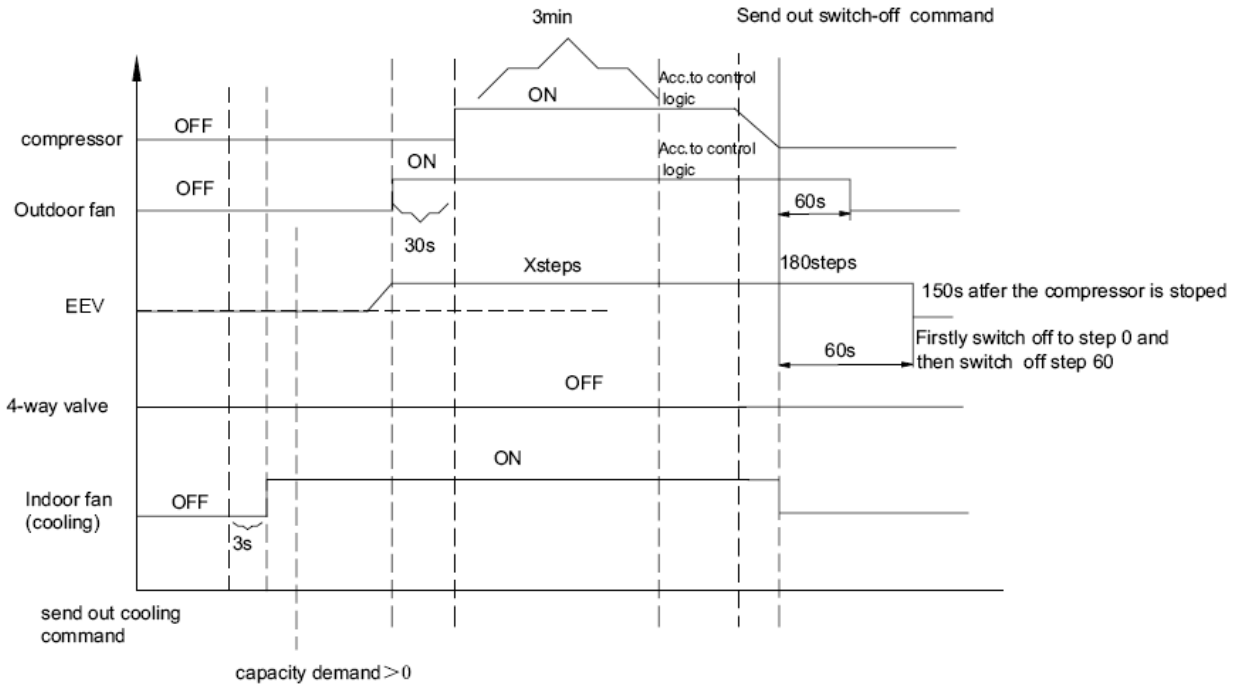

### 11.3.1 Indoor Fan operation under Cool Mode

The indoor fan will run at high speed for 5 seconds before it is put into operation according to the setting then run at the setting speed.

In Auto Fan user setting, fan speed will be adjusted automatically according to the SPT and RAT, refer to 11.1.5

### 11.4 Heat Mode

If Load > 0, the unit will operate in heating mode. The compressor, outdoor fan and 4-way valve will operate and the indoor fan will delay 1'30" to start at the latest

If LoadAT ≤ 0, the compressor will stop operation and the outdoor fan will delay 60 seconds to stop. And the indoor fan will blow for 60s at low fan speed for cassette and floor ceiling model and at setting fan speed for duct model. During this period, the fan speed can't be switched.

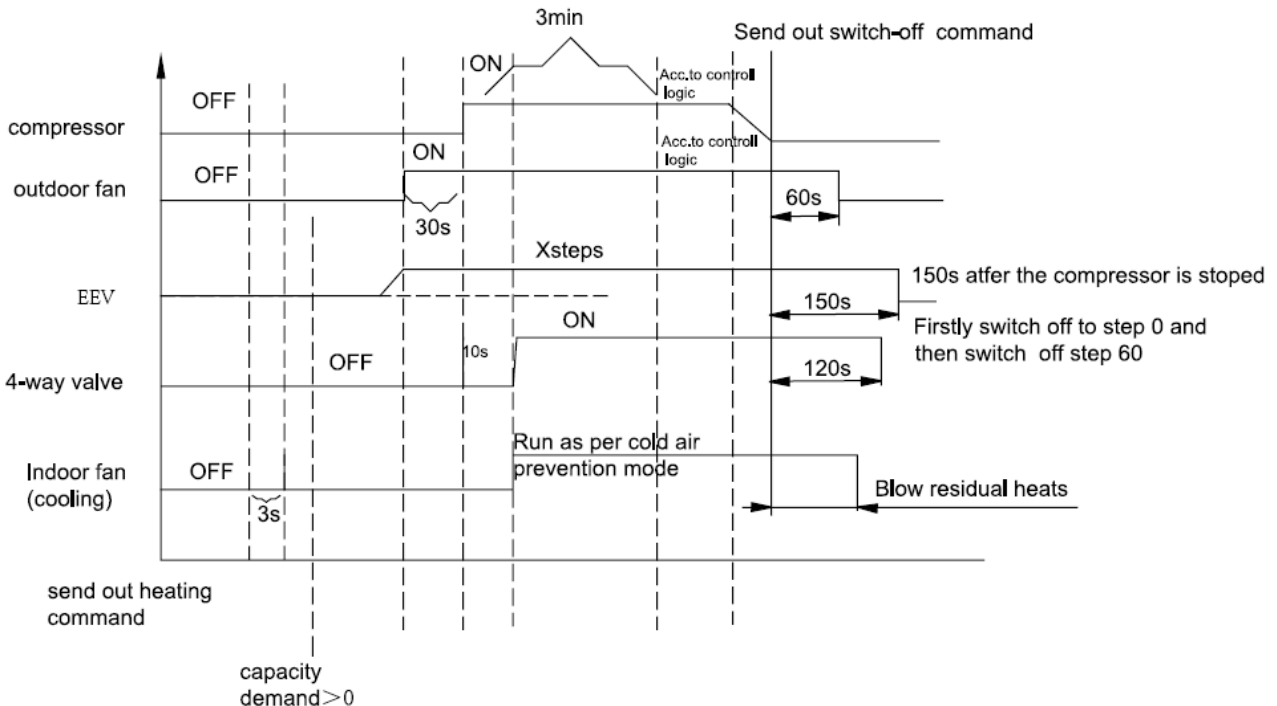

### 11.4.1 Indoor Fan Control in Heat Mode

Indoor fan speed depends on the indoor coil temperature

#### Anti-cold air function

When starting the heating mode, anti-cold air function will be activated and indoor fan can run at low speed or stop running. This function will terminate after the unit runs for 1.5min.

#### Residual heat blowing function

During heating, when the stopping condition for the compressor is reached. The indoor fan will blow for 60s at low fan speed for floor ceiling model and at setting fan speed for duct model. For cassette unit the indoor fan will operate continuously in low fan speed until compressor restarting.

During this period, the fan speed can't be switched.

For manual OFF condition, the residual heat blowing function will last 60s for all indoor models.

### 11.5 Auto Cool/Heat Mode

In AUTO mode, the system selects the running mode (COOL/HEAT/FAN) automatically according to the room temperature. The display shows the actual running mode and setting temperature.

There will be 30s delay for mode conversion.

1. When  $RAT \geq 26$  degree, the cooling mode is selected.
2. When  $RAT \leq 20$  degree, the unit runs in heating mode
3. When  $20 \text{ degree} < RAT < 26 \text{ degree}$ , upon initial startup, the unit will enter auto mode and run in automatic fan mode. If the other mode changes into auto mode, the previous running mode will remain.

### 11.6 Dry Mode

The dry mode is basically same as cooling mode. The difference is that:

- a) The indoor fan is fixed at low speed.
- b) Max. Capacity output:  $A \times 90\%$

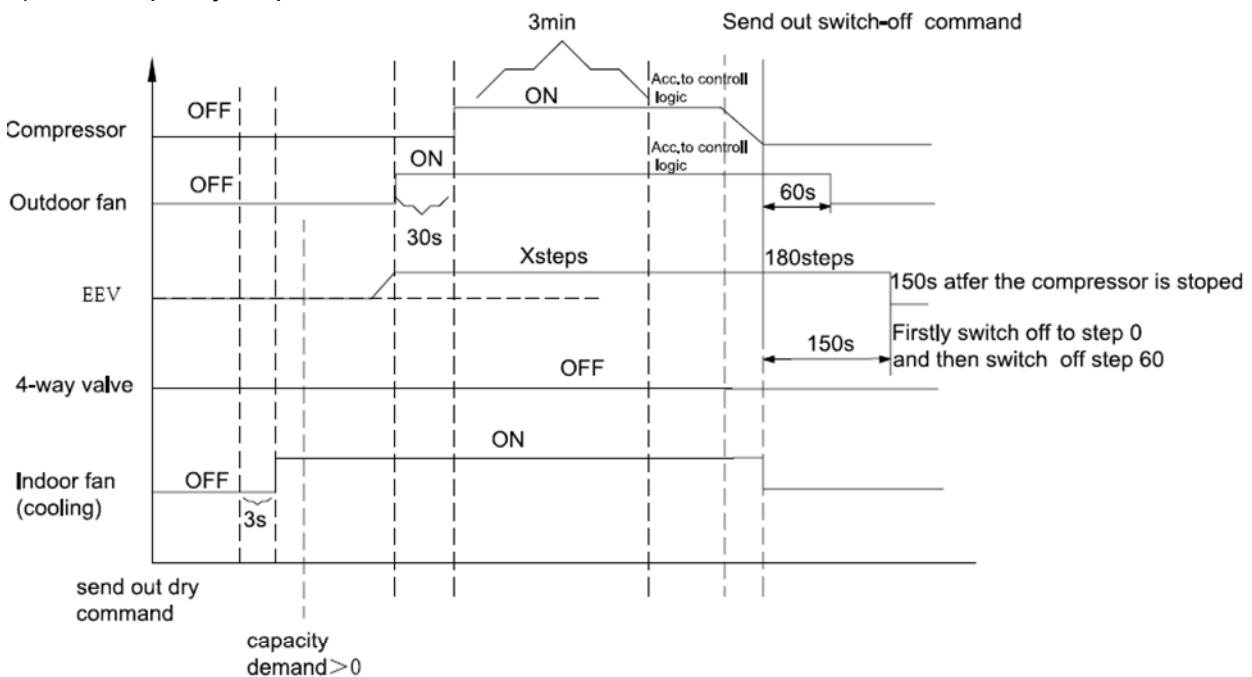

### 11.7 Oil return



When the unit is operating in low frequency for long time, the compressor will be forced to decrease frequency for 4 min to make sure the oil, which accumulated into the system, back to compressor.

During the oil return operation, the IDU has no any indication

## 11.8 Protections

There are 4 protection codes.

Normal (Norm) – unit operate normally.

Stop Rise (SR) – compressor frequency can not be raised but does not have to be decreased.

HzDown – Compressor frequency is reduced by 2Hz/s

Stop Compressor (SC) – Compressor is stopped.

### 11.8.1 Indoor Coil Defrost Protection

#### Conditions for Start Controlling

Judge the controlling start with the ICT (Indoor Coil Temperature) in cool and dry mode after compressor is on for 15min to allow the operating frequency limitation and then prevent freezing of the indoor heat exchanger.

Compressor will stop when  $ICT \leq ICT_{\text{defrost}}$  for continuous 3 mins, it can resume running automatically when  $ICT \geq 10$ .

Model	$ICT_{\text{defrost}}$
Duct	-2
Floor ceiling	-4
Cassette	-5

### 11.8.2 High Pressure Protection of Compressor by high pressure switch

When high pressure protection is detected for 3 seconds continuously, the high pressure switch is 4.2Mpa, the unit will stop and report the fault, it can not resume running automatically and display malfunction, it can resume by pressing ON/OFF.

### 11.8.3 Compressor over Heating Protection

If the discharge temperature rises above a certain level, the operating frequency upper limit is set to keep this temperature from going up further.

Compressor will stop when CTT reaches 130.

The unit can only resume running until the compressor has stopped for 3 minutes and the CTT is lower than 90°C

If the unit stops as such protection for 3 times, it can not resume running automatically and display malfunction, it can resume by pressing ON/OFF.

### 11.8.4 Compressor over Current Protection

Detect an input current by the CT during the compressor is running, and set the frequency upper limit from such input current. In case of heat pump model, this control is the upper limit control function of the frequency which takes priority of the lower limit of four way valve activating compensation.

Model	Current(A)
24	45

30	45
36	38
36T	11.5
42	11.5
48	14.5
60	14.5

**11.8.5 Outdoor Coil Deicing Protection**

This protection is for Heat Pump Only

This protection is carried out by the cooling cycle (reverse cycle). The defrosting time or outdoor heat exchanger temperature must be more than its setting values when finishing the deicing protection.

In the deicing protection, IFAN is forced OFF.

**11.8.5.1 Deicing Starting Conditions**

The starting conditions must be made with the outdoor air temperature (OAT) and outdoor coil temperature (OCT). Under the conditions that the system is in heating operation, after the time for defrosting is judged to be satisfied, if the temperature for deicing is satisfied after detections for continuous 3minutes, the deicing operation will start.

Deicing interval time is changed as a function of deicing time. If deicing time is shorter than former deicing time, the deicing interval time will be increased. If deicing time is longer than former deicing time, the deicing interval time will be decreased.

**11.8.5.2 Deicing Protection Procedure**

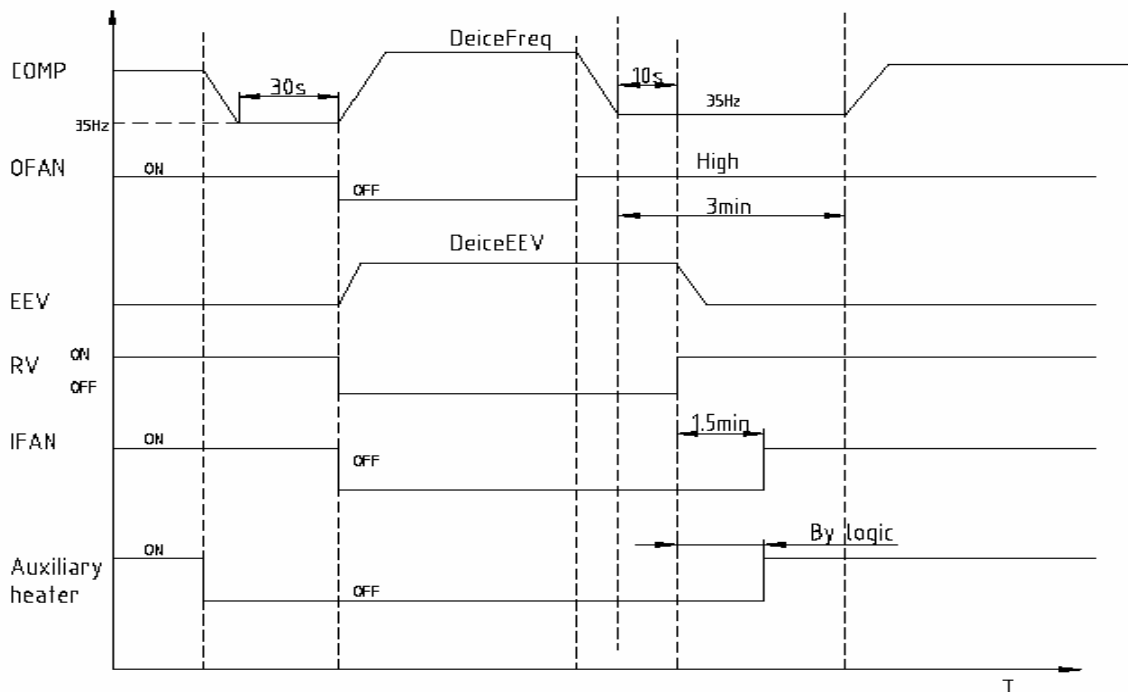

**11.8.5.3 Exiting Deicing**

The deicing operation can exit when any of the conditions below is satisfied:

1.  $OCT \geq 10^{\circ}C$
2.  $OCT \geq 6^{\circ}C$  lasts for more than 80s
3. The continuous running time of deicing reaches to 10min.

### 11.8.6 Condensate Water Over Flow Protection for cassette

Outdoor unit receives “overflow” signal from the indoor side. In cooling and dry mode, the pump is always on with the compressor on. And the pump will be on for 10 min after the compressor is off, in heating mode, the pump is off except that the overflow fault occurs.

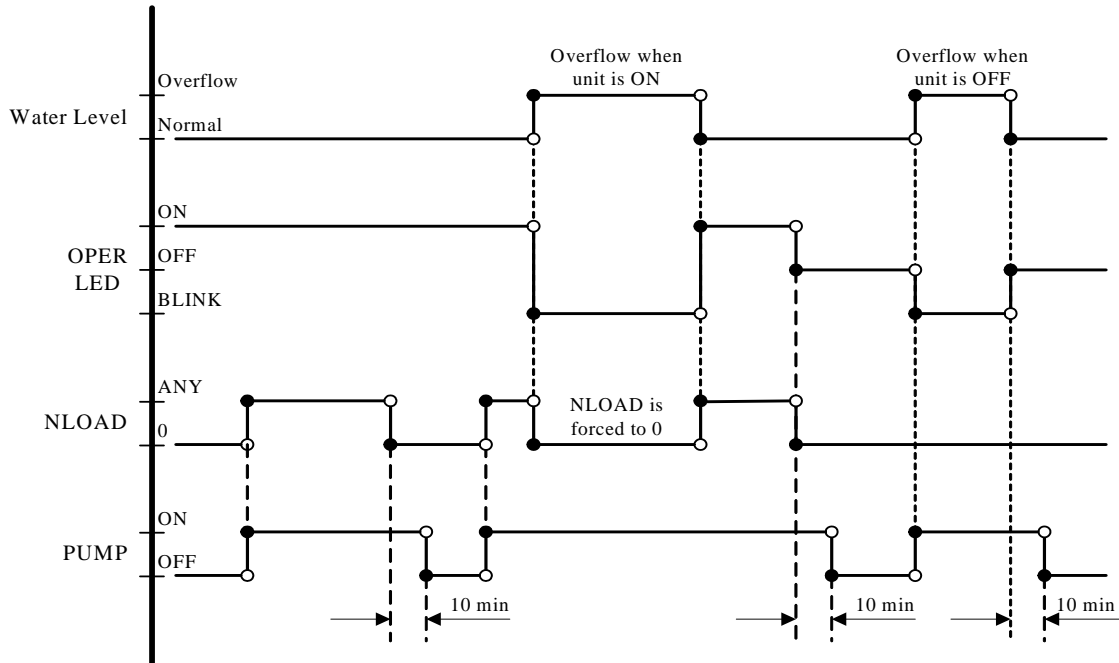

### 11.8.7 Communication malfunction

If the ODU does not receive correct signal from indoor unit for 30 seconds continuously, or if the indoor unit does not receive message from outdoor unit for 1 minute, the unit will stop as communication malfunction protection; if communication malfunction resume and compressor has stopped for 3min, the unit will resume running.

### 11.8.8 IPM module protection

When the compressor starts, if there is over current or control voltage low for IPM module as some abnormal results, IPM will detect module protection signal as the unit is on. Once the module protective signal is detected, stop the unit with module protection immediately. If the module protection is resumed and compressor has stopped for 3min, the unit will be allowed to operate.

If the module protection continuously occurs for 3 times, it should not be resumed automatically, and you should press the ON/OFF button to resume.

### 11.8.9 Module overheating protection

If the module temperature is higher than 100°C, the unit will stop. If module temperature is lower than 100°C, and compressor has stopped for 3min, the unit will resume operating. If the unit stops as module overheating protection for 6 times, it can not resume running automatically and display malfunction, it can resume by pressing ON/OFF.

### 11.8.10 Compressor overload protection

The Over Load Protector is used to detect the compressor's shell temperature. If the compressor temperature rises above a certain level, the compressor OLP will be cut off. Which will happen within 3 seconds continuously, the unit will stop and report fault. The unit will restart after 3 min if the fault is eliminated. If the unit stops as such protection for 3 times in 30 min, it can not resume running automatically and display malfunction, it can resume by pressing ON/OFF.

### 11.9 Operating the Unit from the ON/OFF Button

The ON/OFF button allows to operate the unit in AUTO mode, the microcomputer will monitor the room temperature and select the (COOL, HEAT, FAN) mode automatically, and temperature/Fan speed settings can not be changed.

### 11.10 Indoor Unit Controllers and Indicators

The following is schematic drawing for the display:

CAD:

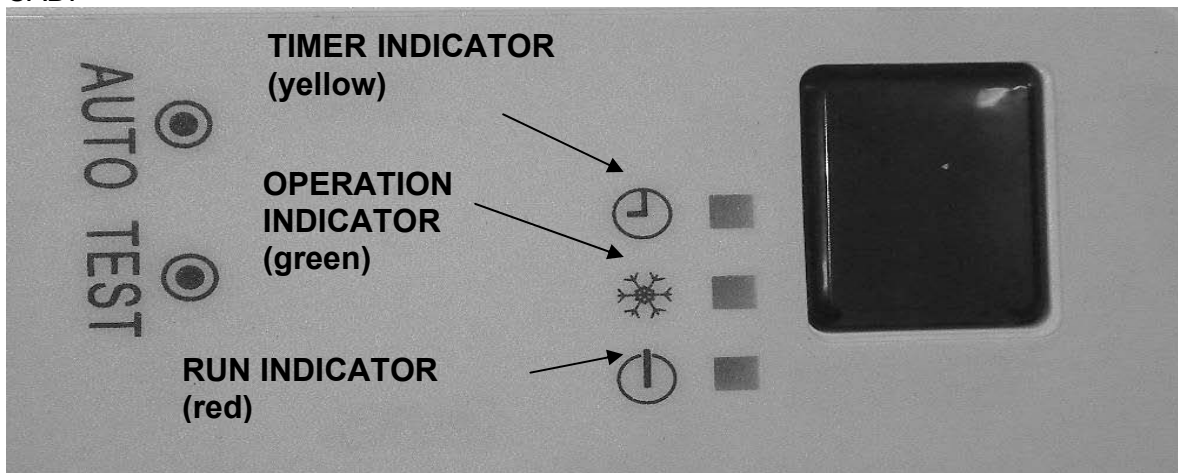

RUN INDICATOR	Lights up when the Air Conditioner is ON ,
OPERATION INDICATOR	Lights up when the compressor is ON.
TIMER INDICATOR	Lights up when the Timer is set
AUTO	Press the Auto button the unit will run auto mode automatically when the unit is off, Press the AUTO button, the air conditioner will stop when it is on
TEST	When pressing it, the air conditioner will be forced to operate or stop. Do not press it when air conditioner is in normal operation.

FAD:



POWER	Lights up when the unit is connected to power
COOL	Lights up when the unit is running in cooling mode
HEAT	Lights up when the unit is running in heat mode
Timer icon	Lights up when the timer is set

### 11.11 Forced Mode (Compulsory operating function).

Entering into forced mode :

After the unit is powered for 5mins, press the light button on remote controller for 3 times in 3s successively to enter into Freon recovery mode. Fo will be displayed. When Freon recovery mode operated for 25mins, all loads will operate in cooling mode. (The setting fan speed is high fan speed and the setting temperature is 16C )

Exiting forced mode:

Any signal from remote controller or button will exit the forced mode, and then the unit will operate at the current setting command.

Forced mode will also be exited after operating for 25mins and then the unit will be turned off.

### 11.12 Characteristics of sensor

#### 11.12.1 RAT/OAT

RAT/OAT R-T chart

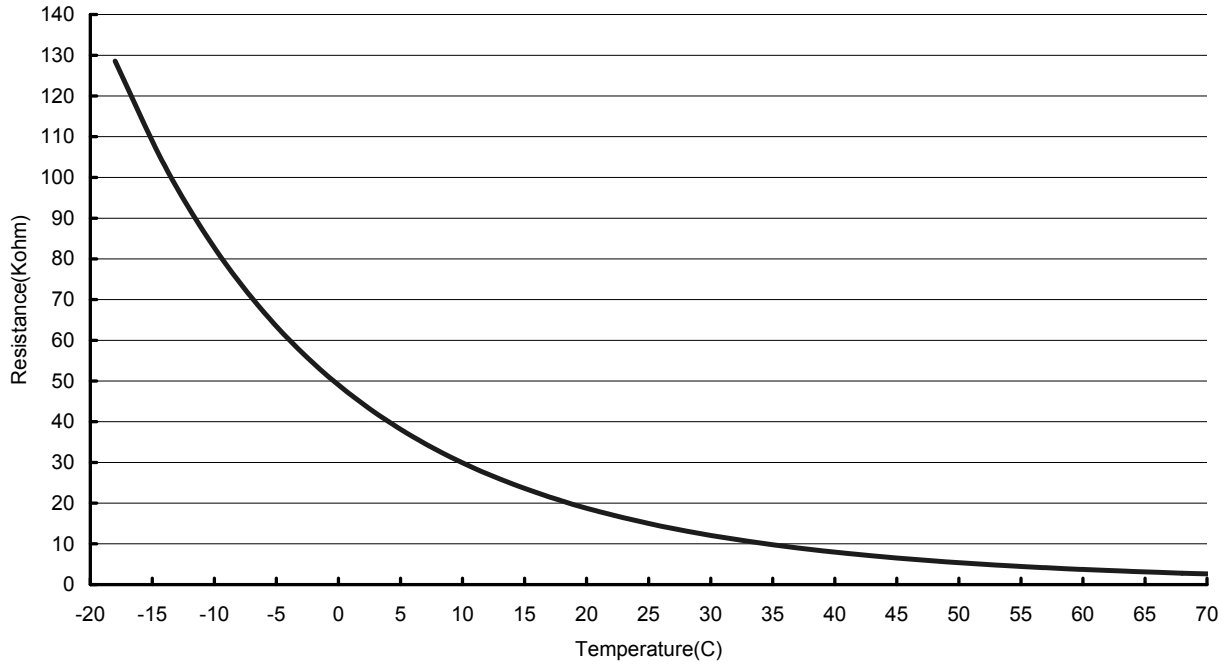

#### 11.12.2 ICT/OCT

ICT/OCT R-T Chart

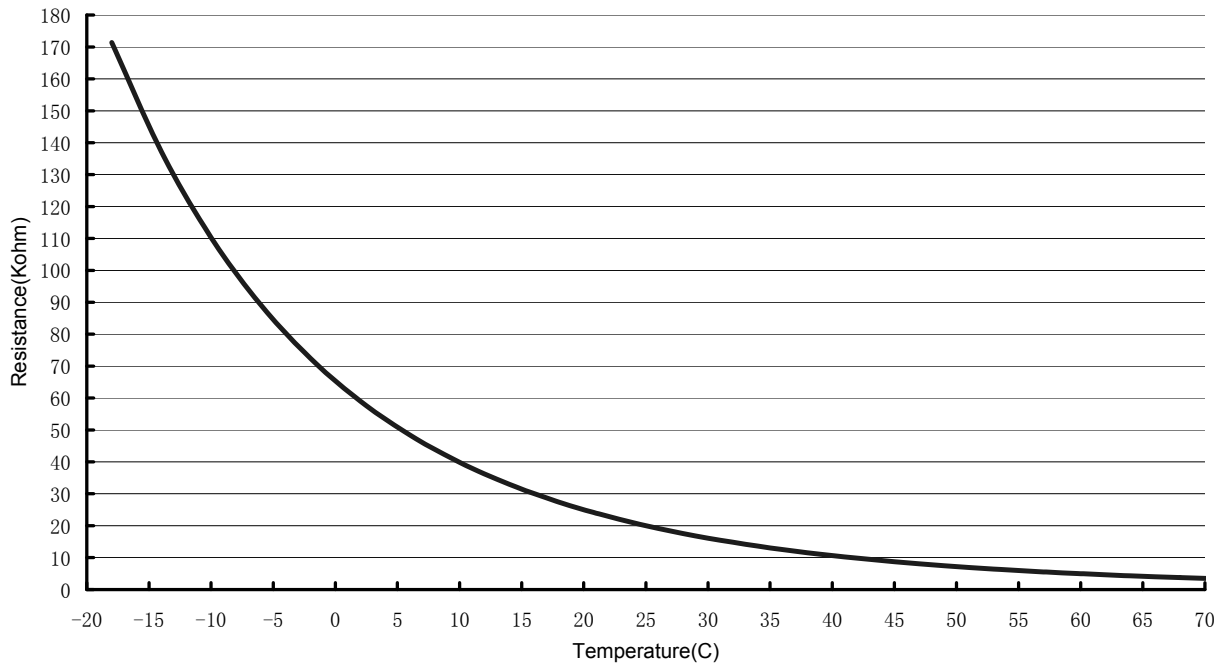

11.12.3 CTT

CTT R-T Chart

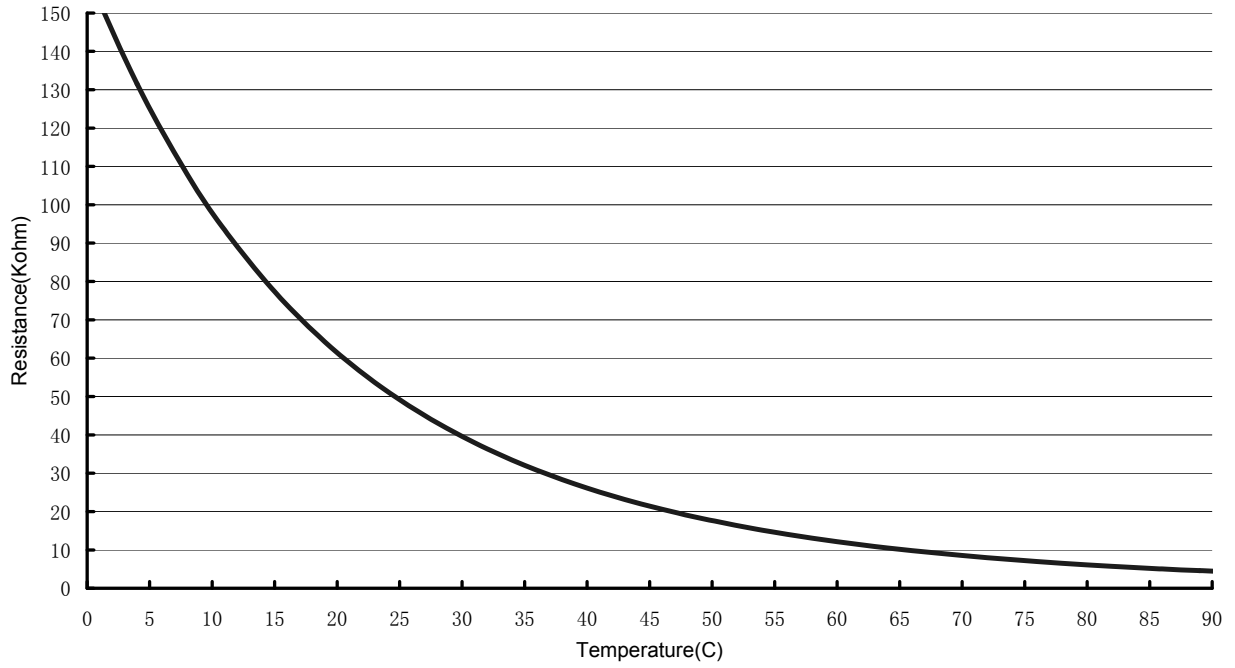

## 12. TROUBLESHOOTING

### 12.1 ELECTRICAL & CONTROL TROUBLESHOOTING

#### 12.1.1 Precautions before Performing Inspection or Repair

Be cautious during installation and maintenance. Do operation following the regulations to avoid electric shock and casualty or even death due to drop from high attitude.

\* **Static maintenance** is the maintenance during de-energization of the air conditioner. For static maintenance, make sure that the unit is de-energized and the plug is disconnected.

\* **Dynamic maintenance** is the maintenance during energization of the unit. Before dynamic maintenance, check the electricity and ensure that there is ground wire on the site. Check if there is electricity on the housing and connection copper pipe of the air conditioner with voltage tester. After ensure insulation place and the safety, the maintenance can be performed.

Take sufficient care to avoid directly touching any of the circuit parts without first turning off the power. At time such as when the circuit board is to be replaced, place the circuit board assembly in a vertical position. Normally, diagnose troubles according to the trouble diagnosis procedure as described below. (Refer to the check points in servicing written on the wiring diagrams attached to the indoor/outdoor units.)

#### **Precautions when inspecting the control section of the outdoor unit:**

A large-capacity electrolytic capacitor is used in the outdoor unit controller (inverter). Therefore, if the power supply is turned off, charge (charging voltage DC280V to 380V) remains and discharging takes a lot of time. After turning off the power source, if touching the charging section before discharging, an electrical shock may be caused.

The outdoor unit can not be started up until the unit is de-energized for 20min

#### 12.1.2 Confirmation

12.1.2.1 Confirmation of Power Supply Confirm that the power breaker operates (ON) normally;

12.1.2.2 Confirmation of Power Voltage Confirm that power voltage is AC220~240V +/- 10% for single phase and AC380-415V +/- 10% for three phase. If power voltage is not in this range, the unit may not operate normally.



### 12.1.3 Judgment by Indoor/Outdoor Unit Diagnostics

The error code will be directly displayed through indoor display and wired controller.

#### 12.1.3.1 Indoor Unit Diagnostics

Error code	Malfunction
E0	Water Pump failure
E1	High-pressure switch protection
E2	Defrost protection
E3	Low-pressure switch protection
E4	Compressor over heating protection
E5	Compressor overload protection
E6	Communication malfunction
E9	Water overflow protection
F0	RAT failure
F1	ICT failure
F2	OCT failure
F3	OAT failure
F4	CTT failure
F5	RCT failure

#### 12.1.3.2 Indoor Unit Diagnostics and Corrective Actions

Indoor indicators		Failure	Possible Reasons/Corrective actions
2* 7 segments	LEDs (Cassette) (Timer, Oper, RUN)		
E0		Water pump failure	<ul style="list-style-type: none"> <li>● Connection of pump is loosen</li> <li>● Pump is damaged</li> </ul>
E1	Oper LED blink 3 times	High-pressure switch protection	<ul style="list-style-type: none"> <li>● Refrigerant was superabundant</li> <li>● Poor heat exchange (including blockage and bad radiating environment )</li> <li>● Too high ambient temperature</li> </ul>
E2	Run LED blink 3 times	Defrost protection	<ul style="list-style-type: none"> <li>● Poor air-return in indoor unit</li> <li>● Fan speed is abnormal</li> <li>● Evaporator is dirty.</li> <li>● The ambient temperature is too low</li> </ul>
E3	Oper LED blink 4 times	Low pressure switch protection	<ul style="list-style-type: none"> <li>● Refrigerant leakage</li> <li>● Poor heat exchange (including blockage and bad radiating environment )</li> <li>● EEV connection problem or damage</li> </ul>
E4	Oper LED blink 6 times	Compressor over heating protection	<ul style="list-style-type: none"> <li>● EEV connection problem or damage</li> <li>● Refrigerant leakage</li> <li>● Poor heat exchange</li> </ul>
E5	Oper LED blink 5 times	Compressor overload protection	<ul style="list-style-type: none"> <li>● Connection of compressor OLP is loosen (the resistance for this terminal should be less than 1ohm)</li> <li>● EEV connection problem or damaged/Capillary problem</li> <li>● Refrigerant leakage</li> </ul>
E6	Run LED blink 1 times	Communication malfunction	<ul style="list-style-type: none"> <li>● Wiring mistakes</li> <li>● IDU or ODU PCB problem</li> </ul>
E9	Run LED blink 2 times	Water overflow protection	<ul style="list-style-type: none"> <li>● Pump is damaged</li> <li>● The drain pipe is block</li> </ul>
F0	Timer LED blink 1 time	RAT failure	<ul style="list-style-type: none"> <li>● Senor was broken or damaged</li> <li>● PCB temperature detection circuit has problem</li> </ul>
F1	Timer LED blink 2 time	ICT failure	
F2	Timer LED blink 3 time	OCT failure	
F3	Timer LED blink 4 time	OAT failure	
F4	Timer LED blink 5 time	CTT failure	
F5		RCT failure	

## 12.1.3.3 Outdoor Unit Diagnostics

Malfunction Item	Outdoor unit display of dual 8 numeral tube	Indoor Unit Display
DC over voltage protection	PH	E5
Heat sink overheating protection	P8	E5
Current sensor failure	Pc	E5
HST failure	P7	E5
Compressor phase current detection problem	P5	E5
DC under voltage protection	PL	E5
Compressor startup failure	Lc	E5
PFC protection	Hc	E5
Compressor lock	LE	E5
IPM Reset	P0	E5
Desynchronizing of compressor	H7	E5
Lack phase protection of compressor	Ld	E5
Communication malfunction between driver and main controller	P6	E5
IPM protection	H5	E5
Compressor over speed	LF	E5
Sensor connection protection	Pd	E5
Temperature shift protection	PE	E5
AC contactor protection	P9	E5
High-pressure switch protection	E1	E1
Low-pressure switch protection	E3	E3
Compressor over heating protection	E4	E4
Compressor overload protection	H3	E5
Communication malfunction (among indoor unit, outdoor unit and wired controller)	E6	E6
OAT failure	F3	F3
OCT failure	F2	F2
CTT failure	F4	F4
Deicing(non-malfunction)	8	Deicing
Oil return (non-malfunction)	9	no display
Mismatch between IDU and ODU	LP	no display
AC over current protection	PA	E5
Driver board ambient temperature sensor failure	PF	E5
AC under voltage/AC over voltage *	PP	E5
Charging malfunction of capacitor *	PU	E5

## 12.1.3.4 Outdoor Unit Diagnostics and Corrective Actions

Indoor indicators	ODU indicators	Failure	Possible Reasons/Corrective actions
E5	PH	DC over voltage protection	<ul style="list-style-type: none"> <li>● AC power supply is higher than 265V</li> <li>● Outdoor PCB circuit malfunction</li> </ul>
E5	P8	Heat sink overheating protection	<ul style="list-style-type: none"> <li>● Insufficient grease on heatsink or poor connection of heatsink to PCB</li> <li>● Outdoor PCB problem.</li> </ul>
E5	Pc	Current sensor failure	PCB is damaged
E5	P7	HST failure	PCB is damaged
E5	P5	Compressor phase current detection problem	Phase current detection circuit for compressor has problem.
E5	PL	DC under voltage protection	<ul style="list-style-type: none"> <li>● AC power supply voltage is less than 150VAC</li> <li>● Outdoor PCB circuit malfunction</li> </ul>
E5	Lc	Compressor startup failure	<ul style="list-style-type: none"> <li>● Compressor wiring mistake</li> <li>● Over charged system</li> <li>● System not balanced before compressor starting</li> <li>● Compressor problem</li> </ul>
E5	Hc	PFC protection	<ul style="list-style-type: none"> <li>● PFC module assembly problem.</li> <li>● Poor heat exchange of Heatsink</li> <li>● PFC reactor problem.</li> <li>● Abnormal power voltage</li> <li>● PFC circuit problem on PCB</li> </ul>
E5	LE	Compressor lock	<ul style="list-style-type: none"> <li>● Compressor wiring mistake</li> <li>● Over charged system</li> <li>● System not balanced before compressor starting</li> <li>● Compressor problem</li> </ul>
E5	P0	IPM reset	
E5	H7	Desynchronizing of compressor	<ul style="list-style-type: none"> <li>● Abnormal power input voltage.</li> <li>● Compressor wiring mistake.</li> <li>● Liquid and gas valve are not open.</li> <li>● EEV damaged or not proper working</li> <li>● Poor heat exchange.</li> <li>● Over charged system.</li> </ul>
E5	Ld	Lack phase protection of compressor	<ul style="list-style-type: none"> <li>● Phase current detection circuit for compressor has problem.</li> <li>● Comp wiring mistake</li> </ul>
E5	P6	Communication malfunction between driver and main controller	<ul style="list-style-type: none"> <li>● Wiring mistakes</li> <li>● ODU PCB problem</li> </ul>
E5	H5	IPM protection	<ul style="list-style-type: none"> <li>● Abnormal power input voltage.</li> <li>● Compressor wiring mistake.</li> <li>● Liquid and gas valve are not open.</li> <li>● EEV damaged or not proper working</li> <li>● Poor heat exchange.</li> <li>● Over charged system.</li> </ul>
E5	LF	Compressor over speed	
E5	Pd	Sensor connection protection	<ul style="list-style-type: none"> <li>● Compressor wiring mistake</li> <li>● The compressor wire go cross the relative current sensor</li> <li>● IPM damage</li> </ul>
E5	PE	Temperature shift protection	
E5	P9	AC contactor protection	
E1	E1	High-pressure switch protection	<ul style="list-style-type: none"> <li>● Refrigerant was superabundant</li> <li>● Poor heat exchange (including blockage and bad radiating environment )</li> <li>● Too high ambient temperature</li> </ul>
E3	E3	Low-pressure switch protection	<ul style="list-style-type: none"> <li>● Refrigerant leakage</li> <li>● Poor heat exchange (including blockage and bad radiating environment )</li> <li>● EEV connection problem or damage</li> </ul>
E4	E4	Compressor over heating protection	<ul style="list-style-type: none"> <li>● EEV connection problem or damage</li> <li>● Refrigerant leakage</li> <li>● Poor heat exchange</li> </ul>

E5	H3	Compressor over load protection	<ul style="list-style-type: none"> <li>● Connection of compressor OLP is loosen (the resistance for this terminal should be less than 1ohm)</li> <li>● EEV connection problem or damaged/Capillary problem</li> <li>● Refrigerant leakage</li> </ul>
E6	E6	Communication malfunction	<ul style="list-style-type: none"> <li>● Wiring mistakes</li> <li>● IDU or ODU PCB problem</li> </ul>
F3	F3	OAT failure	<ul style="list-style-type: none"> <li>● Sensor was broken or damaged</li> <li>● PCB temperature detection circuit has problem</li> </ul>
F2	F2	OCT failure	
F4	F4	CTT failure	
	08	Deicing	Normal function during heating
	09	Oil return	Normal function
	LP	Mismatch between IDU and ODU	<ul style="list-style-type: none"> <li>● Wiring mistakes</li> <li>● IDU or ODU PCB problem</li> <li>● IDU jumper setting is wrong</li> </ul>
E5	PA	AC over current protection	<ul style="list-style-type: none"> <li>● Supply voltage is unstable</li> <li>● Supply voltage is too low and load is too high</li> </ul>
E5	PF	Driver board ambient temperature sensor failure	
E5	PP	AC under voltage/ AC over voltage	<ul style="list-style-type: none"> <li>● Supply voltage is unstable</li> <li>● PCB is damaged</li> </ul>
E5	PU	Charging malfunction of capacitor	<ul style="list-style-type: none"> <li>● Reactor open</li> <li>● Charging relay or other components damaged on PCB.</li> </ul>

### 12.1.4 Checking the refrigeration system

Checking system pressures and other thermodynamic measures should be done when system is in Test Mode (in Test mode, system operates in fixed settings). The performance curves given in this manual are given for unit performance in test mode when high indoor fan speed is selected.

Entering test mode please refer to section 11- Control system.

## 12.2 Simple procedures for checking the Main Parts

### 12.2.1 Checking Mains Voltage.

Confirm that the Mains voltage is between 198 and 264 VAC. If Mains voltage is out of this range, abnormal operation of the system is expected. If in range check the Power (Circuit) Breaker and look for broken or loosed cable lugs or wiring mistake(s).

### 12.2.2 Checking Power Input.

If Indoor unit power LED is unlighted, power down the system and check the fuse of the Indoor unit. If the fuse is OK replace the Indoor unit controller. If the fuse has blown, replace the fuse and power up again.

Checking Power Input procedure for the Outdoor unit is the same as with the Indoor unit.

### 12.2.3 Checking the Outdoor Fan Motor.

Check the output voltage between two wires (RED and BLACK) of connector Controller DC-MOTOR, normal voltage is 310VDC.

### 12.2.4 Checking the Compressor.

The compressor is brushless permanence magnetic DC motor. Three coil resistance is same. Check the resistance between three poles. The normal value should be below 0.7 ohm.

### 12.2.5 Checking the Reverse Valve (RV).

Running in heating mode, check the voltage between two pins of reverse valve connector, normal voltage is 220~240VAC.

**13. EXPLODED VIEWS AND SPARE PART LISTS**

**13.1 Exploded view of Indoor unit: DBD024**

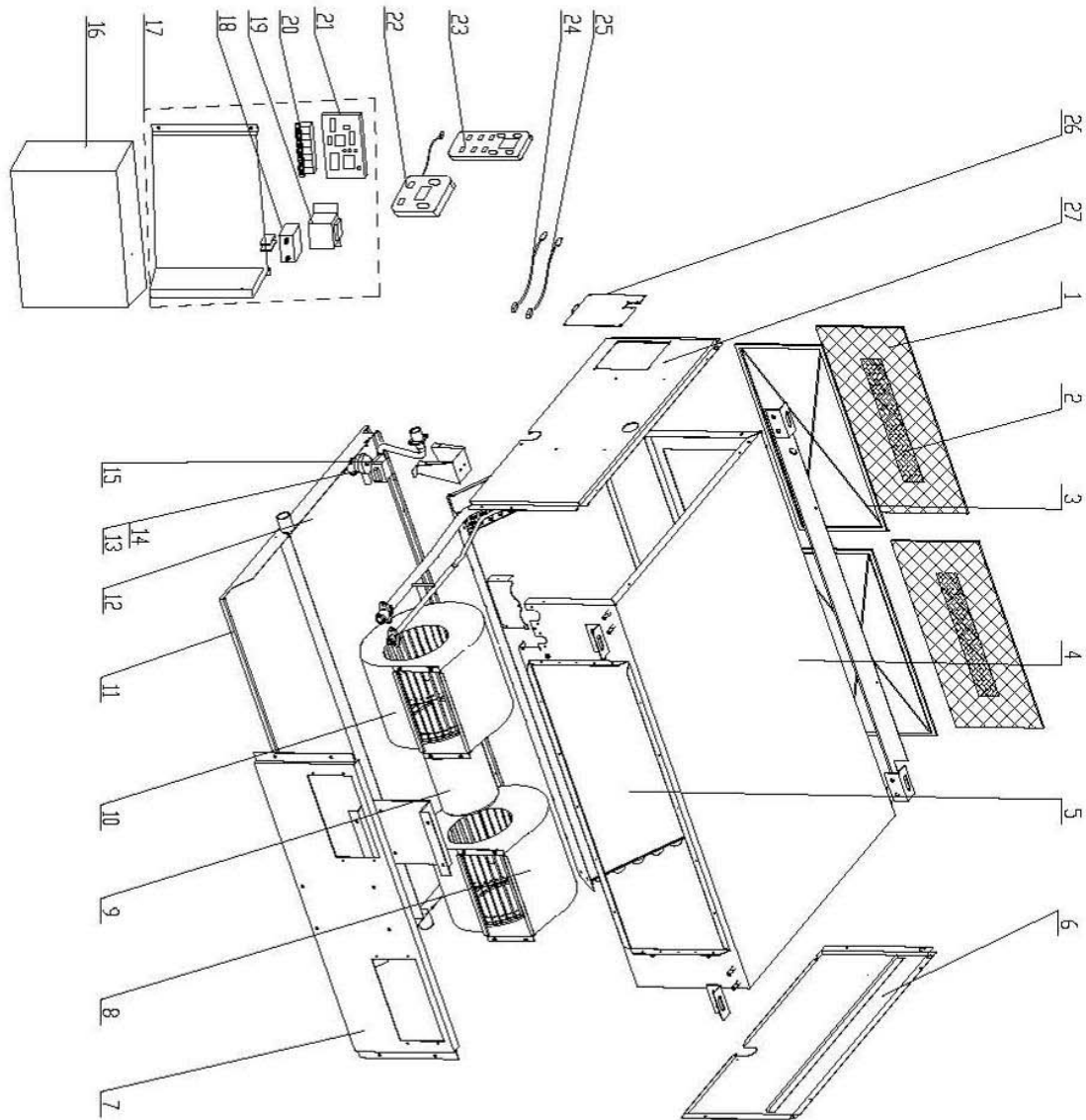

### 13.2 Spare part list of Indoor Unit: DBD024

NO.	Part Code	Part Description	qty
1	11125304	Filter	2
2	111200515	Filter	2
3	11125303	Filter Sub-assy	2
4	01265301	Top Cover	1
5	01025301	Evaporator Assy	1
6	01315304	Right Side Plate	1
7	01325301	Fan Fixed Plate	1
8	15012454	Motor(left) SYP-160/200J	1
9	15705304	Fan motor	1
10	15012458	Motor(right) SYP-160/200J	1
11	01265304	Bottom Cover	1
12	01285317	Water Tray Foam	1
13	none	Water Pump	0
14	none	Water Pump Assy	0
15	305050031		
16	01425269	Electric Box Cover	1
17	01395777	Electric Box Assy	1
18	33010014	Capacitor	1
19	43110239	Transformer	1
20	42010194	Terminal Board	1
21	30228205	Main PCB2 Z8235	1
22	30294219	Display Board	1
23	30510460	Remote controller YX1F1	1
24	3900012128G	Tube sensor	1
25	3900012123G	Temperature Sensor	1
26	01495304	Seal of Connection Pipe	1
27	01315293	Left Side Plate Assy	1
	76712455	Corrugated Pipe $\phi$ 16	2
	05010051	Choke Plug of Drain Pipe	1

13.3 Exploded view of Indoor unit: DBD024-060

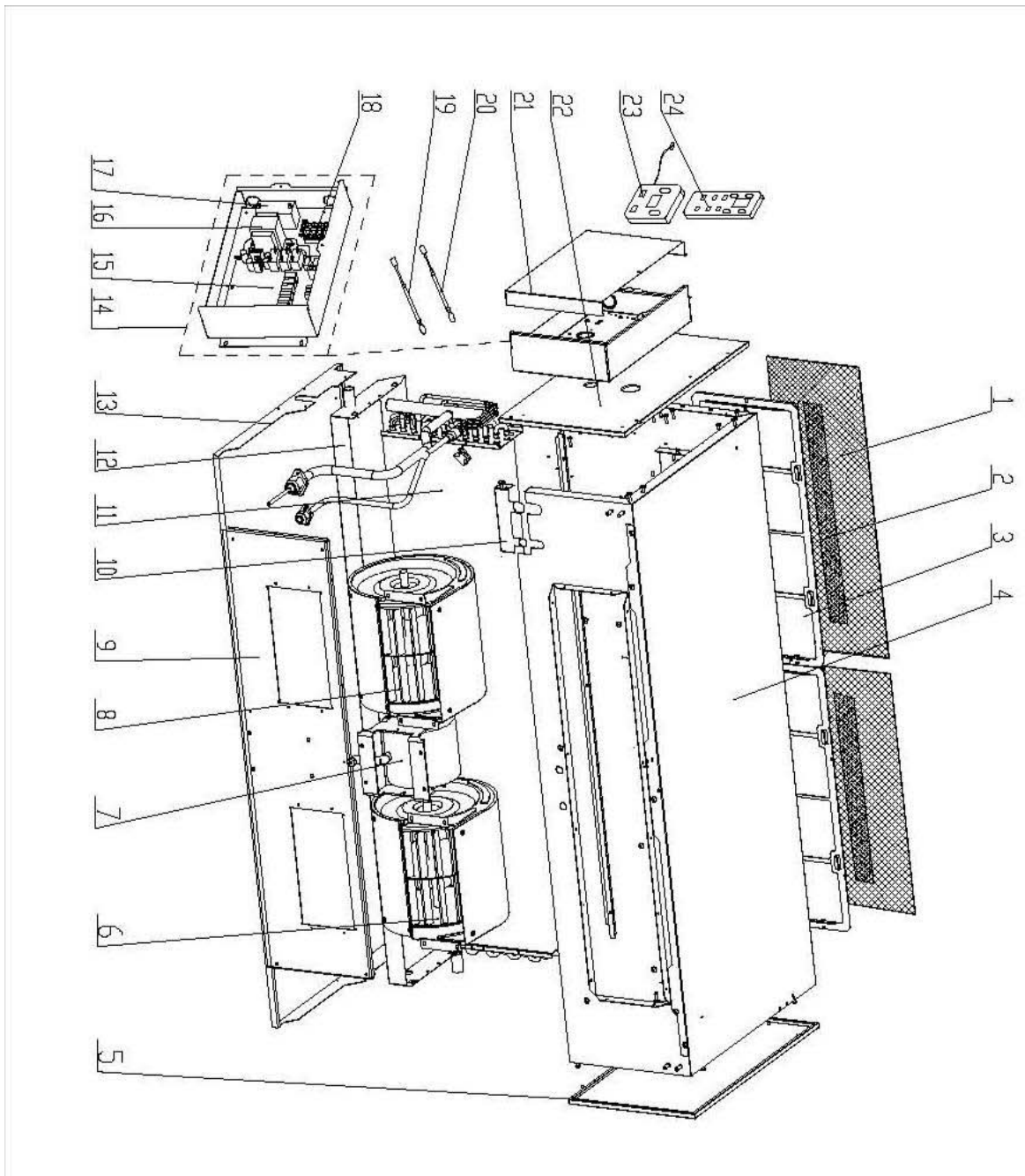

### 13.4 Spare part list of Indoor Unit: DBD030

NO.	Part Code	Part Description	qty
1	11125304	Filter	2
2	111200515	Filter	2
3	11125303	Filter Sub-assy	2
4	01265301	Top Cover	1
5	01315293	Left Side Plate Assy	1
6	15012454	Motor(left) SYP-160/200J	1
7	15705304	Fan motor	1
8	15012458	Motor(right) SYP-160/200J	1
9	01325301	Fan Fixed Plate	1
10	01495304	Seal of Connection Pipe	1
11	01025387	Evaporator Assy	1
12	01285317	Water Tray Foam	1
13	01265304	Bottom Cover	1
14	01395777	Electric Box Assy	1
15	30228205	Main PCB2 Z8235	1
16	43110239	Transformer	1
17	33010014	Capacitor	1
18	42010194	Terminal Board	1
19	3900012128G	Tube sensor	1
20	3900012123G	Temperature Sensor	1
21	01425269	Electric Box Cover	1
22	01315304	Right Side Plate	1
23	30294219	Display Board	1
24	30510460	Remote controller YX1F1	1
	76712455	Choke Plug of Drain Pipe	2
	05010051	Corrugated Pipe $\phi$ 16	2



13.5 Exploded view of Indoor unit: DBD036

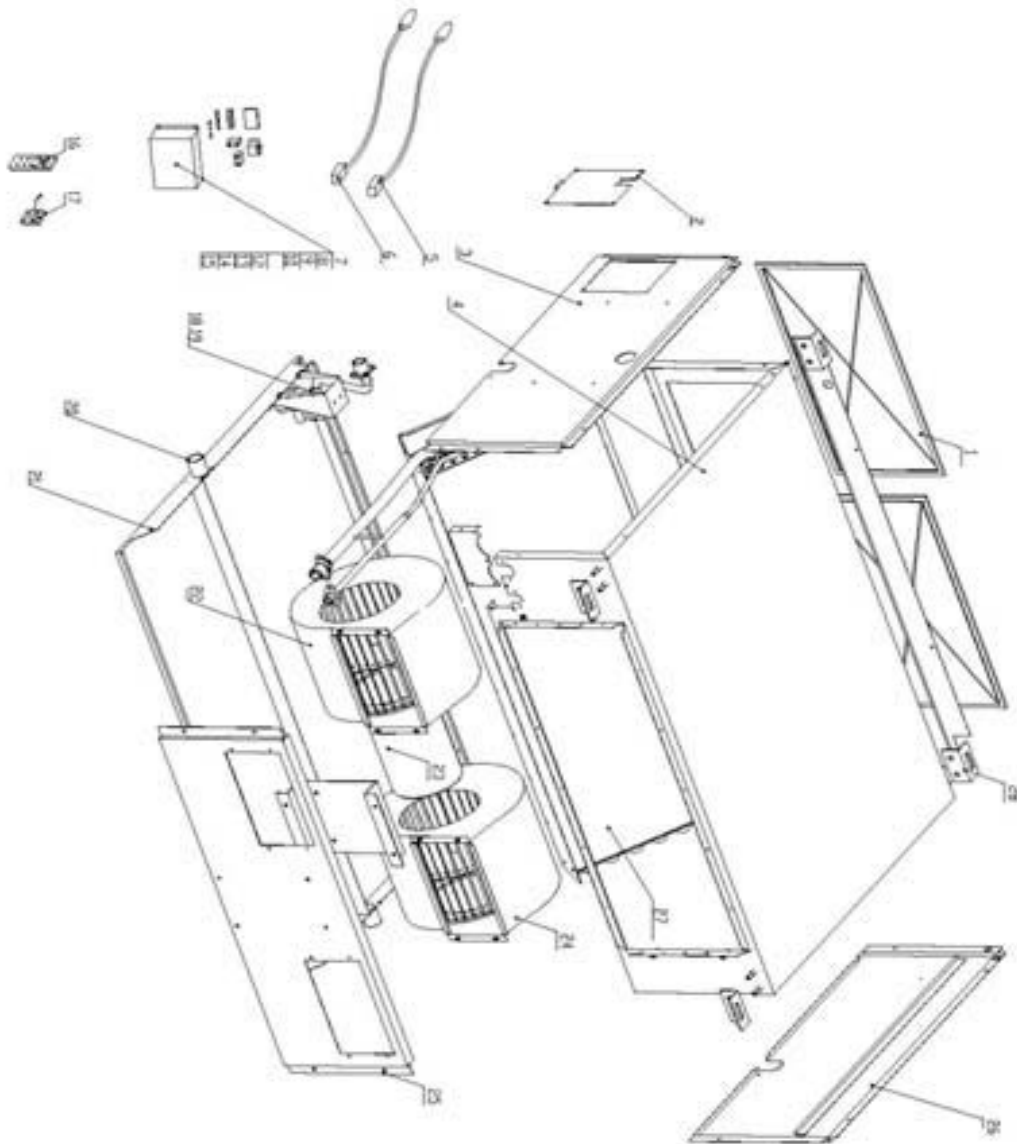

### 13.6 Spare part list of Indoor Unit: DBD036

NO.	Part Code	Part Description	qty
1	111253031	air filter	2
2	01495306	Seal of Connection Pipe	1
3	01315306	Left Side Plate	1
4	01265306	Top Cover	1
5	3900012123	Temperature Sensor (15K black)	1
6	390001921	Tube Sensor (20K black)	1
7	01395776	Electric Box Assy	1
8	30228205	Main PCB2 Z8235	1
9	43110239	Transformer	1
10	33010734	Capacitor	1
12	42011103	Terminal Board 2-8	3
13	42010194	Terminal Board	1
14	70410523	Isolation Washer	1
15	71010102	Fixed Clamp	2
16	30510460	Remote controller YX1F1	1
17	30294219	Display Board	1
18	450127011	Water Level Switch	1
19	15405302	Water Pump Assy	1
20	01285323	Water Tray Components	1
21	15265301	Bottom Cover	1
22	15018604	Motor	1
23	15705305	Fan Motor	1
24	15018603	Motor	1
25	01325220	Fixing Plate Sub-assy	1
26	01315341	Right Side Plate Sub-Assy	1
27	01025358	Evaporator Assy	1
28	02112466	Hook	4
	01425269	Sensor Insert	1
	42020063	Filter	2
	11125304	Side Plate of Air intake	1
	01375301	Choke Plug of Drain Pipe	2
	05010051	Electric Box Cover	1
	111200515	Corrugated Pipe $\phi$ 16	2
	45020054	Dial Switch	1
	76712455	Filter	2

13.7 Exploded view of Indoor unit: DBD060

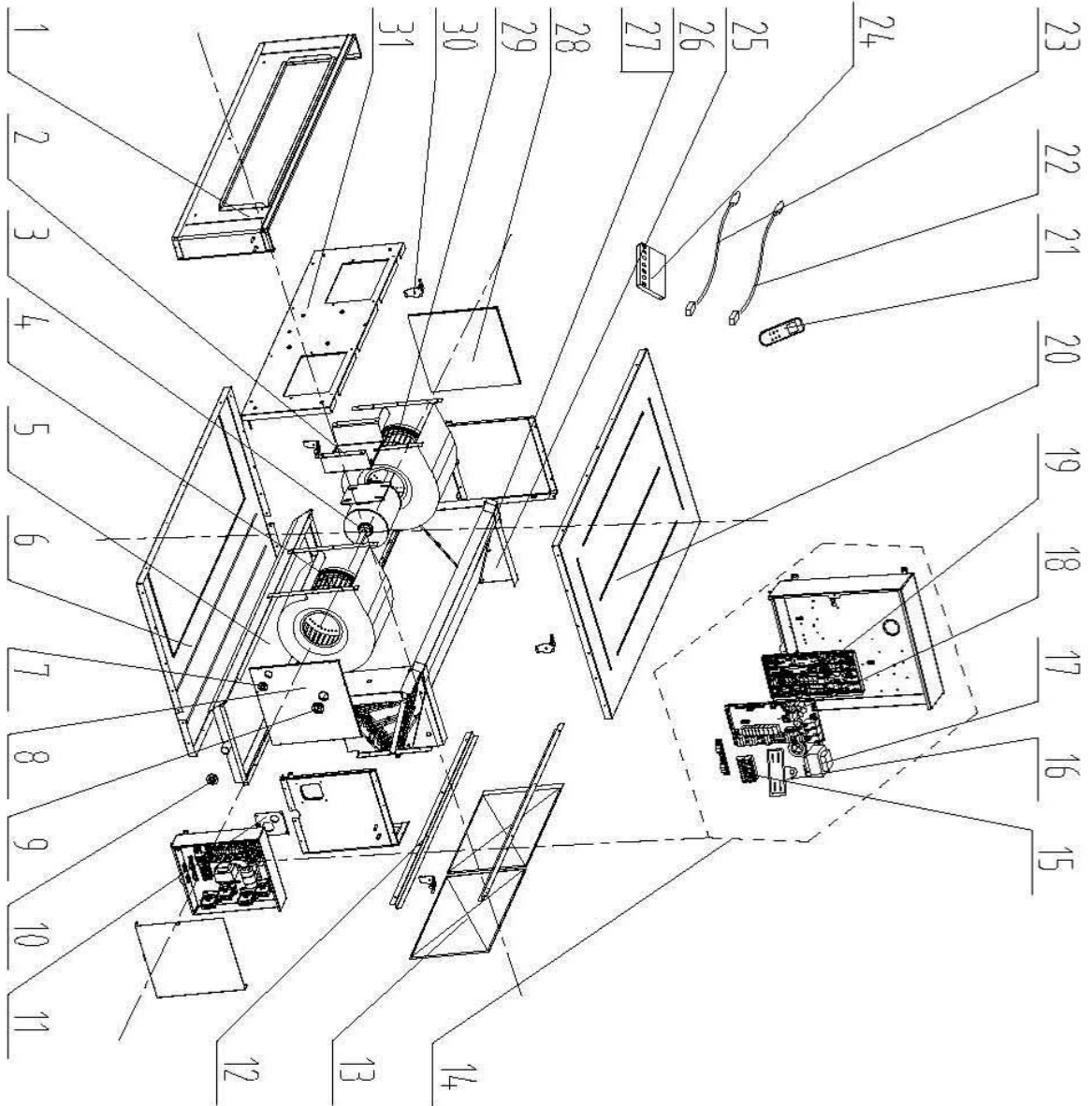

### 13.8 Spare part list of Indoor Unit: DBD060

NO.	Part Code	Part Description	qty
1	01315374	Front Side Plate Sub-Assy	1
2	01804715	Motor Support Sub-Assy	1
3	1570523001	Fan Motor	1
4	15705306	Fan motor (Left type)	1
5	01285283	Water tray assy	1
6	01265357	Lower cover plate assy	1
7	76510021	Cable-Cross Loop	1
8	01315378	Right Side Plate Sub-Assy 2	1
9	76515202	Cable-Cross Loop	1
10	76712454	Choke Plug of Water Pipe	1
11	01495241	Seal plate sub-assy(connection pipe)	1
12	02285220	Guide slot (filter)	2
13	11725211	Filter sub-assy	2
14	01395970	Electric Box Assy	1
15	42010194	Terminal Board	1
16	3301074709	Capacitor CBB61	1
17	43110239	Transformer	1
18	30228205	Main PCB2 Z8235	1
19	01845221	Electrical Retaining Plate	1
20	01265359	Upper cover plate assy	1
21	30510460	Remote controller YX1F1	1
22	39000208	Temperature Sensor	1
23	3900012128G	Tube sensor	1
24	30294219	Display Board	1
25	01345218	Sealing plate 1	1
26	01025405	Evaporator Assy	1
27	01025404	Evaporator Assy	1
28	01315376	Left Side Plate Sub-assy	1
29	15705307	Fan motor (right type)	1
30	02112466	Hook	4
31	01324259	Fan Mounting Plate Assy	1

13.9 Exploded view of Indoor unit:CAD024

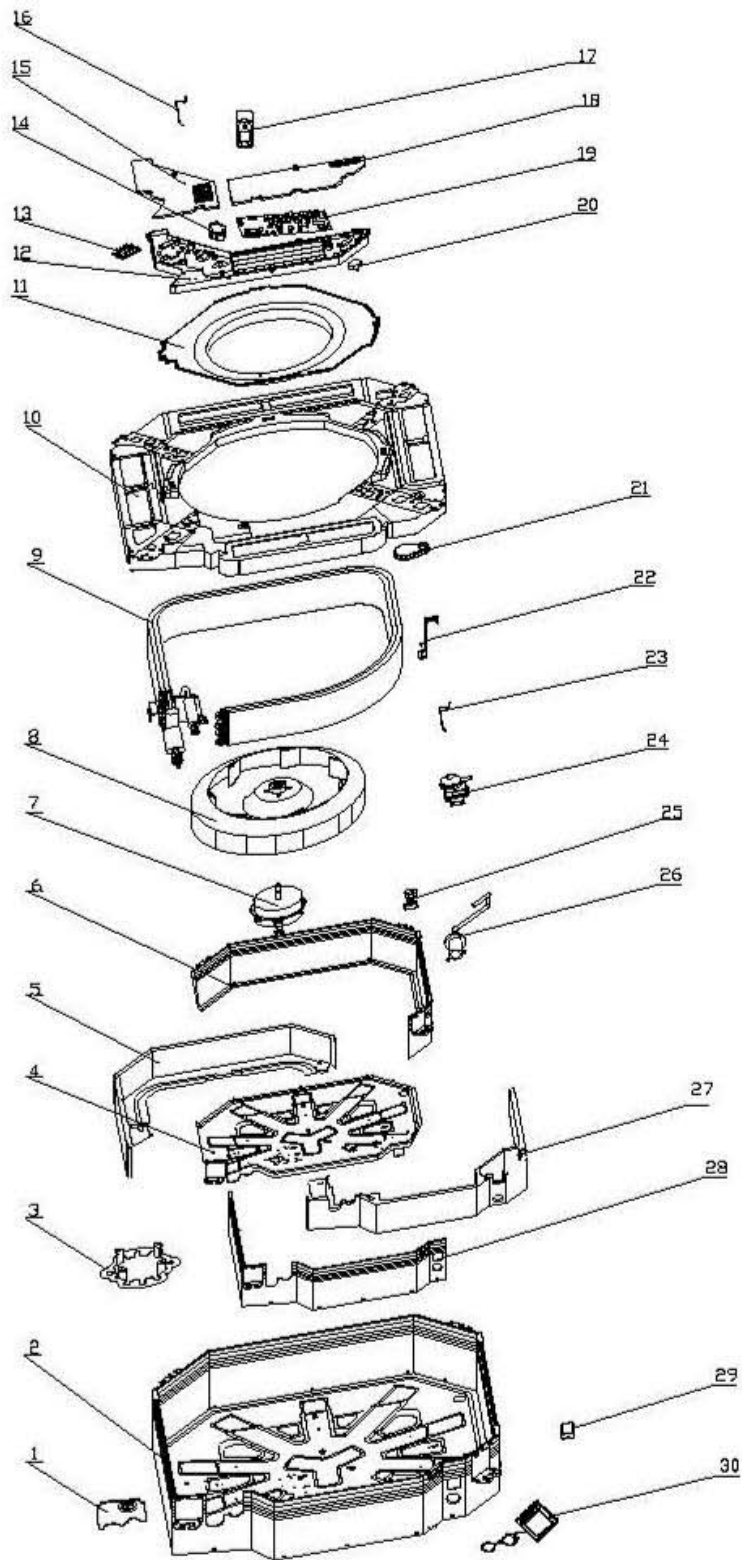

**13.10 Spare part list of Indoor Unit: CAD024**

NO.	Part Code	Part Description	qty
1	01382715	Tube Exit Plate Assy	1
2	01432703	Shell Assy	1
3	01702701	Motor Mounting Rack	1
4	01222701	Base Plate Assy	1
5	01302716	Right Side Plate	1
6	01302714	Rear Side Plate	1
7	15709404	Fan Motor	1
8	10312705	Centrifugal Fan	1
9	01029451	Evaporator Assy	1
10	20182701	Water Tray Assy	1
11	10372701	Flow Guide Loop	1
12	01399604	Electric Box Assy	1
13	42010258	Terminal Board	1
14	43110233	Transformer 48X26G	1
15	20122054	Electric Box Cover Sub-Assy1	1
16	390001921G	Tube Sensor	1
17	30510460	Remote controller YX1F1	1
18	20122055	Electric Box Cover Sub-Assy2	1
19	30227111	Main PCB Z71351E	1
20	33010010	Capacitor CBB61 3.5kuF/450V	1
21	05232702	Drain Hose Assy	1
22	01072703	Evaporator of Fixed Mount	2
23	390001911	Ambient Temperature Sensor	1
24	43130324	Water Pump	1
25	45010201	Water Level Switch	1
26	05230026	Drain Pipe for Water Pump	1
27	01302715	Left Side Plate Assy	1
28	01302718	Front Side Plate	1
29	01252713	Pump Backup Cover Plate Assy	1
30	30294219	Display Board	1
	05010051	Corrugated Pipe $\phi$ 16	2
	49010104	Magnetic Ring	1
	52012722	Bottom Foam Assy	1
	76712711	Motor Gasket	4
	10312701	Fan Fixer	1
	01332702	Water Pump Mounting Rack	1
	01074042	Connection Sheet Assy	1
	01332701	Major Mounting Plate	4

13.11 Exploded view of Indoor unit:CAD030

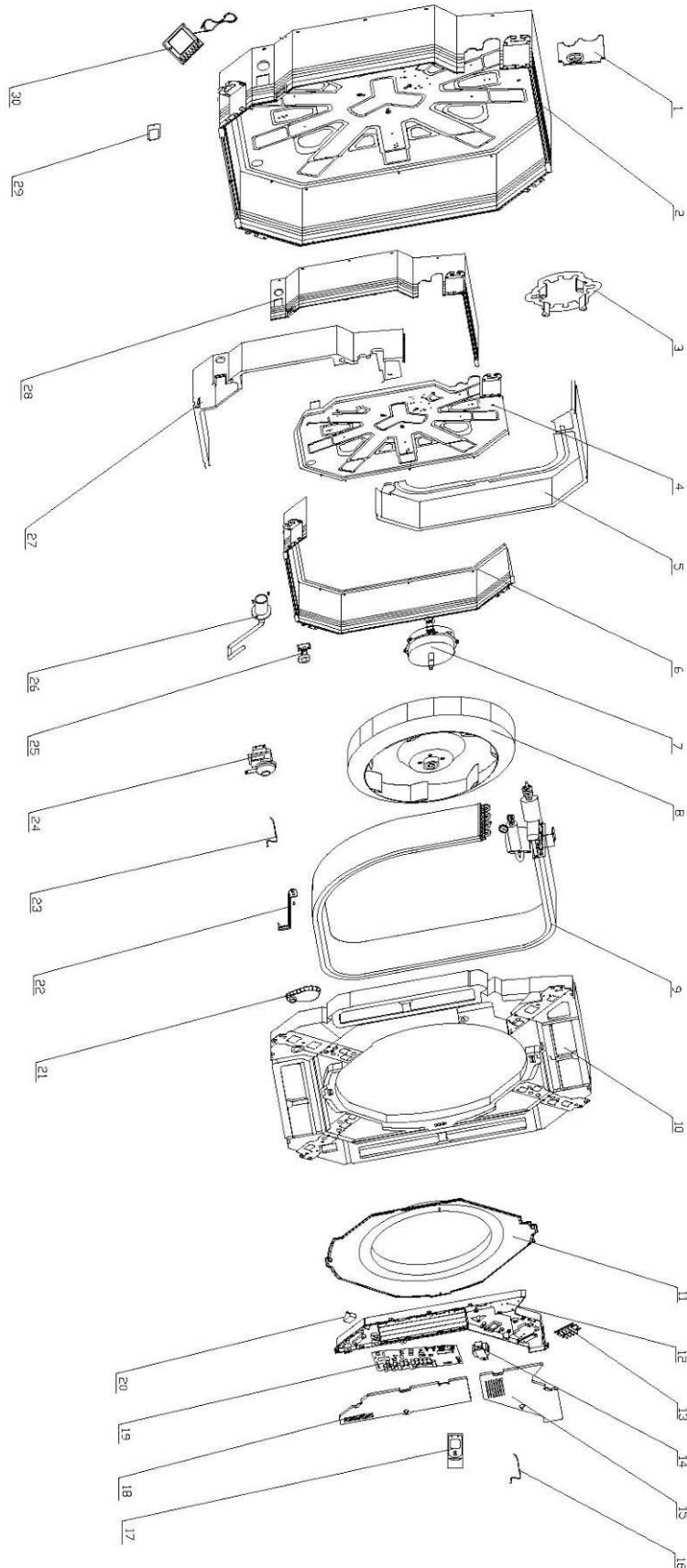

## 13.12 Spare part list of Indoor Unit:CAD030

NO.	Part Code	Part Description	qty
1	05010051	Corrugated Pipe φ16	2
1	01332701	Major Mounting Plate	4
1	42020063	Sensor Insert	1
1	01072732	Evaporator Linkage	1
1	76712711	Motor Gasket	4
1	05232702	Drain Hose Assy	1
1	10312701	Fan Fixer	1
1	01382715	Tube Exit Plate Assy	1
2	03412704	Shell Assy	1
3	01702701	Motor Mounting Rack	1
4	01222701	Base Plate Assy	1
5	01302712	Right Side Plate Assy	1
6	01302709	Rear Side Plate	1
7	15012706	Fan Motor	1
8	10310101	Centrifugal Fan	1
9	01029423	Evaporator Assy	1
10	20182701	Water Tray Assy	1
11	10372722	Flow Guide Loop	1
12	01399610	Electric Box Assy	1
13	42010258	Terminal Board	1
14	43110233	Transformer 48X26G	1
15	20122054	Electric Box Cover Sub-Assy1	1
16	390001921G	Tube Sensor	1
17	30510460	Remote controller YX1F1	1
18	20122055	Electric Box Cover Sub-Assy2	1
19	30227111	Main PCB Z71351E	1
20	33010012	Capacitor	1
21	05232044	Drain Hose	1
22	01072707	Evaporator of Fixed Mount	2
23	390001911	Ambient Temperature Sensor	1
24	43130324	Water Pump	1
25	45010201	Water Level Switch	1
26	05230026	Drain Pipe for Water Pump	1
27	01302711	Left Side Plate Assy	1
28	01302713	Front Side Plate	1
29	01252713	Pump Backup Cover Plate Assy	1
30	30294219	Display Board	1
	01332751	Water Pump Assy	1



13.13 Exploded view of Indoor unit:CAD036/042

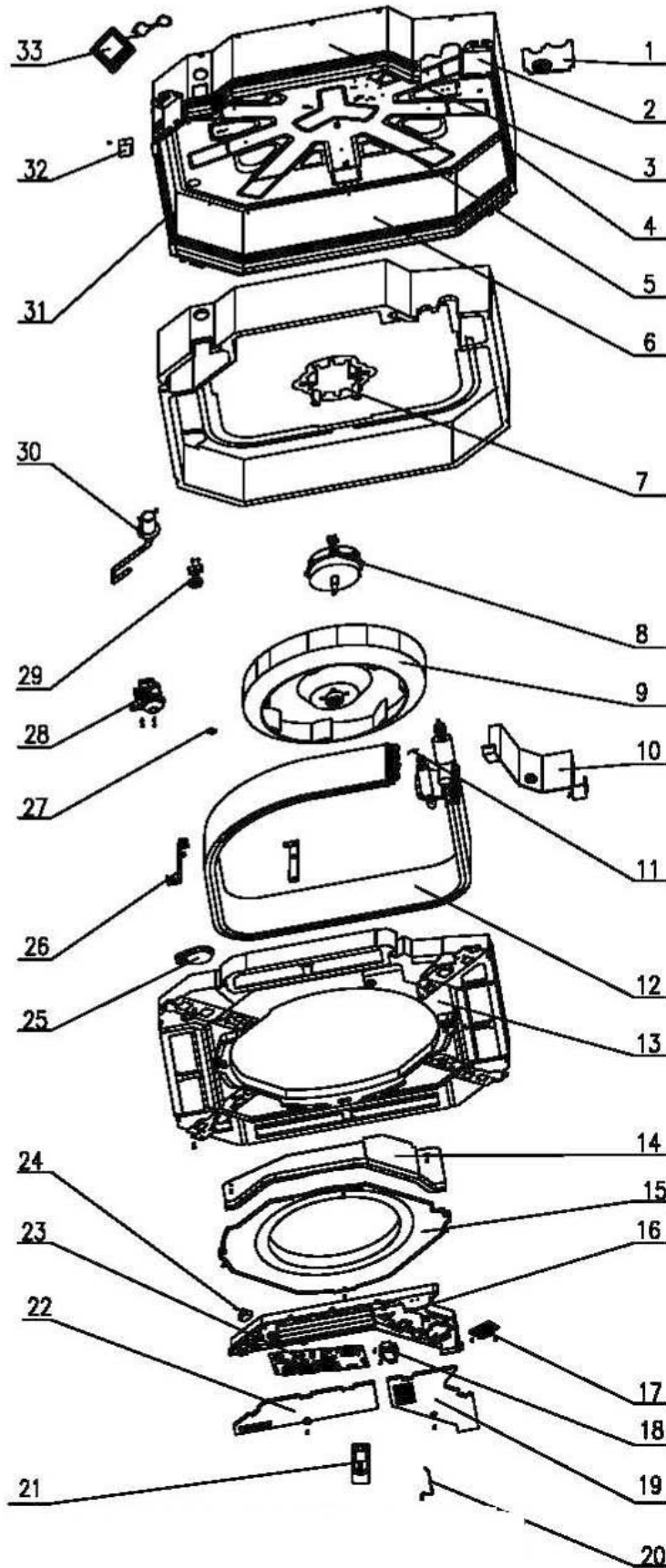

## 13.14 Spare part list of Indoor Unit:CAD036

NO.	Part Code	Part Description	qty
1	01382715	Tube Exit Plate Assy	1
3	01302713	Front Side Plate	1
4	01302711	Left Side Plate Assy	1
5	01222701	Base Plate Assy	1
6	01302709	Rear Side Plate	1
7	01702701	Motor Mounting Rack	1
8	15012706	Fan Motor	1
9	10310101	Centrifugal Fan	1
11	390001921	Tube Sensor (20K black)	1
12	01029423	Evaporator Assy	1
13	20182701	Water Tray Assy	1
15	10372722	Flow Guide Loop	1
16	01399610	Electric Box Assy	1
17	42010258	Terminal Board	1
18	43110233	Transformer 48X26G	1
19	20102702	Electric Box Cover	1
20	390001911	Ambient Temperature Sensor	1
21	30510460	Remote controller YX1F1	1
22	20102703	Electric Box Cover	1
23	30227111	Main PCB Z71351E	1
24	33010012	Capacitor	1
25	05232702	Drain Hose Assy	1
26	01072707	Evaporator of Fixed Mount	2
27	10312701	Fan Fixer	1
28	43130324	Water Pump	1
29	45010201	Water Level Switch	1
30	05230026	Drain Pipe for Water Pump	1
31	1302712	Right Side Plate Assy	1
32	01252713	Pump Backup Cover Plate Assy	1
33	30294219	Display Board	1
	020102701	Electric Box	1
	20122054	Electric Box Cover Sub-Assy1	1
	20122055	Electric Box Cover Sub-Assy2	1
	07210028	Filter Sub-assy	1
	49010252	Radiator	1
	01332751	Water Pump Assy	1
	05010051	Corrugated Pipe $\phi$ 16	2
	045020051	Dial Switch of Three-way	1

### 13.15 Spare part list of Indoor Unit:CAD042

NO.	Part Code	Part Description	qty
1	01382715	Tube Exit Plate Assy	1
3	01302713	Front Side Plate	1
4	01302711	Left Side Plate Assy	1
5	01222701	Base Plate Assy	1
6	01302709	Rear Side Plate	1
7	01702701	Motor Mounting Rack	1
8	15012706	Fan Motor	1
9	10310101	Centrifugal Fan	1
11	390001921	Tube Sensor (20K black)	1
12	01029422	Evaporator Assy	1
13	20182701	Water Tray Assy	1
15	10372722	Flow Guide Loop	1
16	1399509	Electric Box Assy	1
17	42010258	Terminal Board	1
18	43110233	Transformer 48X26G	1
19	20102702	Electric Box Cover	1
20	390001911	Ambient Temperature Sensor	1
21	30510460	Remote controller YX1F1	1
22	20102703	Electric Box Cover	1
23	30227111	Main PCB Z71351E	1
24	33010012	Capacitor	1
25	05232702	Drain Hose Assy	1
26	01072707	Evaporator of Fixed Mount	2
27	10312701	Fan Fixer	1
28	43130324	Water Pump	1
29	45010201	Water Level Switch	1
30	05230026	Drain Pipe for Water Pump	1
31	1302712	Right Side Plate Assy	1
32	01252713	Pump Backup Cover Plate Assy	1
33	30294219	Display Board	1
	020102701	Electric Box	1
	20122054	Electric Box Cover Sub-Assy1	1
	20122055	Electric Box Cover Sub-Assy2	1
	07210028	Filter Sub-assy	1
	49010252	Radiator	1
	01332751	Water Pump Assy	1
	05010051	Corrugated Pipe φ16	2
	045020051	Dial Switch of Three-way	1

13.16 Exploded view of Indoor unit: FAD024

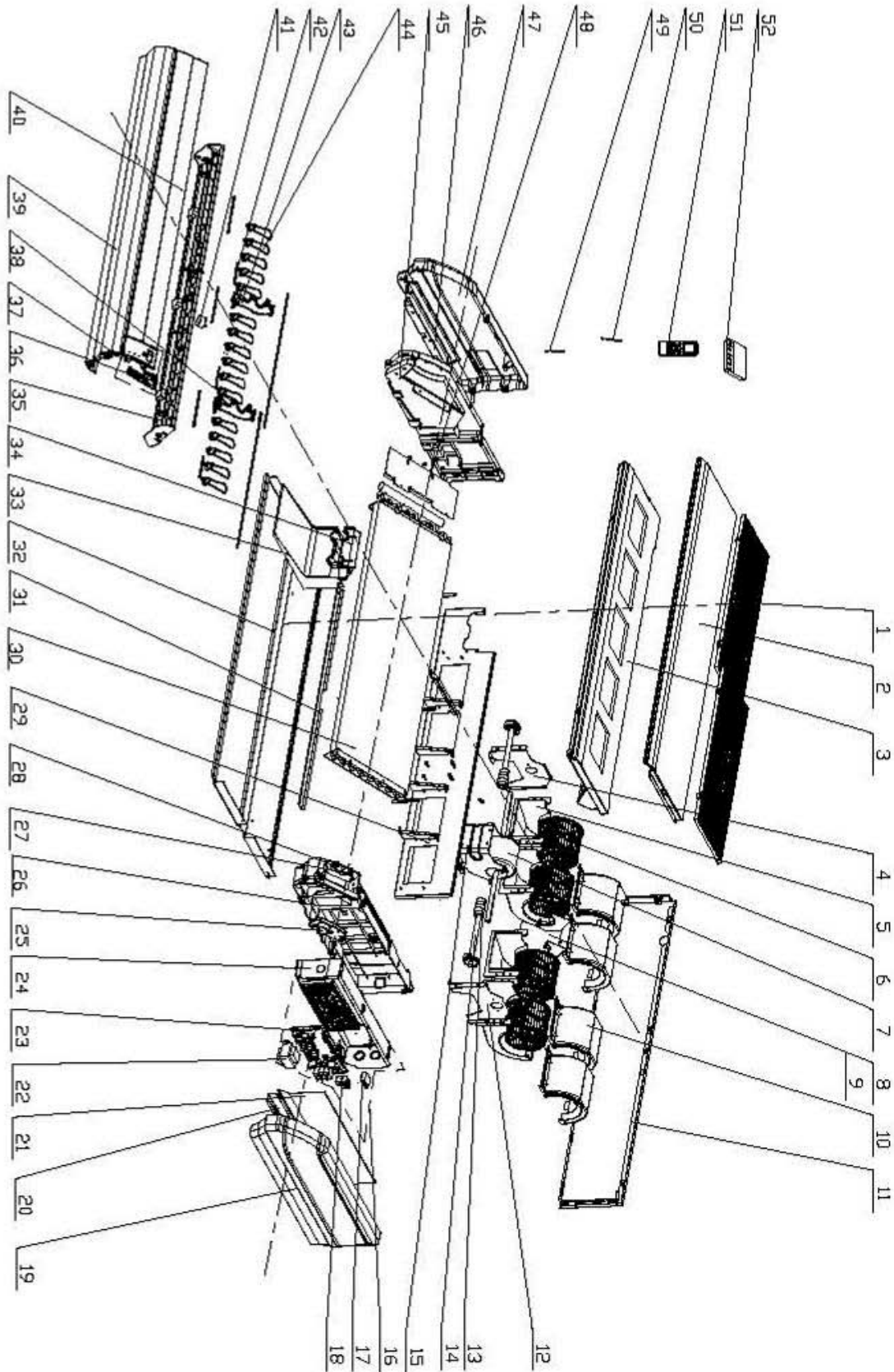

### 13.17 Spare part list of Indoor Unit:FAD024

NO.	Part Code	Part Description	qty
1	01579403	Front Grill sub-assy	2
2	01269409	Top Cover Board Sub-assy	1
3	01289404	Water Tray Assy	1
4	01809417	Supporter	1
5	26905206	Rear volute casing	4
6	10425200	Centrifugal fan	4
7	15709409	Fan Motor	1
8	70815201	Bar Clasp sub-assy	1
9	70818405	Bar Clasp	1
10	26905205	Front volute casing	4
11	01349416	Rear Connection board	1
12	01809418	Supporter	1
13	73018731	Joint Slack	2
14	02289405	Rotary Axis Sub-Assy	2
15	01805288	Supporter	1
16	01399501	Electric Box Assy	1
17	33010025	Capacitor	1
18	42010178	Terminal Board	1
19	26909443	Left Cover Plate	1
20	01809401	Left Pensile Bracket	1
21	01429420	Electric Box Cover	1
22	4311023701	Transformer	1
23	30224223	Main Board	1
24	01429419	Electric Box	1
25	1521240206	Step Motor	1
26	01319428	Left Side Plate Sub-Assy	1
27	26909412	Rotating Shaft	1
28	26909413	Rotating Shaft	1
29	01249416	Mid-clapboard sub-assy	1
30	01029462	Evaporator Assy	1
31	02229418	Air Deflector Sub-Assy.	1
32	01319430	Rear side plate assy	1
33	26909442	Fixed Plate	1
35	26909448	Base Frame	1
36	30294224	Display Board	1
37	02229416	Display Board Sub-Assy	1
38	26909430	Rotating Shaft	4
39	01349414P	Front Connection Board	1
40	10619403	Guide Louver	2
41	1521240201	Step Motor MP35CB	1
42	26112127	Swing Louver	3
43	26909449	Supporter	2
44	10619404	Air Louver	16
45	01319429	Right Side Plate Sub-Assy	1
46	01809402	Right Pensile Bracket	1
47	26909444	Right Cover Plate	1
48	02229406	Connection Board	1
49	3900020723	Sensor	1
50	39000191	Ambient Temperature Sensor	1
51	30510460	Remote controller YX1F1	1
52	30294219	Display Board	1
	05235434	Drainage Pipe Sub-assy	1
	10542704	Axial Bush	2

13.18 Exploded view of Indoor unit: FAD030/036

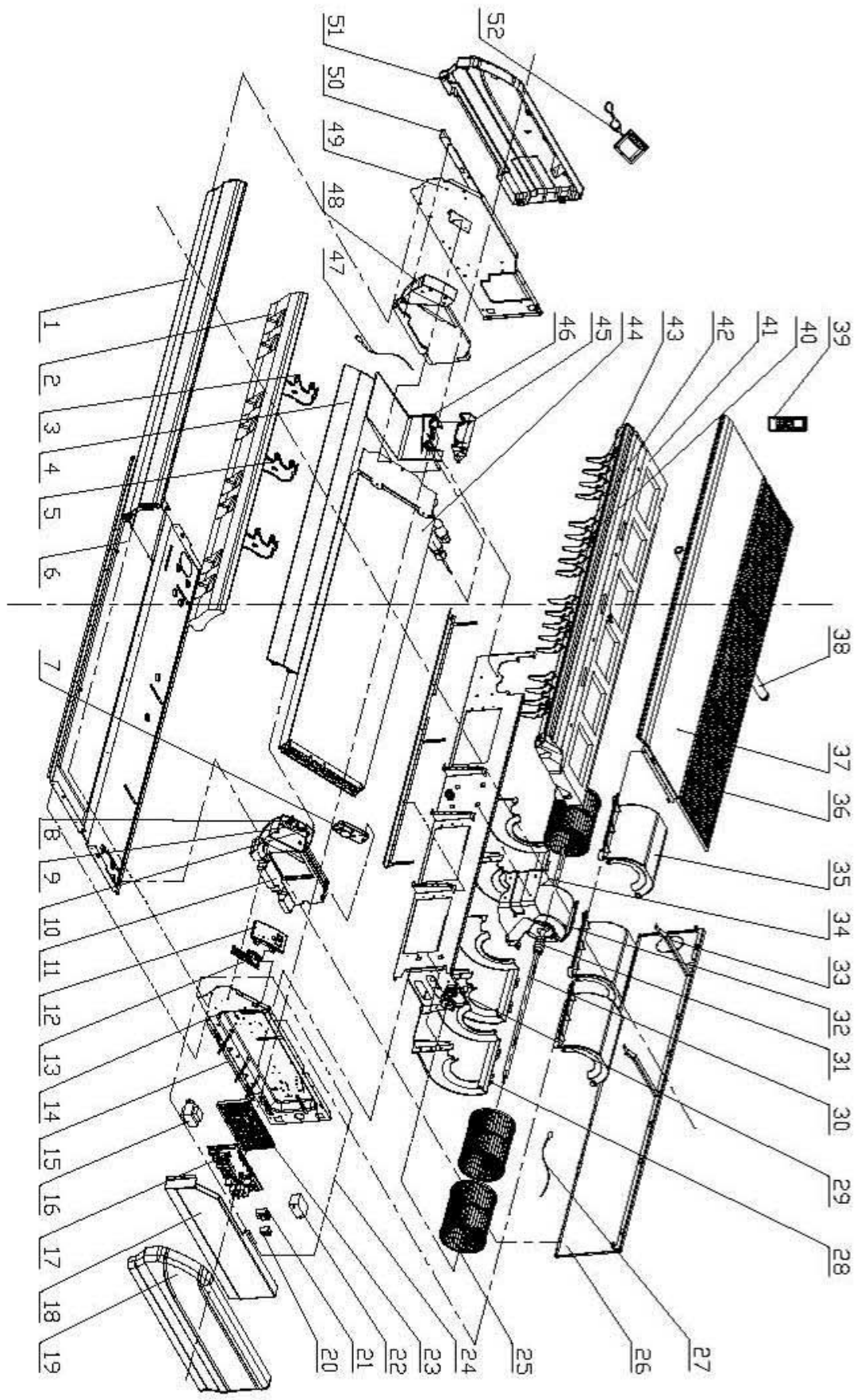

### 13.19 Spare part list of Indoor Unit:FAD030

NO.	Part Code	Part Description	qty
1	01349408P	Front panel	1
2	12509424	Front foam assy	1
3	26909430	Rotating Shaft	6
4	26909432	Guide Louver	2
5	26909409	Bracket #3(Guide Louver)	3
6	0131941901	Rear side plate assy	1
7	1521240206	Step Motor	1
8	26909413	Rotating Shaft	1
9	26909411	Connecting Rod	1
10	26909412	Rotating Shaft	1
11	12509408	Left foam assy	1
12	02229416	Display Board Sub-Assy	1
13	30294224	Display Board	1
14	01319406	Left Side Plate Sub-Assy	1
15	01809401	Left Pensile Bracket	1
16	4311023701	Transformer	1
17	30224223	Main Board	1
18	01429410P	Electric Box Cover	1
19	26909416	Left Cover	1
20	42010178	Terminal Board	1
21	420101852	Terminal Board	1
22	33010013	Capacitor	1
23	26909407	Fixed Plate for main board	1
24	01399476	Controller assy.	1
25	1041410101	Centrifugal fan	3
26	01349410	Rear connect plate	1
27	39000191	Ambient Temperature Sensor	1
28	26909419	Front volute casing	3
29	76512404	O-Gasket of Bearing	1
30	73018052	Rotary Axis Sub-Assy	1
31	73018731	Joint Slack	1
32	15709408	Fan Motor	1
33	02229408	Fixing plate	2
34	01329413	Bracket for motor	1
35	26909419	Rear volute casing	3
36	01579402	Front Grill sub-assy	3
37	01269404P	Top cover	1
38	05235434	Drainage Pipe Sub-assy	1
39	30510460	Remote controller YX1F1	1
40	10582009	Swing Lever	2
41	01289405	Water tray assy	1
42	26909418	Air Louver	18
43	10582009	Swing Link Lever	2
44	01029457	Evaporator Assy	1
45	26909441	Water Groove	1
46	26909442	Fixed Plate	1
47	3900020720	Sensor(20K)	1
48	12509425	Right foam assy	1
49	01319408	Right Side Plate Sub-Assy	1
50	01809402	Right Pensile Bracket	1
51	26909422	Right Cover	1
52	30294219	Display Board	1
	01702405	Motor Press Plate	2
	01792408	Support Of Motor Bearing	1
	76515202	Cable-Cross Loop	1
	02229406	Connection Board	1
	10542704	Axial Bush	2
	42020063	Sensor Insert	1

## 13.20 Spare part list of Indoor Unit:FAD036

NO.	Part Code	Part Description	qty
1	01349408P	Front panel	1
2	12509424	Front foam assy	1
3	26909430	Rotating Shaft	6
4	26909432	Guide Louver	2
5	26909409	Bracket #3(Guide Louver)	3
6	0131941901	Rear side plate assy	1
7	1521240206	Step Motor	1
8	26909413	Rotating Shaft	1
9	26909411	Connecting Rod	1
10	26909412	Rotating Shaft	1
11	12509408	Left foam assy	1
12	02229416	Display Board Sub-Assy	1
13	30294224	Display Board	1
14	01319406	Left Side Plate Sub-Assy	1
15	01809401	Left Pensile Bracket	1
16	4311023701	Transformer	1
17	30224223	Main Board	1
18	01429410P	Electric Box Cover	1
19	26909416	Left Cover	1
20	42010178	Terminal Board	1
21	420101852	Terminal Board	1
22	33010014	Capacitor	1
23	26909407	Fixed Plate for main board	1
24	01399459	Controller assy. GTH36K1BI	1
25	1041410101	Centrifugal fan	3
26	01349410	Rear connect plate	1
27	39000191	Ambient Temperature Sensor	1
28	26905208	Front volute casing	3
29	76512404	O-Gasket of Bearing	1
30	73018052	Rotary Axis Sub-Assy	1
31	73018731	Joint Slack	1
32	15709407	Fan Motor	1
33	02229408	Fixing plate	2
34	01329407	Bracket for motor	1
35	26909419	Rear volute casing	3
36	01579402	Front Grill sub-assy	3
37	01269404P	Top cover	1
38	05235434	Drainage Pipe Sub-assy	1
39	30510460	Remote controller YX1F1	1
40	10582008	Swing Lever	2
41	01289405	Water tray assy	1
42	26909418	Air Louver	18
43	10582009	Swing Link Lever	2
44	01029455	Evaporator Assy	1
45	26909441	Water Groove	1
46	26909442	Fixed Plate	1
47	3900020720	Sensor(20K)	1
48	12509425	Right foam assy	1
49	01319408	Right Side Plate Sub-Assy	1
50	01809402	Right Pensile Bracket	1
51	26909422	Right Cover	1
52	30294219	Display Board	1
	01702405	Motor Press Plate	2
	01792408	Support Of Motor Bearing	1
	76515202	Cable-Cross Loop	1
	02229406	Connection Board	1
	10542704	Axial Bush	2
	42020063	Sensor Insert	1



13.21 Exploded view of Indoor unit: FAD048

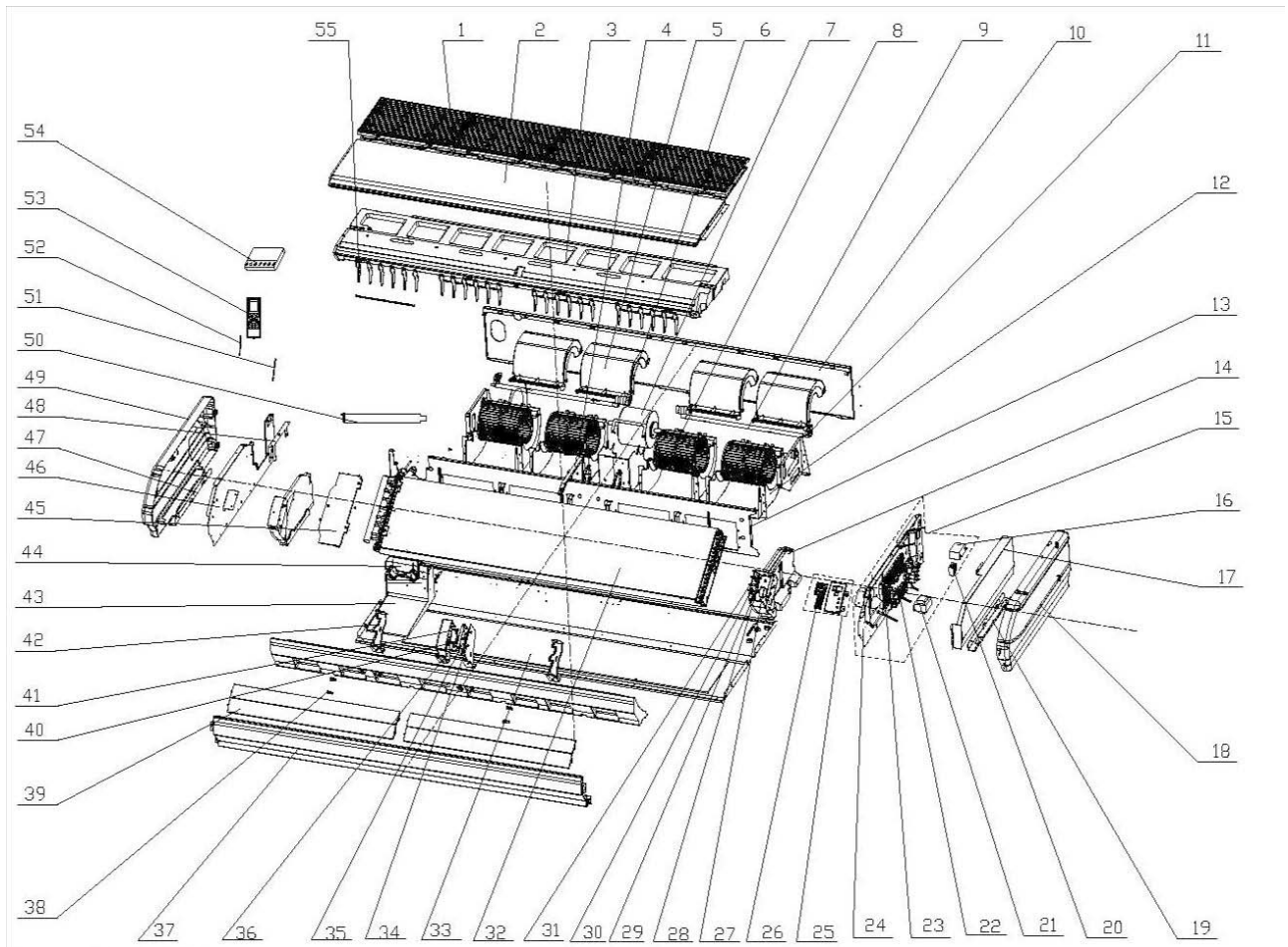

## 13.22 Spare part list of Indoor Unit:FAD048

NO.	Part Code	Part Description	qty
1	01579401	Front Grill sub-assy	4
2	01269403	Top Cover Board Sub-assy	1
3	01289401	Water tray assy	1
4	02229408	Spacing Board	2
5	26909419	Rear volute casing	4
6	73018731	Joint Slack	2
7	15709405	Fan Motor	1
8	1041410101	Centrifugal fan	4
9	73018052	Rotary Axis Sub-Assy	2
10	01349411	Rear Connection Board	1
11	01792408	Support Of Motor Bearing	2
12	26905208	Front volute casing	4
13	0124940202	Mid Clapboard	1
14	12509408	Left foam assy	1
15	01399512	Controller assy.	1
16	33010014	Capacitor	1
17	01429410P	Electric Box Cover	1
18	26909422	Left Cover Plate	1
19	01809401	Installation Supporting Frame	1
20	42010178	Terminal Board	1
21	4311023701	Transformer	1
22	30224223	Main Board	1
23	26909407	PCB Base	1
24	01319406	Left Side Plate Sub-Assy	1
25	02229416	Display Board Sub-Assy	1
26	30294224	Display Board	1
27	1521240206	Step Motor	1
28	10542704	Axial Bush	2
29	26909411	Connecting Rod	1
30	26909413	Rotating Shaft	1
31	26909412	Rotating Shaft	1
32	01029466	Evaporator Assy	1
33	01319422	Rear side plate assy	1
34	10542704	Axial Bush	2
35	1521240201	Step Motor	1
36	26909411	Connecting Rod	1
37	01349404P	Front connect plate	1
38	26909430	Rotating Shaft	4
39	26909408	Guide Louver	4
40	26909413	Rotating Shaft	1
41	26909412	Rotating Shaft	1
42	26909409	Supporter	2
43	26909441	Water Groove	1
44	26909442	Fixed Plate	1
45	01349412	Connected Board(Evap.)	1
46	01319408	Right Side Plate Sub-Assy	1
47	01809402	Installation Supporting Frame	1
48	02229406	Connection Board	1
49	26909422	Right Cover Plate	1
50	05235434	Drainage Pipe Sub-assy	1
51	39000191	Room Sensor	1
52	3900020720G	Tube Sensor	1
53	30510460	Remote controller YX1F1	1
54	30294219	Display Board	1
55	26909418	Air Louver	24

13.23 Exploded view of outdoor unit: YUD024 030

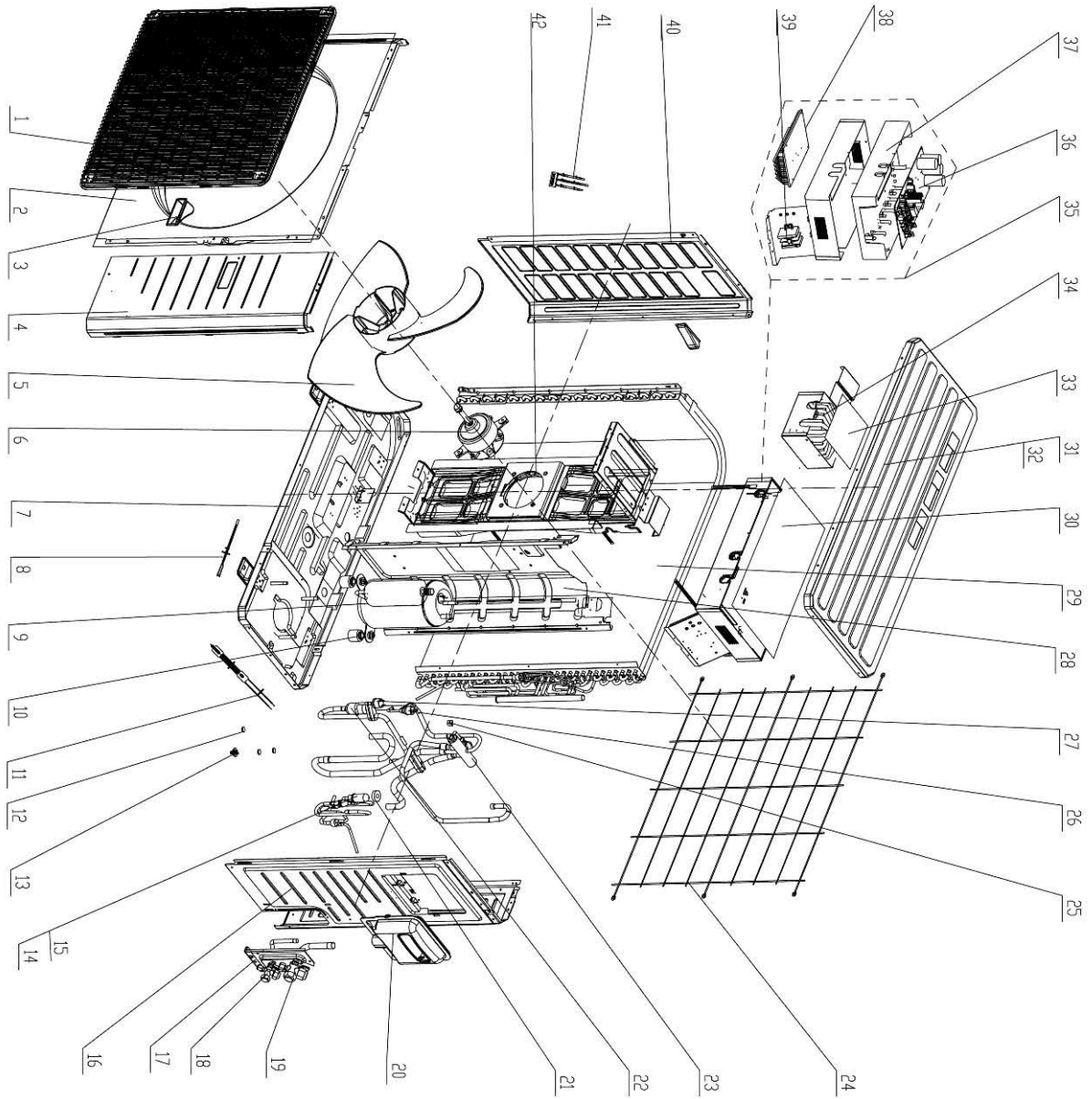

**13.24 Spare part list of Outdoor Unit YUD024/030**

NO.	Part Code	Part Description	qty
1	22415003	Front Grill	1
2	01435004P	Cabinet	1
3	26235401	Left Handle	2
4	01305086P	Front Side Plate	1
5	10335005	Axial Flow Fan	1
6	1570280202	Fan Motor	1
7	01195322P	Chassis Sub-assy	1
8	765100047	Electrical Heater	1
9	00105036	Compressor and fittings	1
10	76710207	Compressor Gasket	3
11	76518732	electrical heater	1
12	06813401	Drainage Plug	3
13	06123401	Drainage Connector	1
14	07210022	StrainerA	2
15	07334193	Electronic Expansion Valve	1
16	01305044P	Right Side Plate	1
17	01715012P	Valve Support Sub-Assy	1
18	07100005	Valve	1
19	07133157	Cut-off Valve	1
20	26235001	Big Handle	1
21	4300010818	Electric expand valve fitting	1
22	07245007	Silencer Mounting	1
23	4300008201	4-way Valve	1
24	01475008	Rear Grill	1
25	4300040029	Magnet Coil	1
26	46020006	Pressure Protect Switch	1
27	46020003	Pressure Protect Switch	1
28	01245237	Clapboard	1
29	01125394	Condenser Assy	1
30	01425281	Electric Box Cover	1
31	01255006P	Top Cover	1
32	01255007	Top Cover Sub-Assy	1
33	01425279	Electric Box Cover	1
34	43128003	PFC Inductance	1
35	02405227	Electric Box Assy	1
36	30224074	Main Board	1
37	26905211	Electric Box	1
38	49018112	Radiator	1
39	420111451	Terminal Board	1
40	01305043P	Left Side Plate	1
41	3900028016G	Temperature Sensor	1
42	01805741	Motor Support Sub-Assy	1

13.25 Exploded view of outdoor unit: YUD036

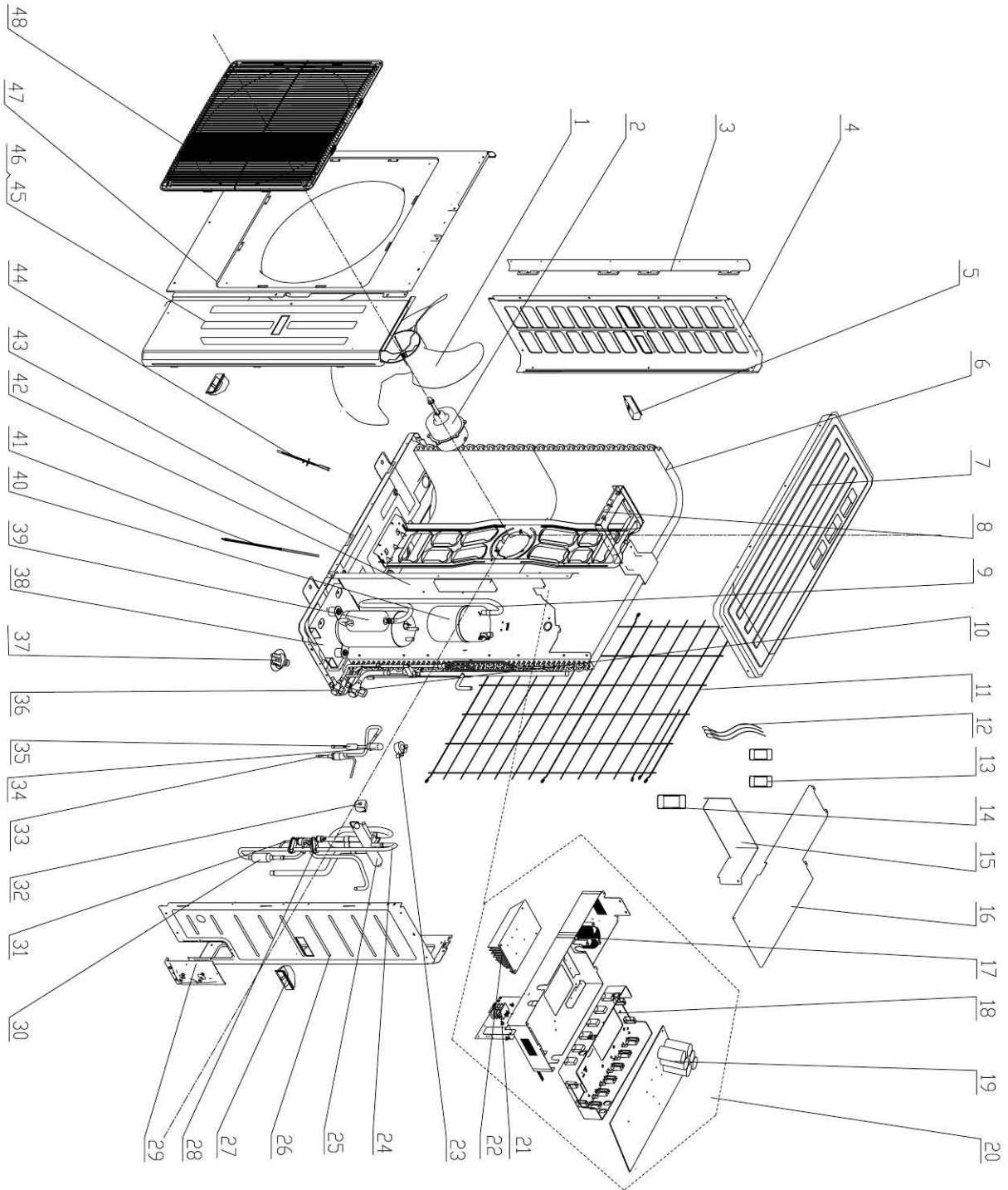

## 13.26 Spare part list of Outdoor Unit YUD036

NO.	Part Code	Part Description	qty
1	10335010	Axial Flow Fan	1
2	1570280201	Fan Motor	1
3	01795020	Condenser support plate	1
4	01305064P	Left Side Plate	1
5	26235401	Left Handle	1
6	01125392	Condenser Assy	1
7	0125500901P	Top Cover	1
8	01705111	Motor Support Sub-Assy	1
9	04655520	Inhalation Tube 1	1
10	07133157	Cut-off Valve	1
11	01475012	Rear Grill	1
12	3900028017G	Temperature Sensor	1
13	49010109	Magnetic Ring	1
14	49010104	Magnetic Ring	2
15	01355204	Air Guard	1
16	01265398	Electric Box Cover	1
17	4312001101	PFC Inductance	1
18	26905211	Electric Box	1
19	30224075	Main Board	1
20	02405224	Electric Box Assy	1
21	42011242	Terminal Board	1
22	49018112	Radiator	1
23	4300010822	Electric expand valve fitting	1
24	04145732	4-way Valve Assy	1
25	43000338	4-way Valve	1
26	01305441P	Right Side Plate Sub-Assy	1
27	26235253	Handle	2
28	46020006	Pressure Protect Switch	1
29	01715257P	Valve Support Sub-Assy	1
30	07215201	Filter	1
31	46020003	Pressure Protect Switch	1
32	4300040029	Magnet Coil	1
33	07335263	Electric Expansion Valve Sub-Assy	1
34	07334194	Electronic Expansion Valve	1
35	07210045	Strainer	1
36	071302391	Cut off Valve	1
37	26113009	Drainage Joint	1
38	01845235P	Retaining Plate Sub-Assy	1
39	00205275	Compressor and Fittings	1
40	07255201	Gas-liquid Separator Sub-Assy	1
41	76518732	electrical heater	1
42	01245261	Clapboard Sub-Assy	1
43	01195315P	Chassis Sub-assy	1
44	765100048	Electrical Heater	1
45	01305508	Front Side Plate Sub-Assy	1
46	01305065P	Front Side Plate	1
47	01435007P	Cabinet	1
48	22415005	Front Grill	1

13.27 Exploded view of outdoor unit: YUD036T/YUD042

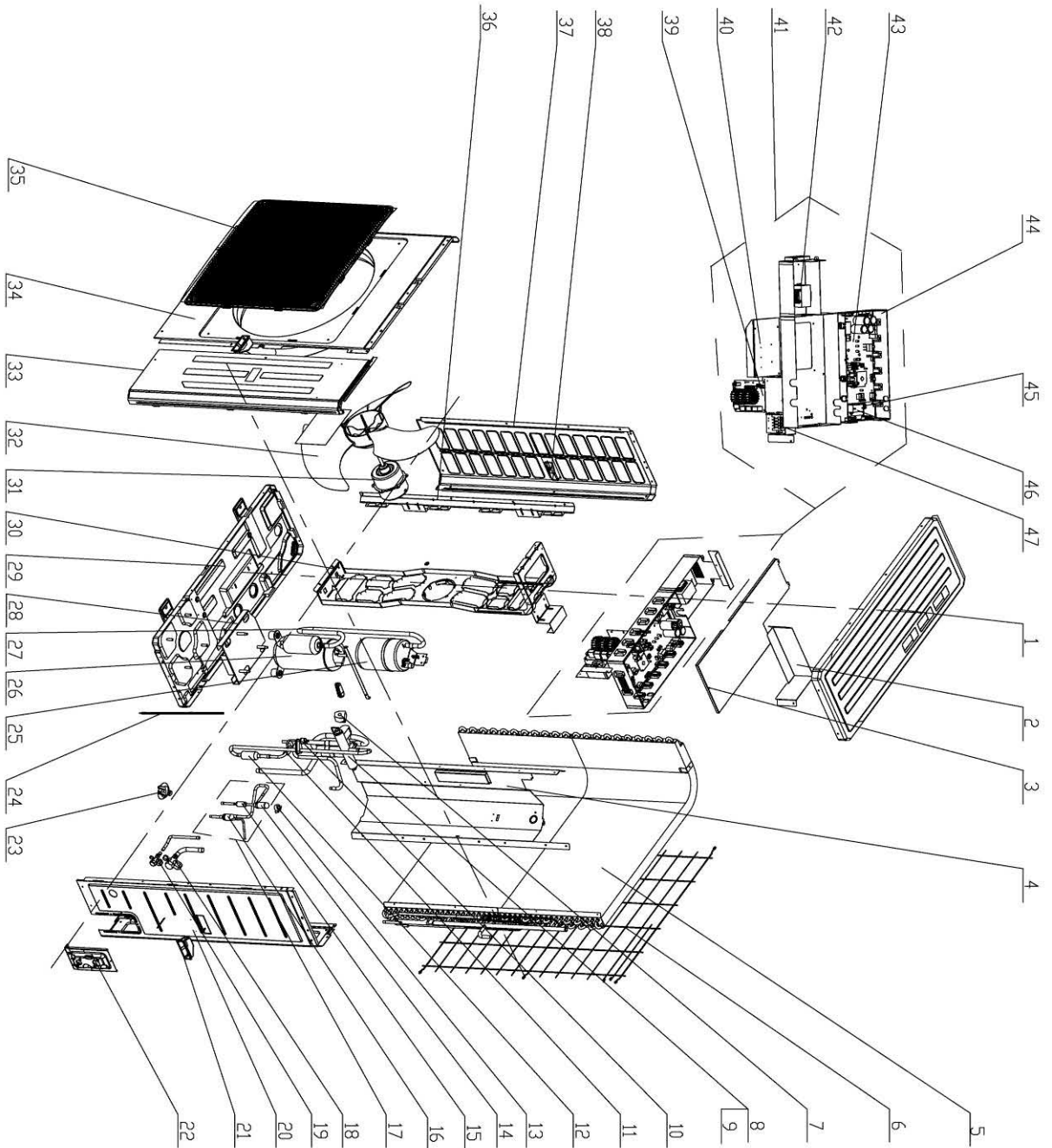

**13.28 Spare part list of Outdoor Unit YUD036T/YUD042:**

NO.	Part Code	Part Description	qty
1	01255009P	Top Cover	1
2	01355204	Air Guard	1
3	01125373	Condenser Assy	1
4	01475012	Rear Grill	1
5	04145342	4-way Valve Assy	1
6	43000338	4-way Valve	1
7	46020006	Pressure Protect Switch	1
8	3900028002G	Temperature Sensor	1
9	07334194	Electronic Expansion Valve	1
10	07335263	Electric Expansion Valve Sub-Assy	1
11	07133157	Cut-off Valve	1
12	071302391	Cut off Valve	1
13	01305441P	Right Side Plate Sub-Assy	1
14	26235253	Handle	2
15	01715257P	Valve Support Sub-Assy	1
16	02145008	Fix Clamp	1
17	76518732	electrical heater	1
18	07255201	Gas-liquid Separator Sub-Assy	1
19	00205236	Compressor and fittings	1
20	04655520	Inhalation Tube 1	1
21	01845235P	Retaining Plate Sub-Assy	1
22	01195244P	Chassis Sub-assy	1
23	01805396	Motor Support Assy	1
24	01705111	Motor Support Sub-Assy	1
25	150154516	Fan Motor	1
26	10335010	Axial Flow Fan	1
27	20113003	Insulating Plate of Electric box Cover	1
28	01305508	Front Side Plate Sub-Assy	1
29	01435007P	Cabinet	1
30	22415005	Front Grill	1
31	01895309	Condenser support plate	1
32	01305064P	Left Side Plate	1
33	26235401	Left Handle	1
34	01395956	Electric Box Assy	1
35	49018113	Radiator	1
36	43130178	Reactor	1
37	30228806	Main Board	1
38	26905211	Electric Box	1
39	33030013	XY Capacitor	1
40	30224311	Main Board	1
41	43110030	High Frequency Transformer	1
42	30228118	Filter Board	1
43	44020378	Relay	1
44	42011221	Terminal Board	1
45	33010009	Capacitor CBB61	1
46	42011103	Terminal Board	1
	4300010812	Magnet Coil for Electronic Expansion Valve	1
	4300040029	Magnet Coil	1
	26113009	Drainage Joint	1
	04325628	Condenser inlet pipe sub-assy	1



13.29 Exploded view of outdoor unit: YUD048/060

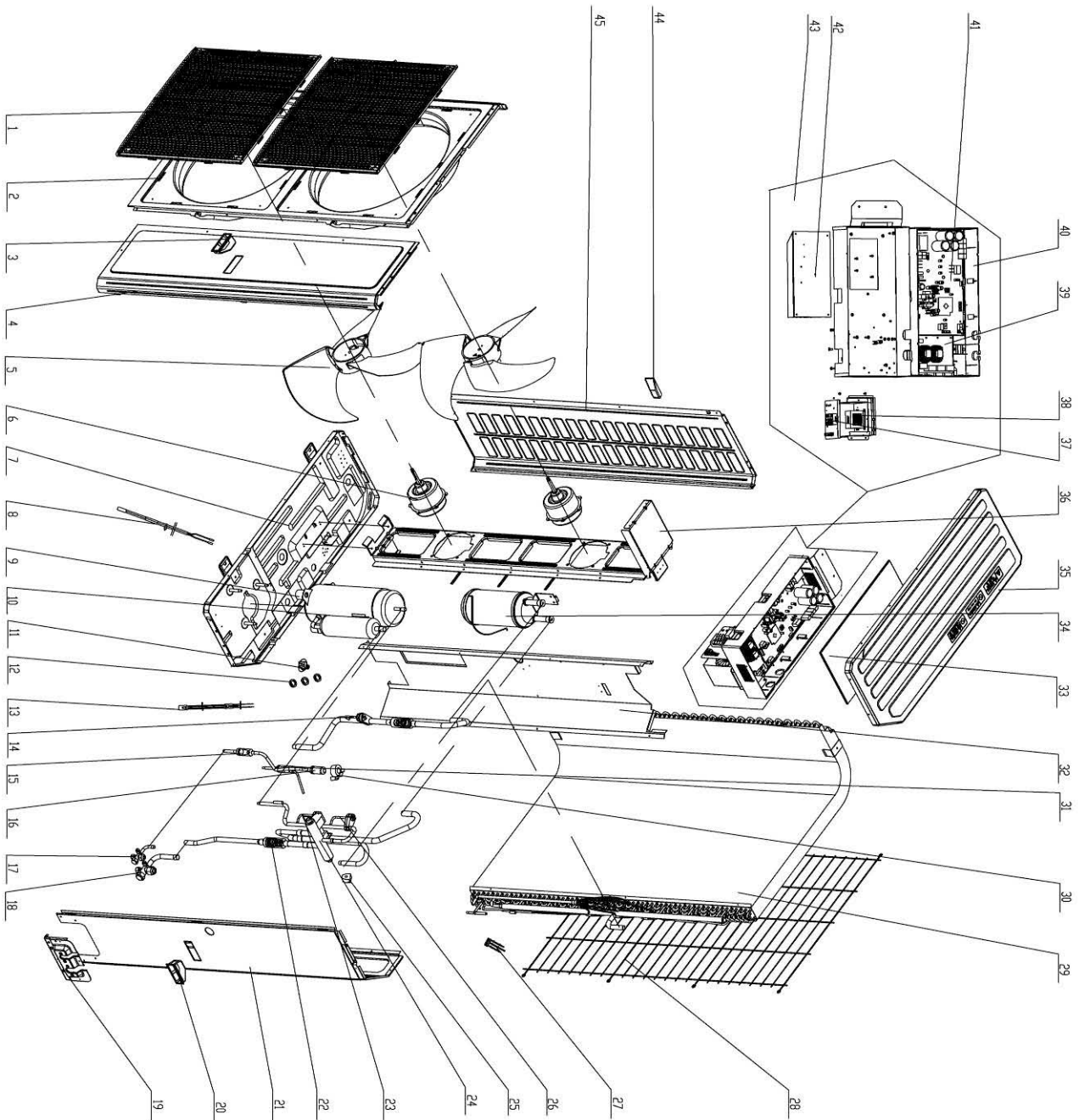

## 13.30 Spare part list of Outdoor Unit: YUD048/YUD060

NO.	Part Code	Part Description	qty
1	22415002	Front Grill	2
2	01515204P	Cabinet	1
3	26235253	Handle	1
4	01315364P	Front Side Plate	1
5	10335008	Axial Flow Fan	2
6	1570280203	Fan Motor	2
7	01195710P	Chassis Sub-assy	1
8	765100047	Electrical Heater	1
9	76815204	Compressor Gasket	3
10	00204126	Compressor and fittings	1
11	06123401	Drainage Connector	1
12	06813401	Drainage Plug	3
13	765152123	electrical heater	1
14	46020007	Pressure Protect Switch	1
15	07220016	Bidirection Strainer	1
16	07334194	Electronic Expansion Valve	1
17	07130209	Cut off Valve	1
18	07103030	Gas Valve Sub-Assy	1
19	01715001	Valve Support Sub-Assy	1
20	26235253	Handle	1
21	01314306P	Rear Side Plate Sub-Assy	1
22	07210037	Filter	1
23	46020003	Pressure Protect Switch	1
24	43000338	4-way Valve	1
25	4300040032	Magnet Coil	1
26	46020006	Pressure Protect Switch	1
27	3900028015G	Temperature Sensor	1
28	01575205	Rear Grill	1
29	01025396	Condenser Assy	1
30	4300010813	Electric expand valve fitting	1
31	07210037	Filter	1
32	01245269	Clapboard Assy	1
33	01424235	Electric Box Cover	
34	07225018	Gas-liquid Separator Sub-Assy	1
35	01265356P	Top Cover	1
36	01805722	Motor Support Assy	1
37	42011223	Terminal Board	1
38	43138004	Reactor	1
39	30228118	Filter Board	1
40	26904131	Electric Box	1
41	30228007	Main Board	1
42	49018028	Radiator	1
43	02405225	Controller box assy.	1
44	26235401	Left Handle	1
45	01315366P	Left Side Plate	1

# APPENDIX