

AIR CONDITIONER CASSETTE



English

Indoor unit cassette type

Content

1. REQUIRED TOOLS FOR INSTALLATION WORK	2
2. SAFETY PRECAUTIONS	2
3. INSTALLATION/SERVICE TOOLS (Only for R410A product)	4
4. ACCESSORIES	5
5. OPTIONAL ACCESSORIES	6
6. LOCATION OF THE INDOOR AND OUTDOOR UNITS	6
7. INSTALLATION OF THE INDOOR UNIT	9
8. CONDENSATE HOSE CONNECTION	13
9. ELECTRICAL CONNECTION BETWEEN INDOOR AND OUTDOOR UNIT	15
10. REFRIGERANT TUBING	17
11. PANEL INSTALLING	19
12. FINAL TASKS	21

The appliance shall not be installed in the laundry

Note:

This manual is for single split applications.

For multi split applications please use installation manual supplied within outdoor unit package.

This manual can be modified at any moment

1. REQUIRED TOOLS FOR INSTALLATION WORK

1. Screw driver	7. Knife	13. Torque wrench
2. Electric drill, hole core drill (Φ 60mm)	8. Gas leak detector	18 N . m (1.8kgf.m)
3. Hexagonal wrench	9. Measuring tape	35 N .m (3.5kgf.m)
4. Spanner	10. Thermometer	55 N .m (5.5kgf.m)
5. Pipe cutter	11. Megameter	14. Vacuum pump
6. Reamer	12. Multimeter	15. Gauge manifold (for R-410A)

2. SAFETY PRECAUTIONS

- Installation should be in accordance with local and national electrical and building fire safety regulations or codes.
- Read the following "SAFETY PRECAUTIONS" carefully before installation.
- Electrical work must be installed by a licensed electrician. Be sure to use the correct rating of the power plug and main circuit for the model to be installed.
- The caution items stated here must be followed because these important contents are related to safety. The meaning of each indication used is as below. Incorrect installation due to ignoring of the instruction will cause harm or damage, and the seriousness is classified by the following indications.
- Carry out test running to confirm that no abnormality occurs after the installation. Then, explain to user the operation, care and maintenance as stated in instructions. Please remind the customer to keep the operating instructions for future reference.

WARNING

- 1) Engage qualified installers and follow instruction carefully. Otherwise it will cause electrical shock, water leakage, or esthetic problem.
- 2) Install at a strong and firm location which is able to withstand the set's weight. If the strength is not enough or installation is not properly done, the set will drop and cause injury.
- 3) For electrical work, follow the local national wiring standard, regulation and this installation instruction. An independent circuit and single outlet must be used. If electrical circuit capacity is not enough or defect found in electrical work, it will cause electrical shock or fire.
- 4) Use the specified cable and connect tightly for indoor/outdoor connection. Connect tightly and clamp the cable so that no external force will be acted on the terminal. If connection or fixing is not perfect, it will cause heat-up or fire at the connection.
- 5) Wire routing must be properly arranged so that control board cover is fixed properly. If control board cover is not fixed perfectly, it will cause heat-up at connection point of terminal, fire or electrical shock.
- 6) When carrying out piping connection, take care not to let air substances other than the specified refrigerant go into refrigeration cycle. Otherwise, it will cause lower capacity, abnormal high pressure in the refrigeration cycle, explosion and injury.
- 7) Do not damage or use unspecified power supply cord. Otherwise, it will cause fire or electrical shock.
- 8) Do not modify the length of the power supply cord or use of the extension cord, and do not share the single outlet with other electrical appliances. Otherwise, it will cause fire or electrical shock.
- 9) This equipment must be earthed. It may cause electrical shock if grounding is not perfect.

- 10) Do not install the unit: in such places above, there is a risk of unit catching fire.
 - a) at places where leakage of flammable gas may occur, or oil or vapor or other flammable substances are in the air
 - b) above cookers, specially in kitchens
 - c) close to heating devices where units are exposed to high temperatures.
- 11) Carry out drainage piping as mentioned in installation instructions. If drainage is not perfect, water may enter the room and damage the furniture.
- 12) For appliances with supplementary heaters, the minimum clearance from the appliance to combustible is 50cm other wise, it will cause fire.

ATTENTION

- 1) Selection of the installation location.
Select an installation location which is rigid and strong enough to support or hold the unit, also for easy maintenance and repair.
- 2) Power supply connection to the room air conditioner.
Connect the power supply cord of the room air conditioner to the mains using one of the following method.
Power supply point shall be the place where there is ease for access for the power disconnection in case of emergency.
In some countries, permanent connection of this room air conditioner to the power supply is prohibited.
- 3) Do not release refrigerant.
Do not release refrigerant during piping work for installation, reinstallation and during repairing a refrigeration parts. Take care of the liquid refrigerant. it may cause frostbite.
- 4) Installation work. It may need two people to carry out the installation work.
- 5) Do not install this appliance in a laundry room or other location where water may drip from the ceiling, etc.
- 6) The temperature of refrigerant circuit will be high, please keep the interconnection cable away from the copper tube.

3. INSTALLATION/SERVICE TOOLS (Only for R410A product)

CAUTION

New Refrigerant Air Conditioner Installation

THIS AIR CONDITIONER ADOPTS THE NEW HFC REFRIGERANT (R410A) WHICH DOES NOT DESTROY OZONE LAYER. R410A refrigerant is apt to be affected by impurities such as water, oxidizing membrane, and oils because the working pressure of R410A refrigerant is approx. 1.6 times of refrigerant R22. Accompanied with the adoption of the new refrigerant, the refrigeration machine oil has also been changed. Therefore, during installation work, be sure that water, dust, former refrigerant, or refrigeration machine oil does not enter into the new type refrigerant R410A air conditioner circuit.





To prevent mixing of refrigerant or refrigerating machine oil, the sizes of connecting sections of charging port on main unit and installation tools are different from those used for the conventional refrigerant units. Accordingly, special tools are required for the new refrigerant (R410A) units. For connecting pipes, use new and clean piping materials with high pressure fittings made for R410A only, so that water and/or dust does not enter. Moreover, do not use the existing piping because there are some problems with pressure fittings and possible impurities in existing piping.



Changes in the product and components

In air conditioners using R410A, in order to prevent any other refrigerant from being accidentally charged, the service port diameter size of the outdoor unit control valve (3 way valve) has been changed. (1/2 UNF 20 threads per inch)

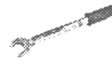
- In order to increase the pressure resisting strength of the refrigerant piping, flare processing diameter and opposing flare nuts sizes have been changed. (for copper pipes with nominal dimensions 1/2 and 5/8)









New tools for R410A

New tools for R410A	Applicable to R22 model		Changes
Gauge manifold	×		As the working pressure is high, it is impossible to measure the working pressure using conventional gauges. In order to prevent any other refrigerant from being charged, the port diameters have been changed.
Charge hose	×		In order to increase pressure resisting strength, hose materials and port sizes have been changed (to 1/2 UNF 20 threads per inch). When purchasing a charge hose, be sure to confirm the port size.
Electronic balance for refrigerant charging	○		As working pressure is high and gasification speed is fast, it is difficult to read the indicated value by means of charging cylinder, as air bubbles occur.
Torque wrench (nominal dia. 1/2, 5/8)	×		The size of opposing flare nuts have been increased. Incidentally, a common wrench is used for nominal diameters 1/4 and 3/8.
Flare tool (clutch type)	○		By increasing the clamp bar's receiving hole size, strength of spring in the tool has been improved.
Gauge for projection adjustment	—		Used when flare is made by using conventional flare tool.

Vacuum pump adapter	○		Connected to conventional vacuum pump. It is necessary to use an adapter to prevent vacuum pump oil from flowing back into the charge hose. The charge hose connecting part has two ports -- one for conventional refrigerant (7/16 UNF 20 threads per inch) and one for R410A. If the vacuum pump oil (mineral) mixes with R410A a sludge may occur and damage the equipment.
Gas leakage detector	×		Exclusive for HFC refrigerant.

- Incidentally, the "refrigerant cylinder" comes with the refrigerant designation (R410A) and protector coating in the U.S's ARI specified rose color (ARI color code: PMS 507).
- Also, the "charge port and packing for refrigerant cylinder" requires 1/2 UNF 20 threads per inch corresponding to the charge hose's port size.

4. ACCESSORIES

No.	Accessories part	Qty.	No.	Accessories part	Qty.
1	Manual package 	1	6	Twin-wire cable(optional) 	1
2	Remote control with batteries 	1	7	Power input cable (Optional) 	1
3	Remote control bracket (optional) 	1	8	Installation carton board (optional) 	1
4	Screws dowels 	6or4	9	Unit support(optional) 	2
5	Outdoor unit drain connector 	1			

5. OPTIONAL ACCESSORIES

6. LOCATION OF THE INDOOR AND OUTDOOR UNITS

This air conditioner has the optional 2-way/3-way air discharging according to installation location. Use sealing material in accessory parts to seal the related air outlets.

Air flow direction (example)

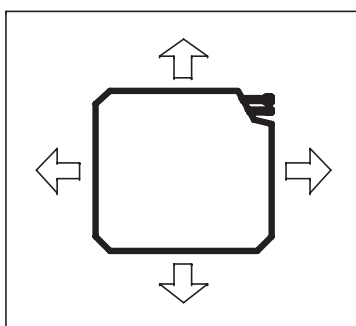

4-way direction (Default)

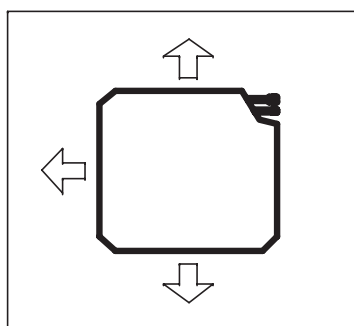

3-way direction

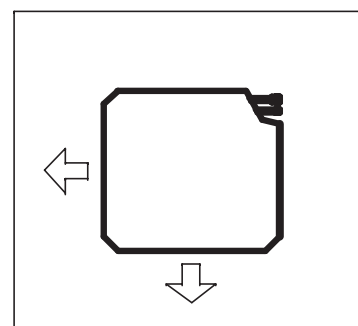

2-way direction

Indoor unit

1. Do not install the cassette in a room where gasses, acids or inflammable products are stored, in order to avoid damage to the aluminum and copper evaporators and the internal plastic parts.
2. Do not install the cassette in a workshop or a kitchen. Oil vapor attracted by the treated air could form deposits on the cassette evaporators and modify their performance or damage the cassette's internal plastic parts.
3. Do not install the cassette in a laundry, or a room where steam is produced.
4. The appliance must be positioned so that the plug is accessible.
5. Installing the cassette will be easier with the use of a fork lift truck. Use the packing base by placing it between the cassette and the truck forks.
6. It is recommended to install the cassette, as far as possible, in the centre of the room, in order to optimize treated air distribution.
7. For the chosen location, check that the distribution grilles can be removed and that there is sufficient space available for maintenance and repairs.

Outdoor unit

1. The location must allow easy servicing and provide good air circulation as shown in fig 4.
2. The unit may be suspended from a wall by a bracket (Optional) or located in a free standing position on the floor (preferably slightly elevated).
3. If the unit is suspended, ensure that the bracket is firmly connected and the wall is strong enough to withstand vibrations.
4. Unit location should not disturb neighbors with noise or exhaust air stream.
5. Place the mounting pads under the unit legs.
6. Refer to figure 4 for allowed installation distances.

When the unit is installed on a wall, install the drain connector hose and drain plug as shown in fig1 and fig2.

Fig.1

1. Bottom of outdoor unit
2. Drain connector

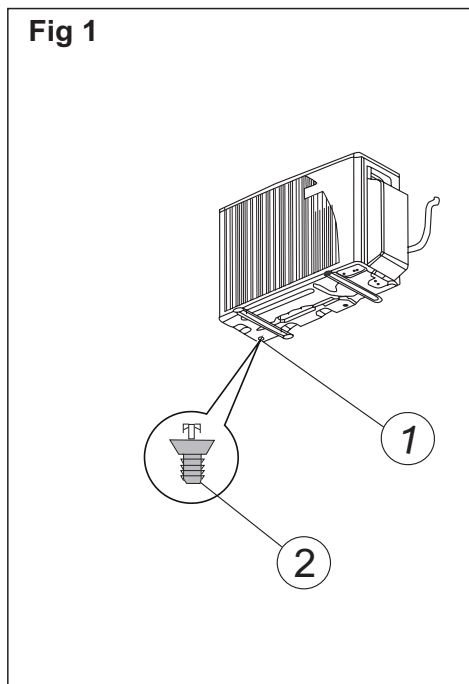
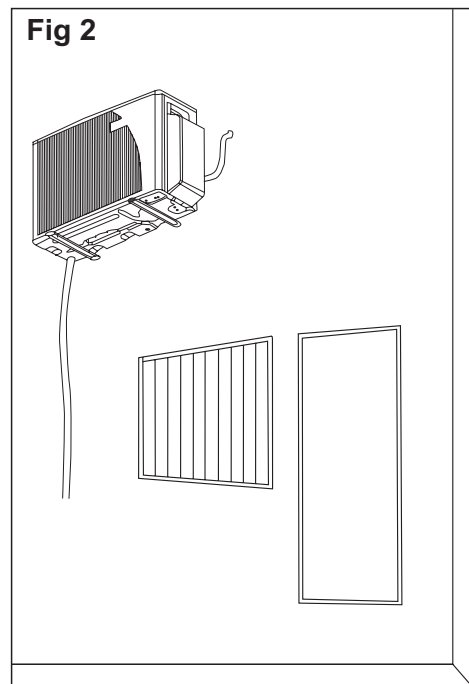
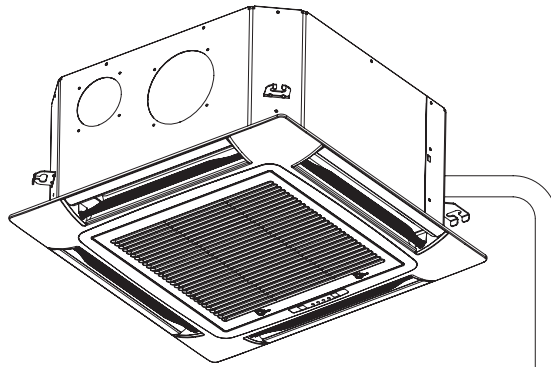
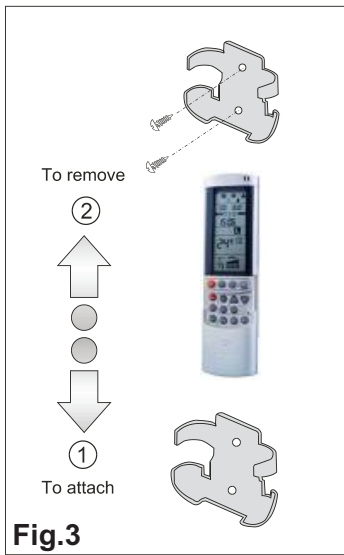

Fig.2

- Drain installation
- Example





MAXIMUM PIPES LENGTH & HEIGHT				
CAPACITY	TUBES OD	LENGTH(A)	HEIGHT(B)	ADDITIONAL CHARGE
09KBTU	1/4''-3/8''	20	15	30
12KBTU	1/4''-1/2''	20	15	30
18KBTU	1/4''-1/2''	20	15	30
24KBTU	3/8''-5/8''	30	15	60
30KBTU	3/8''-5/8''	30	15	60
36KBTU	1/2''-3/4''	50	30	120
42KBTU	1/2''-3/4''	50	30	120
60KBTU	1/2''-3/4''	50	30	120

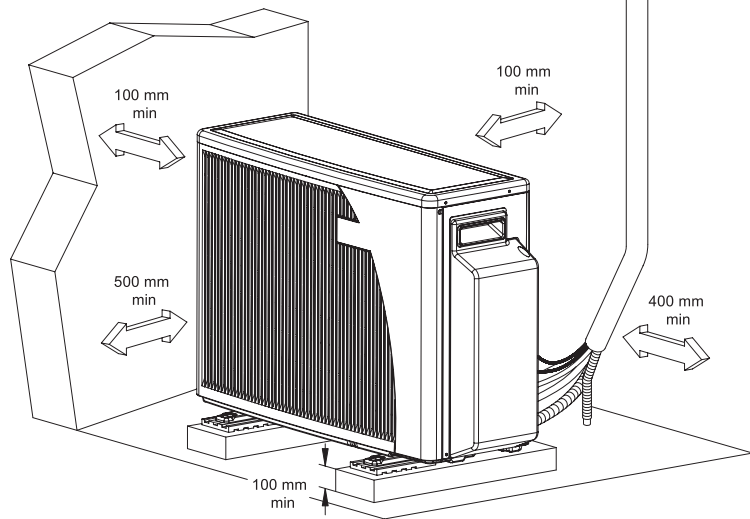

Fig.4

7. INSTALLATION OF THE INDOOR UNIT

Deciding ceiling opening size

1. Gird ceiling installation situation (60x60 standard ceiling):

Because this unit is a mini-cassette, there is no need to make an opening cut on the ceiling, just remove one piece of ceiling panel.

2. Hard ceiling installation situation:

Create the ceiling opening required for installation, below shows the relationship of the ceiling opening to unit and the panel (Fig 5)

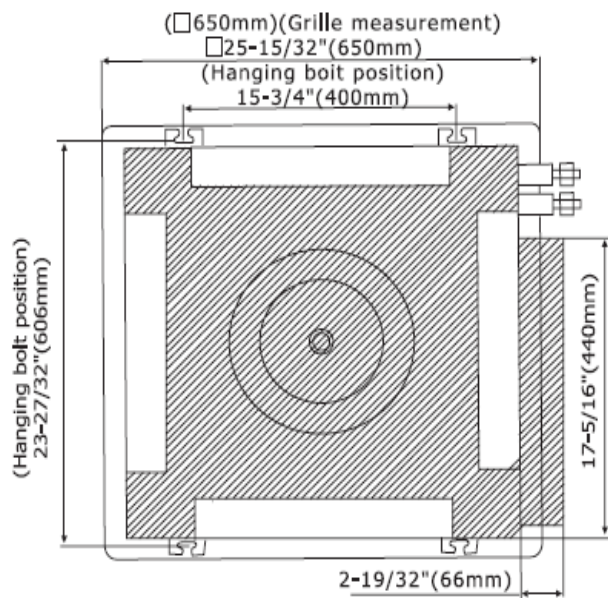

Model
12K
18K

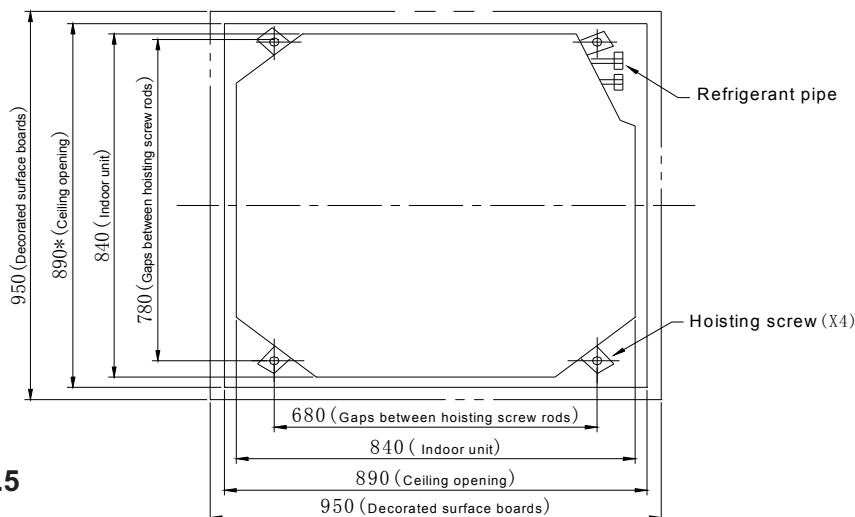

Model
24K
30K
36K
42K
48K

Fig.5

Installing the indoor unit

1. Use installation template (supplied with the panel) when deciding the suspension bolt position. Fig.7 and table 1 show the dimensions relationship.

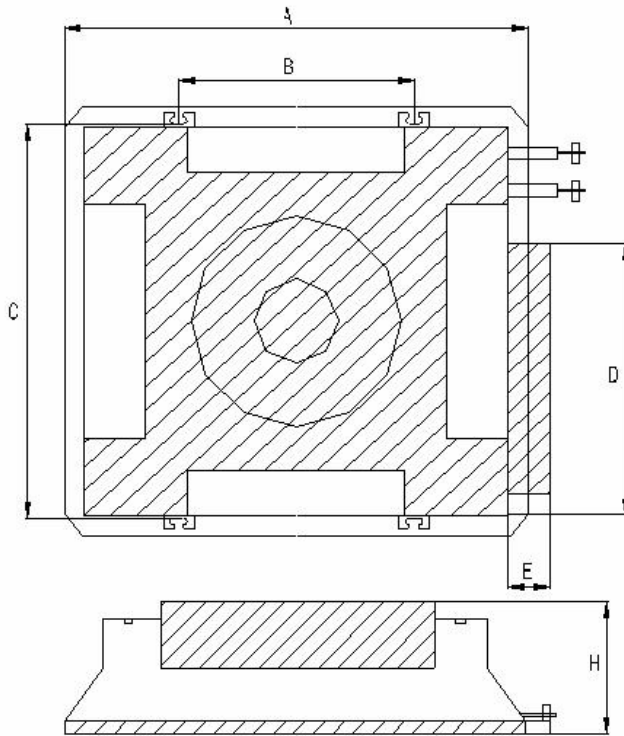

Fig.7

Table 1

Model	H	A	B	C	D	E
12K	245	650	400	606	440	66
18K						
24K	275	950	680	840	720	76
30K						
36K	345	950	680	840	720	76
42#, K						

2. Tubing and wiring must be prepared beforehand inside the ceiling when suspending the unit.

3. The length of suspension bolts must be appropriate for a distance between the bottom of the bolt and the bottom of the unit of more than 15mm as shown in Fig.8

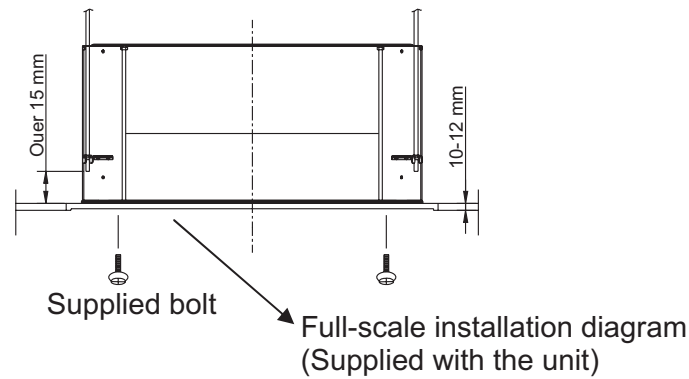

Fig.8

4. In order to prevent a possible looseness, it is recommended to use 3 hexagonal nuts (Prepared on site) and 2 washers (accessory) for each suspension bolt. Pay attention that 2 nuts will be used in the lower side.(Fig.9)
5. Adjust the distance between the unit and the ceiling bottom to 10~12mm. Tighten all the nuts on the suspending bolts.(Fig.9)

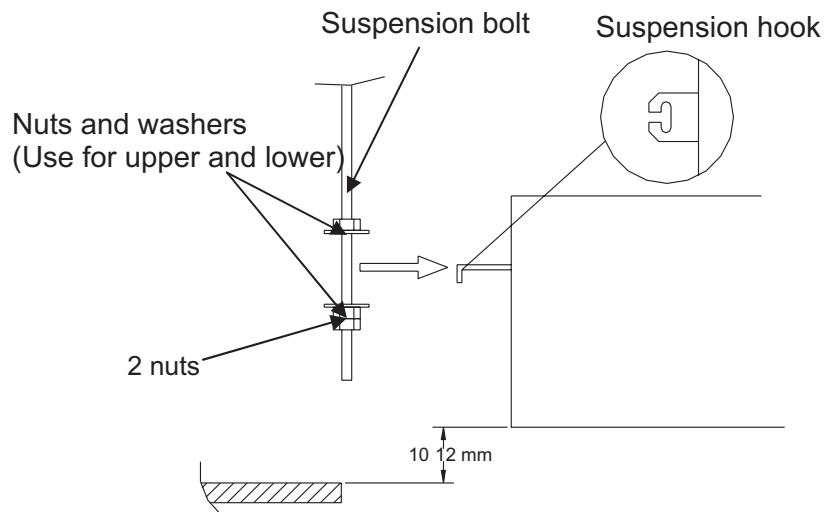

Fig.9

Duct installation

1. Side openings are provided for installing separate ducts for outside air intake and treated air distribution to an adjacent room.
2. Use a punch to remove the knock-down openings on the casing. Use a knife to make the suitable opening on the polystyrene behind the casing.

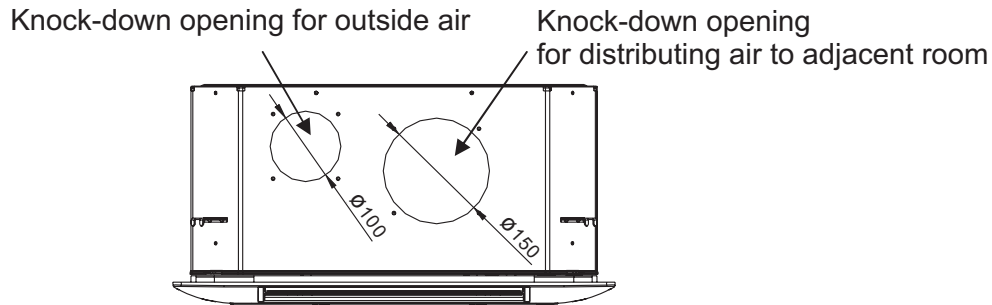

Fig.10

TAKE CARE not to damage the heat exchanger coil located behind the openings.

3. Plug the gaps between the ducts and the opening edge with anti-condensation insulation.
4. Use material which can withstand a continuous operating temperature of 60°C . The ducts can be of the flexible type with a spring core or of corrugated aluminum, covered inside with an insulating material (12 to 25 mm thick glass fiber).
5. When the installation is finished, all the surfaces of the non-insulated ducts must be covered with anti-condensation insulation material (6mm thick expanded polystyrene or expanded neoprene). Fireproofing classification: M1.

IF THE ABOVE INSTRUCTIONS ARE NOT FOLLOWED, CONDENSATE FLOWS WILL BUILD UP.

6. Distributing air to an adjacent room requires the corresponding panel air outlets to be sealed by using the sealing material (Accessory)
7. A decoration grille must be fitted in the partition between the air conditioned room (where the cassette is installed) and the adjacent room.

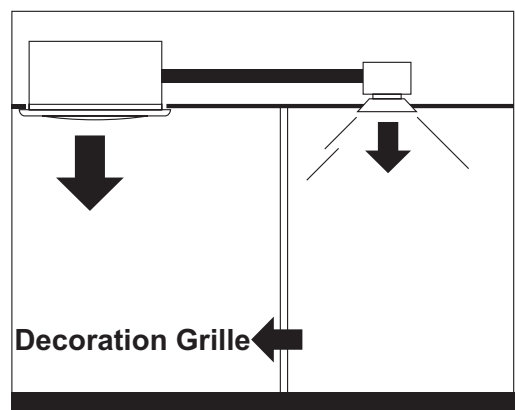

Fig.11

8. CONDENSATE HOSE CONNECTION

Drain hose connection

1. Use standard hard PVC pipe (19mm) for the drain pipe.
2. Use the drain hose (Accessory) to change the direction.
3. Insert the drain hose until it connects the drain port very well, and then secure it tightly with the hose clamp(Accessory)(Fig.12)
4. After checking the drainage, wrap the drain hose with the insulation and clamps (Accessory). (Fig.12)

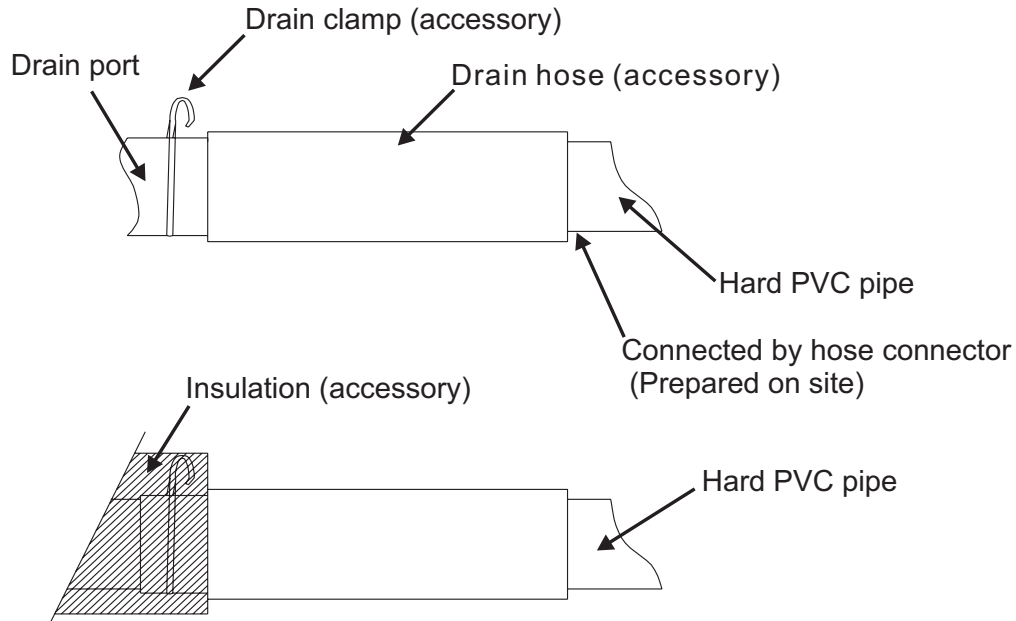

Fig.12

Caution!

1. Do not raise the drain pipe higher than 1m, or else there will be water leak risk.(Fig.13)
2. Make sure the drain pipe has a downward gradient (no less than 1/100) and there are no water traps (Fig.13).
3. To hold the drain pipe, space bracket every 1 to 1.5m.(Fig.13)

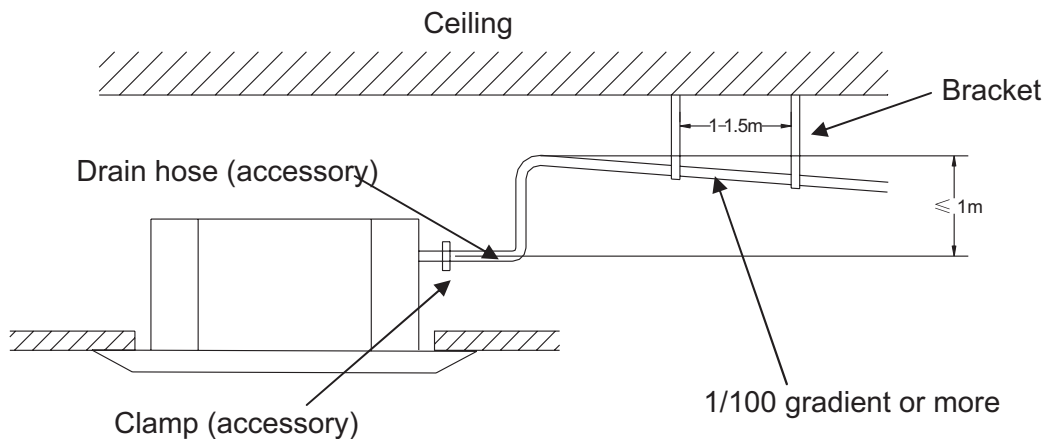

Fig.13

Check the drainage

1. After wiring and drain piping are completed, check the drainage according to the following procedure. If necessary, prepare a bucket and cloth to catch and wipe up the water spilled out.
2. Connect the AC 220V~240V power to the terminal blocks (L, N terminals) inside the electrical box.
3. Slowly inject about 1,000 cc of water into the drain pan.(Fig.14)
4. Operate the unit in cooling mode. Check the drainage through the transparent drain port to see if any drain leakage happens.
5. When the check is finished, do not forget to cut off the power input.

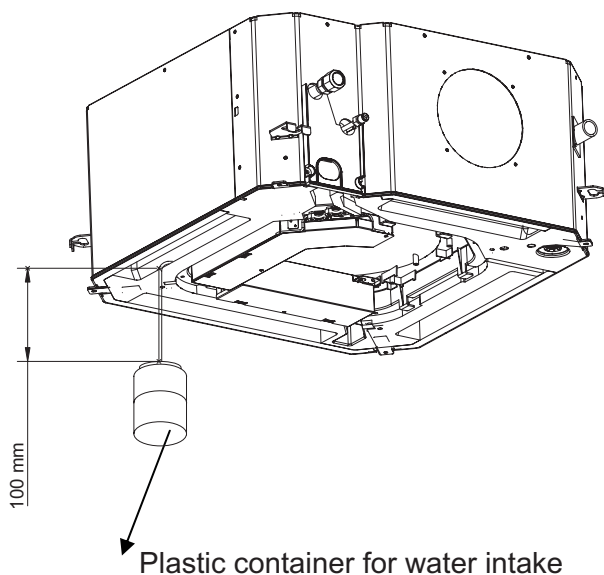

Fig.14

Caution!

During this operation, the fan will start working. So pay attention to the rotating fan.

Finish the drainage work.

After checking the drainage, make sure that heat insulation is wrapped around the indoor drain pipe to avoid any dew condensation. (The material should have M1 fireproofing classification)

9. ELECTRICAL CONNECTION BETWEEN INDOOR AND OUTDOOR UNIT

Electrical requirements

Electrical wiring and connections should be made by qualified electricians and in accordance with local electrical codes and regulation. The air conditioner units must be grounded.

The air conditioner unit must be connected to an adequate power outlet from a separate branch circuit protected by a time delay circuit breaker, as specified on unit's nameplate.

Voltage should not vary beyond $\pm 10\%$ of the rated voltage.

1. To connect the indoor unit to the outdoor unit uses the following electrical cables(Page 16).
2. Prepare the cable ends for the power input and for the cables between outdoor and indoor units as shown in figure 15a and 15b respectively.
3. Connect the cable ends to the terminals of the indoor and outdoor units, as shown in fig 16.
4. Secure the multiple wire power cable with the cable clamps.

Notes: The wire color code can be selected by the installer.

• Power input cable

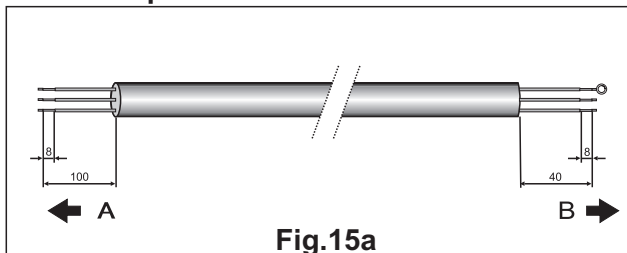

• Cable between indoor and outdoor units

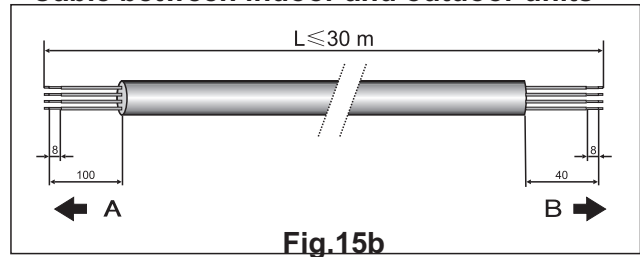
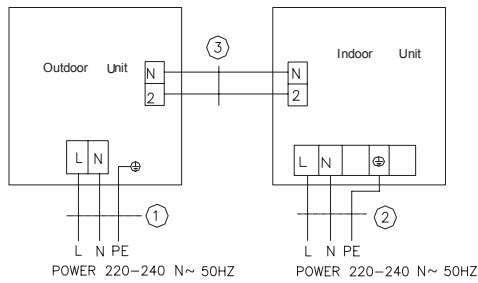

Fig.15 A. OUTDOOR B. INDOOR

Wiring procedures

9K/12K/18K/24K (1 PH)



- 1. Power Cord 3× 2.5 mm²
- 2. Power Cord 3× 1.5 mm²
- 3. Communication Cords 2× 0.75 mm²

30K/36K (1 PH)

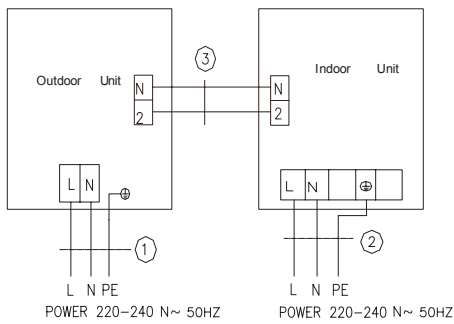

- 1. Power Cord 3× 6 mm²
- 2. Power Cord 3× 1.5 mm²
- 3. Communication Cords 2× 0.75 mm²

36K/42K/48K (3 PH)

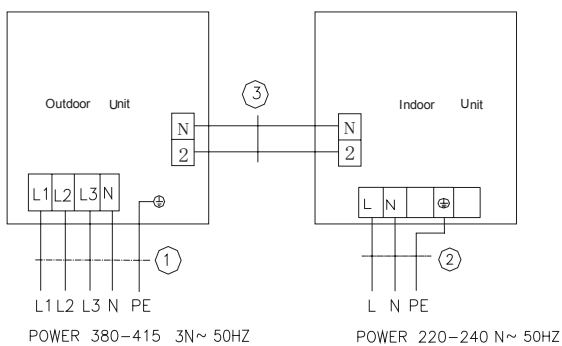

- 1. Power Cord 5× 4 mm²
- 2. Power Cord 3× 1.5 mm²
- 3. Communication Cords 2× 0.75 mm²

10. REFRIGERANT TUBING

Connect the indoor to the outdoor unit

The indoor unit contains a small quantity of nitrogen. Do not unscrew the nuts from the unit is supplied with sufficient refrigerant charge (R410A). Refer to outdoor unit nameplate.

To prevent crushing, bend tubes using a bending tool.

NOTE: Use R410A refrigerant type copper tubing only.

1. Open the valve cover.
2. Use tubing diameter that corresponds to the tubing diameter of the indoor and outdoor units. Note that the liquid and suction tubes have different diameters. (See tube size, torque tightening table.)
3. Place flare nuts on tube ends before preparing them with a flaring tool. Use the flare nuts that are mounted on the supplied outdoor and indoor units.
4. Connect the all ends of the tubing to the indoor and outdoor units. Notice the sign. All ends should correspond one by one.
5. Insulate each tube separately, and their unions, with at least 6 mm thick of insulation. Wrap the refrigerant tubing, drain hose and electric cables together with a vinyl tape (UV protected).

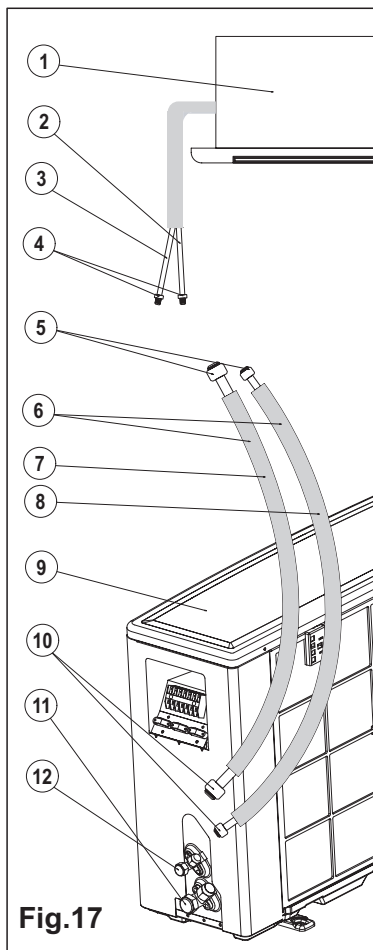

Fig.17

Tightening torques of unions and valve caps:

Caution!

When unscrewing the valve caps, do not stand in front of them or the spindles at any time, as the system is under pressure.

Fig.17

1. Indoor unit
2. Liquid tube (small dia.)
3. Suction tube (large dia.)
4. Plugs
5. Flare nuts
6. Tubing between units
7. Suction tube
8. Liquid tube
9. Outdoor unit
10. Flare nuts
11. Suction valve (large)
12. Liquid valve (small)

TUBE SIZE	TORQUE
Liquid line 1/4"	15-20 N.M.
Suction line 3/8"	30-35 N.M
Suction line 1/2"	50-54N.M.
Suction line 5/8"	75-78N.M.

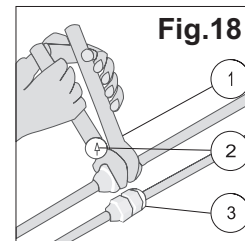

Fig.18

1. Wrench
2. Torque wrench
3. Union

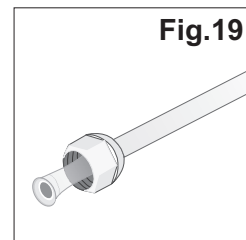

Fig.19

Fig.19
To prevent refrigerant leakage, coat the flared surface with refrigeration oil

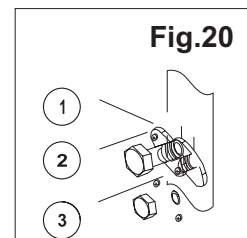

Fig.20

1. Suction valve
2. Service port
3. Liquid valve
4. Union

Do the vacuum of the refrigeration tubes and the indoor unit

After connecting the unions of the indoor and outdoor units, purge the air from the tubes and indoor unit as follows:

1. Connect the charging hoses with a push pin to the low side of the charging set and the service port of the suction valve. Be sure to connect the end of the charging hose with the push pin to the service port.
2. Connect the center hose of the charging set to a vacuum pump.
3. Turn on the power switch of the vacuum pump, turn off the high side switch and make sure that the needle in the gauge moves from 0 MPa (0cm Hg) to -0.1MPa (-76cm Hg). Let the pump run for fifteen minutes.
4. Close the valve of the low side of the charging set and turn off the vacuum pump. Note that the needle in the gauge should not move after approximately five minutes.
5. Not any problem for five minutes, turn on the power switch of the vacuum pump and open the valve of the low side of the charging set.
6. Disconnect the charging hose from the vacuum pump and from the service ports of the suction valve.
7. Tighten the service port caps of suction valve.
8. Redo 1 to 7 for other indoor units.
9. Remove the valve caps from all valves, and open them using a hexagonal Allen wrench.
10. Remount valve caps from all of the valves.
11. Check for gas leaks from all the connecting position.

Test with electronic leak detector or with a sponge immersed with soapy water for bubbles.

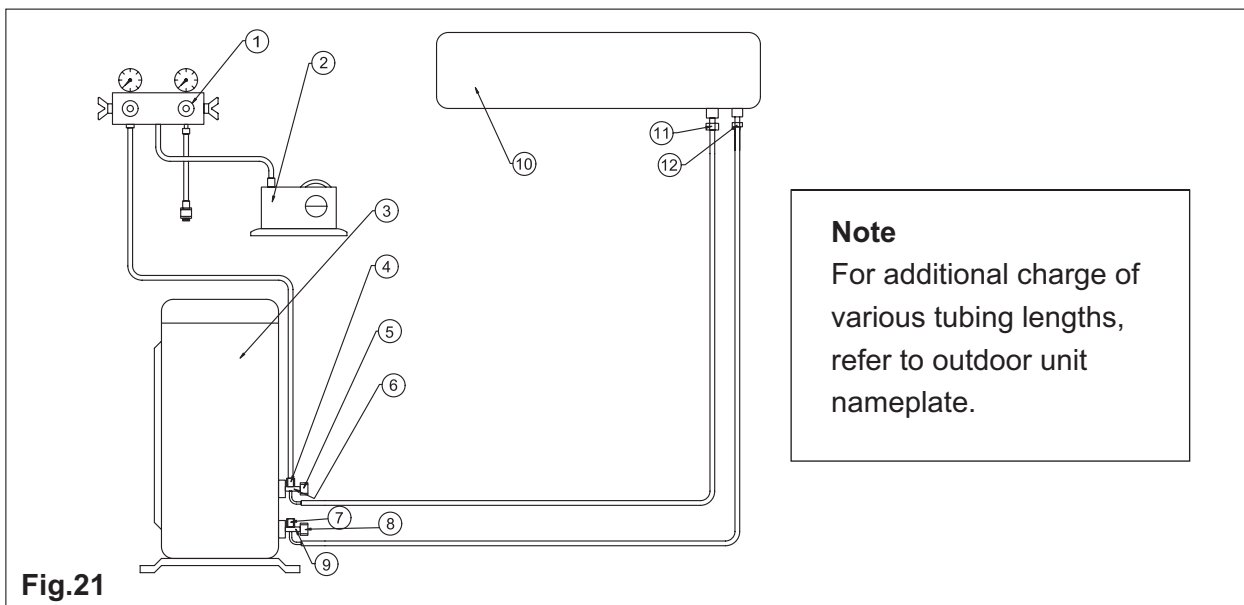

Note
For additional charge of various tubing lengths, refer to outdoor unit nameplate.

- | | | |
|-----------------|-------------------|------------------------------|
| 1. Charging set | 5. Cap | 9. Liquid valve |
| 2. Vacuum pump | 6. Suction valve | 10. Indoor unit |
| 3. Outdoor unit | 7. Service port * | 11. Suction flare connection |
| 4. Service port | 8. Cap | 12. Liquid flare connection |

* In some models only

11. PANEL INSTALLING

Removing the grille:

1. To open the grille, rotate the grille lock counterclockwise from horizontal position to vertical position.(fig.22)

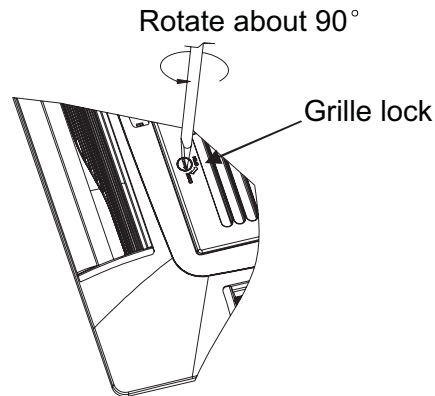

Fig.22

2. With the grille fully opened, remove the grille along the direction shown in Fig.23.

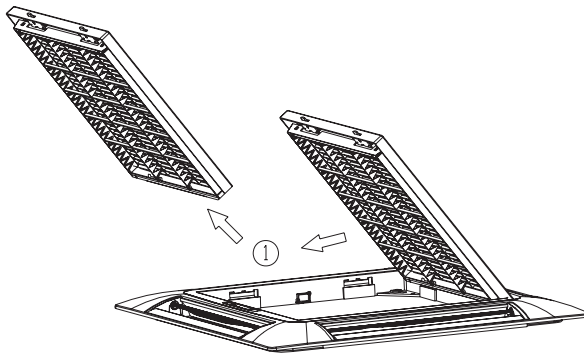

Fig.23

Temporary installation of the panel

1. Install two bolts (Accessory) onto the main unit (the corner of refrigerant tubing side and the opposite corner).The detail is shown in Fig.24. Pay attention that leave 15-20mm bolt unscrewed so as to hang the panel easily

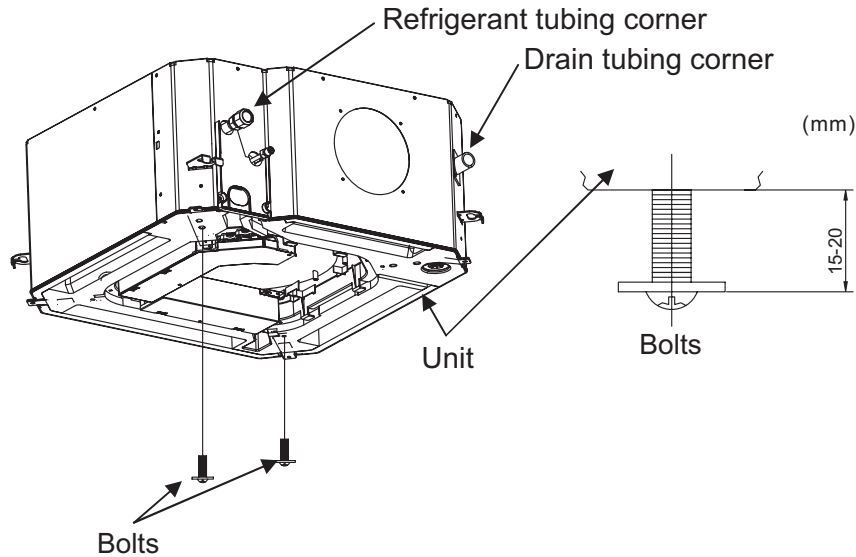

Fig.24

2. Attach the panel to the main unit, twist the panel to make sure that the two bolts mentioned above are screwed into the cavity on the panel. Thus the panel can keep balance with the two bolts.
3. Pay attention that the TUBE and DRAIN marks on the ceiling panel are in the correct positions on the unit.
4. Tighten all bolts (the previously two installed bolts as well as the two remaining bolts.) to secure the panel.
5. Pay attention that there should be no gaps between the unit and the ceiling panel, or between the ceiling panel and the ceiling.

Wiring of panel

1. Connect the 12Pin cable connector from the ceiling panel to the relative connector which comes out of the control box. Fig.25

Caution!

If this connector is not connected, the display will not work. Make sure the cable is connected securely.

2. Connect the 5Pin cable connector from the ceiling panel to the relative connector comes out of the control box.(Fig.25)

Caution!

If this connector is not connected, the louver will not work. Make sure the cable is connected securely.

12. FINAL TASKS

1. Check all valve caps and ensure that they had been tightened properly. Close the valve cover.
2. Fill gaps on the wall between hole sides and tubing with sealer.
3. Attach wiring and tubing to the wall with clamps where necessary.
4. Operate the unit for no less than 5 minutes at heating or cooling mode.
5. Explain filter removal, cleaning and installation.
6. Operate the air conditioner together with the customer and explain all functions.
7. Give the operating and installation manuals to the customer.